

UM10878

PN7120 NFC controller SBC kit user manual

Rev. 1.5 — 9 February 2021

318515

User manual
COMPANY PUBLIC

Document information

Information	Content
Keywords	OM5577, PN7120, demo kit, Raspberry Pi, BeagleBone
Abstract	This document is the user manual of the PN7120 NFC controller SBC kit.



1 Revision history

Revision history

Rev	Date	Description
1.5	20210209	Removed Windows IoT support
1.4	20170104	Added CE certification details
1.3	20160707	Added demo kit performance details
1.2	20160503	FCC statement updated
1.1	20151007	<ul style="list-style-type: none">• FCC statement added• Note about useless of some components on the schematics added• Section Legal information updated
1.0	20150519	First release

2 Introduction

The present document describes the OM5577/PN7120S demonstration kit, a flexible and easy-to-use Single Board Computer (SBC) Kit for the PN7120 NFC controller.

It contains a PN7120 NFC controller board, a Raspberry Pi interface board, a BeagleBone interface board, as well as an NFC Forum Type 2 Tag in a form of a MIFARE Ultralight card. It enables the development of an NFC solution based on PN7120 in a Linux or Android environment.

In this document, the term „MIFARE Ultralight card“ refers to a MIFARE Ultralight IC-based contactless card.

PN7120 is a full NFC controller solution with integrated firmware and NCI interface designed for contactless communication at 13.56 MHz.

This document presents first an overview of the kit.

Then, it gives printed circuit boards details.

Finally, it provides information for reuse of the kit in different environments.

This kit is registered as FCC certified module (FCC ID: OWROM5577-PN7120S).

3 Overview

3.1 Kit description

OM5577/PN7120S kit is a high performance fully NFC-compliant expansion board for both Raspberry Pi (refer to [1] for more details) and BeagleBone (refer to [2] for more details). It meets compliance with reader mode, P2P mode and Card emulation mode standards. The board features an integrated high performance RF antenna to insure high interoperability level with NFC devices.

3.2 Kit content

The kit is composed of 3 printed circuit boards and a MIFARE Ultralight EV1 card.



Figure 1. PN7120NFC controller SBC kit content

3.2.1 PN7120 NFC controller board

The PN7120 NFC controller board is the main board of the demonstration kit. It embeds the PN7120 and all related circuitry.

It also includes an onboard RF antenna with related matching circuitry.

This main board has to be used in association with one of the 2 interface boards depending on the target user environment (Raspberry Pi or BeagleBone).

For this purpose, it integrates dedicated connectors allowing boards assembly.



3.2.2 BeagleBone interface board

The BeagleBone interface board offers support for connection to BeagleBone board (refer to [\[2\]](#) for more details).

As such it integrates the connectors allowing the PN7120 NFC controller board to be plugged on it, as well as connectors to be assembled on top of the BeagleBone board.



Figure 3. BeagleBone interface board

3.2.3 Raspberry Pi interface board

The Raspberry Pi interface board offers support for connection to Raspberry Pi board (refer to [\[1\]](#) for more details).

As such it integrates the connectors allowing the PN7120 NFC controller board to be plugged on it, as well as connector to be assembled on top of the Raspberry Pi board.

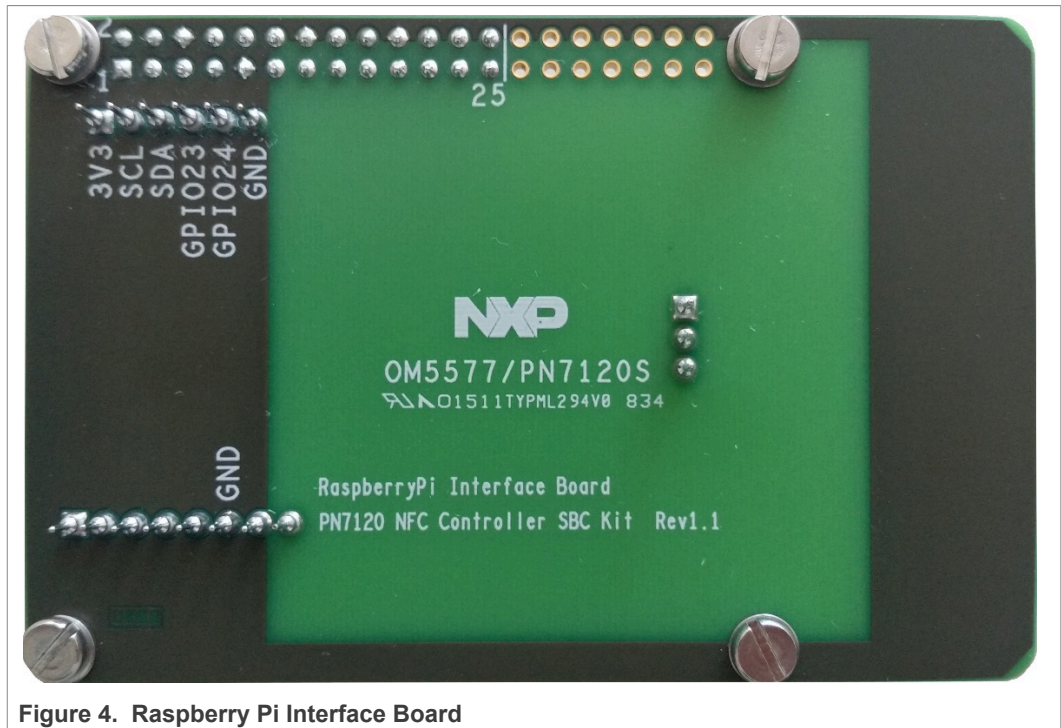

Figure 4. Raspberry Pi Interface Board

3.2.4 MIFARE Ultralight EV1 card

OM5577/PN7120S kit includes a MIFARE Ultralight EV1 card allowing to demonstrate NFC reader capabilities of PN7120 NFC controller.

MIFARE Ultralight EV1 is the next generation of paper ticketing smart card IC for limited-use applications. It offers solution developers and operators the maximum flexibility for their ticketing schemes and additional security options.

For the current purpose of PN7120 NFC Controller demonstration, the card has been set as NFC Forum Type 2 Tag, and pre-configured with NDEF URI type message "<https://www.nxp.com/products/rfid-nfc/nfc-hf/nfc-readers/development-kits-for-pn7120-plugin-play-nfc-controller:OM5577>".



Figure 5. MIFARE Ultralight EV1 card

4.1.2 Layout

4.1.2.1 Components layers

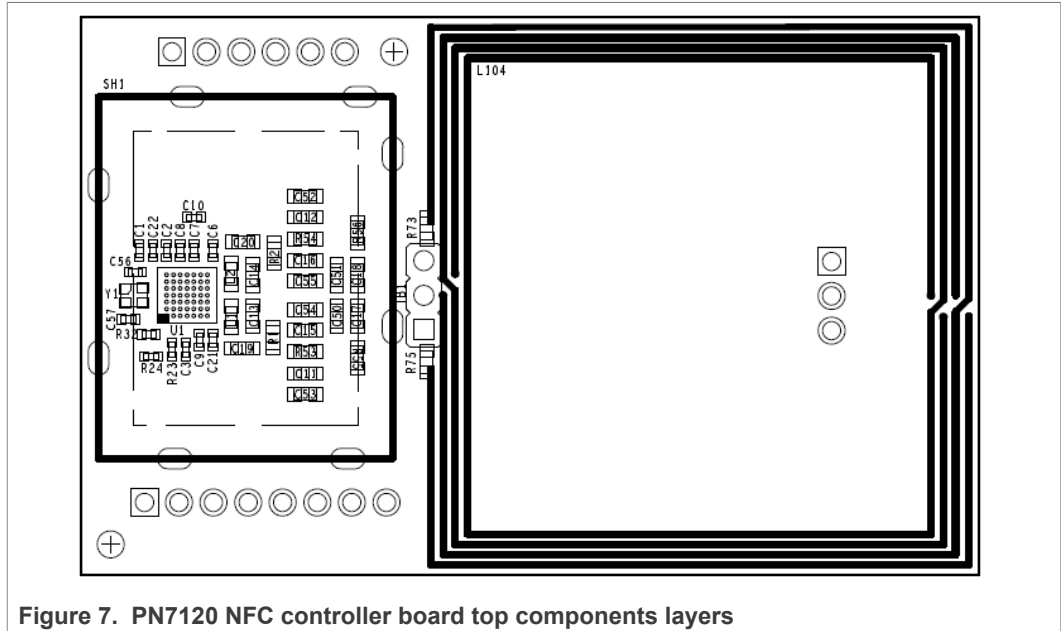

Figure 7. PN7120 NFC controller board top components layers

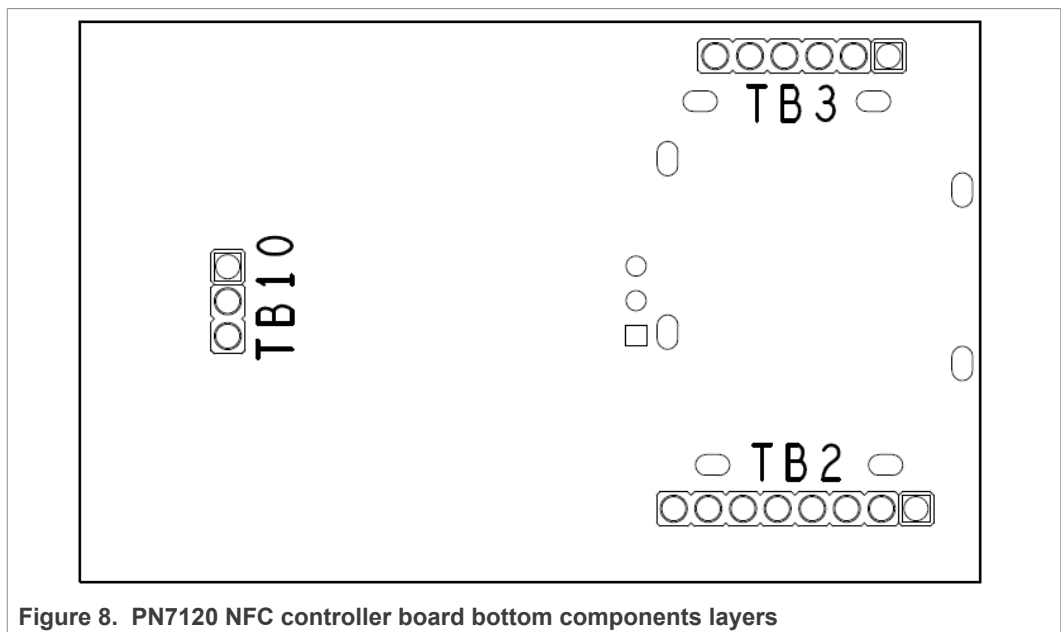

Figure 8. PN7120 NFC controller board bottom components layers

4.1.2.2 Layer 1

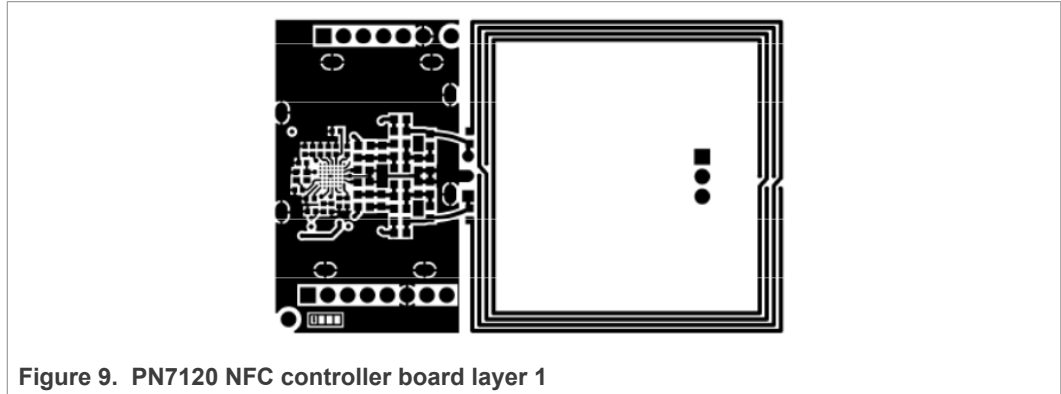

Figure 9. PN7120 NFC controller board layer 1

4.1.2.3 Layer 2

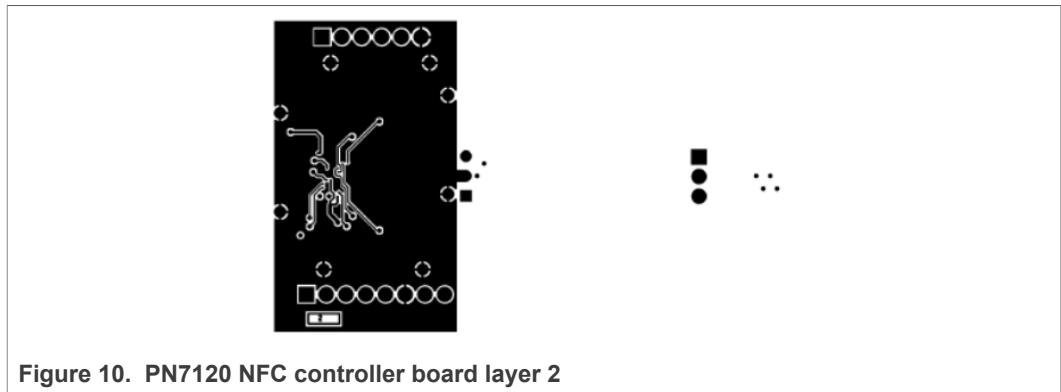

Figure 10. PN7120 NFC controller board layer 2

4.1.2.4 Top silkscreen layer

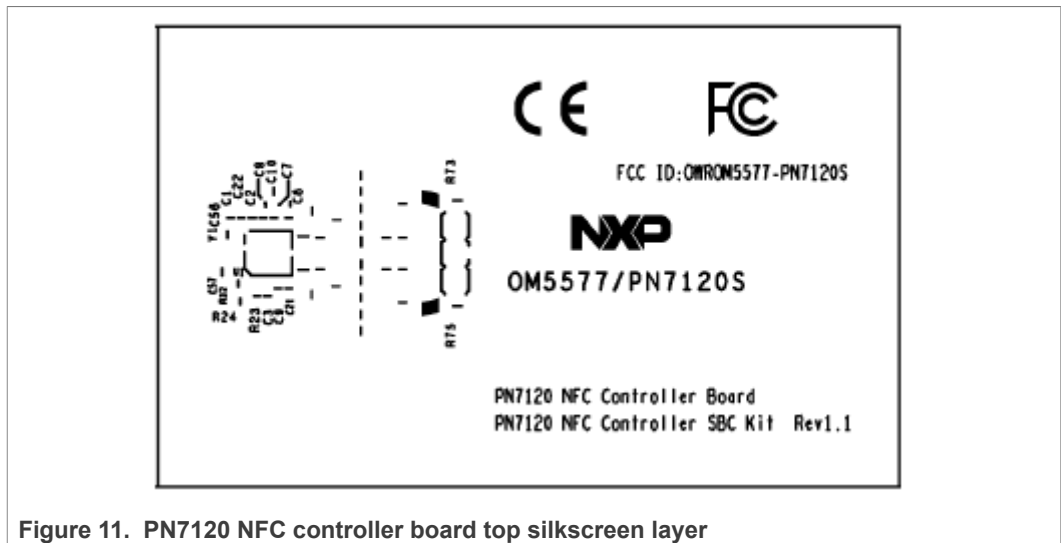

Figure 11. PN7120 NFC controller board top silkscreen layer

4.2 BeagleBone interface board

4.2.1 Schematics

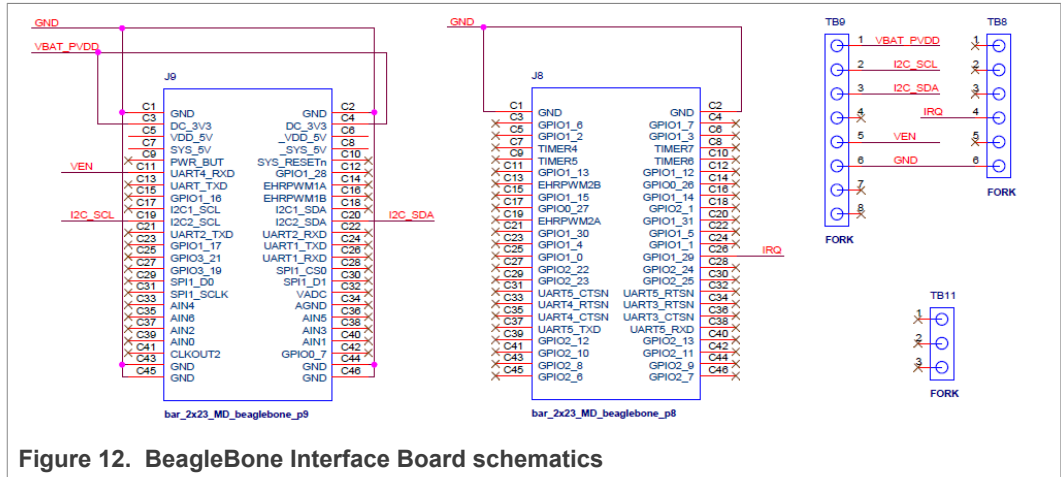

Figure 12. BeagleBone Interface Board schematics

4.2.2 Layout

4.2.2.1 Components layers

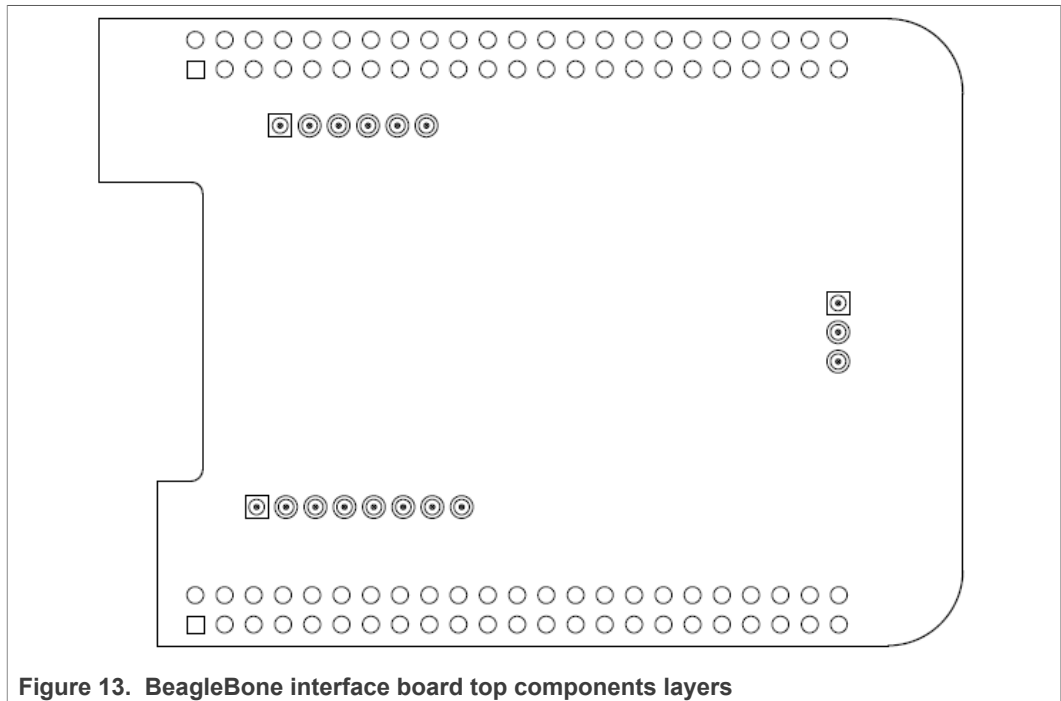
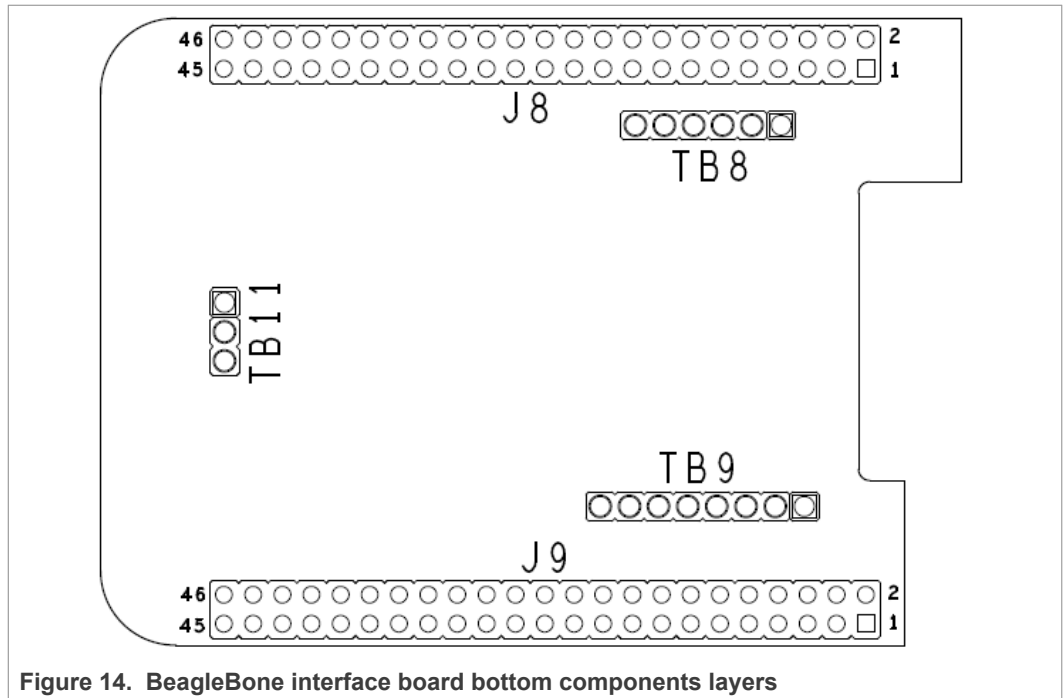
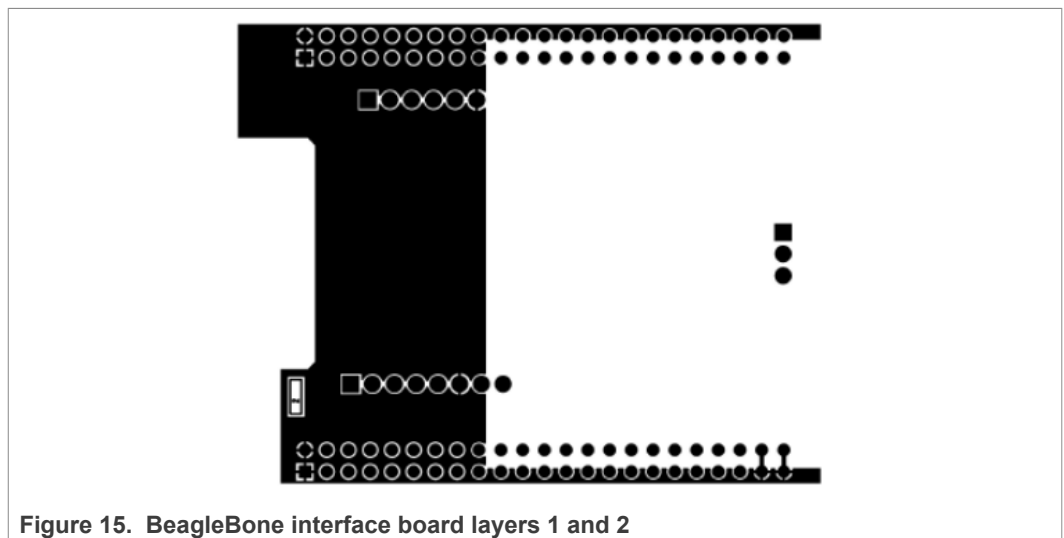

Figure 13. BeagleBone interface board top components layers



4.2.2.2 Layers 1 and 2



4.2.2.3 Layer 3

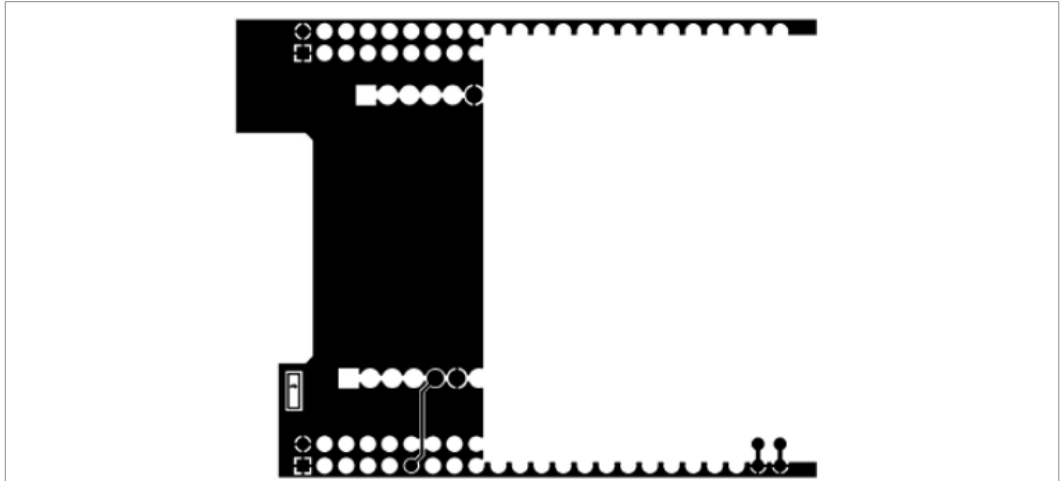

Figure 16. BeagleBone interface board layer 3

4.2.2.4 Layer 4

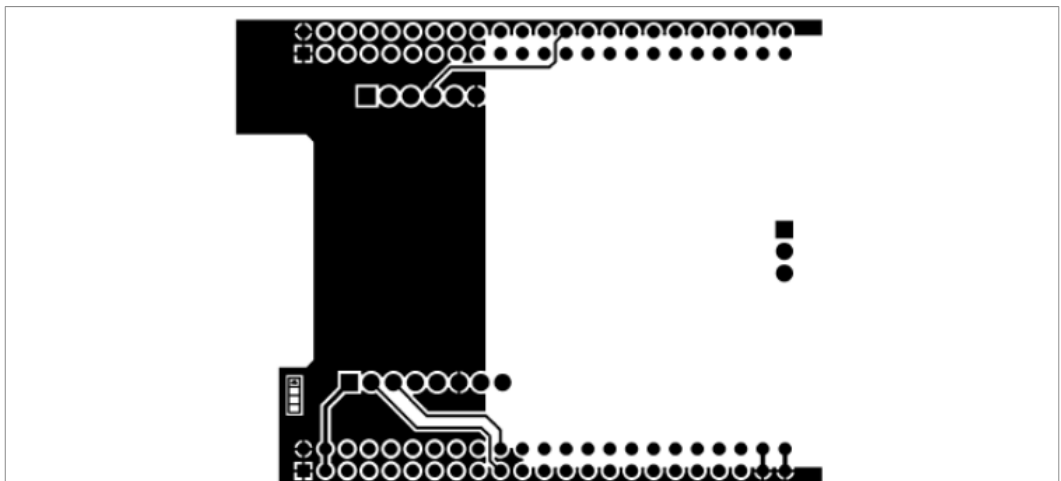

Figure 17. BeagleBone interface board layer 4

4.2.2.5 Top silkscreen layer

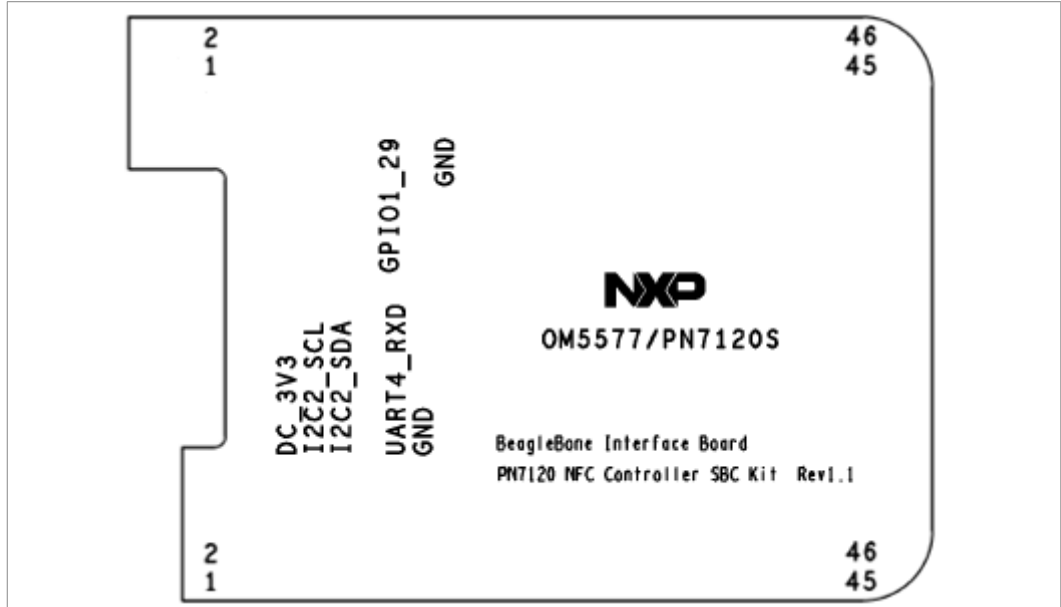

Figure 18. BeagleBone interface board top silkscreen layer

4.3 Raspberry Pi interface board

4.3.1 Schematics

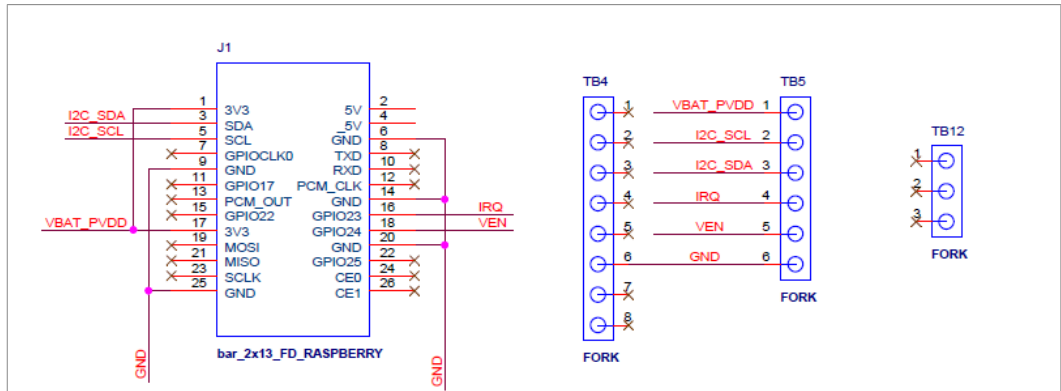

Figure 19. Raspberry Pi interface board schematics

4.3.2 Layout

4.3.2.1 Components layers

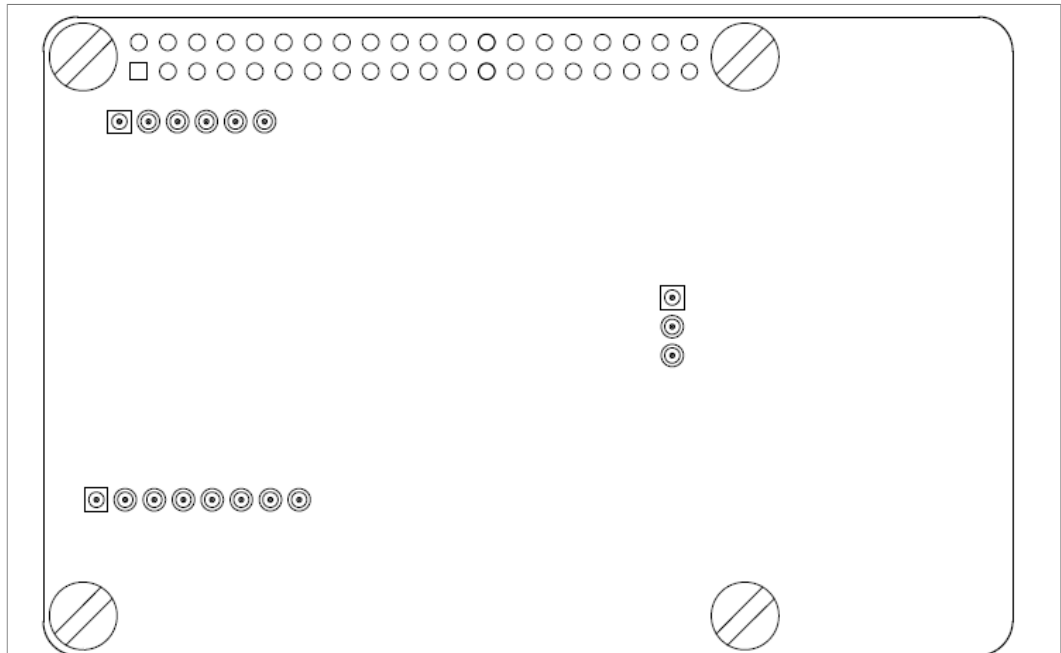

Figure 20. Raspberry Pi interface board top components layers

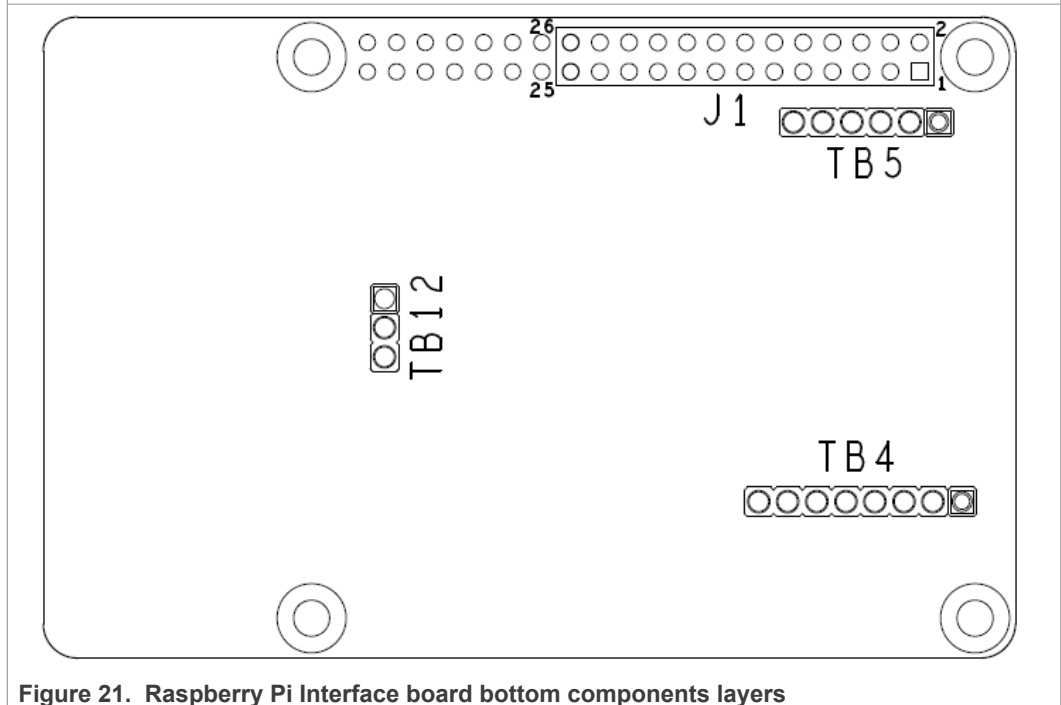

Figure 21. Raspberry Pi Interface board bottom components layers

4.3.2.2 Layers 1 and 2

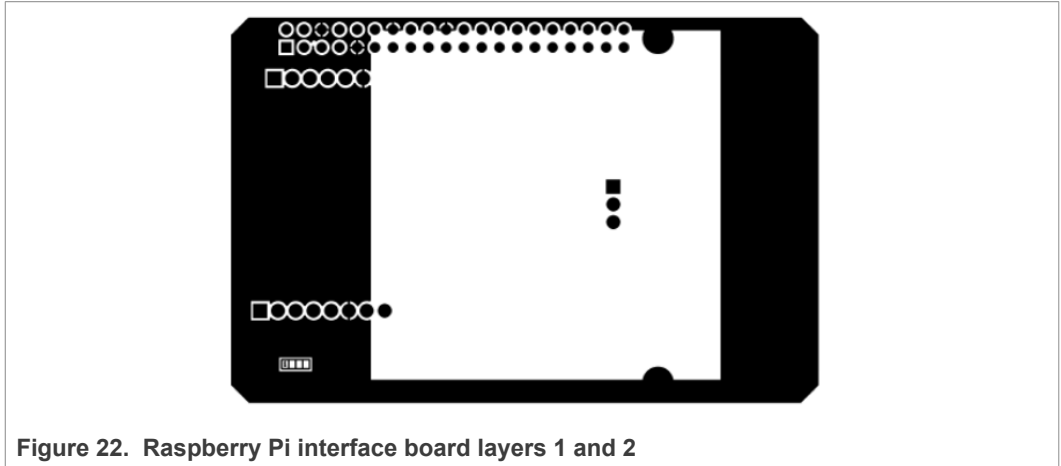

Figure 22. Raspberry Pi interface board layers 1 and 2

4.3.2.3 Layer 3

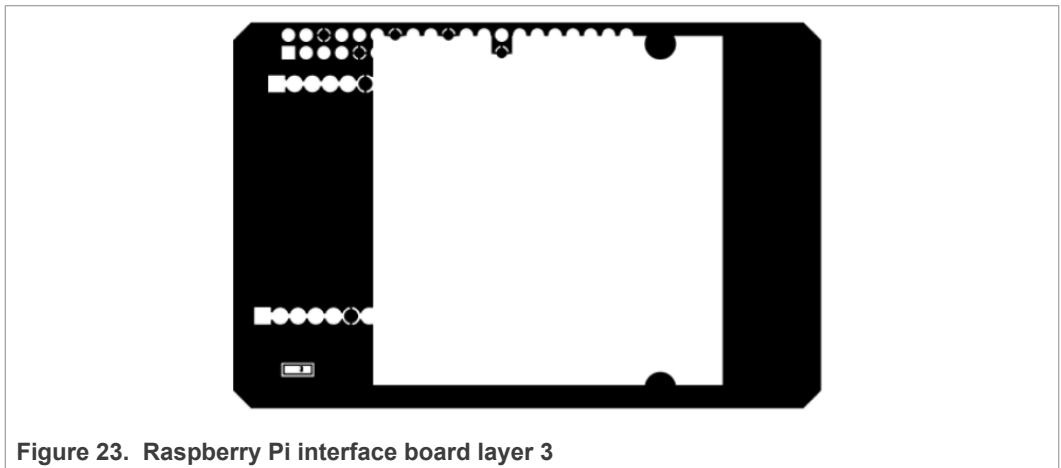

Figure 23. Raspberry Pi interface board layer 3

4.3.2.4 Layer 4

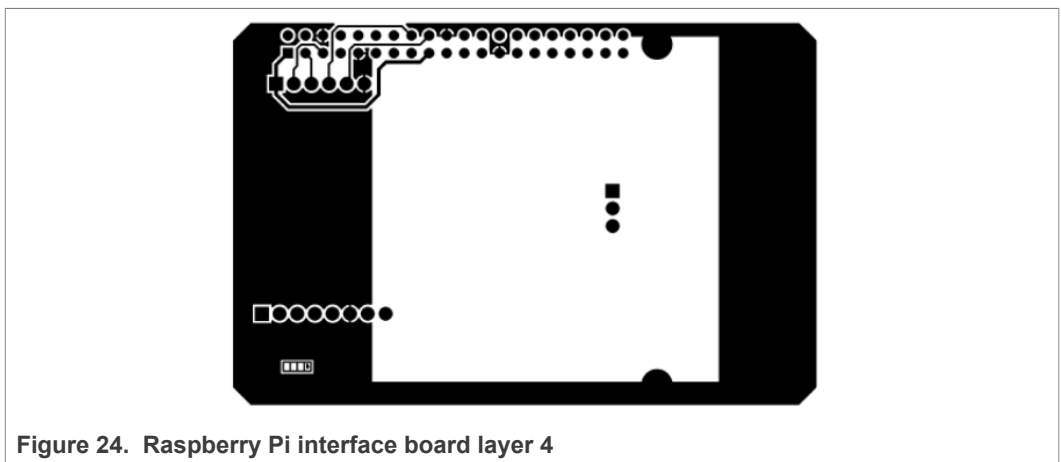

Figure 24. Raspberry Pi interface board layer 4

4.3.2.5 Top silkscreen layer

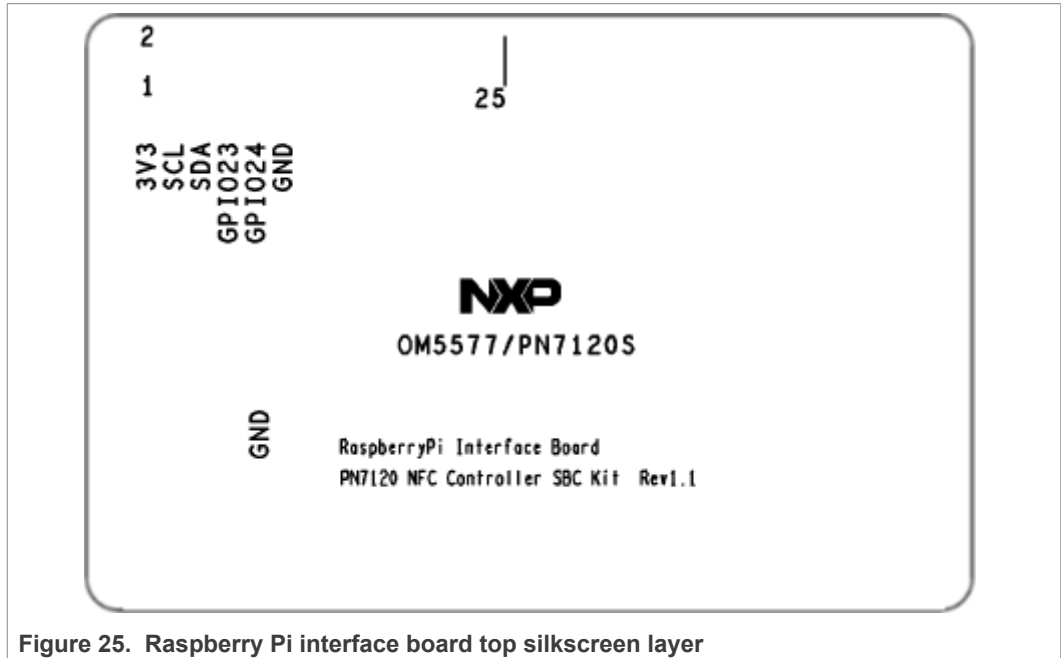

Figure 25. Raspberry Pi interface board top silkscreen layer

5 PN7120 NFC controller board performances

Following RF performance results are obtained running the demo kit:

Table 1. Power transfer (Poll mode)

Measured with EMVCo reference PICC

@ 0 cm	@ 1 cm	@ 2 cm	@ 3 cm
7.6 V	6.7 V	4.3 V	1.2 V

Table 2. Reader/Writer mode performance

Card type	Communication distance (mm)
ISO 15693 UPM RaceTrack	120
NFC Sample Card (NTAG216 – ID1)	80
NFC Sticker (NTAG216 – 40x40)	68
Topaz (35mm Round)	55
Type B (ID1)	45
FeliCa (ID1)	36

Table 3. Peer to Peer mode performances

Vs Samsung Galaxy S7 phone

Communication distance	
moving phone from far to close	moving phone from close to far
50	65

Table 4. Card mode performance

Vs NXP Pegoda Reader

Communication distance (mm)
180

6 Additional information

6.1 Using different antenna

The OM5577/PN7120S kit provides a flexible way of connecting an external RF antenna to be used in place of the onboard one.

On the PN7120 NFC controller board, the dedicated 3 pins connector referenced as TB1 allows connecting your own antenna.

In this case, the onboard antenna must be first disconnected, removing resistors R75 and R73.

Obviously matching circuitry must be adapted as described in related document “AN11564 - PN7120 antenna and tuning design guide” (can be downloaded from PN7120 product web page [\[3\]](#)).



Figure 26. PN7120 NFC controller board RF antenna components

Table 5. PN7120 NFC controller board TB1 connector pinout

TB1	PN7120 signal
#1	ANTENNA 1
#2	GND
#3	ANTENNA 2

6.2 Using in another system

The OM5577/PN7120S demonstration kit can be reuse in another system than Raspberry Pi or BeagleBone.

Indeed, the PN7120 NFC controller board provides all required signal on TB2 and TB3 (signals are duplicated on both connectors) connectors to interface boards.

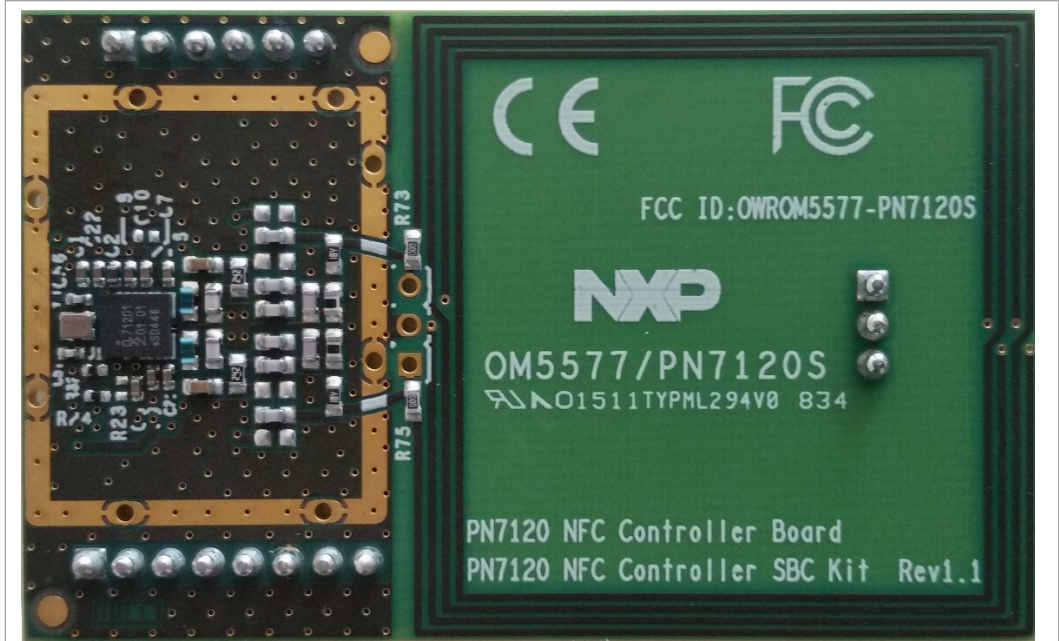

Figure 27. PN7120 NFC controller board interface connectors

Table 6. PN7120 NFC controller board TB2 connector pinout

TB2	PN7120 signal
#1	VBAT/VDD(PAD): 3.3 V supply voltage
#2	I2CSCL: I2C-bus serial clock input
#3	I2CSDA: I2C-bus serial data
#4	IRQ: interrupt request output
#5	VEN: reset pin
#6	GND: ground
#7	Not connected
#8	Not connected

Table 7. PN7120 NFC controller board TB3 connector pinout

TB3	PN7120 signal
#1	VBAT/VDD(PAD): 3.3 V supply voltage
#2	I2CSCL: I2C-bus serial clock input
#3	I2CSDA: I2C-bus serial data
#4	IRQ: interrupt request output
#5	VEN: reset pin
#6	GND: ground

7 Product certification

Only the default configuration of the product is considered in below certification statements. Other configurations, described in [Section 6](#), are excluded.

7.1 European Conformity

The PN7120 NFC controller board (see [Section 3.2.1](#)) meets applicable tests and performance criteria for residential, commercial and light industrial environments in European standards:

- EN 301 489-3: Electromagnetic compatibility and Radio spectrum Matters; ElectroMagnetic Compatibility
- EN 50364: Limitation of human exposure to electromagnetic fields
- EN 300 330-2: Electromagnetic compatibility and Radio spectrum Matters; Short Range Devices
- EN 60950-1: Information Technology Equipment - Safety

Electrostatic discharge immunity evaluation not been conducted on the whole accessible parts, the device must be protected against those discharges.

Interface Boards (see [Section 3.2.2](#) and [Section 3.2.3](#)) have not been used during the conformity evaluation then they are not in the scope of the current conformity statement.

The product must be provided with fire enclosure or must be supplied by a limiter power source according to Item 2.5 of EN 60950-1. Power must deliver safety extra low voltage.

Additionally, the current conformity is only applicable in the following conditions:

- Product VBAT power supply is 3.3 V
- Operational temperature is between -20 °C and 55 °C
- Cables used to enforce the product must be of maximum 3 meters length

7.2 Federal Communication Commission Interference Statement

7.2.1 FCC grant

The PN7120 NFC controller board have been tested to fulfil the approval requirements FCC 47 CFR part 15: 2014 (§15.225).

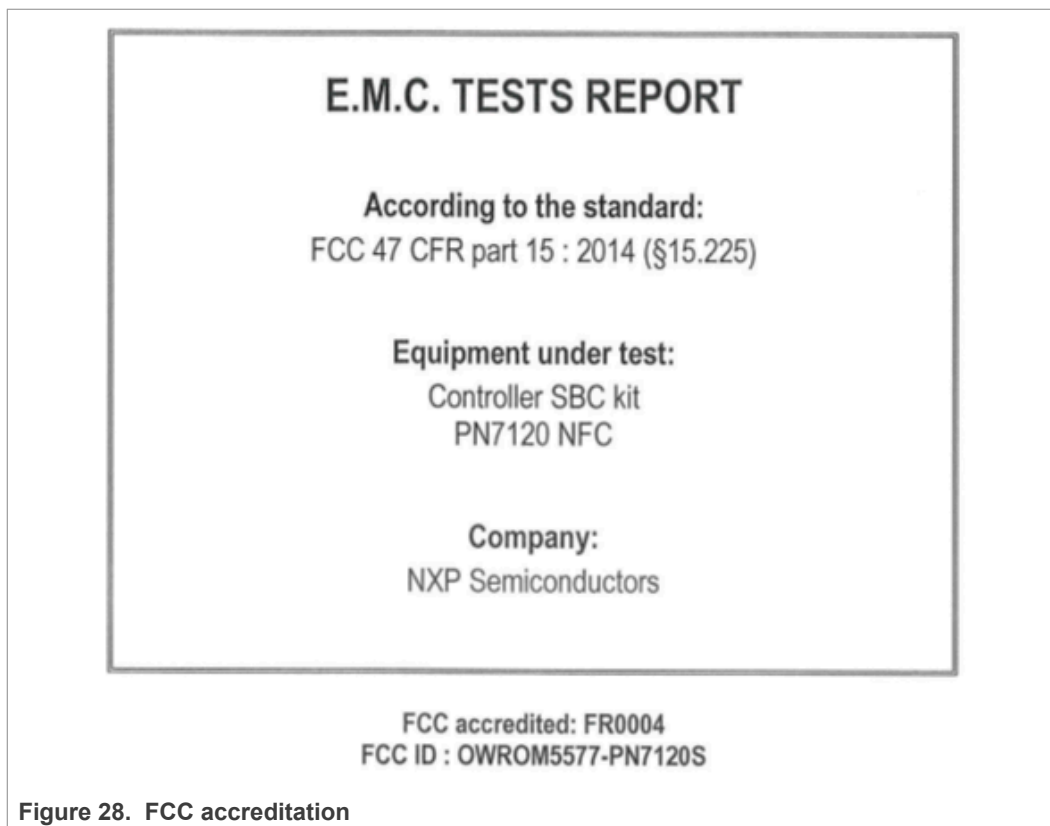

Figure 28. FCC accreditation

7.2.2 Installation instructions

PN7120 NFC controller board can then be reused as a module for integration into end devices following below instruction/restrictions:

- The module is limited to OEM installation ONLY
- The OEM/Integrators are responsible for ensuring that the end user has no manual instructions to remove or install module
- The module is limited to installation in mobile or fixed applications, according to Part 2.1091(b)
- Separate approval is required for all other operating configurations, including portable configurations with respect to Part 2.1093 and different antenna configurations
- Authorized antennas per Part 15.204 (including ant. spec.)
- Antenna installation requirements, where relevant
- The finished product user manual must include following statements:
 - Part 15.19 Warning Statement:

This device complies with part 15 of the FCC rules. Operation is subject to the following two conditions: (1) this device may not cause harmful interference, and (2) this device must accept any interference received, including interference that may cause undesired operation.

- Part 15.21 Warning Statement:

The user manual for an intentional or unintentional radiator shall caution the user that changes or modifications not expressly approved by the party responsible for compliance could void the user's authority to operate the equipment.

Note: The grantee is not responsible for any changes or modifications not expressly approved by the third party responsible for compliance. Such modifications could void the user's authority to operate the equipment.

- End users must be provided with transmitter/antenna installation requirements and operating conditions for satisfying RF exposure compliance:
 - A separate section should clearly state “FCC RF Exposure requirements”
 - Required operating conditions for end users
 - Antenna/or transmitter installation requirements, where relevant (for example: The antenna used with this module must be installed to provide a separation distance of at least 20 cm from all persons, and must not transmit simultaneously with any other antenna or transmitter.)
- « Contains Transmitter module FCC ID:OWROM5577-PN7120S » or «Contains FCC ID: OWROM5577-PN7120S »

8 References

- [1] The Raspberry Pi is a credit card sized computer. The initial idea behind it was to develop a small and cheap computer to be used by kids all over the world to learn programming. In the end, it became very popular among developers all over the world.
The heart of the Raspberry Pi is a SoC (System on Chip). This contains an ARM11 running at 700 MHz and a graphics processor that is capable of Blu-ray quality playback, using H.264 at 40MBits/s. It has a fast 3D core accessed using the supplied OpenGL ES2.0 and Open VG libraries. In addition, the Model B has 512 MB RAM included in its SoC.
To get started quickly, the Raspberry Pi Foundation provides several preconfigured Linux distributions.
For more information about it, please visit <https://www.raspberrypi.org/>
- [2] BeagleBone is a low-power open source hardware single-board credit-card-sized Linux computer that connects to the Internet and runs software such as Android and Ubuntu. With plenty of I/O and processing power for real-time analysis provided by a 720 MHz ARM® processor-based SoC (System on Chip), BeagleBone can be complemented with cape plug-in boards to augment functionality.
For more information about it, please visit <http://beagleboard.org/bone>.
- [3] PN7120 product web page: <https://www.nxp.com/products/rfid-nfc/nfc-hf/nfc-readers/nfc-controller-with-integrated-firmware-and-nci-interface-for-home-appliances:PN7120>

9 Legal information

9.1 Definitions

Draft — A draft status on a document indicates that the content is still under internal review and subject to formal approval, which may result in modifications or additions. NXP Semiconductors does not give any representations or warranties as to the accuracy or completeness of information included in a draft version of a document and shall have no liability for the consequences of use of such information.

9.2 Disclaimers

Limited warranty and liability — Information in this document is believed to be accurate and reliable. However, NXP Semiconductors does not give any representations or warranties, expressed or implied, as to the accuracy or completeness of such information and shall have no liability for the consequences of use of such information. NXP Semiconductors takes no responsibility for the content in this document if provided by an information source outside of NXP Semiconductors. In no event shall NXP Semiconductors be liable for any indirect, incidental, punitive, special or consequential damages (including - without limitation - lost profits, lost savings, business interruption, costs related to the removal or replacement of any products or rework charges) whether or not such damages are based on tort (including negligence), warranty, breach of contract or any other legal theory. Notwithstanding any damages that customer might incur for any reason whatsoever, NXP Semiconductors' aggregate and cumulative liability towards customer for the products described herein shall be limited in accordance with the Terms and conditions of commercial sale of NXP Semiconductors.

Right to make changes — NXP Semiconductors reserves the right to make changes to information published in this document, including without limitation specifications and product descriptions, at any time and without notice. This document supersedes and replaces all information supplied prior to the publication hereof.

Suitability for use — NXP Semiconductors products are not designed, authorized or warranted to be suitable for use in life support, life-critical or safety-critical systems or equipment, nor in applications where failure or malfunction of an NXP Semiconductors product can reasonably be expected to result in personal injury, death or severe property or environmental damage. NXP Semiconductors and its suppliers accept no liability for inclusion and/or use of NXP Semiconductors products in such equipment or applications and therefore such inclusion and/or use is at the customer's own risk.

Applications — Applications that are described herein for any of these products are for illustrative purposes only. NXP Semiconductors makes no representation or warranty that such applications will be suitable for the specified use without further testing or modification. Customers are responsible for the design and operation of their applications and products using NXP Semiconductors products, and NXP Semiconductors accepts no liability for any assistance with applications or customer product design. It is customer's sole responsibility to determine whether the NXP Semiconductors product is suitable and fit for the customer's applications and products planned, as well as for the planned application and use of customer's third party customer(s). Customers should provide appropriate design and operating safeguards to minimize the risks associated with their applications and products. NXP Semiconductors does not accept any liability related to any default, damage, costs or problem which is based on any weakness or default in the customer's applications or products, or the application or use by customer's third party customer(s). Customer is responsible for doing all necessary testing for the customer's applications and products using NXP Semiconductors products in order to avoid a default of the applications and the products or of the application or use by customer's third party customer(s). NXP does not accept any liability in this respect.

Export control — This document as well as the item(s) described herein may be subject to export control regulations. Export might require a prior authorization from competent authorities.

Evaluation products — This product is provided on an "as is" and "with all faults" basis for evaluation purposes only. NXP Semiconductors, its affiliates and their suppliers expressly disclaim all warranties, whether express, implied or statutory, including but not limited to the implied warranties of non-infringement, merchantability and fitness for a particular purpose. The entire risk as to the quality, or arising out of the use or performance, of this product remains with customer. In no event shall NXP Semiconductors, its affiliates or their suppliers be liable to customer for any special, indirect, consequential, punitive or incidental damages (including without limitation damages for loss of business, business interruption, loss of use, loss of data or information, and the like) arising out of the use of or inability to use the product, whether or not based on tort (including negligence), strict liability, breach of contract, breach of warranty or any other theory, even if advised of the possibility of such damages. Notwithstanding any damages that customer might incur for any reason whatsoever (including without limitation, all damages referenced above and all direct or general damages), the entire liability of NXP Semiconductors, its affiliates and their suppliers and customer's exclusive remedy for all of the foregoing shall be limited to actual damages incurred by customer based on reasonable reliance up to the greater of the amount actually paid by customer for the product or five dollars (US\$5.00). The foregoing limitations, exclusions and disclaimers shall apply to the maximum extent permitted by applicable law, even if any remedy fails of its essential purpose.

Translations — A non-English (translated) version of a document is for reference only. The English version shall prevail in case of any discrepancy between the translated and English versions.

Security — Customer understands that all NXP products may be subject to unidentified or documented vulnerabilities. Customer is responsible for the design and operation of its applications and products throughout their lifecycles to reduce the effect of these vulnerabilities on customer's applications and products. Customer's responsibility also extends to other open and/or proprietary technologies supported by NXP products for use in customer's applications. NXP accepts no liability for any vulnerability. Customer should regularly check security updates from NXP and follow up appropriately. Customer shall select products with security features that best meet rules, regulations, and standards of the intended application and make the ultimate design decisions regarding its products and is solely responsible for compliance with all legal, regulatory, and security related requirements concerning its products, regardless of any information or support that may be provided by NXP. NXP has a Product Security Incident Response Team (PSIRT) (reachable at PSIRT@nxp.com) that manages the investigation, reporting, and solution release to security vulnerabilities of NXP products.

9.3 Licenses

Purchase of NXP ICs with NFC technology

Purchase of an NXP Semiconductors IC that complies with one of the Near Field Communication (NFC) standards ISO/IEC 18092 and ISO/IEC 21481 does not convey an implied license under any patent right infringed by implementation of any of those standards. Purchase of NXP Semiconductors IC does not include a license to any NXP patent (or other IP right) covering combinations of those products with other products, whether hardware or software.

9.4 Trademarks

Notice: All referenced brands, product names, service names and trademarks are the property of their respective owners.

i²C-bus — logo is a trademark of NXP B.V.

MIFARE — is a trademark of NXP B.V.

MIFARE Ultralight — is a trademark of NXP B.V.

FeliCa — is a trademark of Sony Corporation.

NXP — wordmark and logo are trademarks of NXP B.V.

Tables

Tab. 1.	Power transfer (Poll mode)	19	Tab. 6.	PN7120 NFC controller board TB2 connector pinout	21
Tab. 2.	Reader/Writer mode performance	19	Tab. 7.	PN7120 NFC controller board TB3 connector pinout	21
Tab. 3.	Peer to Peer mode performances	19			
Tab. 4.	Card mode performance	19			
Tab. 5.	PN7120 NFC controller board TB1 connector pinout	20			

Figures

Fig. 1.	PN7120NFC controller SBC kit content4	Fig. 16.	BeagleBone interface board layer 3 14
Fig. 2.	PN7120 NFC Controller Board5	Fig. 17.	BeagleBone interface board layer 4 14
Fig. 3.	BeagleBone interface board6	Fig. 18.	BeagleBone interface board top silkscreen layer 15
Fig. 4.	Raspberry Pi Interface Board7	Fig. 19.	Raspberry Pi interface board schematics 15
Fig. 5.	MIFARE Ultralight EV1 card8	Fig. 20.	Raspberry Pi interface board top components layers 16
Fig. 6.	PN7120 NFC controller board schematics 9	Fig. 21.	Raspberry Pi Interface board bottom components layers 16
Fig. 7.	PN7120 NFC controller board top components layers 10	Fig. 22.	Raspberry Pi interface board layers 1 and 2 ... 17
Fig. 8.	PN7120 NFC controller board bottom components layers 10	Fig. 23.	Raspberry Pi interface board layer 3 17
Fig. 9.	PN7120 NFC controller board layer 1 11	Fig. 24.	Raspberry Pi interface board layer 4 17
Fig. 10.	PN7120 NFC controller board layer 2 11	Fig. 25.	Raspberry Pi interface board top silkscreen layer 18
Fig. 11.	PN7120 NFC controller board top silkscreen layer 11	Fig. 26.	PN7120 NFC controller board RF antenna components 20
Fig. 12.	BeagleBone Interface Board schematics 12	Fig. 27.	PN7120 NFC controller board interface connectors 21
Fig. 13.	BeagleBone interface board top components layers 12	Fig. 28.	FCC accreditation 23
Fig. 14.	BeagleBone interface board bottom components layers 13		
Fig. 15.	BeagleBone interface board layers 1 and 2 13		

Contents

1 Revision history 2

2 Introduction 3

3 Overview 4

3.1 Kit description 4

3.2 Kit content 4

3.2.1 PN7120 NFC controller board 5

3.2.2 BeagleBone interface board 6

3.2.3 Raspberry Pi interface board 7

3.2.4 MIFARE Ultralight EV1 card 8

4 Details 9

4.1 PN7120 NFC controller board 9

4.1.1 Schematics 9

4.1.2 Layout 10

4.1.2.1 Components layers 10

4.1.2.2 Layer 1 11

4.1.2.3 Layer 2 11

4.1.2.4 Top silkscreen layer 11

4.2 BeagleBone interface board 12

4.2.1 Schematics 12

4.2.2 Layout 12

4.2.2.1 Components layers 12

4.2.2.2 Layers 1 and 2 13

4.2.2.3 Layer 3 14

4.2.2.4 Layer 4 14

4.2.2.5 Top silkscreen layer 15

4.3 Raspberry Pi interface board 15

4.3.1 Schematics 15

4.3.2 Layout 16

4.3.2.1 Components layers 16

4.3.2.2 Layers 1 and 2 17

4.3.2.3 Layer 3 17

4.3.2.4 Layer 4 17

4.3.2.5 Top silkscreen layer 18

5 PN7120 NFC controller board performances 19

6 Additional information 20

6.1 Using different antenna 20

6.2 Using in another system 20

7 Product certification 22

7.1 European Conformity 22

7.2 Federal Communication Commission Interference Statement 22

7.2.1 FCC grant 22

7.2.2 Installation instructions 23

8 References 25

9 Legal information 26

Please be aware that important notices concerning this document and the product(s) described herein, have been included in section 'Legal information'.

© NXP B.V. 2021.

All rights reserved.

For more information, please visit: <http://www.nxp.com>

For sales office addresses, please send an email to: salesaddresses@nxp.com

Date of release: 9 February 2021

Document identifier: UM10878

Document number: 318515