

KIT33663_EFEVB Evaluation Board

Featuring the MC33663 Dual LIN Transceiver

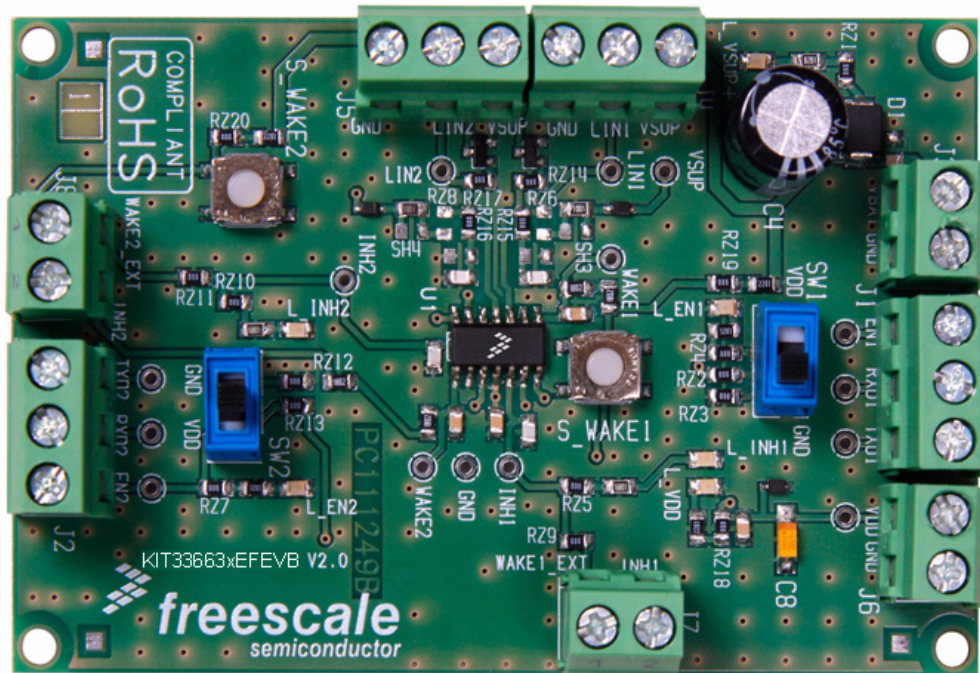

Figure 1. The KIT33663_EFEVB board ('_' = J or L, which describes the transceiver's Baud rate capability)

Table of Contents

1	Kit Contents / Packing List	2
2	Important Notice	3
3	Kit Introduction	4
4	Required Equipment	5
5	EVB Setup Configuration Diagram	6
6	Using Hardware	7
7	EVB Schematic	9
8	Board Layout	10
9	Bill of Material	13
10	References	15
11	Revision History	16

1 Kit Contents / Packing List

- Assembled and tested evaluation board/module in anti-static bag.
- CD-ROM containing:
 - Supporting Documentation for featured device (including data sheet and user's guide)
 - Schematic of evaluation board
 - PCB artwork
 - Bill-of-material for evaluation board
 - Instruction sheet for evaluation board
 - SPIGen 5.0.1 software
- Warranty card

2 Important Notice

Freescale provides the enclosed product(s) under the following conditions:

This evaluation kit is intended for use of ENGINEERING DEVELOPMENT OR EVALUATION PURPOSES ONLY. It is provided as a sample IC pre-soldered to a printed circuit board to make it easier to access inputs, outputs, and supply terminals. This EVB may be used with any development system or other source of I/O signals by simply connecting it to the host MCU or computer board via off-the-shelf cables. This EVB is not a Reference Design and is not intended to represent a final design recommendation for any particular application. Final device in an application will be heavily dependent on proper printed circuit board layout and heat sinking design as well as attention to supply filtering, transient suppression, and I/O signal quality.

The goods provided may not be complete in terms of required design, marketing, and or manufacturing related protective considerations, including product safety measures typically found in the end product incorporating the goods. Due to the open construction of the product, it is the user's responsibility to take any and all appropriate precautions with regard to electrostatic discharge. In order to minimize risks associated with the customers applications, adequate design and operating safeguards must be provided by the customer to minimize inherent or procedural hazards. For any safety concerns, contact Freescale sales and technical support services.

Should this evaluation kit not meet the specifications indicated in the kit, it may be returned within 30 days from the date of delivery and will be replaced by a new kit.

Freescale reserves the right to make changes without further notice to any products herein. Freescale makes no warranty, representation or guarantee regarding the suitability of its products for any particular purpose, nor does Freescale assume any liability arising out of the application or use of any product or circuit, and specifically disclaims any and all liability, including without limitation consequential or incidental damages. "Typical" parameters can and do vary in different applications and actual performance may vary over time. All operating parameters, including "Typical", must be validated for each customer application by customer's technical experts.

Freescale does not convey any license under its patent rights nor the rights of others. Freescale products are not designed, intended, or authorized for use as components in systems intended for surgical implant into the body, or other applications intended to support or sustain life, or for any other application in which the failure of the Freescale product could create a situation where personal injury or death may occur.

Should the buyer purchase or use Freescale products for any such unintended or unauthorized application, the buyer shall indemnify and hold Freescale and its officers, employees, subsidiaries, affiliates, and distributors harmless against all claims, costs, damages, and expenses, and reasonable attorney fees arising out of, directly or indirectly, any claim of personal injury or death associated with such unintended or unauthorized use, even if such claim alleges that Freescale was negligent regarding the design or manufacture of the part. Freescale and the Freescale logo are trademarks of Freescale Semiconductor, Inc. All other product or service names are the property of their respective owners.
© Freescale Semiconductor, Inc. 2012.

3 Kit Introduction

The KIT33663_EFEVB evaluation board was designed to demonstrate the capabilities of the MC33663 Dual LIN transceiver IC. The local interconnect network (LIN) is a serial communication protocol designed to support automotive networks in conjunction with controller area network (CAN). This kit is populated with a production device and gives you the opportunity to test the device in various configurations. This kit can also be used for ESD and BCI tests.

3.1 Evaluation Board Features

There are two variants of KIT33663_EFEVB board, as distinguished by the underscore character in the kit name, which can stand for either the letter *L* or *J*: The KIT33663LEFEVB has an MC33663LEF mounted as its principal device. The KIT33663JEFEVB has an MC33663JEF device instead. Both devices are members of the same Dual LIN Transceiver product line. Aside from this distinction, the two board variants are identical and possess the following features:

- Individually routed power supply inputs for VDD and VBAT
- The two LIN bus controllers operate independently:
 - Separate switches enable each controller
 - Board status indicated by six LEDs
 - Slave or Master configuration via shunt resistors
 - Separate push-buttons wake up each controller from sleep mode
 - Test points for every pin

3.2 MC33663 Device Features

The MC33663 product line integrates two physical layer LIN buses dedicated to automotive LIN sub-bus applications. The MC33663LEF device offers normal baud rate (20 kbps) and the MC33663JEF, a slower baud rate (10 kbps). All devices integrate the fast baud rate (above 100 kbps) for test and programming modes. Common features of the two devices include:

- One supply, operational from a V_{SUP} of 7.0 to 18 V DC, functional up to 27 V DC, and handles 40 V during Load Dump
- Compatible with LIN Protocol Specification 1.3, 2.0, 2.1, and SAEJ2602-2
- Active bus wave shaping offering excellent radiated emission performance
- Sustains 15.0 kV minimum ESD IEC6100-4-2 on the LIN Bus, WAKE and VSUP pins
- Very high immunity against electromagnetic interference
- Low standby current in Sleep mode
- Over-temperature protection

- Local and Remote Wake-up capability reported by the RXD pin
- Fast baud rate mode selection reported by RXD
- 5.0 V and 3.3 V compatible digital inputs without any required external components

4 Required Equipment

To use this kit you need:

- +12 V DC power supply
- +5.0 V DC power supply
- 0/+5.0 V Waveform generator
- Oscilloscope

5 EVb Setup Configuration Diagram

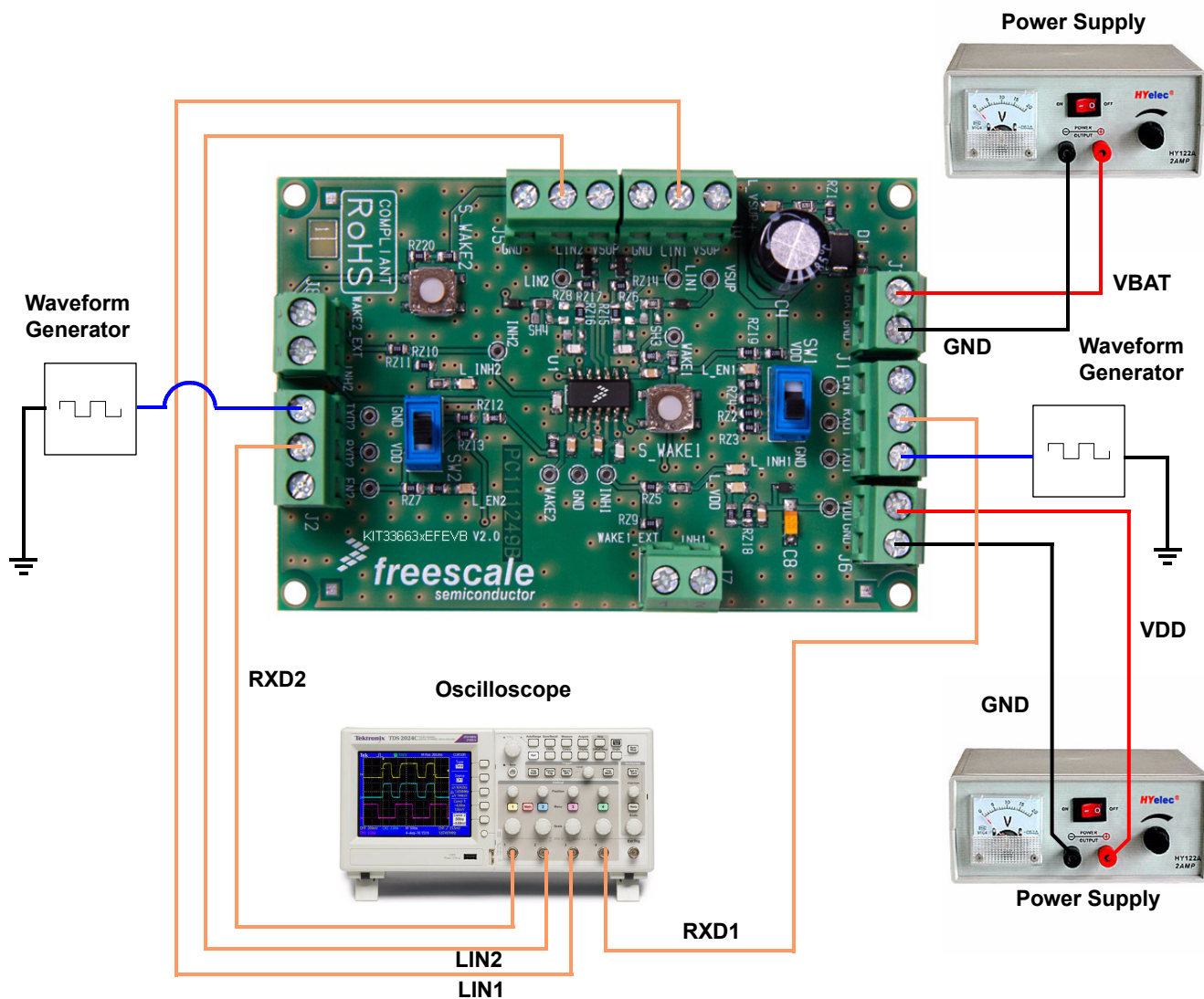

Figure 2. EVb Setup Configuration Diagram

6 Using Hardware

6.1 Jumper Connections

RZ1	Enable LED for VSUP state (set by default)
RZ18	Enable LED for VDD state (set by default)
RZ4	Enable LED for EN1 state (set by default)
RZ7	Enable LED for EN2 state (set by default)
RZ5	Enable LED for INH1 state (set by default)
RZ10	Enable LED for INH2 state (set by default)
RZ15	Add C6 (68 pF) on LIN1 bus (set by default)
RZ16	Add C7 (68 pF) on LIN2 bus (set by default)
RZ14	Add ESD1 on LIN1 bus (set by default)
RZ17	Add ESD2 on LIN2 bus (set by default)
RZ9	Add capacitor load (100 pF) on INH1 BUS (set by default)
RZ11	Add capacitor load (100 pF) on INH2 BUS (set by default)
RZ2	Can be changed to limit current on EN1 pin (0 Ohm resistor by default)
RZ3	Can be changed to limit current on EN1 pin (0 Ohm resistor by default)
RZ12	Can be changed to limit current on EN2 pin (0 Ohm resistor by default)
RZ13	Can be changed to limit current on EN2 pin* (0 Ohm resistor by default)
SW1	Connect EN1 pin to: - VDD(1) - EN1 connector(2) - GND(3)
SW2	Connect EN2 pin to: - VDD(1) - EN2 connector(2) - GND(3)
S_WAKE1	Push button to change WAKE1 pin value
S_WAKE2	Push button to change WAKE2 pin value
RZ19	Set (default): allows use of S_WAKE1 by connecting VBAT pull-up Not set: allows use of external wake source
RZ20	Set (default): allows use of S_WAKE2 by connecting VBAT pull-up Not set: allows use of external wake source
SH1	Slot to change the load value on LIN1 bus (not set by default)
SH2	Slot to change the load value on LIN2 bus (not set by default)

6.2 Simplified Input/Output Diagram

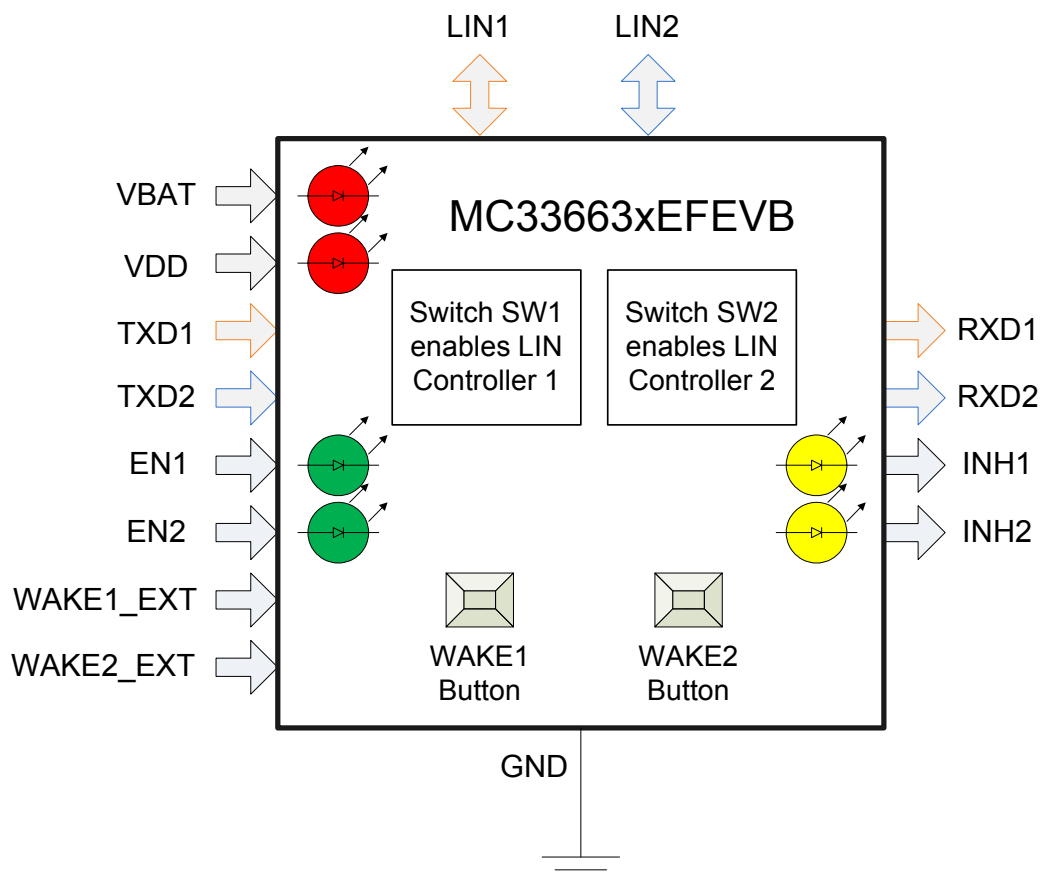
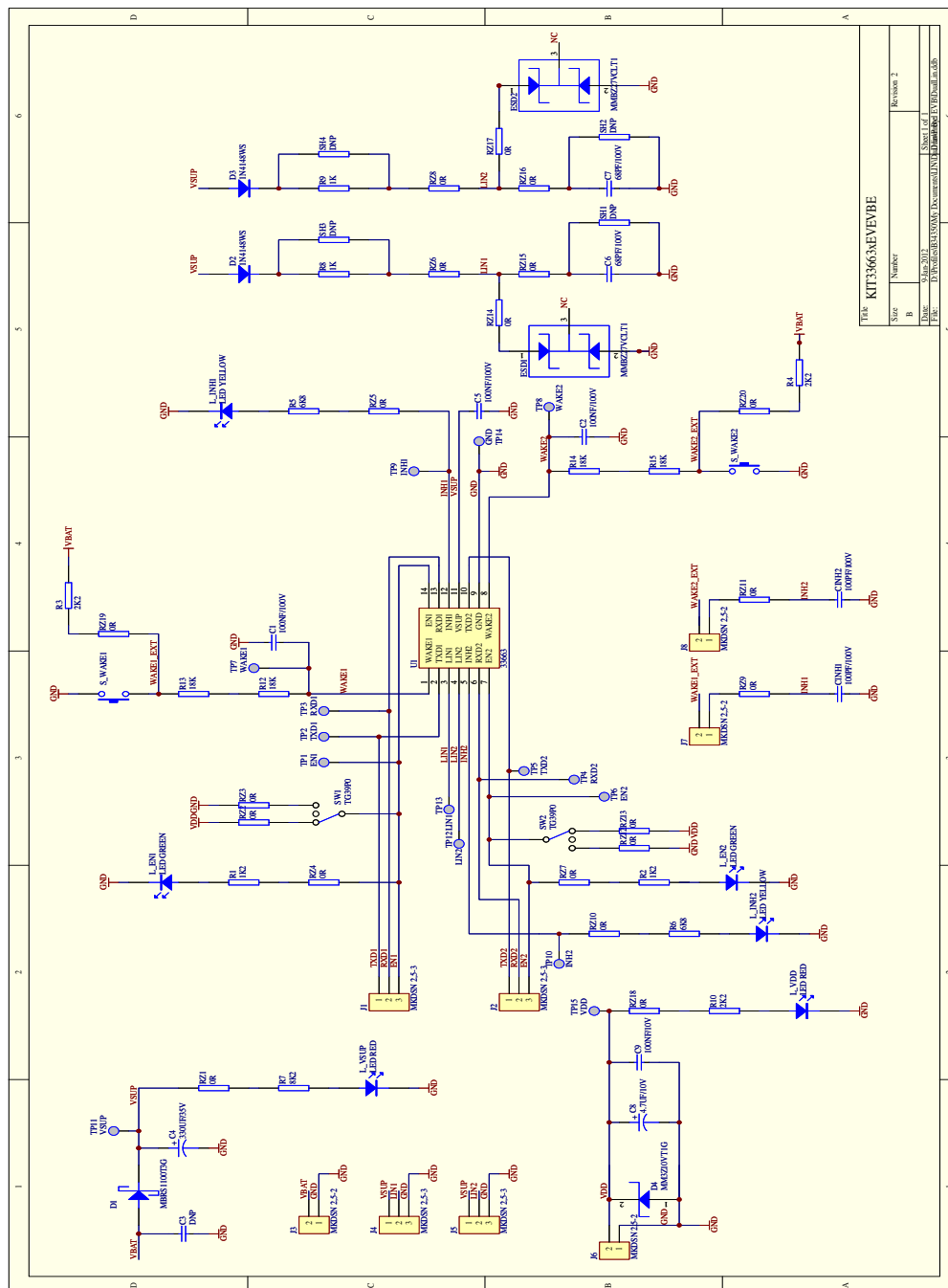

Figure 3. Evaluation Board Signals and Power/Ground Lines

7 EVB Schematic



Task: KIT33663EVB/EVB		Revision: 2
Size: B	Number: 1	Sheet 1 of 1
Date: 2/16/2012	File: C:\Freescale\KIT33663EVB\Documents\KIT33663EVB\KIT33663EVB_Sch.mxd	

Figure 4. EVB Schematic

8 Board Layout

8.1 Assembly Layer Top

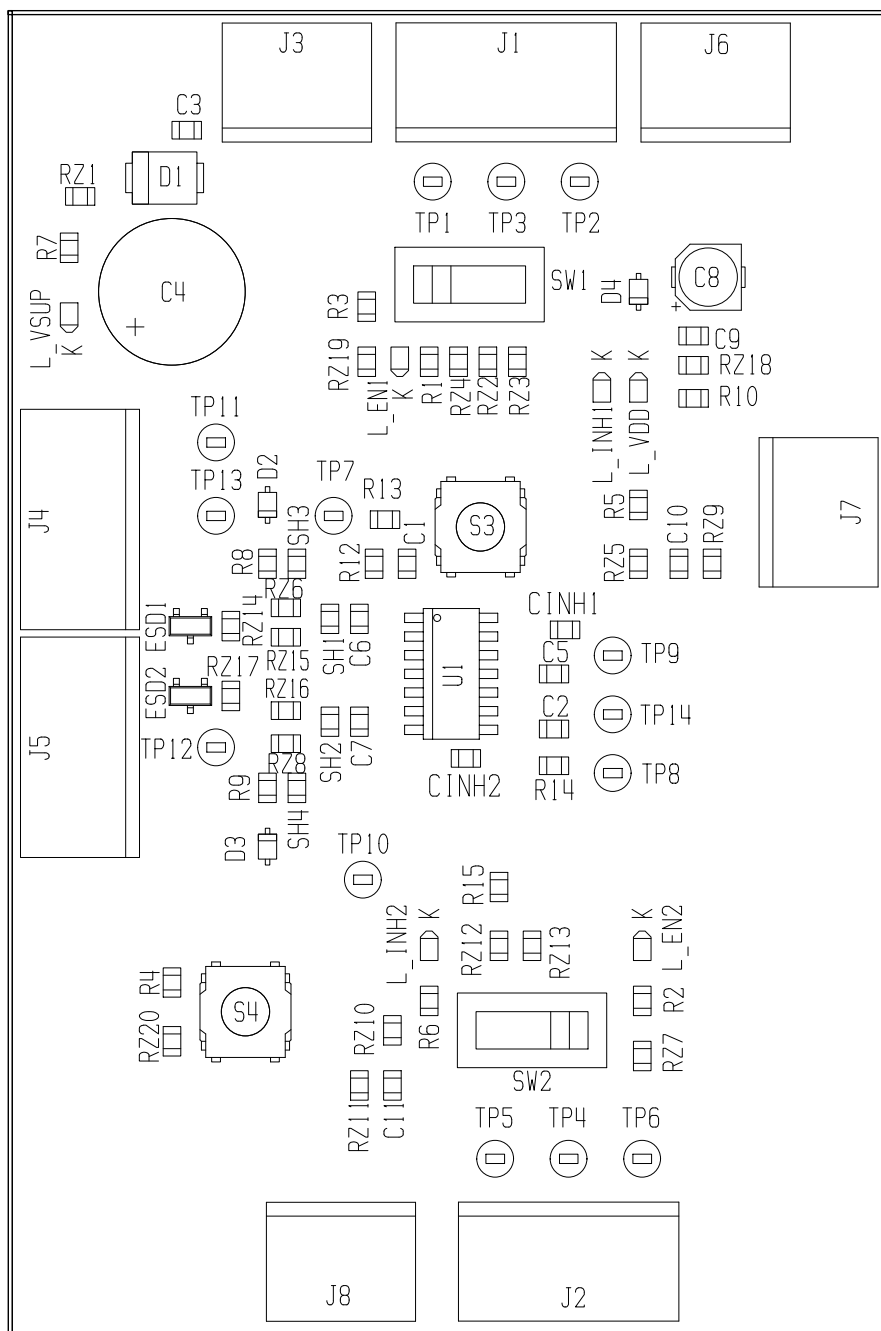

Figure 5. Assembly Layer Top

8.2 Top Layer Routing

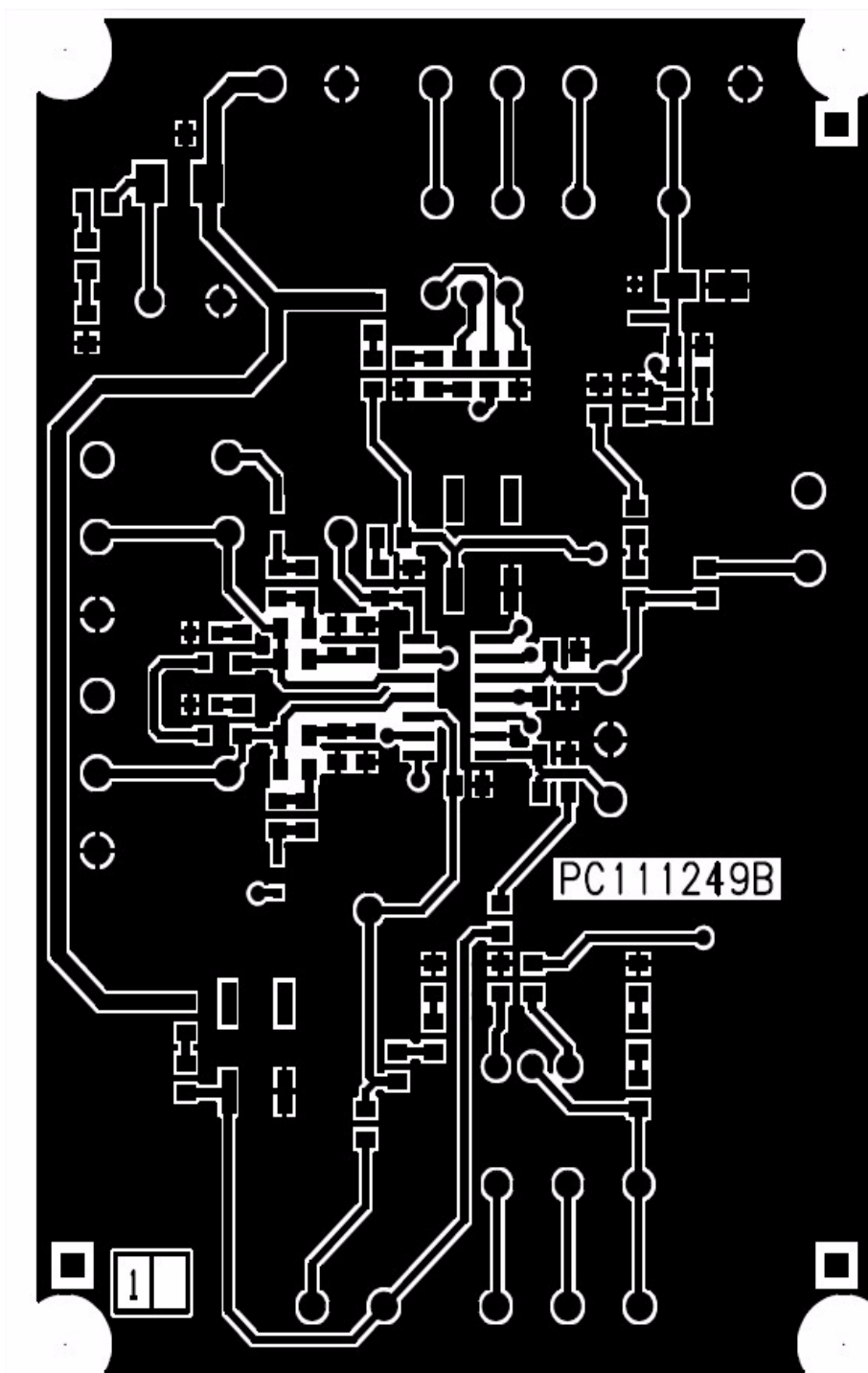

Figure 6. Top Layer Routing

8.3 Bottom Layer Routing

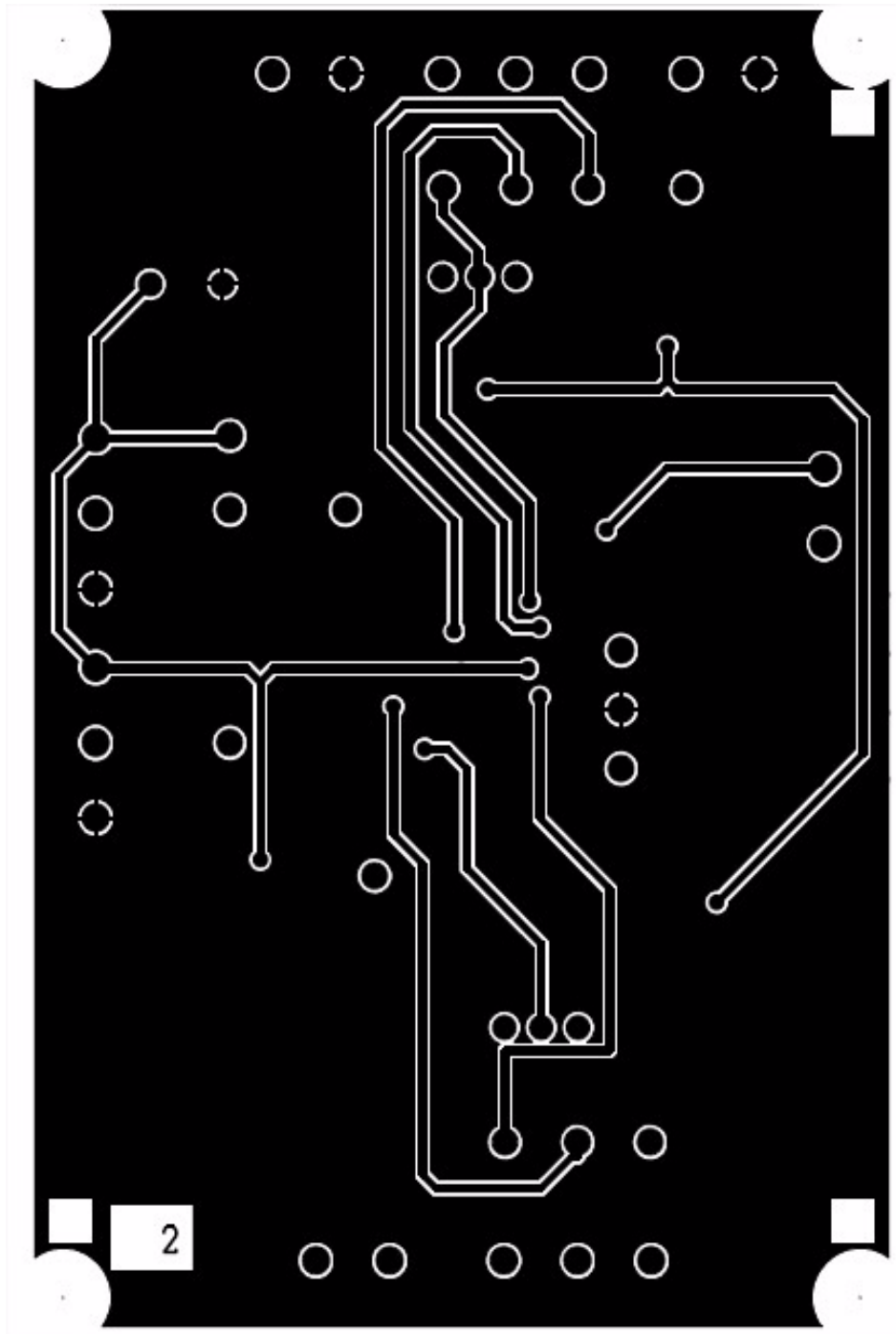

Figure 7. Bottom Layer Routing

9 Bill of Material

Item	Quantity	Schematic Label	Part Number/Value	Footprint	Description
Freescale IC					
1	1	U1	MC33663LEF for KIT33663LEFEVB, MC33663JEF for KIT33663JEFEVB	SO14	Dual LIN Transceiver
Diodes					
2	1	D1	MBRS1100T3G	DO214-AA (SMB)	Schottky 1.0 A 100 V - SMB
3	2	D2, D3	1N4148WS	SOD323	DIODE 150 mA 53 V - SOD-323
4	1	D4	MM3Z10VT1G	SOD323	Zener 10 V 5% 200 mW - SOD-323
5	2	ESD1, ESD2	MMBZ27VCLT1	SOT23	Dual Common Cathode Zeners - SOT-23
LEDs					
6	2	L_EN1, L_EN2	LXT0805GW	CR-0805	LED GREEN 20mA
7	2	L_INH1, L_INH2	LXT0805YW	CR-0805	LED YELLOW 20mA
8	1	L_VDD	LXT0805RW	CR-0805	LED RED 20mA
9	1	L_VSUP	LXT0805RW	CR-0805	LED RED 20mA
Capacitors					
10	3	C1, C2, C5	100 nF/100 V	805	CAP CER 10% - X7R 0805
11	1	C3	DNP	805	
12	1	C4	330 μ F/35 V	CPT ECA DIA10 01	CAP ALEL 20% - RADIAL
13	2	C6, C7	68 pF/100 V	805	CAP CER 10% - X7R 0805
14	1	C8	4.7 μ F/10 V	SMD ALE A	CAP ALEL 20% - RADIAL
15	1	C9	100 nF/10 V	805	CAP CER 10% - X7R 0805
16	2	CINH1, CINH2	100 pF/100 V	805	CAP CER 10% - X7R 0805
Resistors					
17	2	R1, R2	1K2	805	RES TF 1/8 W 1% - RC0805
18	3	R3, R4, R10	2K2	805	RES TF 1/8 W 1% - RC0805
19	2	R5, R6	6K8	805	RES TF 1/8 W 1% - RC0805
20	1	R7	8K2	805	RES TF 1/8 W 1% - RC0805
21	2	R8, R9	1K	805	RES TF 1/8 W 1% - RC0805
22	4	R12, R13, R14, R15	18K	805	RES TF 1/8 W 1% - RC0805
23	4	RZ1, RZ2, RZ3, RZ4	0R	805	RES 0 - RC0805
24	4	RZ5, RZ6, RZ7, RZ8	0R	805	RES 0 - RC0805
25	3	RZ9, RZ10, RZ11	0R	805	RES 0 - RC0805
26	3	RZ12, RZ13, RZ14	0R	805	RES 0 - RC0805
27	3	RZ15, RZ16, RZ17	0R	805	RES 0 - RC0805

Bill of Material

Item	Quantity	Schematic Label	Part Number/Value	Footprint	Description
28	3	RZ18, RZ19, RZ20	0R	805	RES 0 - RC0805
29	4	SH1, SH2, SH3, SH4	DNP	805	
Push buttons, Switches, Jumpers and Connectors					
30	2	S_WAKE1, S_WAKE2	KSC221J 32 V/50 mA	SWS KSC 01	SW SPST SMT
31	2	SW1, SW2	TG39P0 20 V/0.4 A	SWT TG39P0	SPDT ON-OFF-ON
32	4	J1, J2, J4, J5	PCB 3WAY 250 V/16 A	JMT MKDSN 3PTS 01	MKDSN 2,5-3
33	4	J3, J6, J7, J8	PCB 2WAY 250 V/16 A	JMT MKDSN 2PTS 01	MKDSN 2,5-2

Freescale does not assume liability, endorse, or warrant components from external manufacturers that are referenced in circuit drawings or tables. While Freescale offers component recommendations in this configuration, it is the customer's responsibility to validate their application

10 References

Following are URLs where you can obtain information on other Freescale products and application solutions:

Document Number	Description	URL
MC33663	Data Sheet	http://cache.freescale.com/files/analog/doc/data_sheet/MC33663.pdf
MC33663FS	Fact Sheet	http://cache.freescale.com/files/analog/doc/fact_sheet/MC33663FS.pdf
	Product Summary Page	http://www.freescale.com/webapp/sps/site/prod_summary.jsp?code=MC33663
AN2409	“Small Outline Integrated Circuit Fine Pitch Package (SOIC)” Application Note	http://cache.freescale.com/files/analog/doc/app_note/AN2409.pdf
	Automotive Home Page	www.freescale.com/automotive

10.1 Support

Visit Freescale.com/support for a list of phone numbers within your region.

10.2 Warranty

Visit Freescale.com/warranty for a list of phone numbers within your region.

11 Revision History

Table 1. Revision History

Revision	Date	Description of Changes
1.0	12/2012	<ul style="list-style-type: none"> Initial Release

How to Reach Us:**Home Page:**

freescale.com

Web Support:

freescale.com/support

Information in this document is provided solely to enable system and software implementers to use Freescale products. There are no express or implied copyright licenses granted hereunder to design or fabricate any integrated circuits on the information in this document.

Freescale reserves the right to make changes without further notice to any products herein. Freescale makes no warranty, representation, or guarantee regarding the suitability of its products for any particular purpose, nor does Freescale assume any liability arising out of the application or use of any product or circuit, and specifically disclaims any and all liability, including without limitation consequential or incidental damages. "Typical" parameters that may be provided in Freescale data sheets and/or specifications can and do vary in different applications, and actual performance may vary over time. All operating parameters, including "typicals," must be validated for each customer application by customer's technical experts. Freescale does not convey any license under its patent rights nor the rights of others. Freescale sells products pursuant to standard terms and conditions of sale, which can be found at the following address: <http://www.reg.net/v2/webservices/Freescale/Docs/TermsandConditions.htm>

Freescale, the Freescale logo, Altivec, C-5, CodeTest, CodeWarrior, ColdFire, C-Ware, Energy Efficient Solutions logo, mobileGT, PowerQUICC, QorIQ, Qorivva, StarCore, and Symphony are trademarks of Freescale Semiconductor, Inc., Reg. U.S. Pat. & Tm. Off. Airfast, BeeKit, BeeStack, ColdFire+, CoreNet, Flexis, MagniV, MXC, Platform in a Package, Processor expert, QorIQ Qonverge, QUICC Engine, Ready Play, SMARTMOS, TurboLink, Vybrid, and Xtrinsic are trademarks of Freescale Semiconductor, Inc. All other product or service names are the property of their respective owners.

© 2012 Freescale Semiconductor, Inc.

Document Number: KT33663EFUG

Rev. 1.0

12/2012