

PXR40 Microcontroller Reference Manual

Devices Supported:

PXR4030

PXR4040

PXR40RM

Rev. 1

06/2011



How to Reach Us:

Home Page:

www.freescale.com

Web Support:

<http://www.freescale.com/support>

USA/Europe or Locations Not Listed:

Freescale Semiconductor, Inc.
Technical Information Center, EL516
2100 East Elliot Road
Tempe, Arizona 85284
1-800-521-6274 or +1-480-768-2130
www.freescale.com/support

Europe, Middle East, and Africa:

Freescale Halbleiter Deutschland GmbH
Technical Information Center
Schatzbogen 7
81829 Muenchen, Germany
+44 1296 380 456 (English)
+46 8 52200080 (English)
+49 89 92103 559 (German)
+33 1 69 35 48 48 (French)
www.freescale.com/support

Japan:

Freescale Semiconductor Japan Ltd.
Headquarters
ARCO Tower 15F
1-8-1, Shimo-Meguro, Meguro-ku,
Tokyo 153-0064
Japan
0120 191014 or +81 3 5437 9125
support.japan@freescale.com

Asia/Pacific:

Freescale Semiconductor China Ltd.
Exchange Building 23F
No. 118 Jianguo Road
Chaoyang District
Beijing 100022
China
+86 10 5879 8000
support.asia@freescale.com

For Literature Requests Only:

Freescale Semiconductor Literature Distribution Center
P.O. Box 5405
Denver, Colorado 80217
1-800-441-2447 or +1-303-675-2140
Fax: +1-303-675-2150
LDCForFreescaleSemiconductor@hibbertgroup.com

Information in this document is provided solely to enable system and software implementers to use Freescale Semiconductor products. There are no express or implied copyright licenses granted hereunder to design or fabricate any integrated circuits or integrated circuits based on the information in this document.

Freescale Semiconductor reserves the right to make changes without further notice to any products herein. Freescale Semiconductor makes no warranty, representation or guarantee regarding the suitability of its products for any particular purpose, nor does Freescale Semiconductor assume any liability arising out of the application or use of any product or circuit, and specifically disclaims any and all liability, including without limitation consequential or incidental damages. "Typical" parameters that may be provided in Freescale Semiconductor data sheets and/or specifications can and do vary in different applications and actual performance may vary over time. All operating parameters, including "Typicals", must be validated for each customer application by customer's technical experts. Freescale Semiconductor does not convey any license under its patent rights nor the rights of others. Freescale Semiconductor products are not designed, intended, or authorized for use as components in systems intended for surgical implant into the body, or other applications intended to support or sustain life, or for any other application in which the failure of the Freescale Semiconductor product could create a situation where personal injury or death may occur. Should Buyer purchase or use Freescale Semiconductor products for any such unintended or unauthorized application, Buyer shall indemnify and hold Freescale Semiconductor and its officers, employees, subsidiaries, affiliates, and distributors harmless against all claims, costs, damages, and expenses, and reasonable attorney fees arising out of, directly or indirectly, any claim of personal injury or death associated with such unintended or unauthorized use, even if such claim alleges that Freescale Semiconductor was negligent regarding the design or manufacture of the part.

Freescale™ and the Freescale logo are trademarks of Freescale Semiconductor, Inc. All other product or service names are the property of their respective owners.
The Power Architecture and Power.org word marks and the Power and Power.org logos and related marks are trademarks and service marks licensed by Power.org.

© Freescale Semiconductor, Inc. 2011. All rights reserved.

PXR40RM
Rev. 1
06/2011



Table of Contents

Chapter 1 Introduction

| | | |
|--------|---|------|
| 1.1 | PXR40 features | 1-1 |
| 1.1.1 | Block diagram | 1-3 |
| 1.1.2 | Critical Performance Parameters | 1-4 |
| 1.1.3 | Low-power modes | 1-4 |
| 1.2 | Packages | 1-4 |
| 1.2.1 | Chip-level features | 1-4 |
| 1.2.2 | Module features | 1-5 |
| 1.2.3 | High-performance e200z7 core processor | 1-5 |
| 1.2.4 | On-chip flash memory | 1-6 |
| 1.2.5 | General-purpose static RAM (SRAM) | 1-7 |
| 1.2.6 | Error correction status module (ECSM) | 1-7 |
| 1.2.7 | Enhanced modular input output system (Timer—eMIOS) | 1-8 |
| 1.2.8 | Enhanced timing processor unit (eTPU2) | 1-8 |
| 1.2.9 | Software watchdog timer (SWT) | 1-9 |
| 1.2.10 | Periodic interrupt timer (PIT) | 1-10 |
| 1.2.11 | System timer module (STM) | 1-10 |
| 1.2.12 | Enhanced queued analog to digital converter (eQADC) | 1-10 |
| 1.2.13 | Serial peripheral interface module (SPI) | 1-12 |
| 1.2.14 | Serial communication interface module (UART) | 1-13 |
| 1.2.15 | Controller area network (CAN) module | 1-13 |
| 1.2.16 | Enhanced direct memory access controller (eDMA2) | 1-14 |
| 1.2.17 | Crossbar switch (XBAR) | 1-15 |
| 1.2.18 | Power management unit (PMU) | 1-16 |
| 1.2.19 | Interrupt controller (INTC) | 1-16 |
| 1.2.20 | Frequency-modulated PLL (FMPLL) | 1-17 |
| 1.2.21 | System Integration Unit (SIU) | 1-18 |
| 1.2.22 | Boot assist module (BAM) | 1-18 |
| 1.2.23 | Dual-channel FlexRay controller | 1-19 |
| 1.2.24 | JTAG controller (JTAGC) | 1-20 |
| 1.2.25 | Nexus | 1-21 |
| 1.3 | Developer Environment | 1-22 |

Chapter 2 Memory Map

| | | |
|-----|--------------|-----|
| 2.1 | Introduction | 2-1 |
|-----|--------------|-----|

Chapter 3 Signal Descriptions

| | | |
|-------|--|------|
| 3.1 | Pin Function Selection | 3-1 |
| 3.1.1 | Pad Configuration Register (PCR) PA Definition | 3-1 |
| 3.1.2 | LVDS Signal Selection | 3-1 |
| 3.2 | External Signal Descriptions, Pin Multiplexing, and Attributes | 3-3 |
| 3.3 | Detailed Signal Description | 3-43 |
| 3.3.1 | eTPU Signals | 3-43 |
| 3.3.2 | IRQ and GPIO Signals | 3-44 |
| 3.3.3 | eMIOS Signals | 3-45 |
| 3.3.4 | eQADC Signals | 3-46 |
| 3.3.5 | FlexRay Signals | 3-46 |
| 3.3.6 | FlexCAN Signals | 3-47 |
| 3.3.7 | eSCI Signals | 3-47 |
| 3.3.8 | DSPI Signals | 3-48 |
| 3.3.9 | EBI Signals | 3-50 |

| | |
|--|------|
| 3.3.10 Reset and Clock Signals | 3-51 |
| 3.3.11 JTAG and Nexus Signals | 3-52 |
| 3.3.12 PMC and Power/Voltage Signals | 3-53 |

Chapter 4 Resets

| | |
|---|------|
| 4.1 Reset Sources | 4-1 |
| 4.2 Reset Vector | 4-2 |
| 4.3 Reset Pins | 4-2 |
| 4.3.1 RESET | 4-2 |
| 4.3.2 RSTOUT | 4-3 |
| 4.4 FMPLL Lock Gating Signal | 4-3 |
| 4.5 Reset Source Descriptions | 4-3 |
| 4.5.1 Power-on Reset (POR) | 4-6 |
| 4.5.2 External Reset | 4-6 |
| 4.5.3 Loss of Lock | 4-6 |
| 4.5.4 Loss of Clock | 4-7 |
| 4.5.5 Core Watchdog Timer/Debug Reset | 4-7 |
| 4.5.6 JTAG Reset | 4-7 |
| 4.5.7 Software System Reset | 4-8 |
| 4.5.8 Software External Reset | 4-8 |
| 4.6 Reset Registers in the SIU | 4-8 |
| 4.7 Reset Configuration | 4-9 |
| 4.7.1 Reset Configuration Half Word (RCHW) | 4-9 |
| 4.7.1.1 RCHW Overview | 4-9 |
| 4.7.1.2 RCHW Structure | 4-9 |
| 4.7.2 Reset Configuration Timing | 4-11 |
| 4.7.3 Reset Weak Pull Up/Down Configuration | 4-11 |

Chapter 5 Power Management Controller (PMC)

| | |
|---|------|
| 5.1 Introduction | 5-1 |
| 5.1.1 Features | 5-1 |
| 5.1.1.1 Analog PMC_SMPS features | 5-2 |
| 5.1.1.2 Digital PMC_SMPS features | 5-2 |
| 5.1.2 Block Diagram | 5-3 |
| 5.1.3 PMC Operation Modes | 5-3 |
| 5.2 External Signals Description | 5-4 |
| 5.2.1 Signals Information | 5-4 |
| 5.3 Signals Details | 5-4 |
| 5.3.1 VDDREG | 5-4 |
| 5.3.2 VDD | 5-5 |
| 5.3.3 VDDSYN | 5-5 |
| 5.3.4 VSS | 5-5 |
| 5.3.5 REGCTL | 5-5 |
| 5.3.6 REGSEL | 5-5 |
| 5.3.7 VDD33 | 5-5 |
| 5.4 Memory Map/Register Definition | 5-6 |
| 5.4.1 Configuration Register (PMC_MCR) | 5-6 |
| 5.4.2 Trimming Register (PMC_TRIMR) | 5-8 |
| 5.4.3 Status Register (PMC_SR) | 5-12 |
| 5.5 Functional Description | 5-14 |
| 5.5.1 PMC Internal 1.2V Voltage Regulator Selection | 5-15 |
| 5.5.2 PMC Bandgap | 5-16 |
| 5.5.3 VDDREG LVD | 5-16 |
| 5.5.4 3.3V Internal Voltage Regulator | 5-16 |
| 5.5.5 3.3V VDDSYN LVD | 5-17 |
| 5.5.6 1.2V Voltage Regulator Controller | 5-18 |
| 5.5.7 1.2V VDD LVD | 5-19 |
| 5.5.8 Trimming | 5-20 |

| | | |
|--------|---------------------------------|------|
| 5.5.9 | Interrupts | 5-20 |
| 5.5.10 | PMC Power-on Reset | 5-20 |
| 5.5.11 | ADC Test Mux | 5-22 |
| 5.6 | Initialization | 5-23 |
| 5.7 | Application Information | 5-23 |
| 5.7.1 | Regulator Example | 5-23 |
| 5.7.2 | Hardware Design Recommendations | 5-24 |

Chapter 6 Frequency Modulated Phase-Locked Loop (FMPLL)

| | | |
|---------|---|------|
| 6.1 | Introduction | 6-1 |
| 6.1.1 | Block Diagram | 6-2 |
| 6.1.2 | Features | 6-2 |
| 6.1.3 | Modes of Operation | 6-3 |
| 6.2 | External Signal Description | 6-3 |
| 6.3 | Memory Map and Registers | 6-3 |
| 6.3.1 | Module Memory Map | 6-3 |
| 6.3.2 | Register Descriptions | 6-4 |
| 6.3.2.1 | FMPLL Synthesizer Status Register (SYNSR) | 6-4 |
| 6.3.2.2 | FMPLL Enhanced Synthesizer Control Register 1 (ESYNCR1) | 6-7 |
| 6.3.2.3 | FMPLL Enhanced Synthesizer Control Register 2 (ESYNCR2) | 6-9 |
| 6.3.2.4 | FMPLL Synthesizer FM Control Register (SYNFMCR) | 6-12 |
| 6.4 | Functional Description | 6-14 |
| 6.4.1 | General | 6-14 |
| 6.4.2 | PLL Off Mode | 6-14 |
| 6.4.3 | Normal Mode | 6-15 |
| 6.4.3.1 | PLL Lock Detection | 6-15 |
| 6.4.3.2 | Loss-of-Clock Detection | 6-16 |
| 6.4.3.3 | PLL Normal Mode Without FM | 6-17 |
| 6.4.3.4 | PLL Normal Mode With Frequency Modulation | 6-19 |
| 6.5 | Resets | 6-22 |
| 6.5.1 | Clock Mode Selection | 6-22 |
| 6.5.1.1 | Power-On Reset (POR) | 6-22 |
| 6.5.1.2 | External Reset | 6-22 |
| 6.5.2 | PLL Loss-of-Lock Reset | 6-23 |
| 6.5.3 | PLL Loss-of-Clock Reset | 6-23 |
| 6.6 | Interrupts | 6-23 |
| 6.6.1 | Loss-of-Lock Interrupt Request | 6-23 |
| 6.6.2 | Loss-of-Clock Interrupt Request | 6-23 |

Chapter 7 System Integration Unit (SIU)

| | | |
|---------|---|------|
| 7.1 | Introduction | 7-1 |
| 7.1.1 | Block Diagram | 7-2 |
| 7.1.2 | Overview | 7-3 |
| 7.1.3 | Modes of Operation | 7-3 |
| 7.2 | External Signal Description | 7-4 |
| 7.2.1 | Detailed Signal Descriptions | 7-4 |
| 7.2.1.1 | Reset Input (RESET) | 7-4 |
| 7.2.1.2 | Reset Output (RSTOUT) | 7-5 |
| 7.2.1.3 | General-Purpose I/O (GPIO _n) | 7-5 |
| 7.2.1.4 | Boot Configuration (BOOTCFG[0:1]) | 7-5 |
| 7.2.1.5 | I/O Weak Pullup Reset Configuration (WKPCFG) | 7-6 |
| 7.2.1.6 | External Interrupt Request Input (IRQ) | 7-6 |
| 7.3 | Memory Map and Register Definition | 7-7 |
| 7.3.1 | Register Descriptions | 7-10 |
| 7.3.1.1 | MCU ID Register (SIU_MIDR) | 7-10 |
| 7.3.1.2 | Reset Status Register (SIU_RSR) | 7-11 |
| 7.3.1.3 | System Reset Control Register (SIU_SRCR) | 7-15 |
| 7.3.1.4 | External Interrupt Status Register (SIU_EISR) | 7-15 |

| | | |
|----------|--|------|
| 7.3.1.5 | DMA/Interrupt Request Enable Register (SIU_DIRER) | 7-16 |
| 7.3.1.6 | DMA/Interrupt Request Select Register (SIU_DIRSR) | 7-17 |
| 7.3.1.7 | Overrun Status Register (SIU_OSRR) | 7-18 |
| 7.3.1.8 | Overrun Request Enable Register (SIU_ORER) | 7-19 |
| 7.3.1.9 | IRQ Rising-Edge Event Enable Register (SIU_IREER) | 7-20 |
| 7.3.1.10 | IRQ Falling-Edge Event Enable Register (SIU_IFEER) | 7-21 |
| 7.3.1.11 | IRQ Digital Filter Register (SIU_IDFR) | 7-22 |
| 7.3.1.12 | IRQ Filtered Input Register (SIU_IFIR) | 7-22 |
| 7.3.1.13 | Pad Configuration Registers (SIU_PCR) | 7-24 |
| 7.3.1.14 | GPIO Pin Data Output Registers 0–512 (SIU_GPDOn) | 7-40 |
| 7.3.1.15 | GPIO Pin Data Input Registers 0–255 (SIU_GPDIn) | 7-40 |
| 7.3.1.16 | External IRQ Input Select Register (SIU_EIISR) | 7-41 |
| 7.3.1.17 | DSPI Input Select Register (SIU_DISR) | 7-43 |
| 7.3.1.18 | eQADC Command FIFO Trigger Source Select - IMUX Select Registers (SIU_ISEL[4-7]) | 7-46 |
| 7.3.1.19 | eTPU Input Select Register (SIU_ISEL 8) | 7-60 |
| 7.3.1.20 | eQADC Advance Trigger Selection (SIU_ISEL9) | 7-61 |
| 7.3.1.21 | Decimation Filter Register 1 (SIU_DECFIL1) | 7-62 |
| 7.3.1.22 | Decimation Filter Register 2 (SIU_DECFIL2) | 7-64 |
| 7.3.1.23 | Chip Configuration Register (SIU_CCR) | 7-66 |
| 7.3.1.24 | External Clock Control Register (SIU_ECCR) | 7-67 |
| 7.3.1.25 | Compare B Register High (SIU_CBRH) | 7-68 |
| 7.3.1.26 | Compare B Register Low (SIU_CBRL) | 7-69 |
| 7.3.1.27 | System Clock Register (SIU_SYSDIV) | 7-69 |
| 7.3.1.28 | Halt Register (SIU_HLT) | 7-70 |
| 7.3.1.29 | Halt Acknowledge Register (SIU_HLTACK) | 7-71 |
| 7.3.1.30 | Parallel GPIO Pin Data Output Register (SIU_PGPDO0 - SIU_PGPDO15) | 7-73 |
| 7.3.1.31 | Parallel GPIO Pin Data Input Register (SIU_PGPDIO - SIU_PGPDIO15) | 7-74 |
| 7.3.1.32 | Masked Parallel GPIO Pin Data Output Register (SIU_MPGPDO0 - SIU_MPGPDO31) | 7-75 |
| 7.3.1.33 | SIU DSPI Serialization Registers | 7-76 |
| 7.3.1.34 | Serialized Output Signal Selection Registers for DSPI_D | 7-84 |
| 7.3.1.35 | GPIO Pin Data Input Registers (SIU_GPDIO_3 - SIU_GPDIO508_511) - Standard | 7-86 |
| 7.4 | Functional Description | 7-87 |
| 7.4.1 | Pad Configuration | 7-87 |
| 7.4.2 | Reset Control | 7-88 |
| 7.4.2.1 | Reset Boot Configuration | 7-88 |
| 7.4.2.2 | RESET Pin Glitch Detect | 7-88 |
| 7.4.3 | External Interrupts | 7-88 |
| 7.4.4 | GPIO Operation | 7-91 |
| 7.4.5 | Internal Multiplexing | 7-91 |
| 7.4.5.1 | eQADC External Trigger Input Multiplexing | 7-92 |
| 7.4.5.2 | SIU External Interrupt Input Multiplexing | 7-93 |
| 7.4.5.3 | Multiplexed Inputs for DSPI Multiple Transfer Operation | 7-93 |

Chapter 8 System Information Module

| | | |
|-------|---------------|-----|
| 8.1 | SIM Overview | 8-1 |
| 8.1.1 | SIM Constants | 8-2 |

Chapter 9 Boot Assist Module (BAM)

| | | |
|-------|---------------------------|-----|
| 9.1 | Overview | 9-1 |
| 9.2 | Features | 9-1 |
| 9.3 | Modes of Operation | 9-1 |
| 9.3.1 | Normal Mode | 9-1 |
| 9.3.2 | Debug Mode | 9-2 |
| 9.3.3 | Internal Boot Mode | 9-2 |
| 9.3.4 | Serial Boot Mode | 9-2 |
| 9.3.5 | Development Bus Boot Mode | 9-2 |
| 9.4 | Memory Map | 9-2 |
| 9.5 | Functional Description | 9-3 |

| | | |
|---------|--|------|
| 9.5.1 | BAM Program Flow Chart | 9-3 |
| 9.5.2 | BAM Program Operation | 9-4 |
| 9.5.3 | Reset Configuration Half Word (RCHW) | 9-6 |
| 9.5.3.1 | Application Start Address Register | 9-8 |
| 9.5.4 | Internal Boot Mode | 9-8 |
| 9.5.5 | Serial Boot Mode | 9-8 |
| 9.5.5.1 | CAN Controller Configuration in the Fixed Baud Rate Mode | 9-10 |
| 9.5.5.2 | SCI Controller Configuration in Fixed Baud Rate Mode | 9-11 |
| 9.5.5.3 | Serial Boot Mode Download Protocol | 9-11 |
| 9.5.5.4 | Download Protocol Execution | 9-12 |
| 9.5.5.5 | Baud Rate Detection Procedure | 9-14 |
| 9.5.5.6 | CAN Baud Rate Detection | 9-14 |
| 9.5.6 | Booting from the Development Bus | 9-16 |
| 9.5.6.1 | EBI Configuration for Separate Address and Data Development Bus Boot Mode | 9-16 |
| 9.5.6.2 | EBI Configuration for multiplexed Address and Data Development Bus Boot Mode | 9-17 |
| 9.5.7 | Enabling Debug of a Censored Device | 9-17 |

Chapter 10

Interrupts and Interrupt Controller (INTC)

| | | |
|----------|---|-------|
| 10.1 | Introduction | 10-1 |
| 10.1.1 | Block Diagram | 10-1 |
| 10.1.2 | Overview | 10-2 |
| 10.1.3 | Features | 10-4 |
| 10.1.4 | Modes of Operation | 10-5 |
| 10.1.4.1 | Software Vector Mode | 10-5 |
| 10.1.4.2 | Hardware Vector Mode | 10-6 |
| 10.2 | External Signal Description | 10-7 |
| 10.3 | Memory Map and Register Definition | 10-7 |
| 10.3.1 | Register Descriptions | 10-9 |
| 10.3.1.1 | INTC Module Configuration Register (INTC_MCR) | 10-9 |
| 10.3.1.2 | INTC Current Priority Register (INTC_CPR) | 10-10 |
| 10.3.1.3 | INTC Interrupt Acknowledge Register (INTC_IACKR) | 10-10 |
| 10.3.1.4 | INTC End-of-Interrupt Register (INTC_EOIR) | 10-11 |
| 10.3.1.5 | INTC Software Set/Clear Interrupt Registers (INTC_SSCIR0–7) | 10-12 |
| 10.3.1.6 | INTC Priority Select Registers (INTC_PSR0–479) | 10-13 |
| 10.4 | Functional Description | 10-13 |
| 10.4.1 | Interrupt Request Sources | 10-13 |
| 10.4.1.1 | Peripheral Interrupt Requests | 10-31 |
| 10.4.1.2 | Software configurable Interrupt Requests | 10-31 |
| 10.4.1.3 | Unique Vector for Each Interrupt Request Source | 10-31 |
| 10.4.2 | Priority Management | 10-31 |
| 10.4.2.1 | Current Priority and Preemption | 10-32 |
| 10.4.2.2 | LIFO | 10-33 |
| 10.4.3 | Details on Handshaking with Processor | 10-33 |
| 10.4.3.1 | Software Vector Mode Handshaking | 10-33 |
| 10.4.3.2 | Hardware Vector Mode Handshaking | 10-34 |
| 10.5 | Initialization and Application Information | 10-35 |
| 10.5.1 | Initialization Flow | 10-35 |
| 10.5.2 | Interrupt Exception Handler | 10-36 |
| 10.5.2.1 | Software Vector Mode | 10-36 |
| 10.5.2.2 | Hardware Vector Mode | 10-37 |
| 10.5.3 | ISR, RTOS, and Task Hierarchy | 10-37 |
| 10.5.4 | Order of Execution | 10-38 |
| 10.5.5 | Priority Ceiling Protocol | 10-39 |
| 10.5.5.1 | Elevating Priority | 10-39 |
| 10.5.5.2 | Ensuring Coherency | 10-39 |
| 10.5.6 | Selecting Priorities According to Request Rates and Deadlines | 10-42 |
| 10.5.7 | Software configurable Interrupt Requests | 10-42 |
| 10.5.7.1 | Scheduling a Lower Priority Portion of an ISR | 10-42 |
| 10.5.7.2 | Scheduling an ISR on Another Processor | 10-43 |
| 10.5.8 | Lowering Priority Within an ISR | 10-43 |

| | | |
|----------|--|-------|
| 10.5.9 | Negating an Interrupt Request Outside of its ISR | 10-43 |
| 10.5.9.1 | Negating an Interrupt Request as a Side Effect of an ISR | 10-43 |
| 10.5.9.2 | Negating Multiple Interrupt Requests in One ISR | 10-44 |
| 10.5.9.3 | Proper Setting of Interrupt Request Priority | 10-44 |
| 10.5.10 | Examining LIFO contents | 10-44 |

Chapter 11 General-Purpose Static RAM (SRAM)

| | | |
|--------|--|------|
| 11.1 | Introduction | 11-1 |
| 11.2 | SRAM Operating Modes | 11-1 |
| 11.3 | External Signal Description | 11-1 |
| 11.4 | Register Memory Map | 11-2 |
| 11.5 | Functional Description | 11-2 |
| 11.6 | SRAM ECC Mechanism | 11-2 |
| 11.6.1 | Access Timing | 11-3 |
| 11.6.2 | Reset Effects on SRAM Accesses | 11-4 |
| 11.7 | Initialization and Application Information | 11-4 |
| 11.7.1 | Example Code | 11-5 |

Chapter 12 Flash Memory Array and Control

| | | |
|-----------|--|-------|
| 12.1 | Introduction | 12-1 |
| 12.1.1 | Block Diagram | 12-2 |
| 12.1.1.1 | Flash Memory Module | 12-2 |
| 12.1.2 | Features | 12-3 |
| 12.1.3 | Modes of Operation | 12-4 |
| 12.1.3.1 | Flash User Mode | 12-4 |
| 12.1.3.2 | User Test Mode | 12-4 |
| 12.2 | Memory Map and Registers | 12-4 |
| 12.2.1 | Module Memory Map | 12-4 |
| 12.2.2 | Register Descriptions | 12-7 |
| 12.2.2.1 | Module Configuration Register (FLASH_x_MCR) | 12-8 |
| 12.2.2.2 | Low/Mid Address Space Block Locking Register (FLASH_x_LMLR) | 12-12 |
| 12.2.2.3 | High Address Space Block Locking Register (FLASH_x_HLR) | 12-14 |
| 12.2.2.4 | Secondary Low/Mid Address Space Block Locking Register (FLASH_x_SLMLR) | 12-16 |
| 12.2.2.5 | Low/Mid Address Space Block Select Register (FLASH_x_LMSR) | 12-17 |
| 12.2.2.6 | High Address Space Block Select Register (FLASH_x_HSR) | 12-18 |
| 12.2.2.7 | Address Register (FLASH_x_AR) | 12-18 |
| 12.2.2.8 | Flash Bus Interface Configuration Register (FLASH_BIUCR) | 12-19 |
| 12.2.2.9 | Flash Bus Interface Access Protection Register (FLASH_BIUAPR) | 12-22 |
| 12.2.2.10 | Flash Bus Interface Configuration Register 2 (FLASH_BIUCR2) | 12-23 |
| 12.2.2.11 | User Test Register 0 (FLASH_x_UT0) | 12-24 |
| 12.2.2.12 | User Test Register 1 (FLASH_x_UT1) | 12-27 |
| 12.2.2.13 | User Test Register 2 (FLASH_x_UT2) | 12-27 |
| 12.3 | Functional Description | 12-28 |
| 12.3.1 | Flash User Mode | 12-28 |
| 12.3.2 | Flash Read and Write | 12-28 |
| 12.3.3 | Read While Write (RWW) | 12-28 |
| 12.3.4 | Flash Programming | 12-29 |
| 12.3.4.1 | Software Locking | 12-32 |
| 12.3.5 | Flash Erase | 12-32 |
| 12.3.5.1 | Flash Erase Suspend/Resume | 12-33 |
| 12.3.6 | Flash Shadow Block | 12-35 |
| 12.3.7 | Flash Reset | 12-36 |

Chapter 13 Core (e200z7) Overview

| | | |
|------|----------|------|
| 13.1 | Overview | 13-1 |
|------|----------|------|

| | | |
|----------|---|-------|
| 13.2 | Register Model | 13-1 |
| 13.3 | Cache | 13-4 |
| 13.3.1 | Cache Overview | 13-4 |
| 13.3.2 | Cache Registers | 13-5 |
| 13.3.2.1 | L1 Cache Control and Status Register 0 (L1CSR0) | 13-5 |
| 13.3.2.2 | L1 Cache Control and Status Register 1 (L1CSR1) | 13-8 |
| 13.3.2.3 | L1FINV0 | 13-10 |
| 13.3.2.4 | L1FINV1 | 13-11 |
| 13.4 | MMU | 13-11 |
| 13.4.1 | Overview | 13-12 |
| 13.4.2 | MMU Instructions | 13-12 |
| 13.4.3 | TLB Read Entry Instruction (tlbre) | 13-12 |
| 13.4.4 | TLB Write Entry Instruction (tlbwe) | 13-13 |
| 13.4.5 | MMU Registers | 13-14 |
| 13.4.5.1 | DEAR Register | 13-14 |
| 13.4.5.2 | MMU Control and Status Register 0 (MMUCSR0) | 13-14 |
| 13.4.5.3 | MMU Assist Registers (MAS) | 13-15 |
| 13.5 | Exceptions | 13-20 |
| 13.5.1 | Exception Syndrome Register | 13-21 |
| 13.6 | Machine State Register | 13-22 |
| 13.6.1 | Machine Check Syndrome Register (MCSR) | 13-24 |
| 13.7 | Interrupt Vector Prefix Registers (IVPR) | 13-27 |
| 13.8 | Interrupt Vector Offset Registers (IVORxx) | 13-27 |
| 13.9 | Interrupt Definitions | 13-28 |
| 13.9.1 | Critical Input Interrupt (IVOR0) | 13-28 |
| 13.9.2 | Machine Check Interrupt (IVOR1) | 13-29 |
| 13.9.2.1 | Machine Check Causes | 13-29 |
| 13.9.2.2 | Machine Check Interrupt Actions | 13-29 |
| 13.9.3 | Data Storage Interrupt (IVOR2) | 13-30 |
| 13.9.4 | Instruction Storage Interrupt (IVOR3) | 13-31 |
| 13.9.5 | External Input Interrupt (IVOR4) | 13-31 |
| 13.9.6 | Alignment Interrupt (IVOR5) | 13-32 |
| 13.9.7 | Program Interrupt (IVOR6) | 13-33 |
| 13.9.8 | Floating-Point Unavailable Interrupt (IVOR7) | 13-34 |
| 13.9.9 | System Call Interrupt (IVOR8) | 13-34 |
| 13.9.10 | Auxiliary Processor Unavailable Interrupt (IVOR9) | 13-35 |
| 13.9.11 | Decrementer Interrupt (IVOR10) | 13-35 |
| 13.9.12 | Fixed-Interval Timer Interrupt (IVOR11) | 13-35 |
| 13.9.13 | Watchdog Timer Interrupt (IVOR12) | 13-36 |
| 13.9.14 | Data TLB Error Interrupt (IVOR13) | 13-37 |
| 13.9.15 | Instruction TLB Error Interrupt (IVOR14) | 13-37 |
| 13.9.16 | Debug Interrupt (IVOR15) | 13-38 |
| 13.9.17 | SPE/EFPU APU Unavailable Interrupt (IVOR32) | 13-39 |
| 13.9.18 | Embedded Floating-point Data Interrupt (IVOR33) | 13-40 |
| 13.9.19 | Embedded Floating-point Round Interrupt (IVOR34) | 13-41 |
| 13.9.20 | Performance Monitor Interrupt (IVOR35) | 13-41 |
| 13.10 | Special Features | 13-42 |
| 13.10.1 | WAIT APU | 13-42 |
| 13.10.2 | Volatile Context Save/Restore APU | 13-43 |
| 13.10.3 | Performance Monitor | 13-43 |

Chapter 14

AMBA Crossbar Switch (XBAR)

| | | |
|----------|------------------------------------|------|
| 14.1 | Introduction | 14-1 |
| 14.1.1 | Overview | 14-1 |
| 14.1.2 | Block Diagram | 14-2 |
| 14.1.3 | Features | 14-2 |
| 14.1.4 | Modes of Operation | 14-3 |
| 14.1.4.1 | Normal Mode | 14-3 |
| 14.1.4.2 | Debug Mode | 14-3 |
| 14.2 | Memory Map and Register Definition | 14-3 |
| 14.2.1 | Register Descriptions | 14-4 |

| | | |
|----------|---|-------|
| 14.2.1.1 | Master Priority Registers (XBAR_MPRn) | 14-4 |
| 14.2.1.2 | Slave General-Purpose Control Registers (XBAR_SGPCRn) | 14-6 |
| 14.3 | Functional Description | 14-9 |
| 14.3.1 | Overview | 14-9 |
| 14.3.2 | General Operation | 14-9 |
| 14.3.3 | Master Ports | 14-10 |
| 14.3.4 | Slave Ports | 14-10 |
| 14.3.5 | Priority Assignment | 14-10 |
| 14.3.6 | Arbitration | 14-10 |
| 14.3.6.1 | Fixed Priority Operation | 14-11 |
| 14.3.6.2 | Round-Robin Priority Operation | 14-11 |

Chapter 15 Peripheral Bridge (PBRIDGE)

| | | |
|----------|---|-------|
| 15.1 | Introduction | 15-1 |
| 15.1.1 | Block Diagram | 15-1 |
| 15.1.2 | Access Protections | 15-1 |
| 15.1.3 | Features | 15-3 |
| 15.1.4 | Modes of Operation | 15-4 |
| 15.2 | External Signal Description | 15-4 |
| 15.3 | Memory Map and Register Definitions | 15-4 |
| 15.3.1 | Register Descriptions | 15-6 |
| 15.3.1.1 | Master Privilege Control Register (PBRIDGE_x_MPCR) | 15-6 |
| 15.3.1.2 | Peripheral Access Control Registers (PBRIDGE_x_PACR) and Off-Platform Peripheral Access Control Registers (PBRIDGE_x_OPACR) | 15-7 |
| 15.4 | Functional Description | 15-13 |
| 15.4.1 | Access Support | 15-13 |
| 15.4.2 | Peripheral Write Buffering | 15-13 |
| 15.4.2.1 | Read Cycles | 15-14 |
| 15.4.2.2 | Write Cycles | 15-14 |
| 15.4.2.3 | Buffered Write Cycles | 15-14 |
| 15.4.3 | General Operation | 15-14 |

Chapter 16 Memory Protection Unit (MPU)

| | | |
|----------|--|-------|
| 16.1 | Introduction | 16-1 |
| 16.1.1 | Block Diagram | 16-2 |
| 16.1.2 | Features | 16-3 |
| 16.2 | Memory Map and Registers | 16-4 |
| 16.2.1 | Module Memory Map | 16-4 |
| 16.2.2 | Register Descriptions | 16-6 |
| 16.2.2.1 | MPU Control/Error Status Register (MPU_CESR) | 16-6 |
| 16.2.2.2 | MPU Error Address Register, MPU Port 0 to 3 (MPU_EAR n) | 16-7 |
| 16.2.2.3 | MPU Error Detail Register, MPU Port 0 to 3 (MPU_EDR n) | 16-7 |
| 16.2.2.4 | MPU Region Descriptor n (MPU_RGD n) | 16-8 |
| 16.2.2.5 | MPU Region Descriptor Alternate Access Control n (MPU_RGDAAC n) | 16-13 |
| 16.3 | Functional Description | 16-14 |
| 16.3.1 | Access Evaluation | 16-14 |
| 16.3.1.1 | Access Evaluation—Hit Determination | 16-14 |
| 16.3.1.2 | Access Evaluation—Privilege Violation Determination | 16-14 |
| 16.3.2 | AHB Error Terminations | 16-15 |
| 16.4 | Initialization Information | 16-15 |
| 16.5 | Application Information | 16-15 |

Chapter 17 Error Correction Status Module (ECSM)

| | | |
|--------|--------------|------|
| 17.1 | Introduction | 17-1 |
| 17.1.1 | Features | 17-1 |

| | | |
|-----------|---|-------|
| 17.2 | Memory Map and Registers | 17-2 |
| 17.2.1 | Module Memory Map | 17-2 |
| 17.2.2 | Register Descriptions | 17-3 |
| 17.2.2.1 | Processor Core Type (ECSM_PCT) | 17-4 |
| 17.2.2.2 | Revision (ECSM_REV) | 17-4 |
| 17.2.2.3 | Peripheral Module Configuration (ECSM_IMC) | 17-4 |
| 17.2.2.4 | Miscellaneous Reset Status Register (ECSM_MRSR) | 17-4 |
| 17.2.2.5 | ECC Configuration Register (ECSM_ECR) | 17-5 |
| 17.2.2.6 | ECC Status Register (ECSM_ESR) | 17-6 |
| 17.2.2.7 | ECC Error Generation Register (ECSM_EEGR) | 17-7 |
| 17.2.2.8 | Flash ECC Address Register (ECSM_FEAR) | 17-9 |
| 17.2.2.9 | Flash ECC Master Number Register (ECSM_FEMR) | 17-10 |
| 17.2.2.10 | Flash ECC Attributes Register (ECSM_FEAT) | 17-11 |
| 17.2.2.11 | Flash ECC Data Register (ECSM_FEDR) | 17-11 |
| 17.2.2.12 | RAM ECC Address Register (ECSM_REAR) | 17-12 |
| 17.2.2.13 | RAM ECC Syndrome Register (ECSM_RESR) | 17-13 |
| 17.2.2.14 | RAM ECC Master Number Register (ECSM_REMR) | 17-15 |
| 17.2.2.15 | RAM ECC Attributes Register (ECSM_REAT) | 17-15 |
| 17.2.2.16 | RAM ECC Data Register (ECSM_REDR) | 17-16 |

Chapter 18

Software Watchdog Timer (SWT)

| | | |
|----------|--------------------------------------|------|
| 18.1 | Introduction | 18-1 |
| 18.1.1 | Overview | 18-1 |
| 18.1.2 | Features | 18-1 |
| 18.1.3 | Modes of Operation | 18-1 |
| 18.2 | External Signal Description | 18-2 |
| 18.3 | Memory Map and Register Definition | 18-2 |
| 18.3.1 | Memory Map | 18-2 |
| 18.3.2 | Register Descriptions | 18-2 |
| 18.3.2.1 | SWT Control Register (SWT_MCR) | 18-2 |
| 18.3.2.2 | SWT Interrupt Register (SWT_IR) | 18-5 |
| 18.3.2.3 | SWT Time-Out Register (SWT_TO) | 18-5 |
| 18.3.2.4 | SWT Window Register (SWT_WN) | 18-6 |
| 18.3.2.5 | SWT Service Register (SWT_SR) | 18-6 |
| 18.3.2.6 | SWT Counter Output Register (SWT_CO) | 18-7 |
| 18.3.2.7 | SWT Service Key Register (SWT_SK) | 18-8 |
| 18.4 | Functional Description | 18-9 |

Chapter 19

System Timer Module (STM)

| | | |
|----------|---|------|
| 19.1 | Introduction | 19-1 |
| 19.1.1 | Overview | 19-1 |
| 19.1.2 | Features | 19-1 |
| 19.1.3 | Modes of Operation | 19-1 |
| 19.2 | External Signal Description | 19-1 |
| 19.3 | Memory Map and Register Definition | 19-1 |
| 19.3.1 | Memory Map | 19-2 |
| 19.3.2 | Register Descriptions | 19-3 |
| 19.3.2.1 | STM Control Register (STM_CR) | 19-3 |
| 19.3.2.2 | STM Count Register (STM_CNT) | 19-4 |
| 19.3.2.3 | STM Channel Control Register (STM_CCRn) | 19-4 |
| 19.3.2.4 | STM Channel Interrupt Register (STM_CIRn) | 19-5 |
| 19.3.2.5 | STM Channel Compare Register (STM_CMPn) | 19-5 |
| 19.4 | Functional Description | 19-6 |

Chapter 20

Periodic Interrupt Timer (PIT_RTI)

| | | |
|----------|---|-------|
| 20.1 | Introduction | 20-1 |
| 20.1.1 | Overview | 20-1 |
| 20.1.2 | Block Diagram | 20-2 |
| 20.1.3 | Features | 20-2 |
| 20.2 | Signal Description | 20-3 |
| 20.3 | Memory Map and Register Description | 20-3 |
| 20.3.1 | Memory Map | 20-3 |
| 20.3.2 | Register Descriptions | 20-4 |
| 20.3.2.1 | PIT Module Control Register (PIT_MCR) | 20-4 |
| 20.3.2.2 | Timer Load Value Register (PIT_RTI_LDVAL, PIT_CHn_LDVAL) | 20-5 |
| 20.3.2.3 | Current Timer Value Register (PIT_RTI_CVAL, PIT_CHn_CVAL) | 20-5 |
| 20.3.2.4 | Timer Control Register (PIT_RTI_TCTRL, PIT_CHn_TCTRL) | 20-5 |
| 20.3.2.5 | Timer Flag Register (PIT_RTI_TFLG, PIT_CHn_TFLG) | 20-6 |
| 20.4 | Functional Description | 20-7 |
| 20.4.1 | General | 20-7 |
| 20.4.1.1 | Timers | 20-7 |
| 20.4.1.2 | Debug Mode | 20-8 |
| 20.4.2 | Interrupts | 20-9 |
| 20.5 | Initialization and Application Information | 20-9 |
| 20.5.1 | Example Configuration | 20-9 |
| 20.5.2 | Low Power Mode – Using the RTI for System Wakeup | 20-9 |
| 20.5.2.1 | Low Power Mode Without RTI Wakeup | 20-10 |
| 20.5.2.2 | Low Power Mode With RTI Wakeup | 20-10 |

Chapter 21

Enhanced Direct Memory Access Controller (eDMA)

| | | |
|-----------|--|-------|
| 21.1 | Introduction | 21-1 |
| 21.1.1 | Block Diagram | 21-2 |
| 21.1.2 | Features | 21-2 |
| 21.1.3 | Modes of Operation | 21-3 |
| 21.1.3.1 | Normal Mode | 21-3 |
| 21.1.3.2 | Debug Mode | 21-3 |
| 21.2 | External Signal Description | 21-3 |
| 21.3 | Memory Map and Registers | 21-4 |
| 21.3.1 | Module Memory Map | 21-4 |
| 21.3.2 | Register Descriptions | 21-13 |
| 21.3.2.1 | eDMA Control Register (EDMA_x_MCR) | 21-13 |
| 21.3.2.2 | eDMA Error Status Register (EDMA_x_ESR) | 21-17 |
| 21.3.2.3 | eDMA Enable Request Registers (EDMA_A_ERQRH, EDMA_x_ERQRL) | 21-19 |
| 21.3.2.4 | eDMA Enable Error Interrupt Registers (EDMA_A_EEIRH, EDMA_x_EEIRL) | 21-21 |
| 21.3.2.5 | eDMA Set Enable Request Register (EDMA_x_SERQR) | 21-23 |
| 21.3.2.6 | eDMA Clear Enable Request Register (EDMA_x_CERQR) | 21-24 |
| 21.3.2.7 | eDMA Set Enable Error Interrupt Register (EDMA_x_SEEIR) | 21-25 |
| 21.3.2.8 | eDMA Clear Enable Error Interrupt Register (EDMA_x_CEEIR) | 21-26 |
| 21.3.2.9 | eDMA Clear Interrupt Request Register (EDMA_x_CIRQR) | 21-27 |
| 21.3.2.10 | eDMA Clear Error Register (EDMA_x_CER) | 21-27 |
| 21.3.2.11 | eDMA Set START Bit Register (EDMA_x_SSBR) | 21-28 |
| 21.3.2.12 | eDMA Clear DONE Status Bit Register (EDMA_x_CDSBR) | 21-29 |
| 21.3.2.13 | eDMA Interrupt Request Registers (EDMA_A_IRQRH, EDMA_x_IRQRL) | 21-30 |
| 21.3.2.14 | eDMA Error Registers (EDMA_x_ERH, EDMA_x_ERL) | 21-31 |
| 21.3.2.15 | DMA Hardware Request Status (EDMA_A_HRSH, EDMA_x_HRSL) | 21-32 |
| 21.3.2.16 | eDMA Global Write Registers (EDMA_x_GWRH and EDMA_x_GWRL) | 21-33 |
| 21.3.2.17 | eDMA Channel <i>n</i> Priority Registers (EDMA_x_CPR <i>n</i>) | 21-33 |
| 21.3.2.18 | Transfer Control Descriptor (TCD) | 21-34 |
| 21.4 | Functional Description | 21-40 |
| 21.4.1 | eDMA Basic Data Flow | 21-42 |
| 21.5 | Initialization / Application Information | 21-44 |
| 21.5.1 | eDMA Initialization | 21-44 |

| | |
|---|-------|
| 21.5.2 DMA Programming Errors | 21-47 |
| 21.5.3 DMA Request Assignments | 21-48 |
| 21.5.4 DMA Arbitration Mode Considerations | 21-52 |
| 21.5.4.1 Fixed-Group Arbitration, Fixed-Channel Arbitration | 21-52 |
| 21.5.4.2 Round-Robin Group Arbitration, Fixed-Channel Arbitration | 21-52 |
| 21.5.4.3 Round-Robin Group Arbitration, Round-Robin Channel Arbitration | 21-52 |
| 21.5.4.4 Fixed-Group Arbitration, Round-Robin Channel Arbitration | 21-53 |
| 21.5.5 DMA Transfer | 21-53 |
| 21.5.5.1 Single Request | 21-53 |
| 21.5.5.2 Multiple Requests | 21-54 |
| 21.5.5.3 Modulo Feature | 21-56 |
| 21.5.6 TCD Status | 21-56 |
| 21.5.6.1 Minor Loop Complete | 21-56 |
| 21.5.6.2 Active Channel TCD Reads | 21-57 |
| 21.5.6.3 Preemption Status | 21-57 |
| 21.5.7 Channel Linking | 21-58 |
| 21.5.8 Dynamic Programming | 21-59 |
| 21.5.8.1 Dynamic Channel Linking and Dynamic Scatter-Gather Operation | 21-59 |

Chapter 22 FlexRay Communication Controller (FLEXRAY)

| | |
|---|-------|
| 22.1 Introduction | 22-1 |
| 22.1.1 Reference | 22-1 |
| 22.1.2 Glossary | 22-1 |
| 22.1.3 Color Coding | 22-2 |
| 22.1.4 Overview | 22-2 |
| 22.1.5 Features | 22-4 |
| 22.1.6 Modes of Operation | 22-5 |
| 22.1.6.1 Disabled Mode | 22-5 |
| 22.1.6.2 Normal Mode | 22-5 |
| 22.2 External Signal Description | 22-6 |
| 22.2.1 Detailed Signal Descriptions | 22-6 |
| 22.2.1.1 FR_A_RX — Receive Data Channel A | 22-6 |
| 22.2.1.2 FR_A_TX — Transmit Data Channel A | 22-6 |
| 22.2.1.3 FR_A_TX_EN — Transmit Enable Channel A | 22-7 |
| 22.2.1.4 FR_B_RX — Receive Data Channel B | 22-7 |
| 22.2.1.5 FR_B_TX — Transmit Data Channel B | 22-7 |
| 22.2.1.6 FR_B_TX_EN — Transmit Enable Channel B | 22-7 |
| 22.2.1.7 FR_DBG[3], FR_DBG[2], FR_DBG[1], FR_DBG[0] — Strobe Signals | 22-7 |
| 22.3 Controller Host Interface Clocking | 22-7 |
| 22.4 Protocol Engine Clocking | 22-7 |
| 22.4.1 Oscillator Clocking | 22-7 |
| 22.4.2 PLL Clocking | 22-8 |
| 22.5 Memory Map and Register Description | 22-8 |
| 22.5.1 Memory Map | 22-8 |
| 22.5.2 Register Descriptions | 22-11 |
| 22.5.2.1 Register Reset | 22-11 |
| 22.5.2.2 Register Write Access | 22-12 |
| 22.5.2.3 Module Version Register (MVR) | 22-13 |
| 22.5.2.4 Module Configuration Register (MCR) | 22-13 |
| 22.5.2.5 System Memory Base Address Register (SYMBADR) | 22-15 |
| 22.5.2.6 Strobe Signal Control Register (STBSCR) | 22-16 |
| 22.5.2.7 Message Buffer Data Size Register (MBDSR) | 22-17 |
| 22.5.2.8 Message Buffer Segment Size and Utilization Register (MBSSUTR) | 22-18 |
| 22.5.2.9 Protocol Operation Control Register (POCR) | 22-18 |
| 22.5.2.10 Global Interrupt Flag and Enable Register (GIFER) | 22-20 |
| 22.5.2.11 Protocol Interrupt Flag Register 0 (PIFR0) | 22-22 |
| 22.5.2.12 Protocol Interrupt Flag Register 1 (PIFR1) | 22-24 |
| 22.5.2.13 Protocol Interrupt Enable Register 0 (PIER0) | 22-25 |
| 22.5.2.14 Protocol Interrupt Enable Register 1 (PIER1) | 22-26 |
| 22.5.2.15 CHI Error Flag Register (CHIERFR) | 22-27 |
| 22.5.2.16 Message Buffer Interrupt Vector Register (MBIVEC) | 22-29 |
| 22.5.2.17 Channel A Status Error Counter Register (CASERCR) | 22-30 |

| | | |
|-----------|--|-------|
| 22.5.2.18 | Channel B Status Error Counter Register (CBSERCR) | 22-30 |
| 22.5.2.19 | Protocol Status Register 0 (PSR0) | 22-31 |
| 22.5.2.20 | Protocol Status Register 1 (PSR1) | 22-32 |
| 22.5.2.21 | Protocol Status Register 2 (PSR2) | 22-33 |
| 22.5.2.22 | Protocol Status Register 3 (PSR3) | 22-35 |
| 22.5.2.23 | Macrotick Counter Register (MTCTR) | 22-36 |
| 22.5.2.24 | Cycle Counter Register (CYCTR) | 22-37 |
| 22.5.2.25 | Slot Counter Channel A Register (SLTCTAR) | 22-37 |
| 22.5.2.26 | Slot Counter Channel B Register (SLTCTBR) | 22-38 |
| 22.5.2.27 | Rate Correction Value Register (RTCORVR) | 22-38 |
| 22.5.2.28 | Offset Correction Value Register (OFCORVR) | 22-39 |
| 22.5.2.29 | Combined Interrupt Flag Register (CIFRR) | 22-39 |
| 22.5.2.30 | System Memory Access Time-Out Register (SYMATOR) | 22-40 |
| 22.5.2.31 | Sync Frame Counter Register (SFCNTR) | 22-41 |
| 22.5.2.32 | Sync Frame Table Offset Register (SFTOR) | 22-41 |
| 22.5.2.33 | Sync Frame Table Configuration, Control, Status Register (SFTCCSR) | 22-42 |
| 22.5.2.34 | Sync Frame ID Rejection Filter Register (SFIDRFR) | 22-43 |
| 22.5.2.35 | Sync Frame ID Acceptance Filter Value Register (SFIDAFVR) | 22-44 |
| 22.5.2.36 | Sync Frame ID Acceptance Filter Mask Register (SFIDAFMR) | 22-44 |
| 22.5.2.37 | Network Management Vector Registers (NMVR0–NMVR5) | 22-44 |
| 22.5.2.38 | Network Management Vector Length Register (NMVLR) | 22-45 |
| 22.5.2.39 | Timer Configuration and Control Register (TICCR) | 22-46 |
| 22.5.2.40 | Timer 1 Cycle Set Register (TI1CYSR) | 22-47 |
| 22.5.2.41 | Timer 1 Macrotick Offset Register (TI1MTOR) | 22-47 |
| 22.5.2.42 | Timer 2 Configuration Register 0 (TI2CR0) | 22-48 |
| 22.5.2.43 | Timer 2 Configuration Register 1 (TI2CR1) | 22-48 |
| 22.5.2.44 | Slot Status Selection Register (SSSR) | 22-49 |
| 22.5.2.45 | Slot Status Counter Condition Register (SSCCR) | 22-50 |
| 22.5.2.46 | Slot Status Registers (SSR0–SSR7) | 22-52 |
| 22.5.2.47 | Slot Status Counter Registers (SSCR0–SSCR3) | 22-53 |
| 22.5.2.48 | MTS A Configuration Register (MTSACFR) | 22-54 |
| 22.5.2.49 | MTS B Configuration Register (MTSBCFR) | 22-54 |
| 22.5.2.50 | Receive Shadow Buffer Index Register (RSBIR) | 22-55 |
| 22.5.2.51 | Receive FIFO System Memory Base Address Register (RFSYMBADR) | 22-55 |
| 22.5.2.52 | Receive FIFO Periodic Timer Register (RFPTR) | 22-56 |
| 22.5.2.53 | Receive FIFO Watermark and Selection Register (RFWMSR) | 22-57 |
| 22.5.2.54 | Receive FIFO Start Index Register (RFSIR) | 22-57 |
| 22.5.2.55 | Receive FIFO Depth and Size Register (RFDSR) | 22-58 |
| 22.5.2.56 | Receive FIFO A Read Index Register (RFARIR) | 22-58 |
| 22.5.2.57 | Receive FIFO B Read Index Register (RFBIRIR) | 22-59 |
| 22.5.2.58 | Receive FIFO Fill Level and POP Count Register (RFFLPCR) | 22-59 |
| 22.5.2.59 | Receive FIFO Message ID Acceptance Filter Value Register (RFMIDAFVR) | 22-60 |
| 22.5.2.60 | Receive FIFO Message ID Acceptance Filter Mask Register (RFMIAFMR) | 22-60 |
| 22.5.2.61 | Receive FIFO Frame ID Rejection Filter Value Register (RFFIDRFVR) | 22-61 |
| 22.5.2.62 | Receive FIFO Frame ID Rejection Filter Mask Register (RFFIDRFMR) | 22-61 |
| 22.5.2.63 | Receive FIFO Range Filter Configuration Register (RFRFCFR) | 22-61 |
| 22.5.2.64 | Receive FIFO Range Filter Control Register (RFRFCTR) | 22-62 |
| 22.5.2.65 | Last Dynamic Transmit Slot Channel A Register (LDTXSLAR) | 22-63 |
| 22.5.2.66 | Last Dynamic Transmit Slot Channel B Register (LDTXSLBR) | 22-63 |
| 22.5.2.67 | Protocol Configuration Registers | 22-64 |
| 22.5.2.68 | Message Buffer Configuration, Control, Status Registers (MBCCSRn) | 22-72 |
| 22.5.2.69 | Message Buffer Cycle Counter Filter Registers (MBCCFRn) | 22-74 |
| 22.5.2.70 | Message Buffer Frame ID Registers (MBFIDRn) | 22-75 |
| 22.5.2.71 | Message Buffer Index Registers (MBIDXRn) | 22-75 |
| 22.6 | Functional Description | 22-76 |
| 22.6.1 | Message Buffer Concept | 22-76 |
| 22.6.2 | Physical Message Buffer | 22-76 |
| 22.6.2.1 | Message Buffer Header Field | 22-76 |
| 22.6.2.2 | Message Buffer Data Field | 22-77 |
| 22.6.3 | Message Buffer Types | 22-77 |
| 22.6.3.1 | Individual Message Buffers | 22-77 |
| 22.6.3.2 | Receive Shadow Buffers | 22-79 |
| 22.6.3.3 | Receive FIFO | 22-79 |

| | | |
|-----------|---|--------|
| 22.6.3.4 | Message Buffer Configuration and Control Data | 22-81 |
| 22.6.3.5 | Individual Message Buffer Control Data | 22-82 |
| 22.6.3.6 | Receive Shadow Buffer Configuration Data | 22-82 |
| 22.6.3.7 | Receive FIFO Control and Configuration Data | 22-82 |
| 22.6.4 | FlexRay Memory Layout | 22-83 |
| 22.6.4.1 | FlexRay Memory Layout (MCR[FAM] = 0) | 22-83 |
| 22.6.4.2 | FlexRay Memory Layout (MCR[FAM] = 1) | 22-84 |
| 22.6.4.3 | Message Buffer Header Area (MCR[FAM] = 0) | 22-85 |
| 22.6.4.4 | Message Buffer Header Area (MCR[FAM] = 1) | 22-86 |
| 22.6.4.5 | FIFO Message Buffer Header Area (MCR[FAM] = 1) | 22-86 |
| 22.6.4.6 | Message Buffer Data Area | 22-86 |
| 22.6.4.7 | Sync Frame Table Area | 22-86 |
| 22.6.5 | Physical Message Buffer Description | 22-86 |
| 22.6.5.1 | Message Buffer Protection and Data Consistency | 22-86 |
| 22.6.5.2 | Message Buffer Header Field Description | 22-87 |
| 22.6.5.3 | Message Buffer Data Field Description | 22-94 |
| 22.6.6 | Individual Message Buffer Functional Description | 22-95 |
| 22.6.6.1 | Individual Message Buffer Configuration | 22-96 |
| 22.6.6.2 | Single Transmit Message Buffers | 22-97 |
| 22.6.6.3 | Receive Message Buffers | 22-105 |
| 22.6.6.4 | Double Transmit Message Buffer | 22-111 |
| 22.6.7 | Individual Message Buffer Search | 22-120 |
| 22.6.7.1 | Message Buffer Cycle Counter Filtering | 22-121 |
| 22.6.7.2 | Message Buffer Channel Assignment Consistency | 22-122 |
| 22.6.7.3 | Node Related Slot Multiplexing | 22-122 |
| 22.6.7.4 | Message Buffer Search Error | 22-122 |
| 22.6.8 | Individual Message Buffer Reconfiguration | 22-122 |
| 22.6.8.1 | Reconfiguration Schemes | 22-123 |
| 22.6.9 | Receive FIFOs | 22-123 |
| 22.6.9.1 | Overview | 22-124 |
| 22.6.9.2 | FIFO Configuration | 22-124 |
| 22.6.9.3 | FIFO Periodic Timer | 22-125 |
| 22.6.9.4 | FIFO Reception | 22-125 |
| 22.6.9.5 | FIFO Almost-Full Interrupt Generation | 22-125 |
| 22.6.9.6 | FIFO Overflow Error Generation | 22-125 |
| 22.6.9.7 | FIFO Message Access | 22-125 |
| 22.6.9.8 | FIFO Update | 22-126 |
| 22.6.9.9 | FIFO Filtering | 22-126 |
| 22.6.10 | Channel Device Modes | 22-129 |
| 22.6.10.1 | Dual Channel Device Mode | 22-129 |
| 22.6.10.2 | Single Channel Device Mode | 22-130 |
| 22.6.11 | External Clock Synchronization | 22-131 |
| 22.6.12 | Sync Frame ID and Sync Frame Deviation Tables | 22-132 |
| 22.6.12.1 | Sync Frame ID Table Content | 22-133 |
| 22.6.12.2 | Sync Frame Deviation Table Content | 22-133 |
| 22.6.12.3 | Sync Frame ID and Sync Frame Deviation Table Setup | 22-133 |
| 22.6.12.4 | Sync Frame ID and Sync Frame Deviation Table Generation | 22-134 |
| 22.6.12.5 | Sync Frame Table Access | 22-135 |
| 22.6.13 | MTS Generation | 22-135 |
| 22.6.14 | Key Slot Transmission | 22-136 |
| 22.6.14.1 | Key Slot Assignment | 22-136 |
| 22.6.14.2 | Key Slot Transmission in POC:startup | 22-136 |
| 22.6.14.3 | Key Slot Transmission in POC:normal active | 22-136 |
| 22.6.15 | Sync Frame Filtering | 22-136 |
| 22.6.15.1 | Sync Frame Acceptance Filtering | 22-137 |
| 22.6.15.2 | Sync Frame Rejection Filtering | 22-137 |
| 22.6.16 | Strobe Signal Support | 22-137 |
| 22.6.16.1 | Strobe Signal Assignment | 22-137 |
| 22.6.16.2 | Strobe Signal Timing | 22-138 |
| 22.6.17 | Timer Support | 22-138 |
| 22.6.17.1 | Absolute Timer T1 | 22-139 |
| 22.6.17.2 | Absolute / Relative Timer T2 | 22-139 |
| 22.6.18 | Slot Status Monitoring | 22-140 |

| | |
|---|--------|
| 22.6.18.1 Channel Status Error Counter Registers | 22-141 |
| 22.6.18.2 Protocol Status Registers | 22-142 |
| 22.6.18.3 Slot Status Registers | 22-142 |
| 22.6.18.4 Slot Status Counter Registers | 22-142 |
| 22.6.18.5 Message Buffer Slot Status Field | 22-143 |
| 22.6.19 System Bus Access | 22-143 |
| 22.6.19.1 System Bus Illegal Address Access | 22-144 |
| 22.6.19.2 System Bus Access Timeout | 22-144 |
| 22.6.19.3 Continue after System Bus Failure | 22-144 |
| 22.6.19.4 Freeze after System Bus Failure | 22-144 |
| 22.6.20 Interrupt Support | 22-144 |
| 22.6.20.1 Individual Interrupt Sources | 22-144 |
| 22.6.20.2 Combined Interrupt Sources | 22-145 |
| 22.6.21 Lower Bit Rate Support | 22-148 |
| 22.7 Application Information | 22-149 |
| 22.7.1 Initialization Sequence | 22-149 |
| 22.7.1.1 Module Initialization | 22-149 |
| 22.7.1.2 Protocol Initialization | 22-150 |
| 22.7.2 Shut Down Sequence | 22-150 |
| 22.7.3 Number of Usable Message Buffers | 22-150 |
| 22.7.4 Protocol Control Command Execution | 22-151 |
| 22.7.5 Message Buffer Search on Simple Message Buffer Configuration | 22-152 |
| 22.7.5.1 Simple Message Buffer Configuration | 22-152 |
| 22.7.5.2 Behavior in static segment | 22-154 |
| 22.7.5.3 Behavior in dynamic segment | 22-154 |

Chapter 23

Enhanced Modular Input/Output Subsystem (eMIOS200)

| | |
|--|-------|
| 23.1 Introduction | 23-1 |
| 23.1.1 Block Diagram | 23-2 |
| 23.1.2 Features | 23-3 |
| 23.1.3 Modes of Operation | 23-3 |
| 23.1.4 eMIOS200 Channel Configurations | 23-3 |
| 23.2 External Signal Description | 23-5 |
| 23.2.1 eMIOS[n] | 23-5 |
| 23.2.2 Output Disable Input — eMIOS200 Output Disable Input Signal | 23-5 |
| 23.3 Memory Map and Register Description | 23-6 |
| 23.3.1 Memory Map | 23-6 |
| 23.3.2 Register Descriptions | 23-8 |
| 23.3.2.1 eMIOS200 Module Configuration Register (EMIOS_MCR) | 23-8 |
| 23.3.2.2 eMIOS200 Global Flag Register (EMIOS_GFR) | 23-9 |
| 23.3.2.3 eMIOS200 Output Update Disable Register (EMIOS_OUDR) | 23-10 |
| 23.3.2.4 eMIOS200 A Register (EMIOS_CADR[n]) | 23-10 |
| 23.3.2.5 eMIOS200 B Register (EMIOS_CBDR[n]) | 23-11 |
| 23.3.2.6 eMIOS200 Counter Register (EMIOS_CCNTR[n]) | 23-12 |
| 23.3.2.7 eMIOS200 Control Register (EMIOS_CCR[n]) | 23-12 |
| 23.3.2.8 eMIOS200 Status Register (EMIOS_CSR[n]) | 23-18 |
| 23.3.2.9 eMIOS200 Alternate A Register (EMIOS_ALTA[n]) | 23-19 |
| 23.3.3 Functional Description | 23-20 |
| 23.3.3.1 Unified Channel (UC) | 23-20 |
| 23.3.3.1.1 Unified Channel Modes of Operation | 23-22 |
| 23.3.3.1.2 Input Programmable Filter (IPF) | 23-62 |
| 23.3.3.1.3 Clock Prescaler (CP) | 23-62 |
| 23.3.3.1.4 Effect of Freeze on the Unified Channel | 23-63 |
| 23.3.3.2 IP Bus Interface Unit (BIU) | 23-63 |
| 23.3.3.2.1 Effect of Freeze on the BIU | 23-63 |
| 23.3.3.3 STAC Client Submodule | 23-63 |
| 23.3.3.3.1 Effect of Freeze on the STAC Client Submodule | 23-65 |
| 23.3.3.4 Global Clock Prescaler Submodule (GCP) | 23-65 |
| 23.3.3.4.1 Effect of Freeze on the GCP | 23-65 |
| 23.4 Reset | 23-65 |
| 23.5 Interrupts | 23-65 |

| | | |
|--------|--|-------|
| 23.7 | Initialization/Application Information | 23-66 |
| 23.7.1 | Considerations | 23-66 |
| 23.7.2 | Application Information | 23-66 |
| 23.7.3 | Time Base Generation | 23-66 |
| 23.7.4 | Coherent Accesses | 23-69 |

Chapter 24 FlexCAN Module

| | | |
|-----------|--|-------|
| 24.1 | Introduction | 24-1 |
| 24.1.1 | Overview | 24-2 |
| 24.1.2 | FlexCAN Module Features | 24-3 |
| 24.1.3 | Modes of Operation | 24-4 |
| 24.2 | External Signal Description | 24-5 |
| 24.2.1 | Overview | 24-5 |
| 24.2.2 | Signal Descriptions | 24-5 |
| 24.2.2.1 | CAN Rx | 24-5 |
| 24.2.2.2 | CAN Tx | 24-5 |
| 24.3 | Memory Map/Register Definition | 24-5 |
| 24.3.1 | FlexCAN Memory Mapping | 24-5 |
| 24.3.2 | Message Buffer Structure | 24-8 |
| 24.3.3 | Rx FIFO Structure | 24-12 |
| 24.3.4 | Register Descriptions | 24-14 |
| 24.3.4.1 | Module Configuration Register (FLEXCAN_x_MCR) | 24-14 |
| 24.3.4.2 | Control Register (FLEXCAN_x_CTRL) | 24-18 |
| 24.3.4.3 | Free Running Timer (FLEXCAN_x_TIMER) | 24-21 |
| 24.3.4.4 | Rx Global Mask (FLEXCAN_x_RXGMASK) | 24-22 |
| 24.3.4.5 | Rx 14 Mask (FLEXCAN_x_RX14MASK) | 24-22 |
| 24.3.4.6 | Rx 15 Mask (FLEXCAN_x_RX15MASK) | 24-23 |
| 24.3.4.7 | Error Counter Register (FLEXCAN_x_ECR) | 24-23 |
| 24.3.4.8 | Error and Status Register (FLEXCAN_x_ESR) | 24-25 |
| 24.3.4.9 | Interrupt Masks 2 Register (FLEXCAN_x_IMASK2) | 24-28 |
| 24.3.4.10 | Interrupt Masks 1 Register (FLEXCAN_x_IMASK1) | 24-28 |
| 24.3.4.11 | Interrupt Flags 2 Register (FLEXCAN_x_IFLAG2) | 24-29 |
| 24.3.4.12 | Interrupt Flags 1 Register (FLEXCAN_x_IFLAG1) | 24-30 |
| 24.3.4.13 | Rx Individual Mask Registers (RXIMR0–RXIMR63) | 24-32 |
| 24.4 | Functional Description | 24-32 |
| 24.4.1 | Overview | 24-32 |
| 24.4.2 | Transmit Process | 24-33 |
| 24.4.3 | Arbitration process | 24-33 |
| 24.4.4 | Receive Process | 24-34 |
| 24.4.5 | Matching Process | 24-36 |
| 24.4.6 | Data Coherence | 24-37 |
| 24.4.6.1 | Transmission Abort Mechanism | 24-37 |
| 24.4.6.2 | Message Buffer Deactivation | 24-38 |
| 24.4.6.3 | Message Buffer Lock Mechanism | 24-39 |
| 24.4.7 | Rx FIFO | 24-39 |
| 24.4.7.1 | Precautions when using Global Mask and Individual Mask registers | 24-40 |
| 24.4.8 | CAN protocol Related Features | 24-41 |
| 24.4.8.1 | Remote Frames | 24-41 |
| 24.4.8.2 | Overload Frames | 24-41 |
| 24.4.8.3 | Time Stamp | 24-42 |
| 24.4.8.4 | Protocol Timing | 24-42 |
| 24.4.8.5 | Arbitration and Matching Timing | 24-44 |
| 24.4.9 | Modes of Operation Details | 24-45 |
| 24.4.9.1 | Freeze Mode | 24-45 |
| 24.4.9.2 | Module Disable Mode | 24-46 |
| 24.4.9.3 | Stop Mode | 24-46 |
| 24.4.10 | Interrupts | 24-46 |
| 24.4.11 | Bus Interface | 24-47 |
| 24.5 | Initialization/Application Information | 24-48 |
| 24.5.1 | FlexCAN Initialization Sequence | 24-48 |
| 24.5.2 | FlexCAN Addressing and RAM size configurations | 24-49 |

Chapter 25

Deserial Serial Peripheral Interface (DSPI)

| | | |
|-----------|--|-------|
| 25.1 | Introduction | 25-1 |
| 25.1.1 | Overview | 25-2 |
| 25.1.2 | Features | 25-2 |
| 25.1.3 | DSPI Configurations | 25-4 |
| 25.1.3.1 | SPI Configuration | 25-4 |
| 25.1.3.2 | DSI Configuration | 25-4 |
| 25.1.3.3 | CSI Configuration | 25-5 |
| 25.1.4 | Modes of Operation | 25-5 |
| 25.1.4.1 | Master Mode | 25-5 |
| 25.1.4.2 | Slave Mode | 25-5 |
| 25.1.4.3 | Module Disable Mode | 25-5 |
| 25.1.4.4 | External Stop Mode | 25-5 |
| 25.1.4.5 | Debug Mode | 25-6 |
| 25.2 | External Signal Description | 25-6 |
| 25.2.1 | Overview | 25-6 |
| 25.2.2 | Detailed Signal Description | 25-6 |
| 25.2.2.1 | PCS[0]/ \overline{SS} — Peripheral Chip Select/Slave Select | 25-6 |
| 25.2.2.2 | PCS[1] - PCS[3] — Peripheral Chip Selects 1 - 3 | 25-6 |
| 25.2.2.3 | PCS[4]/MTRIG — Peripheral Chip Select 4/Master Trigger | 25-7 |
| 25.2.2.4 | PCS[5]/PCSS — Peripheral Chip Select 5/Peripheral Chip Select Strobe | 25-7 |
| 25.2.2.5 | SIN — Serial Input | 25-7 |
| 25.2.2.6 | SOUT — Serial Output | 25-7 |
| 25.2.2.7 | SCK — Serial Clock | 25-7 |
| 25.2.2.8 | HT — Hardware Trigger | 25-7 |
| 25.3 | Memory Map and Register Definition | 25-8 |
| 25.3.1 | Memory Map | 25-8 |
| 25.3.2 | Register Descriptions | 25-9 |
| 25.3.2.1 | DSPI Module Configuration Register (DSPI_MCR) | 25-9 |
| 25.3.2.2 | DSPI Transfer Count Register (DSPI_TCR) | 25-11 |
| 25.3.2.3 | DSPI Clock and Transfer Attributes Registers 0–7 (DSPI_CTAR0–DSPI_CTAR7) | 25-12 |
| 25.3.2.4 | DSPI Status Register (DSPI_SR) | 25-18 |
| 25.3.2.5 | DSPI DMA/Interrupt Request Select and Enable Register (DSPI_RSER) | 25-20 |
| 25.3.2.6 | DSPI PUSH TX FIFO Register (DSPI_PUSHR) | 25-22 |
| 25.3.2.7 | DSPI POP RX FIFO Register (DSPI_POPR) | 25-23 |
| 25.3.2.8 | DSPI Transmit FIFO Registers 0–3 (DSPI_TXFR0–DSPI_TXFR3) | 25-24 |
| 25.3.2.9 | DSPI Receive FIFO Registers 0–3 (DSPI_RXFR0–DSPI_RXFR3) | 25-25 |
| 25.3.2.10 | DSPI DSI Configuration Register (DSPI_DSICR) | 25-25 |
| 25.3.2.11 | DSPI DSI Serialization Data Register (DSPI_SDR) | 25-27 |
| 25.3.2.12 | DSPI DSI Alternate Serialization Data Register (DSPI_AS DR) | 25-28 |
| 25.3.2.13 | DSPI DSI Transmit Comparison Register (DSPI_COMP R) | 25-29 |
| 25.3.2.14 | DSPI DSI Deserialization Data Register (DSPI_DDR) | 25-29 |
| 25.3.2.15 | DSPI DSI Configuration Register 1 (DSPI_DSICR1) | 25-30 |
| 25.4 | Functional Description | 25-31 |
| 25.4.1 | Modes of Operation | 25-33 |
| 25.4.1.1 | Master Mode | 25-33 |
| 25.4.1.2 | Slave Mode | 25-33 |
| 25.4.1.3 | Module Disable Mode | 25-34 |
| 25.4.1.4 | External Stop Mode | 25-34 |
| 25.4.1.5 | Debug Mode | 25-34 |
| 25.4.2 | Start and Stop of DSPI Transfers | 25-34 |
| 25.4.3 | Serial Peripheral Interface (SPI) Configuration | 25-35 |
| 25.4.3.1 | Master Mode | 25-36 |
| 25.4.3.2 | Slave Mode | 25-36 |
| 25.4.3.3 | FIFO Disable Operation | 25-36 |
| 25.4.3.4 | Transmit First In First Out (TX FIFO) Buffering Mechanism | 25-36 |
| 25.4.3.5 | Receive First In First Out (RX FIFO) Buffering Mechanism | 25-37 |
| 25.4.4 | Deserial Serial Interface (DSI) Configuration | 25-38 |
| 25.4.4.1 | DSI Master Mode | 25-38 |
| 25.4.4.2 | DSI Slave Mode | 25-39 |
| 25.4.4.3 | DSI Serialization | 25-39 |

| | | |
|-----------|---|-------|
| 25.4.4.4 | DSI Deserialization | 25-40 |
| 25.4.4.5 | DSI Transfer Initiation Control | 25-40 |
| 25.4.4.6 | Multiple Transfer Operation (MTO) | 25-41 |
| 25.4.5 | Combined Serial Interface (CSI) Configuration | 25-43 |
| 25.4.5.1 | CSI Serialization | 25-44 |
| 25.4.5.2 | CSI Deserialization | 25-45 |
| 25.4.6 | DSPI Baud Rate and Clock Delay Generation | 25-46 |
| 25.4.6.1 | Baud Rate Generator | 25-46 |
| 25.4.6.2 | PCS to SCK Delay (t_{CSC}) | 25-46 |
| 25.4.6.3 | After SCK Delay (t_{ASC}) | 25-46 |
| 25.4.6.4 | Delay after Transfer (t_{DT}) | 25-47 |
| 25.4.6.5 | Peripheral Chip Select Strobe Enable (PCSS) | 25-48 |
| 25.4.7 | Transfer Formats | 25-49 |
| 25.4.7.1 | Classic SPI Transfer Format (CPHA = 0) | 25-49 |
| 25.4.7.2 | Classic SPI Transfer Format (CPHA = 1) | 25-50 |
| 25.4.7.3 | Modified SPI/DSI Transfer Format (MTFE = 1, CPHA = 0) | 25-51 |
| 25.4.7.4 | Modified SPI/DSI Transfer Format (MTFE = 1, CPHA = 1) | 25-52 |
| 25.4.7.5 | Continuous Selection Format | 25-53 |
| 25.4.8 | Continuous Serial Communications Clock | 25-55 |
| 25.4.9 | Timed Serial Bus (TSB) | 25-56 |
| 25.4.9.1 | PCS Switch Over Timing | 25-58 |
| 25.4.9.2 | TSB Command Frame Format | 25-59 |
| 25.4.9.3 | TSB Data Frame Format | 25-59 |
| 25.4.10 | Interrupts/DMA Requests | 25-60 |
| 25.4.10.1 | End of Queue Interrupt Request | 25-60 |
| 25.4.10.2 | Transmit FIFO Fill Interrupt or DMA Request | 25-60 |
| 25.4.10.3 | Transfer Complete Interrupt Request | 25-61 |
| 25.4.10.4 | Transmit FIFO Underflow Interrupt Request | 25-61 |
| 25.4.10.5 | Receive FIFO Drain Interrupt or DMA Request | 25-61 |
| 25.4.10.6 | Receive FIFO Overflow Interrupt Request | 25-61 |
| 25.4.11 | Power Saving Features | 25-61 |
| 25.4.11.1 | Stop Mode (External Stop Mode) | 25-62 |
| 25.4.11.2 | Module Disable Mode | 25-62 |
| 25.4.11.3 | Slave Bus Signal Gating | 25-63 |
| 25.5 | Initialization/Application Information | 25-63 |
| 25.5.1 | How to Change Queues | 25-63 |
| 25.5.2 | Baud Rate Settings | 25-64 |
| 25.5.3 | Delay Settings | 25-64 |
| 25.5.4 | Calculation of FIFO Pointer Addresses | 25-65 |
| 25.5.4.1 | Address Calculation for the First-in Entry and Last-in Entry in the TX FIFO | 25-66 |
| 25.5.4.2 | Address Calculation for the First-in Entry and Last-in Entry in the RX FIFO | 25-66 |

Chapter 26 Enhanced Serial Communication Interface (eSCI)

| | | |
|----------|------------------------------------|------|
| 26.1 | Introduction | 26-1 |
| 26.1.1 | Bibliography | 26-1 |
| 26.1.2 | Acronyms and Abbreviations | 26-1 |
| 26.1.3 | Glossary | 26-1 |
| 26.1.4 | Overview | 26-2 |
| 26.1.5 | Features | 26-3 |
| 26.1.6 | Modes of Operation | 26-4 |
| 26.1.6.1 | SCI Mode | 26-4 |
| 26.1.6.2 | LIN Mode | 26-4 |
| 26.1.6.3 | Disabled Mode | 26-4 |
| 26.1.6.4 | Stop Mode | 26-5 |
| 26.2 | External Signal Description | 26-6 |
| 26.2.1 | Detailed Signal Descriptions | 26-6 |
| 26.2.1.1 | eSCI Transmit Pin (TXD) | 26-6 |
| 26.2.1.2 | eSCI Receive Pin (RXD) | 26-6 |
| 26.3 | Memory Map and Register Definition | 26-6 |
| 26.3.1 | Memory Map | 26-6 |
| 26.3.2 | Register Descriptions | 26-7 |
| 26.3.2.1 | Baud Rate Register (eSCI_BRR) | 26-8 |

| | | |
|-----------|---|-------|
| 26.3.2.2 | Control Register 1 (eSCI_CR1) | 26-8 |
| 26.3.2.3 | Control Register 2 (eSCI_CR2) | 26-10 |
| 26.3.2.4 | SCI Data Register (ESCI_DR) | 26-12 |
| 26.3.2.5 | Interrupt Flag and Status Register 1 (eSCI_IFSR1) | 26-13 |
| 26.3.2.6 | Interrupt Flag and Status Register 2 (eSCI_IFSR2) | 26-14 |
| 26.3.2.7 | LIN Control Register 1 (eSCI_LCR1) | 26-15 |
| 26.3.2.8 | LIN Control Register 2 (eSCI_LCR2) | 26-17 |
| 26.3.2.9 | LIN Transmit Register (eSCI_LTR) | 26-17 |
| 26.3.2.10 | LIN Receive Register (eSCI_LRR) | 26-19 |
| 26.3.2.11 | LIN CRC Polynomial Register (eSCI_LPR) | 26-19 |
| 26.3.2.12 | Control Register 3 (eSCI_CR3) | 26-19 |
| 26.4 | Functional Description | 26-21 |
| 26.4.1 | Module Control | 26-21 |
| 26.4.2 | Frame Formats | 26-21 |
| 26.4.2.1 | Data Frame Formats | 26-21 |
| 26.4.2.2 | Break Character Formats | 26-23 |
| 26.4.2.3 | Idle Character Formats | 26-24 |
| 26.4.3 | Baud Rate and Clock Generation | 26-24 |
| 26.4.3.1 | Module Clock | 26-25 |
| 26.4.3.2 | Transmitter Clock | 26-25 |
| 26.4.3.3 | Receiver Clock | 26-25 |
| 26.4.4 | Baud Rate Tolerance | 26-26 |
| 26.4.4.1 | Faster Receiver Tolerance | 26-26 |
| 26.4.4.2 | Slower Receiver Tolerance | 26-27 |
| 26.4.5 | SCI Mode | 26-28 |
| 26.4.5.1 | SCI Mode Configuration | 26-28 |
| 26.4.5.2 | Transmitter | 26-28 |
| 26.4.5.3 | Receiver | 26-32 |
| 26.4.5.4 | Reception Error Reporting | 26-41 |
| 26.4.5.5 | Multiprocessor Communication | 26-42 |
| 26.4.6 | LIN Mode | 26-43 |
| 26.4.6.1 | LIN Mode Configuration | 26-43 |
| 26.4.6.2 | LIN frame formats | 26-44 |
| 26.4.6.3 | LIN TX Frame generation | 26-44 |
| 26.4.6.4 | LIN RX frame generation | 26-46 |
| 26.4.6.5 | LIN Error Reporting | 26-48 |
| 26.4.6.6 | LIN Wakeup | 26-50 |
| 26.4.6.7 | LIN Protocol Engine Reset | 26-51 |
| 26.4.7 | Interrupts | 26-51 |
| 26.4.7.1 | Interrupt Flags and Enables | 26-51 |
| 26.4.7.2 | Interrupt Request Generation | 26-52 |
| 26.5 | Application Information | 26-52 |
| 26.5.1 | SCI Data Frames Separated by Preamble | 26-52 |

Chapter 27

Enhanced Queued Analog-to-Digital Converter (EQADC)

| | | |
|--------|---|-------|
| 27.1 | Overview | 27-1 |
| 27.1.1 | Analog to Digital Conversion Sub-system | 27-2 |
| 27.2 | Block Diagram | 27-3 |
| 27.2.1 | Features | 27-4 |
| 27.3 | Modes of Operation | 27-5 |
| 27.3.1 | Normal Mode | 27-6 |
| 27.3.2 | Streaming Mode | 27-6 |
| 27.3.3 | Debug Mode | 27-6 |
| 27.3.4 | Stop Mode | 27-7 |
| 27.4 | External Signal Description | 27-8 |
| 27.4.1 | Overview | 27-8 |
| 27.4.2 | Detailed Signal Descriptions | 27-9 |
| 27.5 | Pin Mapping to Channel Mapping | 27-11 |
| 27.6 | Memory Map/Register Definition | 27-13 |
| 27.6.1 | EQADC Memory Map | 27-13 |
| 27.6.2 | EQADC Register Descriptions | 27-16 |

| | | |
|-----------|--|--------|
| 27.6.2.1 | EQADC Module Configuration Register (EQADC_MCR) | 27-16 |
| 27.6.2.2 | EQADC External Trigger Digital Filter Register (EQADC_ETDFR) | 27-17 |
| 27.6.2.3 | EQADC CFIFO Push Registers (EQADC_CFPR) | 27-18 |
| 27.6.2.4 | EQADC Result FIFO Pop Registers (EQADC_RFPR) | 27-19 |
| 27.6.2.5 | EQADC CFIFO Control Registers (EQADC_CFCR) | 27-19 |
| 27.6.2.6 | EQADC Interrupt and DMA Control Registers (EQADC_IDCR) | 27-22 |
| 27.6.2.7 | EQADC FIFO and Interrupt Status Registers (EQADC_FISR) | 27-25 |
| 27.6.2.8 | EQADC CFIFO Transfer Counter Registers (EQADC_CFTCR) | 27-29 |
| 27.6.2.9 | EQADC CFIFO Status Snapshot Registers (EQADC_CFSSR) | 27-30 |
| 27.6.2.10 | EQADC CFIFO Status Register (EQADC_CFSR) | 27-32 |
| 27.6.2.11 | EQADC Red Line Client Configuration Register (EQADC_REDLCCR) | 27-33 |
| 27.6.2.12 | EQADC CFIFO Registers (EQADC_CFRw) (x=0, ..., 5; w=0, ..., 3) | 27-34 |
| 27.6.2.13 | EQADC CFIFO0 Extension Registers (EQADC_CF0ERw) (w=0, ..., 3) | 27-37 |
| 27.6.2.14 | EQADC RFIFO Registers (EQADC_RFRw) (x=0, ..., 5; w=0, ..., 3) | 27-37 |
| 27.6.3 | On-Chip ADC Registers | 27-40 |
| 27.6.3.1 | ADC0/1 Control Registers (ADC0_CR and ADC1_CR) | 27-42 |
| 27.6.3.2 | ADC Time Stamp Control Register (ADC_TSCR) | 27-46 |
| 27.6.3.3 | ADC Time Base Counter Registers (ADC_TBCR) | 27-47 |
| 27.6.3.4 | ADC0/1 Gain Calibration Constant Registers (ADC0_GCCR and ADC1_GCCR) | 27-47 |
| 27.6.3.5 | ADC0/1 Offset Calibration Constant Registers (ADC0_OCCR and ADC1_OCCR) | 27-48 |
| 27.6.3.6 | Alternate Configuration 1-8 Control Registers (ADC_ACR1-8) | 27-49 |
| 27.6.3.7 | ADC0/1 Alternate Gain Registers (ADC0_AGR1-2 and ADC1_AGR1-2) | 27-51 |
| 27.6.3.8 | ADC0/1 Alternate Offset Register (ADC0_AOR1-2 and ADC1_AOR1-2) | 27-52 |
| 27.6.3.9 | ADC Pull Up/Down Control Register x (ADC_PUDCRx, x=0-7) | 27-52 |
| 27.7 | Functional Description | 27-53 |
| 27.7.1 | Overview | 27-53 |
| 27.7.2 | Data Flow in EQADC | 27-54 |
| 27.7.2.1 | Overview and Basic Terminology | 27-54 |
| 27.7.2.2 | Message Format in EQADC | 27-56 |
| 27.7.3 | Command/Result Queues | 27-67 |
| 27.7.4 | EQADC Command FIFOs | 27-67 |
| 27.7.4.1 | CFIFO Basic Functionality | 27-67 |
| 27.7.4.2 | CFIFO0 Streaming Mode Description | 27-70 |
| 27.7.4.3 | CFIFO Common Prioritization and Command Transfer | 27-75 |
| 27.7.4.4 | CFIFO Prioritization in Abort Mode | 27-77 |
| 27.7.4.5 | Hardware Trigger Event Detection | 27-78 |
| 27.7.4.6 | CFIFO Scan Trigger Modes | 27-78 |
| 27.7.4.7 | CFIFO and Trigger Status | 27-83 |
| 27.7.5 | EQADC Result FIFOs | 27-91 |
| 27.7.5.1 | RFIFO Basic Functionality | 27-91 |
| 27.7.5.2 | Distributing Result Data into RFIFOs | 27-94 |
| 27.7.6 | On-Chip ADC Configuration and Control | 27-95 |
| 27.7.6.1 | Enabling and Disabling the On-chip ADCs | 27-95 |
| 27.7.6.2 | ADC Clock and Conversion Speed | 27-96 |
| 27.7.6.3 | Time Stamp Feature | 27-98 |
| 27.7.6.4 | ADC Pre-gain Feature | 27-98 |
| 27.7.6.5 | ADC Resolution Selection Feature | 27-98 |
| 27.7.6.6 | ADC Calibration Feature | 27-99 |
| 27.7.6.7 | ADC Control Logic overview and command execution | 27-101 |
| 27.7.7 | Internal/External Multiplexing | 27-104 |
| 27.7.7.1 | Channel Assignment | 27-104 |
| 27.7.7.2 | External Multiplexing | 27-107 |
| 27.7.8 | EQADC DMA/Interrupt Request | 27-110 |
| 27.7.9 | Analog Sub-Block | 27-113 |
| 27.7.9.1 | Analog to Digital Converter (ADC) | 27-113 |
| 27.8 | Initialization/Application Information | 27-116 |
| 27.8.1 | Multiple Queues Control Setup Example | 27-116 |
| 27.8.1.1 | EQADC Initialization | 27-117 |
| 27.8.1.2 | Configuring EQADC for Applications | 27-118 |
| 27.8.2 | EQADC/DMAC Interface | 27-120 |
| 27.8.2.1 | CQueue/CFIFO Transfers | 27-120 |
| 27.8.2.2 | RQueue/RFIFO Transfers | 27-121 |
| 27.8.3 | Sending Immediate Command Setup Example | 27-122 |

| | |
|--|--------|
| 27.8.4 Modifying Queues | 27-123 |
| 27.8.5 CQueue and RQueues Usage | 27-124 |
| 27.8.6 ADC Result Calibration | 27-126 |
| 27.8.6.1 MAC Configuration Procedure | 27-126 |
| 27.8.6.2 Example | 27-127 |
| 27.8.6.3 Quantization Error Reduction During Calibration | 27-127 |
| 27.8.7 EQADC Versus QADC | 27-128 |

Chapter 28

Decimation Filter

| | |
|---|-------|
| 28.1 Overview | 28-1 |
| 28.1.1 Features | 28-4 |
| 28.1.2 Modes of Operation Overview | 28-4 |
| 28.1.2.1 Normal Mode | 28-4 |
| 28.1.2.2 Freeze Mode | 28-5 |
| 28.1.2.3 Disabled Mode | 28-5 |
| 28.2 Memory Map and Register Definition | 28-5 |
| 28.2.1 Decimation Filter Memory Map | 28-5 |
| 28.2.2 Decimation Filter Register Descriptions | 28-7 |
| 28.2.2.1 Decimation Filter Module Configuration Register (DECFLT_x_MCR) | 28-7 |
| 28.2.2.2 Decimation Filter Module Status Register (DECFLT_x_MSR) | 28-11 |
| 28.2.2.3 Decimation Filter Module Extended Configuration Register (DECFLT_x_MXCR) | 28-13 |
| 28.2.2.4 Decimation Filter Module Extended Status Register (DECFLT_x_MXSR) | 28-16 |
| 28.2.2.5 Decimation Filter Interface Input Buffer Register (DECFLT_x_IB) | 28-19 |
| 28.2.2.6 Decimation Filter Interface Output Buffer Register (DECFLT_x_OB) | 28-20 |
| 28.2.2.7 Decimation Filter Coefficient n Register (DECFLT_x_COEFn) | 28-20 |
| 28.2.2.8 Decimation Filter TAPn Register (DECFLT_x_TAPn) | 28-21 |
| 28.2.2.9 Decimation Filter Interface Enhanced Debug Input Data Register (DECFLT_x_EDID) | 28-22 |
| 28.2.2.10 Decimation Filter Final Integration Value Register (DECFLT_x_FINTVAL) | 28-23 |
| 28.2.2.11 Decimation Filter Final Integration Count Value Register (DECFLT_x_FINTCNT) | 28-23 |
| 28.2.2.12 Decimation Filter Current Integration Value Register (DECFLT_x_CINTVAL) | 28-24 |
| 28.2.2.13 Decimation Filter Current Integration Count Value Register (DECFLT_x_CINTCNT) | 28-24 |
| 28.3 Functional Description | 28-25 |
| 28.3.1 Decimation Filter Input | 28-25 |
| 28.3.1.1 Input Buffer Overrun | 28-25 |
| 28.3.2 Decimation Filter Output | 28-26 |
| 28.3.2.1 Output Buffer Overrun | 28-26 |
| 28.3.3 Bypass Operation | 28-27 |
| 28.3.4 Filter Prefill Control | 28-27 |
| 28.3.5 Timestamp Data Transmission | 28-29 |
| 28.3.5.1 Timestamp Data | 28-29 |
| 28.3.5.2 Timestamp Management | 28-29 |
| 28.3.6 Flush Command | 28-29 |
| 28.3.7 Soft Reset Command | 28-30 |
| 28.3.8 Freeze Mode | 28-30 |
| 28.3.9 Filter Implementation | 28-30 |
| 28.3.10 Rounding | 28-31 |
| 28.3.11 Saturation | 28-32 |
| 28.3.12 Interrupts and DMA Overview | 28-32 |
| 28.3.12.1 Input Buffer Interrupt and DMA Requests | 28-33 |
| 28.3.12.2 Output Buffer Interrupt and DMA Requests | 28-34 |
| 28.3.12.3 Integrator Interrupt and DMA Requests | 28-35 |
| 28.3.13 Integrator | 28-35 |
| 28.3.13.1 Integrator Inputs | 28-35 |
| 28.3.13.2 Integrator Output | 28-36 |
| 28.3.13.3 Integrator Reset | 28-37 |
| 28.3.13.4 Integrator Enabling and Halting | 28-38 |
| 28.3.13.5 Integrator Exceptions | 28-38 |
| 28.3.14 Cascade Mode | 28-39 |
| 28.3.14.1 Example Configurations | 28-41 |
| 28.3.14.2 Cascade Freeze, Stop, and Configuration Change Procedures | 28-42 |
| 28.3.15 Enhanced Debug Monitor Description | 28-43 |

| | | |
|----------|---|-------|
| 28.4 | Application Information | 28-43 |
| 28.4.1 | eQADC Configuration for Decimation Filter Operation | 28-43 |
| 28.4.1.1 | eQADC Configuration / Decimation Filter Input | 28-43 |
| 28.4.1.2 | eQADC Configuration / Decimator Output | 28-45 |
| 28.5 | Use Cases | 28-46 |
| 28.5.1 | IIR Filter Configuration | 28-46 |
| 28.5.2 | Initialization Procedure | 28-49 |
| 28.5.2.1 | Use Case 1 - Normal mode, ADC conversion and filtering. | 28-50 |
| 28.5.2.2 | Use Case 2 - Input/Output from/to the CPU/DMA, Stored data filtering. | 28-52 |

Chapter 29

Enhanced Time Processing Unit (eTPU2)

| | | |
|-----------|--|-------|
| 29.1 | Introduction | 29-1 |
| 29.1.1 | Overview | 29-2 |
| 29.1.1.1 | eTPU Engine | 29-4 |
| 29.1.2 | Features | 29-7 |
| 29.1.2.1 | eTPU Feature Summary | 29-7 |
| 29.1.2.2 | eTPU Enhancements over TPU3 | 29-10 |
| 29.1.2.3 | eTPU2 Enhancements over eTPU | 29-10 |
| 29.1.3 | Modes of Operation | 29-11 |
| 29.1.3.1 | eTPU Mode Selection | 29-12 |
| 29.2 | External Signal Description | 29-13 |
| 29.2.1 | Overview | 29-13 |
| 29.2.2 | Detailed Signal Descriptions | 29-13 |
| 29.2.2.1 | eTPU Channel Output Signals [0-31] | 29-13 |
| 29.2.2.2 | eTPU Channel Input Signals [0-31] | 29-13 |
| 29.2.2.3 | Time Base Clock Signal — TCRCLK | 29-14 |
| 29.2.2.4 | eTPU Channel Output Disable Signals | 29-14 |
| 29.2.3 | Memory Map/Register Definition | 29-15 |
| 29.2.4 | Memory Map | 29-15 |
| 29.2.5 | System Configuration Registers | 29-19 |
| 29.2.5.1 | ETPUMCR - eTPU Module Configuration Register | 29-19 |
| 29.2.5.2 | ETPUCDCCR - eTPU Coherent Dual-Parameter Controller Register | 29-22 |
| 29.2.5.3 | ETPUMISCCMPR - eTPU MISC Compare Register | 29-23 |
| 29.2.5.4 | ETPUSCMOFFDATAR - eTPU SCM Off-range Data Register | 29-24 |
| 29.2.5.5 | ETPUCECR - eTPU Engine Configuration Register | 29-24 |
| 29.2.6 | Time Base Registers | 29-27 |
| 29.2.6.1 | ETPUTBCR - eTPU Time Base Configuration Register | 29-28 |
| 29.2.6.2 | ETPUTB1R - eTPU Time Base 1 (TCR1) Visibility Register | 29-31 |
| 29.2.6.3 | ETPUTB2R - eTPU Time Base 2 (TCR2) Visibility Register | 29-31 |
| 29.2.6.4 | ETPUREDCR - eTPU STAC Configuration Register | 29-32 |
| 29.2.7 | Engine Related Registers | 29-33 |
| 29.2.7.1 | ETPUWDTR - eTPU Watchdog Timer Register | 29-33 |
| 29.2.7.2 | ETPUIDLER - eTPU Idle Register | 29-34 |
| 29.2.8 | Channel Registers Layout | 29-34 |
| 29.2.9 | Global Channel Registers | 29-35 |
| 29.2.9.1 | ETPUCISR - eTPU Channel Interrupt Status Register | 29-35 |
| 29.2.9.2 | ETPUCDTRSR - eTPU Channel Data Transfer Request Status Register | 29-36 |
| 29.2.9.3 | ETPUCIOSR - eTPU Channel Interrupt Overflow Status Register | 29-37 |
| 29.2.9.4 | ETPUCDTROS - eTPU Channel Data Transfer Request Overflow Status Register | 29-38 |
| 29.2.9.5 | ETPUCIER - eTPU Channel Interrupt Enable Register | 29-39 |
| 29.2.9.6 | ETPUCDTRER - eTPU Channel Data Transfer Request Enable Register | 29-39 |
| 29.2.9.7 | ETPUCSSR - eTPU Channel Pending Service Status Register | 29-40 |
| 29.2.9.8 | ETPUCSSR - eTPU Channel Service Status Register | 29-41 |
| 29.2.10 | Channel Configuration and Control Registers | 29-42 |
| 29.2.10.1 | ETPUCxCR - eTPU Channel x Configuration Register | 29-43 |
| 29.2.10.2 | ETPUCxSCR - eTPU Channel x Status Control Register | 29-45 |
| 29.2.10.3 | ETPUCxHSRR - eTPU Channel x Host Service Request Register | 29-47 |
| 29.3 | Functional Description | 29-47 |
| 29.3.1 | Watchdog | 29-47 |
| 29.3.2 | Host Interface | 29-48 |
| 29.3.2.1 | System Configuration | 29-48 |

| | | |
|----------|--|-------|
| 29.3.2.2 | Interrupts and Data Transfer Requests | 29-48 |
| 29.3.2.3 | Parameter Access | 29-50 |
| 29.3.2.4 | SDM Organization | 29-51 |
| 29.3.2.5 | Host Service Requests | 29-53 |
| 29.3.2.6 | SCM access | 29-53 |
| 29.3.2.7 | Bus Error Conditions | 29-55 |
| 29.3.3 | Scheduler | 29-55 |
| 29.3.3.1 | Channel Enabling and Priority Assignment | 29-55 |
| 29.3.3.2 | Channel Priority Schemes | 29-56 |
| 29.3.3.3 | Time Slot Latency | 29-62 |
| 29.3.4 | Parameter Sharing and Coherency | 29-62 |
| 29.3.4.1 | Host Side Atomic Access | 29-63 |
| 29.3.4.2 | Coherent Dual-parameter Controller - CDC | 29-63 |
| 29.3.4.3 | SDM Arbitration | 29-64 |
| 29.3.4.4 | Enhanced Digital Filter - EDF | 29-65 |
| 29.3.5 | Time Bases | 29-67 |
| 29.3.5.1 | Timer Count Register 1 - TCR1 | 29-67 |
| 29.3.5.2 | Timer Count Register 2 - TCR2 | 29-68 |
| 29.3.5.3 | STAC Interface | 29-71 |
| 29.3.5.4 | GTBE - Global Time Base Enable | 29-73 |
| 29.3.5.5 | TCRCLK Digital Filter | 29-73 |
| 29.3.6 | Safety Features | 29-74 |
| 29.3.6.1 | SCM Test - Multiple Input Signature Calculator | 29-74 |
| 29.3.7 | Performance Monitoring Features | 29-75 |
| 29.3.7.1 | Idle Counter | 29-75 |
| 29.4 | Initialization/Application Information | 29-76 |
| 29.4.1 | Multiple Parameter Coherency Methods | 29-76 |
| 29.4.2 | Estimating Worst Case Latency | 29-76 |
| 29.4.2.1 | Introduction to Worst-Case Latency | 29-77 |
| 29.4.2.2 | Using Worst-Case Latency Estimates to Evaluate Performance | 29-78 |
| 29.4.2.3 | Priority Scheme Details Used in WCL Analysis | 29-79 |
| 29.4.2.4 | First-Pass Worst-Case Latency Analysis | 29-82 |
| 29.4.2.5 | Second-Pass Worst-Case Latency Analysis | 29-88 |
| 29.4.3 | MISC Algorithm | 29-92 |

Chapter 30

External Bus Interface (EBI)

| | | |
|----------|---|------|
| 30.1 | Introduction | 30-1 |
| 30.1.1 | Overview | 30-1 |
| 30.1.2 | Features | 30-1 |
| 30.1.3 | Signal Naming | 30-2 |
| 30.1.4 | Modes of Operation | 30-2 |
| 30.1.4.1 | Single Master Mode | 30-2 |
| 30.1.4.2 | Module Disable Mode | 30-3 |
| 30.1.4.3 | Stop Mode | 30-3 |
| 30.1.4.4 | Slower-Speed Modes | 30-3 |
| 30.1.4.5 | 16-Bit Data Bus Mode | 30-3 |
| 30.1.4.6 | Multiplexed Address on Data Bus Mode | 30-4 |
| 30.1.4.7 | Debug Mode | 30-5 |
| 30.2 | External Signal Description | 30-5 |
| 30.2.1 | Overview | 30-5 |
| 30.2.2 | Address/Data Bus Configurations | 30-6 |
| 30.2.3 | Detailed Signal Descriptions | 30-6 |
| 30.2.3.1 | D_ADD [9:30] — Address Lines 9-30 | 30-6 |
| 30.2.3.2 | D_BDIP — Burst Data in Progress | 30-6 |
| 30.2.3.3 | D_CLKOUT — Clockout | 30-6 |
| 30.2.3.4 | CAL_CS [0:3] — Calibration Chip Selects 0-3 | 30-6 |
| 30.2.3.5 | D_ADD_DAT [0:31] — Data Lines 0-31 | 30-7 |
| 30.2.3.6 | D_OE — Output Enable | 30-7 |
| 30.2.3.7 | D_RD_WR — Read / Write | 30-7 |
| 30.2.3.8 | D_TA — Transfer Acknowledge | 30-7 |
| 30.2.3.9 | D_TEA — Transfer Error Acknowledge | 30-7 |

| | |
|---|-------|
| 30.2.3.10 D_TS — Transfer Start | 30-8 |
| 30.2.3.11 D_WE [0:3] — Write/Byte Enables 0-3 | 30-8 |
| 30.2.4 Signal Output Buffer Enable Logic by Mode | 30-8 |
| 30.3 Memory Map/Register Definition | 30-9 |
| 30.3.1 Register Descriptions | 30-10 |
| 30.3.1.1 EBI Module Configuration Register (EBI_MCR) | 30-10 |
| 30.3.1.2 EBI Transfer Error Status Register (EBI_TESR) | 30-11 |
| 30.3.1.3 EBI Bus Monitor Control Register (EBI_BMCR) | 30-12 |
| 30.3.1.4 EBI Base Registers (EBI_CAL_BR0-3) | 30-13 |
| 30.3.1.5 EBI Option Registers (EBI_CAL_OR0-3) | 30-15 |
| 30.4 Functional Description | 30-16 |
| 30.4.1 External Bus Interface Features | 30-16 |
| 30.4.1.1 Address Bus (up to 22 available on pins) | 30-16 |
| 30.4.1.2 32-Bit Data Bus (16-bit Data Bus Mode also supported) | 30-17 |
| 30.4.1.3 Multiplexed Address on Data Pins (internal master only) | 30-17 |
| 30.4.1.4 Memory Controller with Support for Various Memory Types | 30-17 |
| 30.4.1.5 Burst Support (wrapped only) | 30-18 |
| 30.4.1.6 Bus Monitor | 30-18 |
| 30.4.1.7 Port Size Configuration per Chip Select (16 or 32 bits) | 30-19 |
| 30.4.1.8 Configurable Wait States | 30-19 |
| 30.4.1.9 Configurable internal or external D_TA per chip select | 30-19 |
| 30.4.1.10 Support for Dynamic Calibration with up to 4 chip-selects | 30-19 |
| 30.4.1.11 Four Write/Byte Enable (D_WE) Signals | 30-19 |
| 30.4.1.12 Slower-Speed Clock Modes | 30-20 |
| 30.4.1.13 Stop and Module Disable Modes for Power Savings | 30-20 |
| 30.4.1.14 Optional Automatic D_CLKOUT Gating | 30-21 |
| 30.4.1.15 Misaligned Access Support | 30-21 |
| 30.4.1.16 Compatible with MPC5xx External Bus (with some limitations) | 30-21 |
| 30.4.2 External Bus Operations | 30-21 |
| 30.4.2.1 External Clocking | 30-21 |
| 30.4.2.2 Reset | 30-22 |
| 30.4.2.3 Basic Transfer Protocol | 30-22 |
| 30.4.2.4 Single Beat Transfer | 30-22 |
| 30.4.2.5 Burst Transfer | 30-30 |
| 30.4.2.6 Small Accesses (Small Port Size and Short Burst Length) | 30-35 |
| 30.4.2.7 Size, Alignment and Packaging on Transfers | 30-39 |
| 30.4.2.8 Termination Signals Protocol | 30-41 |
| 30.4.2.9 Non-Chip-Select Burst in 16-bit Data Bus Mode | 30-43 |
| 30.4.2.10 Calibration Bus Operation | 30-44 |
| 30.4.2.11 Misaligned Access Support | 30-45 |
| 30.4.2.12 Address Data Multiplexing | 30-48 |
| 30.5 Initialization/Application Information | 30-49 |
| 30.5.1 Booting from External Memory | 30-49 |
| 30.5.2 Running with SDR (Single Data Rate) Burst Memories | 30-50 |
| 30.5.3 Running with Asynchronous Memories | 30-50 |
| 30.5.3.1 Example Wait State Calculation | 30-50 |
| 30.5.3.2 Timing and Connections for Asynchronous Memories | 30-51 |
| 30.5.4 Connecting an MCU to Multiple Memories | 30-52 |
| 30.5.5 Summary of Differences from MPC5xx | 30-53 |

Chapter 31

Nexus Development Interface (NDI)

| | |
|----------------------------------|------|
| 31.1 Introduction | 31-1 |
| 31.1.1 Block Diagram | 31-2 |
| 31.1.2 Features | 31-3 |
| 31.1.3 Modes of Operation | 31-4 |
| 31.1.3.1 Nexus Reset Mode | 31-5 |
| 31.1.3.2 Full-Port Mode | 31-5 |
| 31.1.3.3 Reduced-Port Mode | 31-5 |
| 31.1.3.4 Disabled-Port Mode | 31-5 |
| 31.1.3.5 Censored Mode | 31-5 |
| 31.2 External Signal Description | 31-5 |

| | |
|--|-------|
| 31.2.1 Detailed Signal Descriptions | 31-6 |
| 31.2.1.1 Event Out (EVTO) | 31-6 |
| 31.2.1.2 Event In (EVTI) | 31-6 |
| 31.2.1.3 Message Data Out (MDO[11:0] or [15:0]) | 31-6 |
| 31.2.1.4 Message Start/End Out (MSEO[1:0]) | 31-6 |
| 31.2.1.5 Ready (RDY) | 31-7 |
| 31.2.1.6 JTAG Compliancy (JCOMP) | 31-7 |
| 31.2.1.7 Test Data Output (TDO) | 31-7 |
| 31.2.1.8 Test Clock Input (TCK) | 31-7 |
| 31.2.1.9 Test Data Input (TDI) | 31-7 |
| 31.2.1.10 Test Mode Select (TMS) | 31-7 |
| 31.3 Memory Map | 31-7 |
| 31.4 NDI Functional Description | 31-11 |
| 31.4.1 Enabling Nexus Clients for TAP Access | 31-11 |
| 31.4.2 Configuring the NDI for Nexus Messaging | 31-12 |
| 31.4.3 Programmable MCKO Frequency | 31-13 |
| 31.4.4 Nexus Messaging | 31-13 |
| 31.5 Nexus Port Controller (NPC) | 31-14 |
| 31.5.1 Overview | 31-14 |
| 31.5.2 Features | 31-14 |
| 31.6 NPC Memory Map and Register Definition | 31-15 |
| 31.6.1 Memory Map | 31-15 |
| 31.6.2 Register Descriptions | 31-16 |
| 31.6.2.1 Bypass Register | 31-16 |
| 31.6.2.2 Instruction Register | 31-16 |
| 31.6.2.3 Nexus Device ID Register (DID) | 31-17 |
| 31.6.2.4 Port Configuration Register (PCR) | 31-17 |
| 31.7 NPC Functional Description | 31-19 |
| 31.7.1 NPC Reset Configuration | 31-19 |
| 31.7.2 Auxiliary Output Port | 31-19 |
| 31.7.2.1 Output Message Protocol | 31-19 |
| 31.7.2.2 Output Messages | 31-20 |
| 31.7.2.3 IEEE 1149.1-2001 (JTAG) TAP | 31-21 |
| 31.7.2.4 Nexus Auxiliary Port Sharing | 31-26 |
| 31.7.2.5 Nexus JTAG Port Sharing | 31-26 |
| 31.7.2.6 MCKO | 31-26 |
| 31.7.2.7 EVTO Sharing | 31-26 |
| 31.7.2.8 Nexus Reset Control | 31-27 |
| 31.8 NPC Initialization and Application Information | 31-27 |
| 31.8.1 Accessing NPC Tool-Mapped Registers | 31-27 |
| 31.9 Nexus Dual eTPU Development Interface (NDEDI) | 31-27 |
| 31.10 e200z7 Class 3 Nexus Module (NZ7C3) | 31-28 |
| 31.10.1 Introduction | 31-28 |
| 31.10.2 Block Diagram | 31-29 |
| 31.10.3 Overview | 31-29 |
| 31.10.4 Features | 31-31 |
| 31.10.5 Enabling Nexus3 Operation | 31-31 |
| 31.10.6 TCODEs Supported by NZ7C3 | 31-32 |
| 31.11 NZ7C3 Memory Map and Register Definition | 31-36 |
| 31.11.1 NZ7C3 Register Access via JTAG / OnCE | 31-37 |
| 31.12 Ownership Trace | 31-38 |
| 31.12.1 Ownership Trace Messaging (OTM) | 31-38 |
| 31.12.2 OTM Error Messages | 31-39 |
| 31.12.3 OTM Flow | 31-39 |
| 31.13 Program Trace | 31-40 |
| 31.13.1 Branch Trace Messaging (BTM) | 31-40 |
| 31.13.1.1 e200z7 Indirect Branch Message Instructions (Power Architecture Book E) | 31-40 |
| 31.13.1.2 e200z7 Direct Branch Message Instructions (Power Architecture Book E) | 31-41 |
| 31.13.1.3 BTM Using Branch History Messages | 31-41 |
| 31.13.1.4 BTM Using Traditional Program Trace Messages | 31-41 |
| 31.13.2 BTM Message Formats | 31-42 |

| | | |
|------------|--|-------|
| 31.13.2.1 | Indirect Branch Messages (History) | 31-42 |
| 31.13.2.2 | Indirect Branch Messages (Traditional) | 31-42 |
| 31.13.2.3 | Direct Branch Messages (Traditional) | 31-42 |
| 31.13.2.4 | Resource Full Messages | 31-43 |
| 31.13.2.5 | Debug Status Messages | 31-43 |
| 31.13.2.6 | Program Correlation Messages | 31-44 |
| 31.13.2.7 | BTM Overflow Error Messages | 31-44 |
| 31.13.3 | Program Trace Synchronization Messages | 31-45 |
| 31.14 | BTM Operation | 31-47 |
| 31.14.1 | Enabling Program Trace | 31-47 |
| 31.14.2 | Relative Addressing | 31-47 |
| 31.14.3 | Branch and Predicate Instruction History (HIST) | 31-47 |
| 31.14.4 | Sequential Instruction Count (I-CNT) | 31-48 |
| 31.14.5 | Program Trace Queueing | 31-48 |
| 31.14.5.1 | Program Trace Timing Diagrams | 31-48 |
| 31.14.6 | Data Trace | 31-49 |
| 31.14.6.1 | Data Trace Messaging (DTM) | 31-49 |
| 31.14.6.2 | DTM Message Formats | 31-50 |
| 31.14.6.3 | DTM Operation | 31-52 |
| 31.14.6.4 | Data Trace Timing Diagrams (Eight MDO Configuration) | 31-54 |
| 31.14.7 | Watchpoint Support | 31-55 |
| 31.14.7.1 | Overview | 31-55 |
| 31.14.7.2 | Watchpoint Messaging | 31-55 |
| 31.14.7.3 | Watchpoint Error Message | 31-56 |
| 31.14.7.4 | Watchpoint Timing Diagram (Two MDO and One MSEO Configuration) | 31-57 |
| 31.14.8 | NZ7C3 Read/Write Access to Memory-Mapped Resources | 31-57 |
| 31.14.8.1 | Single Write Access | 31-57 |
| 31.14.8.2 | Block Write Access (Non-Burst Mode) | 31-58 |
| 31.14.8.3 | Block Write Access (Burst Mode) | 31-58 |
| 31.14.8.4 | Single Read Access | 31-59 |
| 31.14.8.5 | Block Read Access (Non-Burst Mode) | 31-60 |
| 31.14.8.6 | Block Read Access (Burst Mode) | 31-60 |
| 31.14.8.7 | Error Handling | 31-61 |
| 31.14.8.8 | Read/Write Access Error Message | 31-61 |
| 31.14.9 | Examples | 31-61 |
| 31.14.10 | IEEE 1149.1 (JTAG) RD/WR Sequences | 31-63 |
| 31.14.10.1 | JTAG Sequence for Accessing Internal Nexus Registers | 31-63 |
| 31.14.10.2 | JTAG Sequence for Read Access of Memory-Mapped Resources | 31-63 |
| 31.14.10.3 | JTAG Sequence for Write Access of Memory-Mapped Resources | 31-64 |
| 31.15 | Nexus Crossbar eDMA Interface (NXDM) and Nexus Crossbar FlexRay Interface (NXFR) | 31-64 |
| 31.15.1 | Block Diagrams | 31-65 |
| 31.15.2 | Features | 31-65 |
| 31.16 | External Signal Description | 31-65 |
| 31.16.1 | Rules for Output Messages | 31-66 |
| 31.16.2 | Auxiliary Port Arbitration | 31-66 |
| 31.17 | NXDM and NXFR Programmers Model | 31-66 |
| 31.17.1 | NXDM and NXFR Nexus Register Map | 31-66 |
| 31.17.2 | NXDM and NXFR Registers | 31-67 |
| 31.17.2.1 | Development Control Registers (DC1 and DC2) | 31-67 |
| 31.17.2.2 | Watchpoint Trigger Register (WT) | 31-70 |
| 31.17.2.3 | Data Trace Control Register (DTC) | 31-70 |
| 31.17.2.4 | Data Trace Start Address Registers 1 and 2 (DTSA1 and DTSA2) | 31-71 |
| 31.17.2.5 | Data Trace End Address Registers 1 and 2 (DTEA1 and DTEA2) | 31-72 |
| 31.17.2.6 | Breakpoint / Watchpoint Control Register 1 (BWC1) | 31-72 |
| 31.17.2.7 | Breakpoint / Watchpoint Control Register 2 (BWC2) | 31-73 |
| 31.17.2.8 | Breakpoint/Watchpoint Address Registers 1 and 2 (BWA1 and BWA2) | 31-74 |
| 31.17.2.9 | Unimplemented Registers | 31-74 |
| 31.17.2.10 | Programming Considerations (RESET) | 31-74 |
| 31.17.2.11 | IEEE 1149.1 (JTAG) Test Access Port | 31-74 |
| 31.17.3 | Functional Description | 31-76 |
| 31.17.4 | Enabling NXDM and NXFR Operation | 31-76 |
| 31.17.5 | TCODEs Supported by NXDM and NXFR | 31-77 |
| 31.17.5.1 | Data Trace | 31-79 |

| | |
|--|-------|
| 31.17.5.2 Data Trace Messaging (DTM) | 31-79 |
| 31.17.5.3 DTM Message Formats | 31-79 |
| 31.17.5.4 DTM Operation | 31-81 |
| 31.17.5.5 Data Trace Timing Diagrams (Eight MDO configuration) | 31-82 |
| 31.17.6 Watchpoint Support | 31-82 |
| 31.17.6.1 Watchpoint Messaging | 31-83 |
| 31.17.6.2 Watchpoint Error Message | 31-83 |

Chapter 32

IEEE 1149.1 Test Access Port Controller (JTAGC)

| | |
|---|-------|
| 32.1 Introduction | 32-1 |
| 32.1.1 Block Diagram | 32-1 |
| 32.1.2 Overview | 32-2 |
| 32.1.3 Features | 32-2 |
| 32.1.4 Modes of Operation | 32-2 |
| 32.1.4.1 Reset | 32-2 |
| 32.1.4.2 IEEE 1149.1-2001 Defined Test Modes | 32-2 |
| 32.1.4.3 Bypass Mode | 32-3 |
| 32.1.4.4 TAP Sharing Mode | 32-3 |
| 32.2 External Signal Description | 32-4 |
| 32.3 Memory Map/Register Definition | 32-4 |
| 32.3.1 Instruction Register | 32-4 |
| 32.3.2 Bypass Register | 32-5 |
| 32.3.3 Device Identification Register | 32-5 |
| 32.3.4 CENSOR_CTRL Register | 32-5 |
| 32.3.5 Boundary Scan Register | 32-6 |
| 32.4 Functional Description | 32-6 |
| 32.4.1 JTAGC Reset Configuration | 32-6 |
| 32.4.2 IEEE 1149.1-2001 (JTAG) Test Access Port | 32-6 |
| 32.4.3 TAP Controller State Machine | 32-6 |
| 32.4.3.1 Enabling the TAP Controller | 32-9 |
| 32.4.3.2 Selecting an IEEE 1149.1-2001 Register | 32-9 |
| 32.4.4 JTAGC Instructions | 32-9 |
| 32.4.4.1 BYPASS Instruction | 32-10 |
| 32.4.4.2 ACCESS_AUX_TAP_x Instructions | 32-10 |
| 32.4.4.3 CLAMP Instruction | 32-10 |
| 32.4.4.4 EXTEST — External Test Instruction | 32-10 |
| 32.4.4.5 ENABLE_CENSOR_CTRL Instruction | 32-11 |
| 32.4.4.6 HIGHZ Instruction | 32-11 |
| 32.4.4.7 IDCODE Instruction | 32-11 |
| 32.4.4.8 SAMPLE Instruction | 32-11 |
| 32.4.4.9 SAMPLE/PRELOAD Instruction | 32-11 |
| 32.4.5 Boundary Scan | 32-12 |
| 32.5 Initialization/Application Information | 32-12 |

Chapter 33

Device Performance Optimization

| | |
|--|------|
| 33.1 Introduction | 33-1 |
| 33.2 Features | 33-1 |
| 33.3 Configuring Hardware Features | 33-2 |
| 33.3.1 Branch Target Buffer (BTB) | 33-2 |
| 33.3.1.1 Description | 33-2 |
| 33.3.1.2 Recommended Configuration | 33-2 |
| 33.3.2 Frequency Modulated PLL | 33-4 |
| 33.3.2.1 Description | 33-4 |
| 33.3.2.2 Recommended configuration | 33-4 |
| 33.3.3 Flash Bus Interface Unit | 33-4 |
| 33.3.3.1 Description | 33-4 |
| 33.3.3.2 Recommended configuration | 33-4 |
| 33.3.4 Crossbar Switch | 33-5 |

| | |
|---|-------|
| 33.3.4.1 Description | 33-5 |
| 33.3.4.2 Recommended Configuration | 33-5 |
| 33.3.5 Cache | 33-6 |
| 33.3.5.1 Description | 33-6 |
| 33.3.5.2 Recommended configuration | 33-6 |
| 33.3.6 Memory Management Unit (MMU) | 33-9 |
| 33.3.6.1 Description | 33-9 |
| 33.4 Application Software | 33-10 |
| 33.4.1 Compiler Optimizations | 33-10 |
| 33.4.2 Signal Processing Extension | 33-12 |
| 33.4.3 Hardware Single Precision Floating Point | 33-13 |
| 33.4.4 Variable Length Encoding | 33-13 |
| 33.5 Peripherals and General Application Guidelines | 33-14 |
| 33.6 Performance Optimization Checklist | 33-14 |

Chapter 34 Temperature Sensor

| | |
|---|------|
| 34.1 Overview | 34-1 |
| 34.2 Detailed Description | 34-1 |
| 34.3 Temperature formula | 34-3 |
| 34.3.1 T_{LOW} and T_{HIGH} | 34-3 |
| 34.3.2 $T_{TSENS_CODE}(T_{LOW})$ and $T_{TSENS_CODE}(T_{HIGH})$ | 34-3 |
| 34.3.3 $V_{BG_CODE}(T_{LOW})$ | 34-4 |
| 34.3.4 Temperature sensor voltage ($V_{TENS}(T)$) | 34-4 |
| 34.3.5 Bandgap reference voltage ($V_{BG_CODE}(T)$) | 34-4 |
| 34.3.6 Registers | 34-4 |
| 34.3.6.1 Temperature Calculation Constants Register 0 | 34-4 |
| 34.3.6.2 Temperature Calculation Constants Register 1 | 34-5 |

Appendix A Revision History of this Document

About This Book

This reference manual describes the PXR40 processor for software and hardware developers. Information regarding bus timing, signal behavior, and AC, DC, and thermal characteristics are detailed in the device data sheet (*PXR40 Microcontroller Data Sheet*).

The information in this book is subject to change without notice, as described in the disclaimers on the title page. As with any technical documentation, the reader needs to make sure to use the most recent version of the documentation.

To locate any published errata or updates for this document, refer to the world-wide web at <http://www.freescale.com/powerpc>.

Audience

This manual is intended for system software and hardware developers and applications programmers who want to develop products with the PXR40 processor. It is assumed that the reader understands operating systems, microprocessor system design, basic principles of software and hardware, and basic details of the Power Architecture[®] architecture.

Organization

This document includes chapters that describe:

- The microcontroller as a whole
- The functionality of the individual modules on the microcontroller

When the microcontroller is specified as “PXR40,” the reader is instructed to apply this information to all of the microcontrollers specified on the front cover of this manual, unless individual device-specific details are provided in that chapter.

The following summary provides a brief description of the major sections of this manual:

- [Chapter 1, Introduction](#), includes general descriptions of the modules and features incorporated in the device while focusing on new features.
- [Chapter 2, Memory Map](#), provides a high-level listing of the PXR40 memory map.
- [Chapter 3, Signal Descriptions](#), summarizes the external signal functions, their static electrical characteristics, and pad configuration settings for the PXR40.
- [Chapter 4, Resets](#), describes the reset sources available on the PXR40, including details on status flags and default configurations.
- [Chapter 5, Power Management Controller \(PMC\)](#), describes the on-chip module that provides voltage regulation for the PXR40.
- [Chapter 6, Frequency Modulated Phase-Locked Loop \(FMPLL\)](#), describes the features and function of the FMPLL module.

- [Chapter 7, System Integration Unit \(SIU\)](#), describes the SIU module, which controls MCU reset configuration, pad configuration, external interrupt, general-purpose I/O (GPIO), internal peripheral multiplexing, and the system reset operation.
- [Chapter 8, System Information Module](#), describes the System Information Module (SIM), which contains the temperature sensor calibration constants and a unique 128-bit Device ID number.
- [Chapter 9, Boot Assist Module \(BAM\)](#), describes the BAM, which contains the MCU boot program code supporting the different booting modes for this device.
- [Chapter 10, Interrupts and Interrupt Controller \(INTC\)](#), summarizes the software and hardware interrupts for the PXR40 device.
- [Chapter 11, General-Purpose Static RAM \(SRAM\)](#), describes the on-chip static RAM (SRAM) implementation, covers general operations, configuration, and initialization. It also provides information and examples of how to minimize power consumption when using the SRAM.
- [Chapter 12, Flash Memory Array and Control](#), describes the flash memory block and the flash memory controller.
- [Chapter 13, Core \(e200z7\) Overview](#), describes the organization of the e200z7 Power processor core and gives an overview of the programming models as they are implemented on the device. The e200z7 is the main processor core on the PXR40.
- [Chapter 14, AMBA Crossbar Switch \(XBAR\)](#), describes the multi-port AXBS crossbar switch that supports simultaneous connections between the master and slave ports.
- [Chapter 15, Peripheral Bridge \(PBRIDGE\)](#), describes the interface between the system bus and lower bandwidth peripherals via the AIPS bridge.
- [Chapter 16, Memory Protection Unit \(MPU\)](#), describes the block that provides hardware access control for all memory references generated in the PXR40.
- [Chapter 17, Error Correction Status Module \(ECSM\)](#), describes the ECSM block, which provides monitoring and control functions to report memory errors and apply error-correcting code (ECC) implementations.
- [Chapter 18, Software Watchdog Timer \(SWT\)](#), describes a hardware-based timer that can be implemented to prevent software runaway.
- [Chapter 19, System Timer Module \(STM\)](#), describes the timer control module.
- [Chapter 20, Periodic Interrupt Timer \(PIT_RTI\)](#), describes an array of timers that can be used to initiate interrupts and trigger DMA channels.
- [Chapter 21, Enhanced Direct Memory Access Controller \(eDMA\)](#), describes the enhanced DMA controller implemented on the PXR40.
- [Chapter 22, FlexRay Communication Controller \(FLEXRAY\)](#), describes the FlexRay communication controller on the PXR40 that implements the *FlexRay Communications System Protocol Specification, Version 2.1 Rev A*.
- [Chapter 23, Enhanced Modular Input/Output Subsystem \(eMIOS200\)](#), describes the eMIOS module, which provides timed I/O channels for communications with off-chip devices.
- [Chapter 24, FlexCAN Module](#), describes the FlexCAN module, a communication controller implementing the CAN protocol according to Bosch Specification version 2.0B and ISO Standard 11898.

- [Chapter 25, Deserial Serial Peripheral Interface \(DSPI\)](#), describes the serial peripheral interface (SPI) block, which provides a synchronous serial interface for communication between the PXR40 and external devices.
- [Chapter 26, Enhanced Serial Communication Interface \(eSCI\)](#), describes the eSCI interface, which allows asynchronous serial communications with off-chip peripheral devices.
- [Chapter 27, Enhanced Queued Analog-to-Digital Converter \(EQADC\)](#),
- [Chapter 28, Decimation Filter](#), describes the 12 on-chip modules that contain a multiply-accumulate (MAC) unit capable of implementing a 16-bit, 4th order IIR or 8th order FIR filter.
- [Chapter 29, Enhanced Time Processing Unit \(eTPU2\)](#), describes the co-processor designed for timing control.
- [Chapter 30, External Bus Interface \(EBI\)](#), describes the module that handles the transfer of information between the internal buses and the memories or peripherals in the external address space.
- [Chapter 31, Nexus Development Interface \(NDI\)](#), describes the Nexus Development Interface (NDI) block, which provides real-time development support capabilities for the PXR40 in compliance with the IEEE-ISTO 5001-2003 standard.
- [Chapter 32, IEEE 1149.1 Test Access Port Controller \(JTAGC\)](#), describes configuration and operation of the Joint Test Action Group (JTAG) controller implementation. It describes those items required by the IEEE® 1149.1 standard and provides additional information specific to the device. For internal details and sample applications, see the IEEE 1149.1 document.
- [Chapter 33, Device Performance Optimization](#), describes how to improve the overall level of performance provided by the device.
- [Chapter 34, Temperature Sensor](#), describes the on-board sensor that monitors device temperature.
- [Appendix A, Revision History of this Document](#), describes the revision history of this document.

Suggested reading

This section lists additional reading that provides background for the information in this manual as well as general information about PowerPC architecture.

General information

Useful information about the PowerPC architecture and computer architecture in general:

- *Programming Environments Manual for 32-Bit Implementations of the PowerPC™ Architecture* (MPCFPE32B)
- *Using Microprocessors and Microcomputers: The Motorola Family*, William C. Wray, Ross Bannatyne, Joseph D. Greenfield
- *Computer Architecture: A Quantitative Approach*, Second Edition, by John L. Hennessy and David A. Patterson.

- *Computer Organization and Design: The Hardware/Software Interface*, Second Edition, David A. Patterson and John L. Hennessy.

Power Architecture documentation

Power Architecture documentation is available from the sources listed on the back cover of this manual, as well as our web site, <http://www.freescale.com/powerpc>.

- Reference manuals (formerly called user's manuals)—These books provide details about individual PowerPC implementations and are intended to be used in conjunction with the *PowerPC Programmers Reference Manual*.
- Addenda/errata to reference manuals—Because some processors have follow-on parts, an addendum is provided that describes the additional features and functionality changes. Also, if mistakes are found within a reference manual, an errata document may be issued before the next published release of the reference manual. These addenda/errata are intended for use with the corresponding reference manuals.
- Data sheets—Data sheets provide specific information regarding pin-out diagrams, bus timing, signal behavior, and AC, DC, and thermal characteristics, as well as other design considerations.
- Product briefs—Each device has a product brief that provides an overview of its features. This document is roughly equivalent to the overview (Chapter 1) of a device's reference manual.
- Application notes—These short documents address specific design issues useful to programmers and engineers working with Freescale Semiconductor processors.

Additional literature is published as new processors become available. For a current list of PowerPC documentation, refer to <http://www.freescale.com/powerpc>.

Conventions

This document uses the following notational conventions:

| | |
|----------------|--|
| cleared/set | When a bit takes the value zero, it is said to be cleared; when it takes a value of one, it is said to be set. |
| reserved | When a bit or address is reserved, it should not be written. If read, its value cannot be not guaranteed. Reading or writing to reserved bits or addresses may cause unexpected results. |
| MNEMONICS | In text, instruction mnemonics are shown in uppercase. |
| mnemonics | In code and tables, instruction mnemonics are shown in lowercase. |
| <i>italics</i> | Italics indicate variable command parameters. Book titles in text are set in italics. |
| 0x0 | Prefix to denote hexadecimal number |
| 0b0 | Prefix to denote binary number |
| REG[FIELD] | Abbreviations for registers are shown in uppercase. Specific bits, fields, or ranges appear in brackets. For example, RAMBAR[BA] identifies the base address field in the RAM base address register. |

| | |
|----------------|--|
| nibble | A 4-bit data unit |
| byte | An 8-bit data unit |
| halfword | A 16-bit data unit ¹ |
| word | A 32-bit data unit |
| doubleword | A 64-bit data unit |
| x | In some contexts, such as signal encodings, x (without italics) indicates a “don’t care” condition. |
| <i>x</i> | With italics, used to express an undefined alphanumeric value (e.g., a variable in an equation); or a variable alphabetic character in a bit, register, or module name (e.g., DSPI_ <i>x</i> could refer to DSPI_A or DSPI_B). |
| <i>n</i> | Used to express an undefined numerical value; or a variable numeric character in a bit, register, or module name (e.g., EIF <i>n</i> could refer to EIF1 or EIF0). |
| ~ | NOT logical operator |
| & | AND logical operator |
| | OR logical operator |
| | Field concatenation operator |
| <u>OVERBAR</u> | An overbar indicates that a signal is active-low. |

Register Figure Conventions

This document uses the following conventions for the register reset values:

| | |
|------------------------|--|
| w1c | Write 1 to clear the bit to 0. |
| — | Undefined at reset or “not applicable.” |
| U | Bit value is uninitialized upon reset. |
| u | Bit value is unchanged upon reset. |
| [<i>signal_name</i>] | Reset value is determined by the polarity of the indicated signal. |

The following register fields are used:

| | | |
|---|---|--|
| R | 0 | Indicates a reserved bit field in a memory-mapped register. These bits are always read as zeros. |
| W | | |

| | | |
|---|---|---|
| R | 1 | Indicates a reserved bit field in a memory-mapped register. These bits are always read as ones. |
| W | | |

| | | |
|---|-----------|-----------------------------|
| R | FIELDNAME | Indicates a read/write bit. |
| W | | |

¹The only exceptions to this appear in the discussion of serial communication modules that support variable-length data transmission units. To simplify the discussion these units are referred to as words regardless of length.

| | | |
|---|-----------|---|
| R | FIELDNAME | Indicates a read-only bit field in a memory-mapped register. |
| W | | |
| R | | Indicates a write-only bit field in a memory-mapped register. |
| W | FIELDNAME | |
| R | FIELDNAME | Write 1 to clear: indicates that writing a 1 to this bit field clears it. |
| W | w1c | |
| R | 0 | Indicates a self-clearing bit. |
| W | FIELDNAME | |

Acronyms and Abbreviations

Table i lists acronyms and abbreviations used in this document.

Table i. Acronyms and Abbreviated Terms

| Term | Meaning |
|-------|--|
| ADC | Analog-to-digital conversion |
| ALU | Arithmetic logic unit |
| BDM | Background debug mode |
| BIST | Built-in self test |
| BSDL | Boundary-scan description language |
| CODEC | Code/decode |
| DAC | Digital-to-analog conversion |
| DMA | Direct memory access |
| DSP | Digital signal processing |
| EA | Effective address |
| FIFO | First-in, first-out |
| GPIO | General-purpose I/O |
| IEEE | Institute for Electrical and Electronics Engineers |
| IFP | Instruction fetch pipeline |
| IPL | Interrupt priority level |
| JEDEC | Joint Electron Device Engineering Council |
| JTAG | Joint Test Action Group |
| LIFO | Last-in, first-out |
| LRU | Least recently used |
| LSB | Least-significant byte |
| lsb | Least-significant bit |

Table i. Acronyms and Abbreviated Terms (continued)

| Term | Meaning |
|-------------|---|
| MAC | Multiply accumulate unit, also Media access controller |
| MSB | Most-significant byte |
| msb | Most-significant bit |
| Mux | Multiplex |
| NC | No connection |
| NOP | No operation |
| OEP | Operand execution pipeline |
| PC | Program counter |
| PLIC | Physical layer interface controller |
| PLL | Phase-locked loop |
| PIN | Referring to an external pin or ball (i.e. external signal) |
| POR | Power-on reset |
| RISC | Reduced instruction set computing |
| Rx | Receive |
| SOF | Start of frame |
| STAC | Shared Time and Counter |
| TAP | Test access port |
| TTL | Transistor transistor logic |
| Tx | Transmit |
| UART | Universal asynchronous/synchronous receiver transmitter |
| USB | Universal serial bus |

Terminology conventions

[Table ii](#) shows terminology conventions used throughout this document.

Table ii. Notational Conventions

| Instruction | Operand Syntax |
|------------------------|---|
| Opcode Wildcard | |
| cc | Logical condition (example: NE for not equal) |

Table ii. Notational Conventions (continued)

| Instruction | Operand Syntax |
|--------------------------------|---|
| Register Specifications | |
| An | Any address register n (example: A3 is address register 3) |
| Ay,Ax | Source and destination address registers, respectively |
| Dn | Any data register n (example: D5 is data register 5) |
| Dy,Dx | Source and destination data registers, respectively |
| Rc | Any control register (example VBR is the vector base register) |
| Rm | MAC registers (ACC, MAC, MASK) |
| Rn | Any address or data register |
| Rw | Destination register w (used for MAC instructions only) |
| Ry,Rx | Any source and destination registers, respectively |
| Xi | Index register i (can be an address or data register: Ai, Di) |
| Miscellaneous Operands | |
| #<data> | Immediate data following the 16-bit operation word of the instruction |
| <ea> | Effective address |
| <ea>y,<ea>x | Source and destination effective addresses, respectively |
| <label> | Assembly language program label |
| <list> | List of registers for MOVEM instruction (example: D3–D0) |
| <shift> | Shift operation: shift left (<<), shift right (>>) |
| <size> | Operand data size: byte (B), word (W), longword (L) |
| bc | Instruction and data caches |
| dc | Data cache |
| ic | Instruction cache |
| # <vector> | Identifies the 4-bit vector number for trap instructions |
| <> | identifies an indirect data address referencing memory |
| <xxx> | identifies an absolute address referencing memory |
| d <i>n</i> | Signal displacement value, <i>n</i> bits wide (example: d16 is a 16-bit displacement) |
| SF | Scale factor (x1, x2, x4 for indexed addressing mode, <<1 <i>n</i> >> for MAC operations) |
| Operations | |
| + | Arithmetic addition or postincrement indicator |
| – | Arithmetic subtraction or predecrement indicator |
| x | Arithmetic multiplication |

Table ii. Notational Conventions (continued)

| Instruction | Operand Syntax |
|--|---|
| / | Arithmetic division |
| ~ | Invert; operand is logically complemented |
| & | Logical AND |
| | Logical OR |
| ^ | Logical exclusive OR |
| << | Shift left (example: D0 << 3 is shift D0 left 3 bits) |
| >> | Shift right (example: D0 >> 3 is shift D0 right 3 bits) |
| → | Source operand is moved to destination operand |
| ↔ | Two operands are exchanged |
| sign-extended | All bits of the upper portion are made equal to the high-order bit of the lower portion |
| If <condition> then <operations> else <operations> | Test the condition. If true, the operations after then are performed. If the condition is false and the optional else clause is present, the operations after else are performed. If the condition is false and else is omitted, the instruction performs no operation. Refer to the Bcc instruction description as an example. |
| Subfields and Qualifiers | |
| {} | Optional operation |
| () | Identifies an indirect address |
| d_n | Displacement value, n-bits wide (example: d_{16} is a 16-bit displacement) |
| Address | Calculated effective address (pointer) |
| Bit | Bit selection (example: Bit 3 of D0) |
| lsb | Least significant bit (example: lsb of D0) |
| LSB | Least significant byte |
| LSW | Least significant word |
| msb | Most significant bit |
| MSB | Most significant byte |
| MSW | Most significant word |

Chapter 1

Introduction

The PXR40 device targets real-time, high performance applications. It is built upon the 90 nm CMOS technology node. This document describes the features of the PXR40 and highlights important electrical and physical characteristics of the device.

The e200z7 core of the PXR40 is compatible with the Power Architecture® Book E architecture. It is 100% user-mode compatible (with floating point library) with the classic PowerPC instruction set. The Book E architecture has enhancements that improve the architecture's fit in embedded applications. In addition to the classic PowerPC instruction set, this core also has additional instruction support for digital signal processing (DSP) and SIMD operations.

The PXR40 has two levels of memory hierarchy, a 32 KB Harvard architecture cache and a 256 KB on-chip SRAM. 4 MB of internal flash memory is provided.

The features of the final, production-targeted device version are listed below.

1.1 PXR40 features

Table 1-1 shows the PXR40 feature set.

Table 1-1. PXR40 feature set

| Feature | PXR40 |
|------------------------------|---|
| Core | e200z7 |
| SIMD | Yes |
| VLE | Yes |
| Cache | 32 KB (16 KB Instruction/16 KB Data) |
| Non-maskable interrupt (NMI) | NMI & Critical Interrupt |
| MMU | 64 entry |
| MPU | Yes |
| XBAR | 5 × 5 |
| Windowing software watchdog | Yes |
| Nexus | 3+ |
| SRAM | 256 KB |
| Flash | 4 MB |
| Flash fetch accelerator | 4 × 256 bit (first 1 MB of memory is 4 × 128; last 3 MB are 4 × 256) |
| External bus | Yes |
| Calibration bus | 16 bit non-muxed 32 bit muxed |
| DMA | 96 channel |
| DMA Nexus | Class 3 |

Table 1-1. PXR40 feature set (continued)

| Feature | PXR40 |
|------------------------|-----------------------------------|
| Serial | 3 |
| UART_A | Yes |
| UART_B | Yes |
| UART_C | Yes |
| Microsecond bus uplink | Yes |
| CAN | 4 |
| CAN_A | 64 message buffers |
| CAN_B | 64 message buffers |
| CAN_C | 64 message buffers |
| CAN_D | 64 message buffers |
| CAN_E | No |
| SPI | 4 |
| SPI_A | Yes |
| SPI_B | Yes |
| SPI_C | Yes |
| SPI_D | Yes |
| FlexRay | Yes |
| Ethernet | No |
| System timers | 4 PIT chan 4 SWT 1 Watchdog |
| eMIOS | 32 channel |
| eTPU | 64 channel |
| eTPU_A | Yes (eTPU2) |
| eTPU_B | Yes (eTPU2) |
| Code memory | 24 KB |
| Data memory | 6 KB |
| Interrupt controller | 448 |
| ADC | 64 channel |
| eQADC_A | Yes |
| eQADC_B | Yes |
| Temperature sensor | Yes |
| Variable gain amp. | Yes |
| Decimation filter | Yes (8 on eQADC_B) |
| Sensor diagnostics | Yes |
| PLL | FM |
| VRC | Yes |
| Supplies | 5V |
| Low Power Modes | Stop Mode Slow Mode |

Note: 3.3 V is required for certain IO segments only during debug/development (e.g., Nexus 3 trace and bus)

1.1.1 Block diagram

Figure 1-1 shows a top-level block diagram of the PXR40.

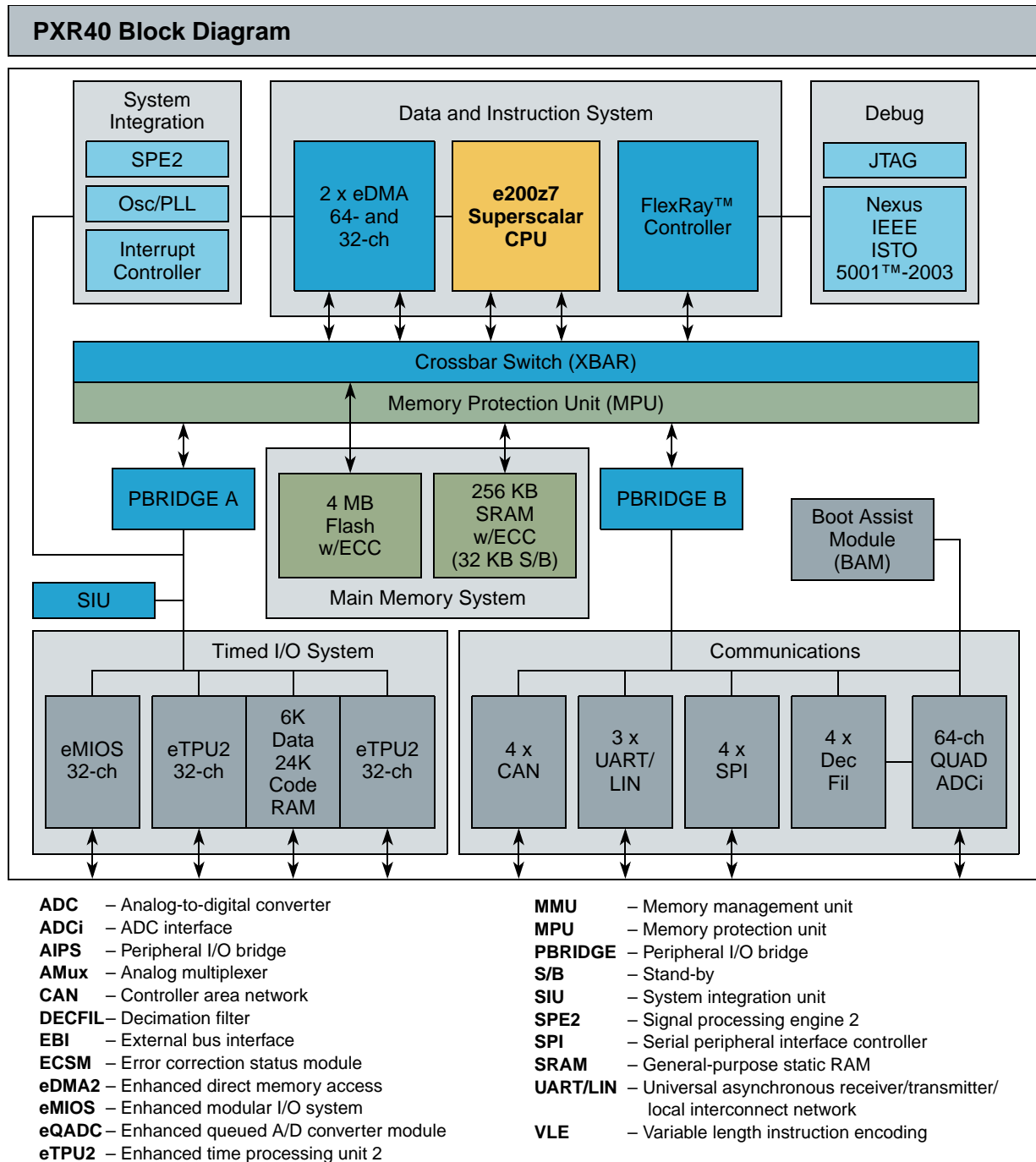

Figure 1-1. PXR40 block diagram

1.1.2 Critical Performance Parameters

The critical performance parameters of the PXR40 feature the following:

- Maximum CPU frequency: 264 MHz
 - Platform and peripheral modules typically run at half of the CPU frequency
 - Some peripheral modules (including the eTPU modules) support a full frequency mode with a maximum operating frequency of 200 MHz
- Temperature range: -40° to 105° C
- Nominal power dissipation is less than 1.4 W, while enhancements to allow reduced power operation using clock gating are included
- Separate power supply available for stand-by operation of a portion of SRAM

1.1.3 Low-power modes

The PXR40 includes two special modes to allow reduction of application power consumption:

- Slow mode: Allows the device to be run at very low speed (approximately 1 MHz), with modules (including the PLL) selectively disabled by software.
- Stop mode: System clock stopped to most modules including the CPU. Wake-up timer used to restart the system clock after a predetermined time.

1.2 Packages

The PXR40 is offered in a 416-ball PBGA, 1 mm ball pitch, 27 mm \times 27 mm outline (no EBI) package type.

1.2.1 Chip-level features

On-chip modules available within the family include the following features:

- Dual issue, 32-bit CPU core complex (e200z7)
 - Compliant with the Power Architecture embedded category
 - 16 KB I-Cache and 16 KB D-Cache
 - Includes an instruction set enhancement allowing variable length encoding (VLE), optional encoding of mixed 16-bit and 32-bit instructions, for code size footprint reduction
 - Includes signal processing extension (SPE2) instruction support for digital signal processing (DSP) and single-precision floating point operations
- 4 MB on-chip flash
 - Supports read during program and erase operations, and multiple blocks allowing EEPROM emulation
- 256 KB on-chip general-purpose SRAM including 32 KB of standby RAM
- Two direct memory access controller (eDMA2) blocks
 - One supporting 64 channels

- One supporting 32 channels
- Interrupt controller (INTC)
- Phase-locked loop with FM modulation (FMPLL)
- Crossbar switch architecture for concurrent access to peripherals, flash, or RAM from multiple bus masters
- External bus interface (EBI) for calibration and application development
- System integration unit (SIU)
- Error correction status module (ECSM)
- Boot assist module (BAM) supports serial bootload via CAN or SCI
- Two second-generation enhanced time processor units (eTPU2)
 - 32 standard channels per eTPU2
 - 24 KB code RAM
 - 6 KB parameter RAM
- Enhanced modular input output system supporting 32 unified channels (eMIOS) with each channel capable of single action, double action, pulse width modulation (PWM) and modulus counter operation
- Two enhanced queued analog-to-digital converters (eQADC)
 - Support for 64 analog channels
 - Includes one absolute reference ADC channel
 - Includes eight decimation filters (connected to eQADC_B)
- Four deserial serial peripheral interface (DSPI) modules
- Three enhanced serial communication interface (eSCI) modules
- Four controller area network (FlexCAN) modules
- Dual-channel FlexRay controller
- Nexus development interface (NDI) per IEEE-ISTO 5001-2011 standard
- Device and board test support per Joint Test Action Group (JTAG) (IEEE 1149.1)
- On-chip voltage regulator controller regulates supply voltage down to 1.2 V for core logic
- On-chip voltage regulator down to 3.3 V for PLL, flash, and I/O pre-driver logic

1.2.2 Module features

The following sections provide more details of the modules implemented on the PXR40.

1.2.3 High-performance e200z7 core processor

The e200z7 core includes the following features:

- Dual-issue, 32-bit Power Architecture[®] CPU
- Supports the 32-bit Power Architecture Book E programmer's model

- 64-bit general-purpose registers (GPRs) support vector instructions defined by the SPE2 APU
 - All arithmetic instructions that execute in the core operate on data in the GPRs
- Enhanced signal processing extension (SPE2) APU supports real-time fixed point and single-precision embedded numerics operations using the GPRs
- Variable length encoding (VLE) enhancements
 - Allows optional encoding of mixed 16-bit and 32-bit instructions
 - Results in smaller code size footprint
 - Minimizes impact on performance
- Six read and three write operations per clock
 - Integrates a pair of integer execution units, a branch control unit, instruction fetch unit and load/store unit, and a multi-ported register file
- Branch target prefetching performed by the branch unit allows single-cycle branches in many cases
- 16 KB instruction cache and 16 KB data cache, both supporting error detection hardware.
- Memory management unit (MMU) with 64-entry fully-associative translation look-aside buffer (TLB)
- Nexus Class 3+ module
- Supports non-maskable interrupt (completely un-maskable and not guaranteed to be recoverable) and critical interrupt (an interrupt that can be masked and is guaranteed to be recoverable) sources
 - Routed from a single package pin, via edge detection logic in the SIU, to the CPU
- An additional Wait for Interrupt instruction:
 - Used in conjunction with low power STOP mode
 - Instruction stops the system clock
 - An external interrupt source or the system wake-up timer restart the system clock, allowing the CPU to service the interrupt
- Includes multiple input signature register (MISR) hardware which can be accessed by software to implement CPU self test functionality

1.2.4 On-chip flash memory

The PXR40 flash memory module provides the following:

- 4 MB of programmable, non-volatile, flash memory
 - Nonvolatile memory (NVM) can be used for instruction and/or data storage
- A fetch accelerator optimizes the performance of the flash memory array to match the CPU architecture
 - Architected to optimize the performance of the flash memory with the CPU to provide single-cycle random access to the flash memory when in full clock mode, and two-cycle access when in double clock mode
 - Configurable read buffering and line prefetch support
- An interface between the system bus and a dedicated flash memory array controller

- Supports a 64-bit data bus width at the system bus port for CPU loads, DMA transfers and CPU instruction fetch
 - Byte, halfword, word, and doubleword reads are supported
 - Only aligned word and doubleword writes are supported
- Hardware and software configurable read and write access protections on a per-master basis
- Pipelined interface to the flash memory array controller allowing overlapped accesses to proceed in parallel for interleaved or pipelined flash memory array designs
- Configurable access timing allowing use in a wide range of system frequencies
- Multiple-mapping support and mapping-based block access timing (0–31 additional cycles) allowing use for emulation of other memory types
- Software programmable block program/erase restriction control
- ECC with single-bit correction, double-bit detection
- Minimum program size is two consecutive 32-bit words, aligned on a 0-modulo-8 byte address (due to ECC)
- Embedded hardware program and erase algorithm
- Erase suspend, program suspend and erase-suspended program
- Shadow information stored in non-volatile shadow block
- Independent program/erase of the shadow block

1.2.5 General-purpose static RAM (SRAM)

The PXR40 SRAM module provides an internal general-purpose 256 KB memory block. The SRAM controller includes these features:

- Supports read/write accesses mapped to the SRAM memory from any master
- 32 KB block powered by separate supply for standby operation (contents retained)
- Byte, halfword, word, and doubleword addressable
- ECC performs single-bit correction, double-bit detection on 64-bit data elements
- ECC single-bit error corrections are optionally visible to software

1.2.6 Error correction status module (ECSM)

The error correction status module (ECSM) provides the following:

- Status information regarding platform memory errors reported by error detection code (EDC) and error correcting code (ECC) hardware
 - Single-bit correction reporting for SRAM and flash memory
 - Multi-bit error reporting
- Includes facilities to allow CPU software to test the error ECC and EDC operation for on-chip memories by supporting injection of arbitrary error patterns

1.2.7 Enhanced modular input output system (Timer—eMIOS)

The eMIOS module provides the functionality to generate or measure time events. A unified channel (UC) module is employed that provides a superset of the functionality of all of the MIOS channels used on MPC5500 family devices, while providing a consistent user interface. This allows more flexibility as each unified channel can be programmed for different functions in different applications. To identify as many as two timed events, each UC contains two comparators, a time base selector and registers. This structure is able to produce match-events, which can be configured to measure or generate a waveform. Alternatively, input events can be used to capture the time base, allowing measurement of an input signal. The eMIOS provides the following features:

- 32 unified channels, featuring:
 - 24-bit registers for capture/match values
 - 24-bit internal counter
 - Global prescaler
 - Pin for input/output (each channel signal is routed to a pin, however, most pins are also multiplexed with other signals)
 - Selectable time base
 - Can generate its own time base
- Five 24-bit wide counter buses
 - Counter bus A can be driven by unified channel 23
 - Counter bus B, C, D and E are driven by unified channels 0, 8, 16, and 24, respectively
 - Counter bus A can be shared among all unified channels. UCs 0 to 7, 8 to 15, 16 to 23, and 24 to 31 can share counter buses B, C, D and E, respectively
- Shared time bases with the eTPU
- Synchronization among internal and external time bases
- Shadow FLAG register
- State of block can be frozen for debug purposes

1.2.8 Enhanced timing processor unit (eTPU2)

Two eTPU2 modules are available on the PXR40. The eTPU2 is the second generation of the enhanced timing co-processors (eTPU) that were used on the MPC5500 family. eTPU2 is fully upward compatible with eTPU, runs the same binary code image, and can be used with the same tool suite. eTPU2 includes many enhancements to improve efficiency of compilers, functionality, ease of programming and operability while maintaining the same overall architecture. Some of these enhancements may be accessed using the existing compiler tool chain, while other enhancements require updates to the compiler.

The eTPU2 includes these distinctive features:

- 32 standard channels, each channel is associated with one input and one output signal
- Two independent 24-bit time bases for channel synchronization:
- Event-triggered microengine
 - 24 KB of code memory (SCM)

- 6 KB of shared parameter (data) RAM (SPRAM)
- Resource sharing features support channel use of common channel registers, memory and microengine time
 - Hardware scheduler works as a task management unit, dispatching event service routines by pre-defined, host-configured priority
 - Channel context switch time is six system cycles. Each channel has its own context of static data memory and timer hardware resources consisting of programmable flags, timer control and status hardware
 - SPRAM shared between host CPU and eTPU, supporting communication either between channels and host or inter-channel
 - Dual-parameter coherency hardware support allows atomic access to two parameters by host
 - Enhancements to DMA and interrupt structure to allow any channel to assert any interrupt source or DMA trigger¹
- Test and development support features:
 - IEEE-ISTO 5001-2003 standard class 3 compliant for the eTPU (Nexus)
 - Data trace via data write messaging and data read messaging
 - Ownership trace via ownership trace messaging (OTM)
 - Program trace via branch trace messaging
 - Watchpoint messaging via the auxiliary port
 - SCM continuous signature-check built-in self test (MISC — multiple input signature calculator), runs concurrently with eTPU normal operation

1.2.9 Software watchdog timer (SWT)

The software watchdog timer (SWT) is a second watchdog module to complement the standard Power Architecture watchdog integrated in the CPU core. When enabled, the SWT requires periodic execution of a watchdog servicing sequence. Writing the sequence resets the timer to a specified time-out period. If this servicing action does not occur before the timer expires the SWT generates an interrupt or hardware reset. The SWT can be configured to generate a reset or interrupt on an initial time-out, a reset is always generated on a second consecutive time-out.

The following features are implemented:

- 32-bit time-out register to set the time-out period
- Programmable selection of system or oscillator clock for timer operation
- Programmable selection of window mode or regular servicing
- Programmable selection of reset or interrupt on an initial time-out
- Master access protection
- Hard and soft configuration lock bits
- Reset configuration inputs allow timer to be enabled out of reset

1.2.10 Periodic interrupt timer (PIT)

The periodic interrupt timer (PIT) is an array of timers that can be used to generate interrupts and trigger DMA channels. It also provides a dedicated real-time interrupt timer (RTI), which runs on a separate clock and can be used for system wake-up.

The following features are implemented:

- Four independent timer channels
- Each channel includes 32-bit wide down counter with automatic reload
- Three channels clocked from system clock
- One channel clocked from crystal clock (wake-up timer)
- Wake-up timer remains active when system enters stop mode. Used to restart system clock after predefined time-out period
- Each channel can optionally generate interrupt request when timer reaches zero
- Channels can optionally produce trigger event when timer reaches zero (used to trigger eQADC queues)

1.2.11 System timer module (STM)

The system timer module (STM) is a 32-bit timer designed to support commonly required operating system and application software timing functions. The STM includes a 32-bit up counter and four 32-bit compare channels with a separate interrupt source for each channel.

The following features are implemented:

- One 32-bit up counter with 8-bit prescaler
- Four 32-bit compare channels
- Independent interrupt source for each channel
- Counter can be stopped in debug mode

1.2.12 Enhanced queued analog to digital converter (eQADC)

The enhanced queued analog to digital converter (eQADC) block provides accurate and fast conversions for a wide range of applications. The two eQADCs on the PXR40 provide a parallel interface to four on-chip analog to digital converters (ADC), and a single-master to single-slave serial interface to an off-chip external device.

The ADCs include features designed to allow the direct connection of high impedance acoustic sensors that might be used in a system for detecting engine knock. These features include differential inputs; integrated variable gain amplifiers for increasing the dynamic range; programmable pullup and pulldown resistors for biasing and sensor diagnostics.

eQADC_B also integrates four programmable decimation filters capable of taking in ADC conversion results at a high rate, passing them through a hardware low-pass filter, then down-sampling the output of the filter and feeding the lower sample rate results to the result FIFOs. This allows the ADCs to sample the sensor at a rate high enough to avoid aliasing of out-of-band noise, while providing a reduced sample

rate output to minimize the amount of DSP processing bandwidth required to fully process the digitized waveform.

The eQADCs provide the following features:

- Quad on-chip ADCs
 - $4 \times$ 12-bit ADC resolution
 - Programmable resolution for increased conversion speed (12-bit, 10-bit, 8-bit)
 - 12-bit conversion time as low as $1 \mu\text{s}$ (as fast as 1 M sample/sec)
 - 10-bit conversion time as low as 867 nS (as fast as 1.2 M sample/sec)
 - 8-bit conversion time as low as 733 nS (as fast as 1.4 M sample/sec)
 - Accuracy as high as 10-bit accuracy at 500 K sample/sec and 8-bit accuracy at 1 M sample/sec
 - Differential conversions
 - Single-ended signal range from 0 to 5 V
 - Variable gain amplifiers on differential inputs ($\times 1$, $\times 2$, $\times 4$)
 - Sample times of 2 (default), 8, 64, or 128 ADC clock cycles
 - Provides time stamp information when requested
 - Supports both right-justified unsigned and signed formats for conversion results
- 64 input channels, including 16 channels which can each be converted simultaneously by each eQADC
- Eight additional internal channels for measuring control and monitoring voltages inside the device
 - Including core voltage, I/O voltage, and low-voltage interrupt (LVI) voltages
- As many as eight inputs can be configured as four pairs of differential analog input channels
 - Programmable pull-up/pull-down resistors on each differential input
- Silicon die temperature sensor
 - Provides temperature of silicon as an analog value
 - Read using an internal ADC analog channel
- Four decimation filters
 - Programmable decimation factor (2 to 16)
 - Selectable IIR or FIR filter
 - Fully programmable 4th order IIR or 8th order FIR
 - Saturated or non-saturated modes
 - Programmable rounding (convergent; two's complement; truncated)
 - Pre-fill mode to pre-condition the filter before the sample window opens
- Full duplex synchronous serial interface to an external device
 - Free-running clock for use by an external device
 - Supports a 26-bit message length
- Six priority-based queues per ADC
- Trigger sources include software, timer channels and input pins

- eTPU result interface
 - Allows any ADC result to be exported to eTPU for use with reaction channels
- Support for an additional $64 - 8 = 56$ channels via external multiplexing

1.2.13 Serial peripheral interface module (SPI)

The PXR40 includes four serial peripheral interface (SPI) blocks that provide a synchronous serial interface for communication to external devices. The SPI features the following:

- Supports pin count reduction through serialization and deserialization of eTPU and eMIOS channels and memory-mapped registers
- Channels and register content are transmitted using a SPI protocol
 - The protocol is completely configurable for baud rate, polarity, phase, frame length, chip select assertion, etc.
 - Each bit in the frame may be configured to serialize either eTPU channels, eMIOS channels or GPIO signals
- Can be configured to serialize data to an external device that is compatible with the Microsecond Bus protocol
- SPI pins support 5 V logic levels or low voltage differential signalling (LVDS) to improve high-speed operation on data and clock signals

The SPIs have multiple configurations:

- Serial peripheral interface (SPI) configuration where the SPI operates as an up-to-16-bit SPI with support for queues
- Deserial serial interface (DSI) configuration where the SPI serializes as many as 32 bits from eTPU, eMIOS, or GPIO output channels and deserializes the received data by placing it on the eTPU, eMIOS, or GPIO input channels
- Combined serial interface (CSI) configuration where the SPI operates in both SPI and DSI configurations interleaving DSI frames with SPI frames, giving priority to SPI frames
- Enhanced deserial serial interface (DSI) configuration where SPI serializes as many as 32 bits with three possible sources per bit
 - eTPU, eMIOS, new virtual GPIO registers as possible bit source
 - Programmable inter-frame gap in continuous mode
 - Bit source selection allows microsecond bus downlink with command or data frames as large as 32 bits
 - Microsecond bus dual receiver mode

For queued operations, the SPI queues reside in system memory external to the SPI. Data transfers between the memory and the SPI FIFOs are accomplished through the use of the eDMA2 controller or through host software.

1.2.14 Serial communication interface module (UART)

The PXR40 includes three serial communications interface (UART) modules. Each UART allows asynchronous serial communications with peripheral devices and other MCUs. It includes special support to interface to local interconnect network (LIN) slave devices.

The serial communication interface module offers the following:

- UART features:
 - Full-duplex operation
 - Standard non return-to-zero (NRZ) mark/space format
 - Data buffers with 4-byte receive, 4-byte transmit
 - Configurable word length (8-bit or 9-bit words)
 - Error detection and flagging
 - Parity, noise and framing errors
 - Interrupt driven operation with 4 interrupts sources
 - Separate transmitter and receiver CPU interrupt sources
 - 16-bit programmable baud-rate modulus counter and 16-bit fractional
 - 2 receiver wake-up methods
- LIN features:
 - Autonomous LIN frame handling
 - Message buffer to store identifier and up to eight data bytes
 - Supports message length of up to 64 bytes
 - Detection and flagging of LIN errors
 - Sync field; Delimiter; ID parity; Bit, Framing; Checksum and Timeout errors
 - Classic or extended checksum calculation
 - Configurable Break duration of up to 36-bit times
 - Programmable Baud rate prescalers (13-bit mantissa, 4-bit fractional)
 - Diagnostic features
 - Loop back
 - Self Test
 - LIN bus stuck dominant detection
 - Interrupt driven operation with 16 interrupt sources
 - LIN slave mode features
 - Autonomous LIN header handling
 - Autonomous LIN response handling
 - Discarding of irrelevant LIN responses using up to 16 ID filters

1.2.15 Controller area network (CAN) module

The PXR40 contains four controller area network (CAN) blocks.

Each CAN module provides the following features:

- 64 message buffers (MB) of zero to eight bytes data length
- Based on and including all existing features of the Freescale TouCAN module
- Full implementation of the CAN protocol specification, Version 2.0B
 - Standard data and remote frames
 - Extended data and remote frames
 - Zero to eight bytes data length
 - Programmable bit rate as fast as 1 Mb/sec
 - Content-related addressing
- Each MB configurable as receive (Rx) or transmit (Tx), all supporting standard and extended messages
- Individual Rx mask registers per message buffer
- Includes 1056 bytes of RAM used for message buffer storage
- Includes 256 bytes of RAM used for individual Rx mask registers
- Full featured Rx FIFO with storage capacity for six frames and internal pointer handling
- Powerful Rx FIFO ID filtering, capable of matching incoming IDs against either eight extended, 16 standard, or 32 partial (8 bits) IDs, with individual masking capability
- Selectable backwards compatibility with previous CAN version
- Programmable clock source to the CAN protocol interface, either bus clock or crystal oscillator
- Unused message buffer and Rx mask register space can be used as general-purpose RAM space
- Listen-only mode capability
- Programmable loop-back mode supporting self-test operation
- Programmable transmission priority scheme: lowest ID, lowest buffer number or local priority on individual Tx message buffers.
- Hardware cancellation on Tx message buffers.
- Time stamp based on 16-bit free-running timer
- Global network time, synchronized by a specific message
- Maskable interrupts
- Independent of the transmission medium (an external transceiver is assumed)
- Short latency time due to an arbitration scheme for high-priority messages
- Low-power modes, with programmable wake-up on bus activity

1.2.16 Enhanced direct memory access controller (eDMA2)

The following summarizes the PXR40's implementation of the eDMA2 controller:

- Second-generation modules capable of performing complex data movements via 64 programmable channels (eDMA2-A) and 32 programmable channels (eDMA2-B), without intervention from the host processor
- DMA engine

- Performs source and destination address calculations
- Performs data movement operations
- Includes SRAM-based memory containing the transfer control descriptors (TCD) for the channels.
- All data movement via dual-address transfers: read from source, write to destination
- Programmable source and destination addresses, transfer size, plus support for enhanced addressing modes
- TCD organized to support two-deep, nested transfer operations
- An inner data transfer loop defined by a “minor” byte transfer count
- An outer data transfer loop defined by a “major” iteration count
- Channel activation via one of three methods:
 - Explicit software initiation
 - Initiation via a channel-to-channel linking mechanism for continuous transfers
 - Peripheral-paced hardware requests (one per channel)
- Support for fixed-priority and round-robin channel arbitration
- Channel completion reported via optional interrupt requests
- One interrupt per channel, optionally asserted at completion of major iteration count
- Error termination interrupts are optionally enabled
- Support for scatter/gather DMA processing
- Channel transfers can be suspended by a higher priority channel
- Nexus data trace support on each DMA

1.2.17 Crossbar switch (XBAR)

The following summarizes the PXR40’s implementation of the crossbar switch:

- Supports simultaneous connections between master ports and slave ports (each master must access a different slave)
- Supports a 32-bit address bus width and a 64-bit data bus width
- Six master ports:
 - e200z7 core complex (two ports)
 - eDMA2 module A
 - eDMA2 module B
 - FlexRay
 - Nexus debug interface (NDI)
- Four slave ports
 - Flash memory
 - SRAM
 - Peripheral bridge A
 - Peripheral bridge B

- Arbitration logic for when a slave port is simultaneously requested by more than one master
- Includes memory protection unit (MPU) hardware to guard against unintended SRAM or peripheral accesses by the CPU, eDMA2 modules, and FlexRay module.

1.2.18 Power management unit (PMU)

The PXR40's power management unit includes the following features:

- Internally the chip has four supply voltages, nominally 5 V, 3.3 V, 1.2 V and V_{STBY}
- Externally 5 V is required with the 3.3 V being supplied by an internal regulator running off the 5 V supply
 - Can also supply 3.3 V externally
- On-chip regulator controller supplies the 1.2 V via external components
- Option to externally supply V_{STBY} when the application requires standby RAM
- All supply voltages have voltage monitors and both the VDD regulator and all monitors except V_{STBY} are adjustable
- The chip uses a protected POR strategy, that is, the chip is guaranteed to run at the voltage point that RESET is released

1.2.19 Interrupt controller (INTC)

The PXR40 implements an interrupt controller that features the following:

- Priority-based preemptive scheduling of interrupt service requests (ISRs), suitable for statically scheduled hard real-time systems
- 448 software-configurable interrupt sources
 - Can be used to break the work involved in servicing an interrupt request into a high priority portion and a low priority portion:
High priority portion is initiated by a peripheral interrupt request, but then the ISR asserts a software-configurable interrupt request to finish the servicing in a lower priority ISR.
Therefore these software-configurable interrupt requests can be used instead of the peripheral ISR scheduling a task through the RTOS.
- 16 priority levels so that lower priority ISRs do not delay the execution of higher priority ISRs
- Software-configurable priorities of ISR or tasks
 - Modifying the priority can be used to implement the priority ceiling protocol for accessing shared resources
- For high priority interrupt requests, minimized time from the assertion of the interrupt request from the peripheral to when the processor is executing the interrupt service routine (ISR)
- A unique vector for each interrupt request source for quick determination of which ISR needs to be executed
- Support for a critical or non maskable interrupt
 - Non-maskable interrupt (NMI) multiplexed on WKPCFG pin to allow connection to the critical or non maskable input of the CPU core, bypassing the interrupt controller and all

multiplexing and selection logic (provides an interrupt request to the core that is higher priority than any other interrupting source in the device)

1.2.20 Frequency-modulated PLL (FMPLL)

The FMPLL allows the user to generate high speed system clocks using a 4 MHz to 40 MHz crystal oscillator or external clock generator. Further, the FMPLL supports programmable frequency modulation of the system clock to reduce electromagnetic emissions peaks. The PLL multiplication factor and output clock divider ratio are all software configurable. The PLL has the following major features:

- Input clock frequency selectable in two ranges:
 - From 4 MHz to 20 MHz
 - From 8 MHz to 40 MHz (when PLLCFG2 pulled high)
- Voltage controlled oscillator (VCO) range from 192 MHz to 680 MHz
- Reduced frequency divider (RFD) for reduced frequency operation without requiring PLL relock
- Three modes of operation:
 - Bypass mode with PLL off
 - Bypass mode with PLL running (default mode out of reset)
 - PLL normal mode
- Each of the three modes may be run with a crystal oscillator or an external clock reference
- Programmable frequency modulation ¹
 - Modulation enabled/disabled through software
 - Triangle wave modulation
 - Programmable modulation depth
 - Programmable modulation frequency dependent on reference frequency
- Lock detect circuitry reports when the PLL has achieved frequency lock and continuously monitors lock status to report loss of lock conditions
- Clock quality module
 - Optionally causes an interrupt request or system reset if the crystal clock frequency falls outside a predefined range
 - Optionally causes a system reset, or switches the system clock to the crystal clock and causes an interrupt request, if the PLL output clock frequency falls outside a predefined range
- Programmable interrupt request or system reset on loss of lock
- Self-clocked mode (SCM) operation allows continued operation after failure of crystal clock
- Configuration registers defined as an upwardly compatible superset of MPC5500 FMPLL registers

1. You must configure the FMPLL to ensure that the maximum specified system frequency is not exceeded when frequency modulation is enabled.

1.2.21 System Integration Unit (SIU)

The SIU provides the following features:

- System configuration
 - MCU reset configuration via external pins
 - Pad configuration control for each pad
 - Control of virtual I/O via SPI serialization
- System reset monitoring and generation
 - Power-on reset support
 - Reset status register provides last reset source to software
 - Glitch detection on reset input
 - Software controlled reset assertion
- External interrupt
 - Sixteen interrupt requests
 - Rising or falling edge event detection
 - Programmable digital filter for glitch rejection
 - Critical interrupt request
 - Non maskable interrupt request
- GPIO
 - Virtual GPIO via SPI serialization (requires external deserialization device)
 - Dedicated input and output registers for setting each GPIO and virtual-GPIO pin
 - Parallel GPIO enables access to as many as eight GPIOs in one write
- Internal multiplexing
 - Allows serial and parallel chaining of SPIs
 - Allows flexible selection of eQADC trigger inputs
 - Allows selection of interrupt requests between external pins and SPI

1.2.22 Boot assist module (BAM)

The BAM is a block of read-only memory containing code that is executed every time the MCU is powered-on or reset in normal mode. The BAM supports multiple boot modes:

- Booting from internal flash memory
- Serial boot loading (a program is downloaded into on-chip general-purpose SRAM via UART or the CAN and then executed)

The BAM also reads the reset configuration half word (RCHW) from flash memory (which may be external to the device) and configures the PXR40 hardware accordingly. The BAM provides the following features:

- Sets up MMU to cover all resources and mapping all physical addresses to logical addresses with minimum address translation

- Sets up the MMU to allow application boot code to execute as either Classic Power Architecture Book E code (default) or as Freescale VLE code
- Location and detection of application boot code
- Automatic switch to serial boot mode if internal flash memory is blank or invalid
- Supports software-programmable 64-bit password protection for serial boot mode
- Autobaud function in SCI and CAN download mode¹
- Supports censorship protection for internal flash memory
- Provides an option to enable the software watchdog timer

1.2.23 Dual-channel FlexRay controller

The PXR40 contains one dual-channel FlexRay controller. The controller fully implements the FlexRay Protocol Specification Version 2.1 Rev A. The FlexRay protocol is designed to facilitate implementation of fault tolerant, time-triggered, and highly dependable control systems by offering a fault tolerant clock synchronization mechanism. The FlexRay protocol maintains the global time across the functional nodes of a network with a precision (jitter) of maximum 1 μ s at a data rate of 10 Mbit/sec and redundant communication channels.

The FlexRay controller provides the following features:

- FlexRay Communications System Protocol Specification, Version 2.1 Rev A compliant protocol implementation
- FlexRay Communications System Electrical Physical Layer Specification, Version 2.1 Rev A compliant bus driver interface
- Single channel support
 - FlexRay Port A can be configured to be connected either to physical FlexRay channel A or physical FlexRay channel B.
- FlexRay bus data rates of 10 Mbit/sec, 8 Mbit/sec, 5 Mbit/sec, and 2.5 Mbit/sec supported
- 128 configurable message buffers with
 - Individual frame ID filtering
 - Individual channel ID filtering
 - Individual cycle counter filtering
- Message buffer header, status and payload data stored in dedicated FlexRay memory
 - Allows for flexible and efficient message buffer implementation
 - Consistent data access ensured by means of buffer locking scheme
 - Application can lock multiple buffers at the same time
- Size of message buffer payload data section configurable from 0 to 254 bytes
- Two independent message buffer segments with configurable size of payload data section
 - Each segment can contain message buffers assigned to the static segment and message buffers assigned to the dynamic segment at the same time

¹. Feature available only on revision 2 release of device.

- Zero padding for transmit message buffers in static segment
 - Applied when the frame payload length exceeds the size of the message buffer data section
- Transmit message buffers configurable with state/event semantics
- Message buffers can be configured as
 - Receive message buffer
 - Single-buffered transmit message buffer
 - Double-buffered transmit message buffer (combines two single buffered message buffer)
- Individual message buffer reconfiguration supported
 - Means provided to safely disable individual message buffers
 - Disabled message buffers can be reconfigured
- Two independent receive FIFOs
 - One receive FIFO per channel
 - As many as 255 entries for each FIFO
 - Global frame ID filtering, based on both value/mask filters and range filters
 - Global channel ID filtering
 - Global message ID filtering for the dynamic segment
- Four configurable slot error counters
- Four dedicated slot status indicators
 - Used to observe slots without using receive message buffers
- Measured value indicators for the clock synchronization
 - Internal synchronization frame ID and synchronization frame measurement tables can be copied into the FlexRay memory
- Fractional macroticks are supported for clock correction
- Maskable interrupt sources provided via individual and combined interrupt lines
- One absolute timer
- One timer that can be configured as absolute or relative
- Nexus data trace support

1.2.24 JTAG controller (JTAGC)

The JTAG controller (JTAGC) block provides the means to test chip functionality and connectivity while remaining transparent to system logic when not in test mode. Testing is performed via a boundary scan technique, as defined in the IEEE 1149.1-2001 standard. All data input to and output from the JTAGC block is communicated in serial format. The JTAGC block is compliant with the IEEE 1149.1-2001 and IEEE 1149.7 standards, and supports the following features:

- IEEE 1149.1-2001 Test Access Port (TAP) interface five pins (JCOMP, TDI, TMS, TCK, and TDO)
- IEEE 1149.7 Serial JTAG Test Access Port interface three pins (JCOMP, TMS, TCK)
- A 5-bit instruction register that supports the following IEEE 1149.1-2001 defined instructions:

- BYPASS, IDCODE, EXTEST, SAMPLE, SAMPLE/PRELOAD, HIGHZ, CLAMP
- A 5-bit instruction register that supports the additional following public instructions:
 - ACCESS_AUX_TAP_NPC, ACCESS_AUX_TAP_ONCE, ACCESS_AUX_TAP_eTPU, ACCESS_AUX_TAP_DMAAN3, ACCESS_AUX_TAP_DMABN3, ACCESS_AUX_TAP_FLEXRAY
- Three test data registers: a bypass register, a boundary scan register, and a device identification register. The size of the boundary scan register is parameterized to support a variety of boundary scan chain lengths.
- A TAP controller state machine that controls the operation of the data registers, instruction register and associated circuitry.
- Censorship inhibit register
 - 64-bit censorship password register
 - If the external tool writes a 64-bit password that matches the serial boot password stored in the internal flash memory shadow row, censorship is disabled until the next JTAG reset

1.2.25 Nexus

The Nexus debug interface (NDI) block provides real-time development support capabilities for the PXR40 in compliance with the IEEE-ISTO 5001-2003 standard. This development support is supplied for MCUs without requiring external address and data pins for internal visibility. The NDI block is an integration of several individual Nexus blocks that are selected to provide the development support interface for the PXR40. The NDI block interfaces to the host processor, the eTPU, and internal buses to provide development support as per the IEEE-ISTO 5001-2003 standard. The development support provided includes program trace, data trace, watchpoint trace, ownership trace, run-time access to the MCU's internal memory map and access to the Power Architecture and eTPU internal registers during halt. The Nexus interface also supports a JTAG-only mode using only the JTAG pins. Nexus also provides data trace support for flexray and both eDMA2s. The following features are implemented:

- 23 or 27 full duplex pin interface for medium and high visibility throughput
 - One of two modes selected by register configuration:
 - Reduced-port mode (RPM) comprises 12 MDO (message data out) pins
 - Full-port mode (FPM) comprises 16 MDO pins
 - Auxiliary output port
- Debug support pins
 - One MCKO (message clock out) pin
 - 12 or 16 MDO (message data out) pins
 - Two $\overline{\text{MSE0}}$ (message start/end out) pins
 - One $\overline{\text{RDY}}$ (ready) pin
 - One $\overline{\text{EVTO}}$ (event out) pin
 - Auxiliary input port
 - One $\overline{\text{EVTI}}$ (event in) pin
 - 5-pin JTAG port (JCOMP, TDI, TDO, TMS, and TCK) or 3-pin (JCOMP, TMS, and TCK)

- Reduced-pin JTAG mode as per IEEE 1149.7
- Host processor (e200z7) standard class 3 compliant
- eTPU development support standard class 3 compliant
- Supports data trace for the FlexRay controller and both eDMA2 modules
- Run-time access to the on-chip memory map via the Nexus read/write access protocol
- All features are independently configurable and controllable via the IEEE 1149.1 I/O port
- The NDI block reset is controlled with JCOMP, power-on reset, and the TAP state machine. All these sources are independent of system reset.
- Power-on-reset status indication during reset via MDO[0] in disabled and reset modes

1.3 Developer Environment

The PXR40 supports several tools to enable easier application development.

The following development support will be available.

- Tower system modules for evaluation and prototyping
- Compilers
- Debuggers
- JTAG and Nexus interfaces
- RAppID™ Initialization tool

Chapter 2 Memory Map

2.1 Introduction

All addresses in the device, including those that are reserved, are identified in the following tables. The addresses represent the physical addresses assigned to each block. Logical addresses are translated by the MMU into physical addresses.

Under software control of the Memory Management Unit (MMU), the logical addresses allocated to IP blocks may be changed on a minimum of a 4 KB boundary. [Table 2-1](#) shows this device's memory map.

Table 2-1. PXR40 memory map

| Block | Address |
|-------------------------------|-------------------------|
| Flash (4 MB) | 0x0000_0000—0x003F_FFFF |
| Reserved | 0x0040_0000—0x00EF_BFFF |
| Flash B Shadow Block | 0x00EF_C000—0x00EF_FFFF |
| Reserved | 0x00F0_0000—0x00FF_BFFF |
| Flash A Shadow Block | 0x00FF_C000—0x00FF_FFFF |
| Emulation re-mapping of flash | 0x0100_0000—0x1FFF_FFFF |
| External Development Memory | 0x2000_0000—0x3FFF_FFFF |
| Internal Standby SRAM (32 KB) | 0x4000_0000—0x4000_7FFF |
| Internal SRAM (224 KB) | 0x4000_8000—0x4003_FFFF |
| Reserved | 0x4004_0000—0xC3EF_FFFF |
| Peripheral Bridge A Registers | 0xC3F0_0000—0xC3F0_3FFF |
| Reserved | 0xC3F0_4000—0xC3F7_FFFF |
| FMPLL | 0xC3F8_0000—0xC3F8_3FFF |
| EBI Configuration | 0xC3F8_4000—0xC3F8_7FFF |
| Flash A Configuration | 0xC3F8_8000—0xC3F8_BFFF |
| Flash B Configuration | 0xC3F8_C000—0xC3F8_FFFF |
| SIU | 0xC3F9_0000—0xC3F9_3FFF |
| Reserved | 0xC3F9_4000—0xC3F9_FFFF |
| eMIOS | 0xC3FA_0000—0xC3FA_3FFF |
| Reserved | 0xC3FA_4000—0xC3FB_BFFF |

Table 2-1. PXR40 memory map (continued)

| Block | Address |
|---------------------------|-------------------------|
| PMC | 0xC3FB_C000—0xC3FB_FFFF |
| eTPU Registers | 0xC3FC_0000—0xC3FC_3FFF |
| Reserved | 0xC3FC_4000—0xC3FC_7FFF |
| eTPU Parameter RAM | 0xC3FC_8000—0xC3FC_97FF |
| eTPU Parameter RAM Mirror | 0xC3FC_C000—0xC3FC_D7FF |
| eTPU Code RAM | 0xC3FD_0000—0xC3FD_5FFF |
| Reserved | 0xC3FD_6000—0xC3FE_FFFF |
| PIT / RTI | 0xC3FF_0000—0xC3FF_3FFF |
| Reserved | 0xC3FF_4000—0xC3FF_BFFF |
| Reserved | 0xC3FF_C000—0xC3FF_FFFF |

| | |
|-------------------------------|---------------------------|
| Peripheral Bridge B registers | 0xFFFF0_0000—0xFFFF0_3FFF |
| XBAR (AXBS) | 0xFFFF0_4000—0xFFFF0_7FFF |
| Reserved | 0xFFFF0_8000—0xFFFF0_FFFF |
| MPU | 0xFFFF1_0000—0xFFFF1_3FFF |
| Reserved | 0xFFFF1_4000—0xFFFF3_7FFF |
| SWT | 0xFFFF3_8000—0xFFFF3_BFFF |
| STM | 0xFFFF3_C000—0xFFFF3_FFFF |
| ECSM | 0xFFFF4_0000—0xFFFF4_3FFF |
| eDMA_A | 0xFFFF4_4000—0xFFFF4_7FFF |
| INTC | 0xFFFF4_8000—0xFFFF4_BFFF |
| Reserved | 0xFFFF4_C000—0xFFFF5_3FFF |
| eDMA_B | 0xFFFF5_4000—0xFFFF5_7FFF |
| Reserved | 0xFFFF5_8000—0xFFFF7_FFFF |
| eQADC_A | 0xFFFF8_0000—0xFFFF8_3FFF |
| eQADC_B | 0xFFFF8_4000—0xFFFF8_7FFF |
| Decimation filter A | 0xFFFF8_8000—0xFFFF8_87FF |
| Decimation filter B | 0xFFFF8_8800—0xFFFF8_8FFF |
| Decimation filter C | 0xFFFF8_9000—0xFFFF8_97FF |
| Decimation filter D | 0xFFFF8_9800—0xFFFF8_9FFF |
| Decimation filter E | 0xFFFF8_A000—0xFFFF8_A7FF |
| Decimation filter F | 0xFFFF8_A800—0xFFFF8_AFFF |
| Decimation filter G | 0xFFFF8_B000—0xFFFF8_B7FF |

Table 2-1. PXR40 memory map (continued)

| Block | Address |
|---|----------------------------|
| Decimation filter H | 0xFFFF8_B800—0xFFFF8_BFFF |
| Reserved | 0xFFFF8_C000—0xFFFF8_FFFF |
| DSPI_A | 0xFFFF9_0000— 0xFFFF9_3FFF |
| DSPI_B | 0xFFFF9_4000—0xFFFF9_7FFF |
| DSPI_C | 0xFFFF9_8000— 0xFFFF9_BFFF |
| DSPI_D | 0xFFFF9_C000— 0xFFFF9_FFFF |
| Reserved | 0xFFFFA_0000—0xFFFFA_FFFF |
| eSCI_A | 0xFFFFB_0000—0xFFFFB_3FFF |
| eSCI_B | 0xFFFFB_4000—0xFFFFB_7FFF |
| eSCI_C | 0xFFFFB_8000—0xFFFFB_BFFF |
| Reserved | 0xFFFFB_C0000—0xFFFFB_FFFF |
| FlexCAN_A | 0xFFFFC_0000—0xFFFFC_3FFF |
| FlexCAN_B | 0xFFFFC_4000—0xFFFFC_7FFF |
| FlexCAN_C | 0xFFFFC_8000—0xFFFFC_BFFF |
| FlexCAN_D | 0xFFFFC_C000—0xFFFFC_FFFF |
| Reserved | 0xFFFFD_0000—0xFFFFD_FFFF |
| FlexRay | 0xFFFFE_0000—0xFFFFE_3FFF |
| Reserved | 0xFFFFE_4000—0xFFFFE_BFFF |
| System Information Module (temp. sensor and unique device ID) | 0xFFFFE_C000—0xFFFFE_FFFF |
| Reserved | 0xFFFFF_0000—0xFFFFF_BFFF |
| Boot Assist Module (BAM) | 0xFFFFF_C000—0xFFFFF_FFFF |

Chapter 3

Signal Descriptions

This chapter describes the external device signals, including a table of signal properties, detailed descriptions of the available signals, and the I/O pin power/ground segmentation.

3.1 Pin Function Selection

3.1.1 Pad Configuration Register (PCR) PA Definition

Most pins (balls) on the package support more than one function. Unlike prior devices in this class, the required pin function on this device is selected by a fixed size of the PA bit field in each SIU_PCR. The PA width is fixed at 3 bits. The pin function categories are:

Table 3-1. SIU_PCR PA Definition

| PA | Function Category |
|-----|---------------------------|
| 000 | GPIO |
| 001 | Primary Function |
| 010 | Alternate function 1 (A1) |
| 011 | Alternate function 2 (A2) |
| 100 | Alternate function 3 (A3) |

Pins that do not require selection of a function by modifying the PA field have a hard-wired value corresponding to the appropriate function available at the pin. All PA values might not be used. A definition of which values are used is provided in the SIU chapter's PCR settings table. The "Primary Function" name is retained from previous MPC5xxx designs and indicates the name used on the ball map. The name "GPIO" is also retained for clarity. The remaining function names are new and have been chosen for simplicity and clarity.

3.1.2 LVDS Signal Selection

A pin (ball) that is driven by a signal from a 5V pad or from an LVDS pad has a single PCR controlling both signals. Different values of PA select either the 5V signal or the LVDS signal. Note that a single LVDS pad supplies two signals — a "true" and a "complement" output. This means that one LVDS pad drives two balls, but each ball has a separate PCR (and PA field). The two LVDS signals are enabled only when the PA values in both PCRs are set to select LVDS operation. Both LVDS signals are deselected when either PA is set to a value that deselects its LVDS signal. The ball that has its PA field still set to LVDS will go to an undriven state until its PA field is updated to a non-LVDS value.

Table 3-2 is an example of the options for PA on two balls, where “true” and “complement” LVDS outputs are multiplexed with SCK_C and SINC.

Table 3-2. LVDS example

| PCR235 ¹ [PA] Selection | PCR236 ² [PA] Selection | SCKC Ball function | SINC Ball function |
|------------------------------------|------------------------------------|--------------------|--------------------|
| SCKC | SINC | SCKC | SINC |
| LVDS | LVDS | SCK_C_LVDS+ | SCK_C_LVDS- |
| SCKC | LVDS | SCKC | undriven |
| LVDS | SINC | undriven | SINC |

¹ SCKC_SCK_C_LVDS_P_GPIO235

² SINC_SCK_C_LVDS_P_GPIO236

Additionally, when LVDS signals are enabled on balls, their PCR SRC[1:0] bits control the differential signal output swing increase and decrease, as defined in Table 3-3.

Table 3-3. Differential Signal Output when LVDS is Enabled

| SRC1 | SRC0 | Current flowing in the driver | Differential Voltage Across ‘true’ and ‘complement’ |
|------|------|-------------------------------|---|
| 0 | 0 | normal | default |
| 0 | 1 | increased | increased (20%) |
| 1 | 0 | decreased | decreased (20%) |
| 1 | 1 | normal | same as default |

3.2 External Signal Descriptions, Pin Multiplexing, and Attributes

This section summarizes the external signal functions, their static electrical characteristics, and pad configuration settings for this device. The signal properties and their electrical characteristics are set in the System Integration Unit (SIU) Pad Configuration (PCR) registers. See the *PXR40 Microcontroller Data Sheet* for ball-map figures.

Table 3-4. Signal Properties and Muxing Summary

| GPIO/PCR ¹ | Signal Name ² | P/A/G ³ | Function ⁴ | Function Summary | Direction | Pad Type ⁵ | Voltage ⁶ | State during RESET ⁷ | State after RESET ⁸ | Package Location (416) |
|-----------------------|----------------------------|--------------------|-----------------------|------------------------------|-----------|-----------------------|----------------------|---------------------------------|--------------------------------|------------------------|
| eTPU_A | | | | | | | | | | |
| 113 | TCRCLKA_IRQ7_ GPIO113 | P | TCRCLKA | eTPU A TCR clock | I | MH | V _{DDEH1} | —/Up | —/Up | L1 |
| | | A1 | IRQ7 | External interrupt request | I | | | | | |
| | | A2 | — | — | — | | | | | |
| | | G | GPIO113 | GPIO | I/O | | | | | |
| 114 | ETPUA0_ETPUA12_ GPIO114 | P | ETPUA0 | eTPU A channel | I/O | MH | V _{DDEH1} | —/WKPCFG | —/WKPCFG | L2 |
| | | A1 | ETPUA12 | eTPU A channel (output only) | O | | | | | |
| | | A2 | — | — | — | | | | | |
| | | G | GPIO114 | GPIO | I/O | | | | | |
| 115 | ETPUA1_ETPUA13_ GPIO115 | P | ETPUA1 | eTPU A channel | I/O | MH | V _{DDEH1} | —/WKPCFG | —/WKPCFG | L3 |
| | | A1 | ETPUA13 | eTPU A channel (output only) | O | | | | | |
| | | A2 | — | — | — | | | | | |
| | | G | GPIO115 | GPIO | I/O | | | | | |
| 116 | ETPUA2_ETPUA14_ GPIO116 | P | ETPUA2 | eTPU A channel | I/O | MH | V _{DDEH1} | —/WKPCFG | —/WKPCFG | L4 |
| | | A1 | ETPUA14 | eTPU A channel (output only) | O | | | | | |
| | | A2 | — | — | — | | | | | |
| | | G | GPIO116 | GPIO | I/O | | | | | |

Table 3-4. Signal Properties and Muxing Summary (continued)

| GPIO/PCR ¹ | Signal Name ² | P/A/G ³ | Function ⁴ | Function Summary | Direction | Pad Type ⁵ | Voltage ⁶ | State during RESET ⁷ | State after RESET ⁸ | Package Location (416) |
|-----------------------|----------------------------|--------------------|-----------------------|------------------------------|-----------|-----------------------|----------------------|---------------------------------|--------------------------------|------------------------|
| 117 | ETPUA3_ETPUA15_ GPIO117 | P | ETPUA3 | eTPU A channel | I/O | MH | V _{DDEH1} | —/WKPCFG | —/WKPCFG | K1 |
| | | A1 | ETPUA15 | eTPU A channel (output only) | O | | | | | |
| | | A2 | — | — | — | | | | | |
| | | G | GPIO117 | GPIO | I/O | | | | | |
| 118 | ETPUA4_ETPUA16_ GPIO118 | P | ETPUA4 | eTPU A channel | I/O | MH | V _{DDEH1} | —/WKPCFG | —/WKPCFG | K2 |
| | | A1 | ETPUA16 | eTPU A channel (output only) | O | | | | | |
| | | A2 | — | — | — | | | | | |
| | | G | GPIO118 | GPIO | I/O | | | | | |
| 119 | ETPUA5_ETPUA17_ GPIO119 | P | ETPUA5 | eTPU A channel | I/O | MH | V _{DDEH1} | —/WKPCFG | —/WKPCFG | K3 |
| | | A1 | ETPUA17 | eTPU A channel (output only) | O | | | | | |
| | | A2 | — | — | — | | | | | |
| | | G | GPIO119 | GPIO | I/O | | | | | |
| 120 | ETPUA6_ETPUA18_ GPIO120 | P | ETPUA6 | eTPU A channel | I/O | MH | V _{DDEH1} | —/WKPCFG | —/WKPCFG | K4 |
| | | A1 | ETPUA18 | eTPU A channel (output only) | O | | | | | |
| | | A2 | — | — | — | | | | | |
| | | G | GPIO120 | GPIO | I/O | | | | | |
| 121 | ETPUA7_ETPUA19_ GPIO121 | P | ETPUA7 | eTPU A channel | I/O | MH | V _{DDEH1} | —/WKPCFG | —/WKPCFG | J1 |
| | | A1 | ETPUA19 | eTPU A channel (output only) | O | | | | | |
| | | A2 | — | — | — | | | | | |
| | | G | GPIO121 | GPIO | I/O | | | | | |
| 122 | ETPUA8_ETPUA20_ GPIO122 | P | ETPUA8 | eTPU A channel | I/O | MH | V _{DDEH1} | —/WKPCFG | —/WKPCFG | J2 |
| | | A1 | ETPUA20 | eTPU A channel (output only) | O | | | | | |
| | | A2 | — | — | — | | | | | |
| | | G | GPIO122 | GPIO | I/O | | | | | |

Table 3-4. Signal Properties and Muxing Summary (continued)

| GPIO/PCR ¹ | Signal Name ² | P/A/G ³ | Function ⁴ | Function Summary | Direction | Pad Type ⁵ | Voltage ⁶ | State during RESET ⁷ | State after RESET ⁸ | Package Location (416) |
|-----------------------|-----------------------------|--------------------|-----------------------|-------------------------------|-----------|-----------------------|----------------------|---------------------------------|--------------------------------|------------------------|
| 123 | ETPUA9_ETPUA21_ GPIO123 | P | ETPUA9 | eTPU A channel | I/O | MH | V _{DDEH1} | —/WKPCFG | —/WKPCFG | J3 |
| | | A1 | ETPUA21 | eTPU A channel (output only) | O | | | | | |
| | | A2 | — | — | — | | | | | |
| | | G | GPIO123 | GPIO | I/O | | | | | |
| 124 | ETPUA10_ETPUA22_ GPIO124 | P | ETPUA10 | eTPU A channel | I/O | MH | V _{DDEH1} | —/WKPCFG | —/WKPCFG | J4 |
| | | A1 | ETPUA22 | eTPU A channel (output only) | O | | | | | |
| | | A2 | — | — | — | | | | | |
| | | G | GPIO124 | GPIO | I/O | | | | | |
| 125 | ETPUA11_ETPUA23_ GPIO125 | P | ETPUA11 | eTPU A channel | I/O | MH | V _{DDEH1} | —/WKPCFG | —/WKPCFG | H1 |
| | | A1 | ETPUA23 | eTPU A channel (output only) | O | | | | | |
| | | A2 | — | — | — | | | | | |
| | | G | GPIO125 | GPIO | I/O | | | | | |
| 126 | ETPUA12_PCSB1_ GPIO126 | P | ETPUA12 | eTPU A channel | I/O | MH | V _{DDEH1} | —/WKPCFG | —/WKPCFG | H2 |
| | | A1 | PCSB1 | DSPI B peripheral chip select | O | | | | | |
| | | A2 | — | — | — | | | | | |
| | | G | GPIO126 | GPIO | I/O | | | | | |
| 127 | ETPUA13_PCSB3_ GPIO127 | P | ETPUA13 | eTPU A channel | I/O | MH | V _{DDEH1} | —/WKPCFG | —/WKPCFG | H4 |
| | | A1 | PCSB3 | DSPI B peripheral chip select | O | | | | | |
| | | A2 | — | — | — | | | | | |
| | | G | GPIO127 | GPIO | I/O | | | | | |
| 128 | ETPUA14_PCSB4_ GPIO128 | P | ETPUA14 | eTPU A channel | I/O | MH | V _{DDEH1} | —/WKPCFG | —/WKPCFG | H3 |
| | | A1 | PCSB4 | DSPI B peripheral chip select | O | | | | | |
| | | A2 | — | — | — | | | | | |
| | | G | GPIO128 | GPIO | I/O | | | | | |

Table 3-4. Signal Properties and Muxing Summary (continued)

| GPIO/PCR ¹ | Signal Name ² | P/A/G ³ | Function ⁴ | Function Summary | Direction | Pad Type ⁵ | Voltage ⁶ | State during RESET ⁷ | State after RESET ⁸ | Package Location (416) |
|-----------------------|---------------------------|--------------------|-----------------------|-------------------------------|-----------|-----------------------|----------------------|---------------------------------|--------------------------------|------------------------|
| 129 | ETPUA15_PCSB5_ GPIO129 | P | ETPUA15 | eTPU A channel | I/O | MH | V _{DDEH1} | —/WKPCFG | —/WKPCFG | G1 |
| | | A1 | PCSB5 | DSPI B peripheral chip select | O | | | | | |
| | | A2 | — | — | — | | | | | |
| | | G | GPIO129 | GPIO | I/O | | | | | |
| 130 | ETPUA16_PCSD1_ GPIO130 | P | ETPUA16 | eTPU A channel | I/O | MH | V _{DDEH1} | —/WKPCFG | —/WKPCFG | G2 |
| | | A1 | PCSD1 | DSPI D peripheral chip select | O | | | | | |
| | | A2 | — | — | — | | | | | |
| | | G | GPIO130 | GPIO | I/O | | | | | |
| 131 | ETPUA17_PCSD2_ GPIO131 | P | ETPUA17 | eTPU A channel | I/O | MH | V _{DDEH1} | —/WKPCFG | —/WKPCFG | G3 |
| | | A1 | PCSD2 | DSPI D peripheral chip select | O | | | | | |
| | | A2 | — | — | — | | | | | |
| | | G | GPIO131 | GPIO | I/O | | | | | |
| 132 | ETPUA18_PCSD3_ GPIO132 | P | ETPUA18 | eTPU A channel | I/O | MH | V _{DDEH1} | —/WKPCFG | —/WKPCFG | G4 |
| | | A1 | PCSD3 | DSPI D peripheral chip select | O | | | | | |
| | | A2 | — | — | — | | | | | |
| | | G | GPIO132 | GPIO | I/O | | | | | |
| 133 | ETPUA19_PCSD4_ GPIO133 | P | ETPUA19 | eTPU A channel | I/O | MH | V _{DDEH1} | —/WKPCFG | —/WKPCFG | F1 |
| | | A1 | PCSD4 | DSPI D peripheral chip select | O | | | | | |
| | | A2 | — | — | — | | | | | |
| | | G | GPIO133 | GPIO | I/O | | | | | |
| 134 | ETPUA20_IRQ8_ GPIO134 | P | ETPUA20 | eTPU A channel | I/O | MH | V _{DDEH1} | —/WKPCFG | —/WKPCFG | F2 |
| | | A1 | IRQ8 | External interrupt request | I | | | | | |
| | | A2 | — | — | — | | | | | |
| | | G | GPIO134 | GPIO | I/O | | | | | |

Table 3-4. Signal Properties and Muxing Summary (continued)

| GPIO/PCR ¹ | Signal Name ² | P/A/G ³ | Function ⁴ | Function Summary | Direction | Pad Type ⁵ | Voltage ⁶ | State during RESET ⁷ | State after RESET ⁸ | Package Location (416) |
|-----------------------|---------------------------|--------------------|-----------------------|----------------------------|-----------|-----------------------|----------------------|---------------------------------|--------------------------------|------------------------|
| 135 | ETPUA21_IRQ9_ GPIO135 | P | ETPUA21 | eTPU A channel | I/O | MH | V _{DDEH1} | —/WKPCFG | —/WKPCFG | F3 |
| | | A1 | IRQ9 | External interrupt request | I | | | | | |
| | | A2 | — | — | — | | | | | |
| | | G | GPIO135 | GPIO | I/O | | | | | |
| 136 | ETPUA22_IRQ10_ GPIO136 | P | ETPUA22 | eTPU A channel | I/O | MH | V _{DDEH1} | —/WKPCFG | —/WKPCFG | F4 |
| | | A1 | IRQ10 | External interrupt request | I | | | | | |
| | | A2 | — | — | — | | | | | |
| | | G | GPIO136 | GPIO | I/O | | | | | |
| 137 | ETPUA23_IRQ11_ GPIO137 | P | ETPUA23 | eTPU A channel | I/O | MH | V _{DDEH1} | —/WKPCFG | —/WKPCFG | E1 |
| | | A1 | IRQ11 | External interrupt request | I | | | | | |
| | | A2 | — | — | — | | | | | |
| | | G | GPIO137 | GPIO | I/O | | | | | |
| 138 | ETPUA24_IRQ12_ GPIO138 | P | ETPUA24 | eTPU A channel | I/O | MH | V _{DDEH1} | —/WKPCFG | —/WKPCFG | E2 |
| | | A1 | IRQ12 | External interrupt request | I | | | | | |
| | | A2 | — | — | — | | | | | |
| | | G | GPIO138 | GPIO | I/O | | | | | |
| 139 | ETPUA25_IRQ13_ GPIO139 | P | ETPUA25 | eTPU A channel | I/O | MH | V _{DDEH1} | —/WKPCFG | —/WKPCFG | E3 |
| | | A1 | IRQ13 | External interrupt request | I | | | | | |
| | | A2 | — | — | — | | | | | |
| | | G | GPIO139 | GPIO | I/O | | | | | |
| 140 | ETPUA26_IRQ14_ GPIO140 | P | ETPUA26 | eTPU A channel | I/O | MH | V _{DDEH1} | —/WKPCFG | —/WKPCFG | E4 |
| | | A1 | IRQ14 | External interrupt request | I | | | | | |
| | | A2 | — | — | — | | | | | |
| | | G | GPIO140 | GPIO | I/O | | | | | |

Table 3-4. Signal Properties and Muxing Summary (continued)

| GPIO/PCR ¹ | Signal Name ² | P/A/G ³ | Function ⁴ | Function Summary | Direction | Pad Type ⁵ | Voltage ⁶ | State during RESET ⁷ | State after RESET ⁸ | Package Location (416) |
|-----------------------|---------------------------|--------------------|-----------------------|-------------------------------|-----------|-----------------------|----------------------|---------------------------------|--------------------------------|------------------------|
| 141 | ETPUA27_IRQ15_ GPIO141 | P | ETPUA27 | eTPU A channel | I/O | MH | V _{DDEH1} | —/WKPCFG | —/WKPCFG | D1 |
| | | A1 | IRQ15 | External interrupt request | I | | | | | |
| | | A2 | — | — | — | | | | | |
| | | G | GPIO141 | GPIO | I/O | | | | | |
| 142 | ETPUA28_PCSC1_ GPIO142 | P | ETPUA28 | eTPU A channel | I/O | MH | V _{DDEH1} | —/WKPCFG | —/WKPCFG | D2 |
| | | A1 | PCSC1 | DSPI C peripheral chip select | O | | | | | |
| | | A2 | — | — | — | | | | | |
| | | G | GPIO142 | GPIO | I/O | | | | | |
| 143 | ETPUA29_PCSC2_ GPIO143 | P | ETPUA29 | eTPU A channel | I/O | MH | V _{DDEH1} | —/WKPCFG | —/WKPCFG | D3 |
| | | A1 | PCSC2 | DSPI C peripheral chip select | O | | | | | |
| | | A2 | — | — | — | | | | | |
| | | G | GPIO143 | GPIO | I/O | | | | | |
| 144 | ETPUA30_PCSC3_ GPIO144 | P | ETPUA30 | eTPU A channel | I/O | MH | V _{DDEH1} | —/WKPCFG | —/WKPCFG | C1 |
| | | A1 | PCSC3 | DSPI C peripheral chip select | O | | | | | |
| | | A2 | — | — | — | | | | | |
| | | G | GPIO144 | GPIO | I/O | | | | | |
| 145 | ETPUA31_PCSC4_ GPIO145 | P | ETPUA31 | eTPU A channel | I/O | MH | V _{DDEH1} | —/WKPCFG | —/WKPCFG | C2 |
| | | A1 | PCSC4 | DSPI C peripheral chip select | O | | | | | |
| | | A2 | — | — | — | | | | | |
| | | G | GPIO145 | GPIO | I/O | | | | | |
| eTPU_B | | | | | | | | | | |
| 146 | TCRCLKB_IRQ6_ GPIO146 | P | TCRCLKB | eTPU B TCR clock | I | MH | V _{DDEH6} | —/Up | —/Up | T23 |
| | | A1 | IRQ6 | External interrupt request | I | | | | | |
| | | A2 | — | — | — | | | | | |
| | | G | GPIO146 | GPIO | I/O | | | | | |

Table 3-4. Signal Properties and Muxing Summary (continued)

| GPIO/PCR ¹ | Signal Name ² | P/A/G ³ | Function ⁴ | Function Summary | Direction | Pad Type ⁵ | Voltage ⁶ | State during RESET ⁷ | State after RESET ⁸ | Package Location (416) |
|-----------------------|----------------------------|--------------------|-----------------------|------------------------------|-----------|-----------------------|----------------------|---------------------------------|--------------------------------|------------------------|
| 147 | ETPUB0_ETPUB16_ GPIO147 | P | ETPUB0 | eTPU B channel | I/O | MH | V _{DDEH6} | —/WKPCFG | —/WKPCFG | T24 |
| | | A1 | ETPUB16 | eTPU B channel (output only) | O | | | | | |
| | | A2 | — | — | — | | | | | |
| | | G | GPIO147 | GPIO | I/O | | | | | |
| 148 | ETPUB1_ETPUB17_ GPIO148 | P | ETPUB1 | eTPU B channel | I/O | MH | V _{DDEH6} | —/WKPCFG | —/WKPCFG | T25 |
| | | A1 | ETPUB17 | eTPU B channel (output only) | O | | | | | |
| | | A2 | — | — | — | | | | | |
| | | G | GPIO148 | GPIO | I/O | | | | | |
| 149 | ETPUB2_ETPUB18_ GPIO149 | P | ETPUB2 | eTPU B channel | I/O | MH | V _{DDEH6} | —/WKPCFG | —/WKPCFG | T26 |
| | | A1 | ETPUB18 | eTPU B channel (output only) | O | | | | | |
| | | A2 | — | — | — | | | | | |
| | | G | GPIO149 | GPIO | I/O | | | | | |
| 150 | ETPUB3_ETPUB19_ GPIO150 | P | ETPUB3 | eTPU B channel | I/O | MH | V _{DDEH6} | —/WKPCFG | —/WKPCFG | R23 |
| | | A1 | ETPUB19 | eTPU B channel (output only) | O | | | | | |
| | | A2 | — | — | — | | | | | |
| | | G | GPIO150 | GPIO | I/O | | | | | |
| 151 | ETPUB4_ETPUB20_ GPIO151 | P | ETPUB4 | eTPU B channel | I/O | MH | V _{DDEH6} | —/WKPCFG | —/WKPCFG | R24 |
| | | A1 | ETPUB20 | eTPU B channel (output only) | O | | | | | |
| | | A2 | — | — | — | | | | | |
| | | G | GPIO151 | GPIO | I/O | | | | | |
| 152 | ETPUB5_ETPUB21_ GPIO152 | P | ETPUB5 | eTPU B channel | I/O | MH | V _{DDEH6} | —/WKPCFG | —/WKPCFG | R25 |
| | | A1 | ETPUB21 | eTPU B channel (output only) | O | | | | | |
| | | A2 | — | — | — | | | | | |
| | | G | GPIO152 | GPIO | I/O | | | | | |

Table 3-4. Signal Properties and Muxing Summary (continued)

| GPIO/PCR ¹ | Signal Name ² | P/A/G ³ | Function ⁴ | Function Summary | Direction | Pad Type ⁵ | Voltage ⁶ | State during RESET ⁷ | State after RESET ⁸ | Package Location (416) |
|-----------------------|-----------------------------|--------------------|-----------------------|------------------------------|-----------|-----------------------|----------------------|---------------------------------|--------------------------------|------------------------|
| 153 | ETPUB6_ETPUB22_ GPIO153 | P | ETPUB6 | eTPU B channel | I/O | MH | V _{DDEH6} | —/WKPCFG | —/WKPCFG | R26 |
| | | A1 | ETPUB22 | eTPU B channel (output only) | O | | | | | |
| | | A2 | — | — | — | | | | | |
| | | G | GPIO153 | GPIO | I/O | | | | | |
| 154 | ETPUB7_ETPUB23_ GPIO154 | P | ETPUB7 | eTPU B channel | I/O | MH | V _{DDEH6} | —/WKPCFG | —/WKPCFG | P23 |
| | | A1 | ETPUB23 | eTPU B channel (output only) | O | | | | | |
| | | A2 | — | — | — | | | | | |
| | | G | GPIO154 | GPIO | I/O | | | | | |
| 155 | ETPUB8_ETPUB24_ GPIO155 | P | ETPUB8 | eTPU B channel | I/O | MH | V _{DDEH6} | —/WKPCFG | —/WKPCFG | P24 |
| | | A1 | ETPUB24 | eTPU B channel (output only) | O | | | | | |
| | | A2 | — | — | — | | | | | |
| | | G | GPIO155 | GPIO | I/O | | | | | |
| 156 | ETPUB9_ETPUB25_ GPIO156 | P | ETPUB9 | eTPU B channel | I/O | MH | V _{DDEH6} | —/WKPCFG | —/WKPCFG | P25 |
| | | A1 | ETPUB25 | eTPU B channel (output only) | O | | | | | |
| | | A2 | — | — | — | | | | | |
| | | G | GPIO156 | GPIO | I/O | | | | | |
| 157 | ETPUB10_ETPUB26_ GPIO157 | P | ETPUB10 | eTPU B channel | I/O | MH | V _{DDEH6} | —/WKPCFG | —/WKPCFG | P26 |
| | | A1 | ETPUB26 | eTPU B channel (output only) | O | | | | | |
| | | A2 | — | — | — | | | | | |
| | | G | GPIO157 | GPIO | I/O | | | | | |
| 158 | ETPUB11_ETPUB27_ GPIO158 | P | ETPUB11 | eTPU B channel | I/O | MH | V _{DDEH6} | —/WKPCFG | —/WKPCFG | N24 |
| | | A1 | ETPUB27 | eTPU B channel (output only) | O | | | | | |
| | | A2 | — | — | — | | | | | |
| | | G | GPIO158 | GPIO | I/O | | | | | |

Table 3-4. Signal Properties and Muxing Summary (continued)

| GPIO/PCR ¹ | Signal Name ² | P/A/G ³ | Function ⁴ | Function Summary | Direction | Pad Type ⁵ | Voltage ⁶ | State during RESET ⁷ | State after RESET ⁸ | Package Location (416) |
|-----------------------|-----------------------------|--------------------|-----------------------|-------------------------------|-----------|-----------------------|----------------------|---------------------------------|--------------------------------|------------------------|
| 159 | ETPUB12_ETPUB28_ GPIO159 | P | ETPUB12 | eTPU B channel | I/O | MH | V _{DDEH6} | —/WKPCFG | —/WKPCFG | N25 |
| | | A1 | ETPUB28 | eTPU B channel (output only) | O | | | | | |
| | | A2 | — | — | — | | | | | |
| | | G | GPIO159 | GPIO | I/O | | | | | |
| 160 | ETPUB13_ETPUB29_ GPIO160 | P | ETPUB13 | eTPU B channel | I/O | MH | V _{DDEH6} | —/WKPCFG | —/WKPCFG | N26 |
| | | A1 | ETPUB29 | eTPU B channel (output only) | O | | | | | |
| | | A2 | — | — | — | | | | | |
| | | G | GPIO160 | GPIO | I/O | | | | | |
| 161 | ETPUB14_ETPUB30_ GPIO161 | P | ETPUB14 | eTPU B channel | I/O | MH | V _{DDEH6} | —/WKPCFG | —/WKPCFG | M25 |
| | | A1 | ETPUB30 | eTPU B channel (output only) | O | | | | | |
| | | A2 | — | — | — | | | | | |
| | | G | GPIO161 | GPIO | I/O | | | | | |
| 162 | ETPUB15_ETPUB31_ GPIO162 | P | ETPUB15 | eTPU B channel | I/O | MH | V _{DDEH6} | —/WKPCFG | —/WKPCFG | M24 |
| | | A1 | ETPUB31 | eTPU B channel (output only) | O | | | | | |
| | | A2 | — | — | — | | | | | |
| | | G | GPIO162 | GPIO | I/O | | | | | |
| 163 | ETPUB16_PCSA1_ GPIO163 | P | ETPUB16 | eTPU B channel | I/O | MH | V _{DDEH6} | —/WKPCFG | —/WKPCFG | U26 |
| | | A1 | PCSA1 | DSPI A peripheral chip select | O | | | | | |
| | | A2 | — | — | — | | | | | |
| | | G | GPIO163 | GPIO | I/O | | | | | |
| 164 | ETPUB17_PCSA2_ GPIO164 | P | ETPUB17 | eTPU B channel | I/O | MH | V _{DDEH6} | —/WKPCFG | —/WKPCFG | U25 |
| | | A1 | PCSA2 | DSPI A peripheral chip select | O | | | | | |
| | | A2 | — | — | — | | | | | |
| | | G | GPIO164 | GPIO | I/O | | | | | |

Table 3-4. Signal Properties and Muxing Summary (continued)

| GPIO/PCR ¹ | Signal Name ² | P/A/G ³ | Function ⁴ | Function Summary | Direction | Pad Type ⁵ | Voltage ⁶ | State during RESET ⁷ | State after RESET ⁸ | Package Location (416) |
|-----------------------|---------------------------|--------------------|-----------------------|-------------------------------|-----------|-----------------------|----------------------|---------------------------------|--------------------------------|------------------------|
| 165 | ETPUB18_PCSA3_ GPIO165 | P | ETPUB18 | eTPU B channel | I/O | MH | V _{DDEH6} | —/WKPCFG | —/WKPCFG | U24 |
| | | A1 | PCSA3 | DSPI A peripheral chip select | O | | | | | |
| | | A2 | — | — | — | | | | | |
| | | G | GPIO165 | GPIO | I/O | | | | | |
| 166 | ETPUB19_PCSA4_ GPIO166 | P | ETPUB19 | eTPU B channel | I/O | MH | V _{DDEH6} | —/WKPCFG | —/WKPCFG | U23 |
| | | A1 | PCSA4 | DSPI A peripheral chip select | O | | | | | |
| | | A2 | — | — | — | | | | | |
| | | G | GPIO166 | GPIO | I/O | | | | | |
| 167 | ETPUB20_ GPIO167 | P | ETPUB20 | eTPU B channel | I/O | MH | V _{DDEH6} | —/WKPCFG | —/WKPCFG | V26 |
| | | A1 | — | — | — | | | | | |
| | | A2 | — | — | — | | | | | |
| | | G | GPIO167 | GPIO | I/O | | | | | |
| 168 | ETPUB21_ GPIO168 | P | ETPUB21 | eTPU B channel | I/O | MH | V _{DDEH6} | —/WKPCFG | —/WKPCFG | V25 |
| | | A1 | — | — | — | | | | | |
| | | A2 | — | — | — | | | | | |
| | | G | GPIO168 | GPIO | I/O | | | | | |
| 169 | ETPUB22_ GPIO169 | P | ETPUB22 | eTPU B channel | I/O | MH | V _{DDEH6} | —/WKPCFG | —/WKPCFG | V24 |
| | | A1 | — | — | — | | | | | |
| | | A2 | — | — | — | | | | | |
| | | G | GPIO169 | GPIO | I/O | | | | | |
| 170 | ETPUB23_ GPIO170 | P | ETPUB23 | eTPU B channel | I/O | MH | V _{DDEH6} | —/WKPCFG | —/WKPCFG | W26 |
| | | A1 | — | — | — | | | | | |
| | | A2 | — | — | — | | | | | |
| | | G | GPIO170 | GPIO | I/O | | | | | |

Table 3-4. Signal Properties and Muxing Summary (continued)

| GPIO/PCR ¹ | Signal Name ² | P/A/G ³ | Function ⁴ | Function Summary | Direction | Pad Type ⁵ | Voltage ⁶ | State during RESET ⁷ | State after RESET ⁸ | Package Location (416) |
|-----------------------|--------------------------|--------------------|-----------------------|------------------|-----------|-----------------------|----------------------|---------------------------------|--------------------------------|------------------------|
| 171 | ETPUB24_ GPIO171 | P | ETPUB24 | eTPU B channel | I/O | MH | V _{DDEH6} | —/WKPCFG | —/WKPCFG | W25 |
| | | A1 | — | — | — | | | | | |
| | | A2 | — | — | — | | | | | |
| | | G | GPIO171 | GPIO | I/O | | | | | |
| 172 | ETPUB25_ GPIO172 | P | ETPUB25 | eTPU B channel | I/O | MH | V _{DDEH6} | —/WKPCFG | —/WKPCFG | W24 |
| | | A1 | — | — | — | | | | | |
| | | A2 | — | — | — | | | | | |
| | | G | GPIO172 | GPIO | I/O | | | | | |
| 173 | ETPUB26_ GPIO173 | P | ETPUB26 | eTPU B channel | I/O | MH | V _{DDEH6} | —/WKPCFG | —/WKPCFG | V23 |
| | | A1 | — | — | — | | | | | |
| | | A2 | — | — | — | | | | | |
| | | G | GPIO173 | GPIO | I/O | | | | | |
| 174 | ETPUB27_ GPIO174 | P | ETPUB27 | eTPU B channel | I/O | MH | V _{DDEH6} | —/WKPCFG | —/WKPCFG | Y25 |
| | | A1 | — | — | — | | | | | |
| | | A2 | — | — | — | | | | | |
| | | G | GPIO174 | GPIO | I/O | | | | | |
| 175 | ETPUB28_ GPIO175 | P | ETPUB28 | eTPU B channel | I/O | MH | V _{DDEH6} | —/WKPCFG | —/WKPCFG | Y24 |
| | | A1 | — | — | — | | | | | |
| | | A2 | — | — | — | | | | | |
| | | G | GPIO175 | GPIO | I/O | | | | | |
| 176 | ETPUB29_ GPIO176 | P | ETPUB29 | eTPU B channel | I/O | MH | V _{DDEH6} | —/WKPCFG | —/WKPCFG | Y23 |
| | | A1 | — | — | — | | | | | |
| | | A2 | — | — | — | | | | | |
| | | G | GPIO176 | GPIO | I/O | | | | | |

Table 3-4. Signal Properties and Muxing Summary (continued)

| GPIO/PCR ¹ | Signal Name ² | P/A/G ³ | Function ⁴ | Function Summary | Direction | Pad Type ⁵ | Voltage ⁶ | State during RESET ⁷ | State after RESET ⁸ | Package Location (416) |
|---------------------------|----------------------------------|--------------------|-----------------------|------------------|-----------|-----------------------|----------------------|---------------------------------|--------------------------------|------------------------|
| 177 | ETPUB30_ GPIO177 | P | ETPUB30 | eTPU B channel | I/O | MH | V _{DDEH6} | —/WKPCFG | —/WKPCFG | AA24 |
| | | A1 | — | — | — | | | | | |
| | | A2 | — | — | — | | | | | |
| | | G | GPIO177 | GPIO | I/O | | | | | |
| 178 | ETPUB31_ GPIO178 | P | ETPUB31 | eTPU B channel | I/O | MH | V _{DDEH6} | —/WKPCFG | —/WKPCFG | AB24 |
| | | A1 | — | — | — | | | | | |
| | | A2 | — | — | — | | | | | |
| | | G | GPIO178 | GPIO | I/O | | | | | |
| GPIO, IRQ, FlexRay | | | | | | | | | | |
| 440 | TCRCLKC_ GPIO440 ⁹ | P | — | — | — | MH | V _{DDEH7} | —/Up | —/Up | B26 |
| | | A1 | — | — | — | | | | | |
| | | A2 | — | — | — | | | | | |
| | | G | GPIO440 | GPIO | I/O | | | | | |
| 441 | ETPUC0_ GPIO441 ⁹ | P | — | — | — | MH | V _{DDEH7} | —/WKPCFG | —/WKPCFG | C25 |
| | | A1 | — | — | — | | | | | |
| | | A2 | — | — | — | | | | | |
| | | G | GPIO441 | GPIO | I/O | | | | | |
| 442 | ETPUC1_ GPIO442 ⁹ | P | — | — | — | MH | V _{DDEH7} | —/WKPCFG | —/WKPCFG | C26 |
| | | A1 | — | — | — | | | | | |
| | | A2 | — | — | — | | | | | |
| | | G | GPIO442 | GPIO | I/O | | | | | |
| 443 | ETPUC2_ GPIO443 ⁹ | P | — | — | — | MH | V _{DDEH7} | —/WKPCFG | —/WKPCFG | D25 |
| | | A1 | — | — | — | | | | | |
| | | A2 | — | — | — | | | | | |
| | | G | GPIO443 | GPIO | I/O | | | | | |

Table 3-4. Signal Properties and Muxing Summary (continued)

| GPIO/PCR ¹ | Signal Name ² | P/A/G ³ | Function ⁴ | Function Summary | Direction | Pad Type ⁵ | Voltage ⁶ | State during RESET ⁷ | State after RESET ⁸ | Package Location (416) |
|-----------------------|---------------------------------|--------------------|-----------------------|------------------|-----------|-----------------------|----------------------|---------------------------------|--------------------------------|------------------------|
| 444 | ETPUC3_ GPIO444 ⁹ | P | — | — | — | MH | V _{DDEH7} | —/WKPCFG | —/WKPCFG | D26 |
| | | A1 | — | — | — | | | | | |
| | | A2 | — | — | — | | | | | |
| | | G | GPIO444 | GPIO | I/O | | | | | |
| 445 | ETPUC4_ GPIO445 ⁹ | P | — | — | — | MH | V _{DDEH7} | —/WKPCFG | —/WKPCFG | E24 |
| | | A1 | — | — | — | | | | | |
| | | A2 | — | — | — | | | | | |
| | | G | GPIO445 | GPIO | I/O | | | | | |
| 446 | ETPUC5_ GPIO446 ⁹ | P | — | — | I/O | MH | V _{DDEH7} | —/WKPCFG | —/WKPCFG | E25 |
| | | A1 | — | — | — | | | | | |
| | | A2 | — | — | — | | | | | |
| | | G | GPIO446 | GPIO | I/O | | | | | |
| 447 | ETPUC6_ GPIO447 ⁹ | P | — | — | I/O | MH | V _{DDEH7} | —/WKPCFG | —/WKPCFG | E26 |
| | | A1 | — | — | — | | | | | |
| | | A2 | — | — | — | | | | | |
| | | G | GPIO447 | GPIO | I/O | | | | | |
| 448 | ETPUC7_ GPIO448 ⁹ | P | — | — | I/O | MH | V _{DDEH7} | —/WKPCFG | —/WKPCFG | F23 |
| | | A1 | — | — | — | | | | | |
| | | A2 | — | — | — | | | | | |
| | | G | GPIO448 | GPIO | I/O | | | | | |
| 449 | ETPUC8_ GPIO449 ⁹ | P | — | — | I/O | MH | V _{DDEH7} | —/WKPCFG | —/WKPCFG | F24 |
| | | A1 | — | — | — | | | | | |
| | | A2 | — | — | — | | | | | |
| | | G | GPIO449 | GPIO | I/O | | | | | |

Table 3-4. Signal Properties and Muxing Summary (continued)

| GPIO/PCR ¹ | Signal Name ² | P/A/G ³ | Function ⁴ | Function Summary | Direction | Pad Type ⁵ | Voltage ⁶ | State during RESET ⁷ | State after RESET ⁸ | Package Location (416) |
|-----------------------|---|--------------------|-----------------------|----------------------------|-----------|-----------------------|----------------------|---------------------------------|--------------------------------|------------------------|
| 450 | ETPUC9_IRQ0_ GPIO450 ⁹ | P | — | — | — | MH | V _{DDEH7} | —/WKPCFG | —/WKPCFG | F25 |
| | | A1 | IRQ0 | External interrupt request | I | | | | | |
| | | A2 | — | — | — | | | | | |
| | | G | GPIO450 | GPIO | I/O | | | | | |
| 451 | ETPUC10_IRQ1_ GPIO451 ⁹ | P | — | — | — | MH | V _{DDEH7} | —/WKPCFG | —/WKPCFG | F26 |
| | | A1 | IRQ1 | External interrupt request | I | | | | | |
| | | A2 | — | — | — | | | | | |
| | | G | GPIO451 | GPIO | I/O | | | | | |
| 452 | ETPUC11_IRQ2_ GPIO452 ⁹ | P | — | — | — | MH | V _{DDEH7} | —/WKPCFG | —/WKPCFG | G23 |
| | | A1 | IRQ2 | External interrupt request | I | | | | | |
| | | A2 | — | — | — | | | | | |
| | | G | GPIO452 | GPIO | I/O | | | | | |
| 453 | ETPUC12_IRQ3_ GPIO453 ⁹ | P | — | — | — | MH | V _{DDEH7} | —/WKPCFG | —/WKPCFG | G24 |
| | | A1 | IRQ3 | External interrupt request | I | | | | | |
| | | A2 | — | — | — | | | | | |
| | | G | GPIO453 | GPIO | I/O | | | | | |
| 454 | ETPUC13_3_IRQ4_ GPIO454 ⁹ | P | — | — | — | MH | V _{DDEH7} | —/WKPCFG | —/WKPCFG | G25 |
| | | A1 | IRQ4 | External interrupt request | I | | | | | |
| | | A2 | — | — | — | | | | | |
| | | G | GPIO454 | GPIO | I/O | | | | | |
| 455 | ETPUC14_4_IRQ5_ GPIO455 ⁹ | P | — | — | — | MH | V _{DDEH7} | —/WKPCFG | —/WKPCFG | G26 |
| | | A1 | IRQ5 | External interrupt request | I | | | | | |
| | | A2 | — | — | — | | | | | |
| | | G | GPIO455 | GPIO | I/O | | | | | |

Table 3-4. Signal Properties and Muxing Summary (continued)

| GPIO/PCR ¹ | Signal Name ² | P/A/G ³ | Function ⁴ | Function Summary | Direction | Pad Type ⁵ | Voltage ⁶ | State during RESET ⁷ | State after RESET ⁸ | Package Location (416) |
|-----------------------|---|--------------------|-----------------------|---------------------------|-----------|-----------------------|----------------------|---------------------------------|--------------------------------|------------------------|
| 456 | ETPUC15_ GPIO456 ⁹ | P | — | — | — | MH | V _{DDEH7} | —/WKPCFG | —/WKPCFG | H23 |
| | | A1 | — | — | — | | | | | |
| | | A2 | — | — | — | | | | | |
| | | G | GPIO456 | GPIO | I/O | | | | | |
| 457 | ETPUC16_FR_A_TX_ GPIO457 ⁹ | P | — | — | — | MH | V _{DDEH7} | —/WKPCFG | —/WKPCFG | H24 |
| | | A1 | FR_A_TX | FlexRay A transfer | O | | | | | |
| | | A2 | — | — | — | | | | | |
| | | G | GPIO457 | GPIO | I/O | | | | | |
| 458 | ETPUC17_FR_A_RX_ GPIO458 ⁹ | P | — | — | — | MH | V _{DDEH7} | —/WKPCFG | —/WKPCFG | H25 |
| | | A1 | FR_A_RX | FlexRay A receive | I | | | | | |
| | | A2 | — | — | — | | | | | |
| | | G | GPIO458 | GPIO | I/O | | | | | |
| 459 | ETPUC18_FR_A_TX_EN_ GPIO459 ⁹ | P | — | — | — | MH | V _{DDEH7} | —/WKPCFG | —/WKPCFG | H26 |
| | | A1 | FR_A_TX_EN | FlexRay A transfer enable | O | | | | | |
| | | A2 | — | — | — | | | | | |
| | | G | GPIO459 | GPIO | I/O | | | | | |
| 460 | ETPUC19_TXDA_ GPIO460 ⁹ | P | — | — | — | MH | V _{DDEH7} | —/WKPCFG | —/WKPCFG | J23 |
| | | A1 | TXDA | eSCI A transmit | O | | | | | |
| | | A2 | — | — | — | | | | | |
| | | G | GPIO460 | GPIO | I/O | | | | | |
| 461 | ETPUC20_RXDA_ GPIO461 ⁹ | P | — | — | — | MH | V _{DDEH7} | —/WKPCFG | —/WKPCFG | J24 |
| | | A1 | RXDA | eSCI A receive | I | | | | | |
| | | A2 | — | — | — | | | | | |
| | | G | GPIO461 | GPIO | I/O | | | | | |

Table 3-4. Signal Properties and Muxing Summary (continued)

| GPIO/PCR ¹ | Signal Name ² | P/A/G ³ | Function ⁴ | Function Summary | Direction | Pad Type ⁵ | Voltage ⁶ | State during RESET ⁷ | State after RESET ⁸ | Package Location (416) |
|-----------------------|--|--------------------|-----------------------|-------------------------------|-----------|-----------------------|----------------------|---------------------------------|--------------------------------|------------------------|
| 462 | ETPUC21_TXDB_ GPIO462 ⁹ | P | — | — | — | MH | V _{DDEH7} | —/WKPCFG | —/WKPCFG | J25 |
| | | A1 | TXDB | eSCI B transmit | O | | | | | |
| | | A2 | — | — | — | | | | | |
| | | G | GPIO462 | GPIO | I/O | | | | | |
| 463 | ETPUC22_RXDB_ GPIO463 ⁹ | P | — | — | — | MH | V _{DDEH7} | —/WKPCFG | —/WKPCFG | J26 |
| | | A1 | RXDB | eSCI B receive | I | | | | | |
| | | A2 | — | — | — | | | | | |
| | | G | GPIO463 | GPIO | I/O | | | | | |
| 464 | ETPUC23_PCSD5_ GPIO464 ⁹ | P | — | — | — | MH | V _{DDEH7} | —/WKPCFG | —/WKPCFG | K23 |
| | | A1 | PCSD5 | DSPI D peripheral chip select | O | | | | | |
| | | A2 | MAA0 | ADC A Mux Address 0 | O | | | | | |
| | | A3 | MAB0 | ADC B Mux Address 0 | O | | | | | |
| | | G | GPIO464 | GPIO | I/O | | | | | |
| 465 | ETPUC24_PCSD4_ GPIO465 ⁹ | P | — | — | — | MH | V _{DDEH7} | —/WKPCFG | —/WKPCFG | K24 |
| | | A1 | PCSD4 | DSPI D peripheral chip select | O | | | | | |
| | | A2 | MAA1 | ADC A Mux Address 1 | O | | | | | |
| | | A4 | MAB1 | ADC B Mux Address 1 | O | | | | | |
| | | G | GPIO465 | GPIO | I/O | | | | | |
| 466 | ETPUC25_PCSD3_ GPIO466 ⁹ | P | — | — | — | MH | V _{DDEH7} | —/WKPCFG | —/WKPCFG | K25 |
| | | A1 | PCSD3 | DSPI D peripheral chip select | O | | | | | |
| | | A2 | MAA2 | ADC A Mux Address 2 | O | | | | | |
| | | A3 | MAB2 | ADC B Mux Address 2 | O | | | | | |
| | | G | GPIO466 | GPIO | I/O | | | | | |

Table 3-4. Signal Properties and Muxing Summary (continued)

| GPIO/PCR ¹ | Signal Name ² | P/A/G ³ | Function ⁴ | Function Summary | Direction | Pad Type ⁵ | Voltage ⁶ | State during RESET ⁷ | State after RESET ⁸ | Package Location (416) |
|-----------------------|--|--------------------|-----------------------|-------------------------------|-----------|-----------------------|----------------------|---------------------------------|--------------------------------|------------------------|
| 467 | ETPUC26_PCSD2_ GPIO467 ⁹ | P | — | — | — | MH | V _{DDEH7} | —/WKPCFG | —/WKPCFG | K26 |
| | | A1 | PCSD2 | DSPI D peripheral chip select | O | | | | | |
| | | A2 | — | — | — | | | | | |
| | | G | GPIO467 | GPIO | I/O | | | | | |
| 468 | ETPUC27_PCSD1_ GPIO468 ⁹ | P | — | — | — | MH | V _{DDEH7} | —/WKPCFG | —/WKPCFG | L23 |
| | | A1 | PCSD1 | DSPI D peripheral chip select | O | | | | | |
| | | A2 | — | — | — | | | | | |
| | | G | GPIO468 | GPIO | I/O | | | | | |
| 469 | ETPUC28_PCSD0_ GPIO469 ⁹ | P | — | — | — | MH | V _{DDEH7} | —/WKPCFG | —/WKPCFG | L24 |
| | | A1 | PCSD0 | DSPI D peripheral chip select | I/O | | | | | |
| | | A2 | — | — | — | | | | | |
| | | G | GPIO469 | GPIO | I/O | | | | | |
| 470 | ETPUC29_SCKD_ GPIO470 ⁹ | P | — | — | — | MH | V _{DDEH7} | —/WKPCFG | —/WKPCFG | L25 |
| | | A1 | SCKD | DSPI D clock | I/O | | | | | |
| | | A2 | — | — | — | | | | | |
| | | G | GPIO470 | GPIO | I/O | | | | | |
| 471 | ETPUC30_SOUTD_ GPIO471 ⁹ | P | — | — | — | MH | V _{DDEH7} | —/WKPCFG | —/WKPCFG | L26 |
| | | A1 | SOUTD | DSPI D data output | O | | | | | |
| | | A2 | — | — | — | | | | | |
| | | G | GPIO471 | GPIO | I/O | | | | | |
| 472 | ETPUC31_SIND_ GPIO472 ⁹ | P | — | — | — | MH | V _{DDEH7} | —/WKPCFG | —/WKPCFG | M23 |
| | | A1 | SIND | DSPI D data input | I | | | | | |
| | | A2 | — | — | — | | | | | |
| | | G | GPIO472 | GPIO | I/O | | | | | |
| eMIOS | | | | | | | | | | |

Table 3-4. Signal Properties and Muxing Summary (continued)

| GPIO/PCR ¹ | Signal Name ² | P/A/G ³ | Function ⁴ | Function Summary | Direction | Pad Type ⁵ | Voltage ⁶ | State during RESET ⁷ | State after RESET ⁸ | Package Location (416) |
|-----------------------|---------------------------|--------------------|-----------------------|------------------|-----------|-----------------------|----------------------|---------------------------------|--------------------------------|------------------------|
| 179 | EMIOS0_ETPUA0_ GPIO179 | P | EMIOS0 | eMIOS channel | I/O | MH | V _{DDEH4} | —/WKPCFG | —/WKPCFG | AE10 |
| | | A1 | ETPUA0 | eTPU A channel | O | | | | | |
| | | A2 | — | — | — | | | | | |
| | | G | GPIO179 | GPIO | I/O | | | | | |
| 180 | EMIOS1_ETPUA1_ GPIO180 | P | EMIOS1 | eMIOS channel | I/O | MH | V _{DDEH4} | —/WKPCFG | —/WKPCFG | AF10 |
| | | A1 | ETPUA1 | eTPU A channel | O | | | | | |
| | | A2 | — | — | — | | | | | |
| | | G | GPIO180 | GPIO | I/O | | | | | |
| 181 | EMIOS2_ETPUA2_ GPIO181 | P | EMIOS2 | eMIOS channel | I/O | MH | V _{DDEH4} | —/WKPCFG | —/WKPCFG | AD11 |
| | | A1 | ETPUA2 | eTPU A channel | O | | | | | |
| | | A2 | — | — | — | | | | | |
| | | G | GPIO181 | GPIO | I/O | | | | | |
| 182 | EMIOS3_ETPUA3_ GPIO182 | P | EMIOS3 | eMIOS channel | I/O | MH | V _{DDEH4} | —/WKPCFG | —/WKPCFG | AE11 |
| | | A1 | ETPUA3 | eTPU A channel | O | | | | | |
| | | A2 | — | — | — | | | | | |
| | | G | GPIO182 | GPIO | I/O | | | | | |
| 183 | EMIOS4_ETPUA4_ GPIO183 | P | EMIOS4 | eMIOS channel | I/O | MH | V _{DDEH4} | —/WKPCFG | —/WKPCFG | AF11 |
| | | A1 | ETPUA4 | eTPU A channel | O | | | | | |
| | | A2 | — | — | — | | | | | |
| | | G | GPIO183 | GPIO | I/O | | | | | |
| 184 | EMIOS5_ETPUA5_ GPIO184 | P | EMIOS5 | eMIOS channel | I/O | MH | V _{DDEH4} | —/WKPCFG | —/WKPCFG | AD12 |
| | | A1 | ETPUA5 | eTPU A channel | O | | | | | |
| | | A2 | — | — | — | | | | | |
| | | G | GPIO184 | GPIO | I/O | | | | | |

Table 3-4. Signal Properties and Muxing Summary (continued)

| GPIO/PCR ¹ | Signal Name ² | P/A/G ³ | Function ⁴ | Function Summary | Direction | Pad Type ⁵ | Voltage ⁶ | State during RESET ⁷ | State after RESET ⁸ | Package Location (416) |
|-----------------------|---------------------------|--------------------|-----------------------|-------------------|-----------|-----------------------|----------------------|---------------------------------|--------------------------------|------------------------|
| 185 | EMIOS6_ETPUA6_ GPIO185 | P | EMIOS6 | eMIOS channel | I/O | MH | V _{DDEH4} | —/WKPCFG | —/WKPCFG | AE12 |
| | | A1 | ETPUA6 | eTPU A channel | O | | | | | |
| | | A2 | — | — | — | | | | | |
| | | G | GPIO185 | GPIO | I/O | | | | | |
| 186 | EMIOS7_ETPUA7_ GPIO186 | P | EMIOS7 | eMIOS channel | I/O | MH | V _{DDEH4} | —/WKPCFG | —/WKPCFG | AF12 |
| | | A1 | ETPUA7 | eTPU A channel | O | | | | | |
| | | A2 | — | — | — | | | | | |
| | | G | GPIO186 | GPIO | I/O | | | | | |
| 187 | EMIOS8_ETPUA8_ GPIO187 | P | EMIOS8 | eMIOS channel | I/O | MH | V _{DDEH4} | —/WKPCFG | —/WKPCFG | AC13 |
| | | A1 | ETPUA8 | eTPU A channel | O | | | | | |
| | | A2 | — | — | — | | | | | |
| | | G | GPIO187 | GPIO | I/O | | | | | |
| 188 | EMIOS9_ETPUA9_ GPIO188 | P | EMIOS9 | eMIOS channel | I/O | MH | V _{DDEH4} | —/WKPCFG | —/WKPCFG | AD13 |
| | | A1 | ETPUA9 | eTPU A channel | O | | | | | |
| | | A2 | — | — | — | | | | | |
| | | G | GPIO188 | GPIO | I/O | | | | | |
| 189 | EMIOS10_SCKD_ GPIO189 | P | EMIOS10 | eMIOS channel | I/O | MH | V _{DDEH4} | —/WKPCFG | —/WKPCFG | AE13 |
| | | A1 | SCKD | DSPI D clock | O | | | | | |
| | | A2 | — | — | — | | | | | |
| | | G | GPIO189 | GPIO | I/O | | | | | |
| 190 | EMIOS11_SIND_ GPIO190 | P | EMIOS11 | eMIOS channel | I/O | MH | V _{DDEH4} | —/WKPCFG | —/WKPCFG | AF13 |
| | | A1 | SIND | DSPI D data input | I | | | | | |
| | | A2 | — | — | — | | | | | |
| | | G | GPIO190 | GPIO | I/O | | | | | |

Table 3-4. Signal Properties and Muxing Summary (continued)

| GPIO/PCR ¹ | Signal Name ² | P/A/G ³ | Function ⁴ | Function Summary | Direction | Pad Type ⁵ | Voltage ⁶ | State during RESET ⁷ | State after RESET ⁸ | Package Location (416) |
|-----------------------|----------------------------|--------------------|-----------------------|----------------------------|-----------|-----------------------|----------------------|---------------------------------|--------------------------------|------------------------|
| 191 | EMIOS12_SOUTC_ GPIO191 | P | EMIOS12 | eMIOS channel | O | MH | V _{DDEH4} | —/WKPCFG | —/WKPCFG | AF14 |
| | | A1 | SOUTC | DSPI C data output | O | | | | | |
| | | A2 | — | — | — | | | | | |
| | | G | GPIO191 | GPIO | I/O | | | | | |
| 192 | EMIOS13_SOUTD_ GPIO192 | P | EMIOS13 | eMIOS channel | O | MH | V _{DDEH4} | —/WKPCFG | —/WKPCFG | AE14 |
| | | A1 | SOUTD | DSPI D data output | O | | | | | |
| | | A2 | — | — | — | | | | | |
| | | G | GPIO192 | GPIO | I/O | | | | | |
| 193 | EMIOS14_IRQ0_ GPIO193 | P | EMIOS14 | eMIOS channel | O | MH | V _{DDEH4} | —/WKPCFG | —/WKPCFG | AC14 |
| | | A1 | IRQ0 | External interrupt request | I | | | | | |
| | | A2 | CNTXD | FlexCAN D transmit | O | | | | | |
| | | G | GPIO193 | GPIO | I/O | | | | | |
| 194 | EMIOS15_IRQ1_ GPIO194 | P | EMIOS15 | eMIOS channel | O | MH | V _{DDEH4} | —/WKPCFG | —/WKPCFG | AD14 |
| | | A1 | IRQ1 | External interrupt request | I | | | | | |
| | | A2 | CNRXD | FlexCAN D receive | I | | | | | |
| | | G | GPIO194 | GPIO | I/O | | | | | |
| 195 | EMIOS16_ETPUB0_ GPIO195 | P | EMIOS16 | eMIOS channel | I/O | MH | V _{DDEH4} | —/WKPCFG | —/WKPCFG | AF15 |
| | | A1 | ETPUB0 | eTPU B channel | O | | | | | |
| | | A2 | FR_DBG[3] | FlexRay debug | O | | | | | |
| | | G | GPIO195 | GPIO | I/O | | | | | |
| 196 | EMIOS17_ETPUB1_ GPIO196 | P | EMIOS17 | eMIOS channel | I/O | MH | V _{DDEH4} | —/WKPCFG | —/WKPCFG | AE15 |
| | | A1 | ETPUB1 | eTPU B channel | O | | | | | |
| | | A2 | FR_DBG[2] | FlexRay debug | O | | | | | |
| | | G | GPIO196 | GPIO | I/O | | | | | |

Table 3-4. Signal Properties and Muxing Summary (continued)

| GPIO/PCR ¹ | Signal Name ² | P/A/G ³ | Function ⁴ | Function Summary | Direction | Pad Type ⁵ | Voltage ⁶ | State during RESET ⁷ | State after RESET ⁸ | Package Location (416) |
|-----------------------|----------------------------|--------------------|-----------------------|------------------|-----------|-----------------------|----------------------|---------------------------------|--------------------------------|------------------------|
| 197 | EMIOS18_ETPUB2_ GPIO197 | P | EMIOS18 | eMIOS channel | I/O | MH | V _{DDEH4} | —/WKPCFG | —/WKPCFG | AC15 |
| | | A1 | ETPUB2 | eTPU B channel | O | | | | | |
| | | A2 | FR_DBG[1] | FlexRay debug | O | | | | | |
| | | G | GPIO197 | GPIO | I/O | | | | | |
| 198 | EMIOS19_ETPUB3_ GPIO198 | P | EMIOS19 | eMIOS channel | I/O | MH | V _{DDEH4} | —/WKPCFG | —/WKPCFG | AD15 |
| | | A1 | ETPUB3 | eTPU B channel | O | | | | | |
| | | A2 | FR_DBG[0] | FlexRay debug | O | | | | | |
| | | G | GPIO198 | GPIO | I/O | | | | | |
| 199 | EMIOS20_ETPUB4_ GPIO199 | P | EMIOS20 | eMIOS channel | I/O | MH | V _{DDEH4} | —/WKPCFG | —/WKPCFG | AF16 |
| | | A1 | ETPUB4 | eTPU B channel | O | | | | | |
| | | A2 | — | — | — | | | | | |
| | | G | GPIO199 | GPIO | I/O | | | | | |
| 200 | EMIOS21_ETPUB5_ GPIO200 | P | EMIOS21 | eMIOS channel | I/O | MH | V _{DDEH4} | —/WKPCFG | —/WKPCFG | AE16 |
| | | A1 | ETPUB5 | eTPU B channel | O | | | | | |
| | | A2 | — | — | — | | | | | |
| | | G | GPIO200 | GPIO | I/O | | | | | |
| 201 | EMIOS22_ETPUB6_ GPIO201 | P | EMIOS22 | eMIOS channel | I/O | MH | V _{DDEH4} | —/WKPCFG | —/WKPCFG | AC16 |
| | | A1 | ETPUB6 | eTPU B channel | O | | | | | |
| | | A2 | — | — | — | | | | | |
| | | G | GPIO201 | GPIO | I/O | | | | | |
| 202 | EMIOS23_ETPUB7_ GPIO202 | P | EMIOS23 | eMIOS channel | I/O | MH | V _{DDEH4} | —/WKPCFG | —/WKPCFG | AD16 |
| | | A1 | ETPUB7 | eTPU B channel | O | | | | | |
| | | A2 | — | — | — | | | | | |
| | | G | GPIO202 | GPIO | I/O | | | | | |

Table 3-4. Signal Properties and Muxing Summary (continued)

| GPIO/PCR ¹ | Signal Name ² | P/A/G ³ | Function ⁴ | Function Summary | Direction | Pad Type ⁵ | Voltage ⁶ | State during RESET ⁷ | State after RESET ⁸ | Package Location (416) |
|-----------------------|---------------------------|--------------------|-----------------------|-------------------------------|-----------|-----------------------|----------------------|---------------------------------|--------------------------------|------------------------|
| 203 | EMIOS24_PCSB0_ GPIO203 | P | EMIOS24 | eMIOS channel | I/O | MH | V _{DDEH4} | —/WKPCFG | —/WKPCFG | AF17 |
| | | A1 | PCSB0 | DSPI B peripheral chip select | I/O | | | | | |
| | | A2 | — | — | — | | | | | |
| | | G | GPIO203 | GPIO | I/O | | | | | |
| 204 | EMIOS25_PCSB1_ GPIO204 | P | EMIOS25 | eMIOS channel | I/O | MH | V _{DDEH4} | —/WKPCFG | —/WKPCFG | AE17 |
| | | A1 | PCSB1 | DSPI B peripheral chip select | O | | | | | |
| | | A2 | — | — | — | | | | | |
| | | G | GPIO204 | GPIO | I/O | | | | | |
| 432 | EMIOS26_PCSB2_ GPIO432 | P | EMIOS26 | eMIOS channel | I/O | MH | V _{DDEH4} | —/WKPCFG | —/WKPCFG | AD17 |
| | | A1 | PCSB2 | DSPI B peripheral chip select | O | | | | | |
| | | A2 | — | — | — | | | | | |
| | | G | GPIO432 | GPIO | I/O | | | | | |
| 433 | EMIOS27_PCSB3_ GPIO433 | P | EMIOS27 | eMIOS channel | I/O | MH | V _{DDEH4} | —/WKPCFG | —/WKPCFG | AC17 |
| | | A1 | PCSB3 | DSPI B peripheral chip select | O | | | | | |
| | | A2 | — | — | — | | | | | |
| | | G | GPIO433 | GPIO | I/O | | | | | |
| 434 | EMIOS28_PCSC0_ GPIO434 | P | EMIOS28 | eMIOS channel | I/O | MH | V _{DDEH4} | —/WKPCFG | —/WKPCFG | AF18 |
| | | A1 | PCSC0 | DSPI C peripheral chip select | I/O | | | | | |
| | | A2 | — | — | — | | | | | |
| | | G | GPIO434 | GPIO | I/O | | | | | |
| 435 | EMIOS29_PCSC1_ GPIO435 | P | EMIOS29 | eMIOS channel | I/O | MH | V _{DDEH4} | —/WKPCFG | —/WKPCFG | AE18 |
| | | A1 | PCSC1 | DSPI C peripheral chip select | O | | | | | |
| | | A2 | — | — | — | | | | | |
| | | G | GPIO435 | GPIO | I/O | | | | | |

Table 3-4. Signal Properties and Muxing Summary (continued)

| GPIO/PCR ¹ | Signal Name ² | P/A/G ³ | Function ⁴ | Function Summary | Direction | Pad Type ⁵ | Voltage ⁶ | State during RESET ⁷ | State after RESET ⁸ | Package Location (416) |
|-----------------------|---------------------------|--------------------|-----------------------|-------------------------------|-----------|-----------------------|----------------------|---------------------------------|--------------------------------|------------------------|
| 436 | EMIOS30_PCSC2_ GPIO436 | P | EMIOS30 | eMIOS channel | I/O | MH | V _{DDEH4} | —/WKPCFG | —/WKPCFG | AD18 |
| | | A1 | PCSC2 | DSPI C peripheral chip select | O | | | | | |
| | | A2 | — | — | — | | | | | |
| | | G | GPIO436 | GPIO | I/O | | | | | |
| 437 | EMIOS31_PCSC5_ GPIO437 | P | EMIOS31 | eMIOS channel | I/O | MH | V _{DDEH4} | —/WKPCFG | —/WKPCFG | AC18 |
| | | A1 | PCSC5 | DSPI C peripheral chip select | O | | | | | |
| | | A2 | — | — | — | | | | | |
| | | G | GPIO437 | GPIO | I/O | | | | | |
| eQADC | | | | | | | | | | |
| — | ANA0 | P | ANA0 ¹⁰ | eQADC A analog input | I | AE/up-down | V _{DDA_A1} | ANA0 | ANA0 | A4 |
| — | ANA1 | P | ANA1 ¹⁰ | eQADC A analog input | I | AE/up-down | V _{DDA_A1} | ANA1 | ANA1 | B5 |
| — | ANA2 | P | ANA2 ¹⁰ | eQADC A analog input | I | AE/up-down | V _{DDA_A1} | ANA2 | ANA2 | C5 |
| — | ANA3 | P | ANA3 ¹⁰ | eQADC A analog input | I | AE/up-down | V _{DDA_A1} | ANA3 | ANA3 | D6 |
| — | ANA4 | P | ANA4 ¹⁰ | eQADC A analog input | I | AE/up-down | V _{DDA_A1} | ANA4 | ANA4 | A5 |
| — | ANA5 | P | ANA5 ¹⁰ | eQADC A analog input | I | AE/up-down | V _{DDA_A1} | ANA5 | ANA5 | B6 |
| — | ANA6 | P | ANA6 ¹⁰ | eQADC A analog input | I | AE/up-down | V _{DDA_A1} | ANA6 | ANA6 | C6 |
| — | ANA7 | P | ANA7 ¹⁰ | eQADC A analog input | I | AE/up-down | V _{DDA_A1} | ANA7 | ANA7 | D7 |
| — | ANA8 | P | ANA8 | eQADC A analog input | I | AE | V _{DDA_A1} | ANA8 | ANA8 | A6 |
| — | ANA9 | P | ANA9 | eQADC A analog input | I | AE | V _{DDA_A1} | ANA9 | ANA9 | C7 |
| — | ANA10 | P | ANA10 | eQADC A analog input | I | AE | V _{DDA_A1} | ANA10 | ANA10 | B7 |

Table 3-4. Signal Properties and Muxing Summary (continued)

| GPIO/PCR ¹ | Signal Name ² | P/A/G ³ | Function ⁴ | Function Summary | Direction | Pad Type ⁵ | Voltage ⁶ | State during RESET ⁷ | State after RESET ⁸ | Package Location (416) |
|-----------------------|--------------------------|--------------------|-----------------------|-----------------------------------|-----------|-----------------------|----------------------|---------------------------------|--------------------------------|------------------------|
| — | ANA11 | P | ANA11 | eQADC A analog input | I | AE | V _{DDA_A1} | ANA11 | ANA11 | A7 |
| — | ANA12 | P | ANA12 | eQADC A analog input | I | AE | V _{DDA_A1} | ANA12 | ANA12 | D8 |
| — | ANA13 | P | ANA13 | eQADC A analog input | I | AE | V _{DDA_A1} | ANA13 | ANA13 | C8 |
| — | ANA14 | P | ANA14 | eQADC A analog input | I | AE | V _{DDA_A1} | ANA14 | ANA14 | B8 |
| — | ANA15 | P | ANA15 | eQADC A analog input | I | AE | V _{DDA_A1} | ANA15 | ANA15 | A8 |
| — | ANA16 | P | ANA16 | eQADC A analog input | I | AE | V _{DDA_A1} | ANA16 | ANA16 | D9 |
| — | ANA17 | P | ANA17 | eQADC A analog input | I | AE | V _{DDA_A1} | ANA17 | ANA17 | C9 |
| — | ANA18 | P | ANA18 | eQADC A analog input | I | AE | V _{DDA_A1} | ANA18 | ANA18 | D10 |
| — | ANA19 | P | ANA19 | eQADC A analog input | I | AE | V _{DDA_A1} | ANA19 | ANA19 | C10 |
| — | ANA20 | P | ANA20 | eQADC A analog input | I | AE | V _{DDA_A1} | ANA20 | ANA20 | D11 |
| — | ANA21 | P | ANA21 | eQADC A analog input | I | AE | V _{DDA_A1} | ANA21 | ANA21 | C11 |
| — | ANA22 | P | ANA22 | eQADC A analog input | I | AE | V _{DDA_A1} | ANA22 | ANA22 | D12 |
| — | ANA23 | P | ANA23 | eQADC A analog input | I | AE | V _{DDA_A1} | ANA23 | ANA23 | C12 |
| — | AN24 | P | AN24 | eQADC A and B shared analog input | I | AE | V _{DDA_A0} | AN24 | AN24 | B12 |
| — | AN25 | P | AN25 | eQADC A and B shared analog input | I | AE | V _{DDA_A0} | AN25 | AN25 | D13 |
| — | AN26 | P | AN26 | eQADC A and B shared analog input | I | AE | V _{DDA_A0} | AN26 | AN26 | C13 |
| — | AN27 | P | AN27 | eQADC A and B shared analog input | I | AE | V _{DDA_A0} | AN27 | AN27 | B13 |
| — | AN28 | P | AN28 | eQADC A and B shared analog input | I | AE | V _{DDA_A0} | AN28 | AN28 | A13 |
| — | AN29 | P | AN29 | eQADC A and B shared analog input | I | AE | V _{DDA_A0} | AN29 | AN29 | B14 |
| — | AN30 | P | AN30 | eQADC A and B shared analog input | I | AE | V _{DDA_B1} | AN30 | AN30 | C14 |
| — | AN31 | P | AN31 | eQADC A and B shared analog input | I | AE | V _{DDA_B1} | AN31 | AN31 | D14 |
| — | AN32 | P | AN32 | eQADC A and B shared analog input | I | AE | V _{DDA_B1} | AN32 | AN32 | A14 |
| — | AN33 | P | AN33 | eQADC A and B shared analog input | I | AE | V _{DDA_B0} | AN33 | AN33 | B15 |
| — | AN34 | P | AN34 | eQADC A and B shared analog input | I | AE | V _{DDA_B0} | AN34 | AN34 | C15 |
| — | AN35 | P | AN35 | eQADC A and B shared analog input | I | AE | V _{DDA_B0} | AN35 | AN35 | D15 |

Table 3-4. Signal Properties and Muxing Summary (continued)

| GPIO/PCR ¹ | Signal Name ² | P/A/G ³ | Function ⁴ | Function Summary | Direction | Pad Type ⁵ | Voltage ⁶ | State during RESET ⁷ | State after RESET ⁸ | Package Location (416) |
|-----------------------|--------------------------|--------------------|-----------------------|-----------------------------------|-----------|-----------------------|----------------------|---------------------------------|--------------------------------|------------------------|
| — | AN36 | P | AN36 | eQADC A and B shared analog input | I | AE | V _{DDA_B1} | AN36 | AN36 | A15 |
| — | AN37 | P | AN37 | eQADC A and B shared analog input | I | AE | V _{DDA_B0} | AN37 | AN37 | C16 |
| — | AN38 | P | AN38 | eQADC A and B shared analog input | I | AE | V _{DDA_B0} | AN38 | AN38 | C17 |
| — | AN39 | P | AN39 | eQADC A and B shared analog input | I | AE | V _{DDA_B0} | AN39 | AN39 | D16 |
| — | ANB0 | P | ANB0 | eQADC B analog input | I | AE/up-down | V _{DDA_B0} | ANB0 | ANB0 | C18 |
| — | ANB1 | P | ANB1 | eQADC B analog input | I | AE/up-down | V _{DDA_B0} | ANB1 | ANB1 | D17 |
| — | ANB2 | P | ANB2 | eQADC B analog input | I | AE/up-down | V _{DDA_B0} | ANB2 | ANB2 | D18 |
| — | ANB3 | P | ANB3 | eQADC B analog input | I | AE/up-down | V _{DDA_B0} | ANB3 | ANB3 | D19 |
| — | ANB4 | P | ANB4 | eQADC B analog input | I | AE/up-down | V _{DDA_B0} | ANB4 | ANB4 | C19 |
| — | ANB5 | P | ANB5 | eQADC B analog input | I | AE/up-down | V _{DDA_B0} | ANB5 | ANB5 | C20 |
| — | ANB6 | P | ANB6 | eQADC B analog input | I | AE/up-down | V _{DDA_B0} | ANB6 | ANB6 | B19 |
| — | ANB7 | P | ANB7 | eQADC B analog input | I | AE/up-down | V _{DDA_B0} | ANB7 | ANB7 | A20 |
| — | ANB8 | P | ANB8 | eQADC B analog input | I | AE | V _{DDA_B0} | ANB8 | ANB8 | B20 |
| — | ANB9 | P | ANB9 | eQADC B analog input | I | AE | V _{DDA_B0} | ANB9 | ANB9 | D20 |
| — | ANB10 | P | ANB10 | eQADC B analog input | I | AE | V _{DDA_B0} | ANB10 | ANB10 | B21 |
| — | ANB11 | P | ANB11 | eQADC B analog input | I | AE | V _{DDA_B0} | ANB11 | ANB11 | A21 |
| — | ANB12 | P | ANB12 | eQADC B analog input | I | AE | V _{DDA_B0} | ANB12 | ANB12 | C21 |
| — | ANB13 | P | ANB13 | eQADC B analog input | I | AE | V _{DDA_B0} | ANB13 | ANB13 | D21 |
| — | ANB14 | P | ANB14 | eQADC B analog input | I | AE | V _{DDA_B0} | ANB14 | ANB14 | A22 |
| — | ANB15 | P | ANB15 | eQADC B analog input | I | AE | V _{DDA_B0} | ANB15 | ANB15 | B22 |

Table 3-4. Signal Properties and Muxing Summary (continued)

| GPIO/PCR ¹ | Signal Name ² | P/A/G ³ | Function ⁴ | Function Summary | Direction | Pad Type ⁵ | Voltage ⁶ | State during RESET ⁷ | State after RESET ⁸ | Package Location (416) |
|-----------------------|--------------------------|--------------------|-----------------------|----------------------------------|-----------|-----------------------|----------------------|---------------------------------|--------------------------------|------------------------|
| — | ANB16 | P | ANB16 | eQADC B analog input | I | AE | V _{DDA_B0} | ANB16 | ANB16 | C22 |
| — | ANB17 | P | ANB17 | eQADC B analog input | I | AE | V _{DDA_B0} | ANB17 | ANB17 | A23 |
| — | ANB18 | P | ANB18 | eQADC B analog input | I | AE | V _{DDA_B0} | ANB18 | ANB18 | B23 |
| — | ANB19 | P | ANB19 | eQADC B analog input | I | AE | V _{DDA_B0} | ANB19 | ANB19 | C23 |
| — | ANB20 | P | ANB20 | eQADC B analog input | I | AE | V _{DDA_B0} | ANB20 | ANB20 | D22 |
| — | ANB21 | P | ANB21 | eQADC B analog input | I | AE | V _{DDA_B0} | ANB21 | ANB21 | A24 |
| — | ANB22 | P | ANB22 | eQADC B analog input | I | AE | V _{DDA_B0} | ANB22 | ANB22 | B24 |
| — | ANB23 | P | ANB23 | eQADC B analog input | I | AE | V _{DDA_B0} | ANB23 | ANB23 | A25 |
| — | VRH_A | P | VRH_A | ADC A Voltage reference high | I | VDDINT | V _{RH_A} | VRH_A | VRH_A | A12 |
| — | VRL_A | P | VRL_A | ADC A Voltage reference low | I | VSSINT | V _{RL_A} | VRL_A | VRL_A | A11 |
| — | VRH_B | P | VRH_B | ADC B Voltage reference high | I | VDDINT | V _{RH_B} | VRH_B | VRH_B | A19 |
| — | VRL_B | P | VRL_B | ADC B Voltage reference low | I | VSSINT | V _{RL_B} | VRL_B | VRL_B | A18 |
| — | REFBYPCB | P | REFBYPCB | ADC B Reference bypass capacitor | I | AE | V _{DDA_B0} | REFBYPCB | REFBYPCB | B18 |
| — | REFBYPCA | P | REFBYPCA | ADC A Reference bypass capacitor | I | AE | V _{DDA_A1} | REFBYPCA | REFBYPCA | B11 |
| — | VDDA_A0 | P | VDDA_A | Internal logic supply input | I | VDDE | V _{DDA_A0} | VDDA_A0 | VDDA_A0 | A9 |
| — | VDDA_A1 | P | VDDA_A | Internal logic supply input | I | VDDE | V _{DDA_A1} | VDDA_A1 | VDDA_A1 | B9 |
| — | REFBYPCA1 | P | REFBYPCA1 | ADC A Reference bypass capacitor | I | AE | V _{DDA_A1} | REFBYPCA1 | REFBYPCA1 | A10 |
| — | VSSA_A1 | P | VSSA_A | Ground | I | VSSE | V _{SSA_A1} | VSSA_A1 | VSSA_A1 | B10 |
| — | VDDA_B0 | P | VDDA_B | Internal logic supply input | I | VDDE | V _{DDA_B0} | VDDA_B0 | VDDA_B0 | A16 |
| — | VDDA_B1 | P | VDDA_B | Internal logic supply input | I | VDDE | V _{DDA_B1} | VDDA_B1 | VDDA_B1 | B16 |
| — | VSSA_B0 | P | VSSA_B | Ground | I | VSSE | V _{SSA_B0} | VSSA_B0 | VSSA_B0 | B17 |
| — | REFBYPCB1 | P | REFBYPCB1 | ADC B Reference bypass capacitor | I | AE | V _{DDA_B0} | REFBYPCB1 | REFBYPCB1 | A17 |

Table 3-4. Signal Properties and Muxing Summary (continued)

| GPIO/PCR ¹ | Signal Name ² | P/A/G ³ | Function ⁴ | Function Summary | Direction | Pad Type ⁵ | Voltage ⁶ | State during RESET ⁷ | State after RESET ⁸ | Package Location (416) |
|-----------------------|--------------------------|--------------------|-----------------------|---------------------------|-----------|-----------------------|----------------------|---|---|------------------------|
| FlexRay | | | | | | | | | | |
| 248 | FR_A_TX_ GPIO248 | P | FR_A_TX | FlexRay A transfer | O | FS | V _{DDE2} | —/Up (—/ for Rev.1 of the device) | —/Up (—/ for Rev.1 of the device) | AD4 |
| | | A1 | — | — | — | | | | | |
| | | A2 | — | — | — | | | | | |
| | | G | GPIO248 | GPIO | I/O | | | | | |
| 249 | FR_A_RX_ GPIO249 | P | FR_A_RX | FlexRay A receive | I | FS | V _{DDE2} | —/Up (—/ for Rev.1 of the device) | —/Up (—/ for Rev.1 of the device) | AE3 |
| | | A1 | — | — | — | | | | | |
| | | A2 | — | — | — | | | | | |
| | | G | GPIO249 | GPIO | I/O | | | | | |
| 250 | FR_A_TX_EN_ GPIO250 | P | FR_A_TX_EN | FlexRay A transfer enable | O | FS | V _{DDE2} | —/Up (—/ for Rev.1 of the device) | —/Up (—/ for Rev.1 of the device) | AF3 |
| | | A1 | — | — | — | | | | | |
| | | A2 | — | — | — | | | | | |
| | | G | GPIO250 | GPIO | I/O | | | | | |
| 251 | FR_B_TX_ GPIO251 | P | FR_B_TX | FlexRay B transfer | O | FS | V _{DDE2} | —/Up (—/ for Rev.1 of the device) | —/Up (—/ for Rev.1 of the device) | AD5 |
| | | A1 | — | — | — | | | | | |
| | | A2 | — | — | — | | | | | |
| | | G | GPIO251 | GPIO | I/O | | | | | |
| 252 | FR_B_RX_ GPIO252 | P | FR_B_RX | FlexRay B receive | I | FS | V _{DDE2} | —/Up (—/ for Rev.1 of the device) | —/Up (—/ for Rev.1 of the device) | AE4 |
| | | A1 | — | — | — | | | | | |
| | | A2 | — | — | — | | | | | |
| | | G | GPIO252 | GPIO | I/O | | | | | |
| 253 | FR_B_TX_EN_ GPIO253 | P | FR_B_TX_EN | FlexRay B transfer enable | O | FS | V _{DDE2} | —/Up (—/ for Rev.1 of the device) | —/Up (—/ for Rev.1 of the device) | AF4 |
| | | A1 | — | — | — | | | | | |
| | | A2 | — | — | — | | | | | |
| | | G | GPIO253 | GPIO | I/O | | | | | |

Table 3-4. Signal Properties and Muxing Summary (continued)

| GPIO/PCR ¹ | Signal Name ² | P/A/G ³ | Function ⁴ | Function Summary | Direction | Pad Type ⁵ | Voltage ⁶ | State during RESET ⁷ | State after RESET ⁸ | Package Location (416) |
|-----------------------|--------------------------|--------------------|-----------------------|-------------------------------|-----------|-----------------------|----------------------|---------------------------------|--------------------------------|------------------------|
| FlexCAN | | | | | | | | | | |
| 83 | CNTXA_TXDA_ GPIO83 | P | CNTXA | FlexCAN A transmit | O | MH | V _{DDEH4} | —/Up | —/Up | AF19 |
| | | A1 | TXDA | eSCI A transmit | O | | | | | |
| | | A2 | — | — | — | | | | | |
| | | G | GPIO83 | GPIO | I/O | | | | | |
| 84 | CNRXA_RXDA_ GPIO84 | P | CNRXA | FlexCAN A receive | I | MH | V _{DDEH4} | —/Up | —/Up | AE19 |
| | | A1 | RXDA | eSCI A receive | I | | | | | |
| | | A2 | — | — | — | | | | | |
| | | G | GPIO84 | GPIO | I/O | | | | | |
| 85 | CNTXB_PCSC3_ GPIO85 | P | CNTXB | FlexCAN B transmit | O | MH | V _{DDEH4} | —/Up | —/Up | AD19 |
| | | A1 | PCSC3 | DSPI C peripheral chip select | O | | | | | |
| | | A2 | — | — | — | | | | | |
| | | G | GPIO85 | GPIO | I/O | | | | | |
| 86 | CNRXB_PCSC4_ GPIO86 | P | CNRXB | FlexCAN B receive | I | MH | V _{DDEH4} | —/Up | —/Up | AC19 |
| | | A1 | PCSC4 | DSPI C peripheral chip select | O | | | | | |
| | | A2 | — | — | — | | | | | |
| | | G | GPIO86 | GPIO | I/O | | | | | |
| 87 | CNTXC_PCSD3_ GPIO87 | P | CNTXC | FlexCAN C transmit | O | MH | V _{DDEH4} | —/Up | —/Up | AF20 |
| | | A1 | PCSD3 | DSPI D peripheral chip select | O | | | | | |
| | | A2 | — | — | — | | | | | |
| | | G | GPIO87 | GPIO | I/O | | | | | |
| 88 | CNRXC_PCSD4_ GPIO88 | P | CNRXC | FlexCAN C receive | I | MH | V _{DDEH4} | —/Up | —/Up | AE20 |
| | | A1 | PCSD4 | DSPI D peripheral chip select | O | | | | | |
| | | A2 | — | — | — | | | | | |
| | | G | GPIO88 | GPIO | I/O | | | | | |

Table 3-4. Signal Properties and Muxing Summary (continued)

| GPIO/PCR ¹ | Signal Name ² | P/A/G ³ | Function ⁴ | Function Summary | Direction | Pad Type ⁵ | Voltage ⁶ | State during RESET ⁷ | State after RESET ⁸ | Package Location (416) |
|-----------------------|--------------------------|--------------------|-----------------------|-------------------------------|-----------|-----------------------|----------------------|---------------------------------|--------------------------------|------------------------|
| 246 | CNTXD_ GPIO246 | P | CNTXD | FlexCAN D transmit | O | MH | V _{DDEH4} | —/Up | —/Up | AD20 |
| | | A1 | — | — | — | | | | | |
| | | A2 | — | — | — | | | | | |
| | | G | GPIO246 | GPIO | I/O | | | | | |
| 247 | CNRXD_ GPIO247 | P | CNRXD | FlexCAN D receive | I | MH | V _{DDEH4} | —/Up | —/Up | AC20 |
| | | A1 | — | — | — | | | | | |
| | | A2 | — | — | — | | | | | |
| | | G | GPIO247 | GPIO | I/O | | | | | |
| eSCI | | | | | | | | | | |
| 89 | TXDA_ GPIO89 | P | TXDA | eSCI A transmit | O | MH | V _{DDEH1} | —/Up | —/Up | M2 |
| | | A1 | — | — | — | | | | | |
| | | A2 | — | — | — | | | | | |
| | | G | GPIO89 | GPIO | I/O | | | | | |
| 90 | RXDA_ GPIO90 | P | RXDA | eSCI A receive | I | MH | V _{DDEH1} | —/Up | —/Up | M3 |
| | | A1 | — | — | — | | | | | |
| | | A2 | — | — | — | | | | | |
| | | G | GPIO90 | GPIO | I | | | | | |
| 91 | TXDB_PCSD1_ GPIO91 | P | TXDB | eSCI B transmit | O | MH | V _{DDEH1} | —/Up | —/Up | P1 |
| | | A1 | PCSD1 | DSPI D peripheral chip select | O | | | | | |
| | | A2 | — | — | — | | | | | |
| | | G | GPIO91 | GPIO | I/O | | | | | |
| 92 | RXDB_PCSD5_ GPIO92 | P | RXDB | eSCI B receive | I | MH | V _{DDEH1} | —/Up | —/Up | N1 |
| | | A1 | PCSD5 | DSPI D peripheral chip select | O | | | | | |
| | | A2 | — | — | — | | | | | |
| | | G | GPIO92 | GPIO | I/O | | | | | |

Table 3-4. Signal Properties and Muxing Summary (continued)

| GPIO/PCR ¹ | Signal Name ² | P/A/G ³ | Function ⁴ | Function Summary | Direction | Pad Type ⁵ | Voltage ⁶ | State during RESET ⁷ | State after RESET ⁸ | Package Location (416) |
|-----------------------|--------------------------|--------------------|-----------------------|-------------------------------|-----------|-----------------------|----------------------|---------------------------------|--------------------------------|------------------------|
| 244 | TXDC_ETRIG0_ GPIO244 | P | TXDC | eSCI C transmit | O | MH | V _{DDEH4} | —/Up | —/Up | AF23 |
| | | A1 | ETRIG0 | eQADC trigger input | I | | | | | |
| | | A2 | — | — | — | | | | | |
| | | G | GPIO244 | GPIO | I/O | | | | | |
| 245 | RXDC_ GPIO245 | P | RXDC | eSCI C receive | I | MH | V _{DDEH5} | —/Up | —/Up | AD22 |
| | | A1 | — | — | — | | | | | |
| | | A2 | — | — | — | | | | | |
| | | G | GPIO245 | GPIO | I/O | | | | | |
| DSPI | | | | | | | | | | |
| 93 | SCKA_PCSC1_ GPIO93 | P | SCKA | DSPI A clock | I/O | MH | V _{DDEH3} | —/Up | —/Up | AD8 |
| | | A1 | PCSC1 | DSPI C peripheral chip select | O | | | | | |
| | | A2 | — | — | — | | | | | |
| | | G | GPIO93 | GPIO | I/O | | | | | |
| 94 | SINA_PCSC2_ GPIO94 | P | SINA | DSPI A data input | I | MH | V _{DDEH3} | —/Up | —/Up | AF7 |
| | | A1 | PCSC2 | DSPI C peripheral chip select | O | | | | | |
| | | A2 | — | — | — | | | | | |
| | | G | GPIO94 | GPIO | I/O | | | | | |
| 95 | SOUTA_PCSC5_ GPIO95 | P | SOUTA | DSPI A data output | O | MH | V _{DDEH3} | —/Up | —/Up | AD7 |
| | | A1 | PCSC5 | DSPI C peripheral chip select | O | | | | | |
| | | A2 | — | — | — | | | | | |
| | | G | GPIO95 | GPIO | I/O | | | | | |
| 96 | PCSA0_PCSD2_ GPIO96 | P | PCSA0 | DSPI A peripheral chip select | I/O | MH | V _{DDEH3} | —/Up | —/Up | AE6 |
| | | A1 | PCSD2 | DSPI D peripheral chip select | O | | | | | |
| | | A2 | — | — | — | | | | | |
| | | G | GPIO96 | GPIO | I/O | | | | | |

Table 3-4. Signal Properties and Muxing Summary (continued)

| GPIO/PCR ¹ | Signal Name ² | P/A/G ³ | Function ⁴ | Function Summary | Direction | Pad Type ⁵ | Voltage ⁶ | State during RESET ⁷ | State after RESET ⁸ | Package Location (416) |
|-----------------------|--------------------------|--------------------|-----------------------|-------------------------------|-----------|-----------------------|----------------------|---------------------------------|--------------------------------|------------------------|
| 97 | PCSA1_ GPIO97 | P | PCSA1 | DSPI A peripheral chip select | O | MH | V _{DDEH3} | —/Up | —/Up | AC6 |
| | | A1 | — | — | — | | | | | |
| | | A2 | — | — | — | | | | | |
| | | G | GPIO97 | GPIO | I/O | | | | | |
| 98 | PCSA2_ GPIO98 | P | PCSA2 | DSPI A peripheral chip select | O | MH | V _{DDEH3} | —/Up | —/Up | AC7 |
| | | A1 | — | — | — | | | | | |
| | | A2 | — | — | — | | | | | |
| | | G | GPIO98 | GPIO | I/O | | | | | |
| 99 | PCSA3_ GPIO99 | P | PCSA3 | DSPI A peripheral chip select | O | MH | V _{DDEH3} | —/Up | —/Up | AE7 |
| | | A1 | — | — | — | | | | | |
| | | A2 | — | — | — | | | | | |
| | | G | GPIO99 | GPIO | I/O | | | | | |
| 100 | PCSA4_ GPIO100 | P | PCSA4 | DSPI A peripheral chip select | O | MH | V _{DDEH3} | —/Up | —/Up | AE5 |
| | | A1 | — | — | — | | | | | |
| | | A2 | — | — | — | | | | | |
| | | G | GPIO100 | GPIO | I/O | | | | | |
| 101 | PCSA5_ETRIG1_ GPIO101 | P | PCSA5 | DSPI A peripheral chip select | O | MH | V _{DDEH3} | —/Up | —/Up | AD6 |
| | | A1 | ETRIG1 | eQADC trigger input | I | | | | | |
| | | A2 | — | — | — | | | | | |
| | | G | GPIO101 | GPIO | I/O | | | | | |
| 102 | SCKB_ GPIO102 | P | SCKB | DSPI B clock | I/O | MH | V _{DDEH3} | —/Up | —/Up | AE8 |
| | | A1 | — | — | — | | | | | |
| | | A2 | — | — | — | | | | | |
| | | G | GPIO102 | GPIO | I/O | | | | | |

Table 3-4. Signal Properties and Muxing Summary (continued)

| GPIO/PCR ¹ | Signal Name ² | P/A/G ³ | Function ⁴ | Function Summary | Direction | Pad Type ⁵ | Voltage ⁶ | State during RESET ⁷ | State after RESET ⁸ | Package Location (416) |
|-----------------------|--------------------------|--------------------|-----------------------|-------------------------------|-----------|-----------------------|----------------------|---------------------------------|--------------------------------|------------------------|
| 103 | SINB_ GPIO103 | P | SINB | DSPI B data input | I | MH | V _{DDEH3} | —/Up | —/Up | AE9 |
| | | A1 | — | — | — | | | | | |
| | | A2 | — | — | — | | | | | |
| | | G | GPIO103 | GPIO | I/O | | | | | |
| 104 | SOUTB_ GPIO104 | P | SOUTB | DSPI B data output | O | MH | V _{DDEH3} | —/Up | —/Up | AF9 |
| | | A1 | — | — | — | | | | | |
| | | A2 | — | — | — | | | | | |
| | | G | GPIO104 | GPIO | I/O | | | | | |
| 105 | PCSB0_PCSD2_ GPIO105 | P | PCSB0 | DSPI B peripheral chip select | I/O | MH | V _{DDEH3} | —/Up | —/Up | AD9 |
| | | A1 | PCSD2 | DSPI D peripheral chip select | O | | | | | |
| | | A2 | — | — | — | | | | | |
| | | G | GPIO105 | GPIO | I/O | | | | | |
| 106 | PCSB1_PCSD0_ GPIO106 | P | PCSB1 | DSPI B peripheral chip select | O | MH | V _{DDEH3} | —/Up | —/Up | AC9 |
| | | A1 | PCSD0 | DSPI D peripheral chip select | I/O | | | | | |
| | | A2 | — | — | — | | | | | |
| | | G | GPIO106 | GPIO | I/O | | | | | |
| 107 | PCSB2_SOUTC_ GPIO107 | P | PCSB2 | DSPI B peripheral chip select | O | MH | V _{DDEH3} | —/Up | —/Up | AF8 |
| | | A1 | SOUTC | DSPI C data output | O | | | | | |
| | | A2 | — | — | — | | | | | |
| | | G | GPIO107 | GPIO | I/O | | | | | |
| 108 | PCSB3_SINC_ GPIO108 | P | PCSB3 | DSPI B peripheral chip select | O | MH | V _{DDEH3} | —/Up | —/Up | AD10 |
| | | A1 | SINC | DSPI C data input | I | | | | | |
| | | A2 | — | — | — | | | | | |
| | | G | GPIO108 | GPIO | I/O | | | | | |

Table 3-4. Signal Properties and Muxing Summary (continued)

| GPIO/PCR ¹ | Signal Name ² | P/A/G ³ | Function ⁴ | Function Summary | Direction | Pad Type ⁵ | Voltage ⁶ | State during RESET ⁷ | State after RESET ⁸ | Package Location (416) |
|-----------------------|--------------------------------|--------------------|-----------------------|---|-----------|-----------------------|----------------------|---------------------------------|--------------------------------|------------------------|
| 109 | PCSB4_SCKC_ GPIO109 | P | PCSB4 | DSPI B peripheral chip select | O | MH | V _{DDEH3} | —/Up | —/Up | AC8 |
| | | A1 | SCKC | DSPI C clock | I/O | | | | | |
| | | A2 | — | — | — | | | | | |
| | | G | GPIO109 | GPIO | I/O | | | | | |
| 110 | PCSB5_PCSC0_ GPIO110 | P | PCSB5 | DSPI B peripheral chip select | O | MH | V _{DDEH3} | —/Up | —/Up | AF6 |
| | | A1 | PCSC0 | DSPI C peripheral chip select | I/O | | | | | |
| | | A2 | — | — | — | | | | | |
| | | G | GPIO110 | GPIO | I/O | | | | | |
| 235 | SCKC_SCK_C_LVDSP_ GPIO235 | P | SCKC | DSPI C clock | I/O | MH+ LVDS | V _{DDEH4} | —/Up | —/Up | AD21 |
| | | A1 | SCK_C_LVDSP | LVDS+ downstream signal positive output clock | O | | | | | |
| | | A2 | — | — | — | | | | | |
| | | G | GPIO235 | GPIO | I/O | | | | | |
| 236 | SINC_SCK_C_LVDSM_ GPIO236 | P | SINC | DSPI C data input | I | MH+ LVDS | V _{DDEH4} | —/Up | —/Up | AE22 |
| | | A1 | SCK_C_LVDSM | LVDS– downstream signal negative output clock | O | | | | | |
| | | A2 | — | — | — | | | | | |
| | | G | GPIO236 | GPIO | I/O | | | | | |
| 237 | SOUTC_SOUT_C_LVDSP_ GPIO237 | P | SOUTC | DSPI C data output | O | MH+ LVDS | V _{DDEH4} | —/Up | —/Up | AF21 |
| | | A1 | SOUT_C_LVDSP | LVDS+ downstream signal positive output data | O | | | | | |
| | | A2 | — | — | — | | | | | |
| | | G | GPIO237 | GPIO | I/O | | | | | |

Table 3-4. Signal Properties and Muxing Summary (continued)

| GPIO/PCR ¹ | Signal Name ² | P/A/G ³ | Function ⁴ | Function Summary | Direction | Pad Type ⁵ | Voltage ⁶ | State during RESET ⁷ | State after RESET ⁸ | Package Location (416) |
|-----------------------|----------------------------|--------------------|-----------------------|--|-----------|-----------------------|----------------------|---------------------------------|--------------------------------|------------------------|
| 238 | PCSC0_SOUT_C_LVDSM_GPIO238 | P | PCSC0 | DSPI C peripheral chip select | I/O | MH+LVDS | V _{DDEH4} | —/Up | —/Up | AE21 |
| | | A1 | SOUT_C_LVDSM | LVDS– downstream signal negative output data | O | | | | | |
| | | A2 | — | — | — | | | | | |
| | | G | GPIO238 | GPIO | I/O | | | | | |
| 239 | PCSC1_GPIO239 | P | PCSC1 | DSPI C peripheral chip select | O | MH | V _{DDEH4} | —/Up | —/Up | AC22 |
| | | A1 | — | — | — | | | | | |
| | | A2 | — | — | — | | | | | |
| | | G | GPIO239 | GPIO | I/O | | | | | |
| 240 | PCSC2_GPIO240 | P | PCSC2 | DSPI C peripheral chip select | O | MH | V _{DDEH5} | —/Up | —/Up | AE23 |
| | | A1 | — | — | — | | | | | |
| | | A2 | — | — | — | | | | | |
| | | G | GPIO240 | GPIO | I/O | | | | | |
| 241 | PCSC3_GPIO241 | P | PCSC3 | DSPI C peripheral chip select | O | MH | V _{DDEH5} | —/Up | —/Up | AD23 |
| | | A1 | — | — | — | | | | | |
| | | A2 | — | — | — | | | | | |
| | | G | GPIO241 | GPIO | I/O | | | | | |
| 242 | PCSC4_GPIO242 | P | PCSC4 | DSPI C peripheral chip select | O | MH | V _{DDEH5} | —/Up | —/Up | AF24 |
| | | A1 | — | — | — | | | | | |
| | | A2 | — | — | — | | | | | |
| | | G | GPIO242 | GPIO | I/O | | | | | |
| 243 | PCSC5_GPIO243 | P | PCSC5 | DSPI C peripheral chip select | O | MH | V _{DDEH5} | —/Up | —/Up | AE24 |
| | | A1 | — | — | — | | | | | |
| | | A2 | — | — | — | | | | | |
| | | G | GPIO243 | GPIO | I/O | | | | | |

Table 3-4. Signal Properties and Muxing Summary (continued)

| GPIO/PCR ¹ | Signal Name ² | P/A/G ³ | Function ⁴ | Function Summary | Direction | Pad Type ⁵ | Voltage ⁶ | State during RESET ⁷ | State after RESET ⁸ | Package Location (416) |
|-------------------------|--------------------------|--------------------|-----------------------|--|-----------|-----------------------|----------------------|---------------------------------|--|------------------------|
| Reset and Clocks | | | | | | | | | | |
| — | RESET | P | RESET | External reset input | I | MH | V _{DDEH1} | RESET/Up | RESET/Up | R2 |
| 230 | RSTOUT | P | RSTOUT | External reset output | O | MH | V _{DDEH1} | RSTOUT/Low | RSTOUT/High | A3 |
| 212 | BOOTCFG1_IRQ3_GPIO212 | P | BOOTCFG1 | Boot configuration | I | MH | V _{DDEH1} | BOOTCFG/Down | Input/Down | N2 |
| | | A1 | IRQ3 | External interrupt request | I | | | | | |
| | | A2 | — | — | — | | | | | |
| | | G | GPIO212 | GPIO | I/O | | | | | |
| 213 | WKPCFG_NMI_GPIO213 | P | WKPCFG | Weak pull configuration input | I | MH | V _{DDEH1} | WKPCFG/Up | Input/Up | N3 |
| | | A1 | NMI | Critical interrupt to core ¹¹ | I | | | | | |
| | | A2 | — | — | — | | | | | |
| | | G | GPIO213 | GPIO | I | | | | | |
| 208 | PLLCFG0_IRQ4_GPIO208 | P | PLLCFG0 | FMPLL mode configuration input | I | MH | V _{DDEH1} | PLLCFG/Up | Input/Up | R3 |
| | | A1 | IRQ4 | External interrupt request | I | | | | | |
| | | A2 | — | — | — | | | | | |
| | | G | GPIO208 | GPIO | I/O | | | | | |
| 209 | PLLCFG1_IRQ5_GPIO209 | P | PLLCFG1 | FMPLL mode configuration input | I | MH | V _{DDEH1} | PLLCFG/Up | Input/Up (for Rev2 of the device: —/Up) | P2 |
| | | A1 | IRQ5 | External interrupt request | I | | | | | |
| | | A2 | SOUTD | DSPI D data output | O | | | | | |
| | | G | GPIO209 | GPIO | I/O | | | | | |
| — | PLLCFG2 | P | PLLCFG2 | FMPLL mode configuration input | I | MH | V _{DDEH1} | PLLCFG/Down | PLLCFG/Down | P3 |
| — | XTAL | P | XTAL | Crystal oscillator output | O | AE | V _{DD33} | XTAL | XTAL | AC26 |
| — | EXTAL | P | EXTAL | Crystal oscillator input | I | AE | V _{DD33} | EXTAL | EXTAL | AB26 |

Table 3-4. Signal Properties and Muxing Summary (continued)

| GPIO/PCR ¹ | Signal Name ² | P/A/G ³ | Function ⁴ | Function Summary | Direction | Pad Type ⁵ | Voltage ⁶ | State during RESET ⁷ | State after RESET ⁸ | Package Location (416) |
|--|--|--------------------|-----------------------|--|-----------|-----------------------|----------------------|---------------------------------|--------------------------------|------------------------|
| 214 | ENGCLK | P | ENGCLK | EBI engineering clock output Note: EXTCLK (External clock input) selected through SIU register) | O | F | V _{DDE2} | ENGCLK/Enabled | ENGCLK/Enabled | AD1 |
| JTAG and Nexus (see footnote¹² about resets) | | | | | | | | | | |
| — | EVTI | ₁₃ | EVTI | Nexus event in | I | F | V _{DDE2} | —/Up | EVTI/Up | T4 |
| 227 | EVT _O (the BAM uses this pin to select if auto baud rate is on or off) | ₁₃ | EVTO | Nexus event out | O | F | V _{DDE2} | ABS/Up | EVTO/Hi | U1 |
| 219 | MCKO | ₁₃ | MCKO | Nexus message clock out | O | F | V _{DDE2} | O/Low | Disabled ¹⁴ | T2 |
| 220 | MDO0_GPIO220 (GPIO function on this pin is only available on Rev.2 of the device) | ₁₃ | MDO0 ¹⁵ | Nexus message data out | O | F | V _{DDE2} | O/Low | MDO0/Low | U3 |
| | | A1 | — | — | — | | | | | |
| | | A2 | — | — | — | | | | | |
| | | G | GPIO220 | GPIO | I/O | | | | | |
| 221 | MDO1_GPIO221 (GPIO function on this pin is only available on Rev.2 of the device) | ₁₃ | MDO1 ¹⁵ | Nexus message data out | O | F | V _{DDE2} | O/Low | —/Down | U4 |
| | | A1 | — | — | — | | | | | |
| | | A2 | — | — | — | | | | | |
| | | G | GPIO221 | GPIO | I/O | | | | | |
| 222 | MDO2_GPIO222 (GPIO function on this pin is only available on Rev.2 of the device) | ₁₃ | MDO2 ¹⁵ | Nexus message data out | O | F | V _{DDE2} | O/Low | —/Down | V1 |
| | | A1 | — | — | — | | | | | |
| | | A2 | — | — | — | | | | | |
| | | G | GPIO222 | GPIO | I/O | | | | | |
| 223 | MDO3_GPIO223 (GPIO function on this pin is only available on Rev.2 of the device) | ₁₃ | MDO3 ¹⁵ | Nexus message data out | O | F | V _{DDE2} | O/Low | —/Down | V2 |
| | | A1 | — | — | — | | | | | |
| | | A2 | — | — | — | | | | | |
| | | G | GPIO223 | GPIO | I/O | | | | | |

Table 3-4. Signal Properties and Muxing Summary (continued)

| GPIO/PCR ¹ | Signal Name ² | P/A/G ³ | Function ⁴ | Function Summary | Direction | Pad Type ⁵ | Voltage ⁶ | State during RESET ⁷ | State after RESET ⁸ | Package Location (416) |
|-----------------------|---|--------------------|-----------------------|------------------------|-----------|-----------------------|----------------------|---------------------------------|--------------------------------|------------------------|
| 75 | MDO4_GPIO75 (GPIO function on this pin is only available on Rev.2 of the device) | _13 | MDO4 ¹⁵ | Nexus message data out | O | F | V _{DDE2} | O/Low | —/Down | V3 |
| | | A1 | — | — | — | | | | | |
| | | A2 | — | — | — | | | | | |
| | | G | GPIO75 | GPIO | I/O | | | | | |
| 76 | MDO5_GPIO76 (GPIO function on this pin is only available on Rev.2 of the device) | _13 | MDO5 ¹⁵ | Nexus message data out | O | F | V _{DDE2} | O/Low | —/Down | V4 |
| | | A1 | — | — | — | | | | | |
| | | A2 | — | — | — | | | | | |
| | | G | GPIO76 | GPIO | I/O | | | | | |
| 77 | MDO6_GPIO77 (GPIO function on this pin is only available on Rev.2 of the device) | _13 | MDO6 ¹⁵ | Nexus message data out | O | F | V _{DDE2} | O/Low | —/Down | W1 |
| | | A1 | — | — | — | | | | | |
| | | A2 | — | — | — | | | | | |
| | | G | GPIO77 | GPIO | I/O | | | | | |
| 78 | MDO7_GPIO78 (GPIO function on this pin is only available on Rev.2 of the device) | _13 | MDO7 ¹⁵ | Nexus message data out | O | F | V _{DDE2} | O/Low | —/Down | W2 |
| | | A1 | — | — | — | | | | | |
| | | A2 | — | — | — | | | | | |
| | | G | GPIO78 | GPIO | I/O | | | | | |
| 79 | MDO8_GPIO79 (GPIO function on this pin is only available on Rev.2 of the device) | _13 | MDO8 ¹⁵ | Nexus message data out | O | F | V _{DDE2} | O/Low | —/Down | W3 |
| | | A1 | — | — | — | | | | | |
| | | A2 | — | — | — | | | | | |
| | | G | GPIO79 | GPIO | I/O | | | | | |
| 80 | MDO9_GPIO80 (GPIO function on this pin is only available on Rev.2 of the device) | _13 | MDO9 ¹⁵ | Nexus message data out | O | F | V _{DDE2} | O/Low | —/Down | Y1 |
| | | A1 | — | — | — | | | | | |
| | | A2 | — | — | — | | | | | |
| | | G | GPIO80 | GPIO | I/O | | | | | |

Table 3-4. Signal Properties and Muxing Summary (continued)

| GPIO/PCR ¹ | Signal Name ² | P/A/G ³ | Function ⁴ | Function Summary | Direction | Pad Type ⁵ | Voltage ⁶ | State during RESET ⁷ | State after RESET ⁸ | Package Location (416) |
|-----------------------|--|--------------------|-----------------------|-----------------------------|-----------|-----------------------|----------------------|---------------------------------|--------------------------------|------------------------|
| 81 | MDO10_GPIO81 (GPIO function on this pin is only available on Rev.2 of the device) | _13 | MDO10 ¹⁵ | Nexus message data out | O | F | V _{DDE2} | O/Low | —/Down | Y2 |
| | | A1 | — | — | — | | | | | |
| | | A2 | — | — | — | | | | | |
| | | G | GPIO81 | GPIO | I/O | | | | | |
| 82 | MDO11_GPIO82 (GPIO function on this pin is only available on Rev.2 of the device) | _13 | MDO11 ¹⁵ | Nexus message data out | O | F | V _{DDE2} | O/Low | —/Down | Y3 |
| | | A1 | — | — | — | | | | | |
| | | A2 | — | — | — | | | | | |
| | | G | GPIO82 | GPIO | I/O | | | | | |
| 231 | MDO12_GPIO231 | _13 | MDO12 ¹⁵ | Nexus message data out | O | F | V _{DDE2} | O/Low | —/Down | AA1 |
| | | A1 | — | — | — | | | | | |
| | | A2 | — | — | — | | | | | |
| | | G | GPIO231 | GPIO | I/O | | | | | |
| 232 | MDO13_GPIO232 | _13 | MDO13 ¹⁵ | Nexus message data out | O | F | V _{DDE2} | O/Low | —/Down | AA2 |
| | | A1 | — | — | — | | | | | |
| | | A2 | — | — | — | | | | | |
| | | G | GPIO232 | GPIO | I/O | | | | | |
| 233 | MDO14_GPIO233 | _13 | MDO14 ¹⁵ | Nexus message data out | O | F | V _{DDE2} | O/Low | —/Down | AA3 |
| | | A1 | — | — | — | | | | | |
| | | A2 | — | — | — | | | | | |
| | | G | GPIO233 | GPIO | I/O | | | | | |
| 234 | MDO15_GPIO234 | _13 | MDO15 ¹⁵ | Nexus message data out | O | F | V _{DDE2} | O/Low | —/Down | Y4 |
| | | A1 | — | — | — | | | | | |
| | | A2 | — | — | — | | | | | |
| | | G | GPIO234 | GPIO | I/O | | | | | |
| 224 | MSEO0 | _13 | MSEO0 ¹⁵ | Nexus message start/end out | O | F | V _{DDE2} | O/Low | MSEO/HI | U2 |

Table 3-4. Signal Properties and Muxing Summary (continued)

| GPIO/PCR ¹ | Signal Name ² | P/A/G ³ | Function ⁴ | Function Summary | Direction | Pad Type ⁵ | Voltage ⁶ | State during RESET ⁷ | State after RESET ⁸ | Package Location (416) |
|-----------------------|--------------------------|--------------------|-----------------------|---|-----------|-----------------------|----------------------|---------------------------------|--------------------------------|------------------------|
| 225 | MSEO1 | _13 | MSEO1 ¹⁵ | Nexus message start/end out | O | F | V _{DDE2} | O/Low | MSEO/HI | T3 |
| 226 | RDY | _13 | RDY | Nexus ready output | O | F | V _{DDE2} | O/Low | RDY/HI | R4 |
| — | TCK | _13 | TCK | JTAG test clock input | I | F | V _{DDE2} | TCK/Down | TCK/Down | AB2 |
| — | TDI | _13 | TDI | JTAG test data input | I | F | V _{DDE2} | TDI/Up | TDI/Up | AC2 |
| 228 | TDO | _13 | TDO | JTAG test data output | O | F | V _{DDE2} | TDO/Up | TDO/Up | AB1 |
| — | TMS | _13 | TMS | JTAG test mode select input | I | F | V _{DDE2} | TMS/Up | TMS/Up | AB3 |
| — | JCOMP | _13 | JCOMP | JTAG TAP controller enable | I | F | V _{DDE2} | JCOMP/Down | JCOMP/Down | R1 |
| — | TEST | — | TEST | Test mode select (not for customer use) | I | F | V _{DDEH1} | TEST/Down | TEST/Down | B4 |
| — | VDDSYN | — | VDDSYN | Clock synthesizer power input | I | VDDE | V _{DDSYN} | VDDSYN | VDDSYN | AD26 |
| — | VSSSYN | — | VSSSYN | Clock synthesizer ground input | I | VSSE | V _{DDSYN} | VSSSYN | VSSSYN | AA26 |
| — | VSTBY | — | VSTBY | SRAM standby power input | I | VHV | V _{DDEH1} | VSTBY | VSTBY | M4 |
| — | REGSEL | — | REGSEL | Selects regulator mode (Linear/Switch mode) | I | AE | V _{DDREG} | REGSEL | REGSEL | W23 |
| — | REGCTL | — | REGCTL | Regulator controller output to base/gate of power transistor | O | AE | V _{DDREG} | REGCTL | REGCTL | Y26 |
| — | VSSFL | — | VSSFL | Tie to V _{SS} | I | VSS | V _{DDREG} | VSSFL | VSSFL | AB25 |
| — | VDDREG | — | VDDREG | Source voltage for on-chip regulators and Low voltage detect circuits | I | VDDINT | V _{DDREG} | VDDREG | VDDREG | AA25 |

¹ The GPIO number is the same as the corresponding pad configuration register (SIU_PCR n) number in pins that have GPIO functionality. For pins that do not have GPIO functionality, this number is the PCR number.

² The primary signal name is used as the pin label on the BGA map for identification purposes. However, the primary signal function is not available on all devices and is indicated by a dash in the following table columns: Signal Functions, P/F/G, and I/O Type.

³ P/A/G stands for Primary/Alternate/GPIO. This column indicates which function on a pin is Primary, Alternate 1, Alternate 2, (Alternate n) and GPIO.

⁴ Each line in the Function column corresponds to a separate signal function on the pin. For all device I/O pins, the primary, alternate, or GPIO signal functions are designated in the PA field of the SIU_PCR n registers except where explicitly noted.

- ⁵ MH = High voltage, medium speed
 F = Fast speed
 FS = Fast speed with slew
 AE = Analog with ESD protection circuitry (up/down = pull up and pull down circuits included in the pad)
 VHV = Very high voltage
- ⁶ VDDE (fast I/O) and VDDEH (slow I/O) power supply inputs are grouped into segments. Each segment of VDDEH pins can connect to a separate 3.3–5.0 V (+5%/–10%) power supply input. Each segment of VDDE pins can connect to a separate 1.8–3.3 V ($\pm 10\%$) power supply.
- ⁷ The Status During Reset pin is sampled after the internal POR is negated. Prior to exiting POR, the signal has a high impedance. The terminology used in this column is: O – output, I – input, Up – weak pull up enabled, Down – weak pulldown enabled, Low – output driven low, High – output driven high, ABS — Auto Baud Select (during Reset or until JCOMP assertion). A dash on the left side of the slash denotes that both the input and output buffers for the pin are off. A dash on the right side of the slash denotes that there is no weak pull up/down enabled on the pin. The signal name to the left or right of the slash indicates the pin is enabled.
- ⁸ The Function After Reset of a GPI function is general purpose input. A dash on the left side of the slash denotes that both the input and output buffers for the pin are off. A dash on the right side of the slash denotes that there is no weak pull up/down enabled on the pin.
- ⁹ This signal name includes eTPU_C functionality that this device does not have. This is for forward compatibility with devices that have an eTPU_C.
- ¹⁰ During and just after POR negates, internal pull resistors can be enabled, resulting in as much as 4 mA of current draw. The pull resistors are disabled when the system clock propagates through the device.
- ¹¹ NMI does not have a PCR PA configuration; it is enabled when NMI is enabled through the SIU_IREEER and SIU_IFEER registers.
- ¹² Nexus reset is different than system reset; MDO 1-11 are enabled when trace (RPM or FPM) is enabled, and MDO 12-15 when FPM trace is enabled. MSEO and MCKO are also dependent on trace (RPM or FPM) being enabled.
- ¹³ The Nexus pins don't have a "primary" function as they are not configured by the SIU. The pins are selected by asserting JCOMP and configuring the NPC. SIU values have no effect on the function of these pins once enabled.
- ¹⁴ MCKO is disabled from reset; it can be enabled from the tool (controlled by Nexus NPC_PCR register).

Refer to the *PXR40 Microcontroller Data Sheet* for ball-map figures.



3.3 Detailed Signal Description

This section provides detailed descriptions of the signal functions available for the device.

3.3.1 eTPU Signals

Table 3-5. eTPU Signals

| Signal Name | Description |
|---|--|
| TCRCLKA_ $\overline{\text{IRQ}}7$ _GPIO113 | TCRCLKA_ $\overline{\text{IRQ}}[7]$ _GPIO[113] is the TCR clock input for the eTPU A module. The first alternate function is an external interrupt request input for the SIU module. |
| ETPUA[0:11]_ETPUA[12:23]_GPIO[114:125] | ETPUA[0:11]_ETPUA[12:23]_GPIO[114:125] is an input/output channel pin for the eTPU A module. ETPUA[n] is the primary function and is an input/output channel for the eTPU A module. The alternate function, ETPUA[m], is an output channel for the eTPU A module. When configured as ETPUA[m], the pin functions as output only. |
| ETPUA12_PCSB1_GPIO126 | Input/output channel pin for the eTPU A module. The first alternate function is a peripheral chip select for the DSPI B module. |
| ETPUA13_PCSB3_GPIO127 | |
| ETPUA14_PCSB4_GPIO128 | |
| ETPUA15_PCSB5_GPIO129 | |
| ETPUA16_PCSD1_GPIO130 | Input/output channel pin for the eTPU A module. The first alternate function is a peripheral chip select for the DSPI D module. |
| ETPUA17_PCSD2_GPIO131 | |
| ETPUA18_PCSD3_GPIO132 | |
| ETPUA19_PCSD4_GPIO133 | |
| ETPUA20_ $\overline{\text{IRQ}}8$ _GPIO134 | Input/output channel pin for the eTPU A module. The first alternate function is an external interrupt request input for the SIU module. |
| ETPUA21_ $\overline{\text{IRQ}}9$ _GPIO135 | |
| ETPUA22_ $\overline{\text{IRQ}}10$ _GPIO136 | |
| ETPUA23_ $\overline{\text{IRQ}}11$ _GPIO137 | |
| ETPUA24_ $\overline{\text{IRQ}}12$ _GPIO138 | |
| ETPUA25_ $\overline{\text{IRQ}}13$ _GPIO139 | |
| ETPUA26_ $\overline{\text{IRQ}}14$ _GPIO140 | |
| ETPUA27_ $\overline{\text{IRQ}}15$ _GPIO141 | |
| ETPUA28_PCSC1_GPIO142 | Input/output channel pin for the eTPU A module. The first alternate function is a peripheral chip select for the DSPI C module. |
| ETPUA29_PCSC2_GPIO143 | |
| ETPUA30_PCSC3_GPIO144 | |
| ETPUA31_PCSC4_GPIO145 | |
| TCRCLKB_ $\overline{\text{IRQ}}6$ _GPIO146 | TCRCLKB_ $\overline{\text{IRQ}}[6]$ _GPIO[146] is the TCR B clock input for the eTPU module. The alternate function is an external interrupt request input for the SIU module. |
| ETPUB[0:15]_ETPUB[16:31]_GPIO[147:162] | ETPUB[0:15]_ETPUB[16:31]_GPIO[147:162] are 16 input/output channel pins for the eTPU B module. The alternate functions are output channels for the eTPU B module; that is, when configured as ETPUB[16:31], the pins function as outputs only. |

Table 3-5. eTPU Signals (continued)

| Signal Name | Description |
|--------------------------------------|--|
| ETPUB[16:19]_PCSA[1:4]_GPIO[163:166] | ETPUB[16:19]_PCSA[1:4]_GPIO[163:166] are input/output channel pins for the eTPU B module. The alternate functions are peripheral chip select signals for DSPI A. |
| ETPUB[20:31]_GPIO[167:178] | ETPUB[20:31]_GPIO[167:178] are input/output channel pins for the eTPU B module. |

3.3.2 IRQ and GPIO Signals

Table 3-6. IRQ and GPIO Signals ¹

| Signal Name | Description |
|--|--|
| TCRCLKC_GPIO440 | This pin does not have a primary function assigned to it. The primary function is reserved for eTPU_C for compatibility with future devices. |
| ETPUC0_GPIO441 | This pin does not have a primary function assigned to it. The primary function is reserved for eTPU_C for compatibility with future devices. |
| ETPUC1_GPIO442 | This pin does not have a primary function assigned to it. The primary function is reserved for eTPU_C for compatibility with future devices. |
| ETPUC2_GPIO443 | This pin does not have a primary function assigned to it. The primary function is reserved for eTPU_C for compatibility with future devices. |
| ETPUC3_GPIO444 | This pin does not have a primary function assigned to it. The primary function is reserved for eTPU_C for compatibility with future devices. |
| ETPUC4_GPIO445 | This pin does not have a primary function assigned to it. The primary function is reserved for eTPU_C for compatibility with future devices. |
| ETPUC5_GPIO446 | This pin does not have a primary function assigned to it. The primary function is reserved for eTPU_C for compatibility with future devices. |
| ETPUC6_GPIO447 | This pin does not have a primary function assigned to it. The primary function is reserved for eTPU_C for compatibility with future devices. |
| ETPUC7_GPIO448 | This pin does not have a primary function assigned to it. The primary function is reserved for eTPU_C for compatibility with future devices. |
| ETPUC8_GPIO449 | This pin does not have a primary function assigned to it. The primary function is reserved for eTPU_C for compatibility with future devices. |
| ETPUC9_ $\overline{\text{IRQ0}}$ _GPIO450 | This pin does not have a primary function assigned to it. The alternate function is an external interrupt request input for the SIU module. |
| ETPUC10_ $\overline{\text{IRQ1}}$ _GPIO451 | This pin does not have a primary function assigned to it. The alternate function is an external interrupt request input for the SIU module. |
| ETPUC11_ $\overline{\text{IRQ2}}$ _GPIO452 | This pin does not have a primary function assigned to it. The alternate function is an external interrupt request input for the SIU module. |
| ETPUC12_ $\overline{\text{IRQ3}}$ _GPIO453 | This pin does not have a primary function assigned to it. The alternate function is an external interrupt request input for the SIU module. |
| ETPUC13_ $\overline{\text{IRQ4}}$ _GPIO454 | This pin does not have a primary function assigned to it. The alternate function is an external interrupt request input for the SIU module. |
| ETPUC14_ $\overline{\text{IRQ5}}$ _GPIO455 | This pin does not have a primary function assigned to it. The alternate function is an external interrupt request input for the SIU module. |
| ETPUC15_GPIO456 | This pin does not have a primary function assigned to it. |

¹ These signal names include eTPU_C functionality that this device does not have. This is for forward compatibility with devices that have an eTPU_C.

3.3.3 eMIOS Signals

Table 3-7. eMIOS Signals

| Signal Name | Description |
|---------------------------------------|--|
| EMIOS[0:9]_ETPUA[0:9]_GPIO[179:188] | EMIOS[0:9]_ETPUA[0:9]_GPIO[179:188] is an input/output channel pin for the eMIOS module. The alternate functions are output channels for the eTPU A module; that is, when configured as ETPUA[0:9], the pins function as outputs only. |
| EMIOS10_SCKD_GPIO189 | EMIOS10_SCKD_GPIO189 is an input/output channel pin for the eMIOS module. The alternate function is a DSPI clock pin for the DSPI D module. |
| EMIOS11_SIND_GPIO190 | EMIOS11_SIND_GPIO190 is an input/output channel pin for the eMIOS module. The alternate function is a data input pin for the DSPI D module |
| EMIOS12_SOUTC_GPIO191 | EMIOS[12]_SOUTC_GPIO[191] is an output channel pin for the eMIOS module. The alternate function is the data output signal for the DSPI C module. |
| EMIOS13_SOUTD_GPIO192 | EMIOS[13]_SOUTD_GPIO[192] is an output channel pin for the eMIOS module. The alternate function is the data output signal for the DSPI D module. |
| EMIOS14_IRQ0_GPIO193 | EMIOS[14]_IRQ[0]_GPIO[193] is an output channel pin for the eMIOS module. The alternate function is an external interrupt request input. |
| EMIOS15_IRQ1_GPIO194 | EMIOS[15]_IRQ[1]_GPIO[194] is an output channel pin for the eMIOS module. The alternate function is an external interrupt request input. |
| EMIOS[16:23]_ETPUB[0:7]_GPIO[195:202] | Output channel pins for the eMIOS module. Alternate function is an eTPU B output channel |
| EMIOS24_PCSB0_GPIO203 | Output channel pins for the eMIOS module. Alternate function peripheral chip select for the DSPI B module. |
| EMIOS25_PCSB1_GPIO204 | Output channel pins for the eMIOS module. Alternate function peripheral chip select for the DSPI B module. |
| EMIOS26_PCSB2_GPIO432 | Output channel pins for the eMIOS module. Alternate function peripheral chip select for the DSPI B module. |
| EMIOS27_PCSB3_GPIO433 | Output channel pins for the eMIOS module. Alternate function peripheral chip select for the DSPI B module. |
| EMIOS28_PCSC0_GPIO434 | Output channel pins for the eMIOS module. Alternate function peripheral chip select for the DSPI C module. |
| EMIOS29_PCSC1_GPIO435 | Output channel pins for the eMIOS module. Alternate function peripheral chip select for the DSPI C module. |
| EMIOS30_PCSC2_GPIO436 | Output channel pins for the eMIOS module. Alternate function peripheral chip select for the DSPI C module. |
| EMIOS31_PCSC5_GPIO437 | Output channel pins for the eMIOS module. Alternate function peripheral chip select for the DSPI C module. |

3.3.4 eQADC Signals

Table 3-8. eQADC Signals

| Signal Name | Description |
|-------------|--|
| ANA0–ANA23 | ANA[n] is an analog input to eQADC_A's converter pair. |
| AN24–AN39 | AN[n] is an analog input that goes to both eQADC's converter pairs. |
| ANB0–ANB23 | ANB[n] is an analog input to eQADC_B's converter pair. |
| VRH_A | V _{RHA} is the voltage reference high input pin for the eQADC_A. |
| VRL_A | V _{RLA} is the voltage reference low input pin for the eQADC_A. |
| VRH_B | V _{RHB} is the voltage reference high input pin for the eQADC_B. |
| VRL_B | V _{RLB} is the voltage reference low input pin for the eQADC_B. |
| REFBYPCB | REFBYPCB is a bypass capacitor input for the eQADC_B. The REFBYPCB pin is used to connect an external bias capacitor between the REFBYPCB pin and V _{RLB} . The value of this capacitor must be 100nF. This bypass capacitor is used to provide a stable reference voltage for the ADC. |
| REFBYPCA | REFBYPCA is a bypass capacitor input for the eQADC_A. The REFBYPCA pin is used to connect an external bias capacitor between the REFBYPCA pin and V _{RLA} . The value of this capacitor must be 100nF. This bypass capacitor is used to provide a stable reference voltage for the ADC. |
| VDDA_A0 | V _{DDA_n} is the analog supply input pin for the eQADC_A. |
| VDDA_A1 | V _{DDA_n} is the analog supply input pin for the eQADC_A. |
| REFBYPCA1 | REFBYPCA1 is a bypass capacitor input for the eQADC_A. The REFBYPCA1 pin is used to connect an external bias capacitor providing a stable reference voltage for the ADC. |
| VSSA_A1 | V _{SSA_n} is the analog ground reference input pin for the eQADC_A. |
| VDDA_B0 | V _{DDA_n} is the analog supply input pin for the eQADC_B. |
| VDDA_B1 | V _{DDA_n} is the analog supply input pin for the eQADC_B. |
| VSSA_B0 | V _{SSA_n} is the analog ground reference input pin for the eQADC_B. |
| REFBYPCB1 | REFBYPCB1 is a bypass capacitor input for the eQADC_B. The REFBYPCB1 pin is used to connect an external bias capacitor providing a stable reference voltage for the ADC. |

3.3.5 FlexRay Signals

Table 3-9. FlexRay Signals

| Signal Name | Description |
|--------------------|--|
| FR_A_TX_GPIO248 | FlexRay Channel A transmit pin. |
| FR_A_RX_GPIO249 | FlexRay Channel A receive pin. |
| FR_A_TX_EN_GPIO250 | FlexRay Channel A transmit enable pin. |
| FR_B_TX_GPIO251 | FlexRay Channel B transmit pin. |
| FR_B_RX_GPIO252 | FlexRay Channel B receive pin. |
| FR_B_TX_EN_GPIO253 | FlexRay Channel B transmit enable pin. |

Table 3-9. FlexRay Signals (continued)

| Signal Name | Description |
|---|--|
| ETPUC16_FR_A_TX_GPIO45 ¹ | This pin does not have a primary function assigned to it. The alternate function is FlexRay Channel A transmit. |
| ETPUC17_FR_A_RX_GPIO458 ¹ | This pin does not have a primary function assigned to it. The alternate function is FlexRay Channel A receive. |
| ETPUC18_FR_A_TX_EN_GPIO459 ¹ | This pin does not have a primary function assigned to it. The alternate function is FlexRay Channel A transmit enable. |

¹ This signal name includes eTPU_C functionality that this device does not have. This is for forward compatibility with devices that have an eTPU_C.

3.3.6 FlexCAN Signals

Table 3-10. FlexCAN Signals

| Signal Name | Description |
|--------------------|---|
| CNTXA_TXDA_GPIO83 | Transmit pin for the FlexCAN A module. Alternate function is the transmit pin for the eSCI A module |
| CNRXA_RXDA_GPIO84 | Receive pin for the FlexCAN A module. Alternate function is the receive pin for the eSCI A module |
| CNTXB_PCSC3_GPIO85 | Transmit pin for the FlexCAN B module. Alternate function is a peripheral chip select output for the DSPI C module. |
| CNRXB_PCSC4_GPIO86 | Receive pin for the FlexCAN B module. Alternate function is a peripheral chip select output for the DSPI C module. |
| CNTXC_PCSD3_GPIO87 | Transmit pin for the FlexCAN C module. Alternate function is a peripheral chip select output for the DSPI C module. |
| CNRXC_PCSD4_GPIO88 | Receive pin for the FlexCAN C module. Alternate function is a peripheral chip select output for the DSPI C module. |
| CNTXD_GPIO246 | Transmit pin for the FlexCAN D module. |
| CNRXD_GPIO247 | Receive pin for the FlexCAN D module. |

3.3.7 eSCI Signals

Table 3-11. eSCI Signals

| Signal Name | Description |
|-------------------|---|
| TXDA_GPIO89 | Transmit data pin for the eSCI A module. |
| RXDA_GPIO90 | Receive pin for the eSCI A module. |
| TXDB_PCSD1_GPIO91 | Transmit data pin for the eSCI B module. The alternate function is a peripheral chip select output for the DSPI D module. |
| RXDB_PCSD5_GPIO92 | Receive pin for the eSCI B module. The alternate function is a peripheral chip select output for the DSPI D module. |

Table 3-11. eSCI Signals (continued)

| Signal Name | Description |
|-----------------------------------|--|
| TXDC_ETRIG0_GPIO244 | Transmit data pin for the eSCI C module. The alternate function is external trigger signal to trigger a software or hardware event. The eQADC can detect rising edge, falling edge, high level, and low level on each of the external trigger signals. The eQADC also supports configurable digital filters for these external trigger signals. The eQADC external trigger input pins can be connected to the eTPU, the eMIOS, or an external signal. The source is selected by configuring the eQADC trigger source in the SIU_ISEL4-7 registers. ETRIG[0] is the external trigger for CFIFO0, CFIFO2, and CFIFO4 |
| RXDC_GPIO245 | Receive pin for the eSCI C module. |
| ETPUC19_TXDA_GPIO460 ¹ | This pin does not have a primary function assigned to it. The alternate function is the transmit pin for the eSCI A module |
| ETPUC20_RXDA_GPIO461 ¹ | This pin does not have a primary function assigned to it. The alternate function is the receive pin for the eSCI A module |
| ETPUC21_TXDB_GPIO462 ¹ | This pin does not have a primary function assigned to it. The alternate function is the transmit pin for the eSCI B module |
| ETPUC22_RXDB_GPIO463 ¹ | This pin does not have a primary function assigned to it. The alternate function is the receive pin for the eSCI B module |

¹ This signal name includes eTPU_C functionality that this device does not have. This is for forward compatibility with devices that have an eTPU_C.

3.3.8 DSPI Signals

Table 3-12. DSPI Signals

| Signal Name | Description |
|----------------------|---|
| SCKA_PCSC1_GPIO93 | SPI clock pin for the DSPI A module. The alternate signal function is a peripheral chip select for the DSPI C module |
| SINA_PCSC2_GPIO94 | Data input pin for the DSPI A module. The alternate signal function is a peripheral chip select for the DSPI C module |
| SOUTA_PCSC5_GPIO95 | Data output pin for the DSPI A module. The alternate signal function is a peripheral chip select for the DSPI C module |
| PCSA0_PCSD2_GPIO96 | Peripheral chip select for the DSPI A module. The alternate signal function is a peripheral chip select for the DSPI D module |
| PCSA1_GPIO97 | Peripheral chip selects for the DSPI A module. |
| PCSA2_GPIO98 | |
| PCSA3_GPIO99 | |
| PCSA4_GPIO100 | |
| PCSA5_ETRIG1_GPIO101 | Peripheral chip select for the DSPI A module. Alternate function is external trigger signal to trigger a software or hardware event. The eQADC can detect rising edge, falling edge, high level, and low level on each of the external trigger signals. The eQADC also supports configurable digital filters for these external trigger signals. The eQADC external trigger input pins can be connected to the eTPU, the eMIOS, or an external signal. The source is selected by configuring the eQADC trigger source in the SIU_ISEL4-7 registers. ETRIG[1] serves as the external trigger for CFIFO1, CFIFO3, and CFIFO5. |

Table 3-12. DSPI Signals (continued)

| Signal Name | Description |
|------------------------------------|---|
| SCKB_GPIO102 | SPI clock pin for the DSPI B module. |
| SINB_GPIO103 | Data input pin for the DSPI B module. |
| SOUTB_GPIO104 | Data output pin for the DSPI B module. |
| PCSB0_PCSD2_GPIO105 | Peripheral chip select for the DSPI B module. The alternate function is peripheral chip select for the DSPI D module. |
| PCSB1_PCSD0_GPIO106 | Peripheral chip select for the DSPI B module. The alternate function is peripheral chip select for the DSPI D module. |
| PCSB2_SOUTC_GPIO107 | Peripheral chip select for the DSPI B module. The alternate function is data output pin for the DSPI C module |
| PCSB3_SINC_GPIO108 | Peripheral chip select for the DSPI B module. The alternate function is data input pin for the DSPI C module. |
| PCSB4_SCKC_GPIO109 | Peripheral chip select for the DSPI B module. The alternate function is SPI clock pin for the DSPI C module. |
| PCSB5_PCSC0_GPIO110 | Peripheral chip select for the DSPI B module. The alternate function is peripheral chip select for the DSPI C module. |
| SCKC_SCK_C_LVDSP_GPIO235 | SPI clock pin for the DSPI C module. The alternate function is the LVDS+ version of SCKC. |
| SINC_SCK_C_LVDSM_GPIO236 | Data input pin for the DSPI C module. The alternate function is the LVDS- version of SCKC. |
| SOUTC_SOUT_C_LVDSP_GPIO237 | Data output pin for the DSPI C module. The alternate function is the LVDS+ version of SOUTC. |
| PCSC0_SOUT_C_LVDSM_GPIO238 | Peripheral chip select for the DSPI C module. The alternate function is the LVDS- version of SOUTC |
| PCSC1_GPIO239 | Peripheral chip select for the DSPI B module. |
| PCSC2_GPIO240 | Peripheral chip select for the DSPI B module. |
| PCSC3_GPIO241 | Peripheral chip select for the DSPI B module. |
| PCSC4_GPIO242 | Peripheral chip select for the DSPI B module. |
| PCSC5_GPIO243 | Peripheral chip select for the DSPI B module. |
| ETPUC23_PCSD5_GPIO464 ¹ | This pin does not have a primary function assigned to it. The alternate function is a peripheral chip select for the DSPI D module. |
| ETPUC24_PCSD4_GPIO465 ¹ | This pin does not have a primary function assigned to it. The alternate function is a peripheral chip select for the DSPI D module. |
| ETPUC25_PCSD3_GPIO466 ¹ | This pin does not have a primary function assigned to it. The alternate function is a peripheral chip select for the DSPI D module. |
| ETPUC26_PCSD2_GPIO467 ¹ | This pin does not have a primary function assigned to it. The alternate function is a peripheral chip select for the DSPI D module. |
| ETPUC27_PCSD1_GPIO468 ¹ | This pin does not have a primary function assigned to it. The alternate function is a peripheral chip select for the DSPI D module. |
| ETPUC28_PCSD0_GPIO469 ¹ | This pin does not have a primary function assigned to it. The alternate function is a peripheral chip select for the DSPI D module. |

Table 3-12. DSPI Signals (continued)

| Signal Name | Description |
|------------------------------------|--|
| ETPUC29_SCKD_GPIO470 ¹ | This pin does not have a primary function assigned to it. The alternate function is a DSPI clock pin for the DSPI D module. |
| ETPUC30_SOUTD_GPIO471 ¹ | This pin does not have a primary function assigned to it. The alternate function is a data output pin for the DSPI D module. |
| ETPUC31_SIND_GPIO472 ¹ | This pin does not have a primary function assigned to it. The alternate function is a data input pin for the DSPI D module. |

¹ This signal name includes eTPU_C functionality that this device does not have. This is for forward compatibility with devices that have an eTPU_C.

3.3.9 EBI Signals

Table 3-13. EBI Signals (Development Bus Only)

| Signal Name | Description |
|---|---|
| D_ $\overline{\text{CS}}0$ _GPIO256 | EBI chip select output signal. |
| D_ $\overline{\text{CS}}2$ _D_DAT31_GPIO257 | EBI chip select output signal. The alternate function is data signal 31. |
| D_ $\overline{\text{CS}}3$ _D_ $\overline{\text{TEA}}$ _GPIO258 | EBI chip select output signal. The alternate function is TEA which indicates that an error occurred in the current external bus transfer. |
| D_ADD12_GPIO259 | EBI address signals. |
| D_ADD13_GPIO260 | |
| D_ADD14_GPIO261 | |
| D_ADD15_GPIO262 | |
| D_ADD16_D_DAT16_GPIO263 | EBI address signals with alternate functions of EBI data signals. |
| D_ADD17_D_DAT17_GPIO264 | |
| D_ADD18_D_DAT18_GPIO265 | |
| D_ADD19_D_DAT19_GPIO266 | |
| D_ADD20_D_DAT20_GPIO267 | |
| D_ADD21_D_DAT21_GPIO268 | |
| D_ADD22_D_DAT22_GPIO269 | |
| D_ADD23_D_DAT23_GPIO270 | |
| D_ADD24_D_DAT24_GPIO271 | |
| D_ADD25_D_DAT25_GPIO272 | |
| D_ADD26_D_DAT26_GPIO273 | |
| D_ADD27_D_DAT27_GPIO274 | |
| D_ADD28_D_DAT28_GPIO275 | |
| D_ADD29_D_DAT29_GPIO276 | |
| D_ADD30_D_DAT30_GPIO277 | |
| D_DAT[0:15]_GPIO[278:293] | EBI data signals. |

Table 3-13. EBI Signals (Development Bus Only) (continued)

| Signal Name | Description |
|-------------------------------|---|
| D_RD \overline{WR} _GPIO294 | Indicates whether an external bus transfer is a read or write operation. |
| D $\overline{WE0}$ _GPIO295 | Write/Byte enable specify which data pins contain valid data for an external bus transfer. |
| D $\overline{WE1}$ _GPIO296 | |
| D \overline{OE} _GPIO297 | Output enable indicates that the EBI is ready to accept read data. |
| D \overline{TS} _GPIO298 | Transfer start is asserted by the EBI owner to indicate the start of a transfer. |
| D_ALE_GPIO299 | Address latch enable is used to demultiplex the address from data bus. It is asserted while the least significant 16 bits of the address are present in the multiplexed address/data bus. |
| D \overline{TA} _GPIO300 | Transfer acknowledge is asserted by the EBI owner to acknowledge that the slave has completed the current transfer. |
| D $\overline{CS1}$ _GPIO301 | EBI chip select output signal. |
| D \overline{BDIP} _GPIO302 | Burst Data In Progress indicates that an EBI burst transfer is in progress. |
| D $\overline{WE2}$ _GPIO303 | Write/Byte enable specify which data pins contain valid data for an external bus transfer. |
| D $\overline{WE3}$ _GPIO304 | |
| D_ADD9_GPIO305 | EBI address signals. |
| D_ADD10_GPIO306 | |
| D_ADD11_GPIO307 | |

3.3.10 Reset and Clock Signals

Table 3-14. Reset and Clock Signals

| Signal Name | Description |
|--|--|
| \overline{RESET} | The \overline{RESET} input is asserted by an external device to reset the all modules of the device MCU. The \overline{RESET} pin must be asserted during a power-on reset. |
| \overline{RSTOUT} | The \overline{RSTOUT} output is a push/pull output that is asserted during an internal device reset. The pin can also be asserted by software without causing an internal reset of the device MCU. Note: During a power-on-reset (POR), \overline{RSTOUT} is tri-stated. |
| BOOTCFG[0:1] \overline{IRQ} [2:3] GPIO[211:212] | BOOTCFG[0:1] signals are sampled on every reset. The values are used by the Boot Assist Module (BAM) program to determine the boot configuration of the device. The alternate functions are the external interrupt request inputs (IRQs). |
| WKPCFG_NMI_GPIO213 | WKPCFG (sampled at every reset) determines whether specific eTPU and eMIOS pins are connected to a weak pullup or weak pulldown during and immediately after reset. The alternate function (NMI) is a critical interrupt to the core. |
| PLLCFG0 $\overline{IRQ4}$ _GPIO208 | PLLCFG n are sampled at every reset. These values are used to configure the FMPLL mode of operation. The alternate function is an external interrupt request input. |
| PLLCFG1 $\overline{IRQ5}$ _GPIO209 | PLLCFG n are sampled at every reset. These values are used to configure the FMPLL operation mode. The alternate functions are an external interrupt request input and data output for the DSPI module D. |
| PLLCFG2 | PLLCFG n are sampled at every reset. These values are used to configure the FMPLL operation mode. PLLCFG2 configures the crystal oscillator range. |

Table 3-14. Reset and Clock Signals (continued)

| Signal Name | Description |
|-------------|--|
| XTAL | XTAL is the output pin for an external crystal oscillator. |
| EXTAL | EXTAL is the input pin for an external crystal oscillator or an external clock source. |
| D_CLKOUT | CLKOUT is the device system clock output (for the development EBI). |
| ENGCLK | ENGCLK is a 50% duty cycle output clock with a maximum frequency of the device system clock divided by two. ENGCLK is not synchronous to CLKOUT. |

3.3.11 JTAG and Nexus Signals

Table 3-15. JTAG and Nexus Signals

| Signal Name | Description |
|-------------------------------------|---|
| $\overline{\text{EVTI}}$ | $\overline{\text{EVTI}}$ is an input that is read during a debug port reset to enable or disable the Nexus Auxiliary port for data trace. After reset, the $\overline{\text{EVTI}}$ pin is used to initiate program and data trace synchronization messages or generate a breakpoint. |
| $\overline{\text{EVTO}}$ | $\overline{\text{EVTO}}$ is an output that provides timing to a development tool for a single watchpoint or breakpoint occurrence. The BAM uses this pin to select if auto baud rate is on or off (Section 9.3.4, Serial Boot Mode). |
| MCKO | MCKO is a free running clock output to the development tools which is used for timing of the MDO and $\overline{\text{MSEO}}$ signals. |
| MDO0_GPIO220 ¹ | MDO[0] is a trace message output to the development tools. In addition, MDO[0] indicates the lock status of the system clock following a power-on reset. There is an internal pullup on MDO[0]. This pin functions as GPIO when Nexus messaging is disabled. |
| MDO[3:1]_GPIO[223:221] ¹ | MDO[3:1] are the trace message outputs to the development tools for reduced port mode. These pins function as GPIO when Nexus messaging is disabled. |
| MDO[11:4]_GPIO[82:75] ¹ | MDO[11:4] are the trace message outputs to the development tools for reduced port mode. These pins function as GPIO when Nexus messaging is disabled. |
| MDO[15:12]_GPIO[234:231] | Trace message outputs to the development tools for full port mode. These pins function as GPIO when the Nexus Development Interface (NDI) functions in reduced port mode or when Nexus messaging is disabled. |
| $\overline{\text{MSEO}}[1:0]$ | $\overline{\text{MSEO}}[1:0]$ are output signals that indicate when messages start and end on the MDO pins. |
| $\overline{\text{RDY}}$ | $\overline{\text{RDY}}$ is an output signal that indicates to the development tools the data is ready to be read from or written to the Nexus read/write access registers. |
| TCK | TCK provides the clock input for the on-chip test logic. |
| TDI | TDI provides the serial test instruction and data input for the on-chip test logic. |
| TDO | TDO provides the serial test data output for the on-chip test logic. |
| TMS | TMS controls test mode operations for the on-chip test logic. |
| JCOMP | JCOMP enables the JTAG TAP controller. |
| TEST | TEST places the chip into test mode. You must tie this pin to VSS. |

¹ GPIO function for MDO[11:0] is only available on Rev.2 of the device. Do not connect pin directly to a power supply or ground.

3.3.12 PMC and Power/Voltage Signals

Table 3-16. PMC and Power/Voltage Signals

| Signal Name | Description |
|--|---|
| REGSEL | Selects PMC regulator mode (Linear/Switch mode). |
| REGCTL | Core voltage regulator output control pin to the external bipolar/MOS transistor. |
| VDDSYN | V_{DDSYN} is the power supply input for the FMPLL. It is also the 3.3V regulator output, when enabled (see the PMC chapter). |
| VSSSYN | V_{SSSYN} is the ground reference input for the FMPLL. |
| VDD33 | IO pre-drivers and flash power supply. |
| VSTBY | V_{STBY} is the power supply input that is used to maintain a portion of the contents of internal SRAM during power down. If not used, tie V_{STBY} to V_{SS} . |
| VSSFL | VSSFL must be tied to V_{SS} . |
| VDDREG | Source voltage for on-chip regulators and low voltage detect (LVD) circuits. |
| VDDEH _n , VDDE _n | I/O supply input. |
| VRH_A | V_{RHA} is the voltage reference high input pin for the eQADC_A. |
| VRL_A | V_{RLA} is the voltage reference low input pin for the eQADC_A. |
| VRH_B | V_{RHB} is the voltage reference high input pin for the eQADC_B. |
| VRL_B | V_{RLB} is the voltage reference low input pin for the eQADC_B. |
| VDDA_A0 | V_{DDA_n} is the analog supply input pin for the eQADC_A. |
| VDDA_A1 | V_{DDA_n} is the analog supply input pin for the eQADC_A. |
| VSSA_A1 | V_{SSA_n} is the analog ground reference input pin for the eQADC_A. |
| VDDA_B0 | V_{DDA_n} is the analog supply input pin for the eQADC_B. |
| VDDA_B1 | V_{DDA_n} is the analog supply input pin for the eQADC_B. |
| VSSA_B0 | V_{SSA_n} is the analog ground reference input pin for the eQADC_B. |



Chapter 4

Resets

NOTE

Throughout this text the phrase “reset configuration pins” is used to refer to WKPCFG, BOOTCFG, and PLLCFG pins.

Not all packages have BOOTCFG[0]. In this case, BOOTCFG[0] is sampled as 0b0.

4.1 Reset Sources

This device supports the following system reset sources:

- Power-on Reset
- External Reset
- Loss of Lock Reset
- Loss of Clock Reset
- Watchdog Timer/Debug Reset
- JTAG Reset
- Software System Reset

All reset sources are processed by the reset controller, which monitors the reset input sources, and upon detection of a reset event, resets internal logic and controls the assertion of the $\overline{\text{RSTOUT}}$ pin. The Software External Reset only causes the $\overline{\text{RSTOUT}}$ pin to be asserted for a number of clock cycles determined by the PLL mode (refer to [Section 4.3.2, RSTOUT](#)), and does not reset the device.

For all reset sources, the BOOTCFG[0:1] and PLLCFG[0:2] signals are used to determine the boot mode and configuration of the FMPLL, respectively. [Table 4-1](#) shows the options for BOOTCFG[0:1] and [Table 4-2](#) for PLLCFG[0:2]. Refer to [Chapter 6, Frequency Modulated Phase-Locked Loop \(FMPLL\)](#), for information on the FMPLL during reset.

Table 4-1. BOOTCFG Options

| BOOTCFG[0] | BOOTCFG[1] | Meaning |
|------------|------------|--|
| 0 | 0 | Boot from internal flash memory |
| 0 | 1 | FlexCAN / eSCI boot |
| 1 | 0 | Boot from external memory ¹ |
| 1 | 1 | Boot from external memory ¹ |

¹ This mode is only available in packages that have an EBI.

Table 4-2. PLLCFG Options

| Package Pins ¹ | | Clock Mode |
|---------------------------|-----------|-------------------------------------|
| PLLCFG[0] | PLLCFG[1] | |
| 0 | 0 | PLL Off mode |
| 0 | 1 | Normal mode with external reference |
| 1 | 0 | Normal mode with crystal reference |
| 1 | 1 | Reserved |

¹ The PLLCFG[2] pin configures the crystal oscillator range:
 PLLCFG[2] = 0, for 8 MHz to 20 MHz
 PLLCFG[2] = 1, for 40 MHz

The Reset Status Register (SIU_RSR) gives the source, or sources, of the last reset and indicates whether a glitch has occurred on the $\overline{\text{RESET}}$ pin. The SIU_RSR is updated for all reset sources except JTAG reset.

All reset sources initiate execution of the Boot Assist Module (BAM) program with the exception of the Software External Reset.

The Reset Configuration Half Word (RCHW) determines the MCU configuration after reset. The RCHW is stored in internal flash, or a default configuration is used. During reset, the RCHW is read from internal flash memory. The BOOTCFG[0:1]¹ pins are defined in [Chapter 7, System Integration Unit \(SIU\)](#). The BAM program reads the value of the BOOTCFG[0:1] pins from the BOOTCFG field of the SIU_RSR, then reads the RCHW from the specified location, and then uses the RCHW value to determine and execute the specified boot procedure. Note: the reset controller latches the value on the BOOTCFG input to the SIU 4 clock cycles prior to the negation of $\overline{\text{RSTOUT}}$.

4.2 Reset Vector

The reset vector for this device is 0xFFFF_FFFC. This is a fixed location in the BAM. The BAM program executes after every internal reset. The BAM program determines where to branch after its execution completes based on the value on the BOOTCFG[0:1] pins. See the BAM chapter's functional description for details on the BAM program operation and branch location to application software.

4.3 Reset Pins

4.3.1 $\overline{\text{RESET}}$

The $\overline{\text{RESET}}$ pin is an active low input. The $\overline{\text{RESET}}$ pin must be asserted by an external device during a power-on or whenever an external reset is required. The internal reset signal asserts only if the $\overline{\text{RESET}}$ pin asserts for 10 clock cycles. Assertion of the $\overline{\text{RESET}}$ pin while the reset state machine is already processing a reset causes the reset cycle to start over. The $\overline{\text{RESET}}$ pin has a glitch detector which detects spikes greater than 2 clocks in duration that fall below the switch point of the input buffer logic of the VDDEH input

1. BOOTCFG[0] is not available on all packages.

pins. The switch point lies between the maximum VIL and minimum VIH specifications for the VDDEH input pins. [Figure 4-1](#) and [Figure 4-2](#) show logic flows of the reset state machine on assertion of $\overline{\text{RESET}}$.

4.3.2 $\overline{\text{RSTOUT}}$

The $\overline{\text{RSTOUT}}$ pin is an active low output that uses a push/pull configuration. The $\overline{\text{RSTOUT}}$ pin is driven to the low state by the MCU for all internal and external reset sources.

If the PLL is configured for normal mode, the $\overline{\text{RSTOUT}}$ pin is asserted for 2400 clock cycles, plus 4 cycles for sampling of the configuration pins. See [Table 4-3](#) for other source values.

The $\overline{\text{RSTOUT}}$ pin can also be asserted by a write to the SER bit of the System Reset Control Register (SIU_SRCR); however no system reset occurs under this circumstance.

Table 4-3. Clock Cycles for Different Reset Sources

| Source | Description | Number of clock cycles (short count) ¹ | Number of clock cycles (long count) ² |
|----------|-------------------------------|---|--|
| SIU_POR | Power On Reset | 2400 | 16000 |
| SIU_ER | External Reset (RESET pin) | 2410 | 16100 |
| SIU_LLR | Loss of Lock Reset | 2420 | 16200 |
| SIU_WTR | Watchdog Timer Reset | 2430 | 16300 |
| SIU_CR | Core Reset | 2440 | 16400 |
| SIU_SWTR | Software Watchdog Timer Reset | 2450 | 16500 |
| SIU_LCR | Loss of Clock Reset | 2460 | 16600 |
| SIU_SSR | Software System Reset | 2470 | 16700 |
| SIU_SER | Software External Reset | 2480 | 16800 |

¹ Used in the XOSC and XREF modes.

² Used in the bypass and 1:1 modes.

4.4 FMPLL Lock Gating Signal

The FMPLL Loss of Lock reset request is connected to both a reset request and a reset gating signal in the SIU. The FMPLL asserts the Loss of Lock reset request until the PLL has achieved lock.

4.5 Reset Source Descriptions

For the following reset source descriptions refer to the reset flow diagrams in [Figure 4-1](#) and [Figure 4-2](#). [Figure 4-1](#) shows the reset flow for assertion of the $\overline{\text{RESET}}$ pin. [Figure 4-2](#) shows the internal processing of reset for all reset sources.

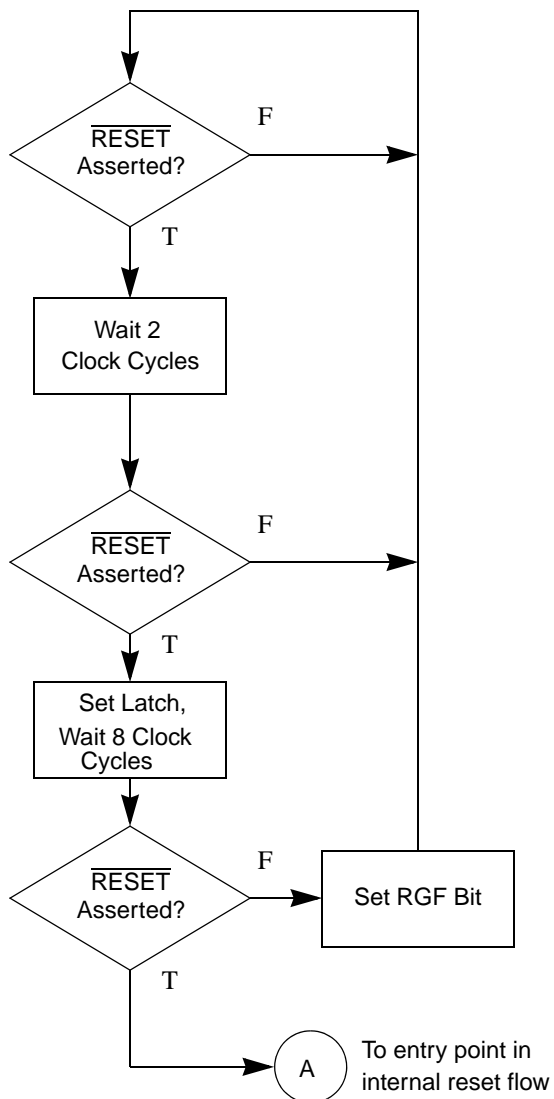
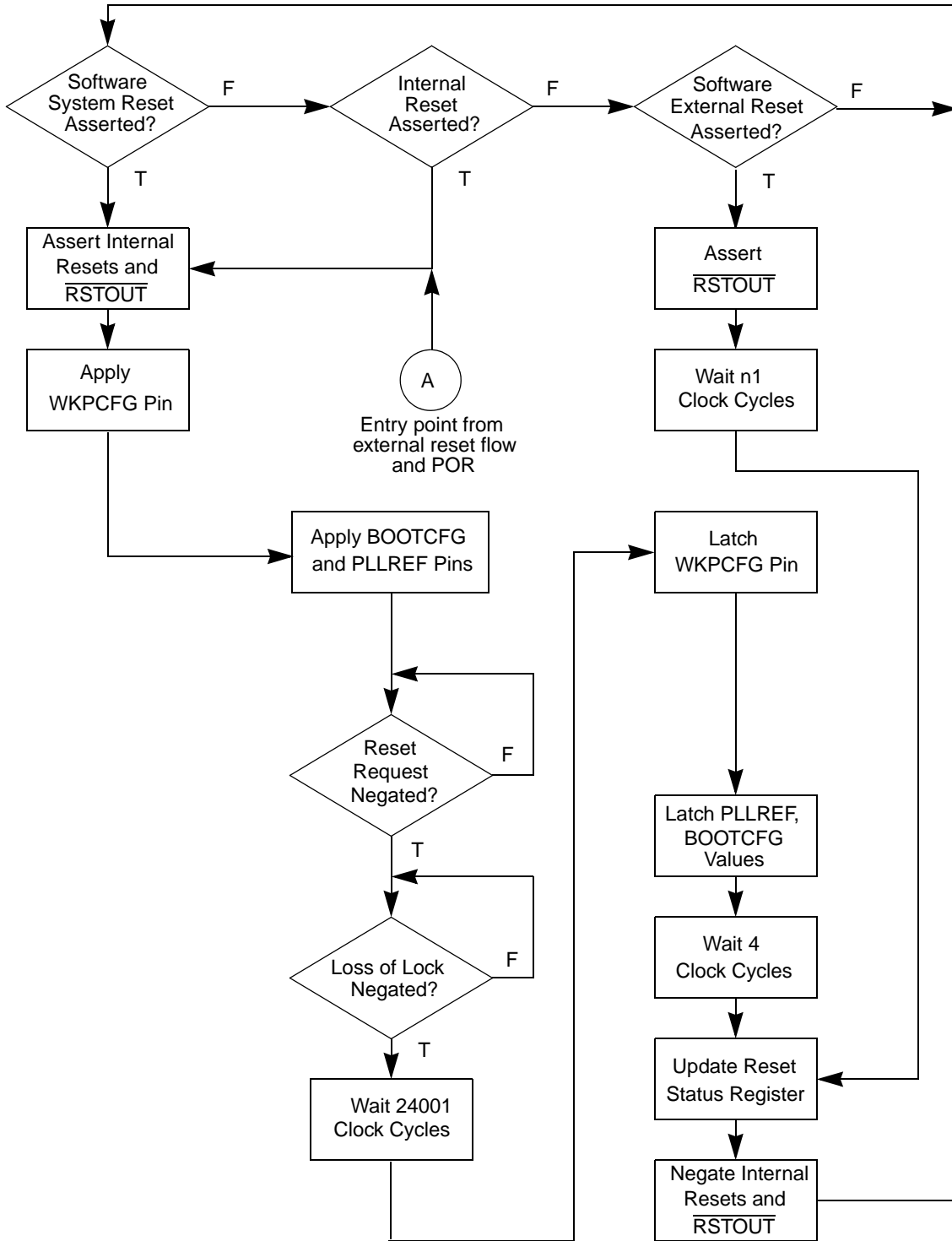

Figure 4-1. External Reset Flow Diagram



NOTES:

1. The clock count is dependent on the configuration of the PLL (refer to [Section 4.3.2, RSTOUT](#)).

Figure 4-2. Internal Reset Flow Diagram

4.5.1 Power-on Reset (POR)

The internal power-on reset signal is asserted when either the supply voltages, nominally 3.3V (VDD33) and 1.2V (VDD) or the $\overline{\text{RESET}}$ supply (VDDEH1) fall below defined threshold voltages. See the device data sheet for the specifications of these thresholds. The PMC provides additional software-configurable registers for masking of POR assertions based on these and additional supplies. See the PMC chapter for details. Although assertion of the power-on reset signal causes reset, the $\overline{\text{RESET}}$ pin must be asserted during a power-on reset to guarantee proper operation of the MCU.

The system clock source is determined during reset as shown in [Table 6-13](#) (FMPLL chapter). The value of the PLLCFG[0:1] pins are latched during reset. If PLLCFG[0:1] are changed during a reset other than power-on reset, the internal clocks may glitch as the clock source is changed between PLL Off mode and PLL clock mode or from one PLL clock mode to another. Whenever PLLCFG[0:1] are changed in reset to a value other than what it was before the reset, an immediate loss of lock condition is declared. This only applies if the PLL was running in a locked state prior to the assertion of reset and change of PLLCFG[0:1].

The signal on the WKPCFG pin determines whether weak pull up or pull down devices are enabled after reset on the eTPU and eMIOS pins. The WKPCFG pin is applied on the assertion of the internal reset signal (assertion of $\overline{\text{RSTOUT}}$). See [Section 4.7.3, Reset Weak Pull Up/Down Configuration](#), for more information.

Once the $\overline{\text{RESET}}$ input pin is negated the reset controller checks the FMPLL Loss of Lock reset request signal. The internal reset signal and $\overline{\text{RSTOUT}}$ are kept asserted until the FMPLL negates the Loss of Lock reset request signal. After the Loss of Lock reset request signal is negated, the reset controller waits for a predetermined number of clock cycles (refer to [Section 4.3.2, RSTOUT](#)) before negating the $\overline{\text{RSTOUT}}$ pin. The reset configuration pins are sampled 4 clock cycles before the negation of $\overline{\text{RSTOUT}}$, and the associated bits/fields are updated in the SIU_RSR. In addition, the PORS and ERS bits are set, and all other reset status bits are cleared in the Reset Status Register.

4.5.2 External Reset

When the reset controller detects assertion of the $\overline{\text{RESET}}$ pin, the internal reset signal and $\overline{\text{RSTOUT}}$ pin are asserted. The values on the WKPCFG pin and PLLCFG pins are applied at the assertion of the internal reset signal (assertion of $\overline{\text{RSTOUT}}$). Once the $\overline{\text{RESET}}$ pin is negated and the FMPLL Loss of Lock reset request signal is negated, the reset controller waits for a predetermined number of clock cycles (refer to [Section 4.3.2, RSTOUT](#)). Once the clock count finishes, the reset configuration pins are latched. The reset controller then waits 4 clock cycles before negating $\overline{\text{RSTOUT}}$, and the associated bits/fields are updated in the SIU_RSR. In addition, the ERS bit is set, and all other reset status bits in the SIU_RSR are cleared.

4.5.3 Loss of Lock

A Loss of Lock Reset occurs when the FMPLL loses lock and the Loss of Lock Reset Enable (LOLRE) bit in the FMPLL Synthesizer Control Register (ESYNCR2) is set. The internal reset signal and $\overline{\text{RSTOUT}}$ pin are asserted. The values on the WKPCFG and PLLCFG pins are applied at the assertion of the internal reset signal (assertion of $\overline{\text{RSTOUT}}$). Once the FMPLL Loss of Lock reset request signal is negated, the reset controller waits for a predetermined number of clock cycles (refer to [Section 4.3.2, RSTOUT](#)). Once

the clock count finishes, the reset configuration pins are sampled. The reset controller then waits 4 clock cycles before negating $\overline{\text{RSTOUT}}$, and the associated bits/fields are updated in the SIU_RSR. In addition, the LLRS bit is set, and all other reset status bits in the SIU_RSR are cleared. Refer to [Section 6.4.3.1, PLL Lock Detection](#), in the FMPLL chapter for more information on loss of lock.

4.5.4 Loss of Clock

A Loss of Clock Reset occurs when a failure in either the reference signal or FMPLL output, and the Loss of Clock Reset Enable (LOCRE) bit in the ESYNCR2 is set. The internal reset signal and $\overline{\text{RSTOUT}}$ pin are asserted. The value on the WKPCFG and PLLCFG pins are applied at the assertion of the internal reset signal (assertion of $\overline{\text{RSTOUT}}$). Once the Loss of Clock and Loss of Lock reset request signals are negated, the reset controller waits for a predetermined number of clock cycles (refer to [Section 4.3.2, RSTOUT](#)). Once the clock count finishes, the reset configuration pins are sampled. The reset controller then waits 4 clock cycles before negating $\overline{\text{RSTOUT}}$, and the associated bits/fields are updated in the SIU_RSR. In addition, the LCRS bit is set, and all other reset status bits in the SIU_RSR are cleared. Refer to [Section 6.4.3.2, Loss-of-Clock Detection](#), in the FMPLL chapter for more information on loss of clock.

4.5.5 Core Watchdog Timer/Debug Reset

There are two watchdog timer resets: A core watchdog and a platform watchdog.

A Core Watchdog Timer Reset occurs when the e200z7 core watchdog timer is enabled (the e200z7 core watchdog is counting core clocks, which is different than the peripheral/platform clocks), and a time-out occurs with the Enable Next Watchdog Timer (EWT) and Watchdog Timer Interrupt Status (WIS) bits set in the Timer Status Register, and with the Watchdog Reset Control (WRC) field in the Timer Control Register configured for a reset. The WDRS bit in the SIU_RSR is also set when a debug reset command is issued from a debug tool. To determine whether the WDRS bit was set due to a Watchdog Timer or Debug Reset, see the WRS field in the e200z7 core Timer Status Register.

The effect of a Watchdog Timer or Debug Reset request is the same for the reset controller. The internal reset signal and $\overline{\text{RSTOUT}}$ pin are asserted. The value on the WKPCFG pin is applied at the assertion of the internal reset signal (assertion of $\overline{\text{RSTOUT}}$), as is the PLLREF value. Once the Watchdog Timer/Debug reset request is negated and the FMPLL Loss of Lock reset request signal is negated, the reset controller waits for a predetermined number of clock cycles (refer to [Section 4.3.2, RSTOUT](#)). Once the clock count finishes the reset configuration pins are sampled. The reset controller then waits 4 clock cycles before negating $\overline{\text{RSTOUT}}$, and the associated bits/fields are updated in the SIU_RSR. In addition, the WTRS bit is set, and all other reset status bits in the SIU_RSR are cleared.

Refer to the *e200z7 Core Reference Manual* for more information on the core watchdog timer and debug operation. Refer to [Chapter 18, Software Watchdog Timer \(SWT\)](#), for more information on the platform watchdog.

4.5.6 JTAG Reset

A system reset occurs when JTAG is enabled and either the EXTEST, CLAMP, or HIGHZ instructions are executed by the JTAG controller. The internal reset signal is asserted. The state of the $\overline{\text{RSTOUT}}$ pin is determined by the JTAG instruction. The values on the WKPCFG and PLLCFG pins are applied at the

assertion of the internal reset signal. Once the JTAG reset request is negated and the FMPLL Loss of Lock reset request signal is negated, the reset controller waits for a predetermined number of clock cycles (refer to [Section 4.3.2, RSTOUT](#)). Once the clock count finishes the reset configuration pins are sampled, and the associated bits/fields are updated in the SIU_RSR. The reset status bits in the SIU_RSR are unaffected. Refer to [Chapter 32, IEEE 1149.1 Test Access Port Controller \(JTAGC\)](#), for more information.

4.5.7 Software System Reset

A Software System Reset is caused by a write to the SSR bit in the System Reset Control Register (SIU_SRCR), [Section 7.3.1.3, System Reset Control Register \(SIU_SRCR\)](#). A write of one to the SSR bit causes an internal reset of the MCU. The internal reset signal and $\overline{\text{RSTOUT}}$ pin are asserted. The value on the WKPCFG pin is applied at the assertion of the internal reset signal (assertion of $\overline{\text{RSTOUT}}$), as is the PLLREF value. The SSR bit is automatically cleared and once the FMPLL Loss of Lock reset request signal is negated, the reset controller waits for a predetermined number of clock cycles (refer to [Section 4.3.2, RSTOUT](#)). Once the clock count finishes the reset configuration pins are sampled. The reset controller then waits 4 clock cycles before negating $\overline{\text{RSTOUT}}$, and the associated bits/fields are updated in the SIU_RSR. In addition, the SSRS bit is set, and all other reset status bits in the SIU_RSR are cleared.

4.5.8 Software External Reset

A write of one to the SER bit in the SIU_SRCR causes the external $\overline{\text{RSTOUT}}$ pin to be asserted for a predetermined number of clock cycles (refer to [Section 4.3.2, RSTOUT](#)). The SER bit automatically clears after the clock counting expires. A Software External Reset does not cause a reset of the MCU, the BAM program is not executed, the reset configuration pins are not sampled. The SERF bit in the SIU_RSR is set, but no other status bits are affected. The SERF bit in the SIU_RSR is not automatically cleared after the 6000 clock cycles expire, and remains set until cleared by software or another reset besides the Software External Reset occurs.

For a Software External Reset, the e200z7 core will continue to execute instructions, timers that are enabled will continue to operate, and interrupt requests will continue to be processed. It is the responsibility of the application to ensure devices connected to $\overline{\text{RSTOUT}}$ are not accessed during a Software External Reset, and to determine how to manage MCU resources when using the Software External Reset.

4.6 Reset Registers in the SIU

The System Integration Unit (SIU) on this device includes two registers, SIU_RSR and SIU_SRCR, that affect the reset behavior of this device. See [Chapter 7, System Integration Unit \(SIU\)](#), for descriptions of these registers.

4.7 Reset Configuration

4.7.1 Reset Configuration Half Word (RCHW)

4.7.1.1 RCHW Overview

The Reset Configuration Half Word (RCHW) defines boot options and must be programmed in a choice of predefined locations in internal flash. The word at the word address boundary after the RCHW must be programmed with the user application's starting address. The BAM passes control to the user application at this starting address.

On every reset except the Software External Reset (SER), in internal or external boot modes, the BAM attempts to read the RCHW from internal or external memory respectively. The locations for the RCHW are given in Table 4-4. For internal boot, the predefined locations are searched in the order given in the table. If a valid RCHW is not found in internal boot mode or in external boot mode, the BAM initiates the serial boot mode. Note that in serial boot mode, a user defined start address must still be supplied as part of the download protocol. Refer to the BAM Chapter for complete details.

Table 4-4. RCHW Location

| Boot Mode | Address |
|-------------|-------------|
| External | 0x0000_0000 |
| Internal | 0x0000_0000 |
| | 0x0000_4000 |
| | 0x0001_0000 |
| | 0x0001_C000 |
| | 0x0002_0000 |
| 0x0003_0000 | |

4.7.1.2 RCHW Structure

When booting from the external flash device, the RCHW must reside in the first 16 bits of memory.

BOOT_BLOCK_ADDRESS + 0x0000_0000

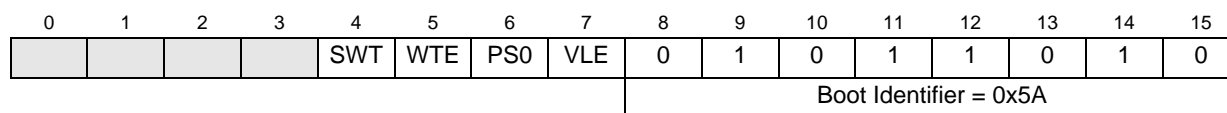

Figure 4-3. Reset Configuration Half Word

The following table describes the fields in the reset configuration halfword:

Table 4-5.

| Field | Description |
|----------------|---|
| 0–3 | Reserved. These bit values are ignored when the halfword is read. Program to 0 for future compatibility. |
| 4 SWT | Software watchdog timer enable. This bit determines if the software watchdog timer is enabled after passing control to the user application code. 0 Disable software watchdog timer 1 Enable software watchdog timer after reset. The timeout period is 261600 system clocks. |
| 5 WTE | MCU core watchdog timer enable. This bit determines if the core software watchdog timer is enabled after passing control to the user application code. 0 Disable core software watchdog timer 1 Enable core watchdog timer after reset. The timeout period is 2.5×2^{17} system clocks. |
| 6 PS0 | Port size. Defines the width of the data bus connected to the memory on D_CS0. After system reset, the BAM changes D_CS0 to a 16-bit port to fetch the RCHW from either 16- or 32-bit external memories. Then the BAM reconfigures the EBI as a 16- or 32-bit port, depending on this bit. 0 32-bit D_CS0 port size 1 16-bit D_CS0 port size Note: Used in development bus boot modes only (not available on all packages). Do not clear this bit if the device only has a 16-bit data bus. |
| 7 VLE | VLE Code Indicator. This bit configures the MMU entries 1-3 coded as Classic Book E instructions or as Freescale VLE instructions. 0 User code executes as classic Book E code 1 User code executes as Freescale VLE code |
| 8–15 BOOTID | Boot identifier. This field serves two functions: <ul style="list-style-type: none"> Indicates which block in flash memory contains the boot program Indicates if the flash memory is programmed (BOOTID=0x5A) or invalid |

When enabled by RCHW[SWT, WTE] bits, the watchdog timeout periods are as shown in [Table 4-6](#).

Note the following:

- The core WD timeout for 20 and 40 MHz crystal is the same because the PLLCFG[2] pin should be set for 40 MHz crystal, which has the effect of doubling the PLL input divider.
- The SWT clock source is directly from the crystal oscillator. The core WD is clocked by the PLL.
- The core WD timeouts reported here correspond to the PLL settings after reset. Core WD timeouts will change as soon as the PLL is programmed with different multipliers.

Table 4-6. Watchdog timeout periods

| Crystal Frequency (MHz) | Core WD Timeout (ms) | SWT Timeout (ms) |
|-------------------------|----------------------|------------------|
| 8 | 27.3 | 49 |
| 12 | 18.3 | 32.7 |
| 16 | 13.7 | 24.5 |
| 20 | 11 | 19.6 |
| 40 | 9.8 | |

4.7.2 Reset Configuration Timing

The timing diagram in [Figure 4-4](#) shows the relationship between reset signals and the configuration pins for a power-on reset. The timing diagram is valid for internal and external resets assuming that VDD and VDD33 are within valid operating ranges. The WKPCFG and PLLCFG signals are applied at the assertion of the internal reset signal (assertion of $\overline{\text{RSTOUT}}$). The values of the configuration pins are latched 4 clock cycles before the negation of the $\overline{\text{RSTOUT}}$ pin and stored in the Reset Status Register and SYNSR register.

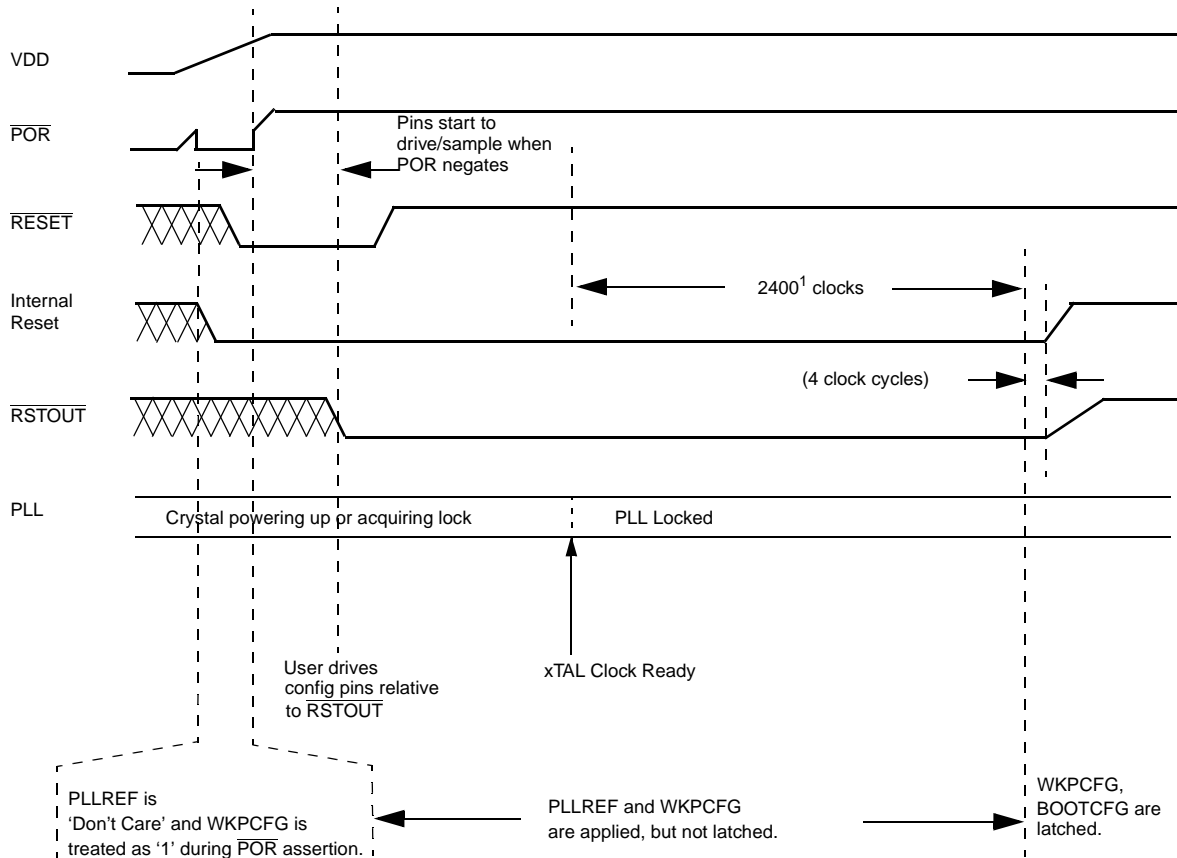

Note: 1. The clock count is dependent on the configuration of the PLL (refer to [Section 4.3.2, RSTOUT](#)). If the PLL is configured in bypass mode, this clock count is 16000.

Figure 4-4. Reset Configuration Timing

4.7.3 Reset Weak Pull Up/Down Configuration

The signal on the WKPCFG pin determines whether specified eTPU and eMIOS pins are connected to weak pull up or weak pull down devices at reset (see the Signal Description chapter for the eTPU and eMIOS pins that are affected by WKPCFG). For all reset sources except the Software External Reset, the WKPCFG pin is applied at the assertion of the internal reset signal (assertion of $\overline{\text{RSTOUT}}$). If the WKPCFG signal is logic high at this time, pull up devices will be enabled on the eTPU and eMIOS pins. If the WKPCFG signal is logic low at the assertion of the internal reset signal, pull down devices will be enabled on those pins. The value on WKPCFG must be held constant during reset to avoid oscillations on

Resets

the eTPU and eMIOS pins caused by switching pull up/down states. The final value of WKPCFG is latched 4 clock cycles before the negation of $\overline{\text{RSTOUT}}$. After reset, software may modify the weak pull up/down selection for all I/O pins through the PCR registers in the SIU.

Chapter 5

Power Management Controller (PMC)

5.1 Introduction

The power management controller (PMC) is compatible with 3.3V or 5V operation. It provides voltage regulation to the microcontroller and includes advanced power on reset (POR) and precision low voltage detector (LVD) monitors that guarantee safe device operation.

5.1.1 Features

The PMC contains the following features (see [Section 5.1.1.1, Analog PMC_SMPS features](#) and [Section 5.1.1.2, Digital PMC_SMPS features](#) for detailed analog and digital features of this device):

- Compatible for both 5V and 3.3V operations.
- A Switched Mode Power Supply (SMPS) Buck regulator and a Low Drop Out (LDO) linear regulator, sharing the same control pin (REGSEL).
- SMPS regulator is selected when the REGSEL pin is connected to VDDREG. A 5V nominal supply voltage is recommended to operate and defines the LVD level to 5V.
- LDO regulator is selected when the REGSEL pin is connected to VSS. A 3V nominal supply voltage is recommended to operate and defines the VDDREG LVD level to 3V.
- High precision Low Voltage Detector (LVD) monitor for PMC supply voltage VDDREG, VDD core voltage supply, and VDDSYN.
- A low voltage band gap generates the reference voltages and currents for voltage regulators and LVDs.
- A Power On Reset (POR) monitor is used to check main regulator supply VDDREG and core supply VDD and guarantees proper system function even at very low voltage supply levels.
- No power sequencing constraint required.
- An independent internal regulator generates 1.2V supply voltage for the low voltage digital portion of the PMC.
- A 5V to 3.3V LDO regulator is enabled when the PMC is in SMPS5V mode and when the PMC is in LDO mode with nominal supply voltage of 5V (LDO5V mode). The LDO 5V to 3V is disabled when VDDREG is 3.3V nominal and in this case VDDREG and VDDSYN must be connected together (LDO3V mode).
- A loose precision temperature sensor detects over-temperature conditions in the PMC and adjacent area. Its low accuracy requires that temperature is checked with the included precision temperature sensor before taking any corrective action.
- Direct measurement of PMC internal voltages is available at predefined ADC channels.

5.1.1.1 Analog PMC_SMPS features

- Embedded voltage regulator (2.7 V up to 5.5 V regulator supply (VDDREG)) controller for generating core VDD voltage. For the correct allowed voltage range refer to *PXR40 Microcontroller Data Sheet*.
- The PMC supports two regulation modes (linear and switch mode), which are controlled by REGSEL pin.
- When VDDREG is above 4.0 V roughly, the 3.3 V internal linear regulator is enabled and regulates the VDDSYN ball to a nominal 3.3 V, sense point is taken on VDD33. VDDSYN and VDD33 must be connected/shorted together with minimum impedance (no resistors or inductors allowed).
- Monitors the following supplies:
 - core voltage pin that connects in the package to core voltage
 - 3.3V via the VDD33 pin (input to the 3.3V network)
 - 5V on VDDREG
- Disabling 3.3 V internal regulator
 - See [Section 5.5.4, 3.3V Internal Voltage Regulator](#). If VDDREG is 5 V, you need to drive VDD33/VDDSYN at 3.5 V +/- 3% and program the PMC to regulate the 3.3 V at minimum voltage by programming the correspondent control nibble to eliminate contention between the two regulators.

5.1.1.2 Digital PMC_SMPS features

Software interfaces for:

- low voltage detects and POR circuits from the PMC analog blocks plus LVD from VDDSYN segment as 3.3V LVD
- low voltage detects for reset segment LVD (VDDEH1)
- POR level of reset pin segment (VDDEH1)
- low voltage detects for other IO segment LVD (VDDEH3, VDDEH4, VDDEH5, VDDEH6, VDDEH7)
- low voltage detect on VDDA (from ADC band gap reference)
- standby regulator brownout circuit

5.1.2 Block Diagram

The [Figure 5-1](#) is the block diagram for the PMC.

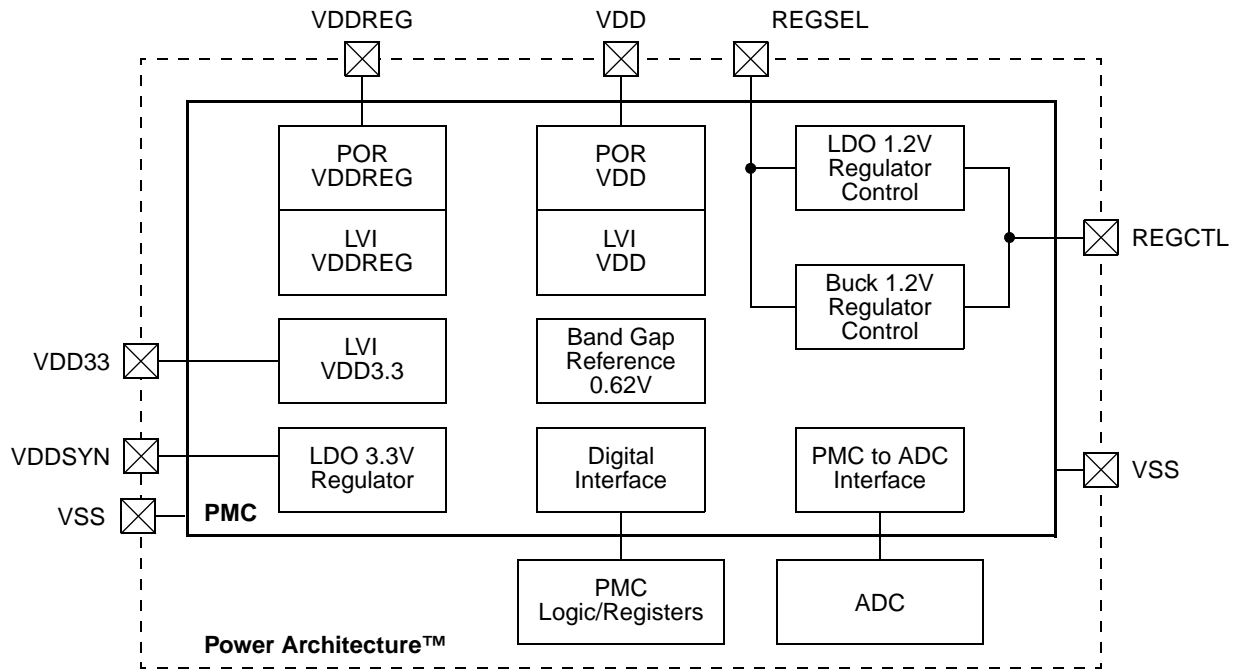

Figure 5-1. Power Management Controller Block Diagram

5.1.3 PMC Operation Modes

There are three modes of operation and relative configuration used at board level to choose which regulators are active from start up on and which levels for LVD should be enforced during operation. PMC operation modes are resumed in [Table 5-1](#).

Table 5-1. PMC Operation Modes

| Short Mode | Full Name | Description |
|------------|--|--|
| LDO3V | 3.3V Voltage Supply, LDO regulator enabled | When external pin REGSEL is connected to VSS -it has a weak internal resistive pull down- and regulator supply voltage is 3.3V nominal, the Linear 1.2V VRC is enabled and the internal 3.3V regulator is disabled with tri-stated output. VDDSYN must be connected to VDDREG. An external ballast transistor is expected on REGCTL as described in 1.2V LDO regulator section. VDDREG LVD selected to 3V nominal. |

Table 5-1. PMC Operation Modes (continued)

| Short Mode | Full Name | Description |
|------------|---|---|
| LDO5V | 5V Voltage Supply, LDO regulator enabled | When external pin REGSEL is connected to VSS -it has a weak internal resistive pull down- and regulator supply voltage is 5V nominal, the Linear 1.2V VRC is enabled, as the internal 3.3V regulator. An external ballast transistor is expected on REGCTL as described in 1.2V LDO regulator section. An external decoupling capacitor is expected on VDDSYN (details in the 3.3V regulator section). VDDREG LVD selected to 3V nominal. |
| SMPS5V | 5V Voltage Supply, SMPS regulator enabled | When external pin REGSEL is connected to VDDREG and regulator supply voltage is 5V nominal, the Switched Mode VRC is enabled, and the internal 3.3V regulator is enabled. An external MOS - Schottky device is expected on REGCTL as described in SMPS regulator section. A decoupling capacitor must be used on VDDSYN (details in the 3.3V regulator section). VDDREG LVD selected to 5V nominal. |

5.2 External Signals Description

5.2.1 Signals Information

The following table describes the PMC signals and their properties (also refer to the Signals chapter).

Table 5-2. PMC Signals

| Pin Name | Type | Nominal Voltage (V) |
|----------|--------|--|
| VDDREG | supply | 3.3 or 5 |
| VSS | supply | ground |
| VDD | supply | 1.2 |
| VDDSYN | supply | 3.3 |
| REGSEL | input | ground or VDDREG |
| REGCTL | output | 0V – 5V PWM signal in SMPS mode About VDD+0.7V in LDO mode. |
| VSS | supply | ground |
| VDD33 | input | 3.3 |

5.3 Signals Details

The following sections detail the signals used by the PMC .

5.3.1 VDDREG

Positive analog power supply for PMC and voltage regulators. It can be nominal 5V or nominal 3.3V. It supplies internal regulators and LVDs.

Voltage range VDDR for 5V operation and VDD33 for 3V operation can be found in the *PXR40 Microcontroller Data Sheet*.

Requires a decoupling cap of 5 – 20 uF between VDDREG and VSS as close as possible to the pins to minimize board parasitics.

5.3.2 VDD

Positive digital power supply for core voltage. Nominal value is 1.2V, voltage range is VDD12. Decoupling capacitance configuration depends on selected regulator (LDO or SMPS). More details available in the correspondent regulator description and in [Section 5.7.2, Hardware Design Recommendations](#).

5.3.3 VDDSYN

Positive 3.3V regulator output - power supply, voltage range VDD33, usually tied flash. Internal regulator is ON in SMPS5V mode or in LDO5V mode. The 3.3V regulator is OFF in LDO3V mode with VDDREG in the 3.3V range. When enabled, the VDDSYN regulator can source up to 80 mA keeping the regulation in the 3.3V range. See the *PXR40 Microcontroller Data Sheet* for more details. Sense voltage is taken at VDD33, hence it is recommended to short VDDSYN and VDD33 with low impedance short track.

When the internal regulator is disabled the pin has a weak 35 k Ω pull down resistor and VDDSYN must be connected to VDDREG. Requires an external capacitor of 200 nF - 4 uF (depending on the application), on the pad or as closest as possible with negative connection to VSS.

5.3.4 VSS

Negative digital power supply.

PMC substrate connection.

5.3.5 REGCTL

VRC 1.2V output that connects to the base of ballast NPN in LDO3V or LDO5V mode, or to the gate of the n-MOS in SMPS5V mode.

5.3.6 REGSEL

Analog input that selects 1.2 VRC operation. It can be connected only to VDDREG or VSS.

When connected to VDDREG it enables the SMPS regulator, and requires a nominal supply voltage of 5V. Else the LDO regulator is enabled and both 3.3V and 5V operation are allowed. A weak 200k Ω pull down resistor keeps the default level at 0V when pin is floating.

5.3.7 VDD33

Sense point for LVD and regulator feedback of the 3.3V VDDSYN analog supply.

Input that produces 3.3V regulator reference and LVD 3.3V reference.

Must be shorted to VDDSYN with low impedance connection.

5.4 Memory Map/Register Definition

Table 5-3 shows the PMC memory map. The PMC memory maps 3 registers for configuring, monitoring, and trimming the LVD monitors.

Table 5-3. Power Management Controller Memory Map

| Address | Register | Bits | Access | Reset Value | Section/Page |
|-------------------|----------------------------------|------|--------|---|--------------|
| PMC_BASE + 0x0000 | PMC_MCR — Configuration register | 32 | R/W | 0x9800_0000 | 5.4.1/5-6 |
| PMC_BASE + 0x0004 | PMC_TRIMR — Trimming register | 32 | R/W | 0x0000_0006 | 5.4.2/5-8 |
| PMC_BASE + 0x0008 | PMC_SR — Status register | 32 | R/W | 0x0200_0000 or 0x0600_0000 ¹ | 5.4.3/5-12 |

¹ Reset value depends on whether RAM standby regulator switch reported a brownout condition.

5.4.1 Configuration Register (PMC_MCR)

The configuration register contains configuration and interrupt enable bits for the LVD monitors.

Refer to Section 5.1.1, Features, for a listing of which VDDEH powers are monitored.

Offset: PMC_BASE + 0x0000

Access: User read/write

| | | | | | | | | | | | | | | | | |
|-------|-------|-------|--------|--------|-------|-------|----|----|-------|-------|--------|--------|-------|-------|----|-----|
| | 0 | 1 | 2 | 3 | 4 | 5 | 6 | 7 | 8 | 9 | 10 | 11 | 12 | 13 | 14 | 15 |
| R | LVRER | LVREH | LVRE50 | LVRE33 | LVREC | LVREA | 0 | 0 | LVIER | LVIEH | LVIE50 | LVIE33 | LVIEC | LVIEA | 0 | TLK |
| W | | | | | | | | | | | | | | | | |
| Reset | 1 | 0 | 0 | 1 | 1 | 0 | 0 | 0 | 0 | 0 | 0 | 0 | 0 | 0 | 0 | 0 |
| | 16 | 17 | 18 | 19 | 20 | 21 | 22 | 23 | 24 | 25 | 26 | 27 | 28 | 29 | 30 | 31 |
| R | 0 | 0 | 0 | 0 | 0 | 0 | 0 | 0 | 0 | 0 | 0 | 0 | 0 | 0 | 0 | 0 |
| W | | | | | | | | | | | | | | | | |
| Reset | 0 | 0 | 0 | 0 | 0 | 0 | 0 | 0 | 0 | 0 | 0 | 0 | 0 | 0 | 0 | 0 |

Figure 5-2. Configuration and Status Register (PMC_MCR)

Table 5-4. PMC_MCR Field Descriptions

| Field | Description |
|-------------|---|
| 0 LVRER | Reset-pin-supply low-voltage reset enable. This bit defines whether an LVD assertion on the supply of the I/O segment that contains the reset pin will generate system reset or not. 0 Disabled. LVD assertion on the supply of the I/O segment that contains the reset pin does not cause system reset. 1 Enabled. LVD assertion on the supply of the I/O segment that contains the reset pin causes system reset. |
| 1 LVREH | VDDEH low-voltage reset enable. This bit defines whether an LVD assertion on any monitored VDDEH supply will generate system reset or not. 0 Disabled. LVD assertion on any monitored VDDEH supply does not cause system reset. 1 Enabled. LVD assertion on any monitored VDDEH supply causes system reset. |
| 2 LVRE50 | VDDREG low-voltage reset enable. This bit defines whether an LVD assertion on the VDDREG supply of the voltage regulator will generate system reset or not. 0 Disabled. LVD assertion on the VDDREG supply of the voltage regulator does not cause system reset. 1 Enabled. LVD assertion on the VDDREG supply of the voltage regulator causes system reset. |

Table 5-4. PMC_MCR Field Descriptions (continued)

| Field | Description |
|--------------|--|
| 3 LVRE33 | VDDSYN low-voltage reset enable. This bit defines whether an LVD assertion on the VDDSYN supply will generate system reset or not. 0 Disabled. LVD assertion on the VDDSYN supply does not cause system reset. 1 Enabled. LVD assertion on the VDDSYN supply causes system reset. |
| 4 LVREC | Core-voltage-supply VDD low-voltage reset enable. This bit defines whether an LVD assertion on the core voltage VDD supply will generate system reset or not. 0 Disabled. LVD assertion on the core voltage supply does not cause system reset. 1 Enabled. LVD assertion on the core voltage supply causes system reset. |
| 5 LVREA | VDDA low-voltage reset enable. This bit defines whether an LVD assertion on the analog power input VDDA1 will generate system reset or not. 0 Disabled. LVD assertion on the analog power input VDDA1 does not cause system reset. 1 Enabled. LVD assertion on the analog power input VDDA1 causes system reset. |
| 6–7 | Reserved |
| 8 LVIER | Reset-pin-supply low-voltage interrupt enable. This bit enables the generation of the low-voltage interrupt request when the supply of the I/O segment that contains the reset pin falls below the corresponding LVD threshold. The low-voltage interrupt is independent from low-voltage reset. If both, interrupt and reset, are enabled, then reset and interrupt will be generated, but reset will then clear the interrupt. 0 Disabled. Low-voltage interrupt request is disabled. 1 Enabled. Low-voltage interrupt request is enabled. |
| 9 LVIEH | VDDEH low-voltage interrupt enable. This bit enables the generation of the low-voltage interrupt request when any monitored VDDEH supply falls below the corresponding LVD threshold. The low-voltage interrupt is independent from low-voltage reset. If both, interrupt and reset, are enabled, then reset and interrupt will be generated, but reset will then clear the interrupt. 0 Disabled. Low-voltage interrupt request is disabled. 1 Enabled. Low-voltage interrupt request is enabled. |
| 10 LVIE50 | VDDREG low-voltage interrupt enable. This bit enables the generation of the low-voltage interrupt request when the VDDREG supply of the voltage regulator falls below the corresponding LVD threshold. The low-voltage interrupt is independent from low-voltage reset. If both, interrupt and reset, are enabled, then reset and interrupt will be generated, but reset will then clear the interrupt. 0 Disabled. Low-voltage interrupt request is disabled. 1 Enabled. Low-voltage interrupt request is enabled. |
| 11 LVIE33 | VDDSYN low-voltage interrupt enable. This bit enables the generation of the low-voltage interrupt request when the VDDSYN power supply gets below the corresponding LVD threshold. The low-voltage interrupt is independent from low-voltage reset. If both, interrupt and reset, are enabled, then reset and interrupt will be generated, but reset will then clear the interrupt. 0 Disabled. Low-voltage interrupt request is disabled. 1 Enabled. Low-voltage interrupt request is enabled. |
| 12 LVIEC | Core-voltage-supply low-voltage VDD interrupt enable. This bit enables the generation of the low-voltage interrupt request when the core voltage supply gets below the corresponding LVD threshold. The low-voltage interrupt is independent from low-voltage reset. If both, interrupt and reset, are enabled, then reset and interrupt will be generated, but reset will then clear the interrupt. 0 Disabled. Low-voltage interrupt request is disabled. 1 Enabled. Low-voltage interrupt request is enabled. |

Table 5-4. PMC_MCR Field Descriptions (continued)

| Field | Description |
|-------------|---|
| 13 LVIEA | VDDA low-voltage interrupt enable. This bit enables the generation of the low-voltage interrupt request when the analog power input VDDA1 falls below the corresponding LVD threshold. The low-voltage interrupt is independent from low-voltage reset. If both, interrupt and reset, are enabled, then reset and interrupt will be generated, but reset will then clear the interrupt. 0 Disabled. Low-voltage interrupt request is disabled. 1 Enabled. Low-voltage interrupt request is enabled. |
| 14 | Reserved |
| 15 TLK | Trimming lock. This is a set-only bit that comes out of reset negated, and can be asserted one time after reset to lock the trimming register. Once asserted, it cannot be negated anymore. When TLK is asserted, the Trimming Register becomes read-only and cannot be changed until the next reset. 0 Trimming register can be written. 1 Trimming register is read-only. |
| 16–31 | Reserved |

5.4.2 Trimming Register (PMC_TRIMR)

The trimming register allows the user to fine tune the voltage of the regulators and the LVD thresholds. It can only be written when the TLK bit of the PMC_MCR is negated. Once TLK has been asserted, this register becomes read-only until the next system reset.

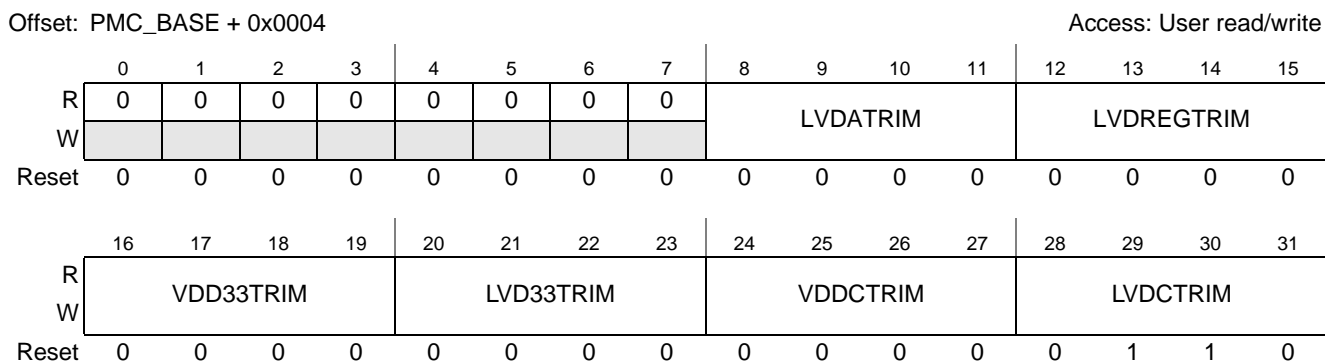

Figure 5-3. Trimming Register (PMC_TRIMR)

Table 5-5. PMC_TRIMR Field Descriptions

| Field | Description |
|-------|-------------|
| 0–7 | Reserved |

Table 5-5. PMC_TRIMR Field Descriptions (continued)

| Field | Description |
|---------------------|--|
| 8–11 LVDATRIM | LVD VDDA trimming. This field is used to fine tune the voltage threshold of the VDDA1 rising LVD, used to monitor the analog power input VDDA1. See the <i>PXR40 Microcontroller Data Sheet</i> for details. 0111 LVDA+160 mV 0110 LVDA+140 mV 0101 LVDA+120 mV 0100 LVDA+100 mV 0011 LVDA+80 mV 0010 LVDA+60 mV 0001 LVDA+40 mV 0000 LVDA+20 mV 1111 Nominal, start-up and default value LVDA 1110 LVDA-20 mV 1101 LVDA-40 mV 1100 LVDA-60 mV 1011 LVDA-80 mV 1010 LVDA-100 mV 1001 LVDA-120 mV 1000 LVDA-140 mV |
| 12–15 LVDREGTRIM | Description: This field is used to fine tune the voltage threshold of LvdReg the rising LVD, used to monitor the VDDREG supply - rising edge. See the <i>PXR40 Microcontroller Data Sheet</i> for details. 0111 LvdReg–8 * LVDSTEPREG 0110 LvdReg–7 * LVDSTEPREG 0101 LvdReg–6 * LVDSTEPREG 0100 LvdReg–5 * LVDSTEPREG 0011 LvdReg–4 * LVDSTEPREG 0010 LvdReg–3 * LVDSTEPREG 0001 LvdReg–2 * LVDSTEPREG 0000 LvdReg–1 * LVDSTEPREG 1111 Nominal, start-up and default value LvdReg 1110 LvdReg + 1 * LVDSTEPREG 1101 LvdReg + 2 * LVDSTEPREG 1100 LvdReg + 3 * LVDSTEPREG 1011 LvdReg + 4 * LVDSTEPREG 1010 LvdReg + 5 * LVDSTEPREG 1001 LvdReg + 6 * LVDSTEPREG 1000 LvdReg + 7 * LVDSTEPREG |

Table 5-5. PMC_TRIMR Field Descriptions (continued)

| Field | Description |
|----------------------------|---|
| <p>16–19 VDD33TRIM</p> | <p>Description: This field is used to fine tune VDD33 the output voltage of the 3.3V regulator, the VDDSYN supply. See the <i>PXR40 Microcontroller Data Sheet</i> for details.</p> <p>0111 VDD33–8 * STEPV33 0110 VDD33–7 * STEPV33 0101 VDD33–6* STEPV33 0100 VDD33–5* STEPV33 0011 VDD33–4* STEPV33 0010 VDD33–3* STEPV33 0001 VDD33–2* STEPV33 0000 VDD33–1* STEPV33 1111 Nominal, start-up and default value VDD33 1110 VDD33+1* STEPV33 1101 VDD33+2* STEPV33 1100 VDD33+3* STEPV33 1011 VDD33+4* STEPV33 1010 VDD33+5* STEPV33 1001 VDD33+6* STEPV33 1000 VDD33+7* STEPV33</p> |
| <p>20–23 LVD33TRIM</p> | <p>Description: LVD 3.3V trimming. This field is used to fine tune the rising voltage threshold of the VDDSYN supply, which can be internally regulated by the 3.3V regulator in LDO5V and SMPS5V modes or can be provided externally in LDO3V mode. See the <i>PXR40 Microcontroller Data Sheet</i> for details.</p> <p>0111 LVD33–8 * LVDSTEP33 0110 LVD33–7 * LVDSTEP33 0101 LVD33–6 * LVDSTEP33 0100 LVD33–5 * LVDSTEP33 0011 LVD33–4 * LVDSTEP33 0010 LVD33–3 * LVDSTEP33 0001 LVD33–2 * LVDSTEP33 0000 LVD33–1 * LVDSTEP33 1111 Nominal, start-up and default value of LVD33 1101 LVD33+1 * LVDSTEP33 1110 LVD33+2 * LVDSTEP33 1100 LVD33+3 * LVDSTEP33 1011 LVD33+4 * LVDSTEP33 1001 LVD33+5 * LVDSTEP33 1010 LVD33+6 * LVDSTEP33 1000 LVD33+7 * LVDSTEP33</p> |

Table 5-5. PMC_TRIMR Field Descriptions (continued)

| Field | Description |
|-------------------|--|
| 24–27 VDDCTRIM | Description: This field is used to fine tune VDD12OUT the output voltage of the 1.2V regulator, correspondent to the VDD supply. See the <i>PXR40 Microcontroller Data Sheet</i> for details. 0111 VDD12OUT–8 * STEPV12 0110 VDD12OUT–7 * STEPV12 0101 VDD12OUT–6 * STEPV12 0100 VDD12OUT–5 * STEPV12 0011 VDD12OUT–4 * STEPV12 0010 VDD12OUT–3 * STEPV12 0001 VDD12OUT–2 * STEPV12 0000 VDD12OUT–1 * STEPV12 1111 Nominal, start-up and default value of VDD12OUT 1110 VDD12OUT+1* STEPV12 1101 VDD12OUT+2* STEPV12 1100 VDD12OUT+3* STEPV12 1011 VDD12OUT+4* STEPV12 1010 VDD12OUT+5* STEPV12 1001 VDD12OUT+6* STEPV12 1000 VDD12OUT+7* STEPV12 |
| 28–31 LVDCTRIM | Description: LVD 1.2V trimming. This field is used to fine tune the rising voltage threshold of the VDD supply. See the <i>PXR40 Microcontroller Data Sheet</i> for details. 0111 LVD12–11 * LVDSTEP12 0110 LVD12–10 * LVDSTEP12 — Start up value 0101 LVD12–9 * LVDSTEP12 0100 LVD12–8 * LVDSTEP12 0011 LVD12–7 * LVDSTEP12 0010 LVD12–6 * LVDSTEP12 0001 LVD12–5 * LVDSTEP12 0000 LVD12–4 * LVDSTEP12 1111 LVD12–3 * LVDSTEP12 1101 LVD12–2 * LVDSTEP12 1110 LVD12–1 * LVDSTEP12 1100 Default LVD12 value to be programmed immediately after reset if core voltage internal regulator is used 1011 LVD12+ 1* LVDSTEP12 1001 LVD12+ 2* LVDSTEP12 1010 LVD12+ 3* LVDSTEP12 1000 LVD12+ 4* LVDSTEP12 |

5.4.3 Status Register (PMC_SR)

The status register contains interrupt flag bits for the LVD monitors.

Offset: PMC_BASE + 0x0008

Access: User read/write

| | | | | | | | | | | | | | | | | |
|-------|---|---|---|---|---|----------------|-------|------|---|---|----|----|----|-----------|----|----|
| | 0 | 1 | 2 | 3 | 4 | 5 | 6 | 7 | 8 | 9 | 10 | 11 | 12 | 13 | 14 | 15 |
| R | 0 | 0 | 0 | 0 | 0 | LVF STBY | BGRDY | BGTS | 0 | 0 | 0 | 0 | 0 | LVFC STBY | 0 | 0 |
| W | | | | | | | | | | | | | | w1c | | |
| Reset | 0 | 0 | 0 | 0 | 0 | u ¹ | | 0 | 0 | 0 | 0 | 0 | 0 | 0 | 0 | 0 |

| | | | | | | | | | | | | | | | | |
|-------|-------|-------|---------|---------|-------|-------|----|----|------|------|--------|--------|------|------|----|----|
| | 16 | 17 | 18 | 19 | 20 | 21 | 22 | 23 | 24 | 25 | 26 | 27 | 28 | 29 | 30 | 31 |
| R | LVFCR | LVFCH | LVFC 50 | LVFC 33 | LVFCC | LVFCA | 0 | 0 | LVFR | LVFH | LVF 50 | LVF 33 | LVFC | LVFA | 0 | 0 |
| W | w1c | w1c | w1c | w1c | w1c | w1c | | | | | | | | | | |
| Reset | 0 | 0 | 0 | 0 | 0 | 0 | 0 | 0 | 0 | 0 | 0 | 0 | 0 | 0 | 0 | 0 |

Figure 5-4. Status Register (PMC_SR)

¹ Reset value depends on whether RAM standby regulator switch reported a brownout condition.

Table 5-6. PMC_SR Field Descriptions

| Field | Description |
|----------------|---|
| 0–4 | Reserved |
| 5 LVFSTBY | Standby-RAM-supply low-voltage flag. This read-only bit indicates that a brownout condition was reported by the RAM standby regulator switch. Software can clear this bit by writing '1' to the LVFCSTBY bit. 0 No occurrence. 1 LVD occurrence, or brownout, reported by the RAM standby regulator switch. |
| 6 BGRDY | Bandgap ready. This read-only bit gets asserted when the PMC bandgap circuit has finished its startup procedure during power-up. The PMC LVDs are disabled (output negated) while BGRDY is negated. 0 Bandgap not ready. PMC LVDs disabled. 1 Bandgap ready. PMC LVDs enabled. |
| 7 BGTS | Bandgap temperature status. This read-only bit stores bandgap temperature status. 0 Temperature out of range. Above 160 C. 1 Temperature in range. Below 160 C. |
| 8–12 | Reserved |
| 13 LVFCSTBY | Standby-RAM-supply LVF clear. This write-only bit is used to clear the low-voltage flag reported by the RAM standby regulator switch. Writing 1 to this bit informs the RAM standby regulator switch to clear LVFSTBY. Writing 0 has no effect. Reading this bit always returns 0. 0 No effect. 1 Clears LVFSTBY. |
| 14–15 | Reserved |
| 16 LVFCR | Reset-pin-supply LVF clear. This write-only bit is used to clear the low-voltage flag associated with the supply of the I/O segment that contains the reset pin. Writing 1 to this bit clears LVFR. Writing 0 has no effect. Reading this bit always returns 0. 0 No effect. 1 Clears LVFR. |

Table 5-6. PMC_SR Field Descriptions (continued)

| Field | Description |
|--------------|--|
| 17 LVFCH | VDDEH LVF clear. This write-only bit is used to clear the low-voltage flag associated with the monitored VDDEH supplies. Writing 1 to this bit clears LVFH. Writing 0 has no effect. Reading this bit always return 0. 0 No effect. 1 Clears LVFH. |
| 18 LVFC50 | VDDREG LVF clear. This write-only bit is used to clear the low-voltage flag associated with the VDDREG voltage regulator supply. Writing 1 to this bit clears LVF50. Writing 0 has no effect. Reading this bit always returns 0. 0 No effect. 1 Clears LVF50. |
| 19 LVFC33 | VDDSYN LVF clear. This write-only bit is used to clear the low-voltage flag associated with the VDDSYN 3.3 V supply. Writing 1 to this bit clears LVF33. Writing 0 has no effect. Reading this bit always returns 0. 0 No effect. 1 Clears LVF33. |
| 20 LVFCC | Core-voltage-supply LVF clear. This write-only bit is used to clear the low-voltage flag associated with the core voltage supply. Writing 1 to this bit clears LVFC. Writing 0 has no effect. Reading this bit always returns 0. 0 No effect. 1 Clears LVFC. |
| 21 LVFCA | VDDA LVF clear. This write-only bit is used to clear the low-voltage flag associated with the analog power input VDDA1. Writing 1 to this bit clears LVFA. Writing 0 has no effect. Reading this bit always return 0. 0 No effect. 1 Clears LVFA. |
| 22–23 | Reserved |
| 24 LVFR | Reset-pin-supply low-voltage flag. This read-only bit is the low-voltage flag associated with the supply of the I/O segment that contains the reset pin. It is asserted when the supply falls below the corresponding LVD threshold, and can be cleared by the CPU by writing 1 to the LVFCR bit. If the LVIER bit is also asserted, a low-voltage interrupt is sent to the CPU. If LVRER is also asserted, a system reset will be generated, which will clear LVFR and negate the interrupt request. 0 No occurrence. 1 LVD occurrence detected on the supply of the I/O segment that contains the reset pin. |
| 25 LVFH | VDDEH low-voltage flag. This read-only bit is the low-voltage flag associated with the monitored VDDEH supplies. It is asserted when any monitored VDDEH supply falls below its corresponding LVD threshold, and can be cleared by the CPU by writing 1 to the LVFCH bit. If the LVIEH bit is also asserted, a low-voltage interrupt is sent to the CPU. If LVREH is also asserted, a system reset will be generated, which will clear LVFH and negate the interrupt request. 0 No occurrence. 1 LVD occurrence detected on a monitored VDDEH supply. |
| 26 LVF50 | VDDREG low-voltage flag. This read-only bit is the low-voltage flag associated with the VDDREG supply of the voltage regulator. It can be cleared by the CPU by writing 1 to the LVFC50 bit. If the LVIE5 bit is also asserted, a low-voltage interrupt is sent to the CPU. If LVRE50 is also asserted, a system reset will be generated, which will clear LVF50 and negate the interrupt request. 0 No occurrence. 1 LVD occurrence detected on the VDDREG supply of the voltage regulator. |

Table 5-6. PMC_SR Field Descriptions (continued)

| Field | Description |
|-------------|--|
| 27 LVF33 | VDDSYN low-voltage flag. This read-only bit is the low-voltage flag associated with the VDDSYN 3.3 V supply. It is asserted when the 3.3 V supply falls below the corresponding LVD threshold, and can be cleared by the CPU by writing 1 to the LVFC33 bit. If the LVIE33 bit is also asserted, a low-voltage interrupt is sent to the CPU. If LVRE33 is also asserted, a system reset will be generated, which will clear LVF33 and negate the interrupt request. 0 No occurrence. 1 LVD occurrence detected on the 3.3V supply. |
| 28 LVFC | Core-voltage-supply low-voltage flag. This read-only bit is the low-voltage flag associated with the core voltage supply. It is asserted when the core voltage supply falls below the corresponding LVD threshold, and can be cleared by the CPU by writing 1 to the LVFCC bit. If the LVIEC bit is also asserted, a low-voltage interrupt is sent to the CPU. If LVREC is also asserted, a system reset will be generated, which will clear LVFC and negate the interrupt request. 0 No occurrence. 1 LVD occurrence detected on the core voltage supply. |
| 29 LVFA | VDDA low-voltage flag. This read-only bit is the low-voltage flag associated with the analog power input VDDA1. It is asserted when the VDDA1 supply falls below its corresponding LVD threshold, and can be cleared by the CPU by writing 1 to the LVFCA bit. If the LVIEA bit is also asserted, a low-voltage interrupt is sent to the CPU. If LVREA is also asserted, a system reset will be generated, which will clear LVFA and negate the interrupt request. 0 No occurrence. 1 LVD occurrence detected on the VDDA1 supply. |
| 30–31 | Reserved |

5.5 Functional Description

See [Figure 5-1](#) for a block diagram of the PMC block. Its main building blocks are

- a precision bandgap voltage
- Power On Reset and Low Voltage Detector on VDDREG regulator supply
- a voltage regulator controller with a linear Low Drop Out and a Switched Mode Power Supply options selectable via the REGSEL control
- POR and LVD on VDD digital core supply
- a 3.3V LDO regulator, with its relative 3.3V LVD
- a digital interface to core logic
- an interface between measurable PMC internal signals to the ADC

A start-up sequence has been implemented aiming at improved predictability of PMC behavior. A loose tolerance POR keeps the device in reset until the VDDREG rises above the minimum required voltage for the internal bandgap to come up. When POR clears and the band gap reference is stable, the LVDs are enabled. A dedicated circuit is used to keep LVDs set until current and voltage references are stable and the real LVDs' values are valid.

When the references are stable, the voltage regulator (selected by the pin REGSEL) enters in soft start mode and rises in a controlled fashion the 1.2V regulated voltage supply VDD. As both target regulated voltage VDD12OUT and LVD level LVD12 rely on bandgap voltage, an equivalent variation is to be

expected in absolute LVD trip points and voltage regulator output, so the system shall come up correctly in any condition.

If an external regulator is used to generate the supply voltage, the allowed nominal range is VDD12, but the start up value must be higher than the maximum LVD threshold LVD12 to clear POR and LVD flags and exit the reset state.

All LVDs force reset at start-up. As soon as all of them are cleared, the trimming register can be loaded from flash into the band gap. The low variation of band gap reference voltage after trim, reported in the *PXR40 Microcontroller Data Sheet*, allows the system to achieve high precision regulator target voltage output (not considering transient effects on regulator loads) and LVD trip points.

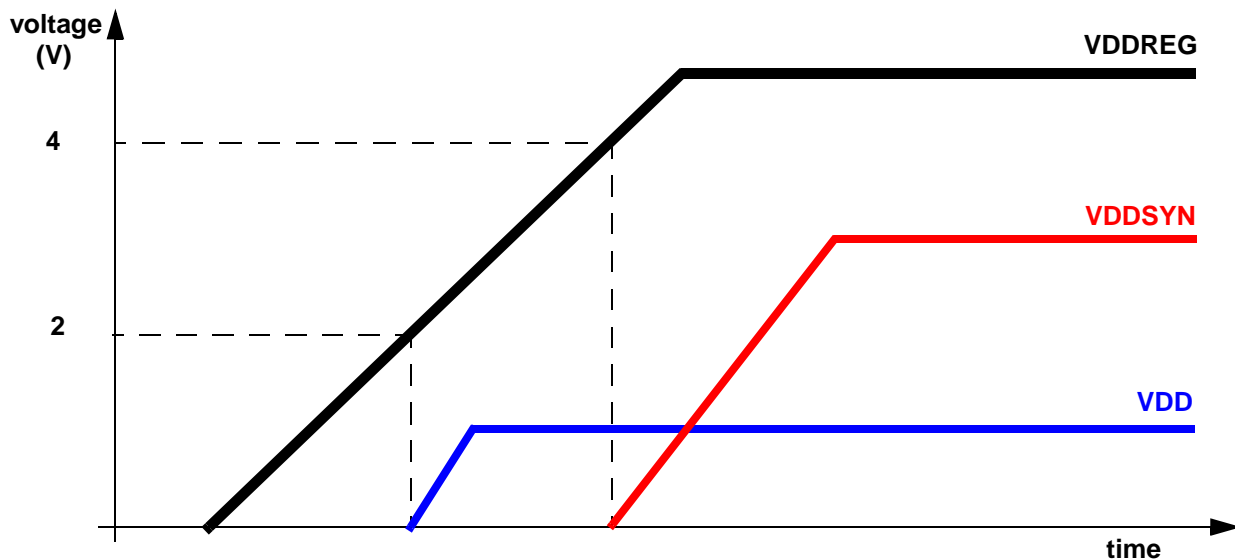

Figure 5-5. PMC internal regulators nominal start-up sequence, rising slope may vary

5.5.1 PMC Internal 1.2V Voltage Regulator Selection

The PMC features two main regulators for core supply voltage VDD. The selection is done at board level by connecting the REGSEL to VDDREG or VSS.

A linear Low Drop Out regulator controller is selected when the pin REGSEL is connected to VSS, otherwise an asynchronous buck switched mode regulator controller is selected when the pin is connected to VDDREG. Do not change REGSEL pin voltage when the device is powered by any supply.

The allowed voltage range of the PMC supply VDDREG is reported in the *PXR40 Microcontroller Data Sheet* under the VDDR symbol. Specifically, when the switched mode supply is chosen (SMPS5V mode) the nominal supply voltage expected is 5 V. Nominal voltage values of 3V and 5V are allowed in LDO3V and LDO5V, respectively. This is because in the LDO3V mode, VDDSYN/VDD33 are supplied to the SOC from external source; whereas in the LDO5V mode, VDDSYN is connected back to VDD33.

When the LDO regulator is selected in LDO3V or LDO5V mode both nominal 5.0 V and 3.3 V are allowed.

A weak pull down of about 100 k Ω is added to ensure the selection of the LDO regulator even when the signal REGSEL is not connected at board level.

5.5.2 PMC Bandgap

An accurate band gap voltage is used in the PMC as reference for regulators and LVDs. Target band gap voltage VBG is 0.62V with variation defined in *PXR40 Microcontroller Data Sheet*.

During factory test, the bandgap is calibrated in curvature and absolute value, in order to achieve a good accuracy over temperature range and supply voltage variation.

5.5.3 VDDREG LVD

A user programmable low voltage detector (LVD) monitors the PMC main supply voltage VDDREG.

When LDO regulator is selected, with respective selection pin REGSEL, the LVD threshold is for a nominal 3.3V supply (both LDO3V and LDO5V modes), else when the SMPS regulator is selected the LVD threshold is nominal 5.0V (SMPS5V mode).

Rising LVD threshold voltage is documented under LvdReg symbol in the *PXR40 Microcontroller Data Sheet*.

The assertion and negation voltages are adjustable via software by writing to the LVDREGTRIM field of the PMC_TRIMR register, which selects one of the 16 voltages available through the appropriate tapped output. The reset and default value of the 4-bit register is “1111”, corresponding to the nominal LvdReg voltage.

LVD scaled voltage can be measured via ADC by selecting the respective channel reported in [Table 5-8](#). During this measurement, the output of the LVD is temporarily forced to low level so that false events, which may be caused by ADC reading, are discarded.

5.5.4 3.3V Internal Voltage Regulator

A 3.3V internal voltage regulator is available and it can supply a total DC current of IDD33 with a maximum load frequency of 10 kHz. The board should be designed to dump all current overshoots and undershoots, by having the VDDSYN pin connected to decoupling capacitors. The recommended external capacitor range may vary between 220 nF and 2.2 μ F with ESR < 100 m Ω .

This regulator is always enabled when supply voltage VDDREG is in the VDDR 5V nominal range. When the supply voltage is in the VDDR 3V nominal range the regulator is automatically turned off, so that an external supply can be applied. In this case VDDREG and VDDSYN must be connected to the same supply voltage with a maximum voltage difference of 200mV.

The regulator can be disabled, so that an external 3.3 V supply can be used (see [Section 5.1.1, Features](#)). In this case it is recommended that the supplied 3.3V is nominal 3.5V +/- 3% during start up when both regulators may be enabled. For the correct operation of the device the externally supplied VDD33 voltage must be higher than the maximum correspondent LVD rising voltage LVD33.

The bond diagram and over voltage protection is shown in Figure 5-6. Core LVD and flash supply are provided by pad VDD33, which is also the default feedback signal for the 3.3V regulator loop. A high voltage detect comparator switches the feedback point from VDD33 to the regulator output VDDSYN in the event that this node raises above its maximum rating value, forcing the regulator to correct its DC point. This feature protects the circuitry connected to the internal 3.3V supply in any event which disconnects VDD33 and VDDSYN (e.g. a board failure or a bond wire failure).

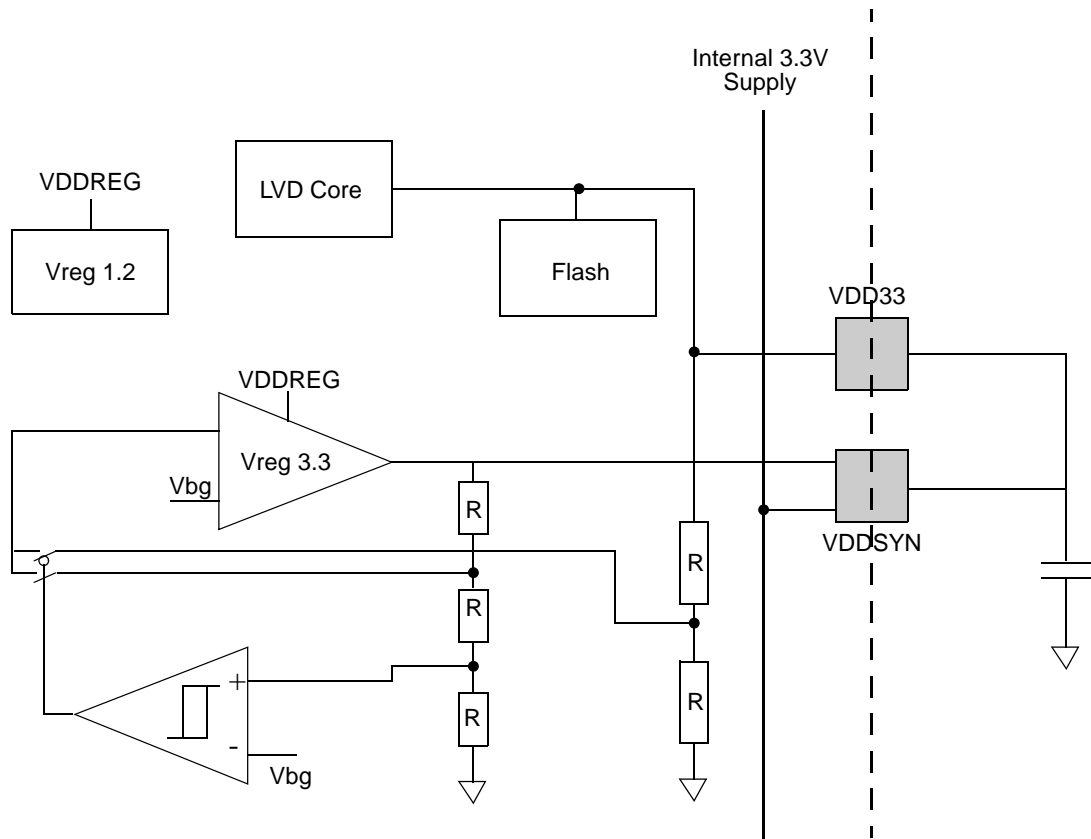

Figure 5-6. 3.3V Regulator power connection

Tolerance of the 3.3V regulator, reported in the *PXR40 Microcontroller Data Sheet*, assumes appropriate decoupling capacitance on VDDSYN pin, maximum current load less than or equal to $IDD33$, and a correct board layout with reduced parasitics. It excludes line and load variation above 10 kHz.

The regulator output voltage, VDD33OUT, is adjustable via software by writing to the field VDD33TRIM of the correspondent trimming register PMC_TRIMR, which selects one of the 16 voltages spaced at STEPV33 step and available through the relative resistor chain. The reset value of the 4-bit register is “1111”.

5.5.5 3.3V VDDSYN LVD

A user programmable low voltage detector (LVD) monitors the voltage VDDSYN.

Rising LVD threshold voltage is documented under LVD33 symbol in the *PXR40 Microcontroller Data Sheet*.

The assertion and negation voltages are adjustable via software by writing to the LVD33TRIM field of the PMC_TRIMR register, which selects one of the 16 voltages available through the appropriate tapped output. The reset and default value of the 4-bit register is “1111”, corresponding to the nominal LVD33 voltage.

LVD scaled voltage can be measured via ADC by selecting the respective channel reported in [Table 5-8](#). During this measurement, the output of the LVD is temporarily forced to low level so that false events, which may be caused by ADC reading, are discarded.

5.5.6 1.2V Voltage Regulator Controller

A double Voltage Regulator Controller (VRC) is implemented in this power management system. It is composed of a linear LDO VRC, and an SMPS VRC. A soft startup block slews the output voltage of the regulator output smoothly in order to avoid ringing or over voltage condition and steep voltage and current slopes. A block diagram of the regulator is shown in [Figure 5-7](#).

The LDO Voltage Regulator Controller is designed to drive an external bipolar transistor and relative decoupling capacitance at bipolar emitter. A smaller compensation capacitor might be required on REGCTL, depending on the external bipolar selected.

The switched controller is a full analog asynchronous regulator, with ramp compensation and equalized error integration. It is used to drive an external high side n-MOS driver / Schottky diode. The regulator output voltage is adjustable using software, to permit the device to center the supply for maximum transient margin.

The feedback of the regulation loop comes from the VDD core voltage through a trimmable resistive divider. By adjusting the trimming control 4-bit word VDDCTRIM it is possible to adjust the regulator target DC output voltage VDD12OUT during device operation, with 16 voltage steps of size STEPV12, around the typical regulator target voltage. The reset value, start up and default condition of the 4-bit register is “1111”.

Tolerance of the 1.2V regulators, reported in the *PXR40 Microcontroller Data Sheet*, assumes appropriate external active and passive devices as reported in bill of materials [Section 5.7.2, Hardware Design Recommendations](#), maximum current load less than or equal to **I_{dd12}**, and a correct board layout with reduced parasitics. It excludes line and load variation above 10 kHz.

The 1.2V supply is internally connected to an ADC channel so that the actual voltage may be read by the microcontroller.

The suitable external driver has an automotive range temperature profile and

- In case of NPN device a minimum beta of 50, maximum current rating >1.5A;
- In case of high side driver maximum threshold voltage of 1.5V, gate capacitance less than 5nF, maximum current rating >2A.

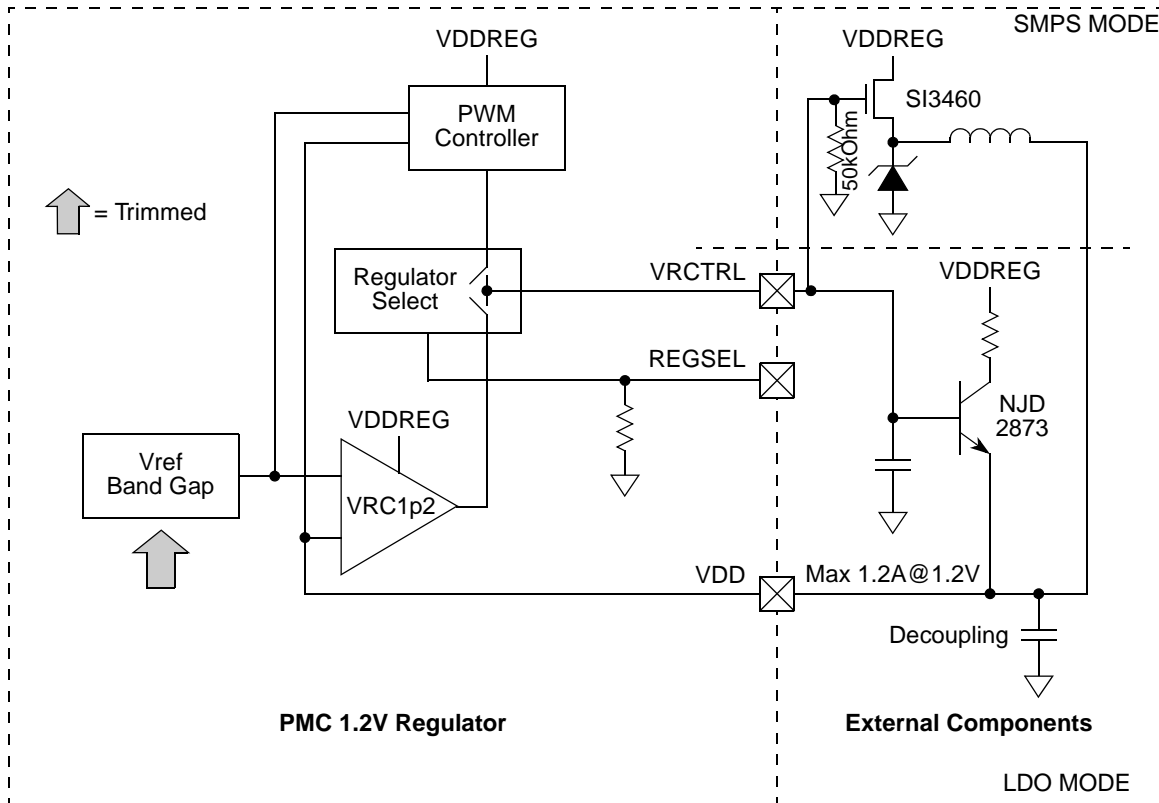

Figure 5-7. Internal Regulator 1.2V LDO and SMPS diagram

5.5.7 1.2V VDD LVD

A user programmable low voltage detector (LVD) monitors the core supply voltage VDD.

Rising LVD threshold voltage is documented under LVD12 symbol in the *PXR40 Microcontroller Data Sheet*.

The assertion and negation voltages are adjustable via software by writing to the LVDCTRIM field of the PMC_TRIMR register, which selects one of the 16 voltages available through the appropriate tapped output. The reset value of the 4-bit register is “0110”, corresponding to the nominal LVD12 voltage.

When an internal regulator (SMPS or LDO) is used to generate the core voltage supply, it is required to change the field of the register to “1100” before increasing core logic clock frequency.

LVD scaled voltage can be measured via ADC by selecting the respective channel reported in [Table 5-8](#). During this measurement, the output of the LVD is temporarily forced to low level so that false events, which may be caused by ADC reading, are discarded.

5.5.8 Trimming

During Power Up and Reset, the BandGap is untrimmed. This allows the MCU to come out of reset.

At the end of the Reset sequence, the BandGap is trimmed by the PMC. This trimming controls the BandGap voltage, which is used as the reference for the Internal Regulators and LVD.

The BandGap Trim values are not visible and they cannot be altered or overwritten by the user.

The levels of the internal regulators and LVD, though, can be adjusted by the user by programming the Trim Registers. This allows the user to control the internal regulator or LVD level within a range of +/- 8 steps from the default value. This is described in [Section 5.4.2, Trimming Register \(PMC_TRIMR\)](#).

5.5.9 Interrupts

The PMC generates one interrupt request signal for each LVD source: VDDREG LVD, VDDSYN LVD, VDD LVD, and VDDA1 LVD. The module also generates combined interrupt request signal which is asserted whenever any of the individual interrupt request signals becomes asserted.

5.5.10 PMC Power-on Reset

A Power-on reset (POR) circuit monitors its supply voltage, providing a logic reset in a guaranteed low voltage range.

Power-on reset will assert as soon as possible after the voltage levels of the POR power supplies begin to rise. Each POR will negate before its power supply rises into the specified range. The behavior for each POR during power supply ramping is shown in [Figure 5-8](#).

Power-on reset (POR) circuits are present at the following power supplies:

- 5V supply of the PMC block and bandgap (VDDREG)
- 1.2V core supply VDD

The POR can be used to prevent critical circuit-like band gap reference or LVDs to operate when the supply voltage is too low (output signals are out of specification). POR trip voltage tracks with technology variations and it should be such that all circuits, that are disabled by its output, can at least work with supplies down to POR level.

The dependence between POR and LVD on VDDREG is summarized in [Figure 5-9](#). As shown, the LVD will reach a consistent state before the POR actually releases the reset, avoiding false startup condition.

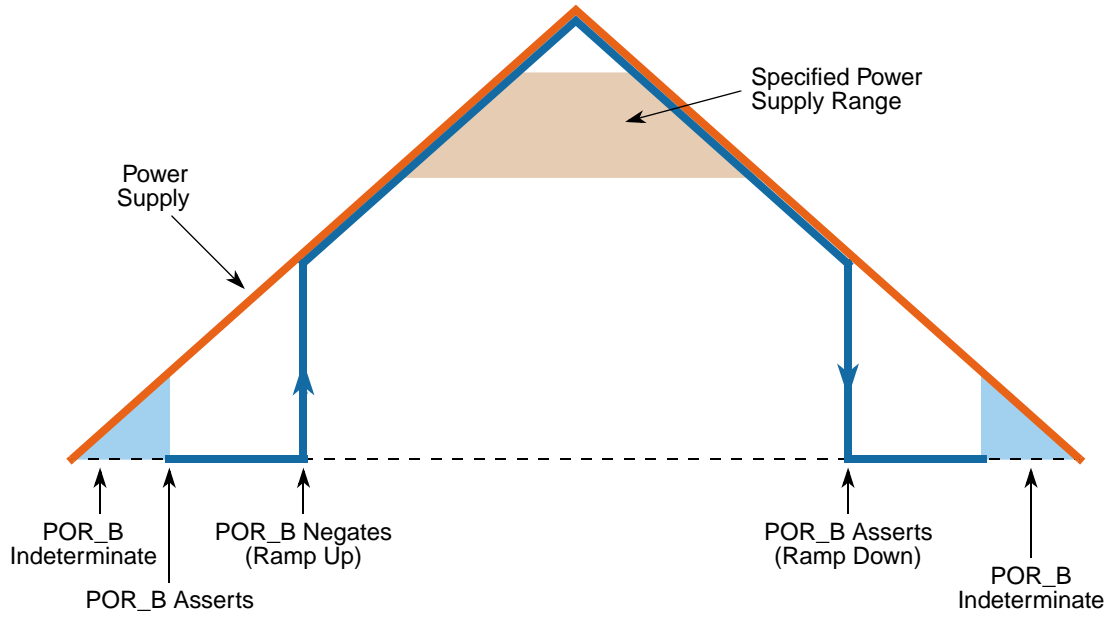

Figure 5-8. POR rising and falling edges

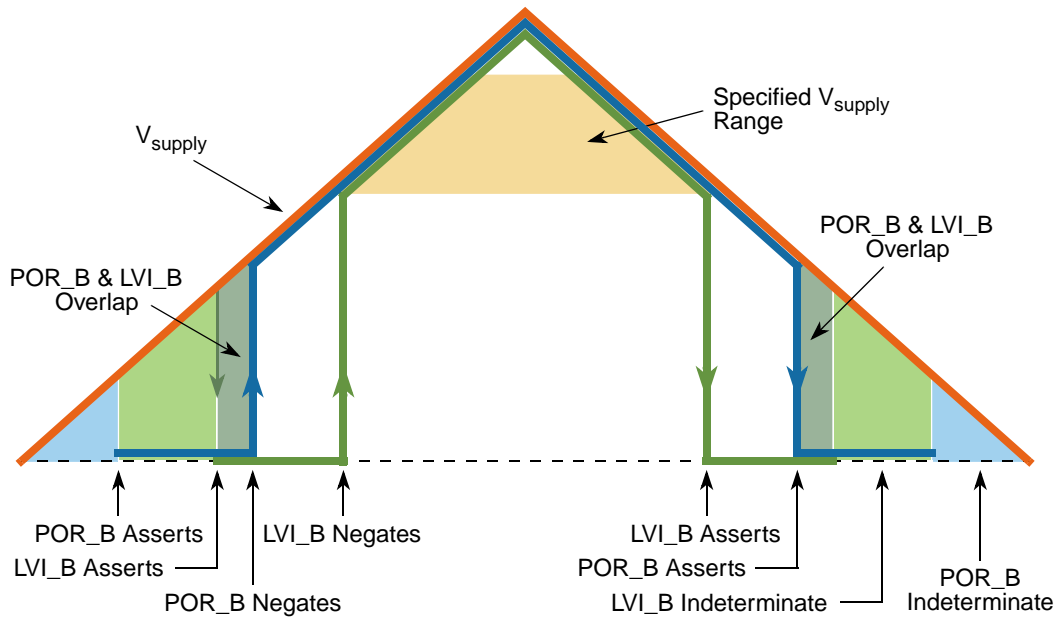

Figure 5-9. POR and LVD rising and falling edges

Table 5-7. POR and LVDs that Gate MCU Reset

| Type | Supply | Description |
|------|------------|---|
| POR | VDDREG | 5V supply of the PMC block and bandgap (VDDREG) |
| POR | VDD | 1.2V core supply VDD |
| LVD | VDD LVD | Core-voltage-supply VDD low-voltage |
| LVD | VDDSYN LVD | VDDSYN low voltage |
| LVD | Reset LVD | Reset-pin-supply low-voltage |

5.5.11 ADC Test Mux

During PMC functional mode it is possible to perform direct measurements through the ADC. PMC internal voltages are routed to the ADC. Each signal can be measured with ADC running at full speed.

Table 5-8. ADC test mux channel for internal PMC signals

| eQADC_A channel number | Signal propagated to ADC | Typical value (approximated) |
|------------------------|--------------------------|---|
| ADC0 CH145 | Band gap 0.62V | 0.62V (trimmed) |
| ADC0 CH146 | Analog supply 1.2V | 1.22V |
| ADC0 CH147 | VDD12OUT | Equal to VDD12OUT / 2.045 |
| ADC0 CH180 | LVD 1.2V | Equal to VLVD12 / 1.774 |
| ADC0 CH181 | VDD33OUT | Equal to VDD33OUT / 5.460 |
| ADC0 CH182 | LVD 3.3V | Equal to VLVD33 / 4.758 |
| ADC0 CH183 | LVD 5.0V | Equal to VLVDREG / 4.758 in LDO mode; (VLVDREG / 7.032 in SMPS mode) |
| ADC1 CH196 | LVD VDDA | Equal to VDDA LVD / 3.8934 |

Regulator feedback and LVD threshold signals propagated to ADC are a scaled down version of the correspondent supply, by means of a resistive divider with programmable steps. The scaled signal read by the ADC V_{scaled} will be approximately equal to the supply voltage V_{supply} divided by the target voltage (LVD or regulator output) V_{target} and multiplied by the band gap reference V_{bg} :

$$V_{scaled} = V_{supply} * V_{bg} / V_{target} \quad \text{Eqn. 5-1}$$

By measuring with ADC scaled supply voltage, supply voltage and bandgap voltage, it is possible to calculate the approximate target LVD or regulator value. V_{target} is equal to: $V_{target} = V_{supply} * V_{bg} / V_{adc}$.

During LVD measurement, the continuous time monitoring is temporarily disabled as the multiplexer toggling could induce a false detection.

5.6 Initialization

The PMC module requires that its main supply voltage, VDDREG, rises above the POR level, so that the band gap reference voltage can be enabled.

After the band gap has come up and stabilized, the 1.2V regulator soft start and optionally the 3.3V regulator soft start begin.

When the internal regulator is used to generate 1.2V core supply, it is required to write “1100” to the LVDCTRIM field before clock frequency is increased.

5.7 Application Information

5.7.1 Regulator Example

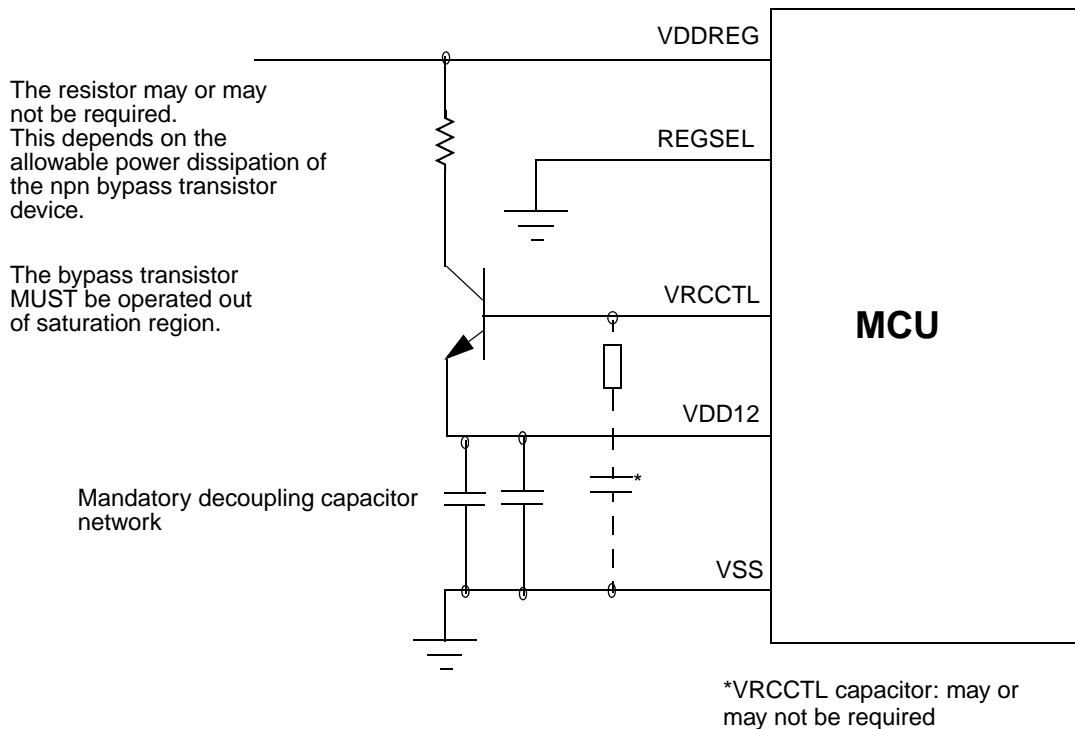

Figure 5-10. VRC 1.2V LDO configuration with external bipolar

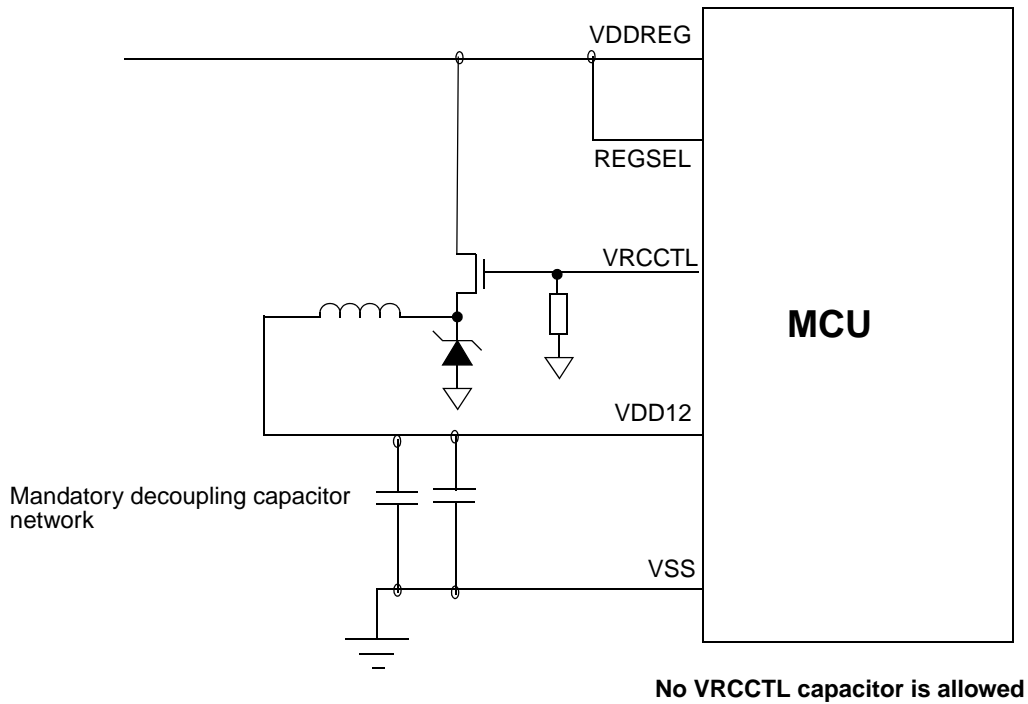

Figure 5-11. VRC 1.2V buck SMPS LDO configuration with external MOS - Schottky diode

5.7.2 Hardware Design Recommendations

Table 5-10. VRC LDO recommended external devices

| Part Name | Part Type | Nominal | Description |
|-----------|-----------|---------------|--|
| BCP68T1 | npn | | ON Semiconductor™ |
| NJD2874 | npn | | ON Semiconductor™ |
| 3BCP68 | npn | | NXP Semiconductors™ |
| | capacitor | 6 x 4.7µF–20V | Ceramic low ESR -One for each VDD pin |
| | capacitor | 6 x 0.1µF–20V | Ceramic -One capacitor for each VDD pin |
| | capacitor | 20µF | Supply decoupling cap (close to bipolar collector) |
| | capacitor | 2.2µF | Snubber cap, required with NJD2874 (on bipolar base) |
| | resistor | 12 Ohm | ESR for snubber cap |

Table 5-11. VRC SMPS recommended external devices

| Part Name | Part Type | Nominal | Description |
|----------------|--------------------|------------------|---|
| IR7353 | HS nMOS + Schottky | | Low threshold n-MOS / Low Vf Schottky diode |
| SS8P3L | Schottky | | Low Vf Schottky diode |
| SI3460f | nMOS | | Low threshold n-MOS |
| LQH66SN2R2M03 | inductor | 2.2 μ H–3.2A | muRata™ unshielded or shielded coil |
| C3225X7R1E106M | capacitor | 2X10uF - 25V | TDK high capacitance ceramic SMD (on VDD close to coil) |
| C3225X7R1E225K | capacitor | 2x2.2uF - 25V | TDK ceramic SMD (on VDD close to MCU) |
| | capacitor | 6 x 0.1uF - 20V | Ceramic -One capacitor for each VDD pin |
| C3225X7R1E106M | capacitor | 2X10uF - 25V | Supply decoupling cap - close to n-MOS drain |
| | resistor | 20 kOhm | Pull down for power n-MOS gate |



Chapter 6

Frequency Modulated Phase-Locked Loop (FMPLL)

6.1 Introduction

The frequency modulated phase-locked loop (FMPLL) module is a frequency modulated phase-locked loop that has been optimized to generate voltage controlled oscillator (VCO) frequencies from 192 MHz – 600 MHz based on an input clock range of 8 MHz to 40 MHz. The frequency multiplication, output dividers and the frequency modulation waveform are register-programmable through a peripheral bus interface.

Figure 6-1 shows the operating frequency domains of the various blocks on this device.

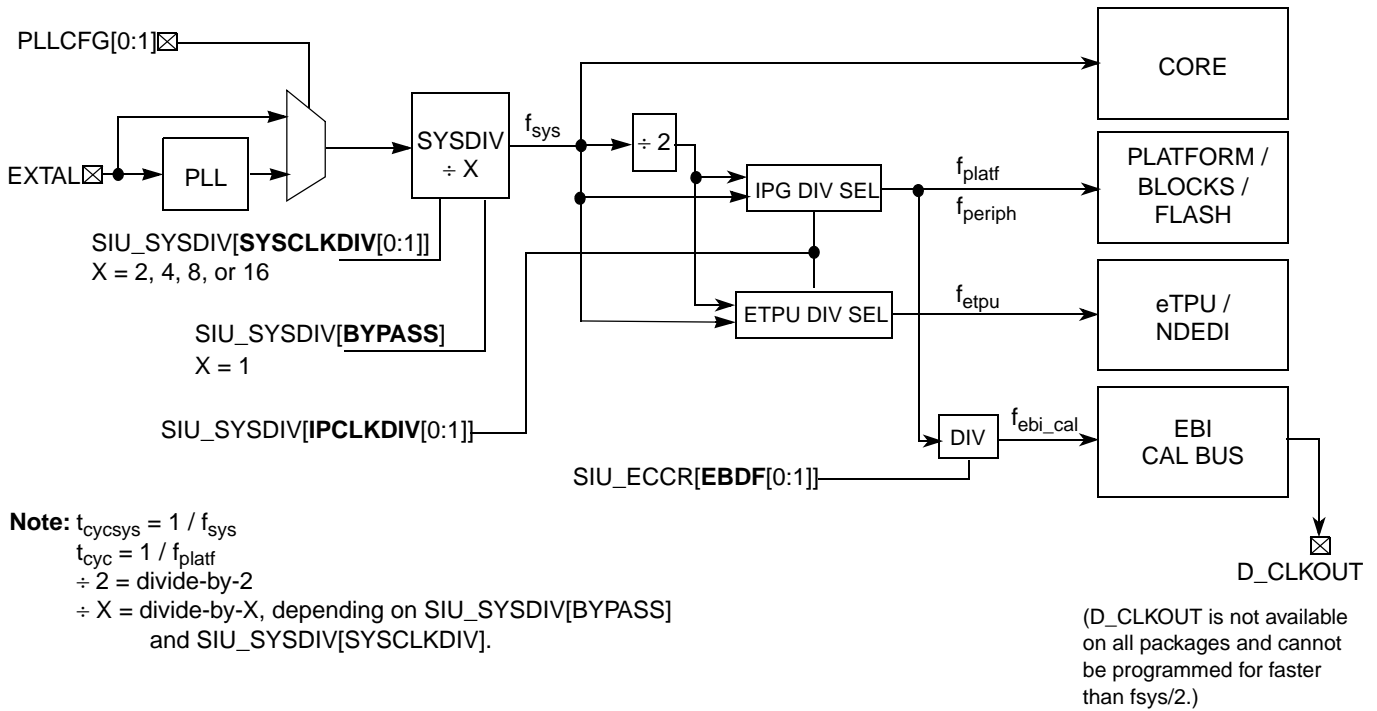

Figure 6-1. PXR40 Block Operating Frequency Domain Diagram

For register and bit descriptions, see:

- [Section 7.3.1.27, System Clock Register \(SIU_SYSDIV\)](#)
- [Section 7.3.1.24, External Clock Control Register \(SIU_ECCR\)](#)

6.1.1 Block Diagram

A simplified block diagram of the FMPLL illustrates the functionality and interdependence of major blocks (see [Figure 6-2](#)). Shaded blocks represent analog circuit components that make up the core analog portion of the FMPLL. The complete FMPLL closed-loop system contains the feedback divider (EMFD) and output divider (ERFD). Refer to [Section 6.4.3.3, PLL Normal Mode Without FM](#), for details on each sub-block.

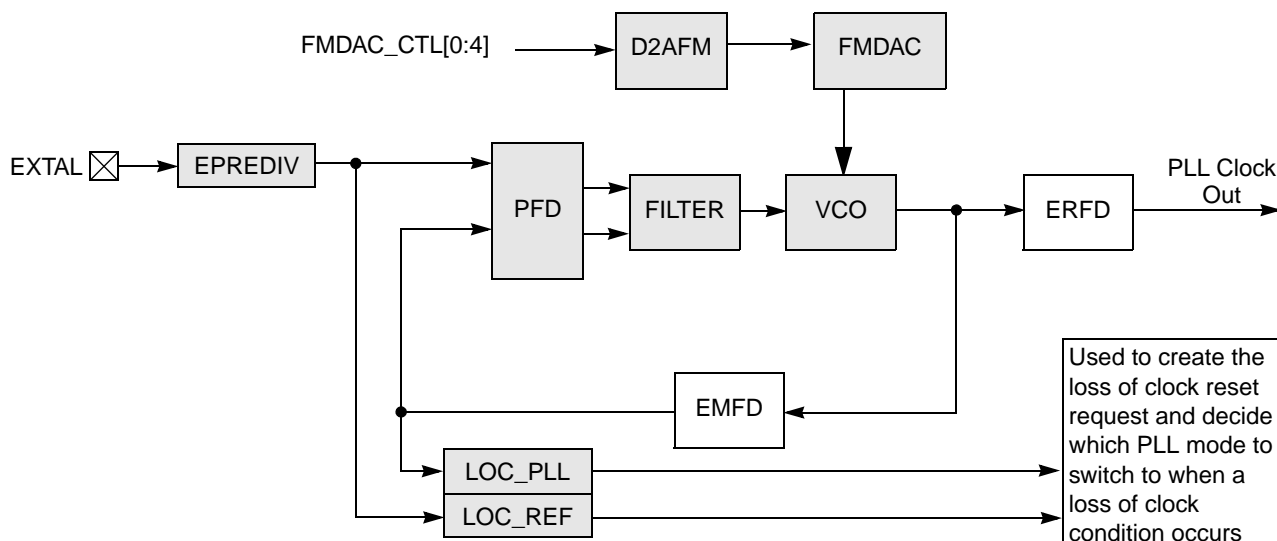

Figure 6-2. FMPLL Block Diagram

6.1.2 Features

The FMPLL has these major features (refer to *PXR40 Microcontroller Data Sheet* for performance data and restrictions):

- Input clock frequency range: 8 MHz to 40 MHz (EXTAL)
- Programmable frequency multiplication factor settings which specify VCO frequencies of 192 MHz – 600 MHz
- PLL Off mode (low-power mode)
- Register programmable output clock divider (ERFD)
- Programmable frequency modulation
 - Modulation applied as a triangle waveform
 - Peak-to-peak register programmable modulation depths

- Register programmable modulation rates of $F_{\text{extal}}/80$, $F_{\text{extal}}/40$, and $F_{\text{extal}}/20$ (modulation rate must be between 400 kHz and 1 MHz).
- Lock detect circuitry provides a signal indicating the FMPLL has acquired lock and continuously monitors the FMPLL output for any loss of lock
- Loss-of-clock circuitry monitors input reference and FMPLL output clocks with programmable ability to select a backup clock source as well as generate a reset or interrupt in the event of a failure

6.1.3 Modes of Operation

There are two main modes of FMPLL: PLL Off mode and normal mode. These modes are briefly described in this section.

When PLL Off mode is selected, the FMPLL is turned off; the clock source must come from somewhere else or the device will not function. The lock detector is not functional and does not indicate that the FMPLL is in a locked state. Frequency modulation is not available and the FMPLL is put into a low-power, idle state. A full swing square wave clock input for the entire system must be supplied on the EXTAL pin (Refer to *PXR40 Microcontroller Data Sheet* for external clock input requirements). This operating mode is described in [Section 6.4.2, PLL Off Mode](#).

When normal mode is selected, the FMPLL is fully programmable. The FMPLL reference clock source can be a crystal oscillator or an external clock generator. The lock detector indicates the lock status of the FMPLL, and frequency modulation of the output clock can be enabled. This operating mode is described in [Section 6.4.3, Normal Mode](#).

6.2 External Signal Description

Refer to [Chapter 3, Signal Descriptions](#), for detailed signal descriptions.

6.3 Memory Map and Registers

This section provides a detailed description of the FMPLL registers.

6.3.1 Module Memory Map

[Table 6-1](#) shows the FMPLL memory map. The address of each register is given as an offset to the FMPLL base address. The table lists registers in the order of their addresses, identified by complete name and mnemonic, and the type of their accesses.

Table 6-1. FMPLL Memory Map

| Offset from FMPLL_BASE_ADDR (0xC3F8_0000) | Register | Bits | Access | Reset Value | Section/Page |
|---|---|------|--------|----------------|-----------------------------|
| 0x0000 | Reserved | | | | |
| 0x0004 | SYNSR—FMPLL synthesizer status register | 32 | R/W | — ¹ | 6.3.2.1/6-4 |

Table 6-1. FMPLL Memory Map (continued)

| Offset from FMPLL_BASE_ADDR (0xC3F8_0000) | Register | Bits | Access | Reset Value | Section/Page |
|---|---|------|--------|----------------|--------------|
| 0x0008 | ESYNCR1—FMPLL enhanced synthesizer control register 1 | 32 | R/W | 0x8001_0053 | 6.3.2.2/6-7 |
| 0x000C | ESYNCR2—FMPLL enhanced synthesizer control register 2 | 32 | R/W | 0x0000_0005 | 6.3.2.3/6-9 |
| 0x0010–0x001C | Reserved | | | | |
| 0x20 | SYNFMCR—FMPLL synthesizer FM control register | 32 | R/W | — ¹ | 6.3.2.4/6-12 |

¹ See specific register description.

6.3.2 Register Descriptions

This section lists the FMPLL registers in address order and describes the registers and their bit fields.

6.3.2.1 FMPLL Synthesizer Status Register (SYNSR)

Offset: FMPLL_BASE_ADDR + 0x0004

Access: User read/write

| | | | | | | | | | | | | | | | | |
|-------|----------|----|----|----|----|----|------|-----|------|---------|---------|-------|------|------|----------------|----------------|
| | 0 | 1 | 2 | 3 | 4 | 5 | 6 | 7 | 8 | 9 | 10 | 11 | 12 | 13 | 14 | 15 |
| R | 0 | 0 | 0 | 0 | 0 | 0 | 0 | 0 | 0 | 0 | 0 | 0 | 0 | 0 | 0 | 0 |
| W | Reserved | | | | | | | | | | | | | | | |
| Reset | 0 | 0 | 0 | 0 | 0 | 0 | 0 | 0 | 0 | 0 | 0 | 0 | 0 | 0 | 0 | 0 |
| | 16 | 17 | 18 | 19 | 20 | 21 | 22 | 23 | 24 | 25 | 26 | 27 | 28 | 29 | 30 | 31 |
| R | 0 | 0 | 0 | 0 | 0 | 0 | LOLF | LOC | MODE | PLL SEL | PLL REF | LOCKS | LOCK | LOCF | U ¹ | U ¹ |
| W | Reserved | | | | | | | | | | | | | | | |
| Reset | 0 | 0 | 0 | 0 | 0 | 0 | 0 | 0 | 0 | 0 | 0 | 0 | 0 | 0 | 0 | 0 |

Figure 6-3. FMPLL Synthesizer Status Register (SYNSR)

¹ These bits may read 0 or 1, depending on current state of the PLL, however they do not provide any useful user information.

Table 6-2. SYNSR Bit Field Descriptions

| Field | Description |
|-------|-------------|
| 0–21 | Reserved |

Table 6-2. SYNSR Bit Field Descriptions (continued)

| Field | Description |
|--------------|--|
| 22 LOLF | <p>Loss-of-Lock Flag. This bit provides the interrupt request flag. To clear the flag, write a 1 to the bit. Writing 0 has no effect. The LOLF is not set in response to the following conditions:</p> <ul style="list-style-type: none"> • Loss of lock due to a system reset, or • Loss of lock due to changing any of the following: Multiplication Factor Divider (ESYNCR1_EMFD), Pre-Divider (ESYNCR1_EPREDIV), or Modulation Depth (EYSNCR2_EDEPTH) prior to the LOLF being set and cleared (for example, in response to an unexpected loss of lock condition). <p>The LOLF will be set in response to the following conditions:</p> <ul style="list-style-type: none"> • Changing any of the following: EMFD, EPREDIV, or EDEPTH subsequent to the LOLF being set and cleared (for example, in response to an unexpected loss of lock condition), or • Changing the Modulation Rate (ESYNCR2_ERATE), regardless of previous conditions. <p>If the LOLIRQ bit is set, these conditions will trigger an interrupt request.</p> <p>To avoid unintentional interrupt requests, the following steps are recommended:</p> <ul style="list-style-type: none"> • Clear the LOLIRQ bit • Change EMFD, EPREDIV, EDEPTH, and/or ERATE • Ensure the PLL is locked • Clear the LOLF bit • Set the LOLIRQ bit, if desired <p>If the flag is set due to a system failure, writing the ESYNCR1[EMFD] bits or enabling FM does not clear the flag. Assert reset to clear the flag. If lock is reacquired, the bit remains set until either a write 1 or reset is asserted.</p> <p>0 Interrupt service not requested. 1 Interrupt service requested.</p> |
| 23 LOC | <p>Loss-Of-Clock Status. The LOC bit is an indication of whether a loss-of-clock condition is present when operating in normal PLL mode. If LOC = 0, the system clocks are operating normally. If LOC = 1, the system clocks have failed due to a reference failure or a PLL failure. If the read of the LOC bit and the loss-of-clock condition occur simultaneously, the bit does not reflect the current loss-of-clock condition. If a loss-of-clock condition occurs that sets this bit and the clocks later return to normal, this bit is cleared. LOC is always zero in PLL Off mode.</p> <p>0 Clocks are operating normally. 1 Clocks are not operating normally.</p> |
| 24 MODE | <p>Clock Mode. The state of this bit, along with PLLSEL and PLLREF, indicates which clock mode the PLL is operating in (see Table 6-13). The value of ESYNCR1[CLKCFG2] is reflected in this location.</p> <p>0 PLL Off mode. 1 PLL clock mode.</p> |
| 25 PLLSEL | <p>PLL Mode Select. The state of this bit, along with MODE and PLLREF, indicates which mode the PLL operates in. This bit is cleared in PLL Off mode. The value of ESYNCR1[CLKCFG1] is reflected in this location.</p> <p>0 PLL Off mode. 1 Normal PLL mode.</p> |
| 26 PLLREF | <p>PLL Clock Reference Source. The state of this bit, along with MODE and PLLSEL, indicates which reference source has been chosen for normal PLL mode. This bit is cleared in PLL Off mode. The value of ESYNCR1[CLKCFG0] is reflected in this location.</p> <p>0 External clock reference chosen 1 Crystal clock reference chosen</p> <p>Note: The PLL controls the oscillator..</p> |

Table 6-2. SYNSR Bit Field Descriptions (continued)

| Field | Description |
|-------------|---|
| 27 LOCKS | <p>Sticky PLL Lock Status Bit. The LOCKS bit is a sticky indication of PLL lock status. LOCKS is set by the lock detect circuitry when the PLL acquires lock after: 1) a system reset, or 2) a write to the ESYNCR1 which modifies the ESYNCR1[EMFD] bits, or 3) frequency modulation is enabled. Whenever the PLL loses lock, LOCKS is cleared. LOCKS remains cleared after the PLL re-locks, until one of the three conditions occurs. Furthermore, if the LOCKS bit is read when the PLL simultaneously loses lock, the bit does not reflect the current loss-of-lock condition.</p> <p>If operating in PLL Off mode, LOCKS remains cleared after reset.</p> <p>0 PLL has lost lock since last system reset, a write to ESYNCR1 to modify the ESYNCR1[EMFD] and ESYNCR1[EPREDIV] bit fields, or frequency modulation enabled</p> <p>1 PLL has not lost lock since last system reset, a write to ESYNCR1 to modify the ESYNCR1[EMFD] and ESYNCR1[EPREDIV] bit fields, or frequency modulation enabled</p> |
| 28 LOCK | <p>PLL Lock Status Bit. The LOCK bit indicates whether the PLL has acquired lock. Refer to <i>PXR40 Microcontroller Data Sheet</i> for tolerances. If the LOCK bit is read when the PLL simultaneously loses lock or acquires lock, the bit does not reflect the current condition of the PLL.</p> <p>If operating in PLL Off mode, LOCK remains cleared after reset.</p> <p>0 PLL is unlocked</p> <p>1 PLL is locked</p> |
| 29 LOCF | <p>Loss-of-Clock Flag. This bit provides the interrupt request flag. To clear the flag, write a 1 to the bit. Writing 0 has no effect. Asserting reset clears the flag. If clocks return to normal after the flag has been set, the bit remains set until cleared by either writing 1 or asserting reset. A loss-of-clock condition can only be detected if LOCEN = 1.</p> <p>0 Interrupt service not requested.</p> <p>1 Interrupt service requested.</p> |
| 30–31 | Reserved |

6.3.2.2 FMPLL Enhanced Synthesizer Control Register 1 (ESYNCR1)

This is one of two FMPLL synthesizer control registers that are used to access enhanced features in the FMPLL. The bit fields in the ESYNCR1 behave as described in [Figure 6-4](#).

Offset: FMPLL_BASE_ADDR + 0x0008

Access: User read/write

| | | | | | | | | | | | | | | | | |
|-------|----------------|----------------|----------------|----------------|----|----|----|----|------|----|----|----|---------|----|----------------|----|
| | 0 | 1 | 2 | 3 | 4 | 5 | 6 | 7 | 8 | 9 | 10 | 11 | 12 | 13 | 14 | 15 |
| R | 1 | CLKCFG[2:0] | | | 0 | 0 | 0 | 0 | 0 | 0 | 0 | 0 | EPREDIV | | | |
| W | | | | | | | | | | | | | | | | |
| Reset | 1 | — ¹ | — ¹ | — ¹ | 0 | 0 | 0 | 0 | 0 | 0 | 0 | 0 | 0 | 0 | — ² | 1 |
| | 16 | 17 | 18 | 19 | 20 | 21 | 22 | 23 | 24 | 25 | 26 | 27 | 28 | 29 | 30 | 31 |
| R | 0 | 0 | 0 | 0 | 0 | 0 | 0 | 0 | EMFD | | | | | | | |
| W | 0 ³ | | | | | | | | | | | | | | | |
| Reset | 0 | 0 | 0 | 0 | 0 | 0 | 0 | 0 | 0 | 0 | 1 | 0 | 0 | 0 | 0 | 0 |

¹ Reset value determined by PLLCFG pins during reset.

² Resets to value of PLLCFG[2] (0 if PLLCFG[2]=0; 1 if PLLCFG[2]= 1)

³ Do not set this bit to 1.

Figure 6-4. FMPLL Enhanced Synthesizer Control Register 1 (ESYNCR1)

Table 6-3. ESYNCR1 Bit Field Descriptions

| Field | Description |
|--------------------|--|
| 0 | Reserved. Note: This bit is set to 1 on reset and always reads as 1. Writes to this bit have no effect. |
| 1–3 CLKCFG[2:0] | Clock Configuration. The CLKCFG[2:0] bits are writable versions of the MODE, PLLSEL, and PLLREF bits in the SYNCR. These change the clock mode, after reset has negated, via software. CLKCFG[2:0] map directly to MODE, PLLSEL, and PLLREF to control the system clock mode. Note: CLKCFG = 0b101 (or any reserved/invalid value) can produce an unpredictable clock output. Note: The ESYNCR2[LOLRE] and ESYNCR2[LOCRE] should be set to 0 before changing the PLL mode, so that a reset is not immediately generated when CLKCFG is written. |
| 4–11 | Reserved |
| 12–15 EPREDIV | Enhanced Pre-Divider. The EPREDIV bits control the value of the divider on the input clock. The output of the pre-divider circuit generates the reference clock to the PLL analog loop. The decimal equivalent of the EPREDIV binary number is substituted into the equation from Table 6-8 . Note: Setting EPREDIV to any of the invalid states in Table 6-4 causes the PLL to produce an unpredictable output clock. The output frequency of the divider must equal f_{pllref} (see the <i>PXR40 Microcontroller Data Sheet</i>). When the EPREDIV bits are changed, the PLL immediately loses lock. Do not change the EPREDIV bits during FM operation. Before changing EPREDIV, FM must be disabled and then reconfigured after the PLL re-locks to the new EPREDIV value. To prevent an immediate reset, clear the LOLRE bit before writing the EPREDIV bits. In PLL Off mode, the EPREDIV bits have no effect. |

Table 6-3. ESYNCR1 Bit Field Descriptions (continued)

| Field | Description |
|---------------|---|
| 16–23 | Reserved. Note: Do not set this bit to 1. |
| 24–31 EMFD | Enhanced Multiplication Factor Divider. The EMFD bits control the value of the divider in the PLL feedback loop. The value specified by the EMFD bits establish the multiplication factor applied to the reference frequency. The decimal equivalent of the EMFD binary number is substituted into the equation from Table 6-10 for F_{sys} to determine the equivalent multiplication factor. The range of settings is $32 \leq EMFD \leq 132$. Note: EMFD values less than 32 and greater than 132 are invalid and cause the PLL to produce an unpredictable clock output. The VCO frequency must be within the f_{VCO} specification (see the <i>PXR40 Microcontroller Data Sheet</i>). When the EMFD bits are changed, the PLL loses lock. Do not change the EMFD bits during FM operation. Before changing EMFD, FM must be disabled and then reconfigured after the PLL re-locks to the new EMFD value. To prevent an immediate reset, clear the LOLRE bit before writing the EMFD bits. In PLL Off mode, the EMFD bits have no effect. Table 6-5 shows the available divide ratios. |

Table 6-4. Pre-divider Ratios

| EPREDIV | Input Divide Ratio (EPREDIV+1) |
|-----------|--------------------------------|
| 0000 | 1 |
| 0001 | 2 (default if PLLCFG[2]=0) |
| 0010 | 3 |
| 0011 | 4 (default if PLLCFG[2]=1) |
| 0100 | 5 |
| 0101 | 6 |
| 0110 | Invalid |
| 0111 | 8 |
| 1000 | Invalid |
| 1001 | 10 |
| 1010–1111 | Invalid |

Table 6-5. Feedback Divide Ratios

| EMFD | Feedback Divide Ratio (EMFD+16) |
|---------------------|---------------------------------|
| 0000_0000–0001_1111 | Invalid |
| 0010_0000 | 48 (default for PXR40) |
| 0010_0001 | 49 |
| 0010_0010 | 50 |
| 0010_0011 | 51 |
| 0010_0100 | 52 |

Table 6-5. Feedback Divide Ratios

| EMFD | Feedback Divide Ratio (EMFD+16) |
|-------------------------------|---------------------------------|
| 0010_0101 | 53 |
| · · 0101_0011 · · | · · 99 · · |
| 1000_0100 | 132 |
| 1000_0101–1111_1111 | Invalid |

6.3.2.3 FMPLL Enhanced Synthesizer Control Register 2 (ESYNCR2)

This is the second of two enhanced versions of the FMPLL synthesizer control register used to access enhanced features in the FMPLL. The bit fields in the ESYNCR2 behave as described in [Figure 6-5](#).

Offset: FMPLL_BASE_ADDR + 0x000C

Access: User read/write

| | | | | | | | | | | | | | | | | |
|-------|--------------------|----|----|----|----|--------|----|----|-------|-------|-------|------------|------------|----|-------|----|
| | 0 | 1 | 2 | 3 | 4 | 5 | 6 | 7 | 8 | 9 | 10 | 11 | 12 | 13 | 14 | 15 |
| R | 0 | 0 | 0 | 0 | 0 | 0 | 0 | 0 | LOCEN | LOLRE | LOCRE | LOL IRQ | LOC IRQ | 0 | ERATE | |
| W | | | | | | | | | | | | | | | | |
| Reset | 0 | 0 | 0 | 0 | 0 | 0 | 0 | 0 | 0 | 0 | 0 | 0 | 0 | 0 | 0 | 0 |
| | 16 | 17 | 18 | 19 | 20 | 21 | 22 | 23 | 24 | 25 | 26 | 27 | 28 | 29 | 30 | 31 |
| R | CLK CFG _DIS | 0 | 0 | 0 | 0 | EDEPTH | | | | 0 | 0 | ERFD | | | | |
| W | | | | | | | | | | | | | | | | |
| Reset | 0 | 0 | 0 | 0 | 0 | 0 | 0 | 0 | 0 | 0 | 0 | 0 | 0 | 1 | 1 | 1 |

Figure 6-5. FMPLL Enhanced Synthesizer Control Register 2 (ESYNCR2)
Table 6-6. ESYNCR2 Bit Field Descriptions

| Field | Description |
|------------|---|
| 0–7 | Reserved |
| 8 LOCEN | Loss-of-Clock Enable. The LOCEN bit determines whether the loss-of-clock function is operational along with backup clock modes, and interrupt and reset functions. See Section 6.4.3.2, Loss-of-Clock Detection , for more information. In PLL Off mode, this bit has no effect. LOCEN does not affect the loss-of-lock circuitry. 0 Loss-of-clock disabled. 1 Loss-of-clock enabled. |
| 9 LOLRE | Loss-of-Lock Reset Enable. The LOLRE bit determines how the integration module handles a loss-of-lock indication. See Section 6.4.3.1, PLL Lock Detection , for more information. When operating in normal PLL mode, the PLL must be locked before setting the LOLRE bit. Otherwise reset is immediately asserted. The LOLRE bit has no effect in PLL Off mode. 0 Assert reset on loss of lock is disabled. 1 Assert reset on loss of lock. |

Table 6-6. ESYNCR2 Bit Field Descriptions (continued)

| Field | Description |
|------------------------------|---|
| 10 LOCRE | Loss-of-Clock Reset Enable. The LOCRE bit determines how the integration module handles a loss-of-clock condition when LOCEN is equal to 1. LOCRE has no effect when LOCEN is equal to 0. If the LOCF bit in the SYNSR indicates a loss-of-clock condition, setting the LOCRE bit causes an immediate reset. The LOCRE bit has no effect in PLL Off mode. 0 Assert reset on loss of clock is disabled. 1 Assert reset on loss of clock. |
| 11 LOLIRQ | Loss-of-Lock Interrupt Request. The LOLIRQ bit determines how the integration module handles a loss-of-lock indication. See Section 6.6.1, Loss-of-Lock Interrupt Request , for more information. When operating in normal mode, the PLL must be locked before setting the LOLIRQ bit. Otherwise an interrupt is immediately requested. The LOLIRQ bit has no effect in PLL Off mode. 0 Request interrupt is disabled. 1 Request interrupt. |
| 12 LOCIRQ | Loss- of-Clock Interrupt Request. The LOCIRQ bit determines how the integration module handles a loss-of-clock condition when LOCEN = 1. LOCIRQ has no effect when LOCEN = 0. If the LOCF bit in the SYNSR indicates a loss-of-clock condition, setting (or having previously set) the LOCIRQ bit causes an interrupt request. The LOCIRQ bit has no effect in PLL Off mode. 0 Request interrupt on loss of clock is disabled. 1 Request interrupt on loss of clock. |
| 13 | Reserved |
| 14–15 ERATE ¹ | Enhanced Modulation Rate. The ERATE bits control the rate of frequency modulation applied to the system frequency. Table 6-7 shows the allowable modulation rates. |
| 16 CLKCFG_DIS | The CLKCFG_DIS bit is used to disable the ability to change the PLL mode using the CLKCFG bits. This protects the system from errant software writes and/or bit flips on the CLKCFG[2:0] bits that could change the PLL clock mode. Note: If the PLL is configured for PLL Off mode when the CLKCFG_DIS bit is set, the PLL will automatically enter normal mode. For this reason, it is advisable to set the PLL for the desired mode (normal mode with crystal reference or normal mode with external reference) before setting the CLKCFG_DIS bit to protect from inadvertent mode changes. 0 Writes to CLKCFG[2:0] enabled. 1 Writes to CLKCFG[2:0] disabled. |
| 17–20 | Reserved |
| 21–23 EDEPTH ² | Enhanced Modulation Depth. The EDEPTH bit field controls the frequency modulation depth ² , and in conjunction with the SYNFMCR[FMDAC_EN] bit enables frequency modulation. The EDEPTH bit must be set to a non-zero value for FM operation. The sequence for enabling and configuring FM operation is described in Section 6.4.3.4.2, Programming System Clock Frequency With Frequency Modulation . This program sequence must be followed exactly to insure proper operation of the FM. |
| 24–25 | Reserved |

Table 6-6. ESYNCR2 Bit Field Descriptions (continued)

| Field | Description |
|---------------|---|
| 26–31 ERFD | <p>Enhanced Reduced Frequency Divider. The ERFD bits control a divider at the output of the PLL. The value specified by the ERFD bits establish the divisor applied to the PLL frequency. The ERFD divides the output clock by the quantity (ERFD + 1). Even-numbered ERFD settings, which would result in odd divide ratios, are not allowed.</p> <p>The decimal equivalent of the ERFD binary number is substituted into the equation from Table 6-10.</p> <p>Note: The ERFD divides the output clock by the quantity (ERFD + 1). Even numbered ERFD settings, which would result in odd divide ratios, are invalid and cause the PLL to produce an unpredictable output clock. The PLL output clock must be within the f_{PLL} specification (see the <i>PXR40 Microcontroller Data Sheet</i>).</p> <p>Changing the ERFD bits does not affect the PLL, hence, no re-lock delay is incurred. Resulting changes in clock frequency are synchronized to the next falling edge of the current system clock. These bits should be written only when the lock bit (LOCK) is set, to avoid surpassing the allowable system operating frequency. In PLL Off mode, the ERFD bits have no effect.</p> <p>The available output divider ratios are given in Table 6-8.</p> |

- ¹ ERATE and EDEPTH must be enabled simultaneously to avoid unintentional assertion of the LOLF. Program the desired modulation rate and depth to the ERATE and EDEPTH bit fields simultaneously with a single 32 bit write to the ESYNCR2 register.
- ² Auto-calibration is not available on the PXR40 device. EDEPTH does not set modulation depth and is used only in conjunction with the SYNFMCR[FMDAC_EN] to enable FM. See [Section 6.4.3.4, PLL Normal Mode With Frequency Modulation](#)".

Table 6-7. Programmable Modulation Rates

| ERATE | Modulation Rate (Hz) |
|-------|--------------------------|
| 00 | $F_{mod} = F_{extal}/80$ |
| 01 | $F_{mod} = F_{extal}/40$ |
| 10 | $F_{mod} = F_{extal}/20$ |
| 11 | Invalid |

Table 6-8. Output Divide Ratios

| ERFD | Output Divide Ratio (ERFD+1) |
|---------|--|
| 00_0000 | Divide-by-1 |
| 00_0001 | Divide-by-2 |
| 00_0010 | Invalid |
| 00_0011 | Divide-by-4 |
| 00_0100 | Invalid |
| 00_0101 | Divide-by-6 |
| 00_0110 | Invalid |
| 00_0111 | Divide-by-8 (default value for PXR40) |

Table 6-8. Output Divide Ratios

| ERFD | Output Divide Ratio (ERFD+1) |
|---------|------------------------------|
| . | . |
| . | . |
| . | . |
| 11_1100 | Invalid |
| 11_1101 | Divide-by-62 |
| 11_1110 | Invalid |
| 11_1111 | Divide-by-64 |

6.3.2.4 FMPLL Synthesizer FM Control Register (SYNFMCR)

The synthesizer FM control register (SYNFMCR) contains bits for enabling and configuring PLL frequency modulation.

Offset: FMPLL_BASE_ADDR + 0x0020

Access: User read/write

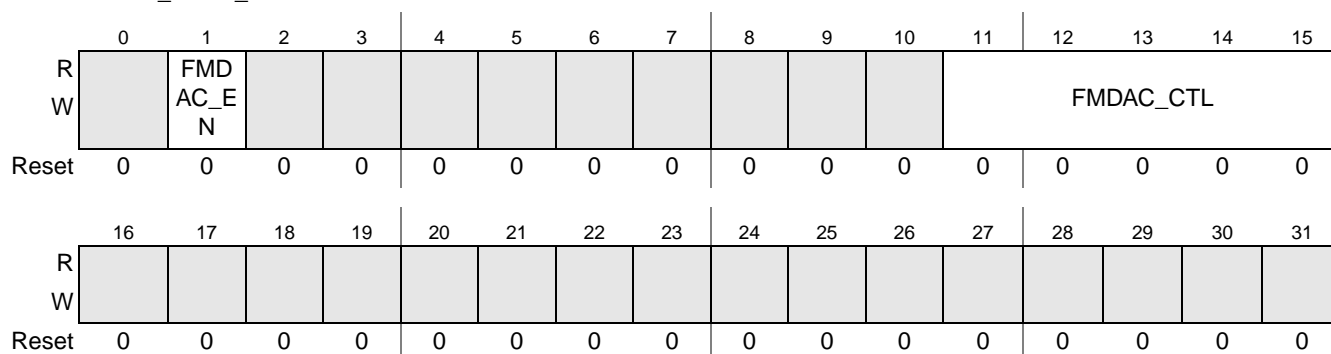

Figure 6-6. FMPLL Synthesizer FM Control Register (SYNFMCR)

Table 6-9. ESYNFMCR Bit Field Descriptions

| Field | Description |
|---------------|--|
| 0 | Reserved |
| 1 FMDAC_EN | Frequency Modulation Register Enable. When this bit is set, the FMDAC_CTL field is enabled and the FM depth can be controlled directly by the value in FMDAC_CTL. The ESYNCR2[EDEPTH] field must also be set to a non-zero value to enable FM. 0 FMDAC_CTL disabled. 1 FMDAC_CTL enabled. DAC is controlled by the value in FMDAC_CTL. |
| 2-10 | Reserved |

Table 6-9. ESYNFMCR Bit Field Descriptions

| Field | Description |
|--------------------|---|
| 11–15 FMDAC_CTL | <p>Digital-to-Analog Converter Control. This bitfield value is written to the DAC to control the FM depth by percentage during FM operation.</p> <ul style="list-style-type: none"> 00100 – 1% 01000 – 2% 01100 – 3% 10000 – 4% <p>These values have been shown in characterization data to produce the specified FM percentage within the device specification. However, the user may program intermediate values to trim the FM percentage for a specific application if desired. Do not program FMDAC_CTL to any value that will cause the system frequency to exceed the maximum specification.</p> |
| 16–0 | Reserved |

6.4 Functional Description

The FMPLL module contains the frequency modulated phase lock loop (FMPLL), enhanced frequency divider (ERFD), enhanced synthesizer control registers (ESYNCR1 and ESYNCR2), synthesizer status register (SYNSR), synthesizer FM control register (SYNFMCR) and clock/PLL control logic. The block also contains a reference frequency pre-divider controlled by the EPREDIV bits in the ESYNCR1. This enables the user to use a high frequency crystal or external clock generator and obtain finer frequency synthesis resolution than would be available if the raw input clock were used directly by the analog loop. For the remainder of this chapter, the term “reference frequency” and the symbol F_{ref} indicate the output of the pre-divider circuit. This is the clock on which frequency multiplication is performed.

6.4.1 General

The system clock source is determined during reset as shown in [Table 6-13](#). The value of the PLLCFG[0:1] pins are latched during reset. If PLLCFG[0:1] are changed during a reset other than power-on reset, the internal clocks may glitch as the clock source is changed between PLL Off mode and PLL clock mode or from one PLL clock mode to another. Whenever PLLCFG[0:1] are changed in reset to a value other than what it was before the reset, an immediate loss of lock condition is declared. This only applies if the PLL was running in a locked state prior to the assertion of reset and change of PLLCFG[0:1].

[Table 6-10](#) shows the PLL clock to input clock frequency relationships for the available clock modes.

Table 6-10. Clock-Out vs. Clock-In Relationships

| Clock Mode | Frequency Equation |
|------------------------------|---|
| PLL Off Mode | $F_{PLL} = F_{extal}$ |
| Normal PLL Mode ¹ | $F_{PLL} = \frac{F_{extal} \cdot (EMFD + 16)}{(EPREDIV + 1)(ERFD + 1)}$ |

¹ Equation to be used when programming enhanced control registers (ESYNCR1 and ESYNCR2). See EPREDIV, EMFD, and ERFD bitfield descriptions for valid ranges for these fields.

6.4.2 PLL Off Mode

When PLL Off mode is selected, the PLL is turned off. The user must supply an external clock on the EXTAL pin and select that clock source before entering PLL Off mode. The selected clock is directly used to produce the various system clocks. Refer to *PXR40 Microcontroller Data Sheet* for external clock input requirements. In PLL Off mode, the analog portion of the PLL is disabled, the frequency modulation capability is not available, and no clocks are generated at the PLL output. The pre-divider is bypassed and has no effect on the system clock frequency in PLL Off mode.

6.4.3 Normal Mode

When normal PLL mode is selected, the PLL is fully programmable. The PLL can synthesize frequencies ranging from 48x to 148x the reference frequency of the output of the predivider, with or without

frequency modulation enabled. The post-divider is capable of reducing the PLL clock frequency without forcing a re-lock. The PLL reference can be a crystal oscillator reference or an external clock reference. This clock is divided by the pre-divider circuit to create the PLL reference clock.

6.4.3.1 PLL Lock Detection

The lock detect logic monitors the reference frequency and the PLL feedback frequency to determine when frequency lock has been achieved. Phase lock is inferred by the frequency relationship, but is not guaranteed. The PLL lock status is reflected in the LOCK status bit in the SYNSR. A sticky lock status indication, LOCKS, is also provided.

The lock detect function uses two counters, which are clocked by the reference and PLL feedback respectively. When the reference counter has counted N cycles, the feedback counter's count is compared. If the feedback counter has also counted N cycles, the process is repeated for $N + K$ counts. Then if the two counters' counts match, the lock criteria is relaxed by one count and the system is notified that the PLL has achieved frequency lock. After three successful compares, the tolerance is relaxed.

After lock has been detected, the lock circuitry continues to monitor the reference and feedback frequencies using the alternate count and compare process. If the counters do not match at any comparison time, then the LOCK status bit is cleared to indicate that the PLL has lost lock. At this point, the lock criteria is tightened and the lock detect process is repeated.

The alternate count sequences prevent false lock detects due to frequency aliasing while the PLL tries to lock. Alternating between a tight and relaxed lock criteria prevents the lock detect function from randomly toggling between locked and not locked status due to phase sensitivities. [Figure 6-7](#) illustrates the sequence for detecting locked and not-locked conditions.

When the frequency modulation is enabled, the loss of lock continues to function as described but with the lock and loss of lock criteria reduced to ensure that false loss of lock conditions are not detected.

In PLL Off mode, the PLL cannot lock because the PLL is disabled.

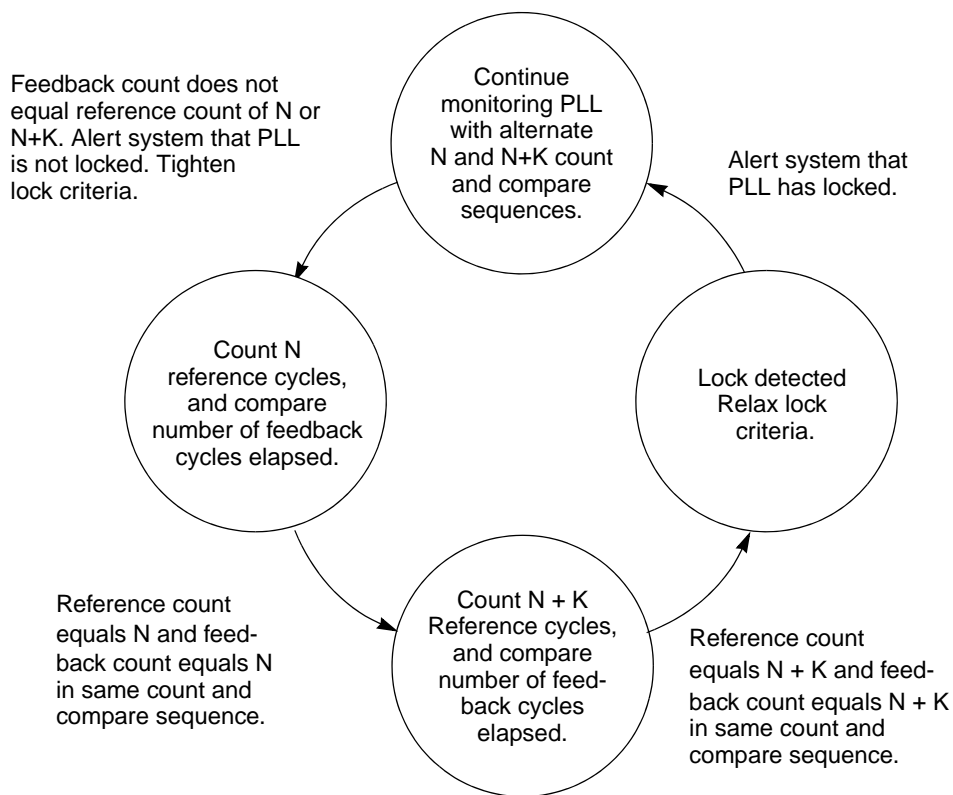

Figure 6-7. Lock Detect Sequence

After the PLL acquires lock after reset, the LOCK and LOCKS status bits are set. If the EPREDIV or EMFD are changed, or if an unexpected loss-of-lock condition occurs, the LOCK and LOCKS status bits are negated. While the PLL is in an unlocked condition, the system clocks continue to be sourced from the PLL as the PLL attempts to re-lock. Consequently, during the re-locking process, the system clock frequency is not well defined and may exceed the maximum system frequency violating the system clock timing specifications. Because of this condition, use of the loss-of-lock reset function is recommended.

After the PLL has re-locked, the LOCK bit is set. The LOCKS bit remains cleared if the loss of lock was unexpected. The LOCKS bit is set to one when the loss of lock was caused by changing the EPREDIV or EMFD fields.

6.4.3.2 Loss-of-Clock Detection

When enabled by the LOCEN bit in the ESYNCR2, the loss-of-clock (LOC) detection circuit monitors the input clocks to the phase/frequency detector (PFD) (see Figure 6-2). When the reference or feedback clock frequency falls below a minimum frequency, the LOC circuitry considers the clock to have failed and a loss-of-clock status is reflected by the sticky LOCF bit, and non-sticky LOC bit in the SYNSR. See *PXR40 Microcontroller Data Sheet* for the minimum clock frequency. In PLL Off mode, the loss-of-clock circuitry is disabled.

Depending which clock source has failed, the LOC circuitry switches the PLL output clock's source to the remaining operational clock if enabled by LOCEN. The PLL output clocks are derived from the alternate clock source until reset is asserted. The alternate clock source used is dependent on whether the LOC is

caused by a reference clock failure or a PLL failure. If the reference fails, the PLL goes out of lock and into self-clocked mode (SCM) (see [Table 6-11](#)). The PLL remains in SCM until the next reset. When the PLL is operating in SCM, the PLL runs open loop at a default VCO frequency. The RFD will set to divide-by-6 to ensure the clock presented to the system is well below the maximum allowable frequency for the device. If the loss-of-clock condition is due to a PLL failure (i.e., loss of feedback clock), the PLL reference becomes the system clock source until the next reset, even if the PLL regains itself and re-locks.

Table 6-11. Loss-of-Clock Summary

| Clock Mode | System Clock Source before Failure | REFERENCE FAILURE Alternate Clock Selected by LOC Circuitry until Reset | PLL FAILURE Alternate Clock Selected by LOC Circuitry until Reset |
|------------|------------------------------------|--|--|
| PLL | PLL | PLL self-clocked mode | PLL reference |
| PLL Off | Ext. Clock(s) | None | NA |

Note: The LOC circuit monitors the inputs to the PFD: reference and feedback clocks (see [Figure 6-2](#)).

A special loss-of-clock condition occurs when both the reference and the PLL fail. The failures may be simultaneous or the PLL may fail first. In either case, the reference clock failure takes priority and the PLL attempts to operate in SCM. If successful, the PLL remains in SCM until the next reset. During SCM, modulation is always disabled. If the PLL cannot operate in SCM, the system remains static until the next reset. Both the reference and the PLL must be functioning properly to exit reset.

6.4.3.3 PLL Normal Mode Without FM

In PLL mode, the system clocks are synthesized by the FMPLL by multiplying up the reference clock frequency. It is critical that the system clock frequency remain within the range for the device (see *PXR40 Microcontroller Data Sheet*). The output of the FMPLL can be divided down in powers of 2 up to 64 to reduce the system frequency with the ERFD. The ERFD is not contained in the feedback loop of the PLL, so changing the ERFD bits does not affect FMPLL operation. Finally, the PLL can be frequency modulated to reduce electromagnetic interference often associated with clock circuitry. [Figure 6-2](#) shows the overall block diagram for the PLL. Each of the major blocks is discussed briefly in the following sections.

6.4.3.3.1 Phase/Frequency Detector

The phase/frequency detector (PFD) is a dual-latch phase-frequency detector. It compares both the phase and frequency of the reference clock and the feedback clock. The reference clock comes from the crystal oscillator or an external clock source. The feedback clock comes from the VCO output divided down by the EMFD in normal PLL mode.

When the frequency of the feedback clock equals the frequency of the reference clock (i.e., the PLL is frequency locked), the PFD pulses the UP or DOWN signals depending on the relative phase of the two clocks. If the falling edge of the reference clock leads the falling edge of the feedback clock, then the UP signal is pulsed. If the falling edge of the feedback clock leads the falling edge of the reference clock, then the DOWN signal is pulsed. The width of these pulses relative to the reference clock is dependent on how much the two clocks lead or lag each other. After phase lock is achieved, the PFD continues to pulse the UP and DOWN signals for a very short duration during each reference clock cycle. These short pulses

force the PLL to continually update and prevent a frequency drift phenomena referred to as “dead-banding.” Dead-band describes the minimum amount of phase error between the reference and feedback clocks that a phase detector cannot correct.

6.4.3.3.2 Charge Pump/Loop Filter

Operation of the charge pump is controlled by the UP and DOWN signals from the PFD. They control whether the charge pumps apply or remove charge, respectively, from the loop filter.

6.4.3.3.3 VCO

The voltage into the VCO controls the frequency of its output. The frequency-to-voltage relationship (VCO gain) is positive.

6.4.3.3.4 EMFD

The MFD divides down the output of the VCO and feeds it back to the PFD. The PFD controls the VCO frequency (via the charge pump and loop filter) such that the reference and feedback clocks have the same frequency and phase. Thus, the input to the MFD, which is also the output of the VCO, is at a frequency that is the reference frequency multiplied by the same amount the MFD divides by. For example, if the MFD divides the VCO frequency by 48, then the PLL is frequency locked when the VCO frequency is 48 times the reference frequency. The presence of the MFD in the loop allows the PLL to perform frequency multiplication, or synthesis.

6.4.3.3.5 Programming System Clock Frequency

In normal PLL clock mode, the default system frequency is determined by the default EPREDIV, EMFD, and ERFD values.

When programming the PLL, do not violate the maximum system clock frequency or max/min VCO frequency specifications. Based on the desired system clock frequency, EPREDIV, EMFD, and ERFD must be calculated for the given crystal or external reference frequency. See *PXR40 Microcontroller Data Sheet* for the max/min VCO frequency range and the maximum allowable system frequency.

Frequency modulation should be disabled prior to changing the EPREDIV, EMFD, or ERATE bit fields. A change to EPREDIV, EMFD, EDEPTH, or ERATE while modulation is enabled invalidates the previous FM depth configuration.

Use these directions to accommodate the frequency overshoot that occurs when the EPREDIV or EMFD bits are changed. If frequency modulation is going to be enabled the maximum allowable frequency must be reduced by the programmed ΔF_m .

1. Determine the appropriate value for the EPREDIV, EMFD, and ERFD fields in the synthesizer control register(s), remember to include the ΔF_m if frequency modulation is to be enabled. The amount of jitter in the system clocks can be minimized by selecting the maximum EMFD factor that can be paired with an ERFD factor to provide the desired frequency. The maximum EMFD value that can be used is determined by the VCO and EMFD range.

2. Write a value of $ERFD = ERFD$ (from step 1) + 2 to the ERFD field of the ESYNCR2. Not increasing the ERFD when changing the EPREDIV or EMFD could subject the device to clock frequencies beyond the range specified for the device due to the PLL's unlocked state.
3. If frequency modulation is currently enabled, disable it by writing 00 to the EDEPTH field of the ESYNCR2.
4. If programming the EPREDIV and/or EMFD, write the value(s) determined in step 1 to the appropriate field(s) in the ESYNCR1.
5. Monitor the synthesizer lock bit (LOCK) in the synthesizer status register (SYNSR). When the PLL achieves lock, write the ERFD value determined in step 1 to the ERFD field of the ESYNCR2. This changes the system clocks frequency to the desired frequency. If frequency modulation is desired, leave ERFD programmed to $ERFD + 2$ until after completing the steps in [Section 6.4.3.4.2, Programming System Clock Frequency With Frequency Modulation](#).
6. If frequency modulation was enabled initially, it can be re-enabled following the steps listed in [Section 6.4.3.4.2, Programming System Clock Frequency With Frequency Modulation](#).

During startup, current transients on the VDD supply are related to the system frequency. A technique can be used to reduce these current transients when the system frequency is changed from its default value to your desired frequency.

Follow the above procedure for step 1. In step 2, rather than set ERFD to $ERFD$ (from step 1) + 2, set this to a value which will produce a low system frequency (close to the default system frequency), e.g. $ERFD = ERFD$ (from step 1) + 4. Once set, follow steps 3 and 4 as above. In step 5, wait for the LOCK bit to set, then set the EFRD bit to $ERFD$ (from step 2) - 2. Wait for a small duration of time for the current to stabilize, then repeat this procedure until the ERFD value is equal to the value determined in step 1.

Using this technique you should observe the system frequency increasing in steps to the desired system frequency. This results in the VDD current increasing to its equivalent final value in smaller current steps which, therefore, produce smaller current transients, making it easier for the power supply to handle.

6.4.3.4 PLL Normal Mode With Frequency Modulation

In normal PLL clock mode, frequency modulation is not enabled in the default synthesis mode. When frequency modulation is enabled several parameters must be set to generate the desired level of modulation. The parameters to be programmed are the ERATE and EDEPTH bit fields of the ESYNCR2 register and the FMDAC_EN and FMDAC_CTL bits in the SYNFMCR register. The ERATE bit controls the frequency of modulation, F_{mod} . The EDEPTH bits work in conjunction with the FMDAC_CTL bits in the SYNFMCR to enable and control the modulation depth, F_m . The available modulation rates and depths are given in [Table 6-7](#) and [Table 6-8](#), respectively. The modulation waveform is always a triangle wave and its shape is not programmable. An example of one period of the modulation waveform is shown in [Figure 6-8](#).

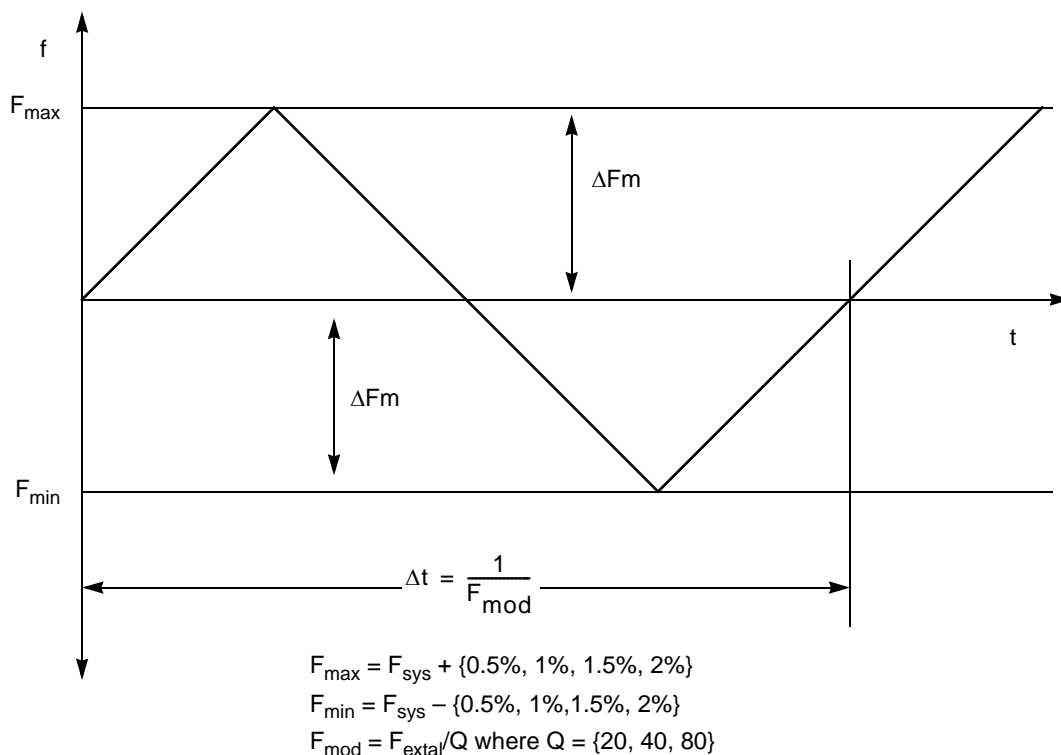

Figure 6-8. Frequency Modulation Waveform

6.4.3.4.1 Frequency Modulation Control

The frequency modulation control consists of programming a reference current into the modulation D/A so that the modulation depth (F_{\max} and F_{\min}) remains within specification. Disable frequency modulation prior to changing the EPREDIV, EMFD, or ERATE bit fields. Upon enabling frequency modulation a new configuration sequence is required. Do not change EPREDIV, EMFD or ERATE while modulation is active or unpredictable results may occur.

6.4.3.4.2 Programming System Clock Frequency With Frequency Modulation

The following steps illustrate proper programming of the frequency modulation mode. These steps ensure proper operation of the FM configuration routine and prevent frequency overshoot from the programming sequence. The PLL should be programmed and allowed to lock in non-FM mode at the desired frequency as outlined in [Section 6.4.3.3.5, Programming System Clock Frequency](#).

1. Write a value of $ERFD = ERFD + 2$ to the ERFD field of the ESYNCR2 to ensure the maximum system frequency is not exceeded during the FM configuration. This is done when allowing the PLL to lock in non-FM mode.

NOTE

Even numbered ERFD settings, which would result in odd divide ratios, are invalid and cause the PLL to produce an unpredictable output clock. The PLL output clock must be within the f_{PLL} specification

- Write the SYNFMCR[FMDAC_EN] bit to logical 1 (to enable FMDAC_CTL) and the SYNFMCR[FMDAC_CTL] bit field to the appropriate value shown in [Table 6-12](#).

Table 6-12. FMDAC_CTL settings for FM Configuration

| Peak-to-Peak FM depth (EDEPTH) | FMDAC_CTL |
|------------------------------------|-----------|
| 1% (center frequency $\pm 0.5\%$) | 0x04 |
| 2% (center frequency $\pm 1.0\%$) | 0x08 |
| 3% (center frequency $\pm 1.5\%$) | 0x0C |
| 4% (center frequency $\pm 2.0\%$) | 0x10 |

- Program the desired modulation rate into the ERATE field of the ESYNCR2 register and set the EDEPTH field to a non-zero value. The absolute value in the EDEPTH field is non-critical as this value is not used for actual FM depth, however EDEPTH must be non-zero to enable FM. Make sure not to change ERFD from step 2 when setting ERATE and EDEPTH as they share the same register space.
- Wait for the PLL to lock. When the PLL achieves lock, write the desired ERFD value. Make sure not to modify ERATE/EDEPTH as they share the same register space.

The frequency modulation system is dependent on several factors, including the accuracies of the V_{DDSYN}/V_{SSSYN} voltage, of the crystal oscillator frequency, and of the manufacturing variation.

For example, if a 5% accurate supply voltage is used, then a 5% modulation depth error results. If the crystal oscillator frequency is skewed from the nominal operating frequency, the resulting modulation frequency is proportionally skewed. Finally, the error due to the manufacturing and environment variation alone can cause the frequency modulation depth error to be greater than 20%.

6.5 Resets

This section describes the reset operation of the PLL, including power-on reset and normal resets. The reset values of registers and signals are provided in other sections.

6.5.1 Clock Mode Selection

The initial clock mode is reflected in the MODE, PLLSEL, and PLLREF bits of the synthesizer status register (SYNSR) as well as the ESYNCR1[CLKCFG[2:0]] bit field. The clock mode can be modified by writing to the CLKCFG[2:0] bit field. The synthesizer status register then reflects the newly-selected PLL clock mode.

Table 6-13 summarizes clock mode selection.

Table 6-13. Clock Mode Selection

| Package Pins ¹ | | Clock Mode | Synthesizer Status Register (SYNSR) MODE, PLLSEL, and PLLREF Bits | | |
|---------------------------|-----------|-------------------------------------|--|----------------------|----------------------|
| PLLCFG[0] | PLLCFG[1] | | MODE/ CLKCFG[2] | PLLSEL/ CLKCFG[1] | PLLREF/ CLKCFG[0] |
| 0 | 0 | PLL Off mode | 0 | X | X |
| 0 | 1 | Normal mode with external reference | 1 | 1 | 0 |
| 1 | 0 | Normal mode with crystal reference | 1 | 1 | 1 |
| 1 | 1 | Reserved | 1 | 0 | 0 |

¹ The PLLCFG[2] pin configures the crystal oscillator range:
 PLLCFG[2] = 0, for 8 MHz to 20 MHz
 PLLCFG[2] = 1, for 40 MHz

6.5.1.1 Power-On Reset (POR)

The PLL will not operate until the POR state has ended. Refer to *PXR40 Microcontroller Data Sheet* for these thresholds. At this point, the PLL operates in self-clocked mode (SCM) until a valid reference clock is detected by the internal clock monitor circuit.

Internal to the PLL, the VCO is held in reset until the negation of the POR signal. This prevents the PLL from attempting to lock before its supplies are within specification, which can cause VCO/loop gain to be lower than what the analog loop is designed for.

6.5.1.2 External Reset

After POR has negated, the PLL will begin its lock detect algorithm if Normal Mode is selected. However, if a valid reference is not present, the PLL will continue to operate in Self Clocked Mode until one is present. PLL configuration at POR may be selected by external pins PLLCFG[0:1] or reset state values of configuration registers.

After the initial lock with the default divider settings (assuming Normal Mode was selected), you may write to the SYNCR/ESYNCR(s) to modify the dividers for the desired operating frequency. The PLL may

not be able to lock due to an (E)MFD and crystal frequency combination that attempts to force the VCO outside of its operating range

CAUTION

When running in an unlocked state, the clocks generated by the PLL are not guaranteed stable and may exceed the maximum specified operating frequency of the device. The RFD should always be used as described in [Section 6.4.3.3.5, Programming System Clock Frequency](#), to insulate the system from any potential frequency overshoot of the PLL clocks.

6.5.2 PLL Loss-of-Lock Reset

By programming the LOLRE bit in the ESYNCR2, the PLL can assert reset when a loss-of-lock condition occurs. Because the LOCK and LOCKS bits in the SYNSR are re-initialized after reset, the SIU reset status register described in [Section 3.2.1.2, Reset Status Register \(SIU_RSR\)](#), must be read to determine a loss-of-lock condition occurred.

In PLL Off mode, the PLL cannot lock; therefore a loss-of-lock condition cannot occur and LOLRE has no effect.

6.5.3 PLL Loss-of-Clock Reset

When a loss-of-clock condition is recognized, $\overline{\text{RESET}}$ is asserted if the LOCRE bit in the SYNCR is set. The LOCF and LOC bits in the SYNSR are cleared after reset, therefore, the LOC bit must be read in the SIU_RSR to determine that a loss-of-clock condition occurred. LOCRE has no effect in PLL Off mode.

6.6 Interrupts

This section describes the interrupt requests that the PLL can generate.

6.6.1 Loss-of-Lock Interrupt Request

By setting the LOLIRQ bit in the ESYNCR2, the PLL can request an interrupt when a loss-of-lock condition occurs.

In PLL Off mode, the PLL cannot lock; therefore a loss-of-lock condition cannot occur and the LOLIRQ has no effect.

6.6.2 Loss-of-Clock Interrupt Request

When a loss-of-clock condition is recognized, the PLL requests an interrupt if the LOCIRQ bit in the SYNCR is set. The LOCIRQ bit has no effect in PLL Off mode or if LOCEN is equal to 0.



Chapter 7

System Integration Unit (SIU)

7.1 Introduction

This chapter describes the device system integration unit (SIU) that configures and initializes the following controls:

- MCU reset configuration
- System reset operation
- Pad configuration
- External interrupts
- General-purpose I/O (GPIO)
- Internal peripheral multiplexing
- GPDI and GPDO I/Os of the DSPI modules

7.1.1 Block Diagram

Figure 7-1 is a block diagram of the SIU. The SIU registers are accessed using the crossbar switch.

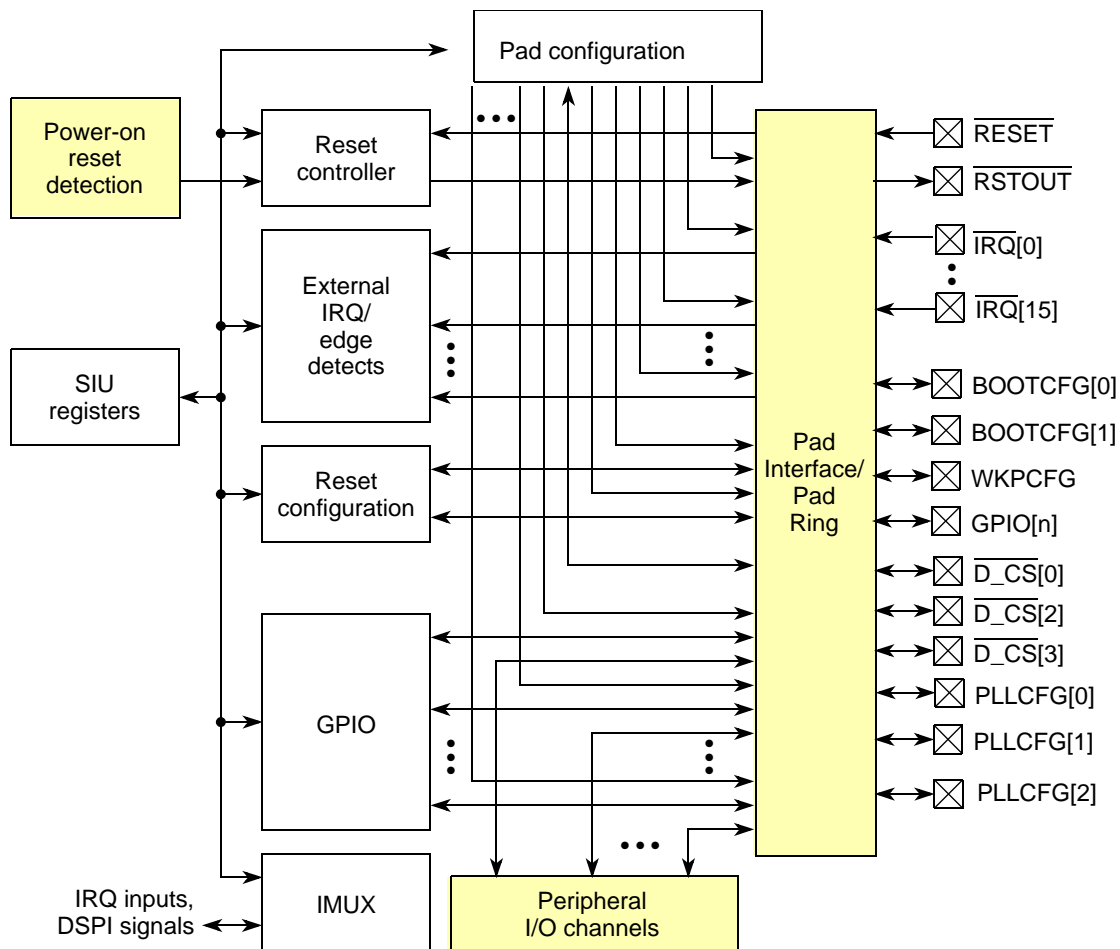

Figure 7-1. SIU Block Diagram

NOTE

The power-on reset detection module, pad interface/pad ring module, and peripheral I/O channels shown shaded in Figure 7-1 are external to the SIU.

7.1.2 Overview

The system integration unit (SIU) is accessed by the core through the system bus crossbar switch (XBAR) and the peripheral bridge A (PBRIDGE_A). [Table 7-1](#) lists the features the SIU configures:

Table 7-1. SIU Features

| Feature | Description |
|----------------------------------|---|
| MCU reset operations | Controls the external pin boot logic |
| System reset operations | Monitors internal and external reset sources, and drives the $\overline{\text{RSTOUT}}$ signal <ul style="list-style-type: none"> • Power-on reset support • Reset status register providing last reset source to software • Glitch detection on reset input • Software controlled reset assertion |
| Pad configuration registers | Enables the configuration and initialization of the I/O pin electrical characteristics using software to select the following: <ul style="list-style-type: none"> • Active function from the set of multiplexed functions • Pullup and pulldown characteristics of the pin • Slew rate for slow and medium pads • Open drain mode for output pins • Hysteresis for input pins • Drive strength of bus signals for fast pads |
| External interrupt operations | <ul style="list-style-type: none"> • 16 interrupt requests • Rising- or falling-edge event detection • Programmable digital filter for glitch rejection • NMI and critical interrupt control |
| General-purpose I/O (GPIO) | Provides uniform and discrete I/O control of MCU general-purpose I/O pins, where each GPIO signal has an input register and an output register. |
| Internal peripheral multiplexing | Provides flexibility to customize signal/pin assignments for application development that allows: <ul style="list-style-type: none"> • Serial and parallel chaining of DSPIs • Flexible selection of eQADC trigger inputs • Assignment of interrupt requests (IRQs) between external pins and DSPI |

7.1.3 Modes of Operation

There are several operating modes for configuring and testing the chip:

Table 7-2. SIU Modes of Operation

| Operating Mode | Description |
|----------------|--|
| Normal | In normal mode, the SIU provides the register interface and logic that controls the device and system configuration, the reset controller, and GPIO. The SIU continues operation with no changes in stop mode. |
| Debug | SIU operation in debug mode is identical to operation in normal mode. |

7.2 External Signal Description

Table 7-3 lists the external pins used by the SIU.

Table 7-3. SIU Signal Properties

| Name | Function | I/O Type |
|---------------------------------|----------------------------------|----------|
| Resets | | |
| $\overline{\text{RESET}}$ | Reset input | Input |
| $\overline{\text{RSTOUT}}$ | Reset output | Output |
| System Configuration | | |
| GPIO_n | General-purpose I/O | I/O |
| $\text{BOOTCFG}[0:1]_-$ | Boot configuration input | Input |
| $\text{IRQ}[2:3]_-$ | Interrupt request | Input |
| $\text{GPIO}[211:212]$ | General-purpose I/O | I/O |
| WKPCFG_- | Weak-pull configuration | Input |
| NMI_- | Non-maskable interrupt to core | Input |
| $\text{GPIO}[213]$ | General-purpose I/O | I/O |
| External Interrupt | | |
| $\overline{\text{IRQ}}[0:15]^1$ | External interrupt request input | Input |

¹ The GPIO and IRQ signals are multiplexed with other functions on the device.

7.2.1 Detailed Signal Descriptions

7.2.1.1 Reset Input ($\overline{\text{RESET}}$)

$\overline{\text{RESET}}$ is an active-low input signal asserted by an external device during a power-on reset (POR) or external reset. $\overline{\text{RESET}}$ assertion for ten clock cycles or more will cause the internal reset. There will be an additional two clock delay from the reset pin change to the event actually taking place. Asserting the $\overline{\text{RESET}}$ signal while the device is processing a reset restarts the reset process at the beginning.

$\overline{\text{RESET}}$ has a glitch detector logic that senses electrical fluctuations on the V_{DDEH} input pins that drop below the switch point value for more than two clock cycles. The switch point value is between the maximum V_{IL} and minimum V_{IH} specifications for the V_{DDEH} input pins.

7.2.1.2 Reset Output ($\overline{\text{RSTOUT}}$)

$\overline{\text{RSTOUT}}$ is an active-low output signal that uses a push/pull configuration. It is driven to the low state by the MCU for all internal and external reset sources. After the $\overline{\text{RESET}}$ input signal negates, $\overline{\text{RSTOUT}}$ asserts for:

- 16000 clock cycles for devices configured in bypass mode
- 2400 clock cycles for all other FMPLL modes

To invoke an external software reset, write a 1 to the system external reset (SER) bit in the system reset control register (SIU_SRCR). This asserts $\overline{\text{RSTOUT}}$ for 2400 clock cycles. An external software reset does not execute the BAM module or sample BOOTCFG[0:1].

7.2.1.3 General-Purpose I/O (GPIO n)

The GPIO signals provide general-purpose input and output functions. GPIO signals are generally multiplexed with other I/O pin functions. Each GPIO input and output is separately controlled by an eight-bit general-purpose data input (SIU_GPDIn) and a general-purpose data output (SIU_GPDO n) register.

The SIU also implements several parallel GPIO registers (SIU_PGPDO x_x and SIU_PGPDI x_x) that can be used to access up to 32 GPIO bits in a single- and word-sized accesses. The values read/written to these parallel registers are coherent with the data read/written to the SIU_GPDO x_x and SIU_GPDI x_x registers

Refer to the following sections for more information:

[Section 7.3.1.14, GPIO Pin Data Output Registers 0–512 \(SIU_GPDO \$n\$ \)](#)

[Section 7.3.1.15, GPIO Pin Data Input Registers 0–255 \(SIU_GPDI \$n\$ \)](#)

7.2.1.4 Boot Configuration (BOOTCFG[0:1])

The BOOTCFG value specifies the location and boot mode used by the boot assist module (BAM). All reset sources can read the boot configuration field, BOOTCFG[0:1], except a debug port reset and a software external reset.

BOOTCFG[0:1] is sampled while processing a reset. The BOOTCFG values are used only while $\overline{\text{RSTOUT}}$ is asserted. Otherwise, the default value for BOOTCFG (0b00) in the reset status register (SIU_RSR) is used, as shown in [Table 7-4](#).

Table 7-4. BOOTCFG Configuration

| BOOTCFG[0] | BOOTCFG[1] | Meaning |
|------------|------------|--|
| 0 | 0 | Boot from internal flash memory (default) |
| 0 | 1 | FlexCAN / eSCI boot |
| 1 | 0 | Boot from external memory (no arbitration) |
| 1 | 1 | Boot from external memory (external arbitration) –EBI not available on all packages |

7.2.1.5 I/O Weak Pullup Reset Configuration (WKPCFG)

The WKPCFG signal is applied when the internal reset signal asserts (indicated by $\overline{\text{RSTOUT}}$ asserting), and is sampled four clock cycles before $\overline{\text{RSTOUT}}$ negates. The WKPCFG value configures the internal weak pullup or weak pulldown pin characteristics after a reset occurs in the eMIOS or eTPU modules.

The value of WKPCFG is latched at reset, stored in the reset status register (SIU_RSR), and updated for all reset sources except the debug port reset and software external reset. The WKPCFG value must be valid and not change until $\overline{\text{RSTOUT}}$ negates.

7.2.1.6 External Interrupt Request Input (IRQ)

$\overline{\text{IRQ}}[0:15]$ The external interrupt request (IRQ) inputs connect to the SIU IRQ inputs. The external IRQ Input Select Register (SIU_EIISR) specifies the $\overline{\text{IRQ}}[0:15]$ signals that are input to the SIU IRQs.

7.3 Memory Map and Register Definition

Table 7-5 is the address map for the SIU registers. All register addresses shown are an offset of the SIU base address.

Table 7-5. SIU Memory Map

| Address | Register | Bits | Access | Reset Value | Section/Page |
|----------------------------|---|------|--------|--|-------------------------------|
| SIU_BASE = 0xC3F9_0000 | Reserved | | | | |
| SIU_BASE + 0x0004 | SIU_MIDR—MCU ID register | 32 | R | 0x5674_6000 Or 0x5674_E000 | 7.3.1.1/7-10 |
| SIU_BASE + 0x0008 | Reserved | | | | |
| SIU_BASE + 0x000C | SIU_RSR—Reset status register | 32 | R/W | 0x8000_U | 7.3.1.2/7-11 |
| SIU_BASE + 0x0010 | SIU_SRCR—System reset control register | 32 | R/W | 0x0000_8000 | 7.3.1.3/7-15 |
| SIU_BASE + 0x0014 | SIU_EISR—SIU external interrupt status register | 32 | R/w1c | 0x0000_0000 | 7.3.1.4/7-15 |
| SIU_BASE + 0x0018 | SIU_DIRER—DMA/interrupt request enable register | 32 | R/W | 0x0000_0000 | 7.3.1.5/7-16 |
| SIU_BASE + 0x001C | SIU_DIRSR—DMA/interrupt request select register | 32 | R/W | 0x0000_0000 | 7.3.1.6/7-17 |
| SIU_BASE + 0x0020 | SIU_OSR—Overrun status register | 32 | R/W | 0x0000_0000 | 7.3.1.7/7-18 |
| SIU_BASE + 0x0024 | SIU_ORER—Overrun request enable register | 32 | R/W | 0x0000_0000 | 7.3.1.8/7-19 |
| SIU_BASE + 0x0028 | SIU_IREER—IRQ rising-edge event enable register | 32 | R/W | 0x0000_0000 | 7.3.1.9/7-20 |
| SIU_BASE + 0x002C | SIU_IFEER—IRQ falling-edge event enable register | 32 | R/W | 0x0000_0000 | 7.3.1.10/7-21 |
| SIU_BASE + 0x0030 | SIU_IDFR—IRQ digital filter register | 32 | R/W | 0x0000_0000 | 7.3.1.11/7-22 |
| SIU_BASE + 0x0034 | SIU_IFIR—IRQ Filtered Input Register | 32 | R/W | 0x0000_0000 | 7.3.1.12/7-22 |
| SIU_BASE + (0x0038–0x003F) | Reserved | | | | |
| SIU_BASE + (0x0040–0x043E) | SIU_PCR0 – SIU_PCR511— Pad configuration registers 0–511 | 16 | R/W | See SIU_PCR _n Settings table for reset values | 7.3.1.13/7-24 |
| SIU_BASE + (0x0440–0x05FF) | Reserved | | | | |
| SIU_BASE + (0x0600–0x07FF) | SIU_GPDO0 – SIU_GPDO511— GPIO pin data output registers 0–511 | 8 | R/W | 0x00 | 7.3.1.14/7-40 |
| SIU_BASE + (0x0800–0x08FF) | SIU_GPDIO0 – SIU_GPDIO255— GPIO input data registers 0–255 (Legacy support only, new implementation at SIU_BASE + 0x0E00) | 8 | R | 0x00 | 7.3.1.15/7-40 |
| SIU_BASE + (0x0900–0x0903) | Reserved | | | | |

Table 7-5. SIU Memory Map (continued)

| Address | Register | Bits | Access | Reset Value | Section/Page |
|----------------------------|---|------|--------|-------------|-------------------------------|
| SIU_BASE + (0x0904–0x0907) | SIU_EIISR (sometimes referred to as ISEL1)—External IRQ input select register | 32 | R/W | 0x0000_0000 | 7.3.1.16/7-41 |
| SIU_BASE + (0x0908–0x090B) | SIU_DISR (sometimes referred to as ISEL2)—DSPI input select register | 32 | R/W | 0x0000_0000 | 7.3.1.17/7-43 |
| SIU_BASE + (0x090C–0x090F) | Reserved | | | | |
| SIU_BASE + (0x0910–0x091F) | SIU_ISEL4–7—eQADC Command FIFO Trigger Source Select—IMUX Select Registers | 32 | R/W | 0x0000_0000 | 7.3.1.18/7-46 |
| SIU_BASE + 0x0920 | SIU_ISEL8—eTPU Input Select Register | 32 | R/W | 0x0000_0000 | 7.3.1.19/7-60 |
| SIU_BASE + 0x0924 | SIU_ISEL9—eQADC Advance Trigger Selection | 32 | R/W | 0x0000_0000 | 7.3.1.20/7-61 |
| SIU_BASE + 0x0928 | SIU_DECFIL1—Decimation Filter Register 1 | 32 | R/W | 0x0000_0000 | 7.3.1.21/7-62 |
| SIU_BASE + 0x092C | SIU_DECFIL2—Decimation Filter Register 2 | 32 | R/W | 0x0000_0000 | 7.3.1.22/7-64 |
| SIU_BASE + (0x0930–0x097F) | Reserved | | | | |
| SIU_BASE + 0x0980 | SIU_CCR—Chip Configuration Register | 32 | R/W | 0x000X_0000 | 7.3.1.23/7-66 |
| SIU_BASE + 0x0984 | SIU_ECCR—External Clock Control Register | 32 | R/W | 0x0000_1001 | 7.3.1.24/7-67 |
| SIU_BASE + (0x0988–0x098C) | Reserved | | | | |
| SIU_BASE + 0x0990 | SIU_CBRH—Compare B High Register | 32 | R/W | 0x0000_0000 | 7.3.1.25/7-68 |
| SIU_BASE + 0x0994 | SIU_CBRL—Compare B Low Register | 32 | R/W | 0x0000_0000 | 7.3.1.26/7-69 |
| SIU_BASE + (0x0998–0x099F) | Reserved | | | | |
| SIU_BASE + 0x9A0 | SIU_SYSDIV—System Clock Register | 32 | R/W | 0x0000_0010 | 7.3.1.27/7-69 |
| SIU_BASE + 0x9A4 | SIU_HLT—Halt Register | 32 | R/W | 0x0000_0000 | 7.3.1.28/7-70 |
| SIU_BASE + 0x9A8 | SIU_HLTACK—Halt Acknowledge Register | 32 | R/W | 0x0000_0000 | 7.3.1.29/7-71 |
| SIU_BASE + (0x09AC–0x0BFF) | Reserved | | | | |
| SIU_BASE + (0x0C00–0x0C3C) | SIU_PGPDO0–SIU_PGPDO15—Parallel GPIO Pin Data Output Register 0–15 | 32 | R/W | 0x0000_0000 | 7.3.1.30/7-73 |
| SIU_BASE + (0x0C40–0x0C7C) | SIU_PGPDI0 – SIU_PGPDI15—Parallel GPIO Pin Data input Register 0–15 | 32 | R | 0x0000_0000 | 7.3.1.31/7-74 |
| SIU_BASE + (0x0C80–0x0CFC) | SIU_MPGPDO0 – SIU_MPGPDO31—Masked Parallel GPIO Pin Data Output Register 0–31 | 32 | W | 0x0000_0000 | 7.3.1.32/7-75 |

Table 7-5. SIU Memory Map (continued)

| Address | Register | Bits | Access | Reset Value | Section/Page |
|-------------------------------------|---|------|--------|-------------|---------------------------------|
| SIU_BASE+0x0D00 | SIU_DSPIAH—DSPIA GP Mask-Output High Register | 32 | R/W | 0x0000_0000 | 7.3.1.33.1/7-78 |
| SIU_BASE+0x0D04 | SIU_DSPIAL—DSPIA GP Mask-Output Low Register | 32 | R/W | 0x0000_0000 | 7.3.1.33.1/7-78 |
| SIU_BASE+0x0D08 | SIU_DSPIBH—DSPIB GP Mask-Output High Register | 32 | R/W | 0x0000_0000 | 7.3.1.33.1/7-78 |
| SIU_BASE+0x0D0C | SIU_DSPIBL—DSPIB GP Mask-Output Low Register | 32 | R/W | 0x0000_0000 | 7.3.1.33.1/7-78 |
| SIU_BASE+0x0D10 | SIU_DSPICH—DSPIC GP Mask-Output High Register | 32 | R/W | 0x0000_0000 | 7.3.1.33.1/7-78 |
| SIU_BASE+0x0D14 | SIU_DSPICL—DSPIC GP Mask-Output Low Register | 32 | R/W | 0x0000_0000 | 7.3.1.33.1/7-78 |
| SIU_BASE+0x0D18 | SIU_DSPIDH—DSPID GP Mask-Output High Register | 32 | R/W | 0x0000_0000 | 7.3.1.33.1/7-78 |
| SIU_BASE+0x0D1C | SIU_DSPIDL—DSPID GP Mask-Output Low Register | 32 | R/W | 0x0000_0000 | 7.3.1.33.1/7-78 |
| SIU_BASE+0x0D20– SIU_BASE+0x0D3F | Reserved | | | | |
| SIU_BASE+0x0D40 | SIU_ETPUBA—DSPIA eTPUB Select Register | 32 | R/W | 0x0000_0000 | 7.3.1.33.2/7-79 |
| SIU_BASE+0x0D44 | SIU_EMIOA—DSPIA eMIOS Select Register | 32 | R/W | 0x0000_0000 | 7.3.1.33.2/7-79 |
| SIU_BASE+0x0D48 | SIU_DSPIAHLA—DSPIA SIU_DSPIAH/L Select Register | 32 | R/W | 0x0000_0000 | 7.3.1.33.2/7-79 |
| SIU_BASE+0x0D4C– | Reserved | | | | |
| SIU_BASE+0x0D50 | SIU_ETPUAB—DSPIB eTPUA Select Register | 32 | R/W | 0x0000_0000 | 7.3.1.33.3/7-81 |
| SIU_BASE+0x0D54 | SIU_EMIOB—DSPIB eMIOS Select Register | 32 | R/W | 0x0000_0000 | 7.3.1.33.3/7-81 |
| SIU_BASE+0x0D58 | SIU_DSPIBHLB—DSPIB SIU_DSPIBH/L Select Register | 32 | R/W | 0x0000_0000 | 7.3.1.33.3/7-81 |
| SIU_BASE+0x0D5C | Reserved | | | | |
| SIU_BASE+0x0D60 | SIU_ETPUAC—DSPIC eTPUA Select Register | 32 | R/W | 0x0000_0000 | 7.3.1.33.4/7-82 |
| SIU_BASE+0x0D64 | SIU_EMIOA—DSPIC eMIOS Select Register | 32 | R/W | 0x0000_0000 | 7.3.1.33.4/7-82 |
| SIU_BASE+0x0D68 | SIU_DSPICHL—DSPIC SIU_DSPICH/L Select Register | 32 | R/W | 0x0000_0000 | 7.3.1.33.4/7-82 |
| SIU_BASE+0x0D6C | SIU_ETPUBC—DSPIC eTPUB Select Register | 32 | R/W | 0x0000_0000 | 7.3.1.33.4/7-82 |
| SIU_BASE+0x0D70 | SIU_ETPUBD—DSPID eTPUB Select Register | 32 | R/W | 0x0000_0000 | 7.3.1.34/7-84 |

Table 7-5. SIU Memory Map (continued)

| Address | Register | Bits | Access | Reset Value | Section/Page |
|-------------------------------------|---|------|--------|-------------|-------------------------------|
| SIU_BASE+0x0D74 | SIU_EMIOSD—DSPID eMIOS Select Register | 32 | R/W | 0x0000_0000 | 7.3.1.34/7-84 |
| SIU_BASE+0x0D78 | SIU_DSPIDHLD—DSPIC SIU_DSPICH/L Select Register | 32 | R/W | 0x0000_0000 | 7.3.1.34/7-84 |
| SIU_BASE+0x0D7C– SIU_BASE+0x0DFF | Reserved | | | | |
| SIU_BASE+0x0E00– SIU_BASE+0x0FDC | SIU_GPDI0—SIU_GPDI511—GPIO Pin Data Input Register 0–511 | 8 | R | 0x0U | 7.3.1.35/7-86 |

7.3.1 Register Descriptions

7.3.1.1 MCU ID Register (SIU_MIDR)

The SIU_MIDR contains the part identification number and mask revision number specific to the device. The part number is a read-only field that is mask programmed with the part number of the device. The part number changes depending on the module versions contained in a device. The part number does not change for bug fixes or process changes.

The mask number is a read-only field that is mask programmed with the specific mask revision level of the device. The current value applies to revision 0 and is updated for each mask revision.

The MCU ID register is 32 bits. [Figure 7-2](#) shows the MCU ID register values.

The following table describes the MIDR fields:

| | | | | | | | | | | | | | | | | | | |
|----------------------------|---------------------------|----|----|----|----|----|----|---------------|----|----|---------------|----|----|----|----|-------------------|--|--|
| Address: SIU_BASE + 0x0004 | | | | | | | | | | | | | | | | Access: Read Only | | |
| | 0 | 1 | 2 | 3 | 4 | 5 | 6 | 7 | 8 | 9 | 10 | 11 | 12 | 13 | 14 | 15 | | |
| R | PARTNUM | | | | | | | | | | | | | | | | | |
| W | | | | | | | | | | | | | | | | | | |
| PXR40 part number | 0 | 1 | 0 | 1 | 0 | 1 | 1 | 0 | 0 | 1 | 1 | 1 | 0 | 1 | 0 | 0 | | |
| | 16 | 17 | 18 | 19 | 20 | 21 | 22 | 23 | 24 | 25 | 26 | 27 | 28 | 29 | 30 | 31 | | |
| R | PKG | | | 0 | 0 | 0 | 0 | MASKNUM_MAJOR | | | MASKNUM_MINOR | | | | | | | |
| W | | | | | | | | | | | | | | | | | | |
| Default reset values | 416= 0b0110 516=0b1110 | | | 0 | 0 | 0 | 0 | 0b0000 | | | 0b0000 | | | | | | | |

Figure 7-2. PXR40 MCU ID Register (SIU_MIDR)

Table 7-6. SIU_MIDR Bit Field Descriptions

| Field | Description |
|------------------------|---|
| 0–15 PARTNUM | MCU part number. Read-only, mask-programmed part identification number of the MCU. PXR40 reads 0x5674 |
| 16–19 PKG | Package settings. PKG selects the pin package for the device. 0110 Select the 416 package 1110 Select the 516 package All other settings are reserved. |
| 20–23 | Reserved |
| 24–27 MASKNUM_MAJOR | Major revision number of MCU mask. Read-only, mask programmed mask number of the MCU. Reads 0x0 for the initial mask set of the device, and changes sequentially for each mask set. |
| 28–31 MASKNUM_MINOR | Minor revision number of MCU mask. Read-only, mask programmed mask number of the MCU. Reads 0x0 for the initial mask set of the device, and changes sequentially for each mask set. |

7.3.1.2 Reset Status Register (SIU_RSR)

The SIU_RSR contains the sources of the most recent reset, and the state of the configuration pins at reset. Except for a POR request or a software external reset, all reset requests, regardless of priority, are not serviced until the current reset completes.

This register contains one reset status bit for each reset source (see [Table 7-7](#)).

A reset status bit set to 1 indicates a reset request by that source. After the reset status bits are set, they remain set until another reset occurs. Simultaneous reset requests are prioritized. When reset requests with different priorities occur on the same clock cycle, the reset request with the highest priority is serviced and the status bit of only that reset request is set.

The following table lists the reset sources and arbitration priorities:

Table 7-7. Reset Source Priorities

| Reset Source | Priority | Group |
|--|----------|-------|
| <ul style="list-style-type: none"> Power on reset (POR) External reset | Highest | 0 |
| <ul style="list-style-type: none"> Software system reset | Higher | 1 |
| <ul style="list-style-type: none"> Loss-of-clock Loss-of-lock Core Watchdog or Debug Platform Watchdog | Lower | 2 |
| <ul style="list-style-type: none"> Software external reset | Lowest | 3 |

The WKPCFG bit retains the latest value of the WKPCFG signal before reset. The BOOTCFG field retains the latest values of the BOOTCFG[0:1] signals before reset.

Address: SIU_BASE + 0x000C

Access: R/W

| | 0 | 1 | 2 | 3 | 4 | 5 | 6 | 7 | 8 | 9 | 10 | 11 | 12 | 13 | 14 | 15 |
|--------------------|-------------------------|-----|------|------|------|----|-----------|----|----|----|----|----|-----|----------------|------|------|
| R | PORS | ERS | LLRS | LCRS | WDRS | 0 | SWT RS | 0 | 0 | 0 | 0 | 0 | 0 | 0 | SSRS | SERF |
| W | | | | | | | | | | | | | | | | |
| Reset ¹ | 1 | 0 | 0 | 0 | 0 | 0 | 0 | 0 | 0 | 0 | 0 | 0 | 0 | 0 | 0 | 0 |
| | 16 | 17 | 18 | 19 | 20 | 21 | 22 | 23 | 24 | 25 | 26 | 27 | 28 | 29 | 30 | 31 |
| R | WKP CFG ² | 0 | 0 | 0 | 0 | 0 | 0 | 0 | 0 | 0 | 0 | 0 | ABR | BOOTCFG | | RGF |
| W | | | | | | | | | | | | | | | | |
| Reset ¹ | U ² | 0 | 0 | 0 | 0 | 0 | 0 | 0 | 0 | 0 | 0 | 0 | U | U ³ | | 0 |

¹ The reset status register receives the reset values during power-on reset.

² The reset value of the WKPCFG bit is the value on the WKPCFG pin at the time of the last reset.

³ The reset value of the BOOTCFG bits is the value on the BOOTCFG[0:1] pins at the time of the last reset.

Figure 7-3. Reset Status Register (SIU_RSR)

The following table lists and describes the fields of the reset status register:

Table 7-8. SIU_RSR Bit Field Descriptions

| Field | Description |
|--------------|---|
| 0 PORS | Power-on reset status. 0 Another reset source was acknowledged by the reset controller since the last assertion of the power-on reset input. 1 The power-on reset input to the reset controller was asserted and no other reset source was acknowledged since the assertion of the power-on reset input except an external reset. |
| 1 ERS | External reset status. 0 The last reset source acknowledged by the reset controller was <i>not</i> a valid assertion of the $\overline{\text{RESET}}$ pin. 1 The last reset source acknowledged by the reset controller was a valid assertion of the $\overline{\text{RESET}}$ pin. |
| 2 LLRS | Loss-of-lock reset status. 0 The last reset source acknowledged by the reset controller was <i>not</i> a loss-of-PLL lock reset. 1 The last reset source acknowledged by the reset controller was a loss-of-PLL lock reset. |
| 3 LCRS | Loss-of-clock reset status. 0 The last reset source acknowledged by the reset controller was <i>not</i> a loss-of-clock reset. 1 The last reset source acknowledged by the reset controller was a loss-of-clock reset. |
| 4 WDRS | Core Watchdog timer/debug reset status. 0 The last reset source acknowledged by the reset controller was <i>not</i> a watchdog timer or debug reset. 1 The last reset source acknowledged by the reset controller was a watchdog timer or debug reset. |
| 6 SWTRS | Platform software watch dog reset status. 0 The last reset source acknowledged by the reset controller was <i>not</i> a platform software watchdog timer or debug reset. 1 The last reset source acknowledged by the reset controller was a platform software watchdog timer or debug reset. |
| 7–13 | Reserved |
| 14 SSRS | Software system reset status. 0 The last reset source acknowledged by the reset controller was <i>not</i> a software system reset. 1 The last reset source acknowledged by the reset controller was a software system reset. |
| 15 SERF | Software external reset flag. 0 The software external reset input to the reset controller was <i>not</i> asserted, or this bit has been cleared by writing a 1 to it. 1 The software external reset input to the reset controller was asserted while this bit was 0. |
| 16 WKPCFG | Weak pull configuration pin status 0 The WKPCFG pin value latched during the last reset was a <i>logical 0</i> and <i>weak pulldown</i> is the default setting. 1 The WKPCFG pin value latched during the last reset was a <i>logical 1</i> and <i>weak pullup</i> is the default setting. |
| 17–27 | Reserved |
| 28 ABR | Auto Baud Rate 0 Auto Baud Rate Disabled 1 Auto Baud Rate Enabled |

Table 7-8. SIU_RSR Bit Field Descriptions (continued)

| Field | Description |
|------------------|--|
| 29–30 BOOTCFG | Reset configuration pin status. BOOTCFG[0:1] identifies the address of the reset configuration halfword (RCHW) and whether arbitration is used by the boot assist module (BAM). 00 Internal boot mode – lowest address (0x0000_0000) from one of the six LAS fields in internal flash memory. 01 Serial boot mode – lower halfword of the censorship control word. 10 External boot mode – lowest address (0x0000_0000) of external memory as defined by the chip select 0 (D_CS[0]) signal with no external arbitration. 11 External boot mode with external arbitration. |
| 31 RGF | Reset glitch flag. Set by the reset controller when a glitch is detected on the $\overline{\text{RESET}}$ pin. This bit is cleared by the assertion of the power-on reset input to the reset controller, or a write of 1 to the RGF bit. Refer to Section 7.4.2.2, RESET Pin Glitch Detect , for more information on glitch detection. 0 No glitch has been detected on the $\overline{\text{RESET}}$ pin. 1 A glitch has been detected on the $\overline{\text{RESET}}$ pin. |

Except for a POR request or writing a 1 to the software external reset flag (SERF) bit, all reset requests, regardless of priority are not serviced until the current reset completes.

In the following cases, more than one reset bit is set in the reset status register (SIU_RSR):

Table 7-9. Causes That Set Multiple Reset Status Bits

| Case 1 | |
|-----------|---|
| Condition | <ul style="list-style-type: none"> • POR request negates and the device remains in the reset • External reset requested • POR and external reset status bits are set |
| Reason | POR request started the reset sequence, but an external reset request was received before the POR reset sequence ended. |
| Case 2 | |
| Condition | <ul style="list-style-type: none"> • Software external reset requested • SERF flag bit set but no previously set bits in the SIU_RSR are cleared |
| Reason | The SERF flag bit is cleared by writing a 1 (write 1 to clear) to the bit location or when another reset source is asserted. |
| Case 3 | |
| Condition | <ul style="list-style-type: none"> • Loss-of-clock reset requested • Loss-of-lock reset requested • Watchdog reset requested |
| Reason | More than one reset request occurred on the same clock cycle with no reset request by a higher-priority reset source, therefore the status bits for all the requesting resets are set. Refer to Table 7-7 . |

7.3.1.3 System Reset Control Register (SIU_SRCR)

The system reset control register configures whether a software system reset or a software external reset is generated. An software system reset uses an internal system reset. An software external reset asserts $\overline{\text{RSTOUT}}$.

Address: SIU_BASE + 0x0010

Access: R/W

| | 0 | 1 | 2 | 3 | 4 | 5 | 6 | 7 | 8 | 9 | 10 | 11 | 12 | 13 | 14 | 15 |
|-------|------------------|-----------------------|----|----|----|----|----|----|----|----|----|----|----|----|----|----|
| R | 0 | SER | 0 | 0 | 0 | 0 | 0 | 0 | 0 | 0 | 0 | 0 | 0 | 0 | 0 | 0 |
| W | SSR ¹ | see note ² | | | | | | | | | | | | | | |
| Reset | 0 | 0 | 0 | 0 | 0 | 0 | 0 | 0 | 0 | 0 | 0 | 0 | 0 | 0 | 0 | 0 |
| | 16 | 17 | 18 | 19 | 20 | 21 | 22 | 23 | 24 | 25 | 26 | 27 | 28 | 29 | 30 | 31 |
| R | 0 | 0 | 0 | 0 | 0 | 0 | 0 | 0 | 0 | 0 | 0 | 0 | 0 | 0 | 0 | 0 |
| W | | | | | | | | | | | | | | | | |
| Reset | 1 | 0 | 0 | 0 | 0 | 0 | 0 | 0 | 0 | 0 | 0 | 0 | 0 | 0 | 0 | 0 |

¹ The SSR bit always reads 0. A write of 0 to this bit has no effect.

² Write 1 to the SER bit to generate a software external reset. A write of 0 to this bit has no effect. When the reset completes, the SER bit is cleared to 0.

Figure 7-4. System Reset Control Register (SIU_SRCR)

The following table describes the fields in the system reset control register:

Table 7-10. SIU_SRCR Bit Field Descriptions

| Field | Description |
|----------|--|
| 0 SSR | Software system reset. The software system reset is processed as a synchronous reset. Except for a software external reset, the bit automatically clears if any other reset source asserts. 0 No software system reset. 1 Generate an software internal system reset. |
| 1 SER | Software external reset. Used to generate a software external reset. Writing a 1 to this bit asserts $\overline{\text{RSTOUT}}$ for 2400 clocks, and the internal reset is not asserted. The bit automatically clears when the software external reset completes or any other reset source is asserted. After a software external reset has been initiated, $\overline{\text{RSTOUT}}$ negates if this bit is cleared before the 2400 clock period expires. 0 Do not generate a software external reset. 1 Generate a software external reset. |
| 2–31 | Reserved |

7.3.1.4 External Interrupt Status Register (SIU_EISR)

The external interrupt status register is used to record edge-triggered events on the $\overline{\text{IRQ}}[0]–\overline{\text{IRQ}}[15]$ inputs to the SIU and record the critical interrupts NMI and SWT. When an edge-detect enable bit is set in the

SIU_IREER or SIU_IFEER registers for an IRQ and an IRQ edge-event occurs and is detected, the IRQ flag bit is set in the SIU_EISR. The IRQ flag bits are cleared by writing a 1 to the bit. A write of 0 has no effect.

The IRQ flag bit is set regardless of the state of the DMA or interrupt request enable bit in SIU_DIRER. The IRQ flag bit remains set until cleared by software or through the servicing of a DMA or interrupt request.

Address: SIU_BASE + 0x0014

Access: R/w1c

| | | | | | | | | | | | | | | | | |
|-------|-------|-------|-------|-------|-------|-------|------|------|------|------|------|------|------|------|------|------|
| | 0 | 1 | 2 | 3 | 4 | 5 | 6 | 7 | 8 | 9 | 10 | 11 | 12 | 13 | 14 | 15 |
| R | NMI | 0 | 0 | 0 | 0 | 0 | 0 | 0 | 0 | 0 | 0 | 0 | 0 | 0 | 0 | 0 |
| W | w1c | | | | | | | | | | | | | | | |
| Reset | 0 | 0 | 0 | 0 | 0 | 0 | 0 | 0 | 0 | 0 | 0 | 0 | 0 | 0 | 0 | 0 |
| | 16 | 17 | 18 | 19 | 20 | 21 | 22 | 23 | 24 | 25 | 26 | 27 | 28 | 29 | 30 | 31 |
| R | EIF15 | EIF14 | EIF13 | EIF12 | EIF11 | EIF10 | EIF9 | EIF8 | EIF7 | EIF6 | EIF5 | EIF4 | EIF3 | EIF2 | EIF1 | EIF0 |
| W | w1c | w1c | w1c | w1c | w1c | w1c | w1c | w1c | w1c | w1c | w1c | w1c | w1c | w1c | w1c | w1c |
| Reset | 0 | 0 | 0 | 0 | 0 | 0 | 0 | 0 | 0 | 0 | 0 | 0 | 0 | 0 | 0 | 0 |

Figure 7-5. External Interrupt Status Register (SIU_EISR)

The following table describes the fields in the external interrupt status register:

Table 7-11. SIU_EISR Bit Field Descriptions

| Field | Description |
|------------------|--|
| 0 NMI | Non-Maskable Interrupt Flag. This bit is set when a NMI interrupt occurs on the NMI input pin. Cleared by writing a 1. 0 No NMI event has occurred on the NMI input 1 An NMI event has occurred on the NMI input |
| 1–15 | Reserved |
| 16–31 EIF n | External interrupt request flag n . This bit is set when an edge-triggered event occurs on the corresponding $\overline{\text{IRQ}}[n]$ input. Cleared by writing a 1. 0 No edge-triggered event has occurred on the corresponding $\overline{\text{IRQ}}[n]$ input. 1 An edge-triggered event has occurred on the corresponding $\overline{\text{IRQ}}[n]$ input. |

7.3.1.5 DMA/Interrupt Request Enable Register (SIU_DIRER)

The SIU_DIRER asserts a DMA transfer or external interrupt request if the IRQ flag bit is set in the SIU_EISR. The DMA transfer or external interrupt request enable bits (EIRE flags) enable an external interrupt request or DMA transfer request. The SIU uses one interrupt request to the interrupt controller. The EIRE bits determine the external interrupt requests that assert the SIU interrupt request to the interrupt controller.

Address: SIU_BASE + 0x0018

Access: R/W

| | | | | | | | | | | | | | | | | |
|-------|------|------|------|------|------|------|------|------|------|------|------|------|------|------|------|------|
| | 0 | 1 | 2 | 3 | 4 | 5 | 6 | 7 | 8 | 9 | 10 | 11 | 12 | 13 | 14 | 15 |
| R | NMI | 0 | 0 | 0 | 0 | 0 | 0 | 0 | NMI | 0 | 0 | 0 | 0 | 0 | 0 | 0 |
| W | SEL8 | | | | | | | | SEL0 | | | | | | | |
| Reset | 0 | 0 | 0 | 0 | 0 | 0 | 0 | 0 | 0 | 0 | 0 | 0 | 0 | 0 | 0 | 0 |
| | 16 | 17 | 18 | 19 | 20 | 21 | 22 | 23 | 24 | 25 | 26 | 27 | 28 | 29 | 30 | 31 |
| R | EIRE | EIRE | EIRE | EIRE | EIRE | EIRE | EIRE | EIRE | EIRE | EIRE | EIRE | EIRE | EIRE | EIRE | EIRE | EIRE |
| W | 15 | 14 | 13 | 12 | 11 | 10 | 9 | 8 | 7 | 6 | 5 | 4 | 3 | 2 | 1 | 0 |
| Reset | 0 | 0 | 0 | 0 | 0 | 0 | 0 | 0 | 0 | 0 | 0 | 0 | 0 | 0 | 0 | 0 |

Figure 7-6. DMA/Interrupt Request Enable Register (SIU_DIRER)

The following table describes the fields in the DMA interrupt request enable register:

Table 7-12. SIU_DIRER Bit Field Descriptions

| Field | Description |
|-------------------|---|
| 0 NMISEL8 | Non Maskable Interrupt / Critical Interrupt Selection (NMI comes from external pin). SIU generates two specific sources of interrupt to the core, one of them is defined as critical interrupt and the other is defined as non maskable interrupt (NMI). The NMISEL bit selects which signal receives the IRQ from the pin. 0 NMI is enabled (IVOR1 core exception) 1 Critical interrupt is enabled (IVOR0 core exception) Note: NMISEL8 is a write once bit. |
| 1–7 | Reserved |
| 8 NMISEL0 | Non Maskable Interrupt / Critical Interrupt Selection (NMI comes from watchdog timer, SWT). SIU generates two specific sources of interrupt to the core, one of them is defined as critical interrupt and the other is defined as non maskable interrupt (NMI). 0 NMI is enabled (IVOR1 core exception) 1 Critical interrupt is enabled (IVOR0 core exception) Note: NMISEL0 is a write once bit. |
| 9–15 | Reserved |
| 16–31 EIRE n | External interrupt request enable n . Enables the assertion of the interrupt request from the SIU to the interrupt controller when an edge-triggered event occurs on the $\overline{IRQ}[n]$ pin. 0 External interrupt request is disabled. 1 External interrupt request is enabled. Note: EIRE[0:3] can optionally enable DMA requests instead of IRQs. |

7.3.1.6 DMA/Interrupt Request Select Register (SIU_DIRSR)

The SIU_DIRSR selects between a DMA or interrupt request for events on the $\overline{IRQ}[0]–\overline{IRQ}[3]$ inputs. If the IRQ flag bits are set in the external IRQ status register (SIU_EISR) and the DMA/interrupt request enable register (SIU_DIRER), then the select bit in the DMA interrupt request select register (SIU_DIRSR) determines whether a DMA or interrupt request is asserted.

System Integration Unit (SIU)

Address: SIU_BASE + 0x001C

Access: R/W

| | | | | | | | | | | | | | | | | |
|-------|----|----|----|----|----|----|----|----|----|----|----|----|------|------|------|------|
| | 0 | 1 | 2 | 3 | 4 | 5 | 6 | 7 | 8 | 9 | 10 | 11 | 12 | 13 | 14 | 15 |
| R | 0 | 0 | 0 | 0 | 0 | 0 | 0 | 0 | 0 | 0 | 0 | 0 | 0 | 0 | 0 | 0 |
| W | | | | | | | | | | | | | | | | |
| Reset | 0 | 0 | 0 | 0 | 0 | 0 | 0 | 0 | 0 | 0 | 0 | 0 | 0 | 0 | 0 | 0 |
| | 16 | 17 | 18 | 19 | 20 | 21 | 22 | 23 | 24 | 25 | 26 | 27 | 28 | 29 | 30 | 31 |
| R | 0 | 0 | 0 | 0 | 0 | 0 | 0 | 0 | 0 | 0 | 0 | 0 | DIRS | DIRS | DIRS | DIRS |
| W | | | | | | | | | | | | | 3 | 2 | 1 | 0 |
| Reset | 0 | 0 | 0 | 0 | 0 | 0 | 0 | 0 | 0 | 0 | 0 | 0 | 0 | 0 | 0 | 0 |

Figure 7-7. DMA/Interrupt Request Select Register (SIU_DIRSR)

The following table describes the fields of the request select register:

Table 7-13. SIU_DIRSR Bit Field Descriptions

| Field | Description |
|-------------------|--|
| 0–27 | Reserved |
| 28–31 DIRS n | DMA interrupt request select n . Selects between a DMA transfer or external interrupt request when an edge-triggered event occurs on the corresponding $\overline{\text{IRQ}}[n]$ pin. 0 Interrupt request is selected. 1 DMA request is selected. |

7.3.1.7 Overrun Status Register (SIU_OSR)

The SIU_OSR flag bits indicate that an overrun has occurred.

Address: SIU_BASE + 0x0020

Access: R/W

| | | | | | | | | | | | | | | | | |
|-------|-----|-----|-----|-----|-----|-----|-----|-----|-----|-----|-----|-----|-----|-----|-----|-----|
| | 0 | 1 | 2 | 3 | 4 | 5 | 6 | 7 | 8 | 9 | 10 | 11 | 12 | 13 | 14 | 15 |
| R | 0 | 0 | 0 | 0 | 0 | 0 | 0 | 0 | 0 | 0 | 0 | 0 | 0 | 0 | 0 | 0 |
| W | | | | | | | | | | | | | | | | |
| Reset | 0 | 0 | 0 | 0 | 0 | 0 | 0 | 0 | 0 | 0 | 0 | 0 | 0 | 0 | 0 | 0 |
| | 16 | 17 | 18 | 19 | 20 | 21 | 22 | 23 | 24 | 25 | 26 | 27 | 28 | 29 | 30 | 31 |
| R | OVF | OVF | OVF | OVF | OVF | OVF | OVF | OVF | OVF | OVF | OVF | OVF | OVF | OVF | OVF | OVF |
| W | 15 | 14 | 13 | 12 | 11 | 10 | 9 | 8 | 7 | 6 | 5 | 4 | 3 | 2 | 1 | 0 |
| Reset | 0 | 0 | 0 | 0 | 0 | 0 | 0 | 0 | 0 | 0 | 0 | 0 | 0 | 0 | 0 | 0 |

Figure 7-8. Overrun Status Register (SIU_OSR)

The following table describes the fields in the overrun status register:

Table 7-14. SIU_OSР Bit Field Descriptions

| Field | Description |
|------------------|---|
| 0–15 | Reserved |
| 16–31 OVF n | Overrun flag n . This bit is set when an overrun occurs on $\overline{\text{IRQ}}[n]$. Bit 31 (OVF0) is the overrun flag for $\overline{\text{IRQ}}[0]$; bit 16 (OVF15) is overrun flag for $\overline{\text{IRQ}}[15]$. 0 No overrun occurred. 1 An overrun occurred. |

7.3.1.8 Overrun Request Enable Register (SIU_ORER)

The SIU_ORER contains bits to enable an overrun if the corresponding flag bit is set in the SIU_OSР. If the overrun request enable bit and the flag bit are set, the single combined overrun request from the SIU to the interrupt controller is asserted.

Address: SIU_BASE + 0x0024

Access: R/W

| | | | | | | | | | | | | | | | | |
|-------|-----------|-----------|-----------|-----------|-----------|-----------|----------|----------|----------|----------|----------|----------|----------|----------|----------|----------|
| | 0 | 1 | 2 | 3 | 4 | 5 | 6 | 7 | 8 | 9 | 10 | 11 | 12 | 13 | 14 | 15 |
| R | 0 | 0 | 0 | 0 | 0 | 0 | 0 | 0 | 0 | 0 | 0 | 0 | 0 | 0 | 0 | 0 |
| W | | | | | | | | | | | | | | | | |
| Reset | 0 | 0 | 0 | 0 | 0 | 0 | 0 | 0 | 0 | 0 | 0 | 0 | 0 | 0 | 0 | 0 |
| | 16 | 17 | 18 | 19 | 20 | 21 | 22 | 23 | 24 | 25 | 26 | 27 | 28 | 29 | 30 | 31 |
| R | ORE 15 | ORE 14 | ORE 13 | ORE 12 | ORE 11 | ORE 10 | ORE 9 | ORE 8 | ORE 7 | ORE 6 | ORE 5 | ORE 4 | ORE 3 | ORE 2 | ORE 1 | ORE 0 |
| W | | | | | | | | | | | | | | | | |
| Reset | 0 | 0 | 0 | 0 | 0 | 0 | 0 | 0 | 0 | 0 | 0 | 0 | 0 | 0 | 0 | 0 |

Figure 7-9. Overrun Request Enable Register (SIU_ORER)

The following table describes the fields in the overrun request enable register:

Table 7-15. SIU_ORER Bit Field Descriptions

| Field | Function |
|------------------|--|
| 0–15 | Reserved |
| 16–31 ORE n | Overrun request enable n . Enables the overrun request when an overrun occurs on the $\overline{\text{IRQ}}[n]$ pin. Bit 31 (ORE0) is the enable overrun flag for $\overline{\text{IRQ}}[0]$; bit 16 (ORE15) is overrun flag for $\overline{\text{IRQ}}[15]$. 0 Overrun request is disabled. 1 Overrun request is enabled. |

7.3.1.9 IRQ Rising-Edge Event Enable Register (SIU_IREER)

The SIU_IREER enables rising edge-triggered events on $\overline{\text{IRQ}}[n]$. Rising- and falling-edge events are enabled by setting the bits in SIU_IREER and SIU_IFEER.

SIU_IREER bits used for NMI events are write once and another write will be allowed after a reset.

Address: SIU_BASE + 0x0028

Access: R/W

| | | | | | | | | | | | | | | | | | |
|-------|-----------|---------|---------|---------|---------|---------|-------|-------|-------|-------|-------|-------|-------|-------|-------|-------|----|
| | | 0 | 1 | 2 | 3 | 4 | 5 | 6 | 7 | 8 | 9 | 10 | 11 | 12 | 13 | 14 | 15 |
| R | IREE_NMI8 | 0 | 0 | 0 | 0 | 0 | 0 | 0 | 0 | 0 | 0 | 0 | 0 | 0 | 0 | 0 | 0 |
| W | | | | | | | | | | | | | | | | | |
| Reset | | 0 | 0 | 0 | 0 | 0 | 0 | 0 | 0 | 0 | 0 | 0 | 0 | 0 | 0 | 0 | 0 |
| | | 16 | 17 | 18 | 19 | 20 | 21 | 22 | 23 | 24 | 25 | 26 | 27 | 28 | 29 | 30 | 31 |
| R | IREE 15 | IREE 14 | IREE 13 | IREE 12 | IREE 11 | IREE 10 | IREE9 | IREE8 | IREE7 | IREE6 | IREE5 | IREE4 | IREE3 | IREE2 | IREE1 | IREE0 | |
| W | | | | | | | | | | | | | | | | | |
| Reset | | 0 | 0 | 0 | 0 | 0 | 0 | 0 | 0 | 0 | 0 | 0 | 0 | 0 | 0 | 0 | 0 |

Figure 7-10. IRQ Rising-Edge Event Enable Register (SIU_IREER)

The following table describes the fields in the IRQ rising-edge event enable register:

Table 7-16. SIU_IREER Bit Field Descriptions

| Field | Function |
|----------------|--|
| 0 IREE_NMI8 | IRQ rising-edge event enable for NMI from external NMI pin. 0 Rising-edge event is disabled. 1 Rising-edge event is enabled. |
| 1–15 | Reserved |
| 16–0 IREEn | IRQ rising-edge event enable <i>n</i> . Enables rising-edge-triggered events on the corresponding $\overline{\text{IRQ}}[n]$ pin. 0 Rising-edge event is disabled. 1 Rising-edge event is enabled. |

7.3.1.10 IRQ Falling-Edge Event Enable Register (SIU_IFEER)

The SIU_IFEER enables falling edge-triggered events on $\overline{\text{IRQ}}[n]$. Rising- and falling-edge events are enabled by setting the bits in both SIU_IREER and SIU_IFEER.

SIU_IFEER bits used for NMI events are write once and another write will be allowed after a reset.

Address: SIU_BASE + 0x002C

Access: R/W

| | | | | | | | | | | | | | | | | |
|-------|-----------|---------|---------|---------|---------|---------|--------|--------|--------|--------|--------|--------|--------|--------|--------|--------|
| | 0 | 1 | 2 | 3 | 4 | 5 | 6 | 7 | 8 | 9 | 10 | 11 | 12 | 13 | 14 | 15 |
| R | IFEE_NMI8 | 0 | 0 | 0 | 0 | 0 | 0 | 0 | 0 | 0 | 0 | 0 | 0 | 0 | 0 | 0 |
| W | | | | | | | | | | | | | | | | |
| Reset | 0 | 0 | 0 | 0 | 0 | 0 | 0 | 0 | 0 | 0 | 0 | 0 | 0 | 0 | 0 | 0 |
| | 16 | 17 | 18 | 19 | 20 | 21 | 22 | 23 | 24 | 25 | 26 | 27 | 28 | 29 | 30 | 31 |
| R | IFEE_15 | IFEE_14 | IFEE_13 | IFEE_12 | IFEE_11 | IFEE_10 | IFEE_9 | IFEE_8 | IFEE_7 | IFEE_6 | IFEE_5 | IFEE_4 | IFEE_3 | IFEE_2 | IFEE_1 | IFEE_0 |
| W | | | | | | | | | | | | | | | | |
| Reset | 0 | 0 | 0 | 0 | 0 | 0 | 0 | 0 | 0 | 0 | 0 | 0 | 0 | 0 | 0 | 0 |

Figure 7-11. IRQ Falling-Edge Event Enable Register (SIU_IFEER)

The following table describes the fields in the IRQ falling-edge event enable register:

Table 7-17. SIU_IFEER Bit Field Descriptions

| Field | Function |
|------------------|---|
| 0 IFEE_NMI8 | IRQ rising-edge event enable for NMI from external NMI pin. 0 Rising-edge event is disabled. 1 Rising-edge event is enabled. |
| 1–15 | Reserved |
| 16–0 IFEE n | IRQ falling-edge event enable n . Enables falling-edge-triggered events on the corresponding $\overline{\text{IRQ}}[n]$ pin. 0 Falling-edge event is disabled. 1 Falling-edge event is enabled. |

7.3.1.11 IRQ Digital Filter Register (SIU_IDFR)

The SIU_IDFR specifies the amount of digital filtering on $\overline{\text{IRQ}}[0]–\overline{\text{IRQ}}[15]$. The digital filter length field specifies the number of system clocks that define the period of the digital filter and the minimum time an IRQ signal must hold the active state to qualify as an edge-triggered event.

Address: SIU_BASE + 0x0030

Access: R/W

| | | | | | | | | | | | | | | | | |
|-------|----|----|----|----|----|----|----|----|----|----|----|----|-----|----|----|----|
| | 0 | 1 | 2 | 3 | 4 | 5 | 6 | 7 | 8 | 9 | 10 | 11 | 12 | 13 | 14 | 15 |
| R | 0 | 0 | 0 | 0 | 0 | 0 | 0 | 0 | 0 | 0 | 0 | 0 | 0 | 0 | 0 | 0 |
| W | | | | | | | | | | | | | | | | |
| Reset | 0 | 0 | 0 | 0 | 0 | 0 | 0 | 0 | 0 | 0 | 0 | 0 | 0 | 0 | 0 | 0 |
| | 16 | 17 | 18 | 19 | 20 | 21 | 22 | 23 | 24 | 25 | 26 | 27 | 28 | 29 | 30 | 31 |
| R | 0 | 0 | 0 | 0 | 0 | 0 | 0 | 0 | 0 | 0 | 0 | 0 | DFL | | | |
| W | | | | | | | | | | | | | | | | |
| Reset | 0 | 0 | 0 | 0 | 0 | 0 | 0 | 0 | 0 | 0 | 0 | 0 | 0 | 0 | 0 | 0 |

Figure 7-12. IRQ Digital Filter Register (SIU_IDFR)

The following table describes the field in the IRQ digital filter register:

Table 7-18. SIU_IDFR Bit Field Descriptions

| Field | Function |
|--------------|---|
| 0–27 | Reserved |
| 28–31 DFL | <p>Digital filter length. Defines the digital filter period on the $\overline{\text{IRQ}}[n]$ inputs according to the following equation:</p> $\text{Filter Period} = (\text{SystemClockPeriod} \times 2^{\text{DFL}}) + 1(\text{SystemClockPeriod})$ <p>For a 100 MHz system clock, this gives a range of 20 ns to 328 μs. The minimum time of three clocks accounts for synchronization of the IRQ input pins with the system clock.</p> |

7.3.1.12 IRQ Filtered Input Register (SIU_IFIR)

The SIU_IFIR is a read only register where the filtered values of the NMI and $\overline{\text{IRQ}}[0]–\overline{\text{IRQ}}[15]$ pins are captured.

Address: SIU_BASE + 0x0034

Access: Read Only

| | | | | | | | | | | | | | | | | |
|-------|------|------|------|------|------|------|-----|-----|-----|-----|-----|-----|-----|-----|-----|-----|
| | 0 | 1 | 2 | 3 | 4 | 5 | 6 | 7 | 8 | 9 | 10 | 11 | 12 | 13 | 14 | 15 |
| R | IFL | 0 | 0 | 0 | 0 | 0 | 0 | 0 | 0 | 0 | 0 | 0 | 0 | 0 | 0 | 0 |
| W | NMI | | | | | | | | | | | | | | | |
| Reset | | 0 | 0 | 0 | 0 | 0 | 0 | 0 | 0 | 0 | 0 | 0 | 0 | 0 | 0 | 0 |
| | 16 | 17 | 18 | 19 | 20 | 21 | 22 | 23 | 24 | 25 | 26 | 27 | 28 | 29 | 30 | 31 |
| R | IF15 | IF14 | IF13 | IF12 | IF11 | IF10 | IF9 | IF8 | IF7 | IF6 | IF5 | IF4 | IF3 | IF2 | IF1 | IF0 |
| W | | | | | | | | | | | | | | | | |
| Reset | | 0 | 0 | 0 | 0 | 0 | 0 | 0 | 0 | 0 | 0 | 0 | 0 | 0 | 0 | 0 |

Figure 7-13. IRQ Filtered Input Register (SIU_IFIR)

Table 7-19. SIU_IFIR Bit Field Descriptions

| Field | Function |
|--------------|---|
| 0–31 IFIn | Filtered Input n—set/cleared for the corresponding filtered IRQ pin. 0 A logic zero has passed through the IRQ digital filter for the corresponding IRQ pin. 1 A logic one has passed through the IRQ digital filter for the corresponding IRQ pin. |

7.3.1.13 Pad Configuration Registers (SIU_PCR)

The following subsections define pad configuration registers (PCR) in the SIU_PCR segment. These registers define the pad configuration for all configurable device pins that specify that active function, direction, and electrical attributes for the pin. The information presented pertains to which bits and fields are active for a given pin or group of pins, and the reset state of the register.

The reset state of SIU_PCRs given in this section is the value before the BAM program executes. The BAM program can change some pad configuration registers based on the reset configuration. Refer to the BAM chapter for more detailed information.

The SIU_PCRs are 16-bit registers that are read from or written to as:

- 16-bit values aligned on 16-bit boundaries, or
- 32-bit values aligned on 32-bit address boundaries.

NOTE

The fields available in a SIU_PCR depend on the type of pad it controls. Refer to the SIU_PCR definition.

All device pin names begin with the primary function, followed by the alternate function, and then GPIO. In some cases, the third function can be a secondary alternate, which supersedes the GPIO. Those exceptions are noted in the documentation. For example, SIU_PCR85 configures the CNTXB_PCSC[3]_GPIO[85] muxed signal, where CNTXB is the primary function, PCSC[3] is the alternate function. For identification of the source module for primary and alternate functions, and the description of these signals, refer to [Chapter 3, Signal Descriptions](#), of this manual. Refer to the chapter for the specific module that uses the signal for an additional signal description.

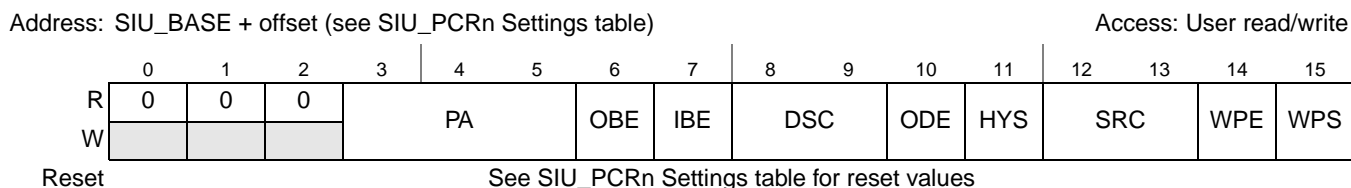

Figure 7-14. Pad Configuration Register (SIU_PCRn)

The following table describes the fields in the pad configuration control registers:

Table 7-20. SIU_PCR Bit Field Descriptions

| Field | Description | | | | | | | | | | | | | | | | | | | | | | | | | | | | | | | | | | | | |
|-------------|--|----|---------------------------|--|---------------------------|---|---|---|------|---|---|---|------------------|---|---|---|-------------|---|---|---|-------------|---|---|---|-------------|---|---|---|---------------|---|---|---|---------------|---|---|---|---------------|
| 0–2 | Reserved | | | | | | | | | | | | | | | | | | | | | | | | | | | | | | | | | | | | |
| 3–5 PA[| <p>Pin assignment. Selects the function of a multiplexed pad. A separate port enable output signal from the SIU is asserted for each value of this register. The size of the field can be from 1 to 3 bits, depending on the amount of multiplexing on the pad.</p> <table border="1" style="margin-left: auto; margin-right: auto;"> <thead> <tr> <th colspan="3">PA</th> <th>Pin Function ¹</th> </tr> </thead> <tbody> <tr> <td>0</td> <td>0</td> <td>0</td> <td>GPIO</td> </tr> <tr> <td>0</td> <td>0</td> <td>1</td> <td>Primary function</td> </tr> <tr> <td>0</td> <td>1</td> <td>0</td> <td>Alternate 1</td> </tr> <tr> <td>0</td> <td>1</td> <td>1</td> <td>Alternate 2</td> </tr> <tr> <td>1</td> <td>0</td> <td>0</td> <td>Alternate 3</td> </tr> <tr> <td>1</td> <td>0</td> <td>1</td> <td>Invalid value</td> </tr> <tr> <td>1</td> <td>1</td> <td>0</td> <td>Invalid value</td> </tr> <tr> <td>1</td> <td>1</td> <td>1</td> <td>Invalid value</td> </tr> </tbody> </table> <p>¹ For any SIU_PCR that does not comply with these rules, the PA definition is given explicitly with the SIU_PCR definition.</p> | PA | | | Pin Function ¹ | 0 | 0 | 0 | GPIO | 0 | 0 | 1 | Primary function | 0 | 1 | 0 | Alternate 1 | 0 | 1 | 1 | Alternate 2 | 1 | 0 | 0 | Alternate 3 | 1 | 0 | 1 | Invalid value | 1 | 1 | 0 | Invalid value | 1 | 1 | 1 | Invalid value |
| PA | | | Pin Function ¹ | | | | | | | | | | | | | | | | | | | | | | | | | | | | | | | | | | |
| 0 | 0 | 0 | GPIO | | | | | | | | | | | | | | | | | | | | | | | | | | | | | | | | | | |
| 0 | 0 | 1 | Primary function | | | | | | | | | | | | | | | | | | | | | | | | | | | | | | | | | | |
| 0 | 1 | 0 | Alternate 1 | | | | | | | | | | | | | | | | | | | | | | | | | | | | | | | | | | |
| 0 | 1 | 1 | Alternate 2 | | | | | | | | | | | | | | | | | | | | | | | | | | | | | | | | | | |
| 1 | 0 | 0 | Alternate 3 | | | | | | | | | | | | | | | | | | | | | | | | | | | | | | | | | | |
| 1 | 0 | 1 | Invalid value | | | | | | | | | | | | | | | | | | | | | | | | | | | | | | | | | | |
| 1 | 1 | 0 | Invalid value | | | | | | | | | | | | | | | | | | | | | | | | | | | | | | | | | | |
| 1 | 1 | 1 | Invalid value | | | | | | | | | | | | | | | | | | | | | | | | | | | | | | | | | | |
| 6 OBE | <p>Output buffer enable. Enables the pad as an output and drives the output buffer enable signal.</p> <p>0 Disable output buffer for the pad. 1 Enable output buffer for the pad is enabled.</p> | | | | | | | | | | | | | | | | | | | | | | | | | | | | | | | | | | | | |
| 7 IBE | <p>Input buffer enable. Enables the pad as an input and drives the input buffer enable signal.</p> <p>0 Disable input buffer for the pad. 1 Enable input buffer for the pad is enabled.</p> | | | | | | | | | | | | | | | | | | | | | | | | | | | | | | | | | | | | |
| 8–9 DSC[| <p>Drive strength control. Controls the pad drive strength. Drive strength control pertains to pins with the fast I/O pad type.</p> <p>00 10 pF drive strength 01 20 pF drive strength 10 30 pF drive strength 11 50 pF drive strength</p> | | | | | | | | | | | | | | | | | | | | | | | | | | | | | | | | | | | | |
| 10 ODE | <p>Open drain output enable. Controls output driver configuration for the pads. Either open drain or push/pull driver configurations can be selected. This feature applies to output pins only.</p> <p>0 Disable open drain for the pad (push/pull driver enabled). 1 Enable open drain for the pad.</p> | | | | | | | | | | | | | | | | | | | | | | | | | | | | | | | | | | | | |
| 11 HYS | <p>Input hysteresis. Controls whether hysteresis is enabled for the pad.</p> <p>0 Disable hysteresis for the pad. 1 Enable hysteresis for the pad.</p> | | | | | | | | | | | | | | | | | | | | | | | | | | | | | | | | | | | | |

Table 7-20. SIU_PCR Bit Field Descriptions (continued)

| Field | Description |
|---------------|---|
| 12–13 SRC[| Slew rate control. Controls slew rate for the pad. Slew rate control pertains to pins with slow or medium I/O pad types, and the output signals are driven according to the value of this field. Actual slew rate depends on the pad type and load. Refer to the electrical specifications for this information. 00 Minimum slew rate 01 Medium slew rate 10 Invalid value 11 Maximum slew rate |
| 14 WPE | Weak pullup/down enable. Controls whether the weak pullup/down devices are enabled/disabled for the pad. Pullup/down devices are enabled by default. 0 Disable weak pull device for the pad. 1 Enable weak pull device for the pad. |
| 15 WPS | Weak pullup/down select. Controls whether weak pullup or weak pulldown devices are used for the pad when weak pullup/down devices are enabled. The WKPCFG pin determines whether pullup or pulldown devices are enabled during reset. The WPS bit determines whether weak pullup or pulldown devices are used after reset, or for pads in which the WKPCFG pin does not determine the reset weak pullup/down state. 0 Pulldown is enabled for the pad. 1 Pullup is enabled for the pad. |

There are a number of input signals on the device that have multiple external pins as input sources. Only one input source can be active at any time for these pins. To achieve this, there is a pre-defined priority for the PCR registers controlling these pins, which is used to mux the input sources and allow only one active input. The multiple source inputs with PCR priority is given in [Table 7-21](#).

Table 7-21. PCR priority for multiple source inputs

| Function | PCR number | | |
|----------|------------------|-----|-----------------|
| | highest priority | → | lowest priority |
| IRQ0 | 193 | 450 | — |
| IRQ1 | 194 | 451 | — |
| IRQ2 | 211 | 452 | — |
| IRQ3 | 212 | 453 | — |
| IRQ4 | 208 | 454 | — |
| IRQ5 | 209 | 455 | — |
| PCSB0 | 105 | 203 | — |
| SCKC | 235 | 109 | — |
| SINC | 236 | 108 | — |
| PCSC0 | 238 | 110 | 434 |
| SCKD | 189 | 470 | — |
| SIND | 190 | 472 | — |
| PCSD0 | 106 | 469 | — |
| CANRXD | 247 | 194 | — |
| TXDA | 89 | 83 | 460 |
| RXDA | 90 | 84 | 461 |
| TXDB | 91 | 462 | — |
| RXDB | 92 | 463 | — |
| FR_RX_A | 249 | 458 | — |

Table 7-22. SIU_PCRn Settings

| PCRn | Address Offset | GPIO | Primary Function | A2 | A3 | A4 | SIU_PCRn[3:15] ¹ | | | | | | | | | | | | | | |
|-----------------|----------------|---------------------|------------------|-------------------|------|------|---|-----|------|------|-----|-----|---|----|----|----|----|----|----|---|--|
| | | | | | | | (SIU_PCRn[0:2] = Reserved, should be cleared) | | | | | | | | | | | | | | |
| | | | | | | | 3 | 4 | 5 | 6 | 7 | 8 | 9 | 10 | 11 | 12 | 13 | 14 | 15 | | |
| PA2 | PA1 | PA0 | OBE | IBE | DSC1 | DSC0 | ODE | HYS | SRC1 | SRC0 | WPE | WPS | | | | | | | | | |
| 75 ² | 0x00D6 | GPIO75 ³ | MDO4 | — | — | — | — | — | — | 0 | 0 | 1 | 1 | — | — | — | — | — | — | | |
| 76 ² | 0x00D8 | GPIO76 ³ | MDO5 | — | — | — | — | — | — | 0 | 0 | 1 | 1 | — | — | — | — | — | — | | |
| 77 ² | 0x00DA | GPIO77 ³ | MDO6 | — | — | — | — | — | — | 0 | 0 | 1 | 1 | — | — | — | — | — | — | | |
| 78 ² | 0x00DC | GPIO78 ³ | MDO7 | — | — | — | — | — | — | 0 | 0 | 1 | 1 | — | — | — | — | — | — | | |
| 79 ² | 0x00DE | GPIO79 ³ | MDO8 | — | — | — | — | — | — | 0 | 0 | 1 | 1 | — | — | — | — | — | — | | |
| 80 ² | 0x00E0 | GPIO80 ³ | MDO9 | — | — | — | — | — | — | 0 | 0 | 1 | 1 | — | — | — | — | — | — | | |
| 81 ² | 0x00E2 | GPIO81 ³ | MDO10 | — | — | — | — | — | — | 0 | 0 | 1 | 1 | — | — | — | — | — | — | | |
| 82 ² | 0x00E4 | GPIO82 ³ | MDO11 | — | — | — | — | — | — | 0 | 0 | 1 | 1 | — | — | — | — | — | — | | |
| 83 | 0x00E6 | GPIO83 | CNTXA | TXDA ⁴ | — | — | — | — | 0 | 0 | 0 | 0 | — | — | 0 | 0 | 0 | 0 | 1 | 1 | |
| 84 | 0x00E8 | GPIO84 | CNRXA | RXDA ⁴ | — | — | — | — | 0 | 0 | 0 | 0 | — | — | 0 | 0 | 0 | 0 | 1 | 1 | |
| 85 | 0x00EA | GPIO85 | CNTXB | PCSC3 | — | — | — | — | 0 | 0 | 0 | 0 | — | — | 0 | 0 | 0 | 0 | 1 | 1 | |
| 86 | 0x00EC | GPIO86 | CNRXB | PCSC4 | — | — | — | — | 0 | 0 | 0 | 0 | — | — | 0 | 0 | 0 | 0 | 1 | 1 | |
| 87 | 0x00EE | GPIO87 | CNTXC | PCSD3 | — | — | — | — | 0 | 0 | 0 | 0 | — | — | 0 | 0 | 0 | 0 | 1 | 1 | |
| 88 | 0x00F0 | GPIO88 | CNRXC | PCSD4 | — | — | — | — | 0 | 0 | 0 | 0 | — | — | 0 | 0 | 0 | 0 | 1 | 1 | |
| 89 | 0x00F2 | GPIO89 | TXDA | — | — | — | — | — | 0 | 0 | 0 | 0 | — | — | 0 | 0 | 0 | 0 | 1 | 1 | |
| 90 | 0x00F4 | GPIO90 | RXDA | — | — | — | — | — | 0 | 0 | 0 | 0 | — | — | 0 | 0 | 0 | 0 | 1 | 1 | |
| 91 | 0x00F6 | GPIO91 | TXDB | PCSD1 | — | — | — | — | 0 | 0 | 0 | 0 | — | — | 0 | 0 | 0 | 0 | 1 | 1 | |
| 92 | 0x00F8 | GPIO92 | RXDB | PCSD5 | — | — | — | — | 0 | 0 | 0 | 0 | — | — | 0 | 0 | 0 | 0 | 1 | 1 | |
| 93 | 0x00FA | GPIO93 | SCKA | PCSC1 | — | — | — | — | 0 | 0 | 0 | 0 | — | — | 0 | 0 | 0 | 0 | 1 | 1 | |
| 94 | 0x00FC | GPIO94 | SINA | PCSC2 | — | — | — | — | 0 | 0 | 0 | 0 | — | — | 0 | 0 | 0 | 0 | 1 | 1 | |
| 95 | 0x00FE | GPIO95 | SOUTA | PCSC5 | — | — | — | — | 0 | 0 | 0 | 0 | — | — | 0 | 0 | 0 | 0 | 1 | 1 | |
| 96 | 0x0100 | GPIO96 | PCSA0 | PCSD2 | — | — | — | — | 0 | 0 | 0 | 0 | — | — | 0 | 0 | 0 | 0 | 1 | 1 | |

Table 7-22. SIU_PCRn Settings (continued)

| PCRn | Address Offset | GPIO | Primary Function | A2 | A3 | A4 | SIU_PCRn[3:15] ¹ | | | | | | | | | | | | | | |
|------|----------------|---------|------------------|--------------------|------|------|---|-----|------|------|-----|-----|---|----|----|----|----|----|----|--|--|
| | | | | | | | (SIU_PCRn[0:2] = Reserved, should be cleared) | | | | | | | | | | | | | | |
| | | | | | | | 3 | 4 | 5 | 6 | 7 | 8 | 9 | 10 | 11 | 12 | 13 | 14 | 15 | | |
| PA2 | PA1 | PA0 | OBE | IBE | DSC1 | DSC0 | ODE | HYS | SRC1 | SRC0 | WPE | WPS | | | | | | | | | |
| 97 | 0x0102 | GPIO97 | PCSA1 | — | — | — | — | — | 0 | 0 | 0 | — | — | 0 | 0 | 0 | 0 | 1 | 1 | | |
| 98 | 0x0104 | GPIO98 | PCSA2 | — | — | — | — | — | 0 | 0 | 0 | — | — | 0 | 0 | 0 | 0 | 1 | 1 | | |
| 99 | 0x0106 | GPIO99 | PCSA3 | — | — | — | — | — | 0 | 0 | 0 | — | — | 0 | 0 | 0 | 0 | 1 | 1 | | |
| 100 | 0x0108 | GPIO100 | PCSA4 | — | — | — | — | — | 0 | 0 | 0 | — | — | 0 | 0 | 0 | 0 | 1 | 1 | | |
| 101 | 0x010A | GPIO101 | PCSA5 | ETRIG1 | — | — | — | — | 0 | 0 | 0 | — | — | 0 | 0 | 0 | 0 | 1 | 1 | | |
| 102 | 0x010C | GPIO102 | SCKB | — | — | — | — | — | 0 | 0 | 0 | — | — | 0 | 0 | 0 | 0 | 1 | 1 | | |
| 103 | 0x010E | GPIO103 | SINB | — | — | — | — | — | 0 | 0 | 0 | — | — | 0 | 0 | 0 | 0 | 1 | 1 | | |
| 104 | 0x0110 | GPIO104 | SOUTB | — | — | — | — | — | 0 | 0 | 0 | — | — | 0 | 0 | 0 | 0 | 1 | 1 | | |
| 105 | 0x0112 | GPIO105 | PCSB0 | PCSD2 | — | — | — | — | 0 | 0 | 0 | — | — | 0 | 0 | 0 | 0 | 1 | 1 | | |
| 106 | 0x0114 | GPIO106 | PCSB1 | PCSD0 | — | — | — | — | 0 | 0 | 0 | — | — | 0 | 0 | 0 | 0 | 1 | 1 | | |
| 107 | 0x0116 | GPIO107 | PCSB2 | SOUTC | — | — | — | — | 0 | 0 | 0 | — | — | 0 | 0 | 0 | 0 | 1 | 1 | | |
| 108 | 0x0118 | GPIO108 | PCSB3 | SINC ⁴ | — | — | — | — | 0 | 0 | 0 | — | — | 0 | 0 | 0 | 0 | 1 | 1 | | |
| 109 | 0x011A | GPIO109 | PCSB4 | SCKC ⁴ | — | — | — | — | 0 | 0 | 0 | — | — | 0 | 0 | 0 | 0 | 1 | 1 | | |
| 110 | 0x011C | GPIO110 | PCSB5 | PCSC0 ⁴ | — | — | — | — | 0 | 0 | 0 | — | — | 0 | 0 | 0 | 0 | 1 | 1 | | |
| 113 | 0x0122 | GPIO113 | TCRCLKA | IRQ7 | — | — | — | — | 0 | 0 | 0 | — | — | 0 | 0 | 0 | 0 | 1 | 1 | | |
| 114 | 0x0124 | GPIO114 | ETPUA0 | ETPUA12 | — | — | — | — | 0 | 0 | 0 | — | — | 0 | 0 | 0 | 0 | 1 | U | | |
| 115 | 0x0126 | GPIO115 | ETPUA1 | ETPUA13 | — | — | — | — | 0 | 0 | 0 | — | — | 0 | 0 | 0 | 0 | 1 | U | | |
| 116 | 0x0128 | GPIO116 | ETPUA2 | ETPUA14 | — | — | — | — | 0 | 0 | 0 | — | — | 0 | 0 | 0 | 0 | 1 | U | | |
| 117 | 0x012A | GPIO117 | ETPUA3 | ETPUA15 | — | — | — | — | 0 | 0 | 0 | — | — | 0 | 0 | 0 | 0 | 1 | U | | |
| 118 | 0x012C | GPIO118 | ETPUA4 | ETPUA16 | — | — | — | — | 0 | 0 | 0 | — | — | 0 | 0 | 0 | 0 | 1 | U | | |
| 119 | 0x012E | GPIO119 | ETPUA5 | ETPUA17 | — | — | — | — | 0 | 0 | 0 | — | — | 0 | 0 | 0 | 0 | 1 | U | | |
| 120 | 0x0130 | GPIO120 | ETPUA6 | ETPUA18 | — | — | — | — | 0 | 0 | 0 | — | — | 0 | 0 | 0 | 0 | 1 | U | | |
| 121 | 0x0132 | GPIO121 | ETPUA7 | ETPUA19 | — | — | — | — | 0 | 0 | 0 | — | — | 0 | 0 | 0 | 0 | 1 | U | | |

Table 7-22. SIU_PCRn Settings (continued)

| PCRn | Address Offset | GPIO | Primary Function | A2 | A3 | A4 | SIU_PCRn[3:15] ¹ (SIU_PCRn[0:2] = Reserved, should be cleared) | | | | | | | | | | | | | | |
|------|----------------|---------|----------------------|---------|----|----|--|-----|-----|-----|-----|------|------|-----|-----|------|------|-----|-----|--|--|
| | | | | | | | 3 | 4 | 5 | 6 | 7 | 8 | 9 | 10 | 11 | 12 | 13 | 14 | 15 | | |
| | | | | | | | PA2 | PA1 | PA0 | OBE | IBE | DSC1 | DSC0 | ODE | HYS | SRC1 | SRC0 | WPE | WPS | | |
| 122 | 0x0134 | GPIO122 | ETPUA8 | ETPUA20 | — | — | — | 0 | 0 | 0 | 0 | — | — | 0 | 0 | 0 | 0 | 1 | U | | |
| 123 | 0x0136 | GPIO123 | ETPUA9 | ETPUA21 | — | — | — | 0 | 0 | 0 | 0 | — | — | 0 | 0 | 0 | 0 | 1 | U | | |
| 124 | 0x0138 | GPIO124 | ETPUA10 | ETPUA22 | — | — | — | 0 | 0 | 0 | 0 | — | — | 0 | 0 | 0 | 0 | 1 | U | | |
| 125 | 0x013A | GPIO125 | ETPUA11 | ETPUA23 | — | — | — | 0 | 0 | 0 | 0 | — | — | 0 | 0 | 0 | 0 | 1 | U | | |
| 126 | 0x013C | GPIO126 | ETPUA12 | PCSB1 | — | — | — | 0 | 0 | 0 | 0 | — | — | 0 | 0 | 0 | 0 | 1 | U | | |
| 127 | 0x013E | GPIO127 | ETPUA13 | PCSB3 | — | — | — | 0 | 0 | 0 | 0 | — | — | 0 | 0 | 0 | 0 | 1 | U | | |
| 128 | 0x0140 | GPIO128 | ETPUA14 | PCSB4 | — | — | — | 0 | 0 | 0 | 0 | — | — | 0 | 0 | 0 | 0 | 1 | U | | |
| 129 | 0x0142 | GPIO129 | ETPUA15 | PCSB5 | — | — | — | 0 | 0 | 0 | 0 | — | — | 0 | 0 | 0 | 0 | 1 | U | | |
| 130 | 0x0144 | GPIO130 | ETPUA16 | PCSD1 | — | — | — | 0 | 0 | 0 | 0 | — | — | 0 | 0 | 0 | 0 | 1 | U | | |
| 131 | 0x0146 | GPIO131 | ETPUA17 | PCSD2 | — | — | — | 0 | 0 | 0 | 0 | — | — | 0 | 0 | 0 | 0 | 1 | U | | |
| 132 | 0x0148 | GPIO132 | ETPUA18 | PCSD3 | — | — | — | 0 | 0 | 0 | 0 | — | — | 0 | 0 | 0 | 0 | 1 | U | | |
| 133 | 0x014A | GPIO133 | ETPUA19 | PCSD4 | — | — | — | 0 | 0 | 0 | 0 | — | — | 0 | 0 | 0 | 0 | 1 | U | | |
| 134 | 0x014C | GPIO134 | ETPUA20 | IRQ8 | — | — | — | 0 | 0 | 0 | 0 | — | — | 0 | 0 | 0 | 0 | 1 | U | | |
| 135 | 0x014E | GPIO135 | ETPUA21 | IRQ9 | — | — | — | 0 | 0 | 0 | 0 | — | — | 0 | 0 | 0 | 0 | 1 | U | | |
| 136 | 0x0150 | GPIO136 | ETPUA22 | IRQ10 | — | — | — | 0 | 0 | 0 | 0 | — | — | 0 | 0 | 0 | 0 | 1 | U | | |
| 137 | 0x0152 | GPIO137 | ETPUA23 | IRQ11 | — | — | — | 0 | 0 | 0 | 0 | — | — | 0 | 0 | 0 | 0 | 1 | U | | |
| 138 | 0x0154 | GPIO138 | ETPUA24 ⁵ | IRQ12 | — | — | — | 0 | 0 | 0 | 0 | — | — | 0 | 0 | 0 | 0 | 1 | U | | |
| 139 | 0x0156 | GPIO139 | ETPUA25 ⁵ | IRQ13 | — | — | — | 0 | 0 | 0 | 0 | — | — | 0 | 0 | 0 | 0 | 1 | U | | |
| 140 | 0x0158 | GPIO140 | ETPUA26 ⁵ | IRQ14 | — | — | — | 0 | 0 | 0 | 0 | — | — | 0 | 0 | 0 | 0 | 1 | U | | |
| 141 | 0x015A | GPIO141 | ETPUA27 ⁵ | IRQ15 | — | — | — | 0 | 0 | 0 | 0 | — | — | 0 | 0 | 0 | 0 | 1 | U | | |
| 142 | 0x015C | GPIO142 | ETPUA28 ⁵ | PCSC1 | — | — | — | 0 | 0 | 0 | 0 | — | — | 0 | 0 | 0 | 0 | 1 | U | | |
| 143 | 0x015E | GPIO143 | ETPUA29 ⁵ | PCSC2 | — | — | — | 0 | 0 | 0 | 0 | — | — | 0 | 0 | 0 | 0 | 1 | U | | |
| 144 | 0x0160 | GPIO144 | ETPUA30 | PCSC3 | — | — | — | 0 | 0 | 0 | 0 | — | — | 0 | 0 | 0 | 0 | 1 | U | | |

Table 7-22. SIU_PCRn Settings (continued)

| PCRn | Address Offset | GPIO | Primary Function | A2 | A3 | A4 | SIU_PCRn[3:15] ¹ (SIU_PCRn[0:2] = Reserved, should be cleared) | | | | | | | | | | | | | | |
|------|----------------|---------|------------------|---------|----|----|--|-----|-----|-----|-----|------|------|-----|-----|------|------|-----|-----|--|--|
| | | | | | | | 3 | 4 | 5 | 6 | 7 | 8 | 9 | 10 | 11 | 12 | 13 | 14 | 15 | | |
| | | | | | | | PA2 | PA1 | PA0 | OBE | IBE | DSC1 | DSC0 | ODE | HYS | SRC1 | SRC0 | WPE | WPS | | |
| 145 | 0x0162 | GPIO145 | ETPUA31 | PCSC4 | — | — | — | 0 | 0 | 0 | 0 | — | — | 0 | 0 | 0 | 0 | 1 | U | | |
| 146 | 0x0164 | GPIO146 | TCRCLKB | IRQ6 | — | — | — | 0 | 0 | 0 | 0 | — | — | 0 | 0 | 0 | 0 | 1 | 1 | | |
| 147 | 0x0166 | GPIO147 | ETPUB0 | ETPUB16 | — | — | — | 0 | 0 | 0 | 0 | — | — | 0 | 0 | 0 | 0 | 1 | U | | |
| 148 | 0x0168 | GPIO148 | ETPUB1 | ETPUB17 | — | — | — | 0 | 0 | 0 | 0 | — | — | 0 | 0 | 0 | 0 | 1 | U | | |
| 149 | 0x016A | GPIO149 | ETPUB2 | ETPUB18 | — | — | — | 0 | 0 | 0 | 0 | — | — | 0 | 0 | 0 | 0 | 1 | U | | |
| 150 | 0x016C | GPIO150 | ETPUB3 | ETPUB19 | — | — | — | 0 | 0 | 0 | 0 | — | — | 0 | 0 | 0 | 0 | 1 | U | | |
| 151 | 0x016E | GPIO151 | ETPUB4 | ETPUB20 | — | — | — | 0 | 0 | 0 | 0 | — | — | 0 | 0 | 0 | 0 | 1 | U | | |
| 152 | 0x0170 | GPIO152 | ETPUB5 | ETPUB21 | — | — | — | 0 | 0 | 0 | 0 | — | — | 0 | 0 | 0 | 0 | 1 | U | | |
| 153 | 0x0172 | GPIO153 | ETPUB6 | ETPUB22 | — | — | — | 0 | 0 | 0 | 0 | — | — | 0 | 0 | 0 | 0 | 1 | U | | |
| 154 | 0x0174 | GPIO154 | ETPUB7 | ETPUB23 | — | — | — | 0 | 0 | 0 | 0 | — | — | 0 | 0 | 0 | 0 | 1 | U | | |
| 155 | 0x0176 | GPIO155 | ETPUB8 | ETPUB24 | — | — | — | 0 | 0 | 0 | 0 | — | — | 0 | 0 | 0 | 0 | 1 | U | | |
| 156 | 0x0178 | GPIO156 | ETPUB9 | ETPUB25 | — | — | — | 0 | 0 | 0 | 0 | — | — | 0 | 0 | 0 | 0 | 1 | U | | |
| 157 | 0x017A | GPIO157 | ETPUB10 | ETPUB26 | — | — | — | 0 | 0 | 0 | 0 | — | — | 0 | 0 | 0 | 0 | 1 | U | | |
| 158 | 0x017C | GPIO158 | ETPUB11 | ETPUB27 | — | — | — | 0 | 0 | 0 | 0 | — | — | 0 | 0 | 0 | 0 | 1 | U | | |
| 159 | 0x017E | GPIO159 | ETPUB12 | ETPUB28 | — | — | — | 0 | 0 | 0 | 0 | — | — | 0 | 0 | 0 | 0 | 1 | U | | |
| 160 | 0x0180 | GPIO160 | ETPUB13 | ETPUB29 | — | — | — | 0 | 0 | 0 | 0 | — | — | 0 | 0 | 0 | 0 | 1 | U | | |
| 161 | 0x0182 | GPIO161 | ETPUB14 | ETPUB30 | — | — | — | 0 | 0 | 0 | 0 | — | — | 0 | 0 | 0 | 0 | 1 | U | | |
| 162 | 0x0184 | GPIO162 | ETPUB15 | ETPUB31 | — | — | — | 0 | 0 | 0 | 0 | — | — | 0 | 0 | 0 | 0 | 1 | U | | |
| 163 | 0x0186 | GPIO163 | ETPUB16 | PCSA1 | — | — | — | 0 | 0 | 0 | 0 | — | — | 0 | 0 | 0 | 0 | 1 | U | | |
| 164 | 0x0188 | GPIO164 | ETPUB17 | PCSA2 | — | — | — | 0 | 0 | 0 | 0 | — | — | 0 | 0 | 0 | 0 | 1 | U | | |
| 165 | 0x018A | GPIO165 | ETPUB18 | PCSA3 | — | — | — | 0 | 0 | 0 | 0 | — | — | 0 | 0 | 0 | 0 | 1 | U | | |
| 166 | 0x018C | GPIO166 | ETPUB19 | PCSA4 | — | — | — | 0 | 0 | 0 | 0 | — | — | 0 | 0 | 0 | 0 | 1 | U | | |
| 167 | 0x018E | GPIO167 | ETPUB20 | — | — | — | — | — | 0 | 0 | 0 | — | — | 0 | 0 | 0 | 0 | 1 | U | | |

Table 7-22. SIU_PCRn Settings (continued)

| PCRn | Address Offset | GPIO | Primary Function | A2 | A3 | A4 | SIU_PCRn[3:15] ¹ | | | | | | | | | | | | | | |
|------|----------------|---------|------------------|--------|------|------|---|-----|------|------|-----|-----|---|----|----|----|----|----|----|--|--|
| | | | | | | | (SIU_PCRn[0:2] = Reserved, should be cleared) | | | | | | | | | | | | | | |
| | | | | | | | 3 | 4 | 5 | 6 | 7 | 8 | 9 | 10 | 11 | 12 | 13 | 14 | 15 | | |
| PA2 | PA1 | PA0 | OBE | IBE | DSC1 | DSC0 | ODE | HYS | SRC1 | SRC0 | WPE | WPS | | | | | | | | | |
| 168 | 0x0190 | GPIO168 | ETPUB21 | — | — | — | — | — | 0 | 0 | 0 | — | — | 0 | 0 | 0 | 0 | 1 | U | | |
| 169 | 0x0192 | GPIO169 | ETPUB22 | — | — | — | — | — | 0 | 0 | 0 | — | — | 0 | 0 | 0 | 0 | 1 | U | | |
| 170 | 0x0194 | GPIO170 | ETPUB23 | — | — | — | — | — | 0 | 0 | 0 | — | — | 0 | 0 | 0 | 0 | 1 | U | | |
| 171 | 0x0196 | GPIO171 | ETPUB24 | — | — | — | — | — | 0 | 0 | 0 | — | — | 0 | 0 | 0 | 0 | 1 | U | | |
| 172 | 0x0198 | GPIO172 | ETPUB25 | — | — | — | — | — | 0 | 0 | 0 | — | — | 0 | 0 | 0 | 0 | 1 | U | | |
| 173 | 0x019A | GPIO173 | ETPUB26 | — | — | — | — | — | 0 | 0 | 0 | — | — | 0 | 0 | 0 | 0 | 1 | U | | |
| 174 | 0x019C | GPIO174 | ETPUB27 | — | — | — | — | — | 0 | 0 | 0 | — | — | 0 | 0 | 0 | 0 | 1 | U | | |
| 175 | 0x019E | GPIO175 | ETPUB28 | — | — | — | — | — | 0 | 0 | 0 | — | — | 0 | 0 | 0 | 0 | 1 | U | | |
| 176 | 0x01A0 | GPIO176 | ETPUB29 | — | — | — | — | — | 0 | 0 | 0 | — | — | 0 | 0 | 0 | 0 | 1 | U | | |
| 177 | 0x01A2 | GPIO177 | ETPUB30 | — | — | — | — | — | 0 | 0 | 0 | — | — | 0 | 0 | 0 | 0 | 1 | U | | |
| 178 | 0x01A4 | GPIO178 | ETPUB31 | — | — | — | — | — | 0 | 0 | 0 | — | — | 0 | 0 | 0 | 0 | 1 | U | | |
| 179 | 0x01A6 | GPIO179 | EMIOS0 | ETPUA0 | — | — | — | — | 0 | 0 | 0 | 0 | — | — | 0 | 0 | 0 | 1 | U | | |
| 180 | 0x01A8 | GPIO180 | EMIOS1 | ETPUA1 | — | — | — | — | 0 | 0 | 0 | 0 | — | — | 0 | 0 | 0 | 1 | U | | |
| 181 | 0x01AA | GPIO181 | EMIOS2 | ETPUA2 | — | — | — | — | 0 | 0 | 0 | 0 | — | — | 0 | 0 | 0 | 1 | U | | |
| 182 | 0x01AC | GPIO182 | EMIOS3 | ETPUA3 | — | — | — | — | 0 | 0 | 0 | 0 | — | — | 0 | 0 | 0 | 1 | U | | |
| 183 | 0x01AE | GPIO183 | EMIOS4 | ETPUA4 | — | — | — | — | 0 | 0 | 0 | 0 | — | — | 0 | 0 | 0 | 1 | U | | |
| 184 | 0x01B0 | GPIO184 | EMIOS5 | ETPUA5 | — | — | — | — | 0 | 0 | 0 | 0 | — | — | 0 | 0 | 0 | 1 | U | | |
| 185 | 0x01B2 | GPIO185 | EMIOS6 | ETPUA6 | — | — | — | — | 0 | 0 | 0 | 0 | — | — | 0 | 0 | 0 | 1 | U | | |
| 186 | 0x01B4 | GPIO186 | EMIOS7 | ETPUA7 | — | — | — | — | 0 | 0 | 0 | 0 | — | — | 0 | 0 | 0 | 1 | U | | |
| 187 | 0x01B6 | GPIO187 | EMIOS8 | ETPUA8 | — | — | — | — | 0 | 0 | 0 | 0 | — | — | 0 | 0 | 0 | 1 | U | | |
| 188 | 0x01B8 | GPIO188 | EMIOS9 | ETPUA9 | — | — | — | — | 0 | 0 | 0 | 0 | — | — | 0 | 0 | 0 | 1 | U | | |
| 189 | 0x01BA | GPIO189 | EMIOS10 | SCKD | — | — | — | — | 0 | 0 | 0 | 0 | — | — | 0 | 0 | 0 | 1 | U | | |
| 190 | 0x01BC | GPIO190 | EMIOS11 | SIND | — | — | — | — | 0 | 0 | 0 | 0 | — | — | 0 | 0 | 0 | 1 | U | | |

Table 7-22. SIU_PCRn Settings (continued)

| PCRn | Address Offset | GPIO | Primary Function | A2 | A3 | A4 | SIU_PCRn[3:15] ¹ | | | | | | | | | | | | | | |
|------|----------------|----------------------|------------------|--------------------|--------------------|------|---|-----|------|------|-----|-----|---|----|----|----|----|----|----|--|--|
| | | | | | | | (SIU_PCRn[0:2] = Reserved, should be cleared) | | | | | | | | | | | | | | |
| | | | | | | | 3 | 4 | 5 | 6 | 7 | 8 | 9 | 10 | 11 | 12 | 13 | 14 | 15 | | |
| PA2 | PA1 | PA0 | OBE | IBE | DSC1 | DSC0 | ODE | HYS | SRC1 | SRC0 | WPE | WPS | | | | | | | | | |
| 191 | 0x01BE | GPIO191 | EMIOS12 | SOUTC | — | — | — | 0 | 0 | 0 | 0 | — | — | 0 | 0 | 0 | 0 | 1 | U | | |
| 192 | 0x01C0 | GPIO192 | EMIOS13 | SOUTD | — | — | — | 0 | 0 | 0 | 0 | — | — | 0 | 0 | 0 | 0 | 1 | U | | |
| 193 | 0x01C2 | GPIO193 | EMIOS14 | IRQ0 | CNTXD | — | — | 0 | 0 | 0 | 0 | — | — | 0 | 0 | 0 | 0 | 1 | U | | |
| 194 | 0x01C4 | GPIO194 | EMIOS15 | IRQ1 | CNRXD ⁴ | — | — | 0 | 0 | 0 | 0 | — | — | 0 | 0 | 0 | 0 | 1 | U | | |
| 195 | 0x01C6 | GPIO195 | EMIOS16 | ETPUB0 | FR_DBG[3] | — | — | 0 | 0 | 0 | 0 | — | — | 0 | 0 | 0 | 0 | 1 | U | | |
| 196 | 0x01C8 | GPIO196 | EMIOS17 | ETPUB1 | FR_DBG[2] | — | — | 0 | 0 | 0 | 0 | — | — | 0 | 0 | 0 | 0 | 1 | U | | |
| 197 | 0x01CA | GPIO197 | EMIOS18 | ETPUB2 | FR_DBG[1] | — | — | 0 | 0 | 0 | 0 | — | — | 0 | 0 | 0 | 0 | 1 | U | | |
| 198 | 0x01CC | GPIO198 | EMIOS19 | ETPUB3 | FR_DBG[0] | — | — | 0 | 0 | 0 | 0 | — | — | 0 | 0 | 0 | 0 | 1 | U | | |
| 199 | 0x01CE | GPIO199 | EMIOS20 | ETPUB4 | — | — | — | 0 | 0 | 0 | 0 | — | — | 0 | 0 | 0 | 0 | 1 | U | | |
| 200 | 0x01D0 | GPIO200 | EMIOS21 | ETPUB5 | — | — | — | 0 | 0 | 0 | 0 | — | — | 0 | 0 | 0 | 0 | 1 | U | | |
| 201 | 0x01D2 | GPIO201 | EMIOS22 | ETPUB6 | — | — | — | 0 | 0 | 0 | 0 | — | — | 0 | 0 | 0 | 0 | 1 | U | | |
| 202 | 0x01D4 | GPIO202 | EMIOS23 | ETPUB7 | — | — | — | 0 | 0 | 0 | 0 | — | — | 0 | 0 | 0 | 0 | 1 | U | | |
| 203 | 0x01D6 | GPIO203 | EMIOS24 | PCSB0 ⁴ | — | — | — | 0 | 0 | 0 | 0 | — | — | 0 | 0 | 0 | 0 | 1 | U | | |
| 204 | 0x01D8 | GPIO204 | EMIOS25 | PCSB1 | — | — | — | 0 | 0 | 0 | 0 | — | — | 0 | 0 | 0 | 0 | 1 | U | | |
| 208 | 0x01E0 | GPIO208 | PLLCFG0 | IRQ4 | — | — | — | 0 | 1 | 0 | 0 | — | — | 0 | 1 | 0 | 0 | 1 | 1 | | |
| 209 | 0x01E2 | GPIO209 | PLLCFG1 | IRQ5 | SOUTD | — | — | 0 | 1 | 0 | 0 | — | — | 0 | 1 | 0 | 0 | 1 | 1 | | |
| 211 | 0x01E6 | GPIO211 | BOOTCFG0 | IRQ2 | — | — | — | 0 | 1 | 0 | 0 | — | — | 0 | 1 | 0 | 0 | 1 | 0 | | |
| 212 | 0x01E8 | GPIO212 | BOOTCFG1 | IRQ3 | — | — | — | 0 | 1 | 0 | 0 | — | — | 0 | 1 | 0 | 0 | 1 | 0 | | |
| 213 | 0x01EA | GPIO213 | WKPCFG | NMI | — | — | — | — | 1 | 0 | 0 | — | — | — | 1 | 0 | 0 | 1 | 1 | | |
| 214 | 0x01EC | — | ENGCLK | — | — | — | — | — | — | 1 | — | 1 | 1 | — | — | — | — | — | — | | |
| 219 | 0x01F6 | — | MCKO | — | — | — | — | — | — | — | — | 1 | 1 | — | — | — | — | — | — | | |
| 220 | 0x01F8 | GPIO220 ³ | MDO0 | — | — | — | — | — | — | 0 | 0 | 1 | 1 | 0 | 0 | 0 | 0 | — | — | | |
| 221 | 0x01FA | GPIO221 ³ | MDO1 | — | — | — | — | — | — | 0 | 0 | 1 | 1 | 0 | 0 | 0 | 0 | 0 | 0 | | |

Table 7-22. SIU_PCRn Settings (continued)

| PCRn | Address Offset | GPIO | Primary Function | A2 | A3 | A4 | SIU_PCRn[3:15] ¹ | | | | | | | | | | | | | | |
|------------------|----------------|----------------------|------------------|--------------|------|------|---|-----|------|------|-----|-----|---|----|----|----|----|----|----|---|--|
| | | | | | | | (SIU_PCRn[0:2] = Reserved, should be cleared) | | | | | | | | | | | | | | |
| | | | | | | | 3 | 4 | 5 | 6 | 7 | 8 | 9 | 10 | 11 | 12 | 13 | 14 | 15 | | |
| PA2 | PA1 | PA0 | OBE | IBE | DSC1 | DSC0 | ODE | HYS | SRC1 | SRC0 | WPE | WPS | | | | | | | | | |
| 222 | 0x01FC | GPIO222 ³ | MDO2 | — | — | — | — | — | 0 | 0 | 1 | 1 | 0 | 0 | 0 | 0 | 0 | 0 | | | |
| 223 | 0x01FE | GPIO223 ³ | MDO3 | — | — | — | — | — | 0 | 0 | 1 | 1 | 0 | 0 | 0 | 0 | 0 | 0 | | | |
| 224 | 0x0200 | — | MSEO0 | — | — | — | — | — | — | — | 1 | 1 | — | — | — | — | — | — | | | |
| 225 | 0x0202 | — | MSEO1 | — | — | — | — | — | — | — | 1 | 1 | — | — | — | — | — | — | | | |
| 226 | 0x0204 | — | RDY | — | — | — | — | — | — | — | 1 | 1 | — | — | — | — | — | — | | | |
| 227 | 0x0206 | — | EVTO | — | — | — | — | — | — | — | 1 | 1 | — | — | — | — | — | — | | | |
| 228 | 0x0208 | — | TDO | — | — | — | — | — | — | — | 1 | 1 | — | — | — | — | — | — | | | |
| 229 | 0x020A | — | D_CLKOUT | — | — | — | — | — | 1 | — | 1 | 1 | — | — | — | — | — | — | | | |
| 230 | 0x020C | — | RSTOUT | — | — | — | — | — | — | — | — | — | — | — | 1 | 1 | — | — | | | |
| 231 ⁶ | 0x020E | GPIO231 | MDO12 | — | — | — | — | — | 0 | 0 | 1 | 1 | 0 | 0 | — | — | 0 | 0 | | | |
| 232 ⁶ | 0x0210 | GPIO232 | MDO13 | — | — | — | — | — | 0 | 0 | 1 | 1 | 0 | 0 | — | — | 0 | 0 | | | |
| 233 ⁶ | 0x0212 | GPIO233 | MDO14 | — | — | — | — | — | 0 | 0 | 1 | 1 | 0 | 0 | — | — | 0 | 0 | | | |
| 234 ⁶ | 0x0214 | GPIO234 | MDO15 | — | — | — | — | — | 0 | 0 | 1 | 1 | 0 | 0 | — | — | 0 | 0 | | | |
| 235 | 0x0216 | GPIO235 | SCKC | SCK_C_LVDS+ | — | — | — | — | 0 | 0 | 0 | 0 | — | — | 0 | 0 | 0 | 0 | 1 | 1 | |
| 236 | 0x0218 | GPIO236 | SINC | SCK_C_LVDS- | — | — | — | — | 0 | 0 | 0 | 0 | — | — | 0 | 0 | 0 | 0 | 1 | 1 | |
| 237 | 0x021A | GPIO237 | SOUTC | SOUT_C_LVDS+ | — | — | — | — | 0 | 0 | 0 | 0 | — | — | 0 | 0 | 0 | 0 | 1 | 1 | |
| 238 | 0x021C | GPIO238 | PCSC0 | SOUT_C_LVDS- | — | — | — | — | 0 | 0 | 0 | 0 | — | — | 0 | 0 | 0 | 0 | 1 | 1 | |
| 239 | 0x021E | GPIO239 | PCSC1 | — | — | — | — | — | 0 | 0 | 0 | 0 | — | — | 0 | 0 | 0 | 0 | 1 | 1 | |
| 240 | 0x0220 | GPIO240 | PCSC2 | — | — | — | — | — | 0 | 0 | 0 | 0 | — | — | 0 | 0 | 0 | 0 | 1 | 1 | |
| 241 | 0x0222 | GPIO241 | PCSC3 | — | — | — | — | — | 0 | 0 | 0 | 0 | — | — | 0 | 0 | 0 | 0 | 1 | 1 | |
| 242 | 0x0224 | GPIO242 | PCSC4 | — | — | — | — | — | 0 | 0 | 0 | 0 | — | — | 0 | 0 | 0 | 0 | 1 | 1 | |
| 243 | 0x0226 | GPIO243 | PCSC5 | — | — | — | — | — | 0 | 0 | 0 | 0 | — | — | 0 | 0 | 0 | 0 | 1 | 1 | |
| 244 | 0x0228 | GPIO244 | TXDC | ETRIG0 | — | — | — | — | 0 | 0 | 0 | 0 | — | — | 0 | 0 | 0 | 0 | 1 | 1 | |

Table 7-22. SIU_PCRn Settings (continued)

| PCRn | Address Offset | GPIO | Primary Function | A2 | A3 | A4 | SIU_PCRn[3:15] ¹ | | | | | | | | | | | | | | |
|------|----------------|---------|------------------|-------------|------|------|---|-----|------|------|-----|-----|---|----|----|----|----|----------------|------------------|---|--|
| | | | | | | | (SIU_PCRn[0:2] = Reserved, should be cleared) | | | | | | | | | | | | | | |
| | | | | | | | 3 | 4 | 5 | 6 | 7 | 8 | 9 | 10 | 11 | 12 | 13 | 14 | 15 | | |
| PA2 | PA1 | PA0 | OBE | IBE | DSC1 | DSC0 | ODE | HYS | SRC1 | SRC0 | WPE | WPS | | | | | | | | | |
| 245 | 0x022A | GPIO245 | RXDC | — | — | — | — | — | 0 | 0 | 0 | — | — | 0 | 0 | 0 | 0 | 1 | 1 | | |
| 246 | 0x022C | GPIO246 | CNTXD | — | — | — | — | — | 0 | 0 | 0 | — | — | 0 | 0 | 0 | 0 | 1 | 1 | | |
| 247 | 0x022E | GPIO247 | CNRXD | — | — | — | — | — | 0 | 0 | 0 | — | — | 0 | 0 | 0 | 0 | 1 | 1 | | |
| 248 | 0x0230 | GPIO248 | FR_A_TX | — | — | — | — | — | 0 | 0 | 0 | — | — | 0 | 0 | 0 | 0 | 1 ⁷ | 1 ⁷ | | |
| 249 | 0x0232 | GPIO249 | FR_A_RX | — | — | — | — | — | 0 | 0 | 0 | — | — | 0 | 0 | 0 | 0 | 1 ⁷ | 1 ⁷ 0 | | |
| 250 | 0x0234 | GPIO250 | FR_A_TX_EN | — | — | — | — | — | 0 | 0 | 0 | — | — | 0 | 0 | 0 | 0 | 1 ⁷ | 1 ⁷ 0 | | |
| 251 | 0x0236 | GPIO251 | FR_B_TX | — | — | — | — | — | 0 | 0 | 0 | — | — | 0 | 0 | 0 | 0 | 1 ⁷ | 1 ⁷ 0 | | |
| 252 | 0x0238 | GPIO252 | FR_B_RX | — | — | — | — | — | 0 | 0 | 0 | — | — | 0 | 0 | 0 | 0 | 1 ⁷ | 1 ⁷ 0 | | |
| 253 | 0x023A | GPIO253 | FR_B_TX_EN | — | — | — | — | — | 0 | 0 | 0 | — | — | 0 | 0 | 0 | 0 | 1 ⁷ | 1 ⁷ | | |
| 256 | 0x0240 | GPIO256 | D_CS0 | — | — | — | — | — | 0 | 0 | 0 | 0 | 0 | 0 | 0 | 0 | — | — | 1 | 1 | |
| 257 | 0x0242 | GPIO257 | D_CS2 | D_ADD_DAT31 | — | — | — | — | 0 | 0 | 0 | 0 | 0 | 0 | 0 | 0 | — | — | 1 | 1 | |
| 258 | 0x0244 | GPIO258 | D_CS3 | D_TEA | — | — | — | — | 0 | 0 | 0 | 0 | 0 | 0 | 0 | 0 | — | — | 1 | 1 | |
| 259 | 0x0246 | GPIO259 | D_ADD12 | — | — | — | — | — | 0 | 0 | 0 | 0 | 0 | 0 | 0 | 0 | — | — | 1 | 1 | |
| 260 | 0x0248 | GPIO260 | D_ADD13 | — | — | — | — | — | 0 | 0 | 0 | 0 | 0 | 0 | 0 | 0 | — | — | 1 | 1 | |
| 261 | 0x024A | GPIO261 | D_ADD14 | — | — | — | — | — | 0 | 0 | 0 | 0 | 0 | 0 | 0 | 0 | — | — | 1 | 1 | |
| 262 | 0x024C | GPIO262 | D_ADD15 | — | — | — | — | — | 0 | 0 | 0 | 0 | 0 | 0 | 0 | 0 | — | — | 1 | 1 | |
| 263 | 0x024E | GPIO263 | D_ADD16 | D_ADD_DAT16 | — | — | — | — | 0 | 0 | 0 | 0 | 0 | 0 | 0 | 0 | — | — | 1 | 1 | |
| 264 | 0x0250 | GPIO264 | D_ADD17 | D_ADD_DAT17 | — | — | — | — | 0 | 0 | 0 | 0 | 0 | 0 | 0 | 0 | — | — | 1 | 1 | |
| 265 | 0x0252 | GPIO265 | D_ADD18 | D_ADD_DAT18 | — | — | — | — | 0 | 0 | 0 | 0 | 0 | 0 | 0 | 0 | — | — | 1 | 1 | |
| 266 | 0x0254 | GPIO266 | D_ADD19 | D_ADD_DAT19 | — | — | — | — | 0 | 0 | 0 | 0 | 0 | 0 | 0 | 0 | — | — | 1 | 1 | |
| 267 | 0x0256 | GPIO267 | D_ADD20 | D_ADD_DAT20 | — | — | — | — | 0 | 0 | 0 | 0 | 0 | 0 | 0 | 0 | — | — | 1 | 1 | |
| 268 | 0x0258 | GPIO268 | D_ADD21 | D_ADD_DAT21 | — | — | — | — | 0 | 0 | 0 | 0 | 0 | 0 | 0 | 0 | — | — | 1 | 1 | |
| 269 | 0x025A | GPIO269 | D_ADD22 | D_ADD_DAT22 | — | — | — | — | 0 | 0 | 0 | 0 | 0 | 0 | 0 | 0 | — | — | 1 | 1 | |

Table 7-22. SIU_PCRn Settings (continued)

| PCRn | Address Offset | GPIO | Primary Function | A2 | A3 | A4 | SIU_PCRn[3:15] ¹ (SIU_PCRn[0:2] = Reserved, should be cleared) | | | | | | | | | | | | | | |
|------|----------------|---------|------------------|-------------|----|----|--|-----|-----|-----|-----|------|------|-----|-----|------|------|-----|-----|--|--|
| | | | | | | | 3 | 4 | 5 | 6 | 7 | 8 | 9 | 10 | 11 | 12 | 13 | 14 | 15 | | |
| | | | | | | | PA2 | PA1 | PA0 | OBE | IBE | DSC1 | DSC0 | ODE | HYS | SRC1 | SRC0 | WPE | WPS | | |
| 270 | 0x025C | GPIO270 | D_ADD23 | D_ADD_DAT23 | — | — | — | 0 | 0 | 0 | 0 | 0 | 0 | 0 | 0 | — | — | 1 | 1 | | |
| 271 | 0x025E | GPIO271 | D_ADD24 | D_ADD_DAT24 | — | — | — | 0 | 0 | 0 | 0 | 0 | 0 | 0 | 0 | — | — | 1 | 1 | | |
| 272 | 0x0260 | GPIO272 | D_ADD25 | D_ADD_DAT25 | — | — | — | 0 | 0 | 0 | 0 | 0 | 0 | 0 | 0 | — | — | 1 | 1 | | |
| 273 | 0x0262 | GPIO273 | D_ADD26 | D_ADD_DAT26 | — | — | — | 0 | 0 | 0 | 0 | 0 | 0 | 0 | 0 | — | — | 1 | 1 | | |
| 274 | 0x0264 | GPIO274 | D_ADD27 | D_ADD_DAT27 | — | — | — | 0 | 0 | 0 | 0 | 0 | 0 | 0 | 0 | — | — | 1 | 1 | | |
| 275 | 0x0266 | GPIO275 | D_ADD28 | D_ADD_DAT28 | — | — | — | 0 | 0 | 0 | 0 | 0 | 0 | 0 | 0 | — | — | 1 | 1 | | |
| 276 | 0x0268 | GPIO276 | D_ADD29 | D_ADD_DAT29 | — | — | — | 0 | 0 | 0 | 0 | 0 | 0 | 0 | 0 | — | — | 1 | 1 | | |
| 277 | 0x026A | GPIO277 | D_ADD30 | D_ADD_DAT30 | — | — | — | 0 | 0 | 0 | 0 | 0 | 0 | 0 | 0 | — | — | 1 | 1 | | |
| 278 | 0x026C | GPIO278 | D_ADD_DAT0 | — | — | — | — | 0 | 0 | 0 | 0 | 0 | 0 | 0 | 0 | — | — | 1 | 1 | | |
| 279 | 0x026E | GPIO279 | D_ADD_DAT1 | — | — | — | — | 0 | 0 | 0 | 0 | 0 | 0 | 0 | 0 | — | — | 1 | 1 | | |
| 280 | 0x0270 | GPIO280 | D_ADD_DAT2 | — | — | — | — | 0 | 0 | 0 | 0 | 0 | 0 | 0 | 0 | — | — | 1 | 1 | | |
| 281 | 0x0272 | GPIO281 | D_ADD_DAT3 | — | — | — | — | 0 | 0 | 0 | 0 | 0 | 0 | 0 | 0 | — | — | 1 | 1 | | |
| 282 | 0x0274 | GPIO282 | D_ADD_DAT4 | — | — | — | — | 0 | 0 | 0 | 0 | 0 | 0 | 0 | 0 | — | — | 1 | 1 | | |
| 283 | 0x0276 | GPIO283 | D_ADD_DAT5 | — | — | — | — | 0 | 0 | 0 | 0 | 0 | 0 | 0 | 0 | — | — | 1 | 1 | | |
| 284 | 0x0278 | GPIO284 | D_ADD_DAT6 | — | — | — | — | 0 | 0 | 0 | 0 | 0 | 0 | 0 | 0 | — | — | 1 | 1 | | |
| 285 | 0x027A | GPIO285 | D_ADD_DAT7 | — | — | — | — | 0 | 0 | 0 | 0 | 0 | 0 | 0 | 0 | — | — | 1 | 1 | | |
| 286 | 0x027C | GPIO286 | D_ADD_DAT8 | — | — | — | — | 0 | 0 | 0 | 0 | 0 | 0 | 0 | 0 | — | — | 1 | 1 | | |
| 287 | 0x027E | GPIO287 | D_ADD_DAT9 | — | — | — | — | 0 | 0 | 0 | 0 | 0 | 0 | 0 | 0 | — | — | 1 | 1 | | |
| 288 | 0x0280 | GPIO288 | D_ADD_DAT10 | — | — | — | — | 0 | 0 | 0 | 0 | 0 | 0 | 0 | 0 | — | — | 1 | 1 | | |
| 289 | 0x0282 | GPIO289 | D_ADD_DAT11 | — | — | — | — | 0 | 0 | 0 | 0 | 0 | 0 | 0 | 0 | — | — | 1 | 1 | | |
| 290 | 0x0284 | GPIO290 | D_ADD_DAT12 | — | — | — | — | 0 | 0 | 0 | 0 | 0 | 0 | 0 | 0 | — | — | 1 | 1 | | |
| 291 | 0x0286 | GPIO291 | D_ADD_DAT13 | — | — | — | — | 0 | 0 | 0 | 0 | 0 | 0 | 0 | 0 | — | — | 1 | 1 | | |
| 292 | 0x0288 | GPIO292 | D_ADD_DAT14 | — | — | — | — | 0 | 0 | 0 | 0 | 0 | 0 | 0 | 0 | — | — | 1 | 1 | | |

Table 7-22. SIU_PCRn Settings (continued)

| PCRn | Address Offset | GPIO | Primary Function | A2 | A3 | A4 | SIU_PCRn[3:15] ¹ | | | | | | | | | | | | | | |
|------|----------------|---------|------------------|--------------------|------|------|---|-----|------|------|-----|-----|---|----|----|----|----|----|----|---|--|
| | | | | | | | (SIU_PCRn[0:2] = Reserved, should be cleared) | | | | | | | | | | | | | | |
| | | | | | | | 3 | 4 | 5 | 6 | 7 | 8 | 9 | 10 | 11 | 12 | 13 | 14 | 15 | | |
| PA2 | PA1 | PA0 | OBE | IBE | DSC1 | DSC0 | ODE | HYS | SRC1 | SRC0 | WPE | WPS | | | | | | | | | |
| 293 | 0x028A | GPIO293 | D_ADD_DAT15 | — | — | — | — | — | 0 | 0 | 0 | 0 | 0 | 0 | 0 | — | — | 1 | 1 | | |
| 294 | 0x028C | GPIO294 | D_RD_WR | — | — | — | — | — | 0 | 0 | 0 | 0 | 0 | 0 | 0 | — | — | 1 | 1 | | |
| 295 | 0x028E | GPIO295 | D_WE0 | — | — | — | — | — | 0 | 0 | 0 | 0 | 0 | 0 | 0 | — | — | 1 | 1 | | |
| 296 | 0x0290 | GPIO296 | D_WE1 | — | — | — | — | — | 0 | 0 | 0 | 0 | 0 | 0 | 0 | — | — | 1 | 1 | | |
| 297 | 0x0292 | GPIO297 | D_OE | — | — | — | — | — | 0 | 0 | 0 | 0 | 0 | 0 | 0 | — | — | 1 | 1 | | |
| 298 | 0x0294 | GPIO298 | D_TS | — | — | — | — | — | 0 | 0 | 0 | 0 | 0 | 0 | 0 | — | — | 1 | 1 | | |
| 299 | 0x0296 | GPIO299 | D_ALE | — | — | — | — | — | 0 | 0 | 0 | 0 | 0 | 0 | 0 | — | — | 1 | 0 | | |
| 300 | 0x0298 | GPIO300 | D_TA | — | — | — | — | — | 0 | 0 | 0 | 0 | 0 | 0 | 0 | — | — | 1 | 1 | | |
| 301 | 0x029A | GPIO301 | D_CS1 | — | — | — | — | — | 0 | 0 | 0 | 0 | 0 | 0 | 0 | — | — | 1 | 1 | | |
| 302 | 0x029C | GPIO302 | D_BDIP | — | — | — | — | — | 0 | 0 | 0 | 0 | 0 | 0 | 0 | — | — | 1 | 1 | | |
| 303 | 0x029E | GPIO303 | D_WE2 | — | — | — | — | — | 0 | 0 | 0 | 0 | 0 | 0 | 0 | — | — | 1 | 1 | | |
| 304 | 0x02A0 | GPIO304 | D_WE3 | — | — | — | — | — | 0 | 0 | 0 | 0 | 0 | 0 | 0 | — | — | 1 | 1 | | |
| 305 | 0x02A2 | GPIO305 | D_ADD9 | — | — | — | — | — | 0 | 0 | 0 | 0 | 0 | 0 | 0 | — | — | 1 | 1 | | |
| 306 | 0x02A4 | GPIO306 | D_ADD10 | — | — | — | — | — | 0 | 0 | 0 | 0 | 0 | 0 | 0 | — | — | 1 | 1 | | |
| 307 | 0x02A6 | GPIO307 | D_ADD11 | — | — | — | — | — | 0 | 0 | 0 | 0 | 0 | 0 | 0 | — | — | 1 | 1 | | |
| 432 | 0x03A0 | GPIO432 | EMIOS26 | PCSB2 | — | — | — | — | 0 | 0 | 0 | 0 | — | — | 0 | 0 | 0 | 0 | 1 | U | |
| 433 | 0x03A2 | GPIO433 | EMIOS27 | PCSB3 | — | — | — | — | 0 | 0 | 0 | 0 | — | — | 0 | 0 | 0 | 0 | 1 | U | |
| 434 | 0x03A4 | GPIO434 | EMIOS28 | PCSC0 ⁴ | — | — | — | — | 0 | 0 | 0 | 0 | — | — | 0 | 0 | 0 | 0 | 1 | U | |
| 435 | 0x03A6 | GPIO435 | EMIOS29 | PCSC1 | — | — | — | — | 0 | 0 | 0 | 0 | — | — | 0 | 0 | 0 | 0 | 1 | U | |
| 436 | 0x03A8 | GPIO436 | EMIOS30 | PCSC2 | — | — | — | — | 0 | 0 | 0 | 0 | — | — | 0 | 0 | 0 | 0 | 1 | U | |
| 437 | 0x03AA | GPIO437 | EMIOS31 | PCSC5 | — | — | — | — | 0 | 0 | 0 | 0 | — | — | 0 | 0 | 0 | 0 | 1 | U | |
| 440 | 0x03B0 | GPIO440 | TCRCLKC | — | — | — | — | — | 0 | 0 | 0 | 0 | — | — | 0 | 0 | 0 | 0 | 1 | 1 | |
| 441 | 0x03B2 | GPIO441 | — | — | — | — | — | — | 0 | 0 | 0 | 0 | — | — | 0 | 0 | 0 | 0 | 1 | U | |

Table 7-22. SIU_PCRn Settings (continued)

| PCRn | Address Offset | GPIO | Primary Function | A2 | A3 | A4 | SIU_PCRn[3:15] ¹ | | | | | | | | | | | | | | |
|------|----------------|---------|------------------|----------------------|------|------|---|-----|------|------|-----|-----|---|----|----|----|----|----|----|--|--|
| | | | | | | | (SIU_PCRn[0:2] = Reserved, should be cleared) | | | | | | | | | | | | | | |
| | | | | | | | 3 | 4 | 5 | 6 | 7 | 8 | 9 | 10 | 11 | 12 | 13 | 14 | 15 | | |
| PA2 | PA1 | PA0 | OBE | IBE | DSC1 | DSC0 | ODE | HYS | SRC1 | SRC0 | WPE | WPS | | | | | | | | | |
| 442 | 0x03B4 | GPIO442 | — | — | — | — | — | — | 0 | 0 | 0 | — | — | 0 | 0 | 0 | 0 | 1 | U | | |
| 443 | 0x03B6 | GPIO443 | — | — | — | — | — | — | 0 | 0 | 0 | — | — | 0 | 0 | 0 | 0 | 1 | U | | |
| 444 | 0x03B8 | GPIO444 | — | — | — | — | — | — | 0 | 0 | 0 | — | — | 0 | 0 | 0 | 0 | 1 | U | | |
| 445 | 0x03BA | GPIO445 | — | — | — | — | — | — | 0 | 0 | 0 | — | — | 0 | 0 | 0 | 0 | 1 | U | | |
| 446 | 0x03BC | GPIO446 | — | — | — | — | — | — | 0 | 0 | 0 | — | — | 0 | 0 | 0 | 0 | 1 | U | | |
| 447 | 0x03BE | GPIO447 | — | — | — | — | — | — | 0 | 0 | 0 | — | — | 0 | 0 | 0 | 0 | 1 | U | | |
| 448 | 0x03C0 | GPIO448 | — | — | — | — | — | — | 0 | 0 | 0 | — | — | 0 | 0 | 0 | 0 | 1 | U | | |
| 449 | 0x03C2 | GPIO449 | — | — | — | — | — | — | 0 | 0 | 0 | — | — | 0 | 0 | 0 | 0 | 1 | U | | |
| 450 | 0x03C4 | GPIO450 | — | IRQ0 ⁴ | — | — | — | — | 0 | 0 | 0 | 0 | — | — | 0 | 0 | 0 | 1 | U | | |
| 451 | 0x03C6 | GPIO451 | — | IRQ1 ⁴ | — | — | — | — | 0 | 0 | 0 | 0 | — | — | 0 | 0 | 0 | 1 | U | | |
| 452 | 0x03C8 | GPIO452 | — | IRQ2 ⁴ | — | — | — | — | 0 | 0 | 0 | 0 | — | — | 0 | 0 | 0 | 1 | U | | |
| 453 | 0x03CA | GPIO453 | — | IRQ3 ⁴ | — | — | — | — | 0 | 0 | 0 | 0 | — | — | 0 | 0 | 0 | 1 | U | | |
| 454 | 0x03CC | GPIO454 | — | IRQ4 ⁴ | — | — | — | — | 0 | 0 | 0 | 0 | — | — | 0 | 0 | 0 | 1 | U | | |
| 455 | 0x03CE | GPIO455 | — | IRQ5 ⁴ | — | — | — | — | 0 | 0 | 0 | 0 | — | — | 0 | 0 | 0 | 1 | U | | |
| 456 | 0x03D0 | GPIO456 | — | — | — | — | — | — | 0 | 0 | 0 | 0 | — | — | 0 | 0 | 0 | 1 | U | | |
| 457 | 0x03D2 | GPIO457 | — | FR_A_TX | — | — | — | — | 0 | 0 | 0 | 0 | — | — | 0 | 0 | 0 | 1 | U | | |
| 458 | 0x03D4 | GPIO458 | — | FR_A_RX ⁴ | — | — | — | — | 0 | 0 | 0 | 0 | — | — | 0 | 0 | 0 | 1 | U | | |
| 459 | 0x03D6 | GPIO459 | — | FR_A_TX_EN | — | — | — | — | 0 | 0 | 0 | 0 | — | — | 0 | 0 | 0 | 1 | U | | |
| 460 | 0x03D8 | GPIO460 | — | TXDA ⁴ | — | — | — | — | 0 | 0 | 0 | 0 | — | — | 0 | 0 | 0 | 1 | U | | |
| 461 | 0x03DA | GPIO461 | — | RXDA ⁴ | — | — | — | — | 0 | 0 | 0 | 0 | — | — | 0 | 0 | 0 | 1 | U | | |
| 462 | 0x03DC | GPIO462 | — | TXDB ⁴ | — | — | — | — | 0 | 0 | 0 | 0 | — | — | 0 | 0 | 0 | 1 | U | | |
| 463 | 0x03DE | GPIO463 | — | RXDB ⁴ | — | — | — | — | 0 | 0 | 0 | 0 | — | — | 0 | 0 | 0 | 1 | U | | |
| 464 | 0x03E0 | GPIO464 | — | PCSD5 | MAA0 | MAB0 | 0 | 0 | 0 | 0 | 0 | — | — | 0 | 0 | 0 | 0 | 1 | U | | |

Table 7-22. SIU_PCRn Settings (continued)

| PCRn | Address Offset | GPIO | Primary Function | A2 | A3 | A4 | SIU_PCRn[3:15] ¹ | | | | | | | | | | | | | | |
|------|----------------|---------|------------------|--------------------|------|------|---|-----|------|------|-----|-----|---|----|----|----|----|----|----|--|--|
| | | | | | | | (SIU_PCRn[0:2] = Reserved, should be cleared) | | | | | | | | | | | | | | |
| | | | | | | | 3 | 4 | 5 | 6 | 7 | 8 | 9 | 10 | 11 | 12 | 13 | 14 | 15 | | |
| PA2 | PA1 | PA0 | OBE | IBE | DSC1 | DSC0 | ODE | HYS | SRC1 | SRC0 | WPE | WPS | | | | | | | | | |
| 465 | 0x03E2 | GPIO465 | — | PCSD4 | MAA1 | MAB1 | 0 | 0 | 0 | 0 | 0 | — | — | 0 | 0 | 0 | 0 | 1 | U | | |
| 466 | 0x03E4 | GPIO466 | — | PCSD3 | MAA2 | MAB2 | 0 | 0 | 0 | 0 | 0 | — | — | 0 | 0 | 0 | 0 | 1 | U | | |
| 467 | 0x03E6 | GPIO467 | — | PCSD2 | — | — | — | 0 | 0 | 0 | 0 | — | — | 0 | 0 | 0 | 0 | 1 | U | | |
| 468 | 0x03E8 | GPIO468 | — | PCSD1 | — | — | — | 0 | 0 | 0 | 0 | — | — | 0 | 0 | 0 | 0 | 1 | U | | |
| 469 | 0x03EA | GPIO469 | — | PCSD0 ⁴ | — | — | — | 0 | 0 | 0 | 0 | — | — | 0 | 0 | 0 | 0 | 1 | U | | |
| 470 | 0x03EC | GPIO470 | — | SCKD ⁴ | — | — | — | 0 | 0 | 0 | 0 | — | — | 0 | 0 | 0 | 0 | 1 | U | | |
| 471 | 0x03EE | GPIO471 | — | SOUTD | — | — | — | 0 | 0 | 0 | 0 | — | — | 0 | 0 | 0 | 0 | 1 | U | | |
| 472 | 0X03F0 | GPIO472 | — | SIND ⁴ | — | — | — | 0 | 0 | 0 | 0 | — | — | 0 | 0 | 0 | 0 | 1 | U | | |

¹ “—” means the field is not implemented in the PCR (and a default value of 0 should be written)

“U” means the field is defined by the WKPCFG pin at reset

² PCR75–PCR82: reduced port mode MDO pins, only DSC bits should be driven by PCR (also IBE and OBE for GPIO).

³ GPIO functionality available on Rev.2 of the device.

⁴ Selection of this function may be affected by a higher priority PCR. See [Table 7-21](#).

⁵ When the SIU_ISEL8 register is in its default state, this eTPU pin will not be enabled as an input, irrespective of the SIU_PCR[PA] field.

⁶ PCR231–PCR234: PA are controlled by Nexus Port Controller (NPC). The Full Port Mode (FPM) bit in the NPC pad configuration register controls whether the pins function as MDO or GPIO. The pad interface port enable is driven by the NPC block. When the FPM bit is set, the NPC enables the MDO port enable, and disables GPIO. When the FPM bit is cleared, the NPC disables the MDO port enable, and enables GPIO.

- The OBE bit applies only to GPIO operation
- Clear the ODE bit to 0 for MDO operation
- The HYS bit has no effect on MDO operation
- Clear the WPE bit to 0 for MDO operation

⁷ Bit = 1 only for Rev.2 of the device.

7.3.1.14 GPIO Pin Data Output Registers 0–512 (SIU_GPDO_n)

The 8-bit SIU_GPDO_n registers defined in [Figure 7-15](#) each specify the output data for the function assigned to the GPIO[*n*] pin. The *n* notation in the SIU_GPDO_n register name relate to the [*n*] in GPIO[*n*] signal name. For example, SIU_GPDO246 contains the PDO246 bit for CNTXD_GPIO246. The address for a GPDO pin is the GPIO number plus an offset of SIU_BASE + 0x0600.

Software writes to the SIU_GPDO_n registers to drive data out on the external pin. Each register drives one external pin, which allows independent control of the pin. Writes to the SIU_GPDO_n registers have no effect if an input function is assigned to the pin by the pad configuration register.

If the direction of a GPIO signal changes from input to output, the SIU_GPDO_n register value is automatically driven out to the external pin without a software update.

Writes to the SIU_GPDO_n registers have no effect when a primary or alternate function is assigned (except you can read the value back that was just written).

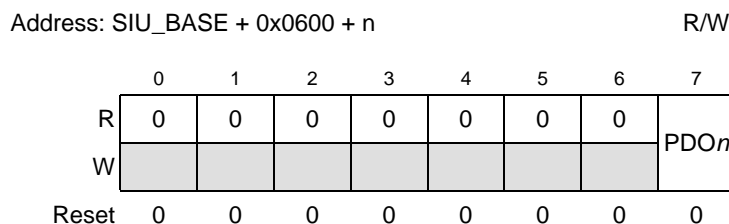

Figure 7-15. General Purpose Data Output (GPDO) Registers 0–512 (SIU_GPDO_n)

Table 7-23. SIU_GPDO Bit Field Descriptions

| Field | Description |
|-----------------------|--|
| 0–6 | Reserved |
| 7 PDO _n | Pin data out. Stores the data to drive out the external GPIO. If the register is read, it returns the value written. 0 A logic 0 is driven on the external GPIO pin when the pin is configured as an output. 1 A logic 1 is driven on the external GPIO pin when the pin is configured as an output. |

7.3.1.15 GPIO Pin Data Input Registers 0–255 (SIU_GPDI_n)

NOTE

This register is implemented for legacy purposes and is limited to 256 general purpose input registers. For full access to all 512 general purpose input registers, the SIU_GPDI_n registers in [Section 7.3.1.35, GPIO Pin Data Input Registers \(SIU_GPDI0_3 - SIU_GPDI508_511\) - Standard](#), should be used.

The 8-bit read-only SIU_GPDI_n registers defined in [Figure 7-16](#) each specify the input state for the function assigned to the GPDI[*n*] pin. The *n* notation in the SIU_GPDI_n register name relates to the [*n*] in GPIO[*n*] signal name. For example, SIU_GPDI246 contains the PDI246 bit for CNTXD_GPIO246. The

GPDI address for a particular pin is the GPIO number plus an offset of $SIU_BASE + 0x0800$. Gaps exist in the memory where GPIO pins are not implemented in the package.

Software reads the SIU_GPDIn registers to get the input state of the external GPIO pin. Each GPDI register contains the input state of one external GPIO pin. If a GPDI register is configured as output, and the input buffer enable bit is set to one in the PCR register, the SIU_GPDIn register reflects the state of the output pin.

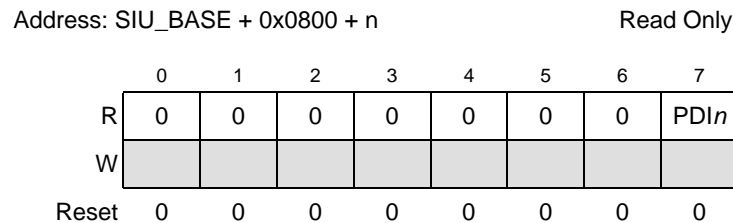

Figure 7-16. General Purpose Data Input (GPDI) Registers 0–255 (SIU_GPDIn)

Table 7-24. SIU_GPDIn Bit Field Descriptions

| Field | Description |
|--------------|--|
| 0–6 | Reserved |
| 7 PDI_n | Pin data in. This bit reflects the input state on the external GPIO pin for the register. If $PCR_n[IBE] = 1$, then: 0 Signal on pin is a logic 0. 1 Signal on pin is a logic 1. |

7.3.1.16 External IRQ Input Select Register (SIU_EIISR)

The SIU_EIISR selects the source for the external interrupt/DMA inputs.

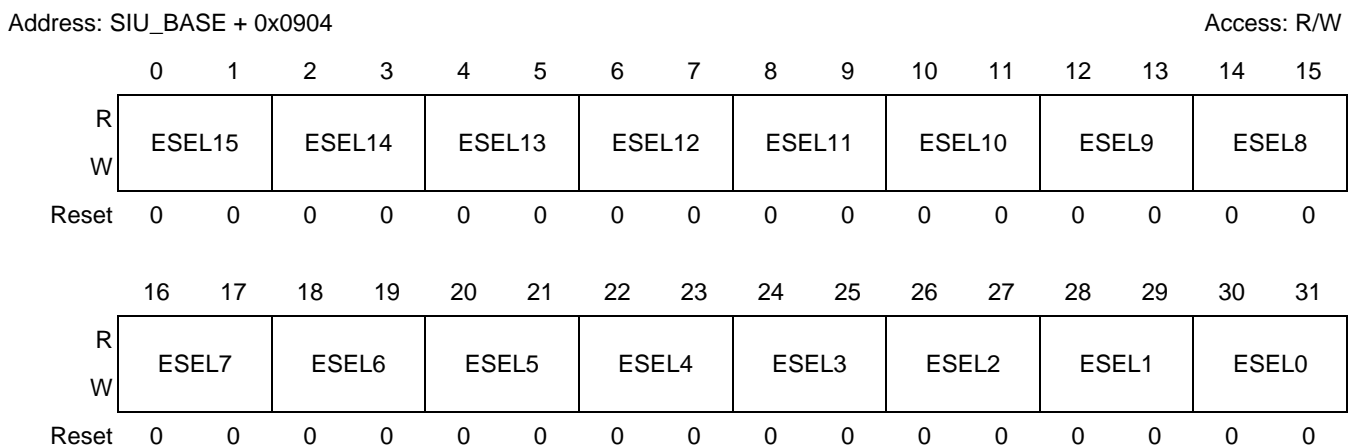

Figure 7-17. External IRQ Input Select Register (SIU_EIISR)

The following table describes the external IRQ input select fields:

Table 7-25. SIU_EISR Bit Field Descriptions

| Field | Description |
|-----------------|---|
| 0–1 ESEL15 | External IRQ input select 15. Specifies the input for $\overline{\text{IRQ}}[15]$. 00 $\overline{\text{IRQ}}[15]$ pin 01 DSPI_B[15] deserialized input 10 DSPI_C[0] deserialized input 11 DSPI_D[1] deserialized input |
| 2–3 ESEL14 | External IRQ input select 14. Specifies the input for $\overline{\text{IRQ}}[14]$. 00 $\overline{\text{IRQ}}[14]$ pin 01 DSPI_B[14] deserialized input 10 DSPI_C[15] deserialized input 11 DSPI_D[0] deserialized input |
| 4–5 ESEL13 | External IRQ input select 13. Specifies the input for $\overline{\text{IRQ}}[13]$. 00 $\overline{\text{IRQ}}[13]$ pin 01 DSPI_B[13] deserialized input 10 DSPI_C[14] deserialized input 11 DSPI_D[15] deserialized input |
| 6–7 ESEL12 | External IRQ input select 12. Specifies the input for $\overline{\text{IRQ}}[12]$. 00 $\overline{\text{IRQ}}[12]$ pin 01 DSPI_B[12] deserialized input 10 DSPI_C[13] deserialized input 11 DSPI_D[14] deserialized input |
| 8–9 ESEL11 | External IRQ input select 11. Specifies the input for $\overline{\text{IRQ}}[11]$. 00 $\overline{\text{IRQ}}[11]$ pin 01 DSPI_B[11] deserialized input 10 DSPI_C[12] deserialized input 11 DSPI_D[13] deserialized input |
| 10–11 ESEL10 | External IRQ input select 10. Specifies the input for $\overline{\text{IRQ}}[10]$. 00 $\overline{\text{IRQ}}[10]$ pin 01 DSPI_B[10] deserialized input 10 DSPI_C[11] deserialized input 11 DSPI_D[12] deserialized input |
| 12–13 ESEL9 | External IRQ input select 9. Specifies the input for $\overline{\text{IRQ}}[9]$. 00 $\overline{\text{IRQ}}[9]$ pin 01 DSPI_B[9] deserialized input 10 DSPI_C[10] deserialized input 11 DSPI_D[11] deserialized input |
| 14–15 ESEL8 | External IRQ input select 8. Specifies the input for $\overline{\text{IRQ}}[8]$. 00 $\overline{\text{IRQ}}[8]$ pin 01 DSPI_B[8] deserialized input 10 DSPI_C[9] deserialized input 11 DSPI_D[10] deserialized input |
| 16–17 ESEL7 | External IRQ input select 7. Specifies the input for $\overline{\text{IRQ}}[7]$. 00 $\overline{\text{IRQ}}[7]$ pin 01 DSPI_B[7] deserialized input 10 DSPI_C[8] deserialized input 11 DSPI_D[9] deserialized input |

Table 7-25. SIU_EISR Bit Field Descriptions (continued)

| Field | Description |
|----------------|---|
| 18–19 ESEL6 | External IRQ input select 6. Specifies the input for $\overline{\text{IRQ}}[6]$. 00 $\overline{\text{IRQ}}[6]$ pin 01 DSPI_B[6] deserialized input 10 DSPI_C[7] deserialized input 11 DSPI_D[8] deserialized input |
| 20–21 ESEL5 | External IRQ input select 5. Specifies the input for $\overline{\text{IRQ}}[5]$. 00 $\overline{\text{IRQ}}[5]$ pin 01 DSPI_B[5] deserialized input 10 DSPI_C[6] deserialized input 11 DSPI_D[7] deserialized input |
| 22–23 ESEL4 | External IRQ input select 4. Specifies the input for $\overline{\text{IRQ}}[4]$. 00 $\overline{\text{IRQ}}[4]$ pin 01 DSPI_B[5] deserialized input 10 DSPI_C[6] deserialized input 11 DSPI_D[1] deserialized input |
| 24–25 ESEL3 | External IRQ input select 3. Specifies the input for $\overline{\text{IRQ}}[3]$. 00 $\overline{\text{IRQ}}[3]$ pin 01 DSPI_B[3] deserialized input 10 DSPI_C[4] deserialized input 11 DSPI_D[5] deserialized input |
| 26–27 ESEL2 | External IRQ input select 2. Specifies the input for $\overline{\text{IRQ}}[2]$. 00 $\overline{\text{IRQ}}[2]$ pin 01 DSPI_B[2] deserialized input 10 DSPI_C[3] deserialized input 11 DSPI_D[4] deserialized input |
| 28–29 ESEL1 | External IRQ input select 1. Specifies the input for $\overline{\text{IRQ}}[1]$. 00 $\overline{\text{IRQ}}[1]$ pin 01 DSPI_B[1] deserialized input 10 DSPI_C[2] deserialized input 11 eMIOS channel 15 output |
| 30–31 ESEL0 | External IRQ input select 0. Specifies the input for $\overline{\text{IRQ}}[0]$. 00 $\overline{\text{IRQ}}[0]$ pin 01 DSPI_B[0] deserialized input 10 DSPI_C[1] deserialized input 11 eMIOS channel 14 output |

7.3.1.17 DSPI Input Select Register (SIU_DISR)

The SIU_DISR specifies the following operations for each DSPI:

- Data input source
- Slave select
- Clock input

Trigger input to allow serial and parallel chaining of the DSPI modules.

Address: SIU_BASE + 0x0908

Access: R/W

| | | | | | | | | | | | | | | | | |
|-------|---------|----|-------|----|---------|----|----------|----|---------|----|--------|----|----------|----|-----------|----|
| | 0 | 1 | 2 | 3 | 4 | 5 | 6 | 7 | 8 | 9 | 10 | 11 | 12 | 13 | 14 | 15 |
| R | SINSELA | | SSELA | | SCKSELA | | TRIGSELA | | SINSELB | | SSELB | | SCKSELB | | TRIGSELB | |
| W | SINSELA | | SSELA | | SCKSELA | | TRIGSELA | | SINSELB | | SSELB | | SCKSELB | | TRIGSELB | |
| Reset | 0 | 0 | 0 | 0 | 0 | 0 | 0 | 0 | 0 | 0 | 0 | 0 | 0 | 0 | 0 | 0 |
| | 16 | 17 | 18 | 19 | 20 | 21 | 22 | 23 | 24 | 25 | 26 | 27 | 28 | 29 | 30 | 31 |
| R | SINSELC | | SSELC | | SCKSELC | | TRIGSELC | | SINSELD | | SSELCD | | SCKSELCD | | TRIGSELCD | |
| W | SINSELC | | SSELC | | SCKSELC | | TRIGSELC | | SINSELD | | SSELCD | | SCKSELCD | | TRIGSELCD | |
| Reset | 0 | 0 | 0 | 0 | 0 | 0 | 0 | 0 | 0 | 0 | 0 | 0 | 0 | 0 | 0 | 0 |

Figure 7-18. DSPI Input Select Register (SIU_DISR)

The following table describes the DSPI input select fields:

Table 7-26. SIU_DISR Bit Field Descriptions

| Field | Description |
|-----------------|--|
| 0–1 SINSELA | DSPI A data input select. Specifies the source of the DSPI A data input. 00 SINA_PCSC[2]_GPIO[94] pin 01 SOUTB 10 SOUTC 11 SOUTD |
| 2–3 SSELA | DSPI A slave select input select. Specifies the source of the DSPI A slave select input. 00 PCSA[0]_PCSD[2]_GPIO[96] pin 01 PCSB[0] (master) 10 PCSC[0] (master) 11 PCSD[0] (master) |
| 4–5 SCKSELA | DSPI A clock input select. Specifies the source of the DSPI A clock input. 00 SCKA_PCSC[1]_GPIO[93] pin 01 SCKB (master) 10 SCKC (master) 11 SCKD (master) |
| 6–7 TRIGSELA | DSPI A trigger input select. Specifies the source of the DSPI A trigger input. 00 No Trigger 01 PCSB[4] 10 PCSC[4] 11 PCSD[4] |
| 8–9 SINSELB | DSPI B data input select. Specifies the source of DSPI B data input. 00 SINB_GPIO[103] pin 01 SOUTA 10 SOUTC 11 SOUTD |

Table 7-26. SIU_DISR Bit Field Descriptions (continued)

| Field | Description |
|-------------------|---|
| 10–11 SSSELB | DSPI B slave select input select. Specifies the source of the DSPI B slave select input. 00 PCSB[0]_PCSD[2]_GPIO[105] pin 01 PCSA[0] (master) 10 PCSC[0] (master) 11 PCSD[0] (master) |
| 12–13 SCKSELB | DSPI B clock input select. Specifies the source of the DSPI B clock input. 00 SCKB_GPIO[102] pin 01 SCKA (master) 10 SCKC (master) 11 SCKD (master) |
| 14–15 TRIGSELB | DSPI B trigger input select. Specifies the source of the DSPI B trigger input for master or slave mode. 00 Invalid value 01 PCSA[4] 10 PCSC[4] 11 PCSD[4] |
| 16–17 SINSELC | DSPI C data input select. Specifies the source of the DSPI C data input. 00 PCSB[3]_SINC_GPIO[108] pin 01 SOUTA 10 SOUTB 11 SOUTD |
| 18–19 SSELC | DSPI C slave select input select. Specifies the source of the DSPI C slave select input. 00 PCSB[5]_PCSC[0]_GPIO[110] pin 01 PCSA[0] (master) 10 PCSB[0] (master) 11 PCSD[0] (master) |
| 20–21 SCKSELC | DSPI C clock input select. Specifies the source of the DSPI C clock input when in slave mode. 00 PCSB[4]_SCKC_GPIO[109] pin 01 SCKA (master) 10 SCKB (master) 11 SCKD (master) |
| 22–23 TRIGSELC | DSPI C trigger input select. Specifies the source of the DSPI C trigger input for master or slave mode. 00 Invalid value 01 PCSA[4] 10 PCSB[4] 11 PCSD[4] |
| 24–25 SINSELD | DSPI D data input select. Specifies the source of the DSPI D data input. 00 PCSA[3]_GPIO[99] pin 01 SOUTA 10 SOUTB 11 SOUTC |

Table 7-26. SIU_DISR Bit Field Descriptions (continued)

| Field | Description |
|-------------------|---|
| 26–27 SSSELD | DSPI D slave select input select. Specifies the source of the DSPI D slave select input. 00 PCSB[1]_PCSD[0]_GPIO[106] pin 01 PCSA0 (master) 10 PCSB0 (master) 11 PCSC0 (master) |
| 28–29 SCKSELD | DSPI D clock input select. Specifies the source of the DSPI D clock input in slave mode. 00 PCSA[2]_SCKD_GPIO[98] pin 01 Invalid value 10 SCKB (master) 11 SCKC (master) |
| 30–31 TRIGSELD | DSPI D trigger input select. Specifies the source of the DSPI D trigger input for master or slave mode. 00 Invalid value 01 PCSA4 10 PCSB4 11 PCSC4 |

7.3.1.18 eQADC Command FIFO Trigger Source Select - IMUX Select Registers (SIU_ISEL[4-7])

The IMUX select registers (SIU_ISEL[4 -7]) are used to select a trigger source for a command FIFO. SIU_ISEL select registers [4:5] are used to select a trigger source for command FIFOs in one eQADC. SIU_ISEL select registers [6:7] are used to select a trigger source for command FIFOs in a second eQADC. The cTSEL (combined Trigger Select) field is used to configure one of many possible trigger sources for each command FIFO.

To trigger the eQADC, the trigger source must change to the state that the input to the command FIFO has been programmed to recognize. A command FIFO trigger input can be programmed to recognize either rising or falling edges, and low or high gated trigger types.

SIU_ISEL4: eTRIG_A[5:2]

Address: SIU_BASE + 0x0910

Access: R/W

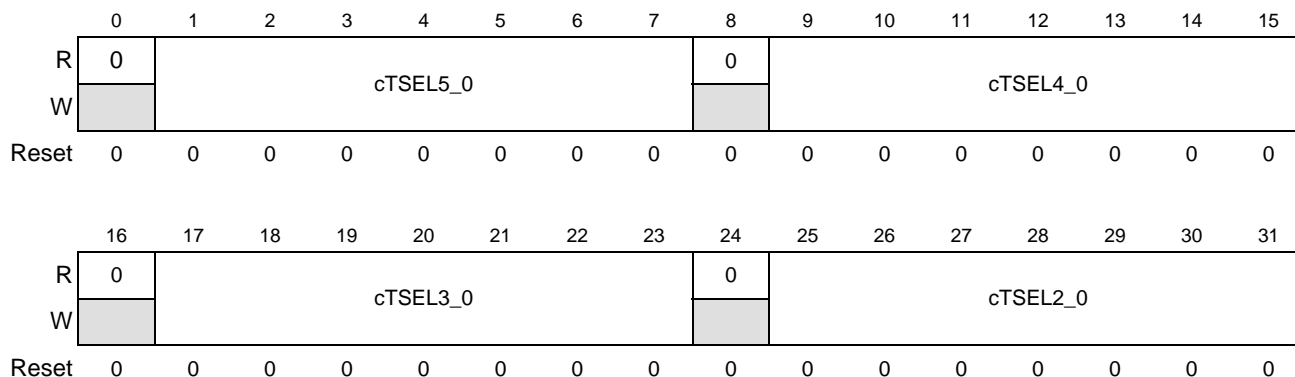

SIU_ISEL5: eTRIG_A[1:0]

Address: SIU_BASE + 0x0914

Access: R/ W

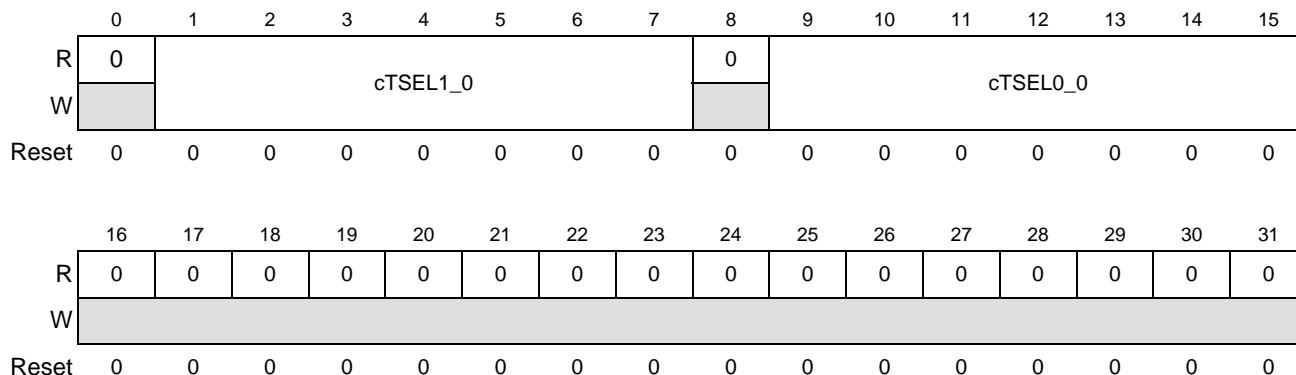

SIU_ISEL6: eTRIG_B[5:2]

Address: SIU_BASE + 0x0918

Access: R/ W

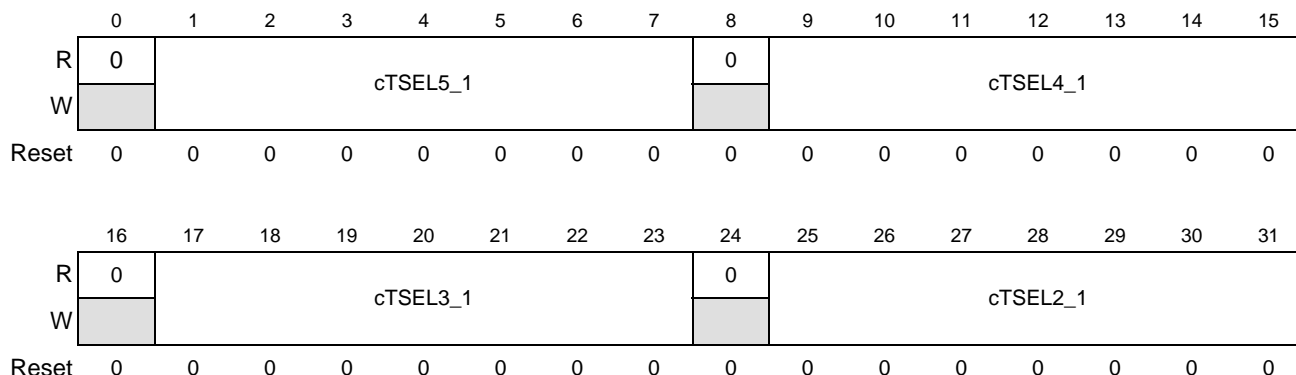

SIU_ISEL7: eTRIG_B[1:0]

Address: SIU_BASE + 0x091C

Access: R/ W

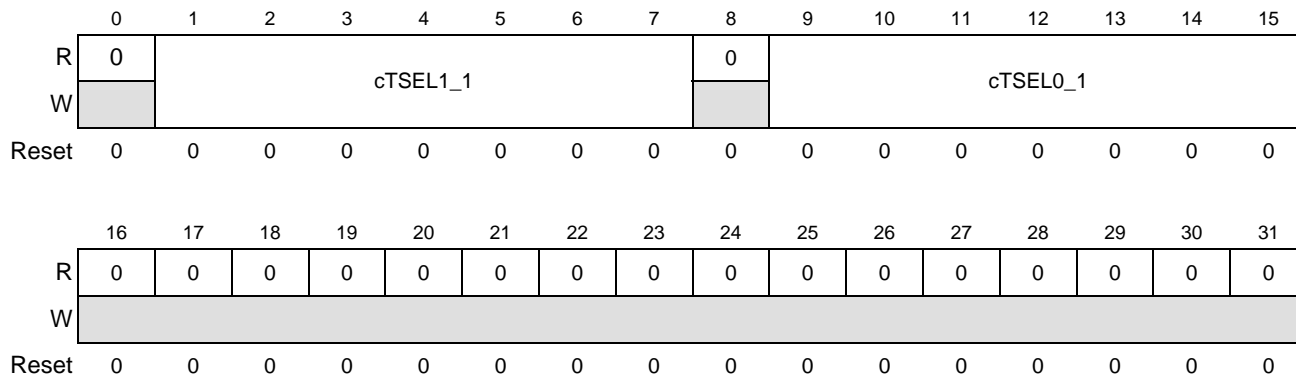

Table 7-27. eQADC_A Command FIFO 0 Trigger Sources

| eTSEL | cTSEL0_0 | | | | | eQADC_A Trigger Inputs |
|-------|----------|---|---|---|---------|-------------------------|
| | 0 | 0 | | | | |
| eTSEL | 0 | 0 | 0 | 0 | 0 | Not Connected (default) |
| | | | 0 | 0 | 1 | RTI Trigger |
| | | | 0 | 1 | 0 | PIT0 Trigger |
| | | | 0 | 1 | 1 | PIT1 Trigger |
| | | | 1 | 0 | 0 | PIT2 Trigger |
| | | | 1 | 0 | 1 | PIT3 Trigger |
| | | | 1 | 1 | 0 | Reserved |
| | | | 1 | 1 | 1 | eTRIG1 pin |
| | | | 1 | 0 | x | Reserved |
| | | | 1 | 1 | 0 | eTPUA28 |
| | | | 1 | 1 | 1 | eTPUA29 |
| | | | 1 | 1 | 0 | eTPUA30 |
| | | | 1 | 1 | 1 | eTPUA31 |
| | | | 1 | 0 | 0 | eTPUB28 |
| | | | 1 | 0 | 1 | eTPUB29 |
| | | | 1 | 0 | 0 | eTPUB30 |
| | | | 1 | 0 | 1 | eTPUB31 |
| | | | 1 | 0 | 0 | Reserved |
| | | | 1 | 0 | 1 | Reversed |
| | | | 1 | 0 | 1 | Reserved |
| | | | 1 | 0 | 1 | Reserved |
| | | | 1 | 1 | 0 | eMIOS16 |
| | | | 1 | 1 | 0 | eMIOS17 |
| | | | 1 | 1 | 0 | eMIOS18 |
| | | | 1 | 1 | 0 | eMIOS19 |
| | | | 1 | 1 | 1 | eMIOS20 |
| | | | 1 | 1 | 1 | eMIOS21 |
| | | 1 | 1 | 1 | eMIOS22 | |
| | | 1 | 1 | 1 | eMIOS23 | |
| eTPU | 0 | 1 | x | x | x | eTPUA30 |
| eMIOS | 1 | 0 | x | x | x | eMIOS10 |
| eTRIG | 1 | 1 | x | x | x | ETRIG0 Pin |

Table 7-28. eQADC_A Command FIFO 1 Trigger Sources

| eTSEL | cTSEL1_0 | | | | | eQADC_A Trigger Inputs | |
|-------|----------|---|---|---|---|-------------------------|----------|
| | 0 | 0 | | | | | |
| eTSEL | 0 | 0 | 0 | 0 | 0 | Not Connected (default) | |
| | | | 0 | 0 | 1 | RTI Trigger | |
| | | | 0 | 1 | 0 | PIT0 Trigger | |
| | | | 0 | 1 | 1 | PIT1 Trigger | |
| | | | 1 | 0 | 0 | PIT2 Trigger | |
| | | | 1 | 0 | 1 | PIT3 Trigger | |
| | | | 1 | 1 | 0 | eTPUA7 | |
| | | | 1 | 1 | 1 | eTRIG0 pin | |
| | | 0 | 1 | 0 | x | x | Reserved |
| | | 0 | 1 | 1 | 0 | 0 | eTPUA28 |
| | | 0 | 1 | 1 | 0 | 1 | eTPUA29 |
| | | 0 | 1 | 1 | 1 | 0 | eTPUA30 |
| | | 0 | 1 | 1 | 1 | 1 | eTPUA31 |
| | | 1 | 0 | 0 | 0 | 0 | eTPUB28 |
| | | 1 | 0 | 0 | 0 | 1 | eTPUB29 |
| | | 1 | 0 | 0 | 1 | 0 | eTPUB30 |
| | | 1 | 0 | 0 | 1 | 1 | eTPUB31 |
| | | 1 | 0 | 1 | 0 | 0 | Reserved |
| | | 1 | 0 | 1 | 0 | 1 | Reversed |
| | | 1 | 0 | 1 | 1 | 0 | Reserved |
| | | 1 | 0 | 1 | 1 | 1 | Reserved |
| | | 1 | 1 | 0 | 0 | 0 | eMIOS16 |
| | | 1 | 1 | 0 | 0 | 1 | eMIOS17 |
| | | 1 | 1 | 0 | 1 | 0 | eMIOS18 |
| | | 1 | 1 | 0 | 1 | 1 | eMIOS19 |
| | | 1 | 1 | 1 | 0 | 0 | eMIOS20 |
| | | 1 | 1 | 1 | 0 | 1 | eMIOS21 |
| | 1 | 1 | 1 | 1 | 0 | eMIOS22 | |
| | 1 | 1 | 1 | 1 | 1 | eMIOS23 | |
| eTPU | 0 | 1 | | | | eTPUA31 | |
| eMIOS | 1 | 0 | | | | eMIOS11 | |
| eTRIG | 1 | 1 | | | | ETRIG1 Pin | |

Table 7-29. eQADC_A Command FIFO 2 Trigger Sources

| eTSEL | cTSEL2_0 | | | | | eQADC_A Trigger Inputs |
|-------|----------|---|---|---|---------|-------------------------|
| | 0 | 0 | | | | |
| eTSEL | 0 | 0 | 0 | 0 | 0 | Not Connected (default) |
| | | | 0 | 0 | 1 | RTI Trigger |
| | | | 0 | 1 | 0 | PIT0 Trigger |
| | | | 0 | 1 | 1 | PIT1 Trigger |
| | | | 0 | 1 | 0 | PIT2 Trigger |
| | | | 0 | 1 | 1 | PIT3 Trigger |
| | | | 0 | 1 | 0 | eTPUA14 |
| | | | 0 | 1 | 1 | eTRIG1 pin |
| | | | 0 | 1 | 0 | Reserved |
| | | | 0 | 1 | 1 | eTPUA28 |
| | | | 0 | 1 | 0 | eTPUA29 |
| | | | 0 | 1 | 1 | eTPUA30 |
| | | | 0 | 1 | 1 | eTPUA31 |
| | | | 1 | 0 | 0 | eTPUB28 |
| | | | 1 | 0 | 1 | eTPUB29 |
| | | | 1 | 0 | 0 | eTPUB30 |
| | | | 1 | 0 | 1 | eTPUB31 |
| | | | 1 | 0 | 0 | Reserved |
| | | | 1 | 0 | 1 | Reversed |
| | | | 1 | 0 | 1 | Reserved |
| | | | 1 | 0 | 1 | Reserved |
| | | | 1 | 1 | 0 | eMIOS16 |
| | | | 1 | 1 | 0 | eMIOS17 |
| | | | 1 | 1 | 0 | eMIOS18 |
| | | | 1 | 1 | 0 | eMIOS19 |
| | | | 1 | 1 | 1 | eMIOS20 |
| | | | 1 | 1 | 1 | eMIOS21 |
| | | 1 | 1 | 1 | eMIOS22 | |
| | | 1 | 1 | 1 | eMIOS23 | |
| eTPU | 0 | 1 | | | | eTPUA29 |
| eMIOS | 1 | 0 | | | | eMIOS15 |
| eTRIG | 1 | 1 | | | | ETRIG0 Pin |

Table 7-30. eQADC_A Command FIFO 3 Trigger Sources

| eTSEL | cTSEL3_0 | | | | | eQADC_A Trigger Inputs | | |
|-------|----------|---|---|---|---------|-------------------------|---|--------------|
| | 0 | 0 | | | | | | |
| eTSEL | 0 | 0 | 0 | 0 | 0 | Not Connected (default) | | |
| | | | 0 | 0 | 0 | 0 | 1 | RTI Trigger |
| | | | 0 | 0 | 0 | 1 | 0 | PIT0 Trigger |
| | | | 0 | 0 | 0 | 1 | 1 | PIT1 Trigger |
| | | | 0 | 0 | 1 | 0 | 0 | PIT2 Trigger |
| | | | 0 | 0 | 1 | 0 | 1 | PIT3 Trigger |
| | | | 0 | 0 | 1 | 1 | 0 | eTPUA22 |
| | | | 0 | 0 | 1 | 1 | 1 | eTRIG0 pin |
| | | | 0 | 1 | 0 | x | x | Reserved |
| | | | 0 | 1 | 1 | 0 | 0 | eTPUA28 |
| | | | 0 | 1 | 1 | 0 | 1 | eTPUA29 |
| | | | 0 | 1 | 1 | 1 | 0 | eTPUA30 |
| | | | 0 | 1 | 1 | 1 | 1 | eTPUA31 |
| | | | 1 | 0 | 0 | 0 | 0 | eTPUB28 |
| | | | 1 | 0 | 0 | 0 | 1 | eTPUB29 |
| | | | 1 | 0 | 0 | 1 | 0 | eTPUB30 |
| | | | 1 | 0 | 0 | 1 | 1 | eTPUB31 |
| | | | 1 | 0 | 1 | 0 | 0 | Reserved |
| | | | 1 | 0 | 1 | 0 | 1 | Reversed |
| | | | 1 | 0 | 1 | 1 | 0 | Reserved |
| | | | 1 | 0 | 1 | 1 | 1 | Reserved |
| | | | 1 | 1 | 0 | 0 | 0 | eMIOS16 |
| | | | 1 | 1 | 0 | 0 | 1 | eMIOS17 |
| | | | 1 | 1 | 0 | 1 | 0 | eMIOS18 |
| | | | 1 | 1 | 0 | 1 | 1 | eMIOS19 |
| | | | 1 | 1 | 1 | 0 | 0 | eMIOS20 |
| | | | 1 | 1 | 1 | 0 | 1 | eMIOS21 |
| 1 | 1 | 1 | 1 | 0 | eMIOS22 | | | |
| 1 | 1 | 1 | 1 | 1 | eMIOS23 | | | |
| eTPU | 0 | 1 | x | x | x | eTPUA28 | | |
| eMIOS | 1 | 0 | x | x | x | eMIOS14 | | |
| eTRIG | 1 | 1 | x | x | x | ETRIG1 Pin | | |

Table 7-31. eQADC_A Command FIFO 4 Trigger Sources

| eTSEL | cTSEL4_0 | | | | | eQADC_A Trigger Inputs | |
|-------|----------|---|---|---|---|-------------------------|----------|
| | 0 | 0 | | | | | |
| eTSEL | 0 | 0 | 0 | 0 | 0 | Not Connected (default) | |
| | | | 0 | 0 | 1 | RTI Trigger | |
| | | | 0 | 1 | 0 | PIT0 Trigger | |
| | | | 0 | 1 | 1 | PIT1 Trigger | |
| | | | 1 | 0 | 0 | PIT2 Trigger | |
| | | | 1 | 0 | 1 | PIT3 Trigger | |
| | | | 1 | 1 | 0 | eTPUA30 | |
| | | | 1 | 1 | 1 | eTRIG1 pin | |
| | | 0 | 1 | 0 | x | x | Reserved |
| | | 0 | 1 | 1 | 0 | 0 | eTPUA28 |
| | | 0 | 1 | 1 | 0 | 1 | eTPUA29 |
| | | 0 | 1 | 1 | 1 | 0 | eTPUA30 |
| | | 0 | 1 | 1 | 1 | 1 | eTPUA31 |
| | | 1 | 0 | 0 | 0 | 0 | eTPUB28 |
| | | 1 | 0 | 0 | 0 | 1 | eTPUB29 |
| | | 1 | 0 | 0 | 1 | 0 | eTPUB30 |
| | | 1 | 0 | 0 | 1 | 1 | eTPUB31 |
| | | 1 | 0 | 1 | 0 | 0 | Reserved |
| | | 1 | 0 | 1 | 0 | 1 | Reversed |
| | | 1 | 0 | 1 | 1 | 0 | Reserved |
| | | 1 | 0 | 1 | 1 | 1 | Reserved |
| | | 1 | 1 | 0 | 0 | 0 | eMIOS16 |
| | | 1 | 1 | 0 | 0 | 1 | eMIOS17 |
| | | 1 | 1 | 0 | 1 | 0 | eMIOS18 |
| | | 1 | 1 | 0 | 1 | 1 | eMIOS19 |
| | | 1 | 1 | 1 | 0 | 0 | eMIOS20 |
| | | 1 | 1 | 1 | 0 | 1 | eMIOS21 |
| | 1 | 1 | 1 | 1 | 0 | eMIOS22 | |
| | 1 | 1 | 1 | 1 | 1 | eMIOS23 | |
| eTPU | 0 | 1 | | | | eTPUA27 | |
| eMIOS | 1 | 0 | | | | eMIOS13 | |
| eTRIG | 1 | 1 | | | | ETRIG0 Pin | |

Table 7-32. eQADC_A Command FIFO 5 Trigger Sources

| eTSEL | cTSEL5_0 | | | | | eQADC_A Trigger Inputs | | |
|-------|----------|---|---|---|---------|-------------------------|---|--------------|
| | 0 | 0 | 0 | 0 | 0 | | | |
| eTSEL | 0 | 0 | 0 | 0 | 0 | Not Connected (default) | | |
| | | | 0 | 0 | 0 | 0 | 1 | RTI Trigger |
| | | | 0 | 0 | 0 | 1 | 0 | PIT0 Trigger |
| | | | 0 | 0 | 0 | 1 | 1 | PIT1 Trigger |
| | | | 0 | 0 | 1 | 0 | 0 | PIT2 Trigger |
| | | | 0 | 0 | 1 | 0 | 1 | PIT3 Trigger |
| | | | 0 | 0 | 1 | 1 | 0 | Reserved |
| | | | 0 | 0 | 1 | 1 | 1 | eTRIG0 pin |
| | | | 0 | 1 | 0 | x | x | Reserved |
| | | | 0 | 1 | 1 | 0 | 0 | eTPUA28 |
| | | | 0 | 1 | 1 | 0 | 1 | eTPUA29 |
| | | | 0 | 1 | 1 | 1 | 0 | eTPUA30 |
| | | | 0 | 1 | 1 | 1 | 1 | eTPUA31 |
| | | | 1 | 0 | 0 | 0 | 0 | eTPUB28 |
| | | | 1 | 0 | 0 | 0 | 1 | eTPUB29 |
| | | | 1 | 0 | 0 | 1 | 0 | eTPUB30 |
| | | | 1 | 0 | 0 | 1 | 1 | eTPUB31 |
| | | | 1 | 0 | 1 | 0 | 0 | Reserved |
| | | | 1 | 0 | 1 | 0 | 1 | Reversed |
| | | | 1 | 0 | 1 | 1 | 0 | Reserved |
| | | | 1 | 0 | 1 | 1 | 1 | Reserved |
| | | | 1 | 1 | 0 | 0 | 0 | eMIOS16 |
| | | | 1 | 1 | 0 | 0 | 1 | eMIOS17 |
| 1 | 1 | 0 | 1 | 0 | eMIOS18 | | | |
| 1 | 1 | 0 | 1 | 1 | eMIOS19 | | | |
| 1 | 1 | 1 | 0 | 0 | eMIOS20 | | | |
| 1 | 1 | 1 | 0 | 1 | eMIOS21 | | | |
| 1 | 1 | 1 | 1 | 0 | eMIOS22 | | | |
| 1 | 1 | 1 | 1 | 1 | eMIOS23 | | | |
| eTPU | 0 | 1 | x | x | x | eTPUA26 | | |
| eMIOS | 1 | 0 | x | x | x | eMIOS12 | | |
| eTRIG | 1 | 1 | x | x | x | ETRIG1 Pin | | |

Table 7-33. eQADC_B Command FIFO 0 Trigger Sources

| eTSEL | cTSEL0_1 | | | | | eQADC_B Trigger Inputs |
|-------|----------|---|---|---|---------|-------------------------|
| | 0 | 0 | | | | |
| | 0 | 0 | 0 | 0 | 0 | Not Connected (default) |
| | | | 0 | 0 | 1 | RTI Trigger |
| | | | 0 | 1 | 0 | PIT0 Trigger |
| | | | 0 | 1 | 1 | PIT1 Trigger |
| | | | 1 | 0 | 0 | PIT2 Trigger |
| | | | 1 | 0 | 1 | PIT3 Trigger |
| | | | 1 | 1 | 0 | Reserved |
| | | | 1 | 1 | 1 | eTRIG1 pin |
| | | | 1 | 0 | x | Reserved |
| | | | 1 | 1 | 0 | eTPUA28 |
| | | | 1 | 1 | 0 | eTPUA29 |
| | | | 1 | 1 | 1 | eTPUA30 |
| | | | 1 | 1 | 1 | eTPUA31 |
| | | | 1 | 0 | 0 | eTPUB28 |
| | | | 1 | 0 | 0 | eTPUB29 |
| | | | 1 | 0 | 1 | eTPUB30 |
| | | | 1 | 0 | 1 | eTPUB31 |
| | | | 1 | 0 | 0 | Reserved |
| | | | 1 | 0 | 1 | Reversed |
| | | | 1 | 0 | 1 | Reserved |
| | | | 1 | 0 | 1 | Reserved |
| | | | 1 | 1 | 0 | eMIOS16 |
| | | | 1 | 1 | 0 | eMIOS17 |
| | | | 1 | 1 | 0 | eMIOS18 |
| | | | 1 | 1 | 0 | eMIOS19 |
| | | | 1 | 1 | 1 | eMIOS20 |
| | | | 1 | 1 | 1 | eMIOS21 |
| | | 1 | 1 | 1 | eMIOS22 | |
| | | 1 | 1 | 1 | eMIOS23 | |
| eTPU | 0 | 1 | | | | eTPUA30 |
| eMIOS | 1 | 0 | | | | eMIOS10 |
| eTRIG | 1 | 1 | | | | ETRIG0 Pin |

Table 7-34. eQADC_B Command FIFO 1 Trigger Sources

| eTSEL | cTSEL1_1 | | | | | eQADC_B Trigger Inputs | | |
|-------|----------|---|---|---|---------|-------------------------|---|--------------|
| | 0 | 0 | 0 | 0 | 0 | | | |
| eTSEL | 0 | 0 | 0 | 0 | 0 | Not Connected (default) | | |
| | | | 0 | 0 | 0 | 0 | 1 | RTI Trigger |
| | | | 0 | 0 | 0 | 1 | 0 | PIT0 Trigger |
| | | | 0 | 0 | 0 | 1 | 1 | PIT1 Trigger |
| | | | 0 | 0 | 1 | 0 | 0 | PIT2 Trigger |
| | | | 0 | 0 | 1 | 0 | 1 | PIT3 Trigger |
| | | | 0 | 0 | 1 | 1 | 0 | eTPUA7 |
| | | | 0 | 0 | 1 | 1 | 1 | eTRIG0 pin |
| | | | 0 | 1 | 0 | x | x | Reserved |
| | | | 0 | 1 | 1 | 0 | 0 | eTPUA28 |
| | | | 0 | 1 | 1 | 0 | 1 | eTPUA29 |
| | | | 0 | 1 | 1 | 1 | 0 | eTPUA30 |
| | | | 0 | 1 | 1 | 1 | 1 | eTPUA31 |
| | | | 1 | 0 | 0 | 0 | 0 | eTPUB28 |
| | | | 1 | 0 | 0 | 0 | 1 | eTPUB29 |
| | | | 1 | 0 | 0 | 1 | 0 | eTPUB30 |
| | | | 1 | 0 | 0 | 1 | 1 | eTPUB31 |
| | | | 1 | 0 | 1 | 0 | 0 | Reserved |
| | | | 1 | 0 | 1 | 0 | 1 | Reversed |
| | | | 1 | 0 | 1 | 1 | 0 | Reserved |
| | | | 1 | 0 | 1 | 1 | 1 | Reserved |
| | | | 1 | 1 | 0 | 0 | 0 | eMIOS16 |
| | | | 1 | 1 | 0 | 0 | 1 | eMIOS17 |
| | | | 1 | 1 | 0 | 1 | 0 | eMIOS18 |
| | | | 1 | 1 | 0 | 1 | 1 | eMIOS19 |
| | | | 1 | 1 | 1 | 0 | 0 | eMIOS20 |
| 1 | 1 | 1 | 0 | 1 | eMIOS21 | | | |
| 1 | 1 | 1 | 1 | 0 | eMIOS22 | | | |
| 1 | 1 | 1 | 1 | 1 | eMIOS23 | | | |
| eTPU | 0 | 1 | x | x | x | eTPUA31 | | |
| eMIOS | 1 | 0 | x | x | x | eMIOS11 | | |
| eTRIG | 1 | 1 | x | x | x | ETRIG1 Pin | | |

Table 7-35. eQADC_B Command FIFO 2 Trigger Sources

| eTSEL | cTSEL2_1 | | | | | eQADC_B Trigger Inputs | | |
|-------|----------|---|---|---|---------|-------------------------|---|--------------|
| | 0 | 0 | | | | | | |
| eTSEL | 0 | 0 | 0 | 0 | 0 | Not Connected (default) | | |
| | | | 0 | 0 | 0 | 0 | 1 | RTI Trigger |
| | | | 0 | 0 | 0 | 1 | 0 | PIT0 Trigger |
| | | | 0 | 0 | 0 | 1 | 1 | PIT1 Trigger |
| | | | 0 | 0 | 1 | 0 | 0 | PIT2 Trigger |
| | | | 0 | 0 | 1 | 0 | 1 | PIT3 Trigger |
| | | | 0 | 0 | 1 | 1 | 0 | eTPUA14 |
| | | | 0 | 0 | 1 | 1 | 1 | eTRIG1 pin |
| | | | 0 | 1 | 0 | x | x | Reserved |
| | | | 0 | 1 | 1 | 0 | 0 | eTPUA28 |
| | | | 0 | 1 | 1 | 0 | 1 | eTPUA29 |
| | | | 0 | 1 | 1 | 1 | 0 | eTPUA30 |
| | | | 0 | 1 | 1 | 1 | 1 | eTPUA31 |
| | | | 1 | 0 | 0 | 0 | 0 | eTPUB28 |
| | | | 1 | 0 | 0 | 0 | 1 | eTPUB29 |
| | | | 1 | 0 | 0 | 1 | 0 | eTPUB30 |
| | | | 1 | 0 | 0 | 1 | 1 | eTPUB31 |
| | | | 1 | 0 | 1 | 0 | 0 | Reserved |
| | | | 1 | 0 | 1 | 0 | 1 | Reversed |
| | | | 1 | 0 | 1 | 1 | 0 | Reserved |
| | | | 1 | 0 | 1 | 1 | 1 | Reserved |
| | | | 1 | 1 | 0 | 0 | 0 | eMIOS16 |
| | | | 1 | 1 | 0 | 0 | 1 | eMIOS17 |
| | | | 1 | 1 | 0 | 1 | 0 | eMIOS18 |
| | | | 1 | 1 | 0 | 1 | 1 | eMIOS19 |
| | | | 1 | 1 | 1 | 0 | 0 | eMIOS20 |
| | | | 1 | 1 | 1 | 0 | 1 | eMIOS21 |
| 1 | 1 | 1 | 1 | 0 | eMIOS22 | | | |
| 1 | 1 | 1 | 1 | 1 | eMIOS23 | | | |
| eTPU | 0 | 1 | x | x | x | eTPUA29 | | |
| eMIOS | 1 | 0 | x | x | x | eMIOS15 | | |
| eTRIG | 1 | 1 | x | x | x | ETRIG0 Pin | | |

Table 7-36. eQADC_B Command FIFO 3 Trigger Sources

| eTSEL | cTSEL3_1 | | | | | eQADC_B Trigger Inputs | |
|-------|----------|---|---|---|---|-------------------------|----------|
| | 0 | 0 | | | | | |
| eTSEL | 0 | 0 | 0 | 0 | 0 | Not Connected (default) | |
| | | | 0 | 0 | 1 | RTI Trigger | |
| | | | 0 | 1 | 0 | PIT0 Trigger | |
| | | | 0 | 1 | 1 | PIT1 Trigger | |
| | | | 1 | 0 | 0 | PIT2 Trigger | |
| | | | 1 | 0 | 1 | PIT3 Trigger | |
| | | | 1 | 1 | 0 | eTPUA22 | |
| | | | 1 | 1 | 1 | eTRIG0 pin | |
| | | 0 | 1 | 0 | x | x | Reserved |
| | | 0 | 1 | 1 | 0 | 0 | eTPUA28 |
| | | 0 | 1 | 1 | 0 | 1 | eTPUA29 |
| | | 0 | 1 | 1 | 1 | 0 | eTPUA30 |
| | | 0 | 1 | 1 | 1 | 1 | eTPUA31 |
| | | 1 | 0 | 0 | 0 | 0 | eTPUB28 |
| | | 1 | 0 | 0 | 0 | 1 | eTPUB29 |
| | | 1 | 0 | 0 | 1 | 0 | eTPUB30 |
| | | 1 | 0 | 0 | 1 | 1 | eTPUB31 |
| | | 1 | 0 | 1 | 0 | 0 | Reserved |
| | | 1 | 0 | 1 | 0 | 1 | Reversed |
| | | 1 | 0 | 1 | 1 | 0 | Reserved |
| | | 1 | 0 | 1 | 1 | 1 | Reserved |
| | | 1 | 1 | 0 | 0 | 0 | eMIOS16 |
| | | 1 | 1 | 0 | 0 | 1 | eMIOS17 |
| | | 1 | 1 | 0 | 1 | 0 | eMIOS18 |
| | | 1 | 1 | 0 | 1 | 1 | eMIOS19 |
| | | 1 | 1 | 1 | 0 | 0 | eMIOS20 |
| | | 1 | 1 | 1 | 0 | 1 | eMIOS21 |
| | 1 | 1 | 1 | 1 | 0 | eMIOS22 | |
| | 1 | 1 | 1 | 1 | 1 | eMIOS23 | |
| eTPU | 0 | 1 | | | | eTPUA28 | |
| eMIOS | 1 | 0 | | | | eMIOS14 | |
| eTRIG | 1 | 1 | | | | ETRIG1 Pin | |

Table 7-37. eQADC_B Command FIFO 4 Trigger Sources

| eTSEL | cTSEL4_1 | | | | | eQADC_B Trigger Inputs |
|-------|----------|---|---|---|---------|-------------------------|
| | 0 | 0 | | | | |
| eTSEL | 0 | 0 | 0 | 0 | 0 | Not Connected (default) |
| | | | 0 | 0 | 1 | RTI Trigger |
| | | | 0 | 1 | 0 | PIT0 Trigger |
| | | | 0 | 1 | 1 | PIT1 Trigger |
| | | | 1 | 0 | 0 | PIT2 Trigger |
| | | | 1 | 0 | 1 | PIT3 Trigger |
| | | | 1 | 1 | 0 | eTPUA30 |
| | | | 1 | 1 | 1 | eTRIG1 pin |
| | | | 1 | 0 | x | Reserved |
| | | | 1 | 1 | 0 | eTPUA28 |
| | | | 1 | 1 | 0 | eTPUA29 |
| | | | 1 | 1 | 1 | eTPUA30 |
| | | | 1 | 1 | 1 | eTPUA31 |
| | | | 1 | 0 | 0 | eTPUB28 |
| | | | 1 | 0 | 0 | eTPUB29 |
| | | | 1 | 0 | 1 | eTPUB30 |
| | | | 1 | 0 | 1 | eTPUB31 |
| | | | 1 | 0 | 1 | Reserved |
| | | | 1 | 0 | 1 | Reversed |
| | | | 1 | 0 | 1 | Reserved |
| | | | 1 | 0 | 1 | Reserved |
| | | | 1 | 1 | 0 | eMIOS16 |
| | | | 1 | 1 | 0 | eMIOS17 |
| | | | 1 | 1 | 0 | eMIOS18 |
| | | | 1 | 1 | 0 | eMIOS19 |
| | | | 1 | 1 | 1 | eMIOS20 |
| | | | 1 | 1 | 1 | eMIOS21 |
| | | 1 | 1 | 1 | eMIOS22 | |
| | | 1 | 1 | 1 | eMIOS23 | |
| eTPU | 0 | 1 | x | x | x | eTPUA27 |
| eMIOS | 1 | 0 | x | x | x | eMIOS13 |
| eTRIG | 1 | 1 | x | x | x | ETRIG0 Pin |

Table 7-38. eQADC_B Command FIFO 5 Trigger Sources

| eTSEL | cTSEL5_1 | | | | | eQADC_B Trigger Inputs |
|-------|----------|---|---|---|---------|-------------------------|
| | 0 | 0 | | | | |
| eTSEL | 0 | 0 | 0 | 0 | 0 | Not Connected (default) |
| | | | 0 | 0 | 1 | RTI Trigger |
| | | | 0 | 1 | 0 | PIT0 Trigger |
| | | | 0 | 1 | 1 | PIT1 Trigger |
| | | | 1 | 0 | 0 | PIT2 Trigger |
| | | | 1 | 0 | 1 | PIT3 Trigger |
| | | | 1 | 1 | 0 | Reserved |
| | | | 1 | 1 | 1 | eTRIG0 pin |
| | | | 1 | x | x | Reserved |
| | | | 1 | 0 | 0 | eTPUA28 |
| | | | 1 | 0 | 1 | eTPUA29 |
| | | | 1 | 1 | 0 | eTPUA30 |
| | | | 1 | 1 | 1 | eTPUA31 |
| | | | 1 | 0 | 0 | eTPUB28 |
| | | | 1 | 0 | 1 | eTPUB29 |
| | | | 1 | 0 | 0 | eTPUB30 |
| | | | 1 | 0 | 1 | eTPUB31 |
| | | | 1 | 0 | 0 | Reserved |
| | | | 1 | 0 | 1 | Reversed |
| | | | 1 | 0 | 1 | Reserved |
| | | | 1 | 0 | 1 | Reserved |
| | | | 1 | 1 | 0 | eMIOS16 |
| | | | 1 | 1 | 0 | eMIOS17 |
| | | | 1 | 1 | 0 | eMIOS18 |
| | | | 1 | 1 | 0 | eMIOS19 |
| | | | 1 | 1 | 1 | eMIOS20 |
| | | | 1 | 1 | 1 | eMIOS21 |
| | | 1 | 1 | 1 | eMIOS22 | |
| | | 1 | 1 | 1 | eMIOS23 | |
| eTPU | 0 | 1 | x | x | x | eTPUA26 |
| eMIOS | 1 | 0 | x | x | x | eMIOS12 |
| eTRIG | 1 | 1 | x | x | x | ETRIG1 Pin |

7.3.1.19 eTPU Input Select Register (SIU_ISEL 8)

The SIU_ISEL 8 register is used to multiplex the ETPU[24:29] inputs. These 6 ETPU channels can come from the output of the DSPI or corresponding pad. When SIU_ISEL8 is in its default state, the eTPU pins listed in [Figure 7-19](#) will not be enabled as input, irrespective of the SIU_PCR[PA] field (PCR138-143).

Address: SIU_BASE + 0x0920

Access: R/W

| | | | | | | | | | | | | | | | | |
|-------|----|----|----|------------|----|----|----|------------|----|----|----|------------|----|----|----|------------|
| | 0 | 1 | 2 | 3 | 4 | 5 | 6 | 7 | 8 | 9 | 10 | 11 | 12 | 13 | 14 | 15 |
| R | 0 | 0 | 0 | 0 | 0 | 0 | 0 | 0 | 0 | 0 | 0 | eTPU 29 | 0 | 0 | 0 | eTPU 28 |
| W | | | | | | | | | | | | | | | | |
| Reset | 0 | 0 | 0 | 0 | 0 | 0 | 0 | 0 | 0 | 0 | 0 | 0 | 0 | 0 | 0 | 0 |
| | 16 | 17 | 18 | 19 | 20 | 21 | 22 | 23 | 24 | 25 | 26 | 27 | 28 | 29 | 30 | 31 |
| R | 0 | 0 | 0 | eTPU 27 | 0 | 0 | 0 | eTPU 26 | 0 | 0 | 0 | eTPU 25 | 0 | 0 | 0 | eTPU 24 |
| W | | | | | | | | | | | | | | | | |
| Reset | 0 | 0 | 0 | 0 | 0 | 0 | 0 | 0 | 0 | 0 | 0 | 0 | 0 | 0 | 0 | 0 |

Figure 7-19. eTPU Input Select Register (SIU_ISEL8)

Table 7-39. SIU_ISEL8 Bit Field Descriptions

| Field | Description |
|--------------|--|
| 0–11 | Reserved |
| 11 eTPU29 | eTPU29 input select. Specifies the source of the eTPU29 channel input. 0 DSPI_B Serialized input 8 1 eTPU29 channel input pad |
| 12–14 | Reserved |
| 15 eTPU28 | eTPU28 input select. Specifies the source of the eTPU28 channel input. 0 DSPI_B Serialized input 9 1 eTPU28 channel input pad |
| 16–18 | Reserved |
| 19 eTPU27 | eTPU27 input select. Specifies the source of the eTPU27 channel input. 0 DSPI_B Serialized input 10 1 eTPU27 channel input pad |
| 20–22 | Reserved |
| 23 eTPU26 | eTPU26 input select. Specifies the source of the eTPU26 channel input. 0 DSPI_B Serialized input 11 1 eTPU26 channel input pad |
| 24–26 | Reserved |
| 27 eTPU25 | eTPU25 input select. Specifies the source of the eTPU25 channel input. 0 DSPI_B Serialized input 12 1 eTPU25 channel input pad |

Table 7-39. SIU_ISEL8 Bit Field Descriptions

| Field | Description |
|--------------|--|
| 28–30 | Reserved |
| 31 eTPU24 | eTPU24 input select. Specifies the source of the eTPU24 channel input. 0 DSPI_B Serialized input 13 1 eTPU24 channel input pad |

7.3.1.20 eQADC Advance Trigger Selection (SIU_ISEL9)

The eQADC's streaming mode requires a second trigger for Queue 0. The source for this trigger can come from ETPU, EMIOS or PIT channels. This mux select register selects the source of the Queue 0 trigger.

Address: SIU_BASE + 0x0924

Access: R/W

| | 0 | 1 | 2 | 3 | 4 | 5 | 6 | 7 | 8 | 9 | 10 | 11 | 12 | 13 | 14 | 15 |
|-------|---|---|---|---|---|---|---|---|---|---|----|----|----|----|----|----|
| R | 0 | 0 | 0 | 0 | 0 | 0 | 0 | 0 | 0 | 0 | 0 | 0 | 0 | 0 | 0 | 0 |
| W | | | | | | | | | | | | | | | | |
| Reset | 0 | 0 | 0 | 0 | 0 | 0 | 0 | 0 | 0 | 0 | 0 | 0 | 0 | 0 | 0 | 0 |

| | 16 | 17 | 18 | 19 | 20 | 21 | 22 | 23 | 24 | 25 | 26 | 27 | 28 | 29 | 30 | 31 |
|-------|----|----|----|----|----|----|----|----|----|----|----|---------|----|----|----|----|
| R | 0 | 0 | 0 | 0 | 0 | 0 | 0 | 0 | 0 | 0 | 0 | eTSEL0A | | | | |
| W | | | | | | | | | | | | | | | | |
| Reset | 0 | 0 | 0 | 0 | 0 | 0 | 0 | 0 | 0 | 0 | 0 | 0 | 0 | 0 | 0 | 0 |

Figure 7-20. eQADC Advance Trigger Selection (SIU_ISEL9)
Table 7-40. eTSEL0A Bit Field Descriptions

| eTSEL0A | | | | | eQADC Trigger Input |
|---------|---|---|---|---|---------------------|
| 0 | 0 | 0 | 0 | 0 | Reserved |
| 0 | 0 | 0 | 0 | 1 | RTI Trigger |
| 0 | 0 | 0 | 1 | 0 | PIT0 Trigger |
| 0 | 0 | 0 | 1 | 1 | PIT1 Trigger |
| 0 | 0 | 1 | 0 | 0 | PIT2 Trigger |
| 0 | 0 | 1 | 0 | 1 | PIT3 Trigger |
| 0 | 0 | 1 | 1 | 0 | Reserved |
| 0 | 0 | 1 | 1 | 1 | Reserved |
| 0 | 1 | 0 | 0 | 0 | eTPUA30 AND PIT0 |
| 0 | 1 | 0 | 0 | 1 | eTPUA30 AND PIT1 |
| 0 | 1 | 0 | 1 | 0 | Reserved |
| 0 | 1 | 0 | 1 | 1 | Reserved |
| 0 | 1 | 1 | 0 | 0 | eTPUA28 |
| 0 | 1 | 1 | 0 | 1 | eTPUA29 |

Table 7-40. eTSEL0A Bit Field Descriptions (continued)

| eTSEL0A | | | | | eQADC Trigger Input |
|---------|---|---|---|---|---------------------|
| 0 | 1 | 1 | 1 | 0 | eTPUA30 |
| 0 | 1 | 1 | 1 | 1 | eTPUA31 |
| 1 | 0 | 0 | 0 | 0 | Reserved |
| 1 | 0 | 0 | 0 | 1 | Reserved |
| 1 | 0 | 0 | 1 | 0 | Reserved |
| 1 | 0 | 0 | 1 | 1 | Reserved |
| 1 | 0 | 1 | 0 | 0 | eMIOS10 AND PIT2 |
| 1 | 0 | 1 | 0 | 1 | eMIOS10 AND PIT3 |
| 1 | 0 | 1 | 1 | 0 | Reserved |
| 1 | 0 | 1 | 1 | 1 | Reserved |
| 1 | 1 | 0 | 0 | 0 | Reserved |
| 1 | 1 | 0 | 0 | 1 | Reserved |
| 1 | 1 | 0 | 1 | 0 | Reserved |
| 1 | 1 | 0 | 1 | 1 | Reserved |
| 1 | 1 | 1 | 0 | 0 | Reserved |
| 1 | 1 | 1 | 0 | 1 | Reserved |
| 1 | 1 | 1 | 1 | 0 | Reserved |
| 1 | 1 | 1 | 1 | 1 | eMIOS23 |

7.3.1.21 Decimation Filter Register 1 (SIU_DECFIL1)

The SIU_DECFIL1 register contains four ZSEL_x and HSEL_x fields that route selected eTPU outputs to the ZIR (Zero/Integrate/Read) and Halt inputs for decimation filters A through D. See [Chapter 28, Decimation Filter](#), for more information on the ZIR and Halt operations in the decimation filter.

Address: SIU_BASE + 0x0928

Access: R/W

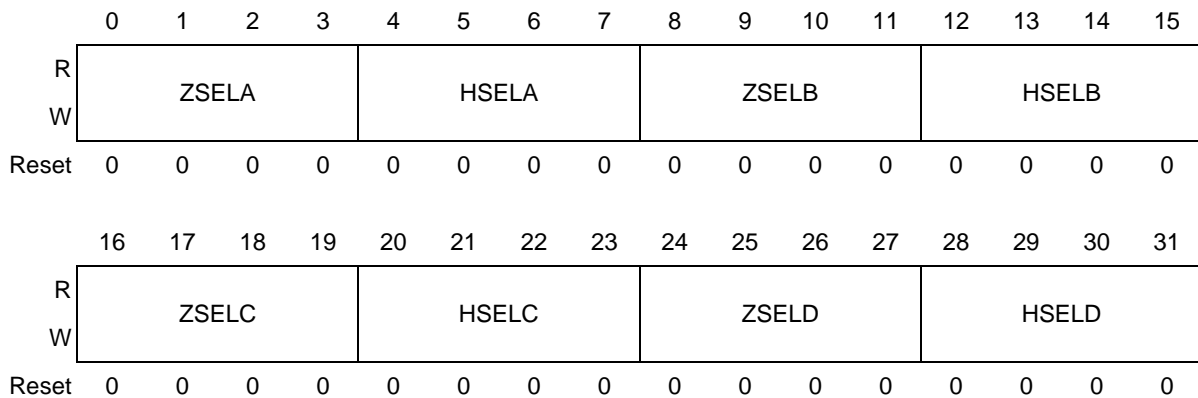

Table 7-41. SIU_DECFIL1 Bit Field Descriptions

| Field | Description |
|----------------|--|
| 0–3 ZSELA | ZIR Input Select for Decimation Filter A 0000 Unused 0001 eTPUA Channel 22 0010 eTPUA Channel 23 0011 eTPUA Channel 24 0100 eTPUA Channel 25 |
| 4–7 HSELA | Halt Input Select for Decimation Filter A 0000 Unused 0001 eTPUA Channel 22 0010 eTPUA Channel 23 0011 eTPUA Channel 24 0100 eTPUA Channel 25 |
| 8–11 ZSELB | ZIR Input Select for Decimation Filter B 0000 Unused 0001 eTPUA Channel 22 0010 eTPUA Channel 23 0011 eTPUA Channel 24 0100 eTPUA Channel 25 |
| 12–15 HSELB | Halt Input Select for Decimation Filter B 0000 Unused 0001 eTPUA Channel 22 0010 eTPUA Channel 23 0011 eTPUA Channel 24 0100 eTPUA Channel 25 |
| 16–19 ZSELC | ZIR Input Select for Decimation Filter C 0000 Unused 0001 eTPUB Channel 22 0010 eTPUB Channel 23 0011 eTPUB Channel 24 0100 eTPUB Channel 25 |
| 20–23 HSELC | Halt Input Select for Decimation Filter C 0000 Unused 0001 eTPUB Channel 22 0010 eTPUB Channel 23 0011 eTPUB Channel 24 0100 eTPUB Channel 25 |
| 24–27 ZSELD | ZIR Input Select for Decimation Filter D 0000 Unused 0001 eTPUB Channel 22 0010 eTPUB Channel 23 0011 eTPUB Channel 24 0100 eTPUB Channel 25 |
| 28–31 HSELD | Halt Input Select for Decimation Filter D 0000 Unused 0001 eTPUB Channel 22 0010 eTPUB Channel 23 0011 eTPUB Channel 24 0100 eTPUB Channel 25 |

7.3.1.22 Decimation Filter Register 2 (SIU_DECFIL2)

The SIU_DECFIL2 register contains four ZSEL_x and HSEL_x fields that route selected eTPU outputs to the ZIR (Zero/Integrate/Read) and Halt inputs for decimation filters E through H. See [Chapter 28, Decimation Filter](#), for more information on the ZIR and Halt operations in the decimation filter.

Address: SIU_BASE + 0x092C

Access: R/W

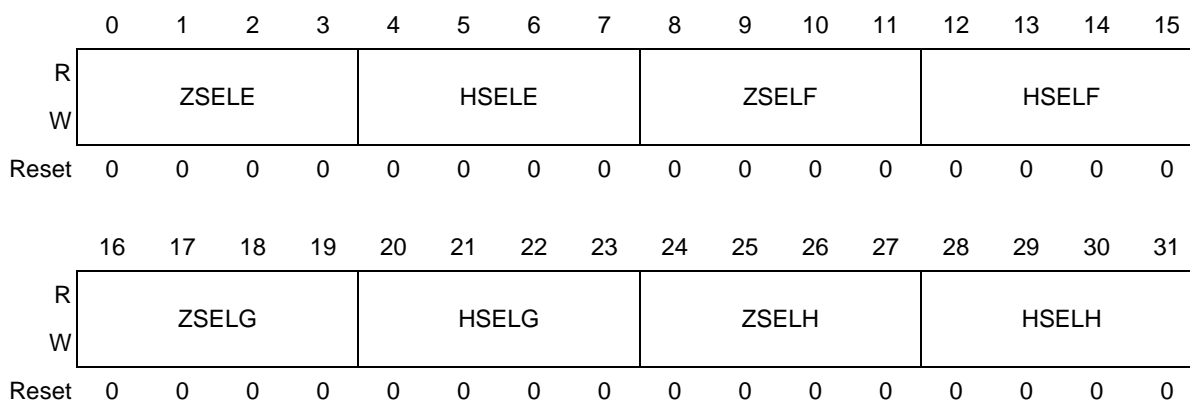

Table 7-42. SIU_DECFIL2 Bit Field Descriptions

| Field | Description |
|----------------|--|
| 0–3 ZSELE | ZIR Input Select for Decimation Filter E 0000 Unused 0001 eTPUA Channel 18 0010 eTPUA Channel 19 0011 eTPUA Channel 20 0100 eTPUA Channel 21 |
| 4–7 HSELE | Halt Input Select for Decimation Filter E 0000 Unused 0001 eTPUA Channel 18 0010 eTPUA Channel 19 0011 eTPUA Channel 20 0100 eTPUA Channel 21 |
| 8–11 ZSELF | ZIR Input Select for Decimation Filter F 0000 Unused 0001 eTPUA Channel 18 0010 eTPUA Channel 19 0011 eTPUA Channel 20 0100 eTPUA Channel 21 |
| 12–15 HSELF | Halt Input Select for Decimation Filter F 0000 Unused 0001 eTPUA Channel 18 0010 eTPUA Channel 19 0011 eTPUA Channel 20 0100 eTPUA Channel 21 |

Table 7-42. SIU_DECFIL2 Bit Field Descriptions (continued)

| Field | Description |
|----------------|--|
| 16–19 ZSELG | ZIR Input Select for Decimation Filter G 0000 Unused 0001 eTPUB Channel 18 0010 eTPUB Channel 19 0011 eTPUB Channel 20 0100 eTPUB Channel 21 |
| 20–23 HSELG | Halt Input Select for Decimation Filter G 0000 Unused 0001 eTPUB Channel 18 0010 eTPUB Channel 19 0011 eTPUB Channel 20 0100 eTPUB Channel 21 |
| 24–27 ZSELH | ZIR Input Select for Decimation Filter H 0000 Unused 0001 eTPUB Channel 18 0010 eTPUB Channel 19 0011 eTPUB Channel 20 0100 eTPUB Channel 21 |
| 28–31 HSELH | Halt Input Select for Decimation Filter H 0000 Unused 0001 eTPUB Channel 18 0010 eTPUB Channel 19 0011 eTPUB Channel 20 0100 eTPUB Channel 21 |

7.3.1.23 Chip Configuration Register (SIU_CCR)

The SIU_CCR controls the chip configuration for enabling and disabling Nexus on the external bus interface.

Address: SIU_BASE + 0x0980

Access: R/W

| | | | | | | | | | | | | | | | | |
|-------|----|----|----|----|----|----|----|----|----|----|----|----|----|----|-------|----------------|
| | 0 | 1 | 2 | 3 | 4 | 5 | 6 | 7 | 8 | 9 | 10 | 11 | 12 | 13 | 14 | 15 |
| R | 0 | 0 | 0 | 0 | 0 | 0 | 0 | 0 | 0 | 0 | 0 | 0 | 0 | 0 | MATCH | DISNEX |
| W | | | | | | | | | | | | | | | | |
| Reset | 0 | 0 | 0 | 0 | 0 | 0 | 0 | 0 | 0 | 0 | 0 | 0 | 0 | 0 | 0 | X ¹ |
| | 16 | 17 | 18 | 19 | 20 | 21 | 22 | 23 | 24 | 25 | 26 | 27 | 28 | 29 | 30 | 31 |
| R | 0 | 0 | 0 | 0 | 0 | 0 | 0 | 0 | 0 | 0 | 0 | 0 | 0 | 0 | 0 | TEST |
| W | | | | | | | | | | | | | | | | |
| Reset | 0 | 0 | 0 | 0 | 0 | 0 | 0 | 0 | 0 | 0 | 0 | 0 | 0 | 0 | 0 | 0 |

¹ When system $\overline{\text{RESET}}$ negates, the value in this bit depends on the censorship control word and the boot configuration bits.

Figure 7-21. Chip Configuration Register (SIU_CCR)

The following table describes the chip configuration fields:

Table 7-43. SIU_CCR Bit Field Descriptions

| Field | Description |
|--------------|---|
| 0–13 | Reserved |
| 14 MATCH | Compare register match. Holds the value of the match input signal to the SIU. The match input is asserted if the values in SIU_CBRH and SIU_CBRL are the same as the public password stored in flash, 0xFEED_FACE_CAFE_BEEF. The MATCH bit is reset by the internal reset condition. 0 Match input signal is negated 1 Match input signal is asserted |
| 15 DISNEX | Disable Nexus. Holds the value of the Nexus disable input signal to the SIU. When system reset negates, the value in this bit depends on the censorship control word and the boot configuration bits. 0 Nexus disable input signal is negated. 1 Nexus disable input signal is asserted. |
| 16–30 | Reserved |
| 31 TEST | Test mode enable. Allows reads or writes to undocumented registers used only for production tests. Since these production test registers are undocumented, estimating the impact of errant accesses to them is impossible. Do not change this bit from its negated state at reset. 0 Undocumented production test registers cannot be read or written. 1 Undocumented production test registers can be read or written. |

7.3.1.24 External Clock Control Register (SIU_ECCR)

The SIU_ECCR controls the timing relationship between the system clock and the external clocks ENGCLK and CLKOUT. All bits and fields in the SIU_ECCR are read/write and are reset by the internal reset condition.

Address: SIU_BASE + 0x0984

Access: R/W

| | | | | | | | | | | | | | | | | |
|-------|--------|----|----|----|----|----|----|------|----|----|----|------|----|------|----|----|
| | 0 | 1 | 2 | 3 | 4 | 5 | 6 | 7 | 8 | 9 | 10 | 11 | 12 | 13 | 14 | 15 |
| R | 0 | 0 | 0 | 0 | 0 | 0 | 0 | 0 | 0 | 0 | 0 | 0 | 0 | 0 | 0 | 0 |
| W | | | | | | | | | | | | | | | | |
| Reset | 0 | 0 | 0 | 0 | 0 | 0 | 0 | 0 | 0 | 0 | 0 | 0 | 0 | 0 | 0 | 0 |
| | 16 | 17 | 18 | 19 | 20 | 21 | 22 | 23 | 24 | 25 | 26 | 27 | 28 | 29 | 30 | 31 |
| R | ENGDIV | | | | | | | ECSS | 0 | 0 | 0 | EBTS | 0 | EBDF | | |
| W | | | | | | | | | | | | | | | | |
| Reset | 0 | 0 | 0 | 1 | 0 | 0 | 0 | 0 | 0 | 0 | 0 | 0 | 0 | 0 | 0 | 1 |

Figure 7-22. External Clock Control Register (SIU_ECCR)

The following table describes the external clock control fields:

Table 7-44. SIU_ECCR Bit Field Descriptions

| Field | Description |
|-----------------|---|
| 0–15 | Reserved |
| 16–23 ENGDIV | Engineering clock division factor. Specifies the frequency ratio between f_{periph} (also referred to as f_{platf} on this device) and ENGCLK. The ENGCLK frequency is divided from f_{platf} according to the following equation: $\text{Engineering clock frequency} = \frac{f_{\text{periph}}}{\text{ENGDIV} \times 2}$ The maximum ENGCLK frequency is 66 MHz (132 MHz ÷ 2) Note: Setting ENGDIV to 0 makes the ENGCLK frequency equal to the f_{periph} . |
| 24 ECSS | Engineering clock (ENGCLK) source select. 0 The system clock is the source of the ENGCLK. 1 The external clock (the EXTAL frequency of the oscillator) is the source of the ENGCLK. |
| 25–27 | Reserved |
| 28 EBTS | External bus tap select. Changes the phase relationship between the system clock and CLKOUT. Changing the phase relationship so that CLKOUT is advanced in relation to the system clock increases the output hold time of the external bus signals to a non-zero value. It also increases the output delay times, increases the input hold times to non-zero values, and decreases the input setup times. Refer to the <i>Electrical Specifications</i> for how the EBTS bit affects the external bus timing. 0 External bus signals have zero output hold times. 1 External bus signals have non-zero output hold times. Note: Do not change EBTS while an external bus transaction is in process. |

Table 7-44. SIU_ECCR Bit Field Descriptions

| Field | Description |
|---------------|---|
| 29 | Reserved |
| 30–31 EBDF | <p>External bus division factor. Specifies the frequency ratio between the system clock and the external clock, CLKOUT. Do not change EBDF during an external bus access or while an access is pending. The CLKOUT frequency is divided from the system clock frequency according to the descriptions below. When operating in full mode (1:1), set the divider to 0b01 (divide-by-2).</p> <p>00 Divide by 1 01 Divide by 2 10 Divide by 3 11 Divide by 4</p> |

7.3.1.25 Compare B Register High (SIU_CBRH)

The SIU_CBRH holds the 32-bit value that is compared against the public password in flash (0xFEED_FACE_CAFE_BEEF). The CMPBH field is read/write and is reset by the internal reset condition.

Address: SIU_BASE + 0x0990

Access: R/W

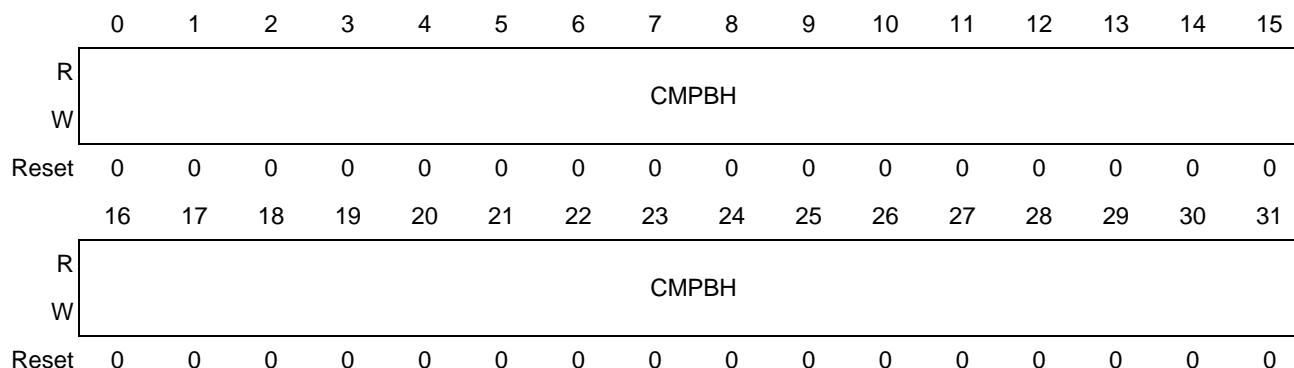

Figure 7-23. Compare B Register High (SIU_CBRH)

7.3.1.26 Compare B Register Low (SIU_CBRL)

The SIU_CBRL holds the 32-bit value that is compared against the public password in flash (0xFEED_FACE_CAFE_BEEF). The CMPBL field is read/write and is reset by the internal reset condition.

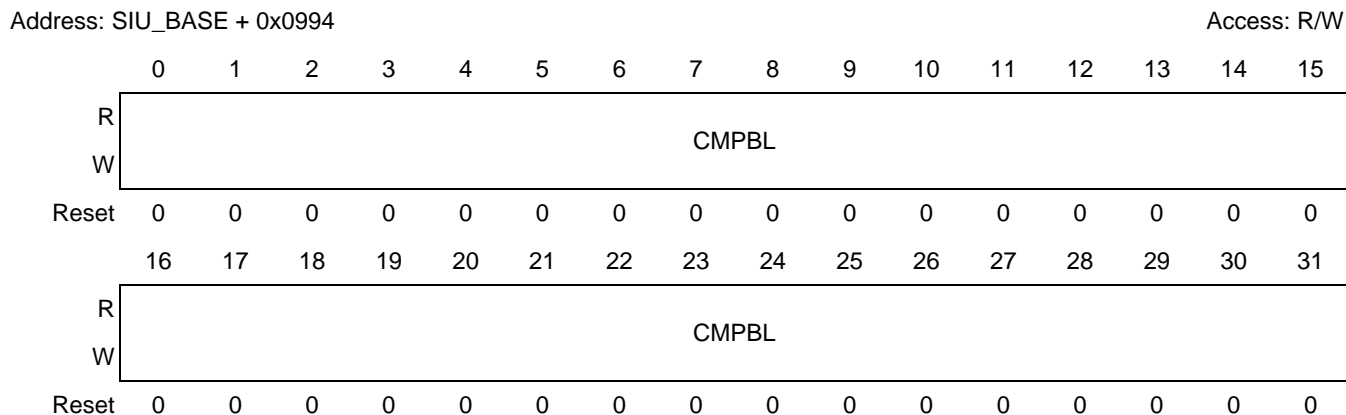

Figure 7-24. Compare B Register Low (SIU_CBRL)

7.3.1.27 System Clock Register (SIU_SYSDIV)

The SIU_SYSDIV field is read/write and is reset by the internal reset condition.

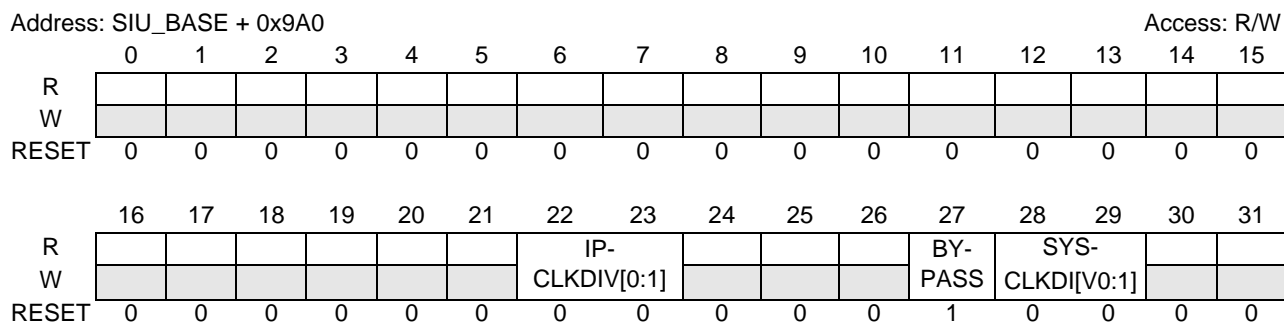

Figure 7-25. System Clock Register (SIU_SYSDIV)

Table 7-45. SIU_SYSDIV Bit Field Descriptions

| Field | Description |
|-------------------|---|
| 0-21 | Reserved |
| 22–23 IPCLKDIV | IP Clock Divider. The IPCLKDIV bits select the divider value for the platform, peripheral and eTPU clocks with respect to the system clock. 00 CPU frequency is doubled (Max 264Mhz). Platform, peripheral and eTPU clocks are 1/2 of CPU frequency 01 CPU and eTPU frequency is doubled (Max 200Mhz). Platform and peripheral clocks are 1/2 of CPU frequency 10 Reserved 11 CPU, eTPU, platform, and peripheral's clocks all run at same speed (Max 132Mhz) Note: Refer to the <i>PXR40 Microcontroller Data Sheet</i> for the latest frequency specifications. |

Table 7-45. SIU_SYSDIV Bit Field Descriptions

| Field | Description |
|--------------------|---|
| 24–26 | Reserved |
| 27 BYPASS | Bypass bit. 0 system clock divider is not bypassed 1 system clock divider is bypassed |
| 28–29 SYSCLKDIV | System Clock Divider. The SYSCLKDIV bits select the divider value for the system clock. Note that the SYSCLKDIV divider is required in addition to the RFD to allow the other source for the system clock (OSC) to be divided down to slowest frequencies to improve power. The output of the clock divider is nominally a 50% duty cycle. 00 Divide by 2 01 Divide by 4 10 Divide by 8 11 Divide by 16 |
| 30–31 | Reserved |

7.3.1.28 Halt Register (SIU_HLT)

The SIU_HLT register is used to disable the clocks to various modules. Each bit will drive a separate stop output of the SIU. These outputs will be connected as shown in [Table 7-46](#).

NOTE

Some peripherals have an MDIS (module disable) bit in the module control register that can be set to disable the module clock, reducing power consumption. In most cases the peripheral registers are still readable and writeable. However, using the SIU_HLT register also disables the read/write functions on the disabled peripheral's registers for additional power saving.

See [Section Chapter 20, Periodic Interrupt Timer \(PIT_RTI\)](#), for more information on how to use the SIU_HLT and SIU_HLTACK registers.

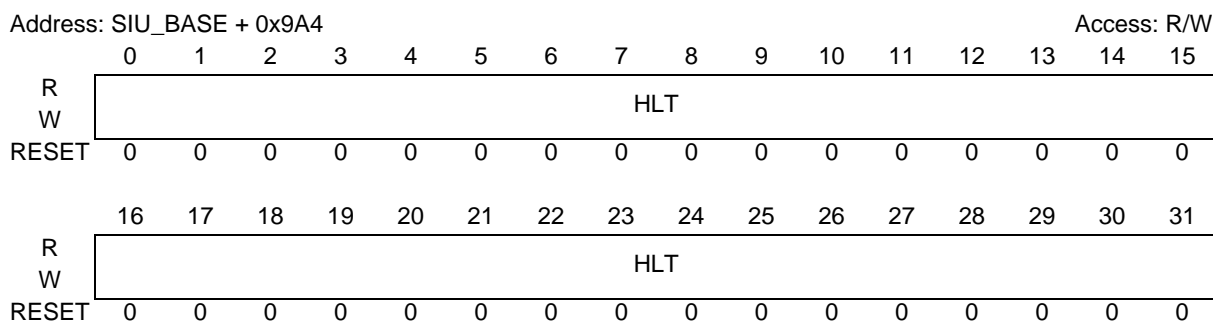

Figure 7-26. Halt Register (SIU_HLT)

Table 7-46. SIU_HLT Register Field Descriptions

| Field | Description |
|-------------|--|
| 0-31 HLT | Halt Selects The HLT bits halt specific modules. Each bit corresponds to a separate module as mapped below: 0 CPU and platform ¹ 1 rsvd 2 rsvd 3 rsvd 4 rsvd 5 eTPU_A and eTPU_B 6 NPC 7 EBI 8 eQADCs: eQADC_A and eQADC_B 9 rsvd 10 eMIOS_A 11 DECFILTs (decimation filters) 12 rsvd 13 PIT 14 rsvd 15 rsvd 16 FlexCAN_D 17 FlexCAN_C 18 FlexCAN_B 19 FlexCAN_A 20 DSPI_D 21 DSPI_C 22 DSPI_B 23 DSPI_A 24 rsvd 25 rsvd 26 rsvd 27 rsvd 28 rsvd 29 eSCI_C 30 eSCI_B 31 eSCI_A |

¹ Stops all CPU clocks; stops the platform, excluding interrupt controller and watchdogs. Note: these are only halted when the CPU executes a wait instruction to request the halt.

7.3.1.29 Halt Acknowledge Register (SIU_HLTACK)

The SIU_HLTACK bits indicate that the module requested to halt via the HLT bit has completed the halt process and has entered a halted state with the module clocks disabled. The HLTACK bits are read-only and writes have no effect, it is reset by the internal reset condition. The input signals from each module will be connected as shown in [Table 7-47., HALT Acknowledge Register Field Descriptions.](#)

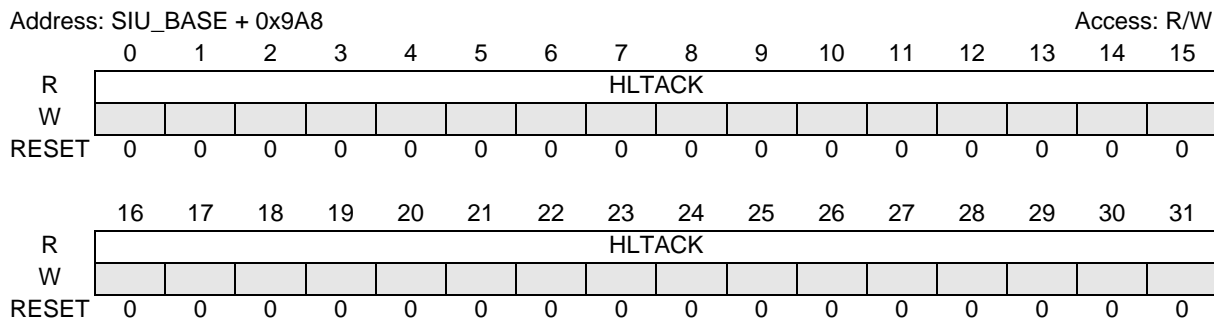

Figure 7-27. Halt Acknowledge Register (SIU_HLTACK)

Table 7-47. HALT Acknowledge Register Field Descriptions

| Field | Description |
|----------------|--|
| 0-31 HLTACK | Halt Acknowledge The HLTACK bits acknowledge halt for specific modules. Each bit corresponds to a separate module as mapped below: 0 CPU and platform ¹ 1 rsvd 2 rsvd 3 rsvd 4 rsvd 5 eTPU_A, eTPU_B 6 NPC 7 EBI 8 eQADCs: eQADC_A and eQADC_B 9 rsvd 10 eMIOS_A 11 DECFILTs (decimation filters) 12 rsvd 13 PIT 14 rsvd 15 rsvd 16 FlexCAN_D 17 FlexCAN_C 18 FlexCAN_B 19 FlexCAN_A 20 DSPI_D 21 DSPI_C 22 DSPI_B 23 DSPI_A 24 rsvd 25 rsvd 26 rsvd 27 rsvd 28 rsvd 29 eSCI_C 30 eSCI_B 31 eSCI_A |

¹ Stops all CPU clocks, stops the platform, excluding interrupt controller and watchdogs.

7.3.1.30 Parallel GPIO Pin Data Output Register (SIU_PGPDO0 - SIU_PGPDO15)

The PGPDO_x registers are written to by software to drive data out on the external GPIO pin. These registers access the same GPIO pins accessed by SIU_GPDO0–SIU_GPDO511 bit registers. The SIU_GPDO registers should map directly to these registers. For example, SIU_PGPDO0 bit 31 is SIU_GPDO31 bit 7, SIU_PGPDO0 bit 30 is SIU_GPDO30 bit 7,...., SIU_PGPDO7 bit 0 is SIU_GPDO224 bit 7. [Table 7-48](#) is a lookup table correlating the SIU_GPDO_x and SIU_PGPDO_n registers.

Table 7-48. Correlation between SIU_GPDO_x and SIU_PGPDO_n

| PGPDO _n | PGPDO _n bit number | | | | | | | | | | | | | | | | | | | | | | | | | | | | | | | |
|--------------------|-------------------------------|-----|-----|-----|-----|-----|-----|-----|-----|-----|-----|-----|-----|-----|-----|-----|-----|-----|-----|-----|-----|-----|-----|-----|-----|-----|-----|-----|-----|-----|-----|-----|
| | 0 | 1 | 2 | 3 | 4 | 5 | 6 | 7 | 8 | 9 | 10 | 11 | 12 | 13 | 14 | 15 | 16 | 17 | 18 | 19 | 20 | 21 | 22 | 23 | 24 | 25 | 26 | 27 | 28 | 29 | 30 | 31 |
| 0 | 0 | 1 | 2 | 3 | 4 | 5 | 6 | 7 | 8 | 9 | 10 | 11 | 12 | 13 | 14 | 15 | 16 | 17 | 18 | 19 | 20 | 21 | 22 | 23 | 24 | 25 | 26 | 27 | 28 | 29 | 30 | 31 |
| 1 | 32 | 33 | 34 | 35 | 36 | 37 | 38 | 39 | 40 | 41 | 42 | 43 | 44 | 45 | 46 | 47 | 48 | 49 | 50 | 51 | 52 | 53 | 54 | 55 | 56 | 57 | 58 | 59 | 60 | 61 | 62 | 63 |
| 2 | 64 | 65 | 66 | 67 | 68 | 69 | 70 | 71 | 72 | 73 | 74 | 75 | 76 | 77 | 78 | 79 | 80 | 81 | 82 | 83 | 84 | 85 | 86 | 87 | 88 | 89 | 90 | 91 | 92 | 93 | 94 | 95 |
| 3 | 96 | 97 | 98 | 99 | 100 | 101 | 102 | 103 | 104 | 105 | 106 | 107 | 108 | 109 | 110 | 111 | 112 | 113 | 114 | 115 | 116 | 117 | 118 | 119 | 120 | 121 | 122 | 123 | 124 | 125 | 126 | 127 |
| 4 | 128 | 129 | 130 | 131 | 132 | 133 | 134 | 135 | 136 | 137 | 138 | 139 | 140 | 141 | 142 | 143 | 144 | 145 | 146 | 147 | 148 | 149 | 150 | 151 | 152 | 153 | 154 | 155 | 156 | 157 | 158 | 159 |
| 5 | 160 | 161 | 162 | 163 | 164 | 165 | 166 | 167 | 168 | 169 | 170 | 171 | 172 | 173 | 174 | 175 | 176 | 177 | 178 | 179 | 180 | 181 | 182 | 183 | 184 | 185 | 186 | 187 | 188 | 189 | 190 | 191 |
| 6 | 192 | 193 | 194 | 195 | 196 | 197 | 198 | 199 | 200 | 201 | 202 | 203 | 204 | 205 | 206 | 207 | 208 | 209 | 210 | 211 | 212 | 213 | 214 | 215 | 216 | 217 | 218 | 219 | 220 | 221 | 222 | 223 |
| 7 | 224 | 225 | 226 | 227 | 228 | 229 | 230 | 231 | 232 | 233 | 234 | 235 | 236 | 237 | 238 | 239 | 240 | 241 | 242 | 243 | 244 | 245 | 246 | 247 | 248 | 249 | 250 | 251 | 252 | 253 | 254 | 255 |
| 8 | 256 | 257 | 258 | 259 | 260 | 261 | 262 | 263 | 264 | 265 | 266 | 267 | 268 | 269 | 270 | 271 | 272 | 273 | 274 | 275 | 276 | 277 | 278 | 279 | 280 | 281 | 282 | 283 | 284 | 285 | 286 | 287 |
| 9 | 288 | 289 | 290 | 291 | 292 | 293 | 294 | 295 | 296 | 297 | 298 | 299 | 300 | 301 | 302 | 303 | 304 | 305 | 306 | 307 | 308 | 309 | 310 | 311 | 312 | 313 | 314 | 315 | 316 | 317 | 318 | 319 |
| 10 | 320 | 321 | 322 | 323 | 324 | 325 | 326 | 327 | 328 | 329 | 330 | 331 | 332 | 333 | 334 | 335 | 336 | 337 | 338 | 339 | 340 | 341 | 342 | 343 | 344 | 345 | 346 | 347 | 348 | 349 | 350 | 351 |
| 11 | 352 | 353 | 354 | 355 | 356 | 357 | 358 | 359 | 360 | 361 | 362 | 363 | 364 | 365 | 366 | 367 | 368 | 369 | 370 | 371 | 372 | 373 | 374 | 375 | 376 | 377 | 378 | 379 | 380 | 381 | 382 | 383 |
| 12 | 384 | 385 | 386 | 387 | 388 | 389 | 390 | 391 | 392 | 393 | 394 | 395 | 396 | 397 | 398 | 399 | 400 | 401 | 402 | 403 | 404 | 405 | 406 | 407 | 408 | 409 | 410 | 411 | 412 | 413 | 414 | 415 |
| 13 | 416 | 417 | 418 | 419 | 420 | 421 | 422 | 423 | 424 | 425 | 426 | 427 | 428 | 429 | 430 | 431 | 432 | 433 | 434 | 435 | 436 | 437 | 438 | 439 | 440 | 441 | 442 | 443 | 444 | 445 | 446 | 447 |
| 14 | 448 | 449 | 450 | 451 | 452 | 453 | 454 | 455 | 456 | 457 | 458 | 459 | 460 | 461 | 462 | 463 | 464 | 465 | 466 | 467 | 468 | 469 | 470 | 471 | 472 | 473 | 474 | 475 | 476 | 477 | 478 | 479 |
| 15 | 480 | 481 | 482 | 483 | 484 | 485 | 486 | 487 | 488 | 489 | 490 | 491 | 492 | 493 | 494 | 495 | 496 | 497 | 498 | 499 | 500 | 501 | 502 | 503 | 504 | 505 | 506 | 507 | 508 | 509 | 510 | 511 |

The parallel GPIO read/write should be decode the logical addresses to the same physical address of the normal GPIO. This way both GPDO and corresponding PGPDO registers will be updated by a single write to a either register.

SIU_BASE + 0xC00 - SIU_BASE + 0xC3C (16)

| | | | | | | | | | | | | | | | | |
|--------|-------|-------|-------|-------|-------|-------|-------|-------|-------|-------|-------|-------|-------|-------|-------|-------|
| | 0 | 1 | 2 | 3 | 4 | 5 | 6 | 7 | 8 | 9 | 10 | 11 | 12 | 13 | 14 | 15 |
| R | PGPDO | PGPDO | PGPDO | PGPDO | PGPDO | PGPDO | PGPDO | PGPDO | PGPDO | PGPDO | PGPDO | PGPDO | PGPDO | PGPDO | PGPDO | PGPDO |
| W | 0 | 1 | 2 | 3 | 4 | 5 | 6 | 7 | 8 | 9 | 10 | 11 | 12 | 13 | 14 | 15 |
| RESET: | 0 | 0 | 0 | 0 | 0 | 0 | 0 | 0 | 0 | 0 | 0 | 0 | 0 | 0 | 0 | 0 |

| | | | | | | | | | | | | | | | | |
|--------|-------|-------|-------|-------|-------|-------|-------|-------|-------|-------|-------|-------|-------|-------|-------|-------|
| | 16 | 17 | 18 | 19 | 20 | 21 | 22 | 23 | 24 | 25 | 26 | 27 | 28 | 29 | 30 | 31 |
| R | PGPDO | PGPDO | PGPDO | PGPDO | PGPDO | PGPDO | PGPDO | PGPDO | PGPDO | PGPDO | PGPDO | PGPDO | PGPDO | PGPDO | PGPDO | PGPDO |
| W | 16 | 17 | 18 | 19 | 20 | 21 | 22 | 23 | 24 | 25 | 26 | 27 | 28 | 29 | 30 | 31 |
| RESET: | 0 | 0 | 0 | 0 | 0 | 0 | 0 | 0 | 0 | 0 | 0 | 0 | 0 | 0 | 0 | 0 |

Figure 7-28. Parallel GPIO Pin Data Output Register (SIU_PGPDO0 - SIU_PGPDO15)

Table 7-49. SIU_PGPDO0 - SIU_PGPDO15 Field Descriptions

| Field | Description |
|----------------|---|
| 0–31 PGPDOx | Pin Data Out. Stores the data to be driven out on the external GPIO pin controlled by this register. 0 Logic low value is driven on the data out signal for the corresponding GPIO pin when the pin is configured as an output. 1 Logic high value is driven on the data out signal for the corresponding GPIO pin when the pin is configured as an output. |

7.3.1.31 Parallel GPIO Pin Data Input Register (SIU_PGPDIO - SIU_PGPDIO15)

The GPDIO registers are read-only registers that allow reading of the input state of an external GPIO pin. These registers access the same GPIO pins accessed by SIU_GPDIO - SIU_GPDIO15 bit registers. The SIU_GPDIO registers should map directly to these registers. See [Section 7.3.1.30, Parallel GPIO Pin Data Output Register \(SIU_PGPDO0 - SIU_PGPDO15\)](#), for a lookup table and examples.

The GPIO read/write should decode logical addresses to the same physical address of the normal GPIO. This way both the GPDIO and corresponding PGPDIO register should be updated on a pin state change when the IBE is asserted in the corresponding PCR.

SIU_BASE + 0xC40 - SIU_BASE + 0xC7C (16)

| | | | | | | | | | | | | | | | | |
|--------|-------|-------|-------|-------|-------|-------|-------|-------|-------|-------|-------|-------|-------|-------|-------|-------|
| | 0 | 1 | 2 | 3 | 4 | 5 | 6 | 7 | 8 | 9 | 10 | 11 | 12 | 13 | 14 | 15 |
| R | PGPDI | PGPDI | PGPDI | PGPDI | PGPDI | PGPDI | PGPDI | PGPDI | PGPDI | PGPDI | PGPDI | PGPDI | PGPDI | PGPDI | PGPDI | PGPDI |
| W | | | | | | | | | | | | | | | | |
| RESET: | 0 | 0 | 0 | 0 | 0 | 0 | 0 | 0 | 0 | 0 | 0 | 0 | 0 | 0 | 0 | 0 |

| | | | | | | | | | | | | | | | | |
|--------|-------|-------|-------|-------|-------|-------|-------|-------|-------|-------|-------|-------|-------|-------|-------|-------|
| | 16 | 17 | 18 | 19 | 20 | 21 | 22 | 23 | 24 | 25 | 26 | 27 | 28 | 29 | 30 | 31 |
| R | PGPDI | PGPDI | PGPDI | PGPDI | PGPDI | PGPDI | PGPDI | PGPDI | PGPDI | PGPDI | PGPDI | PGPDI | PGPDI | PGPDI | PGPDI | PGPDI |
| W | 16 | 17 | 18 | 19 | 20 | 21 | 22 | 23 | 24 | 25 | 26 | 27 | 28 | 29 | 30 | 31 |
| RESET: | 0 | 0 | 0 | 0 | 0 | 0 | 0 | 0 | 0 | 0 | 0 | 0 | 0 | 0 | 0 | 0 |

Figure 7-29. Parallel GPIO Pin Data Input Register (SIU_PGPDIO - SIU_PGPDIO15)

Table 7-50. SIU_PGPDIO - SIU_PGPD15 - SIU_PGPDO15 Field Descriptions

| Field | Description |
|----------------|--|
| 0–31 PGPD1x | Pin Data In. Stores the value of the pad-interface signals (data in) corresponding to the external GPIO pin associated with the register. 0 The value of the pad-interface signals (data in) for the corresponding GPIO pin is logic low. 1 The value of the pad-interface signals (data in) for the corresponding GPIO pin is logic high. |

7.3.1.32 Masked Parallel GPIO Pin Data Output Register (SIU_MPGPDO0 - SIU_MPGPDO31)

The MPGPD0x registers are written to by software to drive data out on the external GPIO pin (they are write-only registers and reading them will return 0; reading must be done by accessing the corresponding SIU_GPDO register). These registers access the same GPIO pins accessed by SIU_GPDO0–SIU_GPDO511 bit registers. The most significant 16 bits in the SIU_MPGPDO registers should map directly to these registers. For example, SIU_MPGPDO0 bit 31 is SIU_GPDO15 bit 7, SIU_MPGPDO0 bit 30 is SIU_GPDO17 bit 7, ..., SIU_MPGPD15 bit 16 is SIU_GPDO240 bit 7. The least significant sixteen bits are the corresponding values to be written at GPIO pins defined by MASK field. The masked parallel GPIO read/write should be decode the logical addresses to the same physical address of the normal GPIO.

SIU_BASE + 0xC80 - SIU_BASE + 0xCFC (32)

| | | | | | | | | | | | | | | | | |
|--------|------|------|------|------|------|------|------|------|------|------|------|------|------|------|------|------|
| | 0 | 1 | 2 | 3 | 4 | 5 | 6 | 7 | 8 | 9 | 10 | 11 | 12 | 13 | 14 | 15 |
| R | | | | | | | | | | | | | | | | |
| W | MASK | MASK | MASK | MASK | MASK | MASK | MASK | MASK | MASK | MASK | MASK | MASK | MASK | MASK | MASK | MASK |
| RESET: | 0 | 0 | 0 | 0 | 0 | 0 | 0 | 0 | 0 | 0 | 0 | 0 | 0 | 0 | 0 | 0 |
| | 16 | 17 | 18 | 19 | 20 | 21 | 22 | 23 | 24 | 25 | 26 | 27 | 28 | 29 | 30 | 31 |
| R | | | | | | | | | | | | | | | | |
| W | DATA | DATA | DATA | DATA | DATA | DATA | DATA | DATA | DATA | DATA | DATA | DATA | DATA | DATA | DATA | DATA |
| RESET: | 0 | 0 | 0 | 0 | 0 | 0 | 0 | 0 | 0 | 0 | 0 | 0 | 0 | 0 | 0 | 0 |

Figure 7-30. Masked Parallel GPIO Pin Data Output Register (SIU_MPGPDO0 - SIU_MPGPDO31)
Table 7-51. SIU_MPGPDO0 - SIU_MPGPDO31 Field Descriptions

| Field | Description |
|----------------|---|
| 0–15 MASKx | Pin Data Out. Controls the write access to the corresponding GPDO. 0 Previous value defined by GPDO is maintain. 1 Corresponding GPDO is written with value defined by DATA field. |
| 16–31 DATAx | Pin Data Out. Stores the data to be driven out on the external GPIO pin controlled by this register. 0 Logic low value is driven on the pad interface data out signal for the corresponding GPIO pin when the pin is configured as an output. 1 Logic high value is driven on the pad interface data out signal for the corresponding GPIO pin when the pin is configured as an output. |

7.3.1.33 SIU DSPI Serialization Registers

Each bit in the DSPI serialized output frame can contain a signal routed from the output of one of three on-chip sources. The sources on this device are the eTPU module, eMIOS module, or a software-updated GPO data register. The mapping between module or data register and the output frame for a single DSPI channel is performed by independent 32-bit registers, one for each module that is mapped plus one for the data register. An example of how these registers are used to create the DSPI serialized output is shown below.

Example of Pin Multiplexing

eTPUB Select Register (for DSPI_A)

| | | | | | | | | | | | | | | | | | | | | | | | | | | | | | | | | |
|--------|----|----|----|----|----|----|---|---|---|---|----|----|----|----|----|----|----|----|----|----|----|----|----|----|----|----|----|----|----|----|----|----|
| | 0 | 1 | 2 | 3 | 4 | 5 | 6 | 7 | 8 | 9 | 10 | 11 | 12 | 13 | 14 | 15 | 16 | 17 | 18 | 19 | 20 | 21 | 22 | 23 | 24 | 25 | 26 | 27 | 28 | 29 | 30 | 31 |
| Chan# | 15 | 14 | 13 | 12 | 11 | 10 | 9 | 8 | 7 | 6 | 5 | 4 | 3 | 2 | 1 | 0 | 31 | 30 | 29 | 28 | 27 | 26 | 25 | 24 | 23 | 22 | 21 | 20 | 19 | 18 | 17 | 16 |
| Enable | 0 | 0 | 0 | 0 | 0 | 0 | 0 | 0 | 0 | 0 | 0 | 0 | 0 | 0 | 0 | 0 | 0 | 1 | 0 | 0 | 0 | 0 | 0 | 0 | 0 | 0 | 0 | 0 | 0 | 0 | 0 | 0 |

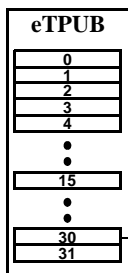

eMIOS Select Register (for DSPI_A)

| | | | | | | | | | | | | | | | | | | | | | | | | | | | | | | | | | |
|--------|---|---|---|---|---|---|---|---|---|---|----|----|----|----|----|----|----|----|----|----|----|----|----|----|----|----|----|----|----|----|----|----|---|
| | 0 | 1 | 2 | 3 | 4 | 5 | 6 | 7 | 8 | 9 | 10 | 11 | 12 | 13 | 14 | 15 | 16 | 17 | 18 | 19 | 20 | 21 | 22 | 23 | 24 | 25 | 26 | 27 | 28 | 29 | 30 | 31 | |
| Chan# | 7 | 6 | 5 | 4 | 3 | 2 | 1 | 0 | 8 | 9 | 10 | 11 | 12 | 13 | 14 | 15 | 16 | 17 | 18 | 19 | 20 | 21 | 22 | 23 | 0 | 1 | 2 | 3 | 4 | 5 | 6 | 7 | |
| Enable | 0 | 0 | 0 | 0 | 0 | 0 | 0 | 0 | 0 | 0 | 0 | 0 | 0 | 0 | 0 | 0 | 0 | 0 | 0 | 0 | 0 | 0 | 0 | 0 | 0 | 0 | 0 | 0 | 0 | 1 | 0 | 0 | 0 |

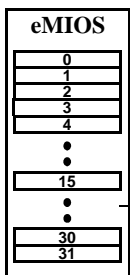

DSPIAH/L Select Register (for DSPI_A)

| | | | | | | | | | | | | | | | | | | | | | | | | | | | | | | | | | |
|--|---|---|---|---|---|---|---|---|---|---|----|----|----|----|----|----|----|----|----|----|----|----|----|----|----|----|----|----|----|----|----|----|---|
| | 0 | 1 | 2 | 3 | 4 | 5 | 6 | 7 | 8 | 9 | 10 | 11 | 12 | 13 | 14 | 15 | 16 | 17 | 18 | 19 | 20 | 21 | 22 | 23 | 24 | 25 | 26 | 27 | 28 | 29 | 30 | 31 | |
| | 0 | 1 | 2 | 3 | 4 | 5 | 6 | 7 | 8 | 9 | 10 | 11 | 12 | 13 | 14 | 15 | 16 | 17 | 18 | 19 | 20 | 21 | 22 | 23 | 24 | 25 | 26 | 27 | 28 | 29 | 30 | 31 | |
| | 0 | 0 | 0 | 0 | 0 | 0 | 0 | 0 | 0 | 0 | 0 | 0 | 0 | 0 | 0 | 0 | 0 | 0 | 0 | 0 | 0 | 0 | 0 | 0 | 0 | 0 | 0 | 0 | 0 | 1 | 0 | 0 | 0 |

SIU_DSPIAL[MASK17] Enable

SIU_DSPIAL[DATA17]

Serial GPO A

DSPIA Output Register

| | | | | | | | | | | | | | | | | | | | | | | | | | | | | | | | | |
|------------------------------|---|---|---|---|---|---|---|---|---|---|----|----|----|----|----|----|----|------------------|----|----|----|----|----|----|----|----|----|----|----|----|----|----|
| Frame bit | 0 | 1 | 2 | 3 | 4 | 5 | 6 | 7 | 8 | 9 | 10 | 11 | 12 | 13 | 14 | 15 | 16 | 17 | 18 | 19 | 20 | 21 | 22 | 23 | 24 | 25 | 26 | 27 | 28 | 29 | 30 | 31 |
| Function & Channel Selection | | | | | | | | | | | | | | | | | | eTPUB Channel 30 | | | | | | | | | | | | | | |

7.3.1.33.1 Masked Serial GPO Registers for DSPI (SIU_DSPIAH, SIU_DSPIAL, SIU_DSPIBH, SIU_DSPIBL, SIU_DSPICH, SIU_DSPICL, SIU_DSPIDH, SIU_DSPIDL)

These registers are written by software to drive data out on the serialization module described in the [Figure 7-35](#), [Figure 7-38](#), [Figure 7-41](#), [Figure 7-45](#). The purpose of these registers is to allow any combination of bits in each half of the 32 bit serialized data frame to be updated with a single 32-bit write operation, while allowing other bits to maintain their previous state. This is accomplished by writing a 16 bit masked value coherently with an update value contained in a 16 bit output field, and only updating those bits in the output register for which the corresponding mask bit is set.

Table 7-52. SIU Address Map for Masked Serial Output and Serial Selection Registers

| Address | Use |
|--------------------------------------|------------------------------------|
| SIU_BASE + 0x0D00 -SIU_BASE + 0x0D03 | DSPIA GP Mask-Output High Register |
| SIU_BASE + 0x0D04 -SIU_BASE + 0x0D07 | DSPIA GP Mask-Output Low Register |
| SIU_BASE + 0x0D08 -SIU_BASE + 0x0D0B | DSPIB GP Mask-Output High Register |
| SIU_BASE + 0x0D0C -SIU_BASE + 0x0D0F | DSPIB GP Mask-Output Low Register |
| SIU_BASE + 0x0D10 -SIU_BASE + 0x0D13 | DSPIC GP Mask-Output High Register |
| SIU_BASE + 0x0D14 -SIU_BASE + 0x0D17 | DSPIC GP Mask-Output Low Register |
| SIU_BASE + 0x0D18 -SIU_BASE + 0x0D1B | DSPID GP Mask-Output High Register |
| SIU_BASE + 0x0D1C -SIU_BASE + 0x0D1F | DSPID GP Mask-Output Low Register |
| SIU_BASE + 0x0D20 -SIU_BASE + 0x0D3F | Reserved |
| SIU_BASE + 0x0D40 -SIU_BASE + 0x0D43 | DSPIA eTPUB Select Register |
| SIU_BASE + 0x0D44 -SIU_BASE + 0x0D47 | DSPIA eMIOS Select Register |
| SIU_BASE + 0x0D48 -SIU_BASE + 0x0D4B | DSPIA GPO Select Register |
| SIU_BASE + 0x0D4C -SIU_BASE + 0x0D4F | Reserved |
| SIU_BASE + 0x0D50 -SIU_BASE + 0x0D53 | DSPIB eTPUA Select Register |
| SIU_BASE + 0x0D54 -SIU_BASE + 0x0D57 | DSPIB eMIOS Select Register |
| SIU_BASE + 0x0D58 -SIU_BASE + 0x0D5B | DSPIB GPO Select Register |
| SIU_BASE + 0x0D5C -SIU_BASE + 0x0D5F | Reserved |
| SIU_BASE + 0x0D60 -SIU_BASE + 0x0D63 | DSPIC eTPUA Select Register |
| SIU_BASE + 0x0D64 -SIU_BASE + 0x0D67 | DSPIC eMIOS Select Register |
| SIU_BASE + 0x0D68 -SIU_BASE + 0x0D6B | DSPIC GPO Select Register |
| SIU_BASE + 0x0D6C -SIU_BASE + 0x0D6F | Reserved |
| SIU_BASE + 0x0D70 -SIU_BASE + 0x0D73 | DSPID eTPUB Select Register |
| SIU_BASE + 0x0D74 -SIU_BASE + 0x0D77 | DSPID eMIOS Select Register |
| SIU_BASE + 0x0D78 -SIU_BASE + 0x0D7B | DSPID GPO Select Register |
| SIU_BASE + 0x0D7C -SIU_BASE + 0x0D7F | Reserved |
| SIU_BASE + 0x0D80 -SIU_BASE + 0x0DC0 | Reserved |

SIU_BASE + 0xD00, SIU_BASE + 0xD08, SIU_BASE + 0xD10, SIU_BASE + 0xD18

| | | | | | | | | | | | | | | | | |
|--------|------|------|------|------|------|------|------|------|------|------|------|------|------|------|------|------|
| | 0 | 1 | 2 | 3 | 4 | 5 | 6 | 7 | 8 | 9 | 10 | 11 | 12 | 13 | 14 | 15 |
| R | | | | | | | | | | | | | | | | |
| W | MASK | MASK | MASK | MASK | MASK | MASK | MASK | MASK | MASK | MASK | MASK | MASK | MASK | MASK | MASK | MASK |
| RESET: | 0 | 0 | 0 | 0 | 0 | 0 | 0 | 0 | 0 | 0 | 0 | 0 | 0 | 0 | 0 | 0 |
| | 16 | 17 | 18 | 19 | 20 | 21 | 22 | 23 | 24 | 25 | 26 | 27 | 28 | 29 | 30 | 31 |
| R | DATA | DATA | DATA | DATA | DATA | DATA | DATA | DATA | DATA | DATA | DATA | DATA | DATA | DATA | DATA | DATA |
| W | 0 | 1 | 2 | 3 | 4 | 5 | 6 | 7 | 8 | 9 | 10 | 11 | 12 | 13 | 14 | 15 |
| RESET: | 0 | 0 | 0 | 0 | 0 | 0 | 0 | 0 | 0 | 0 | 0 | 0 | 0 | 0 | 0 | 0 |

Figure 7-31. Masked Serial GPO Register for DSPI - DSPI_A/B/C/D GPO Mask Output High Register (SIU_DSPIAH/SIU_DSPIBH/SIU_DSPICH/SIU_DSPIDH)
SIU_BASE + 0xD04, SIU_BASE + 0xD0C, SIU_BASE + 0xD14, SIU_BASE + 0xD1C

| | | | | | | | | | | | | | | | | |
|--------|------|------|------|------|------|------|------|------|------|------|------|------|------|------|------|------|
| | 0 | 1 | 2 | 3 | 4 | 5 | 6 | 7 | 8 | 9 | 10 | 11 | 12 | 13 | 14 | 15 |
| R | | | | | | | | | | | | | | | | |
| W | MASK | MASK | MASK | MASK | MASK | MASK | MASK | MASK | MASK | MASK | MASK | MASK | MASK | MASK | MASK | MASK |
| RESET: | 0 | 0 | 0 | 0 | 0 | 0 | 0 | 0 | 0 | 0 | 0 | 0 | 0 | 0 | 0 | 0 |
| | 16 | 17 | 18 | 19 | 20 | 21 | 22 | 23 | 24 | 25 | 26 | 27 | 28 | 29 | 30 | 31 |
| R | DATA | DATA | DATA | DATA | DATA | DATA | DATA | DATA | DATA | DATA | DATA | DATA | DATA | DATA | DATA | DATA |
| W | 16 | 17 | 18 | 19 | 20 | 21 | 22 | 23 | 24 | 25 | 26 | 27 | 28 | 29 | 30 | 31 |
| RESET: | 0 | 0 | 0 | 0 | 0 | 0 | 0 | 0 | 0 | 0 | 0 | 0 | 0 | 0 | 0 | 0 |

Figure 7-32. Masked Serial GPO Register for DSPI - DSPI_A/B/C/D GPO Mask Output Low Register (SIU_DSPIAL/SIU_DSPIBL/SIU_DSPICL/SIU_DSPIDL)
Table 7-53. SIU_DSPIAL/SIU_DSPIBL/SIU_DSPICL/SIU_DSPIDL Field Descriptions

| Field | Description |
|----------------|---|
| 0–15 MASKx | Pin Data Out. Controls the write access to the corresponding GPO for DSPI. These bits are write-only and read as 0. 0 Previous value defined by GPDO is maintained. 1 Corresponding GPO is written with value defined by DATA field. Note: The MASK bits have to be written at the same time (same access cycle) as the DATA bits, for the mask to work (the MASK information is not stored). |
| 16–31 DATAx | Pin Data Out. Stores the data to be driven out on the external GPIO pin controlled by this register. 0 Logic low value is driven on the pad interface data out signal for the corresponding GPO for DSPI when this output is selected in the DSPI serialization module. 1 Logic high value is driven on the pad interface data out signal for the corresponding GPO for DSPI when this output is selected in the DSPI serialization module. |

7.3.1.33.2 Serialized Output Signal Selection Registers for DSPI_A

The following three registers are used by DSPI_A to select the sources of the serialized output when running in DSI or CSI configuration.

Each register bit enables a path from the eTPU_B channel, eMIOS channel and data register bit SIU_DSPIAH/SIU_DSPIAL to the equivalent bit position in the DSPI_A serialized output frame. The user must ensure that bit selections from each of these registers do not overlap. Multiple sources are

logically ORed, which provides the potential for combining outputs from multiple timer channels and data registers to produce more complex bit behavior.

SIU_BASE + 0xD40

| | | | | | | | | | | | | | | | | |
|--------|-------|-------|-------|-------|-------|-------|-------|-------|-------|-------|-------|-------|-------|-------|-------|-------|
| | 0 | 1 | 2 | 3 | 4 | 5 | 6 | 7 | 8 | 9 | 10 | 11 | 12 | 13 | 14 | 15 |
| R | ETPUB | ETPUB | ETPUB | ETPUB | ETPUB | ETPUB | ETPUB | ETPUB | ETPUB | ETPUB | ETPUB | ETPUB | ETPUB | ETPUB | ETPUB | ETPUB |
| W | 15 | 14 | 13 | 12 | 11 | 10 | 9 | 8 | 7 | 6 | 5 | 4 | 3 | 2 | 1 | 0 |
| RESET: | 0 | 0 | 0 | 0 | 0 | 0 | 0 | 0 | 0 | 0 | 0 | 0 | 0 | 0 | 0 | 0 |
| | 16 | 17 | 18 | 19 | 20 | 21 | 22 | 23 | 24 | 25 | 26 | 27 | 28 | 29 | 30 | 31 |
| R | ETPUB | ETPUB | ETPUB | ETPUB | ETPUB | ETPUB | ETPUB | ETPUB | ETPUB | ETPUB | ETPUB | ETPUB | ETPUB | ETPUB | ETPUB | ETPUB |
| W | 31 | 30 | 29 | 28 | 27 | 26 | 25 | 24 | 23 | 22 | 21 | 20 | 19 | 18 | 17 | 16 |
| RESET: | 0 | 0 | 0 | 0 | 0 | 0 | 0 | 0 | 0 | 0 | 0 | 0 | 0 | 0 | 0 | 0 |

Figure 7-33. eTPU_B Select Register for DSPI_A (SIU_ETPUBA)

Table 7-54. SIU_ETPUBA Field Descriptions

| Field | Description |
|----------------|--|
| 0–31 ETPUBx | ETPUB channel select 0 This bit in the DSPI_A serialized output frame will not use the respective ETPUB channel 1 This bit in the DSPI_A serialized output frame will use the respective ETPUB channel |

SIU_BASE + 0xD44

| | | | | | | | | | | | | | | | | |
|--------|-------|-------|-------|-------|-------|-------|-------|-------|-------|-------|-------|-------|-------|-------|-------|-------|
| | 0 | 1 | 2 | 3 | 4 | 5 | 6 | 7 | 8 | 9 | 10 | 11 | 12 | 13 | 14 | 15 |
| R | EMIOS | EMIOS | EMIOS | EMIOS | EMIOS | EMIOS | EMIOS | EMIOS | EMIOS | EMIOS | EMIOS | EMIOS | EMIOS | EMIOS | EMIOS | EMIOS |
| W | 7 | 6 | 5 | 4 | 3 | 2 | 1 | 0 | 8 | 9 | 10 | 11 | 12 | 13 | 14 | 15 |
| RESET: | 0 | 0 | 0 | 0 | 0 | 0 | 0 | 0 | 0 | 0 | 0 | 0 | 0 | 0 | 0 | 0 |
| | 16 | 17 | 18 | 19 | 20 | 21 | 22 | 23 | 24 | 25 | 26 | 27 | 28 | 29 | 30 | 31 |
| R | EMIOS | EMIOS | EMIOS | EMIOS | EMIOS | EMIOS | EMIOS | EMIOS | EMIOS | EMIOS | EMIOS | EMIOS | EMIOS | EMIOS | EMIOS | EMIOS |
| W | 16 | 17 | 18 | 19 | 20 | 21 | 22 | 23 | 0 | 1 | 2 | 3 | 4 | 5 | 6 | 7 |
| RESET: | 0 | 0 | 0 | 0 | 0 | 0 | 0 | 0 | 0 | 0 | 0 | 0 | 0 | 0 | 0 | 0 |

Figure 7-34. eMIOS Select Register for DSPI_A (SIU_EMIOA)

Table 7-55. SIU_EMIOA Field Descriptions

| Field | Description |
|----------------|--|
| 0–31 EMIOSx | EMIOS channel select 0 This bit in the DSPI_A serialized output frame will not use the respective EMIOS channel 1 This bit in the DSPI_A serialized output frame will use the respective EMIOS channel |

SIU_BASE + 0xD48

| | | | | | | | | | | | | | | | | |
|--------|---------|---------|---------|---------|---------|---------|---------|---------|---------|---------|---------|---------|---------|---------|---------|---------|
| | 0 | 1 | 2 | 3 | 4 | 5 | 6 | 7 | 8 | 9 | 10 | 11 | 12 | 13 | 14 | 15 |
| R | DSPI AH | DSPI AH | DSPI AH | DSPI AH | DSPI AH | DSPI AH | DSPI AH | DSPI AH | DSPI AH | DSPI AH | DSPI AH | DSPI AH | DSPI AH | DSPI AH | DSPI AH | DSPI AH |
| W | 0 | 1 | 2 | 3 | 4 | 5 | 6 | 7 | 8 | 9 | 10 | 11 | 12 | 13 | 14 | 15 |
| RESET: | 0 | 0 | 0 | 0 | 0 | 0 | 0 | 0 | 0 | 0 | 0 | 0 | 0 | 0 | 0 | 0 |
| | 16 | 17 | 18 | 19 | 20 | 21 | 22 | 23 | 24 | 25 | 26 | 27 | 28 | 29 | 30 | 31 |
| R | DSPI AL | DSPI AL | DSPI AL | DSPI AL | DSPI AL | DSPI AL | DSPI AL | DSPI AL | DSPI AL | DSPI AL | DSPI AL | DSPI AL | DSPI AL | DSPI AL | DSPI AL | DSPI AL |
| W | 16 | 17 | 18 | 19 | 20 | 21 | 22 | 23 | 24 | 25 | 26 | 27 | 28 | 29 | 30 | 31 |
| RESET: | 0 | 0 | 0 | 0 | 0 | 0 | 0 | 0 | 0 | 0 | 0 | 0 | 0 | 0 | 0 | 0 |

Figure 7-35. SIU_DSPIAH/L Select Register for DSPI_A (SIU_DSPIAHLA)
Table 7-56. SIU_DSPIAHLA Field Descriptions

| Field | Description |
|-------------------|---|
| 0–31 DSPIAH/Lx | DSPI_A Data Register bit 0 The corresponding serial GPO A output (from the SIU_DSPIAH/L register) is disabled 1 The corresponding serial GPO A output (from the SIU_DSPIAH/L register) is enabled |

7.3.1.33.3 Serialized Output Signal Selection Registers for DSPI_B

The following three registers are used by DSPI_B to select the sources of the serialized output when running in DSI or CSI configuration.

Each register bit enables a path from the eTPU_A channel, eMIOS channel and data register bit SIU_DSPIBH/SIU_DSPIBL to the equivalent bit position in the DSPI_B serialized output frame. The user must ensure that bit selections from each of these registers do not overlap. Multiple sources are logically ORed, which provides the potential for combining outputs from multiple timer channels and data registers to produce more complex bit behavior.

SIU_BASE + 0xD50

| | | | | | | | | | | | | | | | | |
|--------|-------|-------|-------|-------|-------|-------|-------|-------|-------|-------|-------|-------|-------|-------|-------|-------|
| | 0 | 1 | 2 | 3 | 4 | 5 | 6 | 7 | 8 | 9 | 10 | 11 | 12 | 13 | 14 | 15 |
| R | ETPUA | ETPUA | ETPUA | ETPUA | ETPUA | ETPUA | ETPUA | ETPUA | ETPUA | ETPUA | ETPUA | ETPUA | ETPUA | ETPUA | ETPUA | ETPUA |
| W | 23 | 22 | 21 | 20 | 19 | 18 | 17 | 16 | 29 | 28 | 27 | 26 | 25 | 24 | 31 | 30 |
| RESET: | 0 | 0 | 0 | 0 | 0 | 0 | 0 | 0 | 0 | 0 | 0 | 0 | 0 | 0 | 0 | 0 |
| | 16 | 17 | 18 | 19 | 20 | 21 | 22 | 23 | 24 | 25 | 26 | 27 | 28 | 29 | 30 | 31 |
| R | ETPUA | ETPUA | ETPUA | ETPUA | ETPUA | ETPUA | ETPUA | ETPUA | ETPUA | ETPUA | ETPUA | ETPUA | ETPUA | ETPUA | ETPUA | ETPUA |
| W | 12 | 13 | 14 | 15 | 0 | 1 | 2 | 3 | 4 | 5 | 6 | 7 | 8 | 9 | 10 | 11 |
| RESET: | 0 | 0 | 0 | 0 | 0 | 0 | 0 | 0 | 0 | 0 | 0 | 0 | 0 | 0 | 0 | 0 |

Figure 7-36. eTPU_A Select Register for DSPI_B (SIU_ETPUAB)
Table 7-57. SIU_ETPUAB Field Descriptions

| Field | Description |
|----------------|--|
| 0–31 ETPUAx | ETPUA channel select 0 This bit in the DSPI_B serialized output frame will not use the respective ETPUA channel 1 This bit in the DSPI_B serialized output frame will use the respective ETPUA channel |

SIU_BASE + 0xD54

| | | | | | | | | | | | | | | | | |
|--------|-------|-------|-------|-------|-------|-------|-------|-------|-------|-------|-------|-------|-------|-------|-------|-------|
| | 0 | 1 | 2 | 3 | 4 | 5 | 6 | 7 | 8 | 9 | 10 | 11 | 12 | 13 | 14 | 15 |
| R | EMIOS | EMIOS | EMIOS | EMIOS | EMIOS | EMIOS | EMIOS | EMIOS | EMIOS | EMIOS | EMIOS | EMIOS | EMIOS | EMIOS | EMIOS | EMIOS |
| W | 11 | 10 | 9 | 8 | 6 | 5 | 4 | 3 | 2 | 1 | 0 | 23 | 15 | 14 | 13 | 12 |
| RESET: | 0 | 0 | 0 | 0 | 0 | 0 | 0 | 0 | 0 | 0 | 0 | 0 | 0 | 0 | 0 | 0 |
| | 16 | 17 | 18 | 19 | 20 | 21 | 22 | 23 | 24 | 25 | 26 | 27 | 28 | 29 | 30 | 31 |
| R | EMIOS | EMIOS | EMIOS | EMIOS | EMIOS | EMIOS | EMIOS | EMIOS | EMIOS | EMIOS | EMIOS | EMIOS | EMIOS | EMIOS | EMIOS | EMIOS |
| W | 23 | 15 | 14 | 13 | 12 | 11 | 10 | 9 | 8 | 6 | 5 | 4 | 3 | 2 | 1 | 0 |
| RESET: | 0 | 0 | 0 | 0 | 0 | 0 | 0 | 0 | 0 | 0 | 0 | 0 | 0 | 0 | 0 | 0 |

Figure 7-37. eMIOS Select Register for DSPI_B (SIU_EMIOSB)

Table 7-58. SIU_EMIOSB Field Descriptions

| Field | Description |
|----------------|--|
| 0–31 EMIOSx | EMIOS channel select 0 This bit in the DSPI_B serialized output frame will not use the respective EMIOS channel 1 This bit in the DSPI_B serialized output frame will use the respective EMIOS channel |

SIU_BASE + 0xD58

| | | | | | | | | | | | | | | | | |
|--------|------|------|------|------|------|------|------|------|------|------|------|------|------|------|------|------|
| | 0 | 1 | 2 | 3 | 4 | 5 | 6 | 7 | 8 | 9 | 10 | 11 | 12 | 13 | 14 | 15 |
| R | DSPI | DSPI | DSPI | DSPI | DSPI | DSPI | DSPI | DSPI | DSPI | DSPI | DSPI | DSPI | DSPI | DSPI | DSPI | DSPI |
| W | BH | BH | BH | BH | BH | BH | BH | BH | BH | BH | BH | BH | BH | BH | BH | BH |
| RESET: | 0 | 0 | 0 | 0 | 0 | 0 | 0 | 0 | 0 | 0 | 0 | 0 | 0 | 0 | 0 | 0 |
| | 16 | 17 | 18 | 19 | 20 | 21 | 22 | 23 | 24 | 25 | 26 | 27 | 28 | 29 | 30 | 31 |
| R | DSPI | DSPI | DSPI | DSPI | DSPI | DSPI | DSPI | DSPI | DSPI | DSPI | DSPI | DSPI | DSPI | DSPI | DSPI | DSPI |
| W | BL | BL | BL | BL | BL | BL | BL | BL | BL | BL | BL | BL | BL | BL | BL | BL |
| RESET: | 0 | 0 | 0 | 0 | 0 | 0 | 0 | 0 | 0 | 0 | 0 | 0 | 0 | 0 | 0 | 0 |

Figure 7-38. SIU_DSPIBH/L Select Register for DSPI_B (SIU_DSPIBHLB)

Table 7-59. SIU_DSPIBHLB Field Descriptions

| Field | Description |
|-------------------|---|
| 0–31 DSPIBH/Lx | DSPI_B Data Register bit 0 The corresponding serial GPO B output (from the SIU_DSPIBH/L register) is disabled 1 The corresponding serial GPO B output (from the SIU_DSPIBH/L register) is enabled |

7.3.1.33.4 Serialized Output Signal Selection Registers for DSPI_C

The following three registers are used by DSPI_C to select the sources of the serialized output when running in DSI or CSI configuration.

Each register bit enables a path from the eTPU_A channel, eMIOS channel and data register bit SIU_DSPICH/SIU_DSPICL to the equivalent bit position in the DSPI_C serialized output frame. The user must ensure that bit selections from each of these registers do not overlap. Multiple sources are logically ORed, which provides the potential for combining outputs from multiple timer channels and data registers to produce more complex bit behavior.

SIU_BASE + 0xD60

| | | | | | | | | | | | | | | | | |
|--------|-------|-------|-------|-------|-------|-------|-------|-------|-------|-------|-------|-------|-------|-------|-------|-------|
| | 0 | 1 | 2 | 3 | 4 | 5 | 6 | 7 | 8 | 9 | 10 | 11 | 12 | 13 | 14 | 15 |
| R | ETPUA | ETPUA | ETPUA | ETPUA | ETPUA | ETPUA | ETPUA | ETPUA | ETPUA | ETPUA | ETPUA | ETPUA | ETPUA | ETPUA | ETPUA | ETPUA |
| W | 12 | 13 | 14 | 15 | 0 | 1 | 2 | 3 | 4 | 5 | 6 | 7 | 8 | 9 | 10 | 11 |
| RESET: | 0 | 0 | 0 | 0 | 0 | 0 | 0 | 0 | 0 | 0 | 0 | 0 | 0 | 0 | 0 | 0 |
| | 16 | 17 | 18 | 19 | 20 | 21 | 22 | 23 | 24 | 25 | 26 | 27 | 28 | 29 | 30 | 31 |
| R | ETPUA | ETPUA | ETPUA | ETPUA | ETPUA | ETPUA | ETPUA | ETPUA | ETPUA | ETPUA | ETPUA | ETPUA | ETPUA | ETPUA | ETPUA | ETPUA |
| W | 23 | 22 | 21 | 20 | 19 | 18 | 17 | 16 | 29 | 28 | 27 | 26 | 25 | 24 | 31 | 30 |
| RESET: | 0 | 0 | 0 | 0 | 0 | 0 | 0 | 0 | 0 | 0 | 0 | 0 | 0 | 0 | 0 | 0 |

Figure 7-39. eTPU_A Select Register for DSPI_C (SIU_ETPUAC)
Table 7-60. SIU_ETPUAC Field Descriptions

| Field | Description |
|----------------|--|
| 0–31 ETPUAx | ETPUA channel select 0 This bit in the DSPI_C serialized output frame will not use the respective ETPUA channel 1 This bit in the DSPI_C serialized output frame will use the respective ETPUA channel |

SIU_BASE + 0xD64

| | | | | | | | | | | | | | | | | |
|--------|-------|-------|-------|-------|-------|-------|-------|-------|-------|-------|-------|-------|-------|-------|-------|-------|
| | 0 | 1 | 2 | 3 | 4 | 5 | 6 | 7 | 8 | 9 | 10 | 11 | 12 | 13 | 14 | 15 |
| R | EMIOS | EMIOS | EMIOS | EMIOS | EMIOS | EMIOS | EMIOS | EMIOS | EMIOS | EMIOS | EMIOS | EMIOS | EMIOS | EMIOS | EMIOS | EMIOS |
| W | 12 | 13 | 14 | 15 | 23 | 0 | 1 | 2 | 3 | 4 | 5 | 6 | 8 | 9 | 10 | 11 |
| RESET: | 0 | 0 | 0 | 0 | 0 | 0 | 0 | 0 | 0 | 0 | 0 | 0 | 0 | 0 | 0 | 0 |
| | 16 | 17 | 18 | 19 | 20 | 21 | 22 | 23 | 24 | 25 | 26 | 27 | 28 | 29 | 30 | 31 |
| R | EMIOS | EMIOS | EMIOS | EMIOS | EMIOS | EMIOS | EMIOS | EMIOS | EMIOS | EMIOS | EMIOS | EMIOS | EMIOS | EMIOS | EMIOS | EMIOS |
| W | 23 | 22 | 21 | 20 | 19 | 18 | 17 | 16 | 29 | 28 | 27 | 26 | 25 | 24 | 31 | 30 |
| RESET: | 0 | 0 | 0 | 0 | 0 | 0 | 0 | 0 | 0 | 0 | 0 | 0 | 0 | 0 | 0 | 0 |

Figure 7-40. eMIOS Select Register for DSPI_C (SIU_EMIOSC)
Table 7-61. SIU_EMIOSC Field Descriptions

| Field | Description |
|----------------|--|
| 0–31 EMIOSx | EMIOS channel select 0 This bit in the DSPI_C serialized output frame will not use the respective EMIOS channel 1 This bit in the DSPI_C serialized output frame will use the respective EMIOS channel |

SIU_BASE + 0xD68

| | | | | | | | | | | | | | | | | |
|--------|---------|---------|---------|---------|---------|---------|---------|---------|---------|---------|---------|---------|---------|---------|---------|---------|
| | 0 | 1 | 2 | 3 | 4 | 5 | 6 | 7 | 8 | 9 | 10 | 11 | 12 | 13 | 14 | 15 |
| R | DSPI CH | DSPI CH | DSPI CH | DSPI CH | DSPI CH | DSPI CH | DSPI CH | DSPI CH | DSPI CH | DSPI CH | DSPI CH | DSPI CH | DSPI CH | DSPI CH | DSPI CH | DSPI CH |
| W | 0 | 1 | 2 | 3 | 4 | 5 | 6 | 7 | 8 | 9 | 10 | 11 | 12 | 13 | 14 | 15 |
| RESET: | 0 | 0 | 0 | 0 | 0 | 0 | 0 | 0 | 0 | 0 | 0 | 0 | 0 | 0 | 0 | 0 |
| | 16 | 17 | 18 | 19 | 20 | 21 | 22 | 23 | 24 | 25 | 26 | 27 | 28 | 29 | 30 | 31 |
| R | DSPI CL | DSPI CL | DSPI CL | DSPI CL | DSPI CL | DSPI CL | DSPI CL | DSPI CL | DSPI CL | DSPI CL | DSPI CL | DSPI CL | DSPI CL | DSPI CL | DSPI CL | DSPI CL |
| W | 16 | 17 | 18 | 19 | 20 | 21 | 22 | 23 | 24 | 25 | 26 | 27 | 28 | 29 | 30 | 31 |
| RESET: | 0 | 0 | 0 | 0 | 0 | 0 | 0 | 0 | 0 | 0 | 0 | 0 | 0 | 0 | 0 | 0 |

Figure 7-41. SIU_DSPICH/L Select Register for DSPI_C (SIU_DSPICHL)

Table 7-62. SIU_DSPICHL Field Descriptions

| Field | Description |
|-------------------|---|
| 0–31 DSPICH/Lx | DSPI_C Data Register bit 0 The corresponding serial GPO C output (from the SIU_DSPICH/L register) is disabled 1 The corresponding serial GPO C output (from the SIU_DSPICH/L register) is enabled |

SIU_BASE + 0xD6C

| | | | | | | | | | | | | | | | | |
|--------|-------|-------|-------|-------|-------|-------|-------|-------|-------|-------|-------|-------|-------|-------|-------|-------|
| | 0 | 1 | 2 | 3 | 4 | 5 | 6 | 7 | 8 | 9 | 10 | 11 | 12 | 13 | 14 | 15 |
| R | ETPUB | ETPUB | ETPUB | ETPUB | ETPUB | ETPUB | ETPUB | ETPUB | ETPUB | ETPUB | ETPUB | ETPUB | ETPUB | ETPUB | ETPUB | ETPUB |
| W | 12 | 13 | 14 | 15 | 0 | 1 | 2 | 3 | 4 | 5 | 6 | 7 | 8 | 9 | 10 | 11 |
| RESET: | 0 | 0 | 0 | 0 | 0 | 0 | 0 | 0 | 0 | 0 | 0 | 0 | 0 | 0 | 0 | 0 |
| | 16 | 17 | 18 | 19 | 20 | 21 | 22 | 23 | 24 | 25 | 26 | 27 | 28 | 29 | 30 | 31 |
| R | ETPUB | ETPUB | ETPUB | ETPUB | ETPUB | ETPUB | ETPUB | ETPUB | ETPUB | ETPUB | ETPUB | ETPUB | ETPUB | ETPUB | ETPUB | ETPUB |
| W | 23 | 22 | 21 | 20 | 19 | 18 | 17 | 16 | 29 | 28 | 27 | 26 | 25 | 24 | 31 | 30 |
| RESET: | 0 | 0 | 0 | 0 | 0 | 0 | 0 | 0 | 0 | 0 | 0 | 0 | 0 | 0 | 0 | 0 |

Figure 7-42. eTPU_B Select Register for DSPI_C (SIU_ETPUBC)

Table 7-63. SIU_ETPUAC Field Descriptions

| Field | Description |
|----------------|--|
| 0–31 ETPUAx | ETPUA channel select 0 This bit in the DSPI_C serialized output frame will not use the respective ETPUA channel 1 This bit in the DSPI_C serialized output frame will use the respective ETPUA channel |

7.3.1.34 Serialized Output Signal Selection Registers for DSPI_D

The following registers are used by DSPI_D to select the sources of the serialized output when running in DSI or CSI configuration.

The register bit enables a path from the eTPU_B channel or eMIOS channel to the equivalent bit position in the DSPI_D serialized output frame. The user must ensure that bit selections from each of these registers do not overlap. Multiple sources are logically ORed, which provides the potential for combining outputs from multiple timer channels and data registers to produce more complex bit behavior.

SIU_BASE + 0xD70

| | | | | | | | | | | | | | | | | |
|--------|-------|-------|-------|-------|-------|-------|----|----|----|----|-------|-------|-------|-------|-------|-------|
| | 0 | 1 | 2 | 3 | 4 | 5 | 6 | 7 | 8 | 9 | 10 | 11 | 12 | 13 | 14 | 15 |
| R | ETPUB | ETPUB | ETPUB | ETPUB | ETPUB | ETPUB | 0 | 0 | 0 | 0 | ETPUB | ETPUB | ETPUB | ETPUB | ETPUB | ETPUB |
| W | 21 | 20 | 19 | 18 | 17 | 16 | | | | | 29 | 28 | 27 | 26 | 25 | 24 |
| RESET: | 0 | 0 | 0 | 0 | 0 | 0 | 0 | 0 | 0 | 0 | 0 | 0 | 0 | 0 | 0 | 0 |
| | 16 | 17 | 18 | 19 | 20 | 21 | 22 | 23 | 24 | 25 | 26 | 27 | 28 | 29 | 30 | 31 |
| R | 0 | 0 | 0 | 0 | 0 | 0 | 0 | 0 | 0 | 0 | 0 | 0 | 0 | 0 | 0 | 0 |
| W | | | | | | | | | | | | | | | | |
| RESET: | 0 | 0 | 0 | 0 | 0 | 0 | 0 | 0 | 0 | 0 | 0 | 0 | 0 | 0 | 0 | 0 |

Figure 7-43. eTPU_B Select Register for DSPI_D (SIU_ETPUBD)
Table 7-64. SIU_ETPUAD Field Descriptions

| Field | Description |
|----------------|--|
| 0–31 ETPUBx | ETPUB channel select 0 This bit in the DSPI_D serialized output frame will not use the respective ETPUB channel 1 This bit in the DSPI_D serialized output frame will use the respective ETPUB channel |

SIU_BASE + 0xD74

| | | | | | | | | | | | | | | | | |
|--------|----|----|----|----|----|----|-------|-------|-------|-------|----|----|----|----|----|----|
| | 0 | 1 | 2 | 3 | 4 | 5 | 6 | 7 | 8 | 9 | 10 | 11 | 12 | 13 | 14 | 15 |
| R | 0 | 0 | 0 | 0 | 0 | 0 | EMIOS | EMIOS | EMIOS | EMIOS | 0 | 0 | 0 | 0 | 0 | 0 |
| W | | | | | | | 11 | 10 | 13 | 12 | | | | | | |
| RESET: | 0 | 0 | 0 | 0 | 0 | 0 | 0 | 0 | 0 | 0 | 0 | 0 | 0 | 0 | 0 | 0 |
| | 16 | 17 | 18 | 19 | 20 | 21 | 22 | 23 | 24 | 25 | 26 | 27 | 28 | 29 | 30 | 31 |
| R | 0 | 0 | 0 | 0 | 0 | 0 | 0 | 0 | 0 | 0 | 0 | 0 | 0 | 0 | 0 | 0 |
| W | | | | | | | | | | | | | | | | |
| RESET: | 0 | 0 | 0 | 0 | 0 | 0 | 0 | 0 | 0 | 0 | 0 | 0 | 0 | 0 | 0 | 0 |

Figure 7-44. eMIOS Select Register for DSPI_D (SIU_EMIOSD)
Table 7-65. SIU_EMIOSD Field Descriptions

| Field | Description |
|----------------|--|
| 0–31 EMIOSx | EMIOS channel select 0 This bit in the DSPI_D serialized output frame will not use the respective EMIOS channel 1 This bit in the DSPI_D serialized output frame will use the respective EMIOS channel |

SIU_BASE + 0xD78

| | | | | | | | | | | | | | | | | |
|--------|----|----|----|----|----|----|----|----|----|----|----|----|----|----|----|----|
| | 0 | 1 | 2 | 3 | 4 | 5 | 6 | 7 | 8 | 9 | 10 | 11 | 12 | 13 | 14 | 15 |
| R | 0 | 0 | 0 | 0 | 0 | 0 | 0 | 0 | 0 | 0 | 0 | 0 | 0 | 0 | 0 | 0 |
| W | | | | | | | | | | | | | | | | |
| RESET: | 0 | 0 | 0 | 0 | 0 | 0 | 0 | 0 | 0 | 0 | 0 | 0 | 0 | 0 | 0 | 0 |
| | 16 | 17 | 18 | 19 | 20 | 21 | 22 | 23 | 24 | 25 | 26 | 27 | 28 | 29 | 30 | 31 |
| R | 0 | 0 | 0 | 0 | 0 | 0 | 0 | 0 | 0 | 0 | 0 | 0 | 0 | 0 | 0 | 0 |
| W | | | | | | | | | | | | | | | | |
| RESET: | 0 | 0 | 0 | 0 | 0 | 0 | 0 | 0 | 0 | 0 | 0 | 0 | 0 | 0 | 0 | 0 |

Figure 7-45. DSPIDH/L Select Register for DSPI_D (SIU_DSPIDHLD)

7.3.1.35 GPIO Pin Data Input Registers (SIU_GPDIO_3 - SIU_GPDI508_511) - Standard

Previous devices are limited to supporting a maximum of 256 general purpose input registers, and thus a maximum GPIO input assignment of GPIO[0:255]. The reason is that only 256 bytes of SIU address space is allocated for the GPIO Pin Data Input registers, and adjacent memory locations are unavailable.

To accommodate the extended number of the GPIO pads, this device has a new memory map definition of 512 bytes for allocating up to 512 GPIO Pin Data Input registers. For compatibility, the first used 256 GPIO Pin Data Input registers are mapped to both the old and new locations. The memory map is shown in [Table 7-66](#).

Table 7-66. GPIO Pin Data Input Registers Memory Map

| Address Offset from SIU_BASE | Number |
|------------------------------|---|
| 0x0E00 - 0x0E4A | Reserved |
| 0x0E4B - 0x0E6E | GPIO Pin Data Input Registers 75 - 110 |
| 0x0E6F - 0x0E70 | Reserved |
| 0x0E71 - 0x0ECC | GPIO Pin Data Input Registers 113- 204 |
| 0x0ECD - 0x0ECF | Reserved |
| 0x0ED0 - 0x0ED1 | GPIO Pin Data Input Registers 208- 209 |
| | Reserved |
| 0x0ED3 | GPIO Pin Data Input Registers 211 |
| | Reserved |
| 0x0ED5 | GPIO Pin Data Input Registers 213 |
| | Reserved |
| 0x0EE7 - 0x0EFD | GPIO Pin Data Input Registers 231 - 253 |
| | Reserved |
| 0x0F00 - 0x0F33 | GPIO Pin Data Input Registers 256 - 307 |
| | Reserved |
| 0x0FB0 - 0x0FB5 | GPIO Pin Data Input Registers 432 - 437 |
| | Reserved |
| 0x0FB8 - 0x0FD8 | GPIO Pin Data Input Registers 440 - 472 |
| | Reserved |

The GPDIX_x registers are read-only registers that allow reading of the input state of an external GPIO pin. Each byte of a register represents the input state of a single external GPIO pin. The first 256 GPDIX_x registers corresponds to the same GPDIO inputs described in [Section 7.3.1.15, GPIO Pin Data Input Registers 0–255 \(SIU_GPDIO_n\)](#).

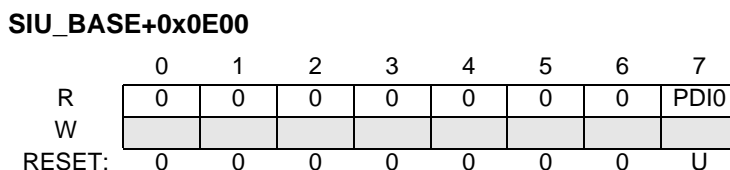

Figure 7-46. GPIO Pin Data In Register 0 (SIU_GPDIO)

SIU_BASE+0xFFC

| | | | | | | | | |
|--------|---|---|---|---|---|---|---|--------|
| | 0 | 1 | 2 | 3 | 4 | 5 | 6 | 7 |
| R | 0 | 0 | 0 | 0 | 0 | 0 | 0 | PDI511 |
| W | | | | | | | | |
| RESET: | 0 | 0 | 0 | 0 | 0 | 0 | 0 | U |

Figure 7-47. GPIO Pin Data In Register 511 (SIU_GPDI511)
Table 7-67. SIU_EMIOSD Field Descriptions

| Field | Description |
|--------------|--|
| 0–31 PDIx | This bit reflects the input state on the external GPIO pin for the register. If $PCR_n[IBE] = 1$, then: 0 Signal on pin is a logic 0 1 Signal on pin is a logic 1 |

7.4 Functional Description

The following sections provide a functional overview of the SIU operation.

7.4.1 Pad Configuration

The pad configuration registers (SIU_PCR) in the SIU allow software control over the following electrical characteristics of the external pads:

- Weak pullup/down enable/disable
- Weak pullup/down selection
- Slew-rate selection for outputs
- Drive strength selection for outputs
- Input buffer enable (when direction is configured for output)
- Input hysteresis enable/disable
- Open drain/push-pull output selection
- Multiplexed function selection
- Data direction selection

The pad configuration registers are provided to allow centralized control over external pins that are shared by more than one module. Each pad configuration register controls a single pin.

7.4.2 Reset Control

The reset controller logic is located in the SIU. Refer to [Section 7.2.1.1, Reset Input \(RESET\)](#), and [Section 7.2.1.2, Reset Output \(RSTOUT\)](#), for details on the reset operations.

7.4.2.1 Reset Boot Configuration

The BOOTCFG[0:1] pins are latched CFG_SAMPLE_CLKS prior to the negation of the $\overline{\text{RSTOUT}}$ pin, except in the case of a Software External Reset. The values latched are placed in the BOOTCFG field of the Reset Status Register. Refer to [Section 4.7.1.1, RCHW Overview](#), for details on the RCHW.

7.4.2.2 $\overline{\text{RESET}}$ Pin Glitch Detect

The reset controller provides a glitch detect feature on the $\overline{\text{RESET}}$ pin. If the reset controller detects that the $\overline{\text{RESET}}$ pin is asserted for more than two clock cycles, the event is latched. After the latch is set, if the $\overline{\text{RESET}}$ pin is negated before 10 clock cycles is reached, the reset controller sets the RGF bit without affecting any of the other bits in the reset status register (SIU_RSR). The latch is cleared when the RGF bit is set or a valid reset is recognized. The RGF bit remains set until cleared by a software or the $\overline{\text{RESET}}$ signal asserts for 10 clock cycles. The reset controller does not respond to assertions of the $\overline{\text{RESET}}$ pin if a reset cycle is already being processed.

7.4.3 External Interrupts

There are 16 external interrupt inputs $\overline{\text{IRQ}}[0]–\overline{\text{IRQ}}[15]$ to the SIU. The IRQ inputs can be configured for rising-edge events, falling-edge events, or both.

External interrupt requests are triggered by rising- and/or falling-edge events that are enabled by setting a bit in:

- IRQ rising-edge event enable register (SIU_IREER)
- IRQ falling-edge event enable register (SIU_IFEER)

If the bit is set in both registers, both rising- and falling-edge events trigger an interrupt request. Each IRQ has a counter that tracks the number of system clock cycles that occur between the rising- and falling-edge events. An IRQ counter exists for each IRQ rising- or falling-edge event enable bit.

The digital filter length field in the IRQ digital filter register (SIU_IDFR) specifies the minimum number of system clocks that the IRQ signal must hold a logic value to qualify the edge-triggered event as a valid state change. When the number of system clocks in the IRQ counter equals the value in the digital filter length field, the IRQ state latches and the IRQ counter is cleared.

If the previous filtered state of the IRQ does not match the current state, and the rising- or falling-edge event is enabled, the IRQ flag bit is set to 1. For example, the IRQ flag bit is set if a rising-edge event occurs under the following conditions:

- Previous filtered IRQ state was a logic 0
- Current latched IRQ state is a logic 1
- Rising-edge event is enabled for the IRQ

When the counter for an IRQ is not enabled, the state of the IRQ is held in the current and previous state latches. The IRQ counter operates independently of the IRQ or overrun flag bit. Clearing the IRQ flag or overrun flag bits does not clear or reload the counter.

Refer to the following sections for more information:

- [Section 7.3.1.4, External Interrupt Status Register \(SIU_EISR\)](#)
- [Section 7.3.1.9, IRQ Rising-Edge Event Enable Register \(SIU_IREER\)](#)
- [Section 7.3.1.10, IRQ Falling-Edge Event Enable Register \(SIU_IFEER\)](#)
- [Section 7.3.1.11, IRQ Digital Filter Register \(SIU_IDFR\)](#)

7.4.3.0.1 External Interrupts

The IRQ signals map to 16 independent interrupt requests output from the SIU. The IRQ flag bit is set when a rising-edge and/or falling-edge event occurs for the IRQ. An external IRQ signal is asserted when all of the following occur:

- Enable bit is set in the IRQ rising- and/or falling-edge event registers (SIU_IREER, SIU_IFEER)
- IRQ flag bit is set in the external interrupt status register (SIU_EISR)
- Enable bit is cleared in the DMA/Interrupt request enable register (SIU_DIRER)
- Select bit is cleared in the DMA/Interrupt select register (SIU_DIRSR)

The NMI pin function or platform SWT can generate either an NMI or a critical interrupt. When WKPCFG_NMI_GPIO213 is enabled as NMI, the pin will override the PCR configuration after reset. SIU_DIRER selects between critical and non maskable interrupt use, SIU_EISR reports status of NMI and SIU_IFEER selects edge sensitivity of NMI input

Refer to the following sections for more information:

- [Section 7.3.1.5, DMA/Interrupt Request Enable Register \(SIU_DIRER\)](#)
- [Section 7.3.1.6, DMA/Interrupt Request Select Register \(SIU_DIRSR\)](#)

7.4.3.0.2 DMA Transfers

DMA IRQ signals ($\overline{\text{IRQ}}[0]$ through $\overline{\text{IRQ}}[3]$) map to four independent DMA transfer *or* interrupt request outputs configured in the SIU. A DMA transfer or interrupt request asserts when all of the following occur:

- IRQ flag bit is set in the external interrupt status register (SIU_EISR)
- Enable bit is set in the DMA transfer or interrupt request enable register (SIU_DIRER)
- Select bit is set in the DMA transfer or interrupt request select register (SIU_DIRSR)

The SIU receives a ‘DMA transfer done’ signal for each DMA or interrupt request transmitted. When the ‘DMA done’ signal asserts, the IRQ flag bit is cleared.

Refer to the following sections for more information:

- [Section 7.3.1.5, DMA/Interrupt Request Enable Register \(SIU_DIRER\)](#)
- [Section 7.3.1.6, DMA/Interrupt Request Select Register \(SIU_DIRSR\)](#)

7.4.3.0.3 Overruns

An overrun IRQ exists for each overrun flag bit in the overrun status register (SIU_OSR).

An overrun IRQ asserts when all of the following occur:

- Enable bit is set in the IRQ rising- and/or falling-edge event registers (SIU_IREER, SIU_IFEER)
- IRQ flag bit is set in the external interrupt status register (SIU_EISR)
- Bit is set in the overrun request enable and overrun status registers (SIU_ORER, SIU_OSR)
- Rising- or falling-edge event triggers an interrupt request

The SIU outputs one overrun IRQ bit that is the logical OR of all of the IRQ overrun bits.

Refer to the following sections for more information:

- [Section 7.3.1.4, External Interrupt Status Register \(SIU_EISR\)](#)
- [Section 7.3.1.7, Overrun Status Register \(SIU_OSR\)](#)
- [Section 7.3.1.8, Overrun Request Enable Register \(SIU_ORER\)](#)

7.4.3.0.4 Edge-Detect Events

An IRQ asserts when an:

- Edge-detect event is enabled
- Edge-detect event occurs

To assert an IRQ when an edge-detect event occurs:

1. Set the enable bit in the IRQ rising- and falling-edge event enable registers (SIU_IREER, SIU_IFEER)
2. Clear the enable bits for the DMA/Interrupt request enable register (SIU_DIRER)

The IRQ bit is set in the external IRQ status register (SIU_EISR) when an edge-detect event occurs for that IRQ.

Refer to the following sections for more information:

- [Section 7.3.1.4, External Interrupt Status Register \(SIU_EISR\)](#)
- [Section 7.3.1.9, IRQ Rising-Edge Event Enable Register \(SIU_IREER\)](#)
- [Section 7.3.1.10, IRQ Falling-Edge Event Enable Register \(SIU_IFEER\)](#)

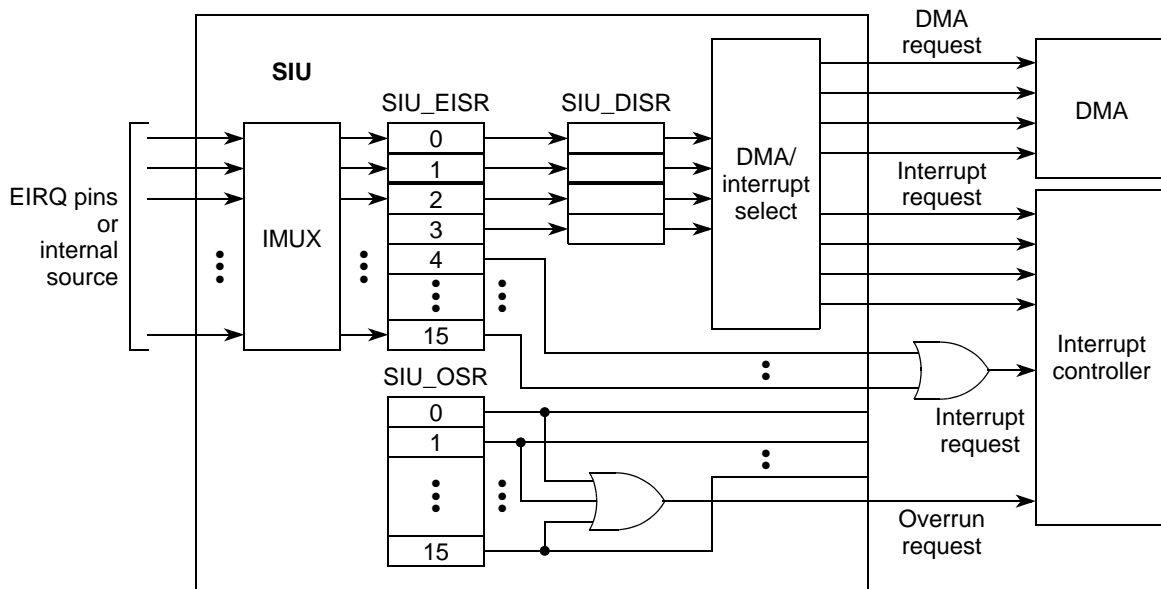

Figure 7-48. SIU DMA/Interrupt Request Diagram

7.4.4 GPIO Operation

All GPIO functions for the device are provided by the SIU. Each device pad that has a GPIO signal has a pin configuration register (PCR) in the SIU where the GPIO function is selected. In addition, each device GPIO signal has an input data register (SIU_GPDI n) and an output data register (SIU_GPDO n).

The SIU also implements several parallel GPIO registers (SIU_PGPDO x_x and SIU_PGPDIX x_x) that can be used to access up to 32 GPIO bits in a single- and word-sized accesses. The values read/written to these parallel registers are coherent with the data read/written to the SIU_GPDO x_x and SIU_GPDI x_x registers.

7.4.5 Internal Multiplexing

The internal multiplexing select registers (SIU_ISEL4-7, SIU_EIISR, and SIU_DISR) select the input source for the following components:

- eQADC command FIFO trigger sources.
- SIU external interrupt request signals
- DSPI signals used for chaining serial and parallel DSPI modules

A block diagram of the internal multiplexing feature is shown in [Figure 7-49](#). The figure shows the multiplexing of four external signals to an SIU output.

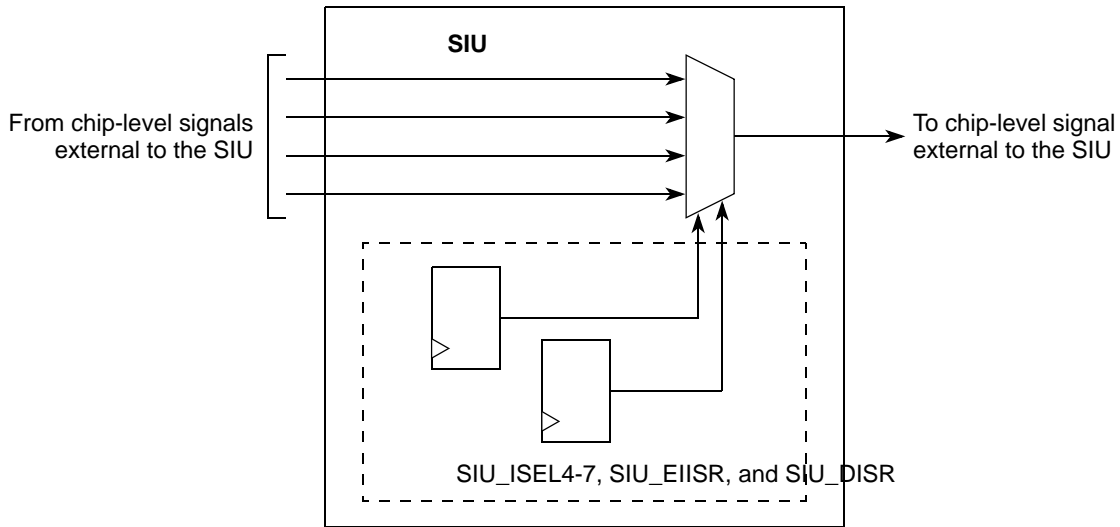

Figure 7-49. Four-to-One Internal Multiplexing Block Diagram

7.4.5.1 eQADC External Trigger Input Multiplexing

The eQADC external trigger inputs can connect to one of the following pins:

- External pin
- eTPU channel
- eMIOS channel
- Periodic interrupt timer

The input source for each eQADC external trigger is configured in the eQADC Command FIFO Trigger Source Select - IMUX Select Registers (SIU_ISEL4-7). For example, you can select one of the following signals to source the ETRIG[0] input trigger for the eQADC:

- TXDC_ETRIG[0]_GPIO[244] pin
- ETPUA[30] output channel
- EMIOS[10] output channel
- Extended trigger source selection (see [Table 7-27](#))

All ETRIG inputs are multiplexed in the same manner. If an eTPU or eMIOS channel is selected as an ETRIG input to the eQADC, you can activate the alternate function of that eTPU or eMIOS signal on the external pin.

An example of the multiplexing of an eQADC (EQADC_A) external trigger input is given below.

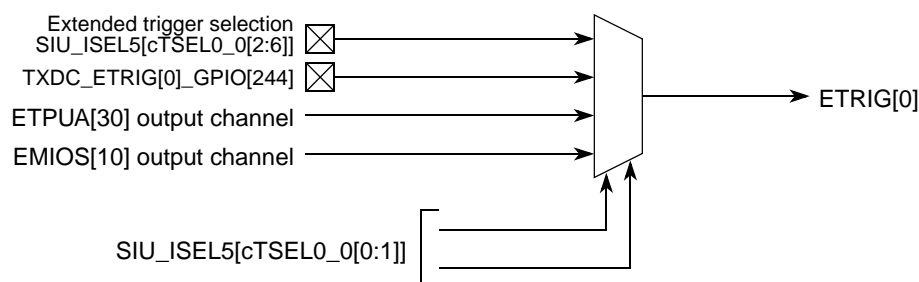

Figure 7-50. eQADC External Trigger Input Multiplexing

SIU_ISEL4-7 always provides one of four choices based on the most-significant two bits of each cTSEL field. When those bits are 0b00, the extended trigger selection is chosen and the remaining bits in cTSEL select among a longer list of trigger sources.

7.4.5.2 SIU External Interrupt Input Multiplexing

The sixteen SIU external interrupt inputs can be connected to either an external pin or to output signals from a DSPI module. The input source for each SIU external interrupt is individually specified in the external IRQ input select register (SIU_EIISR).

As shown in the following figure, the $\overline{\text{IRQ}}[0]$ input of the SIU can be connected to either the $\overline{\text{IRQ}}[0]_{\text{GPIO}}[450]$ pin, the PCSB[0] input signal, the PCSC[1] deserialized output signal, or the PCSD[2] deserialized output signal. The remaining IRQ inputs are multiplexed in the same manner. The inputs to the IRQ from each DSPI module are offset by one so that if more than one DSPI module is connected to the same external device type, a separate interrupt can be generated for each device. This also applies to DSPI modules connected to external devices of a different type that have status bits in the same bit location of the deserialized information.

An example of the multiplexing of an SIU external interrupt input is given in [Figure 7-51](#).

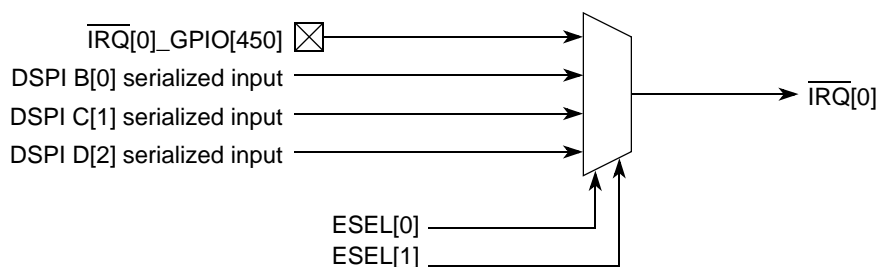

Figure 7-51. DSPI Serialized Input Multiplexing

7.4.5.3 Multiplexed Inputs for DSPI Multiple Transfer Operation

Each DSPI module can be combined in a serial or parallel chain (multiple transfer operation). Serial chaining allows SPI operation with an external device that has more bits than one DSPI module.

In a serial chain, one DSPI module operates as a master, the second, third, or fourth DSPI modules operate as slaves. The slave DSPI and external SPI device use the master peripheral chip select (PCS) and clock (SCK). The trigger input of the master allows a slave DSPI to trigger a transfer when a data change occurs in the slave DSPI and the slave DSPI is operating in change in data mode. The trigger input of the master is connected to the $\overline{\text{MTRIG}}$ output of the slave. If more than two DSPIs are chained in change in data mode, a chain must be connected of $\overline{\text{MTRIG}}$ outputs to trigger inputs through the slaves with the last slave $\overline{\text{MTRIG}}$ output connected to the master trigger input.

An example of a serial chain is shown in Figure 7-52.

Parallel chaining allows the PCS and SCK from one DSPI to be used by more than one external SPI device, thus reducing pin utilization of the device MCU. In this example, the SOUT and SIN of the two DSPIs connect to separate external SPI devices, which share a common PCS and SCK.

To support multiple transfer operation of the DSPIs, an input multiplexor is required for the SIN, $\overline{\text{SS}}$, SCK IN, and trigger signals of each DSPI. The input source for the SIN input of a DSPI can be a pin or the SOUT of any of the other three DSPIs. The input source for the $\overline{\text{SS}}$ input of a DSPI can be a pin or the PCSX[0] of any of the other three DSPIs. The input source for the SCK input of a DSPI can be a pin or the SCK output of any of the other three DSPIs. The input source for the trigger input can be the $\overline{\text{PCSS}}$ output of any of the other three DSPIs. The input source for each DSPI SIN, $\overline{\text{SS}}$, SCK, and trigger signal is individually specified in the DSPI input select register (SIU_DISR).

An example of a parallel chain is shown in Figure 7-53.

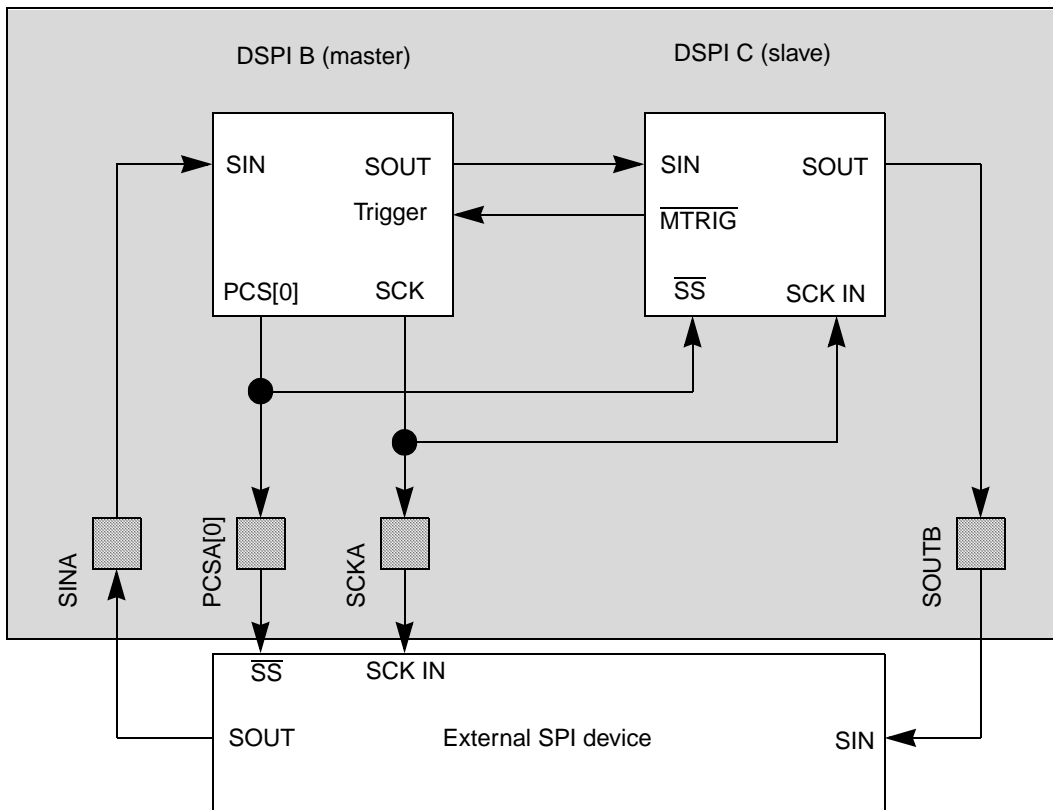

Figure 7-52. DSPI Serial Chaining

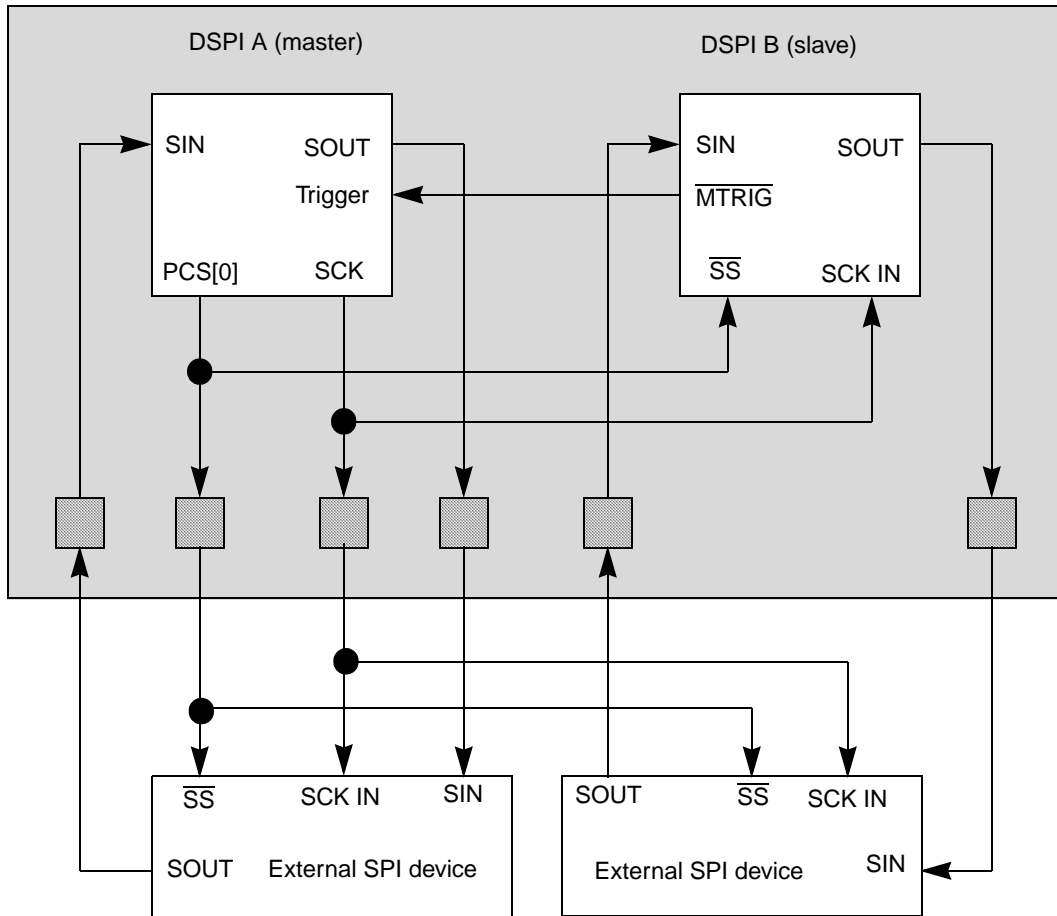

Figure 7-53. DSPI Parallel Chaining



Chapter 8

System Information Module

8.1 SIM Overview

The System Information Module (SIM) contains the calibration constants for the on-chip Temperature Sensor and a 128-bit Device ID constant that is unique to every chip. All values are read-only, and may not be changed by software.

Two 32-bit locations are reserved for temperature sensor calibration constants. A description of their usage is provided in the Temperature Sensor Chapter. The Unique Device ID is encoded and stored in four adjacent memory locations. There is no specific user information provided in the Device ID. [Table 8-1](#) shows the organization of the constants.

8.1.1 SIM Constants

Table 8-1. SIM Constants

| Offset from 0xFFFE_C000 | 0:15 | 16:31 |
|----------------------------|---|-------|
| 0x00 | Temperature sensor calibration constant | |
| 0x04 | Temperature sensor calibration constant | |
| 0x08 | Reserved | |
| 0x0C | | |
| 0x10 | Unique Device ID | |
| 0x14 | Unique Device ID | |
| 0x18 | Unique Device ID | |
| 0x1C | Unique Device ID | |
| 0x20 | Reserved | |
| 0x24 | | |
| 0x28 | | |
| 0x2C | | |
| 0x30 | | |
| 0x34 | | |
| 0x38 | | |
| 0x3C | | |



Chapter 9

Boot Assist Module (BAM)

9.1 Overview

The Boot Assist Module (BAM) is a 4-KB block of read-only memory, containing the boot program code for the MCU. The BAM program supports the following boot modes:

- Boot from internal flash
- Serial boot via SCI or CAN interface with optional baud-rate detection
- Boot from a memory connected to the MCU development bus (EBI¹) with multiplexed or separate address and data lines

The BAM program is executed by the MCU core just after the MCU resets. Depending on the boot mode, the program initializes the appropriate minimum MCU resources to start user application code.

9.2 Features

- Initial MCU core MMU setup with minimum address translation for all internal MCU resources
- MMU configuration to boot user application, compiled as Classic PowerPC Book E code or as Freescale VLE code
- Passes control to user application code in the internal flash or external memory device
- Automatic switch to Serial Boot mode if internal or external flash is blank or invalid
- Serial boot by loading user program via CAN bus or eSCI to the internal SRAM
 - User programmable 64 bit password protection
 - Optional automatic detection of the host SCI or CAN speed
- Boot from an external memory device, connected to the EBI¹
 - Option to boot from 16 bit memory device with separate data and address lines
 - Option to boot from 32/16 bit memory device with multiplexed data and address lines
- Controls MCU core Watchdog Timer and/or the Software Watchdog Timer (SWT)

9.3 Modes of Operation

9.3.1 Normal Mode

The BAM program is executed immediately following the negation of $\overline{\text{RESET}}$.

1. EBI not available on all packages.

9.3.2 Debug Mode

The BAM program is not executed when the MCU exits reset in OnCE debug mode. Before accessing the MCU resources, use the development tool to initialize the MCU.

9.3.3 Internal Boot Mode

Use this operating mode to boot from internal flash memory, which holds all of the code and configuration data.

9.3.4 Serial Boot Mode

Use this mode to load a user program into internal SRAM, using the eSCI or CAN serial interface, then to execute that program. The program can then control

- the download of data, and
- erasing and programming of the internal or external flash memory.

9.3.5 Development Bus Boot Mode

This boot mode is intended for packaged versions of the device that have the development bus pinned out. The development bus (EBI) boot mode can be used for application code development.

9.4 Memory Map

The BAM occupies 16 KB of memory space, 0xFFFF_C000 to 0xFFFF_FFFF. The actual code size of the BAM program is less than 4 KB and starts at 0xFFFF_F000, repeating itself every 4 KB in the BAM address space. The CPU starts the BAM program execution at its reset vector from address 0xFFFF_FFFC.

The BAM exits to the user code at 0xFFFF_FFF8. The last instruction the BAM executes is a BLR. The link register is pre-loaded with the user application start address. The value of the start address depends on the boot mode:

- Booting from internal or external flash — 32-bit word following a valid RCHW holds the start address value
- Serial boot — set according to the serial boot protocol

Table 9-1 shows the BAM address map.

Table 9-1. BAM Memory Map

| Address | Description |
|---------------------------|-------------------------------|
| 0xFFFF_C000 – 0xFFFF_EFFF | BAM program mirrored |
| 0xFFFF_F000 – 0xFFFF_FFFF | BAM program |
| 0xFFFF_FFFC | MCU reset vector |
| 0xFFFF_FFF8 | BAM last executed instruction |

9.5 Functional Description

9.5.1 BAM Program Flow Chart

Figure 9-1 shows the BAM program flow.

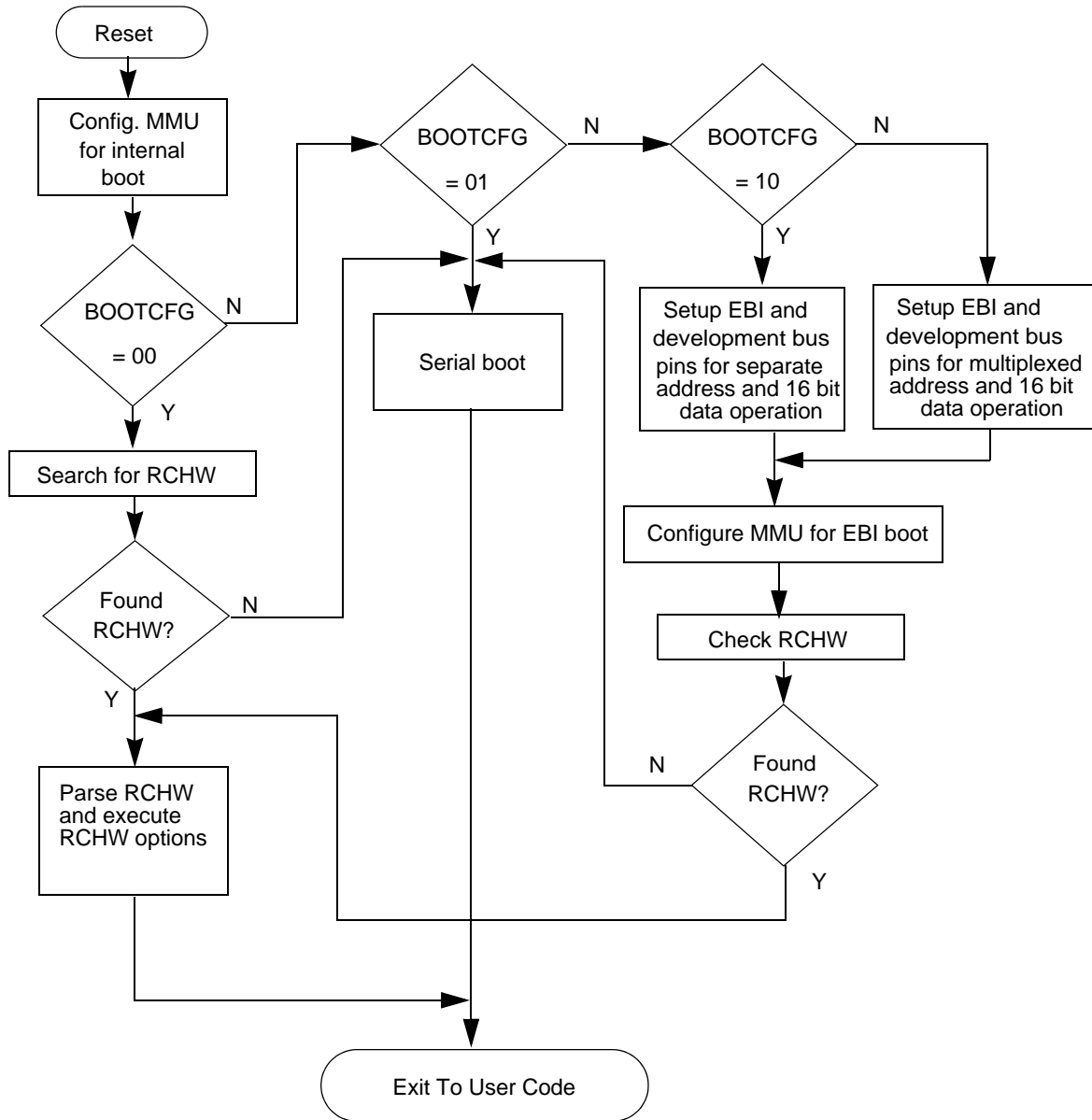

Figure 9-1. BAM program Flow Chart

9.5.2 BAM Program Operation

After negation of $\overline{\text{RESET}}$, the MCU core accesses the BAM before user code starts. First, the BAM program configures the core MMU to allow access to all MCU internal resources, according to [Table 9-2](#). This MMU setup remains untouched through internal flash boot mode.

Table 9-2. MMU Configuration for Internal Flash Boot

| TLB Entry | Region | Logical Base Address | Physical Base Address | Size | Attributes |
|-----------|-----------------------------|----------------------|-----------------------|--------|--|
| 0 | Peripheral Bridge B and BAM | 0xFFFF0_0000 | 0xFFFF0_0000 | 1 MB | Guarded Big endian Global PID Cache Inhibit |
| 1 | Internal Flash | 0x0000_0000 | 0x0000_0000 | 16 MB | Not guarded Big endian Global PID |
| 2 | EBI | 0x2000_0000 | 0x0000_0000 | 16 MB | Not guarded Big endian Global PID |
| 3 | Internal SRAM | 0x4000_0000 | 0x4000_0000 | 256 KB | Not guarded Big endian Global PID Cache Inhibit |
| 4 | Peripheral Bridge A | 0xC3F0_0000 | 0xC3F0_0000 | 1 MB | Guarded Big endian Global PID Cache Inhibit |

The MMU regions are mapped with logical addresses the same as physical addresses except for the external bus interface (EBI). The logical EBI address space is mapped to physical address space of the internal flash memory. This allows code, written to run from external memory, to execute from internal flash.

After the MMU configuration, the BAM program starts the boot sequence depending on the SIU_RSR[BOOTCFG] value, as shown in [Table 9-3](#).

Depending on the values stored in the censorship word and serial boot control word in the shadow row of the internal flash memory, the internal flash memory can be enabled or disabled, the Nexus port can be enabled or disabled, the password received in the serial boot mode is compared with the fixed public password or compared to a user programmable password in the internal flash memory.

Table 9-3. Boot Modes

| Boot Mode Name | BOOTCFG[1:0] | Censorship Control 0x00FF_FDE0 | Serial Boot Control 0x00FF_FDE2 | Internal Flash State | Nexus State | Serial Password |
|---|--------------|-----------------------------------|------------------------------------|----------------------|-------------|-----------------|
| Internal - Censored | 00 | any value except 0x55AA | Don't care | Enabled | Disabled | Flash |
| Internal - Public | | 0x55AA | | Enabled | Enabled | Public |
| Serial - Flash Password | 01 | Don't care | 0x55AA | Enabled | Disabled | Flash |
| Serial - Public Password | | | Any value except 0x55AA | Disabled | Enabled | Public |
| Development Bus separate address and data, flash is censored | 10 | 0x55AA | Don't care | Enabled | Enabled | Public |
| Development Bus separate address and data, flash is NOT censored | | Any value except 0x55AA | | Disabled | | |
| Development Bus multiplexed address and data, flash is censored | 11 | 0x55AA | Don't care | Enabled | Enabled | |
| Development Bus multiplexed address and data, flash is NOT censored | | Any value except 0x55AA | | Disabled | | |

The censorship word is a 32 bit word of data stored in the shadow row of internal flash memory. This memory location is read by hardware as part of the boot process and is used in conjunction with the BOOTCFG pins to enable and disable the internal flash memory and the Nexus interface. The censorship word consists of two fields: censorship control and serial boot control. The censorship word is programmed during manufacturing to be 0x55AA_55AA. This results in a device that is not censored and uses a flash-based password for serial boot mode.

Address: 0x00FF_FDE0

Value: 0x55AA

| | | | | | | | | | | | | | | | | |
|--------------|---|---|---|---|---|---|---|---|---|---|----|----|----|----|----|----|
| | 0 | 1 | 2 | 3 | 4 | 5 | 6 | 7 | 8 | 9 | 10 | 11 | 12 | 13 | 14 | 15 |
| Binary value | 0 | 1 | 0 | 1 | 0 | 1 | 0 | 1 | 1 | 0 | 1 | 0 | 1 | 0 | 1 | 0 |
| Hex value | 5 | | | | 5 | | | | A | | | | A | | | |

Censorship control field—default value configures the device as uncensored.

Address: 0x00FF_FDE2

Value: 0x55AA

| | | | | | | | | | | | | | | | | |
|--------------|---|---|---|---|---|---|---|---|---|---|----|----|----|----|----|----|
| | 0 | 1 | 2 | 3 | 4 | 5 | 6 | 7 | 8 | 9 | 10 | 11 | 12 | 13 | 14 | 15 |
| Binary value | 0 | 1 | 0 | 1 | 0 | 1 | 0 | 1 | 1 | 0 | 1 | 0 | 1 | 0 | 1 | 0 |
| Hex value | 5 | | | | 5 | | | | A | | | | A | | | |

Serial boot control field—default value reads a password from internal flash.

Figure 9-2. Censorship Word

The BAM program uses SIU_CCR[DISNEX], which reflects the Nexus module state, to determine if the serial password received in serial boot mode should be compared to:

- Public password (0xFEED_FACE_CAFE_BEEF) if DISNEX is cleared
- Flash password (64-bit value, stored in the shadow block of internal flash at address 0x00FF_FDD8) if DISNEX is set

NOTE

Regardless of the boot mode used, program a valid serial password. This allows you to rescue the device using serial boot mode if the flash content is corrupted.

Flash Password@ 0x00FF_FDD8 – 0x00FF_FDDF

| | | | | | | | | | | | | | | | |
|---|---|---|---|---|---|---|---|---|---|----|----|----|----|----|----|
| 0 | 1 | 2 | 3 | 4 | 5 | 6 | 7 | 8 | 9 | 10 | 11 | 12 | 13 | 14 | 15 |
| 1 | 1 | 1 | 1 | 1 | 1 | 1 | 0 | 1 | 1 | 1 | 0 | 1 | 1 | 0 | 1 |
| Serial Boot Password (0x00FF_FDD8) - 0xFEED (Factory Default) | | | | | | | | | | | | | | | |

| | | | | | | | | | | | | | | | |
|---|----|----|----|----|----|----|----|----|----|----|----|----|----|----|----|
| 16 | 17 | 18 | 19 | 20 | 21 | 22 | 23 | 24 | 25 | 26 | 27 | 28 | 29 | 30 | 31 |
| 1 | 1 | 1 | 1 | 1 | 0 | 1 | 0 | 1 | 1 | 0 | 0 | 1 | 1 | 1 | 0 |
| Serial Boot Password (0x00FF_FDDA) - 0xFACE (Factory Default) | | | | | | | | | | | | | | | |

| | | | | | | | | | | | | | | | |
|---|----|----|----|----|----|----|----|----|----|----|----|----|----|----|----|
| 32 | 33 | 34 | 35 | 36 | 37 | 38 | 39 | 40 | 41 | 42 | 43 | 44 | 45 | 46 | 47 |
| 1 | 1 | 0 | 0 | 1 | 0 | 1 | 0 | 1 | 1 | 1 | 1 | 1 | 1 | 1 | 0 |
| Serial Boot Password (0x00FF_FDDC) - 0xCAFE (Factory Default) | | | | | | | | | | | | | | | |

| | | | | | | | | | | | | | | | |
|---|----|----|----|----|----|----|----|----|----|----|----|----|----|----|----|
| 48 | 49 | 50 | 51 | 52 | 53 | 54 | 55 | 56 | 57 | 58 | 59 | 60 | 61 | 62 | 63 |
| 1 | 0 | 1 | 1 | 1 | 1 | 1 | 0 | 1 | 1 | 1 | 0 | 1 | 1 | 1 | 1 |
| Serial Boot Password (0x00FF_FDDE) - 0xBEEF (Factory Default) | | | | | | | | | | | | | | | |

Figure 9-3. Serial Boot Flash Password

9.5.3 Reset Configuration Half Word (RCHW)

The Reset Configuration Half Word defines boot options and must be programmed to predefined locations in the internal flash or at the beginning of the external flash device. The 32 bit word after the RCHW must be programmed with the user application’s starting address. The BAM passes control to the user application at this starting address.

Table 9-6 provides possible RCHW locations in the internal flash. When booting from the external flash device, the RCHW must reside in the first 16 bit half word of the flash.

BOOT_BLOCK_ADDRESS

| | | | | | | | | | | | | | | | |
|------------------------|---|---|---|-----|-----|-----|-----|---|---|----|----|----|----|----|----|
| 0 | 1 | 2 | 3 | 4 | 5 | 6 | 7 | 8 | 9 | 10 | 11 | 12 | 13 | 14 | 15 |
| | | | | SWT | WTE | PS0 | VLE | 0 | 1 | 0 | 1 | 1 | 0 | 1 | 0 |
| Boot Identifier = 0x5A | | | | | | | | | | | | | | | |

Figure 9-4. Reset Configuration Half Word

Table 9-4. RCHW Field Descriptions

| Field | Description |
|----------------|---|
| 0–3 | Reserved. These bit values are ignored when the halfword is read. Program to 0 for future compatibility. |
| 4 SWT | Software watchdog timer enable. This bit determines if the software watchdog timer is enabled after passing control to the user application code. 0 Disable software watchdog timer 1 Enable software watchdog timer after reset. The timeout period is 392400 clock cycles (the default SWT clock is the crystal oscillator). |
| 5 WTE | MCU core watchdog timer enable. This bit determines if the core software watchdog timer is enabled after passing control to the user application code. 0 Disable core software watchdog timer 1 Enable core watchdog timer after reset. The timeout period is 2.5×2^{17} system clocks. |
| 6 PS0 | Port size. Defines the width of the data bus connected to the memory on D_CS0. After system reset, the BAM changes D_CS0 to a 16-bit port to fetch the RCHW from either 16- or 32-bit external memories. Then the BAM reconfigures the EBI as a 16- or 32-bit port, depending on this bit. 0 32-bit D_CS0 port size 1 16-bit D_CS0 port size Note: Used in development bus boot modes only (not available on all packages). Do not clear this bit if the device only has a 16-bit data bus. |
| 7 VLE | VLE Code Indicator. This bit configures the MMU entries 1-3 coded as Classic Book E instructions or as Freescale VLE instructions. 0 User code executes as classic Book E code 1 User code executes as Freescale VLE code |
| 8–15 BOOTID | Boot identifier. This field serves two functions: <ul style="list-style-type: none"> Indicates which block in flash memory contains the boot program Indicates if the flash memory is programmed (BOOTID=0x5A) or invalid |

When enabled by RCHW[SWT, WTE] bits, the watchdog timeout periods are as shown in the [Table 9-5](#). Note the following:

- The core WD timeout for 20 and 40 MHz crystal is the same because the PLLCFG[2] pin should be set for 40 MHz crystal, which has the effect of doubling the PLL input divider.
- The SWT clock source is directly from the crystal oscillator. The core WD is clocked by the PLL.
- The core WD timeouts reported here correspond to the PLL settings after reset. Core WD timeouts will change as soon as the PLL is programmed with different multipliers.

Table 9-5. Watchdog Timeout vs. Crystal Frequency¹

| Crystal Frequency (MHz) | Core WD Timeout (ms) | SWT Timeout (ms) |
|-------------------------|----------------------|------------------|
| 8 | 27.3 | 49 |
| 12 | 18.3 | 32.7 |
| 16 | 13.7 | 24.5 |
| 20 | 11 | 19.6 |
| 40 | | 9.8 |

¹ With the PLL in normal mode and crystal oscillator as a reference clock source.

9.5.3.1 Application Start Address Register

Application Start Address Register (Figure 9-5) is the 32-bit word after the RCHW in the application code memory device (internal or external flash). The BAM uses the value from this location as a start address of the user application to pass control to.

BOOT_BLOCK_ADDRESS + 0x0000_0004

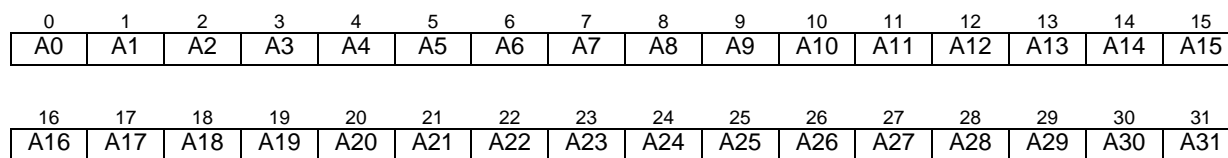

Figure 9-5. Application Start Address Register

9.5.4 Internal Boot Mode

When the BAM program detects internal flash boot mode, the BAM:

1. Configures a machine check exception handler, since it will be accessing flash memory locations that may be corrupted and cause a bus error
2. Searches for a valid RCHW in six pre-defined locations, as shown in Table 9-6

Table 9-6. Possible RCHW Locations in the Internal Flash

| Block | Address |
|-------|-------------|
| 0 | 0x0000_0000 |
| 1 | 0x0000_4000 |
| 2 | 0x0001_0000 |
| 3 | 0x0001_C000 |
| 4 | 0x0002_0000 |
| 5 | 0x0003_0000 |

3. If a valid RCHW is not found, the BAM program switches to serial boot mode
4. If the BAM program finds a valid RCHW:
 - BOOT_BLOCK_ADDRESS is the address (from Table 9-6) of the valid RCHW
 - The BAM program fetches the application start address from BOOT_BLOCK_ADDRESS + 0x4
 - The BAM branches to this start address (shown in Figure 9-5)
 - The core watchdog is enabled (if RCHW[WTE] = 1) and/or SWT is disabled (if RCHW[SWT] = 0)
 - The MMU TLB entries 1,2,3 are programmed with VLE attribute if the RCHW[VLE] = 1.

9.5.5 Serial Boot Mode

When serial boot mode is detected, either because of the BOOTCFG configuration or because a valid RCHW word was not found in any of the expected locations in the Flash, the BAM program does the following:

- Uses message buffers in CAN_A for program stack and variables
- Polls the FMPLL_SYNCR[LOCK] bit until it indicates that the PLL has locked
- Switches the system clock source to the PLL, by setting SIU_SYSDIV[SYSCLKSEL] = 0x2
- Disables the core watchdog timer and sets the SWT timeout period to 2.5×2^{27} cycles
- Waits for the host to send a 64-bit password by either the CAN or SCI
- Receives start address, size of download code in bytes, and VLE bit
- Receives the application code data
- Disables the SWT and enables the core watchdog timer with a timeout period of 2.5×2^{27} systemclock cycles
- Branches to the loaded code at the start address

The MMU setup depends on how the BAM entered the serial boot mode. If it attempted to boot from the development bus but switched to serial boot because it could not find a valid RCHW in Flash, the MMU is set up as for that mode (see [Table 9-11](#)). Otherwise the MMU setup matches the [Table 9-2](#).

The serial boot mode can run in two modes, depending on the state of the EVTO pin during reset (the SIU_RSR[ABR] bit reflects the inverted state of the EVTO pin):

- Standard serial boot mode — fixed baud rates derived from the MCU system frequency. EVTO pin is kept high during reset.
- Baud Rate Detection serial boot mode — allows communication with adaptable speed, based on measured baud rate of the host transmission. EVTO pin has to be driven low for this mode.

The EVTO pin is pulled up by an internal pull-up. Actively driven low EVTO pin selects the Baud Rate Detection mode.

When the Fixed Baud Rate mode is selected, the BAM program configures the RXD_A pin to be the input of the eSCI_A module, CNRX_A pin as an input, and CNTX_A as an output of the CAN_A module. When Baud Rate Detection mode is selected, the BAM program configures RXD_A and CNRX_A pins as GPI inputs for polling their state by the CPU.

The SCI and CAN controllers pins configuration summary is shown in the [Table 9-7](#).

Table 9-7. CAN/eSCI Pins Configuration for CAN/eSCI Fixed Baud Rate Boot Modes

| Pins | Reset Function | Initial Serial Boot Mode | | Serial Boot Mode after a valid CAN message received | | Serial Boot Mode after a valid eSCI message received | |
|--------|----------------|--------------------------|---|---|---|--|---|
| | | Function | Pad Configuration | Function | Pad Configuration | Function | Pad Configuration |
| CNTX_A | GPIO | CNTX_A | Push/Pull output, with medium slew rate | CNTX_A | Push/Pull output, with medium slew rate | GPIO | — |
| CNRX_A | GPIO | CNRX_A | Input with pull-up and hysteresis | CNRX_A | Input with pull-up and hysteresis | GPIO | — |
| TXD_A | GPIO | GPIO | — | GPIO | — | TXD_A | Push/Pull output, with medium slew rate |
| RXD_A | GPIO | RXD_A | Input with pull-up and hysteresis | GPIO | — | RXD_A | Input with pull-up and hysteresis |

The BAM configures the communication modules for reception with fixed baud rates as shown in the [Table 9-8](#) and waits for data reception.

Table 9-8. Serial Boot Mode — Baud Rate and Watchdog Summary¹

| Crystal Frequency (MHz) | System Clock Frequency (MHz) | Desired Baud Rate (baud) | Actual eSCI Baud Rate (baud) | CAN Baud Rate (baud) | Core Watchdog Timeout period ² (s) | SWT Timeout period during serial boot ³ (s) |
|-------------------------|------------------------------|--------------------------|------------------------------|----------------------|---|--|
| f_{xtal} | $f_{sys} = 1.5 * f_{xtal}$ | — | $f_{sys} / 1248$ | $f_{sys} / 60$ | $2.5 * 2^{27} / f_{sys}$ | $2.5 * 2^{27} / f_{xtal}$ |
| 8 | 12 | 9600 | 9615 | 200k | 27.96 | 41.9 |
| 12 | 18 | 14400 | 14423 | 300k | 18.64 | 28 |
| 16 | 24 | 19200 | 19230 | 400k | 13.98 | 21 |
| 20 | 30 | 24000 | 24038 | 500k | 11.18 | 16.8 |
| 40 | 60 | 48000 | 48077 | 1000k | | 8.4 |

¹ With the PLL in normal mode and crystal oscillator as a reference clock source.

² The core WD is disabled during serial boot and is then enabled after serial boot finishes (with timeouts indicated here)

³ The SWT is enabled during serial boot, but disabled after serial boot finishes.

If a message containing 8 bytes with ID 0x11 is received by the CAN controller first, the BAM program:

- Transitions to serial CAN boot mode
- Disables the eSCI
- Configures RXD_A to its reset state
- Transitions to the CAN serial download protocol routine

If a byte from eSCI is received first, the BAM program:

- Transitions to the Serial SCI Boot sub-mode
- Disables CAN_A module
- Configures CAN_A's pins to their reset state
- Transitions to the SCI serial download protocol routine

9.5.5.1 CAN Controller Configuration in the Fixed Baud Rate Mode

The CAN controller is configured to operate at a baud rate equal to system frequency divided by 60, using the standard 11 bit identifier format detailed in CAN 2.0A specification. See [Table 9-8](#) for examples of baud rates. Only one message buffer 0 is used for all communications.

The bit timing is configured as shown in [Figure 9-6](#).

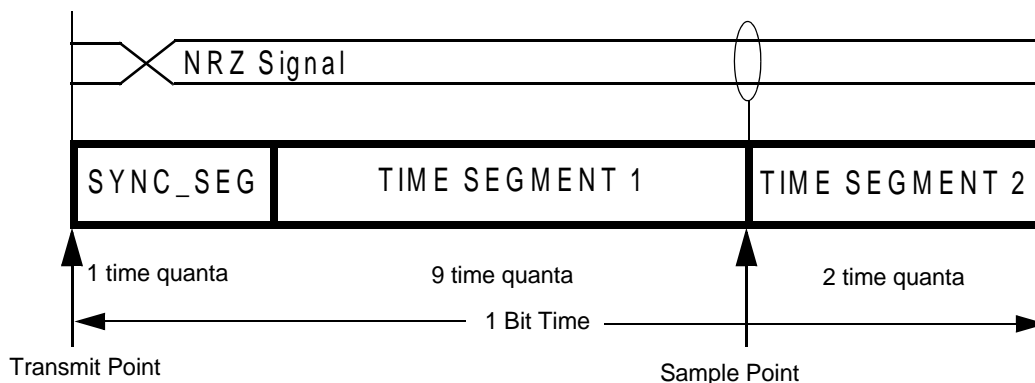

Note: 1 Time quanta = 5 System clock periods

Figure 9-6. CAN Bit timing

The BAM program ignores CAN errors and all received messages are assumed to be good. Received messages are transmitted back. The host processor must compare the MCU transmissions with the sent data and restart the process if an error is detected.

9.5.5.2 SCI Controller Configuration in Fixed Baud Rate Mode

The eSCI is configured for 1 start bit, 8 data bits, no parity, 1 stop bit and operates at a baud rate equal to system clock divided by 1248. See [Table 9-8](#) for examples of baud rates.

The BAM program ignores the eSCI errors: All data received is assumed to be good and is sent back through the TXD pin. The host processor must compare the MCU transmitted data with the sent data and restart the process if an error is detected.

9.5.5.3 Serial Boot Mode Download Protocol

The download protocol follows four steps:

1. Host sends 64-bit password.
2. Host sends start address, size of download code in bytes, and VLE bit.
3. Host sends the application code data.
4. The MCU switches to the loaded code at the start address.

The communication is done in half-duplex manner; any transmission from host is followed by the MCU transmission. The host computer should not send data until it receives echo from the MCU. All multi byte data structures must be sent most-significant byte (MSB) first.

When the CAN is used for serial download, the data is packed into standard CAN messages in the following manner:

- A message with 0x11 ID and 8-byte length to send the password. The MCU transmits back the same data, but with ID of 0x1.
- A message with 0x12 ID and 8-byte length to send the start address, length, and the VLE mode bit. The MCU transmits back the same data, but with ID of 0x2.

- Messages with 0x13 ID are used to send the downloaded data. The MCU transmits back the same data with ID of 0x3.

When the SCI is used for serial download, the data must be sent on a byte-by-byte basis. The MCU transmits back the received bytes.

Since the MCU has to initialize itself to execute the serial boot there is a dead time from MCU $\overline{\text{RSTOUT}}$ negation when the host should wait before sending first data frame. This time should be more than 5000 system clock periods.

9.5.5.4 Download Protocol Execution

The BAM program executes the serial boot as following:

1. Download 64-bit password.
 - a) The received 8-byte password is checked for validity. For a password to be valid, none of its four 16-bit half words must equal 0x0000 or 0xFFFF.
 - b) The BAM program then checks the censorship status of the MCU. If SIU_CCR[DISNEX] is set, the MCU is considered to be censored and the password is compared with a password stored in the shadow row in internal flash memory.
 - c) If SIU_CCR[DISNEX] is cleared, the MCU is not considered to be censored and the password is compared to the fixed value of 0xFEED_FACE_CAFE_BEEF.
 - d) If the password check fails, the MCU stops responding. Assert $\overline{\text{RESET}}$ to force the MCU out of this state.
 - e) If the password check passes, the BAM transitions to the next step in the protocol.
2. Download start address, size of download, and VLE bit.

The BAM considers the next 8 bytes to contain a 32-bit start address, the VLE mode bit, and a 31-bit code length (see [Figure 9-7](#)).

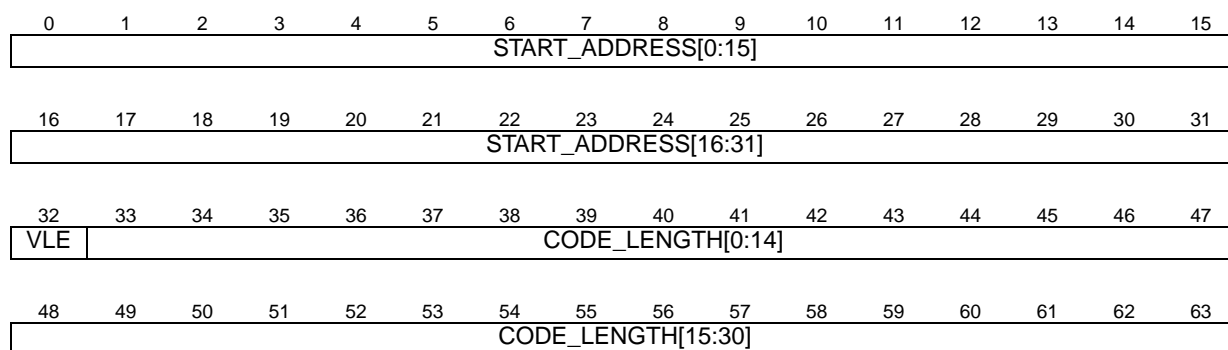

Figure 9-7. Start Address, VLE Bit and Download Size in Bytes

- START_ADDRESS defines where the received data is stored and where the MCU branches after the download is finished. The two least significant bits of the start address are ignored by the BAM program, thus the loaded code should be 32-bit word aligned.
- CODE_LENGTH defines how many data bytes to be loaded.

- VLE instructs the MCU to program MMU entries 1–3 with VLE attribute. If it is 1, the downloaded code must be compiled to VLE instructions, if it is 0 the code contains classic Power Book E architecture instructions.

3. Download data.

Each byte of data received is stored in the MCU memory, starting at the `START_ADDRESS` specified in the previous step. The data increments through memory until the number of bytes stored matches `CODE_LENGTH` specified in the previous step.

The BAM program buffers incoming data, collecting up to eight bytes. The buffered data is written to the RAM with 64-bit writes to prevent ECC errors, which may happen if the MCU RAM is protected by 64-bit ECC code.

Once the buffered data is written to the RAM the BAM program refreshes the SWT.

NOTE

Only system RAM supports 64-bit writes; therefore, attempting to download data to other RAM apart from system RAM causes errors.

If the start address of the downloaded data is not on an 8-byte boundary, the BAM writes 0x0 to the memory locations from the preceding 8-byte boundary to the start address (maximum 4 bytes). The BAM also writes 0x0 to all memory locations from the last byte of data downloaded to the following 8 byte boundary (maximum 7 bytes). An additional 8 zero bytes are written to prevent possible ECC errors that may be caused by the CPU pre-fetching.

The BAM appends an additional two zero double-words at the end of the code loaded into system RAM in order to prevent possible ECC errors, which could otherwise happen due to the CPU pre-fetching data after the last instruction where the RAM is not initialized.

The last loaded code address must not equal or exceed 0x4003_FFF0 (the highest RAM address allowed by MMU settings minus the two zero double-words, written by BAM at the end of code download).

4. Switch to the loaded code.

The BAM program waits for the last echo message transmission to complete, then the active communication controller is disabled. Its pins revert to GPIO inputs.

To provide compatibility with older devices, the BAM

- writes the core's time base registers (TBU and TBL) with 0x0
- enables the core watchdog to cause a reset after a time-out period of 2.5×2^{27} system clock cycles
- disables software watchdog (SWT)

See [Table 9-8](#) for examples of time out periods.

The BAM code passes control to the loaded code at `START_ADDRESS`, which was received in step 2 of the protocol.

NOTE

The loaded code must periodically refresh the core watchdog timer or change the timeout period to a value that does not cause resets during normal operation.

9.5.5.5 Baud Rate Detection Procedure

When EVTO pin is driven low during reset, the BAM program enters into Baud Rate Detection mode.

Following additional steps are taken:

1. The baud rate detection routine is copied to the beginning of the system RAM from the BAM ROM to improve baud rate detection accuracy
2. The CPU branches to the RAM
3. The MCU configures the CNRX_A and RXD_A pins as general purpose inputs
4. The MCU polls these GPIs until one of them goes low
 - a) If the CNRX_A pin transitions first, the BAM program starts CAN baud rate detection routine, ignoring RXD_A. After detecting the CAN baud rate, the BAM program transitions to the CAN download protocol routine described above.
 - b) If the RXD_A pin transitions first, the SCI baud rate detection and download protocol routines are called, ignoring any further CAN pins activity.

The host, executing the serial boot, should send a test frame in order the MCU can detect the host communication speed. When booting through the SCI, the host should send a zero byte as the test frame. When booting through the CAN, the host should send zero ID, zero length message as the test frame.

The MCU requires some time to setup its communication interfaces speed. To accommodate this the host should send serial password not earlier than after 2000 MCU system clock periods.

9.5.5.5.1 SCI Baud Rate Detection.

The host must send a zero byte to allow the MCU to detect the serial link baud rate. The host transmits one start bit, eight zero data bits and one stop bit (the MCU does not echo it).

The MCU polls the RXD_A pin for high to low transition and starts the e200 core Time Base counter (TB). Then the MCU polls for low to high transition on the pin and when it happens, the MCU turns off the TB counter. The TB content is used to calculate incoming signal baud-rate. The SCI baud rate is equal to the TB content divided by 288. (Measured over 9 bits with 16 system clocks per bit and the core frequency is two times higher than system frequency).

9.5.5.6 CAN Baud Rate Detection.

The host transmits a zero length message with zero 11 bit ID and MCU measures time over 40 bits, polling CNRX_A pin for high and low, according to the sent data. The MCU does not acknowledges this message.

The CAN baud rate depends on the number of quantas per bit and serial clock frequency, which is defined by a prescaler. The CAN baud rate detection routine selects these parameters to maximize number of

quantas per bit and achieve minimum difference between measured value and duration of the 40 CAN bits, to be programmed with selected pair of the parameters.

The CAN controller can be programmed with 8 to 25 number of quantas per bit. The bit timing parameters, can be selected by the baud rate detection routine, are shown in the [Table 9-9](#). See the parameters descriptions in the FlexCAN block guide)

Table 9-9. Lookup Table for CAN Bit Timing.

| Time quanta per bit | Time segment 1 | | Time Segment 2 | RJW |
|---------------------|----------------|-------|----------------|-----|
| | PROPSEG | PSEG1 | PSEG2 | |
| 8 | 1 | 3 | 3 | 2 |
| 9 | 2 | 3 | 3 | 2 |
| 10 | 3 | 3 | 3 | 2 |
| 11 | 4 | 3 | 3 | 2 |
| 12 | 3 | 4 | 4 | 2 |
| 13 | 4 | 4 | 4 | 3 |
| 14 | 5 | 4 | 4 | 3 |
| 15 | 6 | 4 | 4 | 4 |
| 16 | 7 | 4 | 4 | 3 |
| 17 | 8 | 4 | 4 | 3 |
| 18 | 7 | 5 | 5 | 4 |
| 19 | 8 | 5 | 5 | 4 |
| 20 | 7 | 6 | 6 | 4 |
| 21 | 8 | 6 | 6 | 4 |
| 22 | 7 | 6 | 6 | 4 |
| 23 | 8 | 6 | 6 | 4 |
| 24 | 7 | 7 | 7 | 4 |
| 25 | 8 | 7 | 7 | 4 |

Maximum and minimum speeds of the serial communication modules are defined by the MCU system frequency and shown in the [Table 9-10](#).

Table 9-10. Maximum and Minimum Detectable Baud Rates¹

| F_{xtal} (MHz) | $F_{sys} =$ $1.5 * F_{xtal}$ (MHz) | Max Baud rate for CAN ($F_{sys}/9$) ² (bps) | Min CAN Baud rate ($F_{sys}/25/256$) bps | Max Baud rate for SCI ($F_{sys}/160$)(bps) | Min Baud rate for SCI ($F_{sys}/16/2^{16}$)(bps) |
|---------------------|--|---|---|---|---|
| 8 | 12 | 1M | 1875 | 75K | 11.5 |
| 12 | 18 | | 2812.5 | 112.5K | 17.2 |
| 16 | 24 | | 3750 | 150K | 23 |
| 20 | 30 | | 4687.5 | 187.5K | 28.6 |
| 40 | | | | | |

¹ When the MCU operates with the PLL in normal mode with crystal oscillator as a reference clock source.

² Limited by 1Mbps by CAN standard

9.5.6 Booting from the Development Bus

If the MCU boots in one of the Development Bus boot modes, the BAM program:

- Reprograms the MMU entries for EBI and internal flash (see [Table 9-11](#))
- Sets up the EBI and development bus pins
- Tries to read RCHW from logical address 0x2000_0000

If the valid RCHW is read from that address, the BAM program:

- Reads the user application code start address from 0x2000_0004 address
- Parses RCHW
- Sets up watchdogs
- Updates EBI, SRAM and internal flash MMU entries(1-3), according to RCHW[VLE]
- Passes control to the user code

If no valid RCHW was read, BAM switches to the serial boot mode.

Table 9-11. MMU Configuration for Development Bus Boot modes

| TLB Entry | Region | Logical Base Address | Physical Base Address | Size | Attributes |
|-----------|----------------|----------------------|-----------------------|-------|---|
| 1 | Internal Flash | 0x0000_0000 | 0x2000_0000 | 16 MB | Not guarded Big endian Global PID |
| 2 | EBI | 0x2000_0000 | 0x2000_0000 | 16 MB | Not guarded Big endian Global PID |

9.5.6.1 EBI Configuration for Separate Address and Data Development Bus Boot Mode

The BAM program sets up EBI related registers as shown in the [Table 9-12](#).

Table 9-12. Development Bus/EBI Register Settings for Separate Address Data lines mode

| Register | Function | Value | Comments |
|---------------------------|----------------------------------|-------------|--|
| EBI_CAL_BR0 | — | 0x2000_0803 | Sets the base address to 0x2000_0000, 16-bit wide bus, burst Inhibit |
| EBI_CAL_OR0 | — | 0xFF80_00F0 | Set 15 wait states, 8MB |
| SIU_PCR259– SIU_PCR293 | D_ADD[12:30], D_ADD_DAT[0:15] | 0x0440 | Set pads to 20pf drive strength |
| SIU_PCR305– SIU_PCR307 | D_ADD[9:11] | | |
| SIU_PCR256 | D_CS0 | 0x443 | Set pads to 20pf drive strength and pull-up enable |
| SIU_PCR295 | D_WE0 | | |
| SIU_PCR297 | D_OE | | |
| SIU_PCR298 | D_TS | | |

RCHW[PS0] must be programmed to “1”, since the development bus does not support 32-bit port size in that sub-mode.

9.5.6.2 EBI Configuration for multiplexed Address and Data Development Bus Boot Mode

The BAM program sets up EBI related registers as shown in the [Table 9-13](#).

Table 9-13. Development Bus/EBI Register Settings multiplexed mode.

| Register | Function | Value | Comments |
|---|------------------|-------------|---|
| The following registers are programmed when RCHW[PS0] = 1 | | | |
| EBI_MCR | — | 0x0000_0806 | AD multiplexed mode, small port size use D16-31 |
| EBI_CAL_BR0 | — | 0x2000_0883 | Sets the base address to 0x2000_0000, 16-bit wide bus, AD multiplexed mode, burst Inhibit |
| EBI_CAL_OR0 | — | 0xFF80_00F0 | Set 15 wait states, 8MB |
| SIU_PCR259- SIU_PCR262 | D_ADD[12:15], | 0x440 | Set pads to 20pf drive strength |
| SIU_PCR305- SIU_PCR307 | D_ADD[9:11] | | |
| SIU_PCR263- SIU_PCR277 | D_ADD_DAT[16:30] | 0x840 | Set pads to 20pf drive strength |
| SIU_PCR257 | D_ADD_DAT[31] | | |
| SIU_PCR278- SIU_PCR293 | D_ADD_DAT[0:15] | 0x440 | Set pads to 20pf drive strength |
| SIU_PCR256 | D_CS0 | 0x443 | Set pads to 20pf drive strength and pull-up enable |
| SIU_PCR295 | D_WE0 | | |
| SIU_PCR297 | D_OE | | |
| SIU_PCR298 | D_TS | | |
| SIU_PCR299 | D_ALE | | |
| The following register is reprogrammed when RCHW[PS0] = 0 | | | |
| EBI_CAL_BR0 | — | 0x2000_0083 | Sets the base address to 0x2000_0000, 32-bit wide bus, AD multiplexed mode, burst Inhibit |

If the boot memory device is 32 bit wide, the RCHW must be programmed in two first half-words of the memory because when the MCU tries to read RCHW, the EBI is configured to use data lines 16–31 for 16-bit port accesses.

9.5.7 Enabling Debug of a Censored Device

When a device is in a censored state, the debug port (JTAG/Nexus) is disabled and only JTAG BSDL commands can be used. Access to the Nexus/JTAG clients on a censored device requires inputting the proper password into the JTAG Censorship Control Register during reset.

NOTE

When the debug port is enabled on a censored device, it is enabled only until the next reset.

[Figure 9-8](#) shows the logic that enables access to Nexus clients in a censored device using the JTAG port.

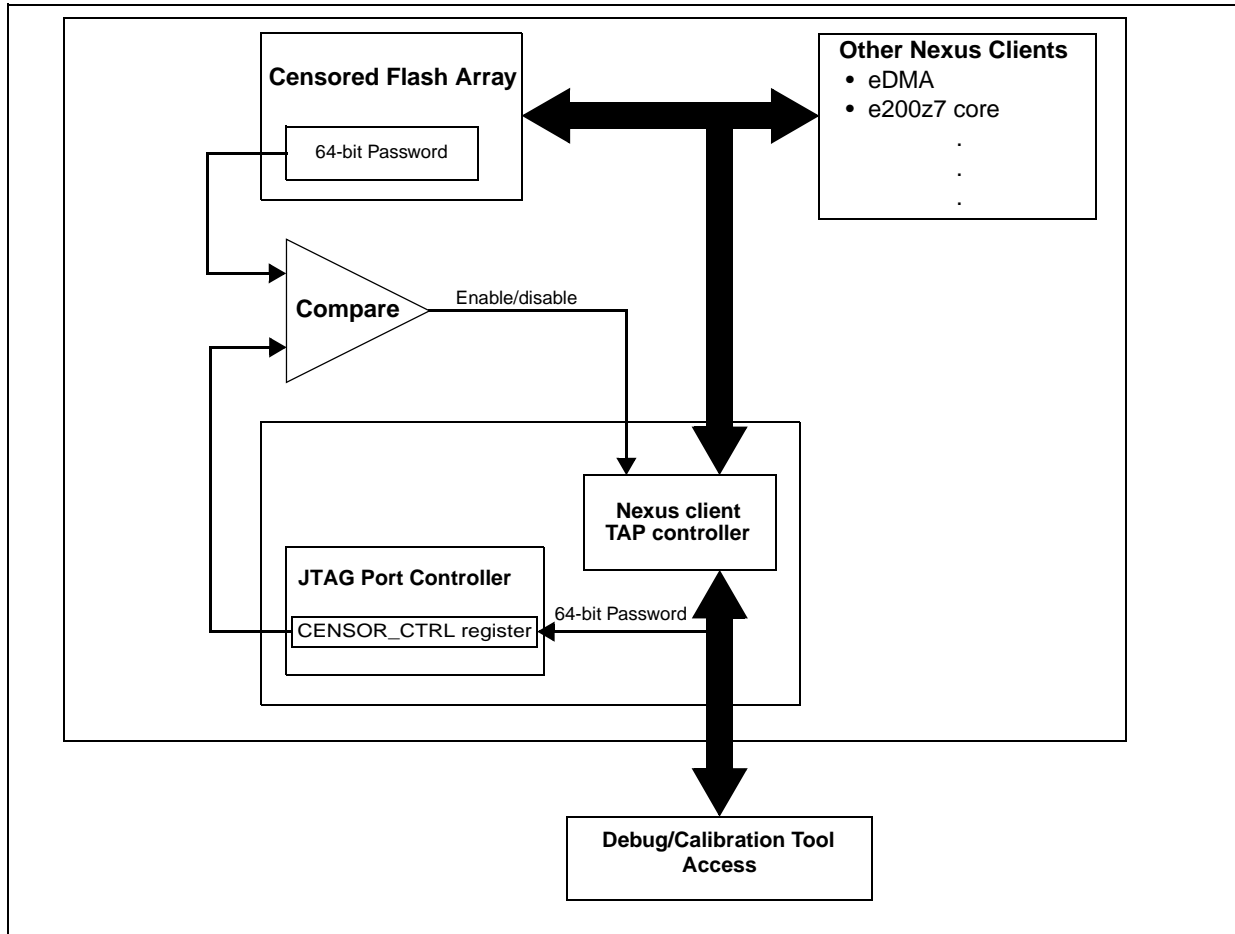

Figure 9-8. Enabling JTAG/Nexus port access on a censored device

The steps to enable the debug port on a censored device are as follows:

1. After the $\overline{\text{RSTOUT}}$ pin has is negated, hold the device in system reset state using a debugger or other tool.
2. While the device is being held in system reset state shift the 64-bit password into the CENSOR_CTRL register (see [Section 32.3.4, CENSOR_CTRL Register](#)) via the JTAG port using the JTAG ENABLE_CENSOR_CTRL instruction. The JTAG serial password is compared against the serial boot flash password from the flash shadow block.
3. If there is a match the Nexus client TAP controller enters normal operation mode and the DISNEX flag in the SIU_CCR register is negated, indicating Nexus is enabled. Upon negation of reset the debug / calibration tool is able to access the device via NEXUS port and JTAG. If the JTAG serial password does not match the serial boot flash password or the serial boot flash password is an illegal password then the debug / calibration tool is not able to access the device.

After the debug port is enabled, the tool can access the censored device and can erase and reprogram the shadow flash block in order to uncensor the device.

WARNING

If the shadow flash block is erased without reprogramming a new valid password and censorship control word before a reset occurs it will contain an illegal password and the debug port will be inaccessible. Also, if code does not exist in the first bootable region of the internal flash to reprogram the shadow flash with the proper censorship control word and password, the device will be in a censored state and may no longer be usable.

4. Subsequent resets will clear the JTAG censor password register and the Nexus client TAP controller will hold in reset again. Therefore, the tool must resend the JTAG serial password, as described above, in order to enable the Nexus client TAP controller again.



Chapter 10

Interrupts and Interrupt Controller (INTC)

10.1 Introduction

This chapter describes the interrupt controller (INTC), which schedules interrupt requests (IRQs) from software and internal peripherals to the e200z7 core. The INTC provides interrupt prioritization and preemption, interrupt masking, interrupt priority elevation, and protocol support.

Interrupts implemented by the MCU are defined in the *e200z7 Core Reference Manual*.

10.1.1 Block Diagram

Figure 4-1 shows details of the interrupt controller.

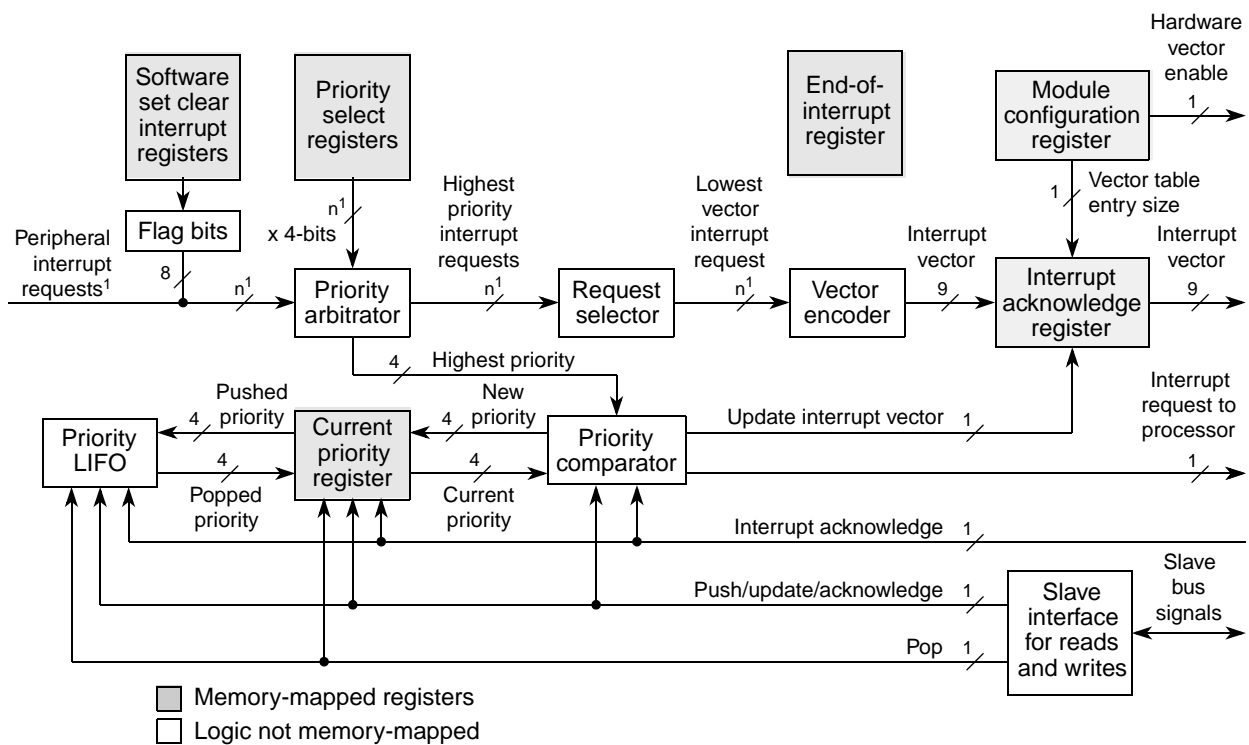

¹ Although N (largest addressable IRQ vector number) = 479, this does not indicate the total number of interrupts available on this device. The total number of available interrupts on this device is 480: 410 peripheral IRQs, 8 software-configurable IRQs, and 62 reserved.

Figure 10-1. INTC Block Diagram

10.1.2 Overview

Interrupt functionality for the device is handled between the e200z7 core and the interrupt controller. The CPU core has 19 exception sources, each of which can interrupt the core. One exception source is from the interrupt controller (INTC). The INTC provides priority-based scheduling of interrupt requests and supports programmable preemption. This scheduling scheme is suitable for statically scheduled hard real-time systems. The INTC is optimized for a large number of interrupt requests.

Table 10-1 displays the interrupt sources and the number of interrupts available for each module; Figure 10-2 shows a general diagram of INTC software vector mode.

Table 10-1. Interrupt Sources Available

| Interrupt Source (IRQs) | Number of Interrupts Available |
|-------------------------------|--------------------------------|
| Software | 8 |
| Watchdog | 1 |
| Memory | 1 |
| eDMA | 99 |
| FMPLL | 2 |
| External IRQ input pins (SIU) | 6 |
| eMIOS | 32 |
| eTPU engine A | 33 |
| eTPU engine B | 32 |
| eQADC | 62 |
| DSPI | 20 |
| eSCI | 3 |
| FlexCAN | 84 |
| FlexRay | 8 |
| STM | 2 |
| Decimation Filter | 16 |
| System (PIT, RTI, PMC, etc.) | 7 |

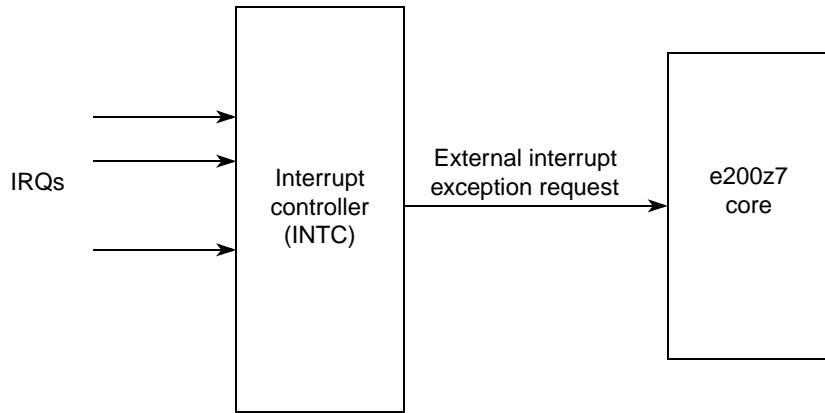

Figure 10-2. INTC Software Vector Mode

Two modes are available to determine the vector for the interrupt request source: software vector mode and hardware vector mode. In software vector mode, as shown in Figure 10-2, the e200z7 branches to a common interrupt exception handler whose location is determined by an address derived from special purpose registers IVPR and IVOR4. The interrupt exception handler reads the INTC_IACKR to determine the vector of the interrupt request source. Typical program flow for software vector mode is shown in Figure 10-3.

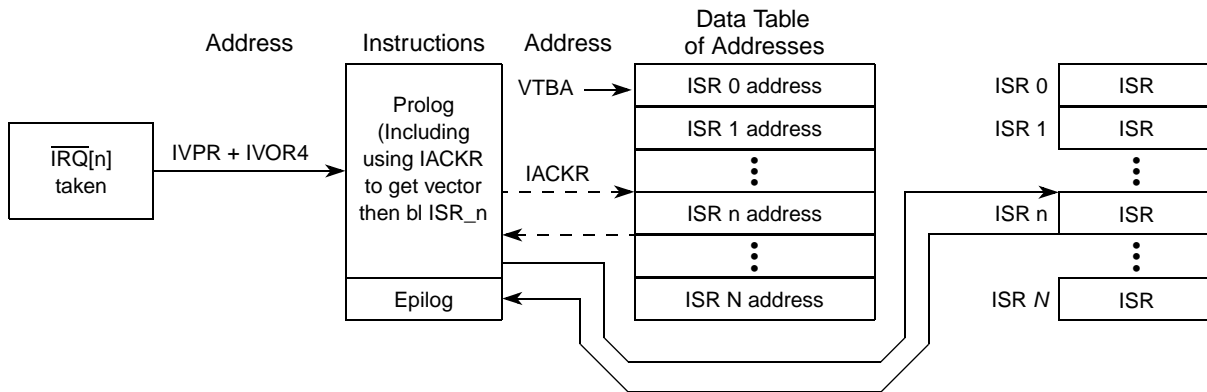

Figure 10-3. Program Flow—Software Vector Mode

N is the largest vector number (479) with the greatest hexadecimal address ($IVPR + 0x1DF0$) that is available in the interrupt memory map for this device. Because blocks of memory throughout the total memory map are used for other purposes, the maximum vector number does not indicate the total number of available interrupt sources for this device.

The total number of entries in the interrupt memory map on this device is 480: 410 peripheral IRQs, 8 software-configurable IRQs, and 62 reserved.

In hardware vector mode, the core branches to an interrupt exception handler unique for each interrupt request source. Typical program flow for hardware vector mode is shown in Figure 10-4.

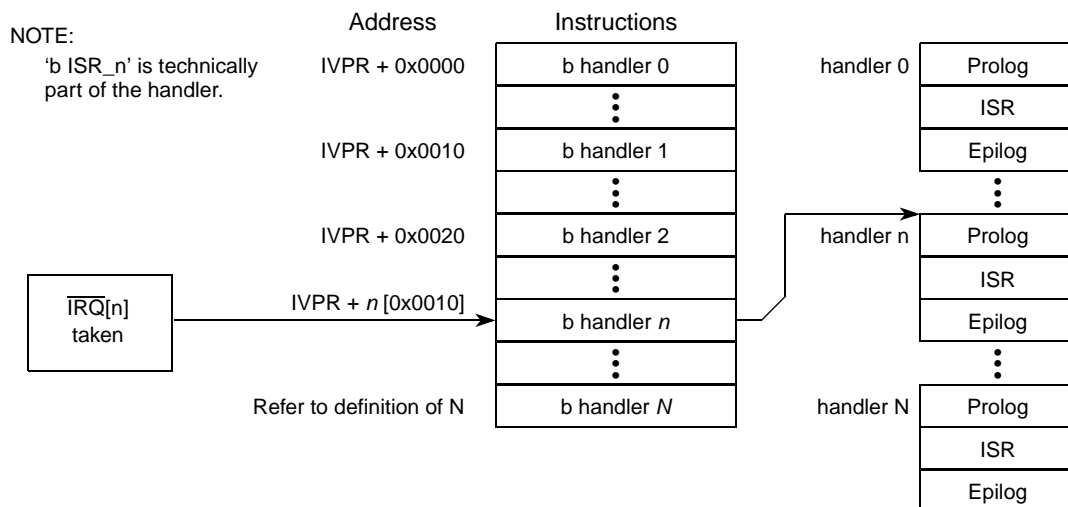

Figure 10-4. Program Flow—Hardware Vector Mode

The INTC supports a hardware vector mode that reduces the time between assertion of an interrupt and execution of the service routine. It also provides 16 priorities so that lower priority ISRs do not delay the execution of higher priority ISRs. The priority assigned to each interrupt source is programmable in the range 0 to 15, with 0 being the lowest and 15 being the highest priority.

When multiple tasks share a resource, coherent accesses to that resource need to be supported. The INTC supports the priority ceiling protocol for coherent accesses. By providing a modifiable priority mask, the priority level can be raised temporarily so that no task can preempt another task that shares the same resource.

Multiple processors can assert interrupt requests to each other through software configurable interrupt requests, i.e., by using application software to assert an interrupt request. These same software configurable interrupt requests also can be used to break the work involved in servicing an interrupt request into a high priority portion and a low priority portion. The high priority portion is initiated by a peripheral interrupt request, but then the ISR can assert a software configurable interrupt request to finish the servicing in a lower priority ISR.

10.1.3 Features

Features include the following:

- Total number of interrupt vectors is 480, of which:
 - 410 are peripheral interrupt vectors
 - 8 are software configurable sources
 - 62 are reserved sources
- 9-bit unique vector for each interrupt request source in hardware vector mode.
- Each interrupt source can be programmed to one of 16 priorities.
- Preemption.
 - Preemptive prioritized interrupt requests to processor.

- ISR at a higher priority preempts ISRs or tasks at lower priorities.
- Automatic pushing or popping of preempted priority to or from a LIFO.
- Ability to modify the ISR or task priority. Modifying the priority can be used to implement the priority ceiling protocol for accessing shared resources.
- Low latency—three clocks from receipt of interrupt request from peripheral to interrupt request to processor.

10.1.4 Modes of Operation

The interrupt controller has two handshaking modes with the processor: software vector mode and hardware vector mode. The state of the hardware vector enable bit, INTC_MCR[HVEN], determines which mode is used.

In debug mode the interrupt controller operation is identical to its normal operation of software vector mode or hardware vector mode.

10.1.4.1 Software Vector Mode

In software vector mode, there is a common interrupt exception handler address which is calculated by hardware as shown in Figure 10-5. The upper half of the interrupt vector prefix register (IVPR) is added to the offset contained in the external input interrupt vector offset register (IVOR4). Note that since bits IVOR4[28:31] are not part of the offset value, the vector offset must be located on a quad-word (16-byte) aligned location in memory.

In software vector mode, the interrupt exception handler software must read the INTC interrupt acknowledge register (INTC_IACKR) to obtain the vector number and base address of the handler associated with the corresponding peripheral or software interrupt request. The INTC_IACKR register contains a 21-bit or 20-bit address for a vector table base address (VTBA). The address is then used to branch to the corresponding routine for that peripheral or software interrupt source.

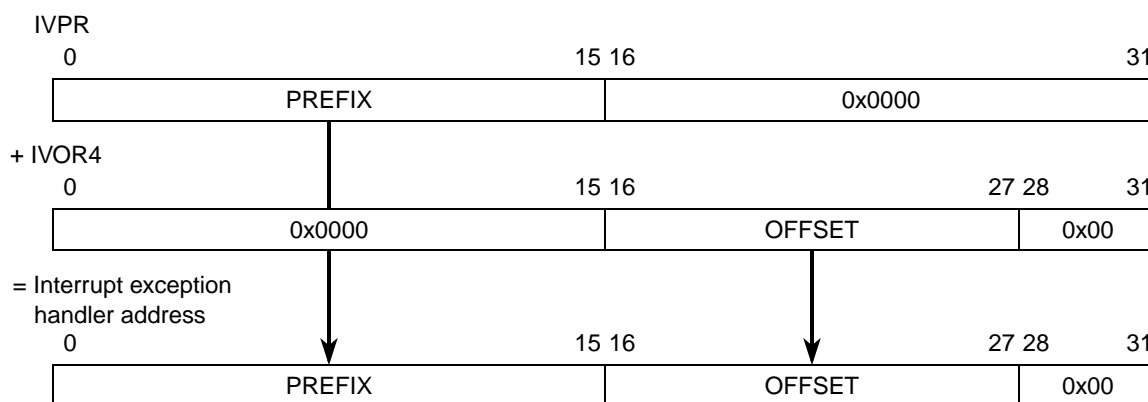

Figure 10-5. Software Vector Mode: Interrupt Exception Handler Address Calculation

Reading the INTC_IACKR acknowledges the INTC’s interrupt request and negates the interrupt request to the processor. The interrupt request to the processor does not clear if a higher priority interrupt request arrives. Even in this case, INTVEC does not update to the higher priority request until the lower priority

interrupt request is acknowledged by reading the INTC_IACKR. The reading also pushes the PRI value in the INTC current priority register (INTC_CPR) onto the LIFO and updates PRI in the INTC_CPR with the priority of the interrupt request. The INTC_CPR masks any peripheral or software configurable interrupt request at the same or lower priority of the current value of the PRI field in INTC_CPR from generating an interrupt request to the processor.

The interrupt exception handler must write to the end-of-interrupt register (INTC_EOIR) to complete the operation (assuming the source of the interrupt has been cleared). Writing to the INTC_EOIR ends the servicing of the interrupt request. The INTC's LIFO is popped into the INTC_CPR's PRI field by writing to the INTC_EOIR, and the size of a write does not affect the operation of the write. Those values and sizes written to this register neither update the INTC_EOIR contents nor affect whether the LIFO pops. For possible future compatibility, write four bytes of all 0s to the INTC_EOIR. The timing relationship between popping the LIFO and disabling recognition of external input has no restriction. The writes can happen in either order.

However, disabling recognition of the external input before popping the LIFO eases the calculation of the maximum stack depth at the cost of postponing the servicing of the next interrupt request.

10.1.4.2 Hardware Vector Mode

In hardware vector mode, the interrupt exception handler address is specific to the peripheral or software configurable interrupt source rather than being common to all of them. No IVOR is used. The interrupt exception handler address is calculated by hardware as shown in Figure 10-6. The upper half of the interrupt vector prefix register (IVPR) is added to an offset which corresponds to the peripheral or software interrupt source which caused the interrupt request. The offset matches the value in the Interrupt Vector field, INTC_IACKR[INTVEC]. Each interrupt exception handler address is aligned on a four-word (16-byte) boundary. IVOR4 is not used in this mode, and software does not need to read INTC_IACKR to get the interrupt vector number.

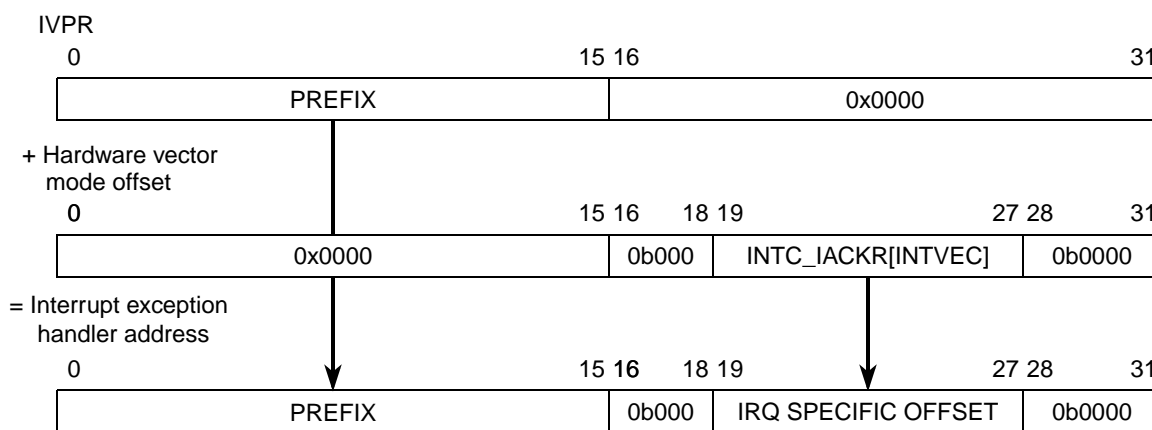

Figure 10-6. Hardware Vector Mode: Interrupt Exception Handler Address Calculation

The processor negates INTC's interrupt request when automatically acknowledging the interrupt request. However, the interrupt request to the processor do not negate if a higher priority interrupt request arrives. Even in this case, the interrupt vector number does not update to the higher priority request until the lower priority request is acknowledged by the processor.

The assertion of the interrupt acknowledge signal pushes the PRI value in the INTC_CPR onto the LIFO and updates PRI in the INTC_CPR with the new priority.

10.2 External Signal Description

The INTC does not have any direct external MCU signals. However, there are sixteen external pins which can be configured in the SIU as external interrupt request input pins. When configured for an external interrupt request function, an interrupt on that pin sets an external interrupt flag. These flags cause one of five peripheral interrupt requests to the interrupt controller.

For more information on external interrupts, the pins used, and how to configure them:

- Refer to the Signals chapter for a list and number of the external interrupt pins.
- Refer to the SIU chapter for more information on how to configure these pins.

10.3 Memory Map and Register Definition

Table 10-2 is the INTC memory map.

NOTE

To ensure compatibility with all Power Architecture devices, the TLB entry covering the INTC memory map must be configured as guarded, both in software and hardware vector modes.

- In software vector mode, the INTC_IACKR must not be read speculatively.
- In hardware vector mode, guarded writes to the INTC_CPR or INTC_EOIR complete before the interrupt acknowledge signal from the processor asserts.

Table 10-2. INTC Memory Map

| Address | Register | Bits | Access | Reset Value | Section/Page |
|---------------------|---|------|--------|-------------|----------------|
| Base (0xFFFF4_8000) | INTC_MCR—INTC module configuration register | 32 | R/W | 0x0000_0000 | 10.3.1.1/10-9 |
| Base + 0x0004 | Reserved | | | | |
| Base + 0x0008 | INTC_CPR—INTC current priority register | 32 | R/W | 0x0000_000F | 10.3.1.2/10-10 |
| Base + 0x000C | Reserved | | | | |
| Base + 0x0010 | INTC_IACKR—INTC interrupt acknowledge register ¹ | 32 | R/W | 0x0000_0000 | 10.3.1.3/10-10 |
| Base + 0x0014 | Reserved | | | | |
| Base + 0x0018 | INTC_EOIR—INTC end-of-interrupt register | 32 | W/O | 0x0000_0000 | 10.3.1.4/10-11 |
| Base + 0x001C | Reserved | | | | |

Table 10-2. INTC Memory Map (continued)

| Address | Register | Bits | Access | Reset Value | Section/Page |
|------------------------|---|------|--------|-------------|----------------|
| Base + 0x0020 | INTC_SSCIR0—INTC software set/clear interrupt register 0 | 8 | R/W | 0x00 | 10.3.1.5/10-12 |
| Base + 0x0021 | INTC_SSCIR1—INTC software set/clear interrupt register 1 | 8 | R/W | 0x00 | 10.3.1.5/10-12 |
| Base + 0x0022 | INTC_SSCIR2—INTC software set/clear interrupt register 2 | 8 | R/W | 0x00 | 10.3.1.5/10-12 |
| Base + 0x0023 | INTC_SSCIR3—INTC software set/clear interrupt register 3 | 8 | R/W | 0x00 | 10.3.1.5/10-12 |
| Base + 0x0024 | INTC_SSCIR4—INTC software set/clear interrupt register 4 | 8 | R/W | 0x00 | 10.3.1.5/10-12 |
| Base + 0x0025 | INTC_SSCIR5—INTC software set/clear interrupt register 5 | 8 | R/W | 0x00 | 10.3.1.5/10-12 |
| Base + 0x0026 | INTC_SSCIR6—INTC software set/clear interrupt register 6 | 8 | R/W | 0x00 | 10.3.1.5/10-12 |
| Base + 0x0027 | INTC_SSCIR7—INTC software set/clear interrupt register 7 | 8 | R/W | 0x00 | 10.3.1.5/10-12 |
| Base + (0x0028–0x003F) | Reserved | | | | |
| Base + (0x0040–0x0219) | INTC_PSR n —INTC priority select registers ² 0–479 | 8 | R/W | 0x00 | 10.3.1.6/10-13 |

¹ When the HVEN bit in the INTC_MCR is asserted, a read of the INTC_IACKR has no side effects.

² The PRI fields are “Reserved” for peripheral interrupt requests whose vectors are labeled as Reserved in [Table 10-7](#).

10.3.1 Register Descriptions

With the exception of the INTC_SSCIn and INTC_PSRn registers, all of the registers are 32-bits wide. Any combination of accessing the 4 bytes of a register with a single access is supported, provided that the access does not cross a register boundary. These supported accesses include types and sizes of 8 bits, aligned 16 bits, and aligned 32 bits.

Although INTC_SSCIn and INTC_PSRn are 8 bits wide, they can be accessed with a single 16-bit or 32-bit access, provided that the access does not cross a 32-bit boundary.

In software vector mode, the side effects of a read of the INTC interrupt acknowledge register (INTC_IACKR) are the same regardless of the size of the read. In either software or hardware vector mode, the size of a write to the INTC end-of-interrupt register (INTC_EOIR) does not affect the operation of the write.

10.3.1.1 INTC Module Configuration Register (INTC_MCR)

The INTC_MCR is used to configure options of the INTC.

Address: Base + 0x0000 (INTC_MCR)

Access: R/W

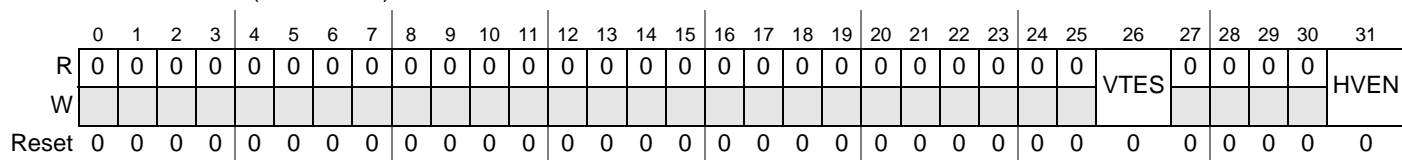

Figure 10-7. INTC Module Configuration Register (INTC_MCR)

Table 10-3. INTC_MCR Field Descriptions

| Field | Description |
|------------|---|
| 0–25 | Reserved, must be cleared. |
| 26 VTES | Vector table entry size. Controls the number of '0's to the right of INTVEC in Section 10.3.1.3, INTC Interrupt Acknowledge Register (INTC_IACKR) . If the contents of INTC_IACKR are used as an address of an entry in a vector table as in software vector mode, then the number of right-most '0's determines the size of each vector table entry. VTES impacts software vector mode operation but also affects the INTC_IACKR[INTVEC] position in both hardware vector mode and software vector mode. 0 4 bytes 1 8 bytes |
| 27–30 | Reserved, must be cleared. |
| 31 HVEN | Hardware vector enable. Controls whether the INTC is in hardware vector mode or software vector mode. Refer to Section 10.1.4, Modes of Operation , for the details of the handshaking with the processor in each mode. 0 Software vector mode 1 Hardware vector mode |

10.3.1.2 INTC Current Priority Register (INTC_CPR)

The INTC_CPR masks any peripheral or software configurable interrupt request set at the same or lower priority as the current value of the INTC_CPR[PRI] field from generating an interrupt request to the processor. When the INTC interrupt acknowledge register (INTC_IACKR) is read in software vector mode or the interrupt acknowledge signal from the processor is asserted in hardware vector mode, the value of PRI is pushed onto the LIFO, and PRI is updated with the priority of the preempting interrupt request. When the INTC end-of-interrupt register (INTC_EOIR) is written, the LIFO is popped into the INTC_CPR's PRI field.

The masking priority can be raised or lowered by writing to the PRI field, supporting the PCP. Refer to [Section 10.5.5, Priority Ceiling Protocol](#).

NOTE

On some Power Architecture MCUs, a store to raise the PRI field which closely precedes an access to a shared resource can result in a non-coherent access to that resource unless an **mbar** or **msync** followed by an **isync** sequence of instructions is executed between the accesses. An **mbar** or **msync** instruction is also necessary after accessing the resource but before lowering the PRI field. Refer to [Section 10.5.5.2, Ensuring Coherency](#).

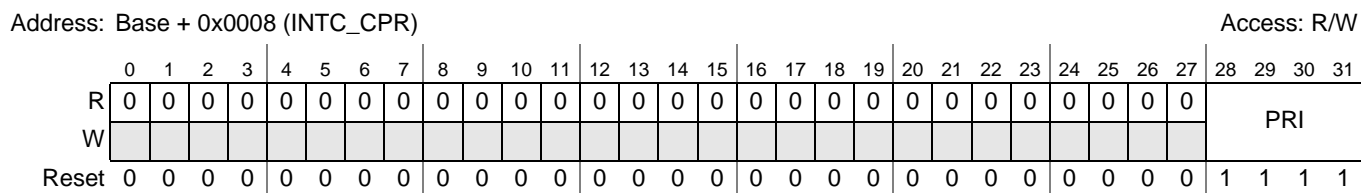

Figure 10-8. INTC Current Priority Register (INTC_CPR)

Table 10-4. INTC_CPR Field Descriptions

| Field | Description |
|--------------|---|
| 0–27 | Reserved, must be cleared. |
| 28–31 PRI | Priority. PRI is the priority of the currently executing ISR according to the field values defined below. 1111 Priority 15 (highest) 1110 Priority 14 ... 0001 Priority 1 0000 Priority 0 (lowest) |

10.3.1.3 INTC Interrupt Acknowledge Register (INTC_IACKR)

The INTC_IACKR provides a value that can be used to load the address of an ISR from a vector table. The vector table can be composed of addresses of the ISRs specific to their respective interrupt vectors.

In software vector mode, reading the INTC_IACKR acknowledges the INTC's interrupt request. Refer to [Section 10.1.4.1, Software Vector Mode](#), for a detailed description of the effect on the interrupt request to the processor. The reading also pushes the PRI value in the INTC current priority register (INTC_CPR) onto the LIFO and updates PRI in the INTC_CPR with the priority of the interrupt request. The side effect

from the reads in software vector mode, that is, the effect on the interrupt request to the processor, the current priority, and the LIFO, are the same regardless of the size of the read

Reading the INTC_IACKR does not have side effects in hardware vector mode.

NOTE

In software vector mode, the INTC_IACKR must be read before setting MSR[EE]. No synchronization instruction is needed after reading the INTC_IACKR and before setting MSR[EE].

However, the time for the processor to recognize the assertion or negation of the external input to it is not defined by the book E architecture and can be greater than 0. Therefore, insert instructions between the reading of the INTC_IACKR and the setting of MSR[EE] that consumes at least two processor clock cycles. This length of time allows the interrupt request negation to propagate through the processor before MSR[EE] is set.

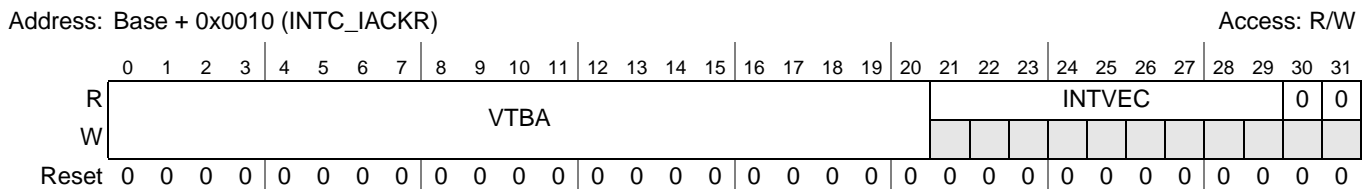

Figure 10-9. INTC Interrupt Acknowledge Register (INTC_IACKR)—INTC_MCR[VTES] = 0

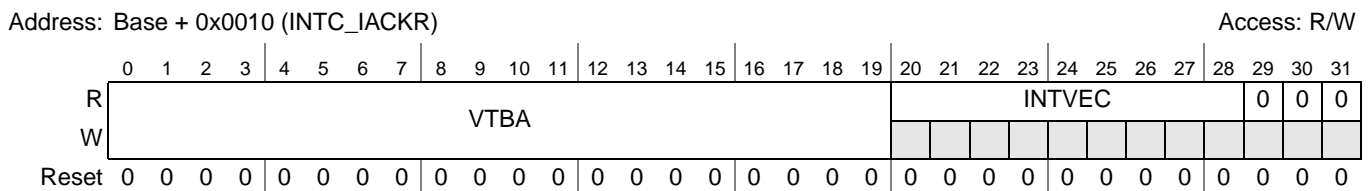

Figure 10-10. INTC Interrupt Acknowledge Register (INTC_IACKR)—INTC_MCR[VTES] = 1

Table 10-5. INTC_IACKR Field Descriptions

| Field | Description |
|-----------------|--|
| 0–20 VTBA | Vector table base address. Can be the base address of a vector table of addresses of ISRs. The VTBA only uses the left-most 20 bits when the VTES bit in INTC_MCR is asserted. |
| 21–29 INTVEC | Interrupt vector. Vector of peripheral or software-configurable interrupt requests that caused the interrupt request to the processor. When the interrupt request to the processor asserts, the INTVEC is updated, whether the INTC is in software or hardware vector mode. Note: If INTC_MCR[VTES] = 1, then the INTVEC field is shifted left one position to bits 20–28. VTBA is then shortened by one bit to bits 0–19. |
| 30–31 | Reserved, must be cleared. |

10.3.1.4 INTC End-of-Interrupt Register (INTC_EOIR)

Writing to the INTC_EOIR signals the end of the servicing of the interrupt request. When the INTC_EOIR is written, the priority last pushed on the LIFO is popped into INTC_CPR. The values and size of data

written to the INTC_EOIR are ignored. Those values and sizes written to this register neither update the INTC_EOIR contents or affect whether the LIFO pops. For possible future compatibility, write four bytes of all 0's to the INTC_EOIR.

Reading the INTC_EOIR has no effect on the LIFO.

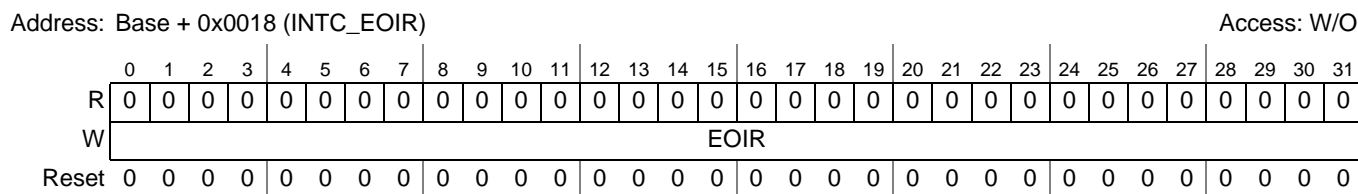

Figure 10-11. INTC End-of-Interrupt Register (INTC_EOIR)

10.3.1.5 INTC Software Set/Clear Interrupt Registers (INTC_SSCIR0–7)

The INTC_SSCIR n support the setting or clearing of software configurable interrupt requests. These registers contain eight independent sets of bits to set and clear a corresponding flag bit by software. With the exception of being set by software, this flag bit behaves the same as a flag bit set within a peripheral. This flag bit generates an interrupt request within the INTC just like a peripheral interrupt request. Writing a 1 to SET n leaves SET n unchanged at 0 but sets CLR n . Writing a 0 to SET n has no effect. CLR n is the flag bit. Writing a 1 to CLR n clears it. Writing a 0 to CLR n has no effect. If a 1 is written to a pair SET n and CLR n bits at the same time, CLR n is asserted, regardless of whether CLR n was asserted before the write.

Although INTC_SSCIR n is 8 bits wide, it can be accessed with a single 16-bit or 32-bit access, provided that the access does not cross a 32-bit boundary.

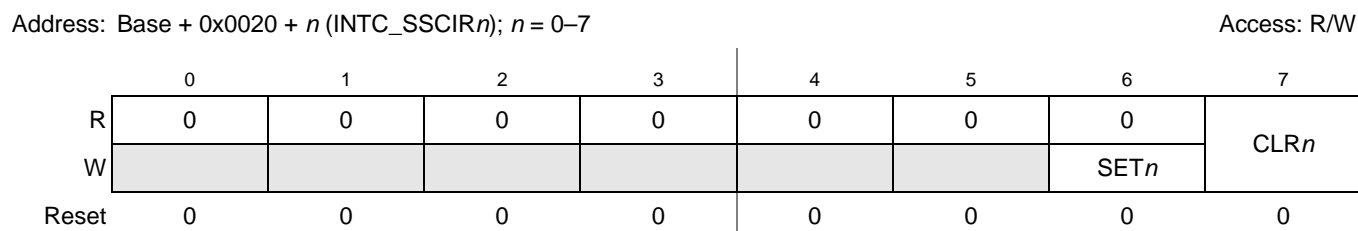

Figure 10-12. INTC Software Set/Clear Interrupt Register (INTC_SSCIR n)

Table 10-6. INTC_SSCIR n Field Descriptions

| Field | Description |
|--------------|--|
| 0–5 | Reserved, must be cleared. |
| 6 SET n | Set flag bits. Writing a 1 sets the corresponding CLR n bit. Writing a 0 has no effect. Each SET n is always read as a 0. |
| 7 CLR n | Clear flag bits. CLR n is the flag bit. Writing a 1 to CLR n clears it provided that a 1 is not written simultaneously to its corresponding SET n bit. Writing a 0 to CLR n has no effect. 0 Interrupt request not pending within INTC. 1 Interrupt request pending within INTC. |

10.3.1.6 INTC Priority Select Registers (INTC_PSR0–479)

The INTC_PSR n allows you to select a priority for each interrupt request source (peripheral IRQs or software-configurable IRQs). Each priority select register (INTC_PSR n) is assigned to the IRQ source vector with the same number. For example, the software-configurable IRQs 0–7 are assigned vectors 0–7, and their priorities are configured in INTC_PSR0–INTC_PSR7, respectively. The peripheral interrupt requests are assigned vectors 8–479 and their priorities are configured in priority select registers INTC_PSR8 through INTC_PSR479, respectively.

Although INTC_PSR n is 8 bits wide, you can use a single 16-bit or 32-bit access, provided that it does not cross a 32-bit boundary.

NOTE

Do not modify the PRI n field in INTC_PSR n when the IRQ is asserted.

Address: Base + 0x0040 + n (INTC_PSR n); $n = 0-479$

Access: R/W

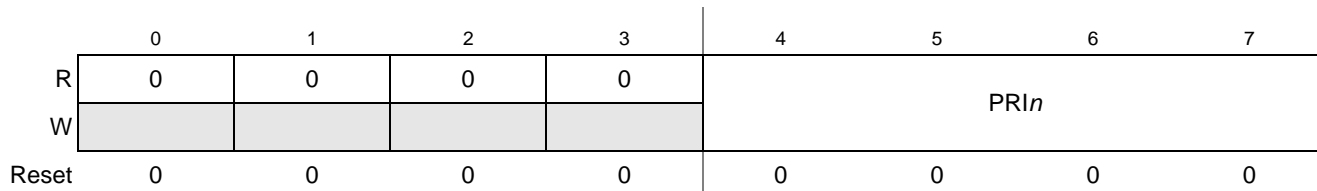

Figure 10-13. INTC Priority Select Registers (INTC_PSR n)

Table 10-7. INTC_PSR n Field Descriptions

| Field | Description |
|----------------|--|
| 0–3 | Reserved, must be cleared. |
| 4–7 PRI n | Priority select. Selects the priority for corresponding interrupt request. 1111 Priority 15 (highest) 1110 Priority 14 ... 0001 Priority 1 0000 Priority 0 (lowest) |

10.4 Functional Description

10.4.1 Interrupt Request Sources

The INTC has two types of interrupt requests, peripheral and software configurable. The assignments between the interrupt requests from the modules to the vectors for input to the e200z7 are shown in Table 10-8. The Hardware Vector Mode Offset column lists the IRQ-specific offsets when using hardware vector mode. The Source column shows the C language syntax for the register bit label:

module_register[bit]. Interrupt requests from the same module location are ORed together. The individual interrupt priorities are selected in INTC_PSR n , where the priority select register is assigned according to the vector number.

Table 10-8. Interrupt Request Sources

| Hardware Vector Mode Offset | Vector Number ¹ | Source ² | Description |
|-----------------------------|----------------------------|----------------------------------|--|
| Software | | | |
| 0x0000 | 0 | INTC_SSCIR0[CLR0] | INTC software configurable. Clear flag 0. |
| 0x0010 | 1 | INTC_SSCIR1[CLR1] | INTC software configurable. Clear flag 1. |
| 0x0020 | 2 | INTC_SSCIR2[CLR2] | INTC software configurable. Clear flag 2. |
| 0x0030 | 3 | INTC_SSCIR3[CLR3] | INTC software configurable. Clear flag 3. |
| 0x0040 | 4 | INTC_SSCIR4[CLR4] | INTC software configurable. Clear flag 4. |
| 0x0050 | 5 | INTC_SSCIR5[CLR5] | INTC software configurable. Clear flag 5. |
| 0x0060 | 6 | INTC_SSCIR6[CLR6] | INTC software configurable. Clear flag 6. |
| 0x0070 | 7 | INTC_SSCIR7[CLR7] | INTC software configurable. Clear flag 7. |
| Watchdog / ECC | | | |
| 0x0080 | 8 | ECSM_SWTIR[SWTIC] | ECSM software watchdog interrupt flag |
| 0x0090 | 9 | ECSM_ESR[RNCE] ECSM_ESR[FNCE] | ECSM combined interrupt requests: <ul style="list-style-type: none"> • Internal SRAM non-correctable error • Flash non-correctable error |
| eDMA2 A | | | |
| 0x00A0 | 10 | EDMA_ERL[ERR31:ERR0] | eDMA_A channel error flags 31–0 |
| 0x00B0 | 11 | EDMA_IRQRL[INT00] | eDMA_A channel interrupt 0 |
| 0x00C0 | 12 | EDMA_IRQRL[INT01] | eDMA_A channel interrupt 1 |
| 0x00D0 | 13 | EDMA_IRQRL[INT02] | eDMA_A channel interrupt 2 |
| 0x00E0 | 14 | EDMA_IRQRL[INT03] | eDMA_A channel interrupt 3 |
| 0x00F0 | 15 | EDMA_IRQRL[INT04] | eDMA_A channel interrupt 4 |
| 0x0100 | 16 | EDMA_IRQRL[INT05] | eDMA_A channel interrupt 5 |
| 0x0110 | 17 | EDMA_IRQRL[INT06] | eDMA_A channel interrupt 6 |
| 0x0120 | 18 | EDMA_IRQRL[INT07] | eDMA_A channel interrupt 7 |
| 0x0130 | 19 | EDMA_IRQRL[INT08] | eDMA_A channel interrupt 8 |
| 0x0140 | 20 | EDMA_IRQRL[INT09] | eDMA_A channel interrupt 9 |
| 0x0150 | 21 | EDMA_IRQRL[INT10] | eDMA_A channel interrupt 10 |
| 0x0160 | 22 | EDMA_IRQRL[INT11] | eDMA_A channel interrupt 11 |
| 0x0170 | 23 | EDMA_IRQRL[INT12] | eDMA_A channel interrupt 12 |
| 0x0180 | 24 | EDMA_IRQRL[INT13] | eDMA_A channel interrupt 13 |
| 0x0190 | 25 | EDMA_IRQRL[INT14] | eDMA_A channel interrupt 14 |
| 0x01A0 | 26 | EDMA_IRQRL[INT15] | eDMA_A channel interrupt 15 |

Table 10-8. Interrupt Request Sources (continued)

| Hardware Vector Mode Offset | Vector Number ¹ | Source ² | Description |
|-----------------------------|----------------------------|----------------------|--|
| 0x01B0 | 27 | EDMA_IRQRL[INT16] | eDMA_A channel interrupt 16 |
| 0x01C0 | 28 | EDMA_IRQRL[INT17] | eDMA_A channel interrupt 17 |
| 0x01D0 | 29 | EDMA_IRQRL[INT18] | eDMA_A channel interrupt 18 |
| 0x01E0 | 30 | EDMA_IRQRL[INT19] | eDMA_A channel interrupt 19 |
| 0x01F0 | 31 | EDMA_IRQRL[INT20] | eDMA_A channel interrupt 20 |
| 0x0200 | 32 | EDMA_IRQRL[INT21] | eDMA_A channel interrupt 21 |
| 0x0210 | 33 | EDMA_IRQRL[INT22] | eDMA_A channel interrupt 22 |
| 0x0220 | 34 | EDMA_IRQRL[INT23] | eDMA_A channel interrupt 23 |
| 0x0230 | 35 | EDMA_IRQRL[INT24] | eDMA_A channel interrupt 24 |
| 0x0240 | 36 | EDMA_IRQRL[INT25] | eDMA_A channel interrupt 25 |
| 0x0250 | 37 | EDMA_IRQRL[INT26] | eDMA_A channel interrupt 26 |
| 0x0260 | 38 | EDMA_IRQRL[INT27] | eDMA_A channel interrupt 27 |
| 0x0270 | 39 | EDMA_IRQRL[INT28] | eDMA_A channel interrupt 28 |
| 0x0280 | 40 | EDMA_IRQRL[INT29] | eDMA_A channel interrupt 29 |
| 0x0290 | 41 | EDMA_IRQRL[INT30] | eDMA_A channel interrupt 30 |
| 0x02A0 | 42 | EDMA_IRQRL[INT31] | eDMA_A channel interrupt 31 |
| PLL | | | |
| 0x02B0 | 43 | FMPLL_SYNSR[LOCF] | FMPLL loss-of-clock flag |
| 0x02C0 | 44 | FMPLL_SYNSR[LOLF] | FMPLL loss-of-lock flag |
| SIU | | | |
| 0x02D0 | 45 | SIU_OSR[OVF15:OVF0] | SIU combined overrun interrupt requests of the external interrupt overrun flags 15–0 |
| 0x02E0 | 46 | SIU_EISR[EIF0] | SIU external interrupt flag 0 |
| 0x02F0 | 47 | SIU_EISR[EIF1] | SIU external interrupt flag 1 |
| 0x0300 | 48 | SIU_EISR[EIF2] | SIU external interrupt flag 2 |
| 0x0310 | 49 | SIU_EISR[EIF3] | SIU external interrupt flag 3 |
| 0x0320 | 50 | SIU_EISR[EIF15:EIF4] | SIU external interrupt flags 15–4 |
| eMIOS | | | |
| 0x0330 | 51 | EMIOS_GFR[F0] | eMIOS channel 0 flag |
| 0x0340 | 52 | EMIOS_GFR[F1] | eMIOS channel 1 flag |
| 0x0350 | 53 | EMIOS_GFR[F2] | eMIOS channel 2 flag |
| 0x0360 | 54 | EMIOS_GFR[F3] | eMIOS channel 3 flag |

Table 10-8. Interrupt Request Sources (continued)

| Hardware Vector Mode Offset | Vector Number ¹ | Source ² | Description |
|-----------------------------|----------------------------|---|---|
| 0x0370 | 55 | EMIOS_GFR[F4] | eMIOS channel 4 flag |
| 0x0380 | 56 | EMIOS_GFR[F5] | eMIOS channel 5 flag |
| 0x0390 | 57 | EMIOS_GFR[F6] | eMIOS channel 6 flag |
| 0x03A0 | 58 | EMIOS_GFR[F7] | eMIOS channel 7 flag |
| 0x03B0 | 59 | EMIOS_GFR[F8] | eMIOS channel 8 flag |
| 0x03C0 | 60 | EMIOS_GFR[F9] | eMIOS channel 9 flag |
| 0x03D0 | 61 | EMIOS_GFR[F10] | eMIOS channel 10 flag |
| 0x03E0 | 62 | EMIOS_GFR[F11] | eMIOS channel 11 flag |
| 0x03F0 | 63 | EMIOS_GFR[F12] | eMIOS channel 12 flag |
| 0x0400 | 64 | EMIOS_GFR[F13] | eMIOS channel 13 flag |
| 0x0410 | 65 | EMIOS_GFR[F14] | eMIOS channel 14 flag |
| 0x0420 | 66 | EMIOS_GFR[F15] | eMIOS channel 15 flag |
| eTPU A | | | |
| 0x0430 | 67 | ETPU_MCR[MGEA] ETPU_MCR[MGEB] ETPU_MCR[ILFA] ETPU_MCR[ILFB] ETPU_MCR[SCMMISF] | eTPU global exception |
| 0x0440 | 68 | ETPU_CISR_A[CIS0] | eTPU engine A channel 0 interrupt status |
| 0x0450 | 69 | ETPU_CISR_A[CIS1] | eTPU engine A channel 1 interrupt status |
| 0x0460 | 70 | ETPU_CISR_A[CIS2] | eTPU engine A channel 2 interrupt status |
| 0x0470 | 71 | ETPU_CISR_A[CIS3] | eTPU engine A channel 3 interrupt status |
| 0x0480 | 72 | ETPU_CISR_A[CIS4] | eTPU engine A channel 4 interrupt status |
| 0x0490 | 73 | ETPU_CISR_A[CIS5] | eTPU engine A channel 5 interrupt status |
| 0x04A0 | 74 | ETPU_CISR_A[CIS6] | eTPU engine A channel 6 interrupt status |
| 0x04B0 | 75 | ETPU_CISR_A[CIS7] | eTPU engine A channel 7 interrupt status |
| 0x04C0 | 76 | ETPU_CISR_A[CIS8] | eTPU engine A channel 8 interrupt status |
| 0x04D0 | 77 | ETPU_CISR_A[CIS9] | eTPU engine A channel 9 interrupt status |
| 0x04E0 | 78 | ETPU_CISR_A[CIS10] | eTPU engine A channel 10 interrupt status |
| 0x04F0 | 79 | ETPU_CISR_A[CIS11] | eTPU engine A channel 11 interrupt status |
| 0x0500 | 80 | ETPU_CISR_A[CIS12] | eTPU engine A channel 12 interrupt status |
| 0x0510 | 81 | ETPU_CISR_A[CIS13] | eTPU engine A channel 13 interrupt status |
| 0x0520 | 82 | ETPU_CISR_A[CIS14] | eTPU engine A channel 14 interrupt status |

Table 10-8. Interrupt Request Sources (continued)

| Hardware Vector Mode Offset | Vector Number ¹ | Source ² | Description |
|-----------------------------|----------------------------|---|---|
| 0x0530 | 83 | ETPU_CISR_A[CIS15] | eTPU engine A channel 15 interrupt status |
| 0x0540 | 84 | ETPU_CISR_A[CIS16] | eTPU engine A channel 16 interrupt status |
| 0x0550 | 85 | ETPU_CISR_A[CIS17] | eTPU engine A channel 17 interrupt status |
| 0x0560 | 86 | ETPU_CISR_A[CIS18] | eTPU engine A channel 18 interrupt status |
| 0x0570 | 87 | ETPU_CISR_A[CIS19] | eTPU engine A channel 19 interrupt status |
| 0x0580 | 88 | ETPU_CISR_A[CIS20] | eTPU engine A channel 20 interrupt status |
| 0x0590 | 89 | ETPU_CISR_A[CIS21] | eTPU engine A channel 21 interrupt status |
| 0x05A0 | 90 | ETPU_CISR_A[CIS22] | eTPU engine A channel 22 interrupt status |
| 0x05B0 | 91 | ETPU_CISR_A[CIS23] | eTPU engine A channel 23 interrupt status |
| 0x05C0 | 92 | ETPU_CISR_A[CIS24] | eTPU engine A channel 24 interrupt status |
| 0x05D0 | 93 | ETPU_CISR_A[CIS25] | eTPU engine A channel 25 interrupt status |
| 0x05E0 | 94 | ETPU_CISR_A[CIS26] | eTPU engine A channel 26 interrupt status |
| 0x05F0 | 95 | ETPU_CISR_A[CIS27] | eTPU engine A channel 27 interrupt status |
| 0x0600 | 96 | ETPU_CISR_A[CIS28] | eTPU engine A channel 28 interrupt status |
| 0x0610 | 97 | ETPU_CISR_A[CIS29] | eTPU engine A channel 29 interrupt status |
| 0x0620 | 98 | ETPU_CISR_A[CIS30] | eTPU engine A channel 30 interrupt status |
| 0x0630 | 99 | ETPU_CISR_A[CIS31] | eTPU engine A channel 31 interrupt status |
| eQADC A | | | |
| 0x0640 | 100 | EQADC_FISRx[TORF] EQADC_FISRx[RFOF] EQADC_FISRx[CFUF] | eQADC A combined overrun interrupt requests from all of the FIFOs: <ul style="list-style-type: none"> • Trigger overrun, • Receive FIFO overflow, • Command FIFO underflow |
| 0x0650 | 101 | EQADC_FISR0[NCF] | eQADC A command FIFO 0 non-coherency flag |
| 0x0660 | 102 | EQADC_FISR0[PF] | eQADC A command FIFO 0 pause flag |
| 0x0670 | 103 | EQADC_FISR0[EOQF] | eQADC A command FIFO 0 command queue end-of-queue flag |
| 0x0680 | 104 | EQADC_FISR0[CFFF] | eQADC A command FIFO 0 fill flag |
| 0x0690 | 105 | EQADC_FISR0[RFDF] | eQADC A receive FIFO 0 drain flag |
| 0x06A0 | 106 | EQADC_FISR1[NCF] | eQADC A command FIFO 1 non-coherency flag |
| 0x06B0 | 107 | EQADC_FISR1[PF] | eQADC A command FIFO 1 pause flag |
| 0x06C0 | 108 | EQADC_FISR1[EOQF] | eQADC A command FIFO 1 command queue end-of-queue flag |
| 0x06D0 | 109 | EQADC_FISR1[CFFF] | eQADC A command FIFO 1 fill flag |
| 0x06E0 | 110 | EQADC_FISR1[RFDF] | eQADC A receive FIFO 1 drain flag |

Table 10-8. Interrupt Request Sources (continued)

| Hardware Vector Mode Offset | Vector Number ¹ | Source ² | Description |
|-----------------------------|----------------------------|----------------------------------|--|
| 0x06F0 | 111 | EQADC_FISR2[NCF] | eQADC A command FIFO 2 non-coherency flag |
| 0x0700 | 112 | EQADC_FISR2[PF] | eQADC A command FIFO 2 pause flag |
| 0x0710 | 113 | EQADC_FISR2[EOQF] | eQADC A command FIFO 2 command queue end-of-queue flag |
| 0x0720 | 114 | EQADC_FISR2[CFFF] | eQADC A command FIFO 2 fill flag |
| 0x0730 | 115 | EQADC_FISR2[RDFD] | eQADC A receive FIFO 2 drain flag |
| 0x0740 | 116 | EQADC_FISR3[NCF] | eQADC A command FIFO 3 non-coherency flag |
| 0x0750 | 117 | EQADC_FISR3[PF] | eQADC A command FIFO 3 pause flag |
| 0x0760 | 118 | EQADC_FISR3[EOQF] | eQADC A command FIFO 3 command queue end-of-queue flag |
| 0x0770 | 119 | EQADC_FISR3[CFFF] | eQADC A command FIFO 3 fill flag |
| 0x0780 | 120 | EQADC_FISR3[RDFD] | eQADC A receive FIFO 3 drain flag |
| 0x0790 | 121 | EQADC_FISR4[NCF] | eQADC A command FIFO 4 non-coherency flag |
| 0x07A0 | 122 | EQADC_FISR4[PF] | eQADC A command FIFO 4 pause flag |
| 0x07B0 | 123 | EQADC_FISR4[EOQF] | eQADC A command FIFO 4 command queue end-of-queue flag |
| 0x07C0 | 124 | EQADC_FISR4[CFFF] | eQADC A command FIFO 4 fill flag |
| 0x07D0 | 125 | EQADC_FISR4[RDFD] | eQADC A receive FIFO 4 drain flag |
| 0x07E0 | 126 | EQADC_FISR5[NCF] | eQADC A command FIFO 5 non-coherency flag |
| 0x07F0 | 127 | EQADC_FISR5[PF] | eQADC A command FIFO 5 pause flag |
| 0x0800 | 128 | EQADC_FISR5[EOQF] | eQADC A command FIFO 5 command queue end-of-queue flag |
| 0x0810 | 129 | EQADC_FISR5[CFFF] | eQADC A command FIFO 5 fill flag |
| 0x0820 | 130 | EQADC_FISR5[RDFD] | eQADC A receive FIFO 5 drain flag |
| DSPI B, DSPI C, DSPI D | | | |
| 0x0830 | 131 | DSPI_BSR[TFUF] DSPI_BSR[RFOF] | DSPI B combined overrun interrupt requests: <ul style="list-style-type: none"> • Transmit FIFO underflow • Receive FIFO overflow |
| 0x0840 | 132 | DSPI_BSR[EOQF] | DSPI B transmit FIFO end-of-queue flag |
| 0x0850 | 133 | DSPI_BSR[TFFF] | DSPI B Tx FIFO Fill request |
| 0x0860 | 134 | DSPI_BSR[TCF] | DSPI B Tx complete |
| 0x0870 | 135 | DSPI_BSR[RDFD] | DSPI B Rx FIFO drain request |
| 0x0880 | 136 | DSPI_CSR[TFUF] DSPI_CSR[RFOF] | DSPI C combined overrun interrupt requests: <ul style="list-style-type: none"> • Transmit FIFO underflow • Receive FIFO overflow |
| 0x0890 | 137 | DSPI_CSR[EOQF] | DSPI C transmit FIFO end-of-queue flag |
| 0x08A0 | 138 | DSPI_CSR[TFFF] | DSPI C Tx FIFO Fill request |

Table 10-8. Interrupt Request Sources (continued)

| Hardware Vector Mode Offset | Vector Number ¹ | Source ² | Description |
|-----------------------------|----------------------------|--|--|
| 0x08B0 | 139 | DSPI_CSR[TCF] | DSPI C Tx complete |
| 0x08C0 | 140 | DSPI_CSR[RFDF] | DSPI C Rx FIFO drain request |
| 0x08D0 | 141 | DSPI_DSR[TFUF] DSPI_DSR[RFOF] | DSPI D combined overrun interrupt requests: <ul style="list-style-type: none"> • Transmit FIFO underflow • Receive FIFO overflow |
| 0x08E0 | 142 | DSPI_DSR[EOQF] | DSPI D transmit FIFO end-of-queue flag |
| 0x08F0 | 143 | DSPI_DSR[TFFF] | DSPI D Tx FIFO Fill request |
| 0x0900 | 144 | DSPI_DSR[TCF] | DSPI D Tx complete |
| 0x0910 | 145 | DSPI_DSR[RFDF] | DSPI D Rx FIFO drain request |
| eSCI A and B | | | |
| 0x0920 | 146 | ESCIA_IFSR1[TDRE] ESCIA_IFSR1[TC] ESCIA_IFSR1[RDRF] ESCIA_IFSR1[IDLE] ESCIA_IFSR1[OR] ESCIA_IFSR1[NF] ESCIA_IFSR1[FE] ESCIA_IFSR1[PF] ESCIA_IFSR1[BERR] ESCIA_IFSR2[RXRDY] ESCIA_IFSR2[TXRDY] ESCIA_IFSR2[LWAKE] ESCIA_IFSR2[STO] ESCIA_IFSR2[PBERR] ESCIA_IFSR2[CERR] ESCIA_IFSR2[CKERR] ESCIA_IFSR2[FRC] ESCIA_IFSR2[OVFL] ESCIA_IFSR2[UREQ] | Combined interrupt requests of eSCI module A: <ul style="list-style-type: none"> • LIN status register 1 • LIN status register 2 • SCI status register 2 • Transmit data register empty • Transmit complete • Receive data register full • Idle line • Overrun • Noise flag • Framing error flag • Parity error flag interrupt requests • Bit error interrupt request • Receive data ready • Transmit data ready • Received LIN wakeup signal • Slave timeout • Physical bus error • CRC error • Checksum error • Frame complete interrupts requests • Receive register overflow • Unrequested data received |
| 0x0930–0x0940 | 147–148 | | Reserved |

Table 10-8. Interrupt Request Sources (continued)

| Hardware Vector Mode Offset | Vector Number ¹ | Source ² | Description |
|-----------------------------|----------------------------|--|--|
| 0x0950 | 149 | ESCIB_IFSR1[TDRE] ESCIB_IFSR1[TC] ESCIB_IFSR1[RDRF] ESCIB_IFSR1[IDLE] ESCIB_IFSR1[OR] ESCIB_IFSR1[NF] ESCIB_IFSR1[FE] ESCIB_IFSR1[PF] ESCIB_IFSR1[BERR] ESCIB_IFSR2[RXRDY] ESCIB_IFSR2[TXRDY] ESCIB_IFSR2[LWAKE] ESCIB_IFSR2[STO] ESCIB_IFSR2[PBERR] ESCIB_IFSR2[CERR] ESCIB_IFSR2[CKERR] ESCIB_IFSR2[FRC] ESCIB_IFSR2[OVFL] ESCIB_IFSR2[UREQ] | Combined interrupt requests of eSCI module B: <ul style="list-style-type: none"> • LIN status register 1 • LIN status register 2 • SCI status register 2 • Transmit data register empty • Transmit complete • Receive data register full • Idle line • Overrun • Noise flag • Framing error flag • Parity error flag interrupt requests • Bit error interrupt request • Receive data ready • Transmit data ready • Received LIN wakeup signal • Slave timeout • Physical bus error • CRC error • Checksum error • Frame complete interrupts requests • Receive register overflow • Unrequested data received |
| 0x0960–0x0970 | 150–151 | Reserved | |
| FlexCAN A and FlexCAN C | | | |
| 0x0980 | 152 | CANA_ESR[BOFF_INT] CANA_ESR[TWRN_INT] CANA_ESR[RWRN_INT] | FlexCAN A bus off interrupt FlexCAN A transmit warning interrupt FlexCAN A receive warning interrupt |
| 0x0990 | 153 | CANA_ESR[ERR_INT] | FlexCAN A error interrupt |
| 0x09A0 | 154 | Reserved | |
| 0x09B0 | 155 | CANA_IFRL[BUF0] | FlexCAN A buffer 0 interrupt |
| 0x09C0 | 156 | CANA_IFRL[BUF1] | FlexCAN A buffer 1 interrupt |
| 0x09D0 | 157 | CANA_IFRL[BUF2] | FlexCAN A buffer 2 interrupt |
| 0x09E0 | 158 | CANA_IFRL[BUF3] | FlexCAN A buffer 3 interrupt |
| 0x09F0 | 159 | CANA_IFRL[BUF4] | FlexCAN A buffer 4 interrupt |
| 0x0A00 | 160 | CANA_IFRL[BUF5] | FlexCAN A buffer 5 interrupt |
| 0x0A10 | 161 | CANA_IFRL[BUF6] | FlexCAN A buffer 6 interrupt |
| 0x0A20 | 162 | CANA_IFRL[BUF7] | FlexCAN A buffer 7 interrupt |
| 0x0A30 | 163 | CANA_IFRL[BUF8] | FlexCAN A buffer 8 interrupt |
| 0x0A40 | 164 | CANA_IFRL[BUF9] | FlexCAN A buffer 9 interrupt |
| 0x0A50 | 165 | CANA_IFRL[BUF10] | FlexCAN A buffer 10 interrupt |
| 0x0A60 | 166 | CANA_IFRL[BUF11] | FlexCAN A buffer 11 interrupt |

Table 10-8. Interrupt Request Sources (continued)

| Hardware Vector Mode Offset | Vector Number ¹ | Source ² | Description |
|-----------------------------|----------------------------|--|--|
| 0x0A70 | 167 | CANA_IFRL[BUF12] | FlexCAN A buffer 12 interrupt |
| 0x0A80 | 168 | CANA_IFRL[BUF13] | FlexCAN A buffer 13 interrupt |
| 0x0A90 | 169 | CANA_IFRL[BUF14] | FlexCAN A buffer 14 interrupt |
| 0x0AA0 | 170 | CANA_IFRL[BUF15] | FlexCAN A buffer 15 interrupt |
| 0x0AB0 | 171 | CANA_IFRL[BUF31:BUF16] | FlexCAN A buffers 31–16 interrupts |
| 0x0AC0 | 172 | CANA_IFRH[BUF63:BUF32] | FlexCAN A buffers 63–32 interrupts |
| 0x0AD0 | 173 | CANC_ESR[BOFF_INT] CANC_ESR[TWRN_INT] CANC_ESR[RWRN_INT] | FlexCAN C bus off interrupt FlexCAN C transmit warning interrupt FlexCAN C receive warning interrupt |
| 0x0AE0 | 174 | CANC_ESR[ERR_INT] | FlexCAN C error interrupt |
| 0x0AF0 | 175 | Reserved | |
| 0x0B00 | 176 | CANC_IFRL[BUF0] | FlexCAN C buffer 0 interrupt |
| 0x0B10 | 177 | CANC_IFRL[BUF1] | FlexCAN C buffer 1 interrupt |
| 0x0B20 | 178 | CANC_IFRL[BUF2] | FlexCAN C buffer 2 interrupt |
| 0x0B30 | 179 | CANC_IFRL[BUF3] | FlexCAN C buffer 3 interrupt |
| 0x0B40 | 180 | CANC_IFRL[BUF4] | FlexCAN C buffer 4 interrupt |
| 0x0B50 | 181 | CANC_IFRL[BUF5] | FlexCAN C buffer 5 interrupt |
| 0x0B60 | 182 | CANC_IFRL[BUF6] | FlexCAN C buffer 6 interrupt |
| 0x0B70 | 183 | CANC_IFRL[BUF7] | FlexCAN C buffer 7 interrupt |
| 0x0B80 | 184 | CANC_IFRL[BUF8] | FlexCAN C buffer 8 interrupt |
| 0x0B90 | 185 | CANC_IFRL[BUF9] | FlexCAN C buffer 9 interrupt |
| 0x0BA0 | 186 | CANC_IFRL[BUF10] | FlexCAN C buffer 10 interrupt |
| 0x0BB0 | 187 | CANC_IFRL[BUF11] | FlexCAN C buffer 11 interrupt |
| 0x0BC0 | 188 | CANC_IFRL[BUF12] | FlexCAN C buffer 12 interrupt |
| 0x0BD0 | 189 | CANC_IFRL[BUF13] | FlexCAN C buffer 13 interrupt |
| 0x0BE0 | 190 | CANC_IFRL[BUF14] | FlexCAN C buffer 14 interrupt |
| 0x0BF0 | 191 | CANC_IFRL[BUF15] | FlexCAN C buffer 15 interrupt |
| 0x0C00 | 192 | CANC_IFRL[BUF31:BUF16] | FlexCAN C buffers 31–16 interrupts |
| 0x0C10 | 193 | CANC_IFRH[BUF63:BUF32] | FlexCAN C buffers 63–32 interrupts |
| 0x0C20–0x0C40 | 194–196 | Reserved | |
| Decimation Filter A | | | |
| 0x0C50 | 197 | DEC_A | Decimation Filter A input (fill) |

Table 10-8. Interrupt Request Sources (continued)

| Hardware Vector Mode Offset | Vector Number ¹ | Source ² | Description |
|-----------------------------|----------------------------|-----------------------|------------------------------------|
| 0x0C60 | 198 | DEC_A | Decimation Filter A output (drain) |
| 0x0C70 | 199 | DEC_A | Decimation Filter A error |
| STM | | | |
| 0x0C80 | 200 | STM[0] | System timer module |
| 0x0C90 | 201 | STM[1:3] | System timer module |
| eMIOS | | | |
| 0x0CA0 | 202 | EMIOS_GFR[F16] | eMIOS channel 16 flag |
| 0x0CB0 | 203 | EMIOS_GFR[F17] | eMIOS channel 17 flag |
| 0x0CC0 | 204 | EMIOS_GFR[F18] | eMIOS channel 18 flag |
| 0x0CD0 | 205 | EMIOS_GFR[F19] | eMIOS channel 19 flag |
| 0x0CE0 | 206 | EMIOS_GFR[F20] | eMIOS channel 20 flag |
| 0x0CF0 | 207 | EMIOS_GFR[F21] | eMIOS channel 21 flag |
| 0x0D00 | 208 | EMIOS_GFR[F22] | eMIOS channel 22 flag |
| 0x0D10 | 209 | EMIOS_GFR[F23] | eMIOS channel 23 flag |
| eDMA2 A (continued) | | | |
| 0x0D20 | 210 | EDMA_ERL[ERR63:ERR32] | eDMA_A channel error flags 63–32 |
| 0x0D30 | 211 | EDMA_IRQRH[INT32] | eDMA_A channel interrupt 32 |
| 0x0D40 | 212 | EDMA_IRQRH[INT33] | eDMA_A channel interrupt 33 |
| 0x0D50 | 213 | EDMA_IRQRH[INT34] | eDMA_A channel interrupt 34 |
| 0x0D60 | 214 | EDMA_IRQRH[INT35] | eDMA_A channel interrupt 35 |
| 0x0D70 | 215 | EDMA_IRQRH[INT36] | eDMA_A channel interrupt 36 |
| 0x0D80 | 216 | EDMA_IRQRH[INT37] | eDMA_A channel interrupt 37 |
| 0x0D90 | 217 | EDMA_IRQRH[INT38] | eDMA_A channel interrupt 38 |
| 0x0DA0 | 218 | EDMA_IRQRH[INT39] | eDMA_A channel interrupt 39 |
| 0x0DB0 | 219 | EDMA_IRQRH[INT40] | eDMA_A channel interrupt 40 |
| 0x0DC0 | 220 | EDMA_IRQRH[INT41] | eDMA_A channel interrupt 41 |
| 0x0DD0 | 221 | EDMA_IRQRH[INT42] | eDMA_A channel interrupt 42 |
| 0x0DE0 | 222 | EDMA_IRQRH[INT43] | eDMA_A channel interrupt 43 |
| 0x0DF0 | 223 | EDMA_IRQRH[INT44] | eDMA_A channel interrupt 44 |
| 0x0E00 | 224 | EDMA_IRQRH[INT45] | eDMA_A channel interrupt 45 |
| 0x0E10 | 225 | EDMA_IRQRH[INT46] | eDMA_A channel interrupt 46 |

Table 10-8. Interrupt Request Sources (continued)

| Hardware Vector Mode Offset | Vector Number ¹ | Source ² | Description |
|-----------------------------|----------------------------|---------------------|---|
| 0x0E20 | 226 | EDMA_IRQRH[INT47] | eDMA_A channel interrupt 47 |
| 0x0E30 | 227 | EDMA_IRQRH[INT48] | eDMA_A channel interrupt 48 |
| 0x0E40 | 228 | EDMA_IRQRH[INT49] | eDMA_A channel interrupt 49 |
| 0x0E50 | 229 | EDMA_IRQRH[INT50] | eDMA_A channel interrupt 50 |
| 0x0E60 | 230 | EDMA_IRQRH[INT51] | eDMA_A channel interrupt 51 |
| 0x0E70 | 231 | EDMA_IRQRH[INT52] | eDMA_A channel interrupt 52 |
| 0x0E80 | 232 | EDMA_IRQRH[INT53] | eDMA_A channel interrupt 53 |
| 0x0E90 | 233 | EDMA_IRQRH[INT54] | eDMA_A channel interrupt 54 |
| 0x0EA0 | 234 | EDMA_IRQRH[INT55] | eDMA_A channel interrupt 55 |
| 0x0EB0 | 235 | EDMA_IRQRH[INT56] | eDMA_A channel interrupt 56 |
| 0x0EC0 | 236 | EDMA_IRQRH[INT57] | eDMA_A channel interrupt 57 |
| 0x0ED0 | 237 | EDMA_IRQRH[INT58] | eDMA_A channel interrupt 58 |
| 0x0EE0 | 238 | EDMA_IRQRH[INT59] | eDMA_A channel interrupt 59 |
| 0x0EF0 | 239 | EDMA_IRQRH[INT60] | eDMA_A channel interrupt 60 |
| 0x0F00 | 240 | EDMA_IRQRH[INT61] | eDMA_A channel interrupt 61 |
| 0x0F10 | 241 | EDMA_IRQRH[INT62] | eDMA_A channel interrupt 62 |
| 0x0F20 | 242 | EDMA_IRQRH[INT63] | eDMA_A channel interrupt 63 |
| eTPU B | | | |
| 0x0F30 | 243 | ETPU_CISR_B[CIS0] | eTPU engine B channel 0 interrupt status |
| 0x0F40 | 244 | ETPU_CISR_B[CIS1] | eTPU engine B channel 1 interrupt status |
| 0x0F50 | 245 | ETPU_CISR_B[CIS2] | eTPU engine B channel 2 interrupt status |
| 0x0F60 | 246 | ETPU_CISR_B[CIS3] | eTPU engine B channel 3 interrupt status |
| 0x0F70 | 247 | ETPU_CISR_B[CIS4] | eTPU engine B channel 4 interrupt status |
| 0x0F80 | 248 | ETPU_CISR_B[CIS5] | eTPU engine B channel 5 interrupt status |
| 0x0F90 | 249 | ETPU_CISR_B[CIS6] | eTPU engine B channel 6 interrupt status |
| 0x0FA0 | 250 | ETPU_CISR_B[CIS7] | eTPU engine B channel 7 interrupt status |
| 0x0FB0 | 251 | ETPU_CISR_B[CIS8] | eTPU engine B channel 8 interrupt status |
| 0x0FC0 | 252 | ETPU_CISR_B[CIS9] | eTPU engine B channel 9 interrupt status |
| 0x0FD0 | 253 | ETPU_CISR_B[CIS10] | eTPU engine B channel 10 interrupt status |
| 0x0FEO | 254 | ETPU_CISR_B[CIS11] | eTPU engine B channel 11 interrupt status |
| 0x0FF0 | 255 | ETPU_CISR_B[CIS12] | eTPU engine B channel 12 interrupt status |

Table 10-8. Interrupt Request Sources (continued)

| Hardware Vector Mode Offset | Vector Number ¹ | Source ² | Description |
|-----------------------------|----------------------------|--|--|
| 0x1000 | 256 | ETPU_CISR_B[CIS13] | eTPU engine B channel 13 interrupt status |
| 0x1010 | 257 | ETPU_CISR_B[CIS14] | eTPU engine B channel 14 interrupt status |
| 0x1020 | 258 | ETPU_CISR_B[CIS15] | eTPU engine B channel 15 interrupt status |
| 0x1030 | 259 | ETPU_CISR_B[CIS16] | eTPU engine B channel 16 interrupt status |
| 0x1040 | 260 | ETPU_CISR_B[CIS17] | eTPU engine B channel 17 interrupt status |
| 0x1050 | 261 | ETPU_CISR_B[CIS18] | eTPU engine B channel 18 interrupt status |
| 0x1060 | 262 | ETPU_CISR_B[CIS19] | eTPU engine B channel 19 interrupt status |
| 0x1070 | 263 | ETPU_CISR_B[CIS20] | eTPU engine B channel 20 interrupt status |
| 0x1080 | 264 | ETPU_CISR_B[CIS21] | eTPU engine B channel 21 interrupt status |
| 0x1090 | 265 | ETPU_CISR_B[CIS22] | eTPU engine B channel 22 interrupt status |
| 0x10A0 | 266 | ETPU_CISR_B[CIS23] | eTPU engine B channel 23 interrupt status |
| 0x10B0 | 267 | ETPU_CISR_B[CIS24] | eTPU engine B channel 24 interrupt status |
| 0x10C0 | 268 | ETPU_CISR_B[CIS25] | eTPU engine B channel 25 interrupt status |
| 0x10D0 | 269 | ETPU_CISR_B[CIS26] | eTPU engine B channel 26 interrupt status |
| 0x10E0 | 270 | ETPU_CISR_B[CIS27] | eTPU engine B channel 27 interrupt status |
| 0x10F0 | 271 | ETPU_CISR_B[CIS28] | eTPU engine B channel 28 interrupt status |
| 0x1100 | 272 | ETPU_CISR_B[CIS29] | eTPU engine B channel 29 interrupt status |
| 0x1110 | 273 | ETPU_CISR_B[CIS30] | eTPU engine B channel 30 interrupt status |
| 0x1120 | 274 | ETPU_CISR_B[CIS31] | eTPU engine B channel 31 interrupt status |
| DSPI A | | | |
| 0x1130 | 275 | DSPI_ASR[TFUF] DSPI_ASR[RFOF] | DSPI A combined overrun interrupt requests: <ul style="list-style-type: none"> • Transmit FIFO underflow • Receive FIFO overflow |
| 0x1140 | 276 | DSPI_ASR[EOQF] | DSPI A transmit FIFO end-of-queue flag |
| 0x1150 | 277 | DSPI_ASR[TFFF] | DSPI_A Tx FIFO fill request flag |
| 0x1160 | 278 | DSPI_ASR[TCF] | DSPI_A transfer complete flag |
| 0x1170 | 279 | DSPI_ASR[RFDF] | DSPI_A Rx FIFO drain request flag |
| FlexCAN B | | | |
| 0x1180 | 280 | CANB_ESR[BOFF_INT] CANB_ESR[TWRN_INT] CANB_ESR[RWRN_INT] | FlexCAN B bus off interrupt FlexCAN B transmit warning interrupt FlexCAN B receive warning interrupt |
| 0x1190 | 281 | CANB_ESR[ERR_INT] | FlexCAN B error interrupt |
| 0x11A0 | 282 | Reserved | |

Table 10-8. Interrupt Request Sources (continued)

| Hardware Vector Mode Offset | Vector Number ¹ | Source ² | Description |
|-----------------------------|----------------------------|--|--|
| 0x11B0 | 283 | CANB_IFRL[BUF0] | FlexCAN B buffer 0 interrupt |
| 0x11C0 | 284 | CANB_IFRL[BUF1] | FlexCAN B buffer 1 interrupt |
| 0x11D0 | 285 | CANB_IFRL[BUF2] | FlexCAN B buffer 2 interrupt |
| 0x11E0 | 286 | CANB_IFRL[BUF3] | FlexCAN B buffer 3 interrupt |
| 0x11F0 | 287 | CANB_IFRL[BUF4] | FlexCAN B buffer 4 interrupt |
| 0x1200 | 288 | CANB_IFRL[BUF5] | FlexCAN B buffer 5 interrupt |
| 0x1210 | 289 | CANB_IFRL[BUF6] | FlexCAN B buffer 6 interrupt |
| 0x1220 | 290 | CANB_IFRL[BUF7] | FlexCAN B buffer 7 interrupt |
| 0x1230 | 291 | CANB_IFRL[BUF8] | FlexCAN B buffer 8 interrupt |
| 0x1240 | 292 | CANB_IFRL[BUF9] | FlexCAN B buffer 9 interrupt |
| 0x1250 | 293 | CANB_IFRL[BUF10] | FlexCAN B buffer 10 interrupt |
| 0x1260 | 294 | CANB_IFRL[BUF11] | FlexCAN B buffer 11 interrupt |
| 0x1270 | 295 | CANB_IFRL[BUF12] | FlexCAN B buffer 12 interrupt |
| 0x1280 | 296 | CANB_IFRL[BUF13] | FlexCAN B buffer 13 interrupt |
| 0x1290 | 297 | CANB_IFRL[BUF14] | FlexCAN B buffer 14 interrupt |
| 0x12A0 | 298 | CANB_IFRL[BUF15] | FlexCAN B buffer 15 interrupt |
| 0x12B0 | 299 | CANB_IFRL[BUF31:BUF16] | FlexCAN B buffers 31–16 interrupts |
| 0x12C0 | 300 | CANB_IFRH[BUF63:BUF32] | FlexCAN B buffers 63–32 interrupts |
| System | | | |
| 0x12D0 | 301 | PIT[0] | |
| 0x12E0 | 302 | PIT[1] | |
| 0x12F0 | 303 | PIT[2] | |
| 0x1300 | 304 | PIT[3] | |
| 0x1310 | 305 | RTI | |
| 0x1320 | 306 | PMC | |
| 0x1330 | 307 | ECC Correction | |
| FlexCAN D | | | |
| 0x1340 | 308 | CAND_ESR[BOFF_INT] CAND_ESR[TWRN_INT] CAND_ESR[RWRN_INT] | FlexCAN D bus off interrupt FlexCAN D transmit warning interrupt FlexCAN D receive warning interrupt |
| 0x1350 | 309 | CAND_ESR[ERR_INT] | FlexCAN D error interrupt |
| 0x1360 | 310 | Reserved | |

Table 10-8. Interrupt Request Sources (continued)

| Hardware Vector Mode Offset | Vector Number ¹ | Source ² | Description |
|-----------------------------|----------------------------|------------------------|------------------------------------|
| 0x1370 | 311 | CAND_IFRL[BUF0] | FlexCAN D buffer 0 interrupt |
| 0x1380 | 312 | CAND_IFRL[BUF1] | FlexCAN D buffer 1 interrupt |
| 0x1390 | 313 | CAND_IFRL[BUF2] | FlexCAN D buffer 2 interrupt |
| 0x13A0 | 314 | CAND_IFRL[BUF3] | FlexCAN D buffer 3 interrupt |
| 0x13B0 | 315 | CAND_IFRL[BUF4] | FlexCAN D buffer 4 interrupt |
| 0x13C0 | 316 | CAND_IFRL[BUF5] | FlexCAN D buffer 5 interrupt |
| 0x13D0 | 317 | CAND_IFRL[BUF6] | FlexCAN D buffer 6 interrupt |
| 0x13E0 | 318 | CAND_IFRL[BUF7] | FlexCAN D buffer 7 interrupt |
| 0x13F0 | 319 | CAND_IFRL[BUF8] | FlexCAN D buffer 8 interrupt |
| 0x1400 | 320 | CAND_IFRL[BUF9] | FlexCAN D buffer 9 interrupt |
| 0x1410 | 321 | CAND_IFRL[BUF10] | FlexCAN D buffer 10 interrupt |
| 0x1420 | 322 | CAND_IFRL[BUF11] | FlexCAN D buffer 11 interrupt |
| 0x1430 | 323 | CAND_IFRL[BUF12] | FlexCAN D buffer 12 interrupt |
| 0x1440 | 324 | CAND_IFRL[BUF13] | FlexCAN D buffer 13 interrupt |
| 0x1450 | 325 | CAND_IFRL[BUF14] | FlexCAN D buffer 14 interrupt |
| 0x1460 | 326 | CAND_IFRL[BUF15] | FlexCAN D buffer 15 interrupt |
| 0x1470 | 327 | CAND_IFRL[BUF31:BUF16] | FlexCAN D buffers 31–16 interrupts |
| 0x1480 | 328 | CAND_IFRH[BUF63:BUF32] | FlexCAN D buffers 63–32 interrupts |
| 0x1490–0x15D0 | 329–349 | Reserved for FlexCAN | |
| FlexRay | | | |
| 0x15E0 | 350 | GIFER[MIF] | FlexRay MIF |
| 0x15F0 | 351 | GIFER[PRIF] | FlexRay PRIF |
| 0x1600 | 352 | GIFER[CHIF] | FlexRay CHIF |
| 0x1610 | 353 | GIFER[WUP_IF] | FlexRay WUP_IF |
| 0x1620 | 354 | GIFER[FBNE_F] | FlexRay FBNE_F |
| 0x1630 | 355 | GIFER[FANE_F] | FlexRay FANE_F |
| 0x1640 | 356 | GIFER[RBIF] | FlexRay RBIF |
| 0x1650 | 357 | GIFER[TBIF] | FlexRay TBIF |
| 0x1660–0x16D0 | 358–365 | Reserved | |
| Decimation Filter B | | | |
| 0x16E0 | 366 | DEC_B | Decimation Filter B input (fill) |

Table 10-8. Interrupt Request Sources (continued)

| Hardware Vector Mode Offset | Vector Number ¹ | Source ² | Description |
|-----------------------------|----------------------------|--|--|
| 0x16F0 | 367 | DEC_B | Decimation Filter B output (drain) |
| 0x1700 | 368 | DEC_B | Decimation Filter B error |
| 0x1710 | 369 | Reserved | |
| 0x1720–0x1890 | 370–393 | Reserved | |
| eQADC_B | | | |
| 0x18A0 | 394 | EQADC_FISR _x [TORF] EQADC_FISR _x [RFOF] EQADC_FISR _x [CFUF] | eQADC B combined overrun interrupt request s from all of the FIFOs: <ul style="list-style-type: none"> • Trigger overrun, • Receive FIFO overflow, • Command FIFO underflow |
| 0x18B0 | 395 | EQADC_FISR0[NCF] | eQADC B command FIFO 6 non-coherency flag |
| 0x18C0 | 396 | EQADC_FISR0[PF] | eQADC B command FIFO 6 pause flag |
| 0x18D0 | 397 | EQADC_FISR0[EOQF] | eQADC B command FIFO 6 command queue end-of-queue flag |
| 0x18E0 | 398 | EQADC_FISR0[CFFF] | eQADC B command FIFO 6 fill flag |
| 0x18F0 | 399 | EQADC_FISR0[RFDF] | eQADC B receive FIFO 6 drain flag |
| 0x1900 | 400 | EQADC_FISR1[NCF] | eQADC B command FIFO 7 non-coherency flag |
| 0x1910 | 401 | EQADC_FISR1[PF] | eQADC B command FIFO 7 pause flag |
| 0x1920 | 402 | EQADC_FISR1[EOQF] | eQADC B command FIFO 7 command queue end-of-queue flag |
| 0x1930 | 403 | EQADC_FISR1[CFFF] | eQADC B command FIFO 7 fill flag |
| 0x1940 | 404 | EQADC_FISR1[RFDF] | eQADC B receive FIFO 7 drain flag |
| 0x1950 | 405 | EQADC_FISR2[NCF] | eQADC B command FIFO 8 non-coherency flag |
| 0x1960 | 406 | EQADC_FISR2[PF] | eQADC B command FIFO 8 pause flag |
| 0x1970 | 407 | EQADC_FISR2[EOQF] | eQADC B command FIFO 8 command queue end-of-queue flag |
| 0x1980 | 408 | EQADC_FISR2[CFFF] | eQADC B command FIFO 8 fill flag |
| 0x1990 | 409 | EQADC_FISR2[RFDF] | eQADC B receive FIFO 8 drain flag |
| 0x19A0 | 410 | EQADC_FISR3[NCF] | eQADC B command FIFO 9 non-coherency flag |
| 0x19B0 | 411 | EQADC_FISR3[PF] | eQADC B command FIFO 9 pause flag |
| 0x19C0 | 412 | EQADC_FISR3[EOQF] | eQADC B command FIFO 9 command queue end-of-queue flag |
| 0x19D0 | 413 | EQADC_FISR3[CFFF] | eQADC B command FIFO 9 fill flag |
| 0x19E0 | 414 | EQADC_FISR3[RFDF] | eQADC B receive FIFO 9 drain flag |
| 0x19F0 | 415 | EQADC_FISR4[NCF] | eQADC B command FIFO 10 non-coherency flag |
| 0x1A00 | 416 | EQADC_FISR4[PF] | eQADC B command FIFO 10 pause flag |
| 0x1A10 | 417 | EQADC_FISR4[EOQF] | eQADC B command FIFO 10 command queue end-of-queue flag |

Table 10-8. Interrupt Request Sources (continued)

| Hardware Vector Mode Offset | Vector Number ¹ | Source ² | Description |
|-----------------------------|----------------------------|----------------------|---|
| 0x1A20 | 418 | EQADC_FISR4[CFFF] | eQADC B command FIFO 10 fill flag |
| 0x1A30 | 419 | EQADC_FISR4[RFDF] | eQADC B receive FIFO 10 drain flag |
| 0x1A40 | 420 | EQADC_FISR5[NCF] | eQADC B command FIFO 11 non-coherency flag |
| 0x1A50 | 421 | EQADC_FISR5[PF] | eQADC B command FIFO 11 pause flag |
| 0x1A60 | 422 | EQADC_FISR5[EOQF] | eQADC B command FIFO 11 command queue end-of-queue flag |
| 0x1A70 | 423 | EQADC_FISR5[CFFF] | eQADC B command FIFO 11 fill flag |
| 0x1A80 | 424 | EQADC_FISR5[RFDF] | eQADC B receive FIFO 11 drain flag |
| eDMA_B | | | |
| 0x1A90 | 425 | EDMA_ERL[ERR31:ERR0] | eDMA_B channel error flags 31–0 |
| 0x1AA0 | 426 | EDMA_IRQRL[INT00] | eDMA_B channel interrupt 0 |
| 0x1AB0 | 427 | EDMA_IRQRL[INT01] | eDMA_B channel interrupt 1 |
| 0x1AC0 | 428 | EDMA_IRQRL[INT02] | eDMA_B channel interrupt 2 |
| 0x1AD0 | 429 | EDMA_IRQRL[INT03] | eDMA_B channel interrupt 3 |
| 0x1AE0 | 430 | EDMA_IRQRL[INT04] | eDMA_B channel interrupt 4 |
| 0x1AF0 | 431 | EDMA_IRQRL[INT05] | eDMA_B channel interrupt 5 |
| 0x1B00 | 432 | EDMA_IRQRL[INT06] | eDMA_B channel interrupt 6 |
| 0x1B10 | 433 | EDMA_IRQRL[INT07] | eDMA_B channel interrupt 7 |
| 0x1B20 | 434 | EDMA_IRQRL[INT08] | eDMA_B channel interrupt 8 |
| 0x1B30 | 435 | EDMA_IRQRL[INT09] | eDMA_B channel interrupt 9 |
| 0x1B40 | 436 | EDMA_IRQRL[INT10] | eDMA_B channel interrupt 10 |
| 0x1B50 | 437 | EDMA_IRQRL[INT11] | eDMA_B channel interrupt 11 |
| 0x1B60 | 438 | EDMA_IRQRL[INT12] | eDMA_B channel interrupt 12 |
| 0x1B70 | 439 | EDMA_IRQRL[INT13] | eDMA_B channel interrupt 13 |
| 0x1B80 | 440 | EDMA_IRQRL[INT14] | eDMA_B channel interrupt 14 |
| 0x1B90 | 441 | EDMA_IRQRL[INT15] | eDMA_B channel interrupt 15 |
| 0x1BA0 | 442 | EDMA_IRQRL[INT16] | eDMA_B channel interrupt 16 |
| 0x1BB0 | 443 | EDMA_IRQRL[INT17] | eDMA_B channel interrupt 17 |
| 0x1BC0 | 444 | EDMA_IRQRL[INT18] | eDMA_B channel interrupt 18 |
| 0x1BD0 | 445 | EDMA_IRQRL[INT19] | eDMA_B channel interrupt 19 |
| 0x1BE0 | 446 | EDMA_IRQRL[INT20] | eDMA_B channel interrupt 20 |
| 0x1BFO | 447 | EDMA_IRQRL[INT21] | eDMA_B channel interrupt 21 |

Table 10-8. Interrupt Request Sources (continued)

| Hardware Vector Mode Offset | Vector Number ¹ | Source ² | Description |
|-----------------------------|----------------------------|---------------------|------------------------------------|
| 0x1C00 | 448 | EDMA_IRQRL[INT22] | eDMA_B channel interrupt 22 |
| 0x1C10 | 449 | EDMA_IRQRL[INT23] | eDMA_B channel interrupt 23 |
| 0x1C20 | 450 | EDMA_IRQRL[INT24] | eDMA_B channel interrupt 24 |
| 0x1C30 | 451 | EDMA_IRQRL[INT25] | eDMA_B channel interrupt 25 |
| 0x1C40 | 452 | EDMA_IRQRL[INT26] | eDMA_B channel interrupt 26 |
| 0x1C50 | 453 | EDMA_IRQRL[INT27] | eDMA_B channel interrupt 27 |
| 0x1C60 | 454 | EDMA_IRQRL[INT28] | eDMA_B channel interrupt 28 |
| 0x1C70 | 455 | EDMA_IRQRL[INT29] | eDMA_B channel interrupt 29 |
| 0x1C80 | 456 | EDMA_IRQRL[INT30] | eDMA_B channel interrupt 30 |
| 0x1C90 | 457 | EDMA_IRQRL[INT31] | eDMA_B channel interrupt 31 |
| 0x1CA0 | 458 | Reserved | |
| eMIOS | | | |
| 0x1CB0 | 459 | EMIOS_GFR[F24] | eMIOS channel 24 flag |
| 0x1CC0 | 460 | EMIOS_GFR[F25] | eMIOS channel 25 flag |
| 0x1CD0 | 461 | EMIOS_GFR[F26] | eMIOS channel 26 flag |
| 0x1CE0 | 462 | EMIOS_GFR[F27] | eMIOS channel 27 flag |
| 0x1CF0 | 463 | EMIOS_GFR[F28] | eMIOS channel 28 flag |
| 0x1D00 | 464 | EMIOS_GFR[F29] | eMIOS channel 29 flag |
| 0x1D10 | 465 | EMIOS_GFR[F30] | eMIOS channel 30 flag |
| 0x1D20 | 466 | EMIOS_GFR[F31] | eMIOS channel 31 flag |
| Decimation Filter C | | | |
| 0x1D30 | 467 | DEC_C | Decimation Filter C input (fill) |
| 0x1D40 | 468 | DEC_C | Decimation Filter C output (drain) |
| 0x1D50 | 469 | DEC_C | Decimation Filter C error |
| Decimation Filter D | | | |
| 0x1D60 | 470 | DEC_D | Decimation Filter D input (fill) |
| 0x1D70 | 471 | DEC_D | Decimation Filter D output (drain) |
| 0x1D80 | 472 | DEC_D | Decimation Filter D error |
| eSCI C | | | |

Table 10-8. Interrupt Request Sources (continued)

| Hardware Vector Mode Offset | Vector Number ¹ | Source ² | Description |
|-----------------------------|----------------------------|---|--|
| 0x1D90 | 473 | ESCIC_SR[TDRE] ESCIC_SR[TC] ESCIC_SR[RDRF] ESCIC_SR[IDLE] ESCIC_SR[OR] ESCIC_SR[NF] ESCIC_SR[FE] ESCIC_SR[PF] ESCIC_SR[BERR] ESCIC_SR[RXRDY] ESCIC_SR[TXRDY] ESCIC_SR[LWAKE] ESCIC_SR[STO] ESCIC_SR[PBERR] ESCIC_SR[CERR] | Combined interrupt requests of eSCI module C: <ul style="list-style-type: none"> • LIN status register 1 • LIN status register 2 • SCI status register 2 • Transmit data register empty • Transmit complete • Receive data register full • Idle line • Overrun • Noise flag • Framing error flag • Parity error flag interrupt requests • Bit error interrupt request • Receive data ready • Transmit data ready • Received LIN wakeup signal • Slave timeout • Physical bus error • CRC error |
| 0x1DA0 | 474 | Reserved | |
| 0x1DB0 | 475 | Reserved | |
| Decimation Filter E–H | | | |
| 0x1DC0 | 476 | DEC_E | Decimation Filter E |
| 0x1DD0 | 477 | DEC_F | Decimation Filter F |
| 0x1DE0 | 478 | DEC_G | Decimation Filter G |
| 0x1DF0 | 479 | DEC_H | Decimation Filter H |

¹ The maximum vector number (479) is used to identify the location of the last available interrupt vector in memory for this device. Because blocks of memory throughout the total memory map are used for other purposes, the maximum vector number does not indicate the total number of available interrupt sources for this device.

² Interrupt requests from the same module location are ORed together.

NOTE

The peripheral or software configurable interrupt request asserts when the PRI_n value in the interrupt priority select register (INTC_PSR n) is greater than the PRI_n value in interrupt current priority register (INTC_CPR).

If an asserted peripheral or software configurable interrupt request negates before the processor acknowledges its request, the interrupt request can reassert and remain asserted. If this occurs, the processor uses the INTC_PSR n value to locate the IRQ vector, and updates the PRI_n value in the INTC_CPR with the PRI_n value in INTC_PSR n .

Clearing the peripheral interrupt request enable bit for the peripheral initiating the request, or setting the IRQ mask bit has the same consequences as clearing its flag bit. Setting its enable bit or clearing its mask bit while its flag bit is asserted has the same effect on the INTC as an interrupt event setting the flag bit.

10.4.1.1 Peripheral Interrupt Requests

An interrupt event in a peripheral's hardware sets a flag bit which resides in that peripheral. The interrupt request from the peripheral is driven by that flag bit.

The time from when the peripheral starts to drive its peripheral interrupt request to the INTC to the time that the INTC starts to drive the interrupt request to the processor is three clocks.

10.4.1.2 Software configurable Interrupt Requests

The software set/clear interrupt registers (INTC_SSCIR_x) support the setting or clearing of software-configurable interrupt requests. These registers contain eight independent sets of bits to set and clear a corresponding flag bit by software. With the exception of being set by software, this flag bit behaves the same as a flag bit set within a peripheral. This flag bit generates an interrupt request within the INTC just like a peripheral interrupt request.

An interrupt request is triggered by software writing a 1 to the SET_n bit in INTC software set/clear interrupt registers (INTC_SSCIR0–INTC_SSCIR7). This write sets a CLR_n flag bit that generates an interrupt request. The interrupt request is cleared by writing a 1 to the CLR_n bit. Specific behavior includes the following:

- Writing a 1 to SET_n leaves SET_n unchanged at 0 but sets the flag bit (CLR_n bit).
- Writing a 0 to SET_n has no effect.
- Writing a 1 to CLR_n clears the flag (CLR_n) bit.
- Writing a 0 to CLR_n has no effect.
- If a 1 is written to a pair of SET_n and CLR_n bits at the same time, the flag (CLR_n) is set, regardless of whether CLR_n was asserted before the write.

The time from the write to the SET_n bit to the time that the INTC starts to drive the interrupt request to the processor is four clocks.

10.4.1.3 Unique Vector for Each Interrupt Request Source

Each peripheral and software configurable interrupt request is assigned a hardwired unique 9-bit vector. Software configurable interrupts 0–7 are assigned vectors 0–7, respectively. The peripheral interrupt requests are assigned vectors 8 to as high as needed to cover all of the peripheral interrupt requests.

10.4.2 Priority Management

The asserted interrupt requests are compared to each other based on their PRIn values in INTC priority select registers (INTC_PSR0–INTC_PSR479). The result of that comparison also is compared to PRI in

INTC current priority register (INTC_CPR). The results of those comparisons are used to manage the priority of the ISR being executed by the processor. The LIFO also assists in managing that priority.

10.4.2.1 Current Priority and Preemption

The priority arbitrator, selector, encoder, and comparator submodules shown in [Figure 10-1](#) are used to compare the priority of the asserted interrupt requests to the current priority. If the priority of any asserted peripheral or software configurable interrupt request is higher than the current priority, then the interrupt request to the processor is asserted. Also, a unique vector for the preempting peripheral or software configurable interrupt request is generated for INTC interrupt acknowledge register (INTC_IACKR), and if in hardware vector mode, for the interrupt vector provided to the processor.

10.4.2.1.1 Priority Arbitrator Submodule

The priority arbitrator submodule compares all the priorities of all of the asserted interrupt requests, both peripheral and software configurable. The output of the priority arbitrator submodule is the highest of those priorities. Also, any interrupt requests which have this highest priority are output as asserted interrupt requests to the request selector submodule.

10.4.2.1.2 Request Selector Submodule

If only one interrupt request from the priority arbitrator submodule is asserted, then it is passed as asserted to the vector encoder submodule. If multiple interrupt requests from the priority arbitrator submodule are asserted, then only the one with the lowest vector is passed as asserted to the vector encoder submodule. The lower vector is chosen regardless of the time order of the assertions of the peripheral or software configurable interrupt requests.

10.4.2.1.3 Vector Encoder Submodule

The vector encoder submodule generates the unique 9-bit vector for the asserted interrupt request from the request selector submodule.

10.4.2.1.4 Priority Comparator Submodule

The priority comparator submodule compares the highest priority output from the priority arbitrator submodule with PRI in INTC_CPR. If the priority comparator submodule detects that this highest priority is higher than the current priority, then it asserts the interrupt request to the processor. This interrupt request to the processor asserts whether this highest priority is raised above the value of PRI in INTC_CPR or the PRI value in INTC_CPR is lowered below this highest priority. This highest priority then becomes the new priority which is written to PRI in INTC_CPR when the interrupt request to the processor is acknowledged. Interrupt requests whose PRI_n in INTC_PSR $_n$ are zero does not cause a preemption because their PRI_n is not higher than PRI in INTC_CPR.

Another function of the priority comparator subblock is to signal an update of the INTC_IACKR_PRC0 and INTC_IACKR_PRC1 with the vector number of the first interrupt that arrives that has a priority higher than the current priority. Once the vector number and priority are captured, they cannot be superseded by a higher priority interrupt until an update of the INTC_CPR_PRC0 or INTC_CPR_PRC1 occurs.

One consequence of the priority comparator design is that once a higher priority interrupt request is captured, it must be acknowledged by the CPU before a subsequent interrupt request of even higher priority can be captured. For example, if the CPU is executing a priority level 1 interrupt, and a priority level 2 interrupt request is captured by the INTC, followed shortly by a priority level 3 interrupt request, the level 2 interrupt must be acknowledged by the CPU before a new level 3 interrupt will be generated.

10.4.2.2 LIFO

The LIFO stores the preempted PRI values from the INTC_CPR. Therefore, because these priorities are stacked within the INTC, if interrupts need to be enabled during the ISR, at the beginning of the interrupt exception handler the PRI value in the INTC_CPR does not need to be loaded from the INTC_CPR and stored onto the context stack. Likewise at the end of the interrupt exception handler, the priority does not need to be loaded from the context stack and stored into the INTC_CPR.

The PRI value in the INTC_CPR is pushed onto the LIFO when the INTC_IACKR is read in software vector mode or the interrupt acknowledge signal from the processor is asserted in hardware vector mode. The priority is popped into PRI in the INTC_CPR whenever the INTC_EOIR is written.

Although the INTC supports 16 priorities, an ISR executing with PRI in the INTC_CPR equal to 15 is not preempted. Therefore, the LIFO supports the stacking of 15 priorities. However, the LIFO is only 14 entries deep. An entry for a priority of 0 is not needed because of how pushing onto a full LIFO and popping an empty LIFO are treated. If the LIFO is pushed 15 or more times than it is popped, the priorities first pushed are overwritten. A priority of 0 is an overwritten priority. However, the LIFO pop zeros if it is popped more times than it is pushed. Therefore, although a priority of 0 was overwritten, it is regenerated with the popping of an empty LIFO.

The LIFO is not memory mapped.

10.4.3 Details on Handshaking with Processor

10.4.3.1 Software Vector Mode Handshaking

10.4.3.1.1 Acknowledging Interrupt Request to Processor

A timing diagram of the interrupt request and acknowledge handshaking in software vector mode, along with the handshaking near the end of the interrupt exception handler, is shown in [Figure 10-14](#). The INTC examines the peripheral and software configurable interrupt requests. When it finds an asserted peripheral or software configurable interrupt request with a higher priority than PRI in INTC current priority register (INTC_CPR), it asserts the interrupt request to the processor. The INTVEC field in INTC interrupt acknowledge register (INTC_IACKR) is updated with the preempting interrupt request's vector when the interrupt request to the processor is asserted. The INTVEC field retains that value until the next time the interrupt request to the processor is asserted. The rest of the handshaking is described in [Section 10.1.4.1, Software Vector Mode](#).

10.4.3.1.2 End-of-Interrupt Exception Handler

Before the interrupt exception handling completes, INTC end-of-interrupt register (INTC_EOIR) must be written. When it is written, the LIFO is popped so that the preempted priority is restored into PRI of the INTC_CPR. Before it is written, the peripheral or software configurable flag bit must be cleared so that the peripheral or software configurable interrupt request is negated.

NOTE

To ensure proper operation across all Power Architecture MCUs, execute an MBAR or MSYNC instruction between the access to clear the flag bit and the write to the INTC_EOIR.

When returning from the preemption, the INTC does not search for the peripheral or software configurable interrupt request whose ISR was preempted. Depending on how much the ISR progressed, that interrupt request can no longer be asserted. When PRI in INTC_CPR is lowered to the priority of the preempted ISR, the interrupt request for the preempted ISR or any other asserted peripheral or software configurable interrupt request at or below that priority does not cause a preemption. Instead, after the restoration of the preempted context, the processor returns to the instruction address that it was to next execute before it was preempted. This next instruction is part of the preempted ISR or the interrupt exception handler’s prolog or epilog.

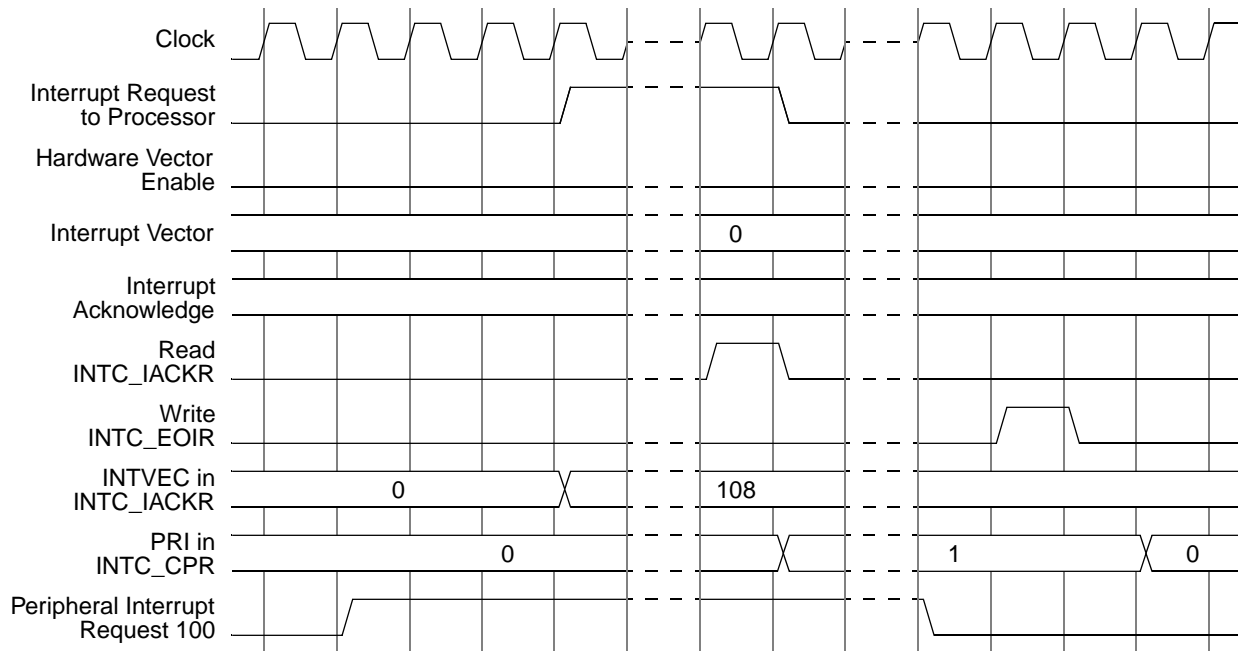

Figure 10-14. Software Vector Mode Handshaking Timing Diagram

10.4.3.2 Hardware Vector Mode Handshaking

A timing diagram of the interrupt request and acknowledge handshaking in hardware vector mode, along with the handshaking near the end of the interrupt exception handler, is shown in Figure 10-15. As in software vector mode, the INTC examines the peripheral and software configurable interrupt requests, and when it finds an asserted one with a higher priority than PRI in INTC_CPR, it asserts the interrupt request

to the processor. The INTVEC field in the INTC_IACKR is updated with the preempting peripheral or software configurable interrupt request's vector when the interrupt request to the processor is asserted. The INTVEC field retains that value until the next time the interrupt request to the processor is asserted. In addition, the value of the interrupt vector to the processor matches the value of the INTVEC field in the INTC_IACKR. The rest of the handshaking is described in [Section 10.1.4.2, Hardware Vector Mode](#).

The handshaking near the end of the interrupt exception handler, that is the writing to the INTC_EOIR, is the same as in software vector mode. Refer to [Section 10.4.3.1.2, End-of-Interrupt Exception Handler](#).

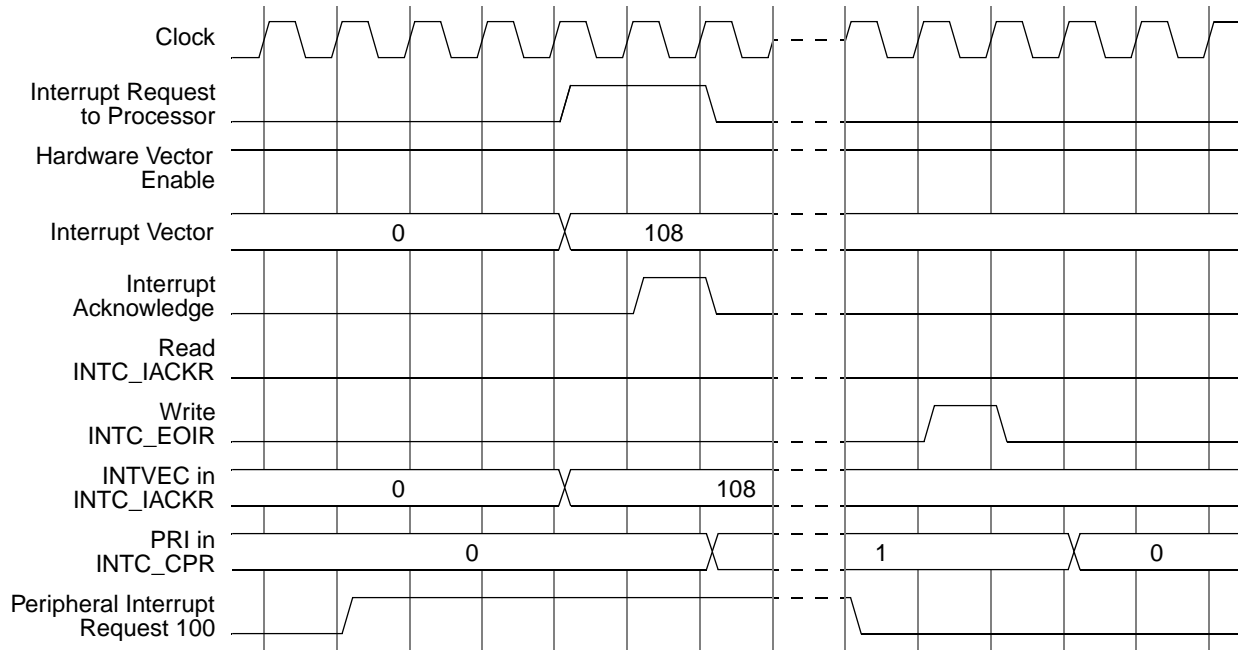

Figure 10-15. Hardware Vector Mode Handshaking Timing Diagram

10.5 Initialization and Application Information

10.5.1 Initialization Flow

After exiting reset, all of the PRI_n fields in INTC priority select registers (INTC_PSR0–INTC_PSR479) is zero, and PRI in INTC current priority register (INTC_CPR) is 15. These reset values prevent the INTC from asserting the interrupt request to the processor. The enable or mask bits in the peripherals are reset such that the peripheral interrupt requests are negated.

An initialization sequence that allows the peripheral and software configurable interrupt requests to generate an interrupt request to the processor is:

```
interrupt_request_initialization:
configure VTES and HVEN in INTC_MCR
configure VTBA in INTC_IACKR
raise the  $PRI_n$  fields in INTC_PSR $n$ 
set the enable bits or clear the mask bits for the peripheral interrupt requests
lower PRI in INTC_CPR to zero
enable processor recognition of interrupts
```

10.5.2 Interrupt Exception Handler

These example interrupt exception handlers use Power Architecture assembly code.

10.5.2.1 Software Vector Mode

```

interrupt_exception_handler:
code to create stack frame, save working register, and save SRR0 and SRR1

lis      r3,INTC_IACKR@ha      # form adjusted upper half of INTC_IACKR address
lwz     r3,INTC_IACKR@l(r3)   # load INTC_IACKR, which clears request to processor
lwz     r3,0x0(r3)           # load address of ISR from vector table
wrteei  1                     # enable processor recognition of interrupts

code to save rest of context required by e500 EABI

mtrlr   r3                    # move the INTC_IACKR address into the link register
blrl                                         # branch to ISR; link register updated with epilg
                                         # address

epilog:
code to restore most of context required by e500 EABI

# Popping the LIFO after the restoration of most of the context and the disabling of processor
# recognition of interrupts eases the calculation of the maximum stack depth at the cost of
# postponing the servicing of the next interrupt request.
mbar                                         # ensure store to clear flag bit has completed
lis     r3,INTC_EOIR@ha      # form adjusted upper half of INTC_EOIR address
li      r4,0x0               # form 0 to write to INTC_EOIR
wrteei  0                     # disable processor recognition of interrupts
stw     r4,INTC_EOIR@l(r3)   # store to INTC_EOIR, informing INTC to lower priority

code to restore SRR0 and SRR1, restore working registers, and delete stack frame

rfi

vector_table_base_address:
address of ISR for interrupt with vector 0
address of ISR for interrupt with vector 1
.
.
.
address of ISR for interrupt with vector 510
address of ISR for interrupt with vector 511

ISRx:
code to service the interrupt event
code to clear flag bit which drives interrupt request to INTC

blr                                         # return to epilg

```

10.5.2.2 Hardware Vector Mode

This interrupt exception handler is useful with processor and system bus implementations that support a hardware vector. In this example, each `interrupt_exception_handlerx` has space for only four instructions, and therefore a branch to `interrupt_exception_handler_continuedx` is needed.

```

interrupt_exception_handlerx:
b          interrupt_exception_handler_continuedx# 4 instructions available, branch to continue

interrupt_exception_handler_continuedx:
code to create stack frame, save working register, and save SRR0 and SRR1

wrteei    1                                # enable processor recognition of interrupts

code to save rest of context required by e500 EABI

bl        ISRx                             # branch to ISR for interrupt with vector x

epilog:
code to restore most of context required by e500 EABI

# Popping the LIFO after the restoration of most of the context and the disabling of processor
# recognition of interrupts eases the calculation of the maximum stack depth at the cost of
# postponing the servicing of the next interrupt request.
mbar                                           # ensure store to clear flag bit has completed
lis      r3,INTC_EOIR@ha                      # form adjusted upper half of INTC_EOIR address
li       r4,0x0                               # form 0 to write to INTC_EOIR
wrteei    0                                # disable processor recognition of interrupts
stw      r4,INTC_EOIR@l(r3)                  # store to INTC_EOIR, informing INTC to lower priority

code to restore SRR0 and SRR1, restore working registers, and delete stack frame

rfi

ISRx:
code to service the interrupt event
code to clear flag bit which drives interrupt request to INTC

blr                                           # branch to epilog
    
```

10.5.3 ISR, RTOS, and Task Hierarchy

The RTOS and all of the tasks under its control typically execute with PRI in INTC current priority register (INTC_CPR) having a value of 0. The RTOS execute the tasks according to whatever priority scheme that it has, but that priority scheme is independent and has a lower priority of execution than the priority scheme of the INTC. In other words, the ISRs execute above INTC_CPR priority 0 and outside the control of the RTOS, the RTOS executes at INTC_CPR priority 0, and while the tasks execute at different priorities under the control of the RTOS, they also execute at INTC_CPR priority 0.

If a task shares a resource with an ISR and the PCP is being used to manage that shared resource, then the task's priority can be elevated in the INTC_CPR while the shared resource is being accessed.

An ISR whose PRI_n in INTC priority select registers (INTC_PSR0–INTC_PSR479) has a value of 0 does not cause an interrupt request to the processor, even if its peripheral or software configurable interrupt request is asserted. For a peripheral interrupt request, not setting its enable bit or disabling the mask bit causes it to remain negated, which consequently also does not cause an interrupt request to the processor. Since the ISRs are outside the control of the RTOS, this ISR does not run unless called by another ISR or the interrupt exception handler, perhaps after executing another ISR.

10.5.4 Order of Execution

An ISR with a higher priority can preempt an ISR with a lower priority, regardless of the unique vectors associated with each of their peripheral or software configurable interrupt requests. However, if multiple peripheral or software configurable interrupt requests are asserted, more than one has the highest priority, and that priority is high enough to cause preemption, the INTC selects the one with the lowest unique vector regardless of the order in time that they asserted. However, the ability to meet deadlines with this scheduling scheme is no less than if the ISRs execute in the time order that their peripheral or software configurable interrupt requests asserted.

The example in [Table 10-9](#) shows the order of execution of both ISRs with different priorities, and with the same priority.

Table 10-9. Order of ISR Execution Example

| Step | Step Description | Code Executing At End of Step | | | | | Interrupt Exception Handler | PRI in INTC_CPR at End of Step |
|------|---|-------------------------------|---------------------|--------|--------|--------|-----------------------------|--------------------------------|
| | | RTOS | ISR108 ¹ | ISR208 | ISR308 | ISR408 | | |
| 1 | RTOS at priority 0 is executing. | X | | | | | | 0 |
| 2 | Peripheral interrupt request 100 at priority 1 asserts. Interrupt taken. | | X | | | | | 1 |
| 3 | Peripheral interrupt request 400 at priority 4 asserts. Interrupt taken. | | | | | X | | 4 |
| 4 | Peripheral interrupt request 300 at priority 3 asserts. | | | | | X | | 4 |
| 5 | Peripheral interrupt request 200 at priority 3 asserts. | | | | | X | | 4 |
| 6 | ISR408 completes. Interrupt exception handler writes to INTC_EOIR. | | | | | | X | 1 |
| 7 | Interrupt taken. ISR208 starts to execute, even though peripheral interrupt request 300 asserted first. | | | X | | | | 3 |
| 8 | ISR208 completes. Interrupt exception handler writes to INTC_EOIR. | | | | | | X | 1 |
| 9 | Interrupt taken. ISR308 starts to execute. | | | | X | | | 3 |

Table 10-9. Order of ISR Execution Example (continued)

| Step | Step Description | Code Executing At End of Step | | | | | | PRI in INTC_CPR at End of Step |
|------|--|-------------------------------|---------------------|--------|--------|--------|-----------------------------|--------------------------------|
| | | RTOS | ISR108 ¹ | ISR208 | ISR308 | ISR408 | Interrupt Exception Handler | |
| 10 | ISR308 completes. Interrupt exception handler writes to INTC_EOIR. | | | | | | X | 1 |
| 11 | ISR108 completes. Interrupt exception handler writes to INTC_EOIR. | | | | | | X | 0 |
| 12 | RTOS continues execution. | X | | | | | | 0 |

¹ ISR108 executes for peripheral interrupt request 100 because the first eight ISRs are for software configurable interrupt requests.

10.5.5 Priority Ceiling Protocol

10.5.5.1 Elevating Priority

The PRI field in INTC current priority register (INTC_CPR) is elevated in the OSEK PCP to the ceiling of all of the priorities of the ISRs that share a resource. This protocol therefore allows coherent accesses of the ISRs to that shared resource.

For example, ISR1 has a priority of 1, ISR2 has a priority of 2, and ISR3 has a priority of 3. They all share the same resource. Before ISR1 or ISR2 can access that resource, they must raise the PRI value in INTC_CPR to 3, the ceiling of all of the ISR priorities. After they release the resource, the PRI value in INTC_CPR can be lowered. If they do not raise their priority, then ISR2 can preempt ISR1, and ISR3 can preempt ISR1 or ISR2, possibly corrupting the shared resource. Another possible failure mechanism is deadlock if the higher priority ISR needs the lower priority ISR to release the resource before it can continue, but the lower priority ISR can not release the resource until the higher priority ISR completes and execution returns to the lower priority ISR.

Using the PCP instead of disabling processor recognition of all interrupts eliminates the time when accessing a shared resource that all higher priority interrupts are blocked. For example, while ISR3 cannot preempt ISR1 while it is accessing the shared resource, all of the ISRs with a priority higher than 3 can preempt ISR1.

10.5.5.2 Ensuring Coherency

10.5.5.2.1 Interrupt with Blocked Priority

Non-coherent accesses to a shared resource can occur. As an example, ISR1 and ISR2 both share a resource. ISR1 has a lower priority, therefore it executes and then writes the new PRI value in the current priority register (INTC_CPR). The next instruction writes a value to a shared coherent data block.

If INTC asserts the ISR2 interrupt request to the processor just before or at the same time as the first ISR1 write, it is possible for both the ISR1 and ISR2 writes to execute while the processor responds to the INTC

request, discards the transactions, and flushes the processing pipeline. However, ISR2 cannot access the data block coherently because the data block is now corrupted.

OSEK uses the GetResource and ReleaseResource system services to manage access to a shared resource. To prevent corrupting a coherent data block, use the following code to modify the PRI in INTC_CPR. Interrupts must be enabled before executing the following GetResource code sequence:

```
GetResource:
raise PRI
mbar
isync

ReleaseResource:
mbar
lower PRI
```

10.5.5.2.2 Raised Priority Preserved

Before the instruction after the GetResource system service executes, all pending transactions have completed. These pending transactions can include an ISR for a peripheral or software settable interrupt request whose priority was equal to or lower than the raised priority. Also, during the epilog of the interrupt exception handler for this preempting ISR, the raised priority has been restored from the LIFO to PRI in INTC_CPR. The shared coherent data block now can be accessed coherently. [Figure 10-16](#) shows the timing diagram for this scenario, and [Table 10-10](#) explains the events. The example is for software vector mode, but except for the method of retrieving the vector and acknowledging the interrupt request to the processor, hardware vector mode is identical.

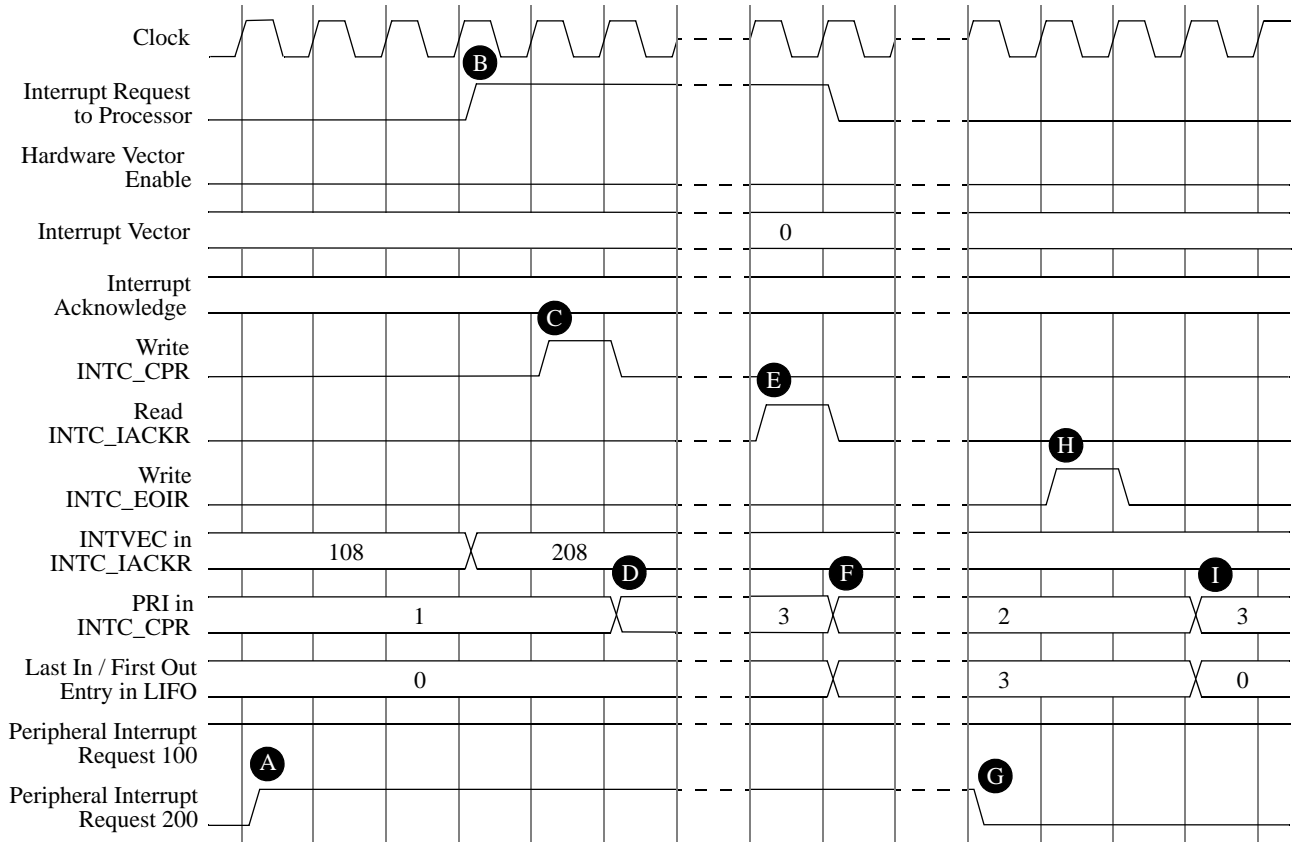

Figure 10-16. Raised Priority Preserved Timing Diagram

Table 10-10. Raised Priority Preserved Events

| Event | Description |
|-------|--|
| A | Peripheral interrupt request 200 asserts during execution of ISR108 running at priority 1. |
| B | Interrupt request to processor asserts. INTVEC in INTC_IACKR updates with vector for that peripheral interrupt request. |
| C | ISR108 writes to INTC_CPR to raise priority to 3 before accessing shared coherent data block. |
| D | PRI in INTC_CPR now at 3, reflecting the write. This write, just before accessing data block, is the last instruction the processor executes before being interrupted. |
| E | Interrupt exception handler prolog acknowledges interrupt by reading INTC_IACKR. |
| F | PRI of 3 pushed onto LIFO. PRI in INTC_CPR updates to 2, the priority of ISR208. |
| G | ISR208 clears its flag bit, deasserting its peripheral interrupt request. |
| H | Interrupt exception handler epilg writes to INTC_EOIR. |
| I | LIFO pops 3, restoring the raised priority onto PRI in INTC_CPR. Next value to pop from LIFO is the priority from before peripheral interrupt request 100 interrupted. ISR108 now can access data block coherently after interrupt exception handler executes rfi instruction. |

10.5.6 Selecting Priorities According to Request Rates and Deadlines

The selection of the priorities for the ISRs can be made using rate monotonic scheduling (RMS) or a superset of it, deadline monotonic scheduling (DMS). In RMS, the ISRs which have higher request rates have higher priorities. In DMS, if the deadline is before the next time the ISR is requested, then the ISR is assigned a priority according to the time from the request for the ISR to the deadline, not from the time of the request for the ISR to the next request for it.

For example, ISR1 executes every 100 μ s, ISR2 executes every 200 μ s, and ISR3 executes every 300 μ s. ISR1 has a higher priority than ISR2 which has a higher priority than ISR3. However, if ISR3 has a deadline of 150 μ s, then it has a higher priority than ISR2.

The INTC has 16 priorities, which can be much less than the number of ISRs. In this case, group the ISRs with other ISRs that have similar deadlines. For example, when a priority is allocated for every time the request rate doubles: ISRs with request rates around 1 ms share a priority; ISRs with request rates around 500 μ s share a priority; ISRs with request rates around 250 μ s share a priority, etc. With this approach, a range of ISR request rates of 2^{16} can be covered, regardless of the number of ISRs.

Reducing the number of priorities does reduce the processor's ability to meet its deadlines. However, it also allows easier management of ISRs with similar deadlines that share a resource. They do not need to use the PCP to access the shared resource.

10.5.7 Software configurable Interrupt Requests

The software configurable interrupt requests can be used in two ways. They can be used to schedule a lower priority portion of an ISR and for processors to interrupt other processors in a multiple processor system.

10.5.7.1 Scheduling a Lower Priority Portion of an ISR

A portion of an ISR needs to be executed at the PRI_n value in INTC priority select registers (INTC_PSR0–INTC_PSR479), which becomes the PRI value in INTC current priority register (INTC_CPR) with the interrupt acknowledgement. The ISR, however, can have a portion of it which does not need to be executed at this higher priority. Therefore, executing this later portion which does not need to be executed at this higher priority can prevent the execution of ISRs which do not have a higher priority than the earlier portion of the ISR but do have a higher priority than what the later portion of the ISR needs. This preemptive scheduling inefficiency reduces the processor's ability to meet its deadlines.

One option is for the ISR to complete the earlier higher priority portion, but then schedule through the RTOS a task to execute the later lower priority portion. However, some RTOSs can require a large amount of time for an ISR to schedule a task. Therefore, a second option is for the ISR, after completing the higher priority portion, to set a SET_n bit in INTC software set/clear interrupt registers (INTC_SSCIR0–INTC_SSCIR7). Writing a 1 to SET_n causes a software configurable interrupt request. This software configurable interrupt request, which usually has a lower PRI_n value in the INTC_PSR n , therefore does not cause preemptive scheduling inefficiencies.

After generating a software configurable interrupt request, the higher priority ISR completes. The lower priority ISR is scheduled according to its priority. Execution of the higher priority ISR is not resumed after the completion of the lower priority ISR.

10.5.7.2 Scheduling an ISR on Another Processor

Since the $SETn$ bits in the $INTC_SSCIRn$ are memory mapped, processors in multiple processor systems can schedule ISRs on the other processors. One application is that one processor simply wants to command another processor to perform a piece of work, and the initiating processor does not need to use the results of that work. If the initiating processor is concerned that processor executing the software configurable ISR has not completed the work before asking it to again execute that ISR, it can check if the corresponding $CLRn$ bit in $INTC_SSCIRn$ is asserted before again writing a 1 to the $SETn$ bit.

Another application is the sharing of a block of data. For example, a first processor has completed accessing a block of data and wants a second processor to then access it. Furthermore, after the second processor has completed accessing the block of data, the first processor again wants to access it. The accesses to the block of data must be done coherently. The procedure is that the first processor writes a 1 to a $SETn$ bit on the second processor. The second processor, after accessing the block of data, clears the corresponding $CLRn$ bit and then writes 1 to a $SETn$ bit on the first processor, informing it that it now can access the block of data.

10.5.8 Lowering Priority Within an ISR

In implementations without the software-configurable interrupt requests in the INTC software set/clear interrupt registers ($INTC_SSCIR0$ – $INTC_SSCIR7$), a way — besides scheduling a task through an RTOS — to prevent preemptive scheduling inefficiencies with an ISR whose work spans multiple priorities (as described in [Section 10.5.7.1, Scheduling a Lower Priority Portion of an ISR](#)) is to lower the current priority. However, the INTC has a LIFO whose depth is determined by the number of priorities.

NOTE

Lowering the PRI value in INTC current priority register ($INTC_CPR$) within an ISR to below the ISR's corresponding PRI value in INTC priority select registers ($INTC_PSR0$ – $INTC_PSR479$) allows more preemptions than the depth of the LIFO can support.

Therefore, through its use of the LIFO the INTC does not support lowering the current priority within an ISR as a way to avoid preemptive scheduling inefficiencies.

10.5.9 Negating an Interrupt Request Outside of its ISR

10.5.9.1 Negating an Interrupt Request as a Side Effect of an ISR

Some peripherals have flag bits which can be cleared as a side effect of servicing a peripheral interrupt request. For example, reading a specific register can clear the flag bits, and consequently their corresponding interrupt requests too. This clearing as a side effect of servicing a peripheral interrupt request can cause the negation of other peripheral interrupt requests besides the peripheral interrupt request

whose ISR presently is executing. This negating of a peripheral interrupt request outside of its ISR can be a desired effect.

10.5.9.2 Negating Multiple Interrupt Requests in One ISR

An ISR can clear other flag bits besides its own flag bit. One reason that an ISR clears multiple flag bits is because it serviced those other flag bits, and therefore the ISRs for these other flag bits do not need to be executed.

10.5.9.3 Proper Setting of Interrupt Request Priority

Whether an interrupt request negates outside of its own ISR due to the side effect of an ISR execution or the intentional clearing a flag bit, the priorities of the peripheral or software configurable interrupt requests for these other flag bits must be selected properly. Their PRI_n values in INTC priority select registers (INTC_PSR0–INTC_PSR479) must be selected to be at or lower than the priority of the ISR that cleared their flag bits. Otherwise, those flag bits still can cause the interrupt request to the processor to assert. Furthermore, the clearing of these other flag bits also has the same timing relationship to the writing to INTC end-of-interrupt register (INTC_EOIR) as the clearing of the flag bit that caused the present ISR to be executed. Refer to [Section 10.4.3.1.2, End-of-Interrupt Exception Handler](#), for more information.

A flag bit whose enable bit or mask bit is negating its peripheral interrupt request can be cleared at any time, regardless of the peripheral interrupt request's PRI_n value in INTC_PSR n .

10.5.10 Examining LIFO contents

Normally you do not need to know the contents of the LIFO, or even how deep the LIFO is nested. Although the LIFO contents are not memory mapped, you can read the contents by popping the LIFO and reading the PRI field in the INTC current priority register (INTC_CPR). Disabling processor recognition of interrupts while examining the LIFO contents provides a coherent view of the preempted priorities.

The code sequence is:

```
pop_lifo:
store to INTC_EOIR
load INTC_CPR, examine PRI, and store onto stack
if PRI is not zero or value when interrupts were enabled, branch to pop_lifo
```

When you are finished examining the LIFO contents, you can restore it in software vector mode using the following code sequence. In hardware vector mode, reading the INTC_IACKR does not push the INTC_CPR[PRI] onto the LIFO, therefore the LIFO contents cannot be restored in hardware vector mode.

```
push_lifo:
load stacked PRI value and store to INTC_CPR
load INTC_IACKR
if stacked PRI values are not depleted, branch to push_lifo
```

NOTE

Reading the INTC_IACKR acknowledges the interrupt request to the processor and updates the INTC_CPR[PRI] with the priority of the preempting interrupt request. If the processor recognition of interrupts is disabled during the LIFO restoration, interrupt requests to the processor can go undetected. However, since the peripheral or software configurable interrupt requests are not cleared, the peripheral interrupt request to the processor re-asserts when INTC_CPR[PRI] is lower than the priorities of those peripheral or software configurable interrupt requests.

Chapter 11

General-Purpose Static RAM (SRAM)

11.1 Introduction

The SRAM provides 256 KB of general-purpose static RAM (SRAM). The first 32 KB of SRAM is powered by a separate power supply pin for standby operation. [Figure 11-1](#) shows the internal SRAM block diagram.

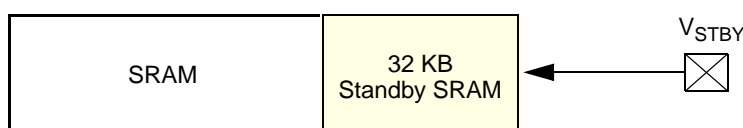

Figure 11-1. Internal SRAM Block Diagram

The SRAM controller has these features:

- Read/write accesses can map to SRAM from any master
- 32 KB with a separate power source for standby operation
- Byte, halfword, word, and doubleword addressable
- 8-bit ECC

11.2 SRAM Operating Modes

[Table 11-1](#) lists and describes the SRAM operating modes.

Table 11-1. SRAM Operating Modes

| Mode | Description |
|---------------------|--|
| Normal (functional) | Allows reads and writes of SRAM. |
| Standby | Preserves the 32 KB of standby memory when the V_{DD} (1.5 V) power drops below the level of V_{STBY} (0.8–1.2 V). Updates to standby SRAM are inhibited during system reset or during standby mode. |

11.3 External Signal Description

The external signal for SRAM is the V_{STBY} RAM power supply. If the standby feature of the SRAM is not used, tie the V_{STBY} pin to V_{SS} .

11.4 Register Memory Map

The SRAM occupies 256 KB of memory starting at the base address as shown in [Table 11-2](#).

Table 11-2. SRAM Memory Map

| Address | Register Name | Register Description | Size |
|--------------------|---------------|-----------------------------------|--------|
| Base (0x4000_0000) | — | SRAM powered by V _{STBY} | 32 KB |
| Base + 0x8000 | — | 224-KB RAM | 224 KB |

The internal SRAM has no registers. Registers for the SRAM ECC are located in the ECSM. See [Chapter 17, Error Correction Status Module \(ECSM\)](#), for more information.

11.5 Functional Description

ECC checks are performed during the read portion of an SRAM ECC read/write (R/W) operation, and ECC calculations are performed during the write portion of a read/write (R/W) operation. Because the ECC bits can contain random data after the device is powered on, you must initialize the SRAM by executing 64-bit write instructions to the entire SRAM. For more information, see [Section 11.7, Initialization and Application Information](#).

11.6 SRAM ECC Mechanism

The SRAM ECC detects the following conditions and produces the following results:

- Detects and corrects all 1-bit errors
- Detects and flags all 2-bit errors as non-correctable errors
- Detects 72-bit reads (64-bit data bus plus the 8-bit ECC) that return all zeros or all ones, asserts an error indicator on the bus cycle, and sets the error flag

SRAM does not detect all errors greater than 2 bits. Internal SRAM writes are done on byte boundaries:

- 1 byte (0:7 bits)
- 2 bytes (0:15 bits)
- 4 bytes or 1 word (0:31 bits)
- 8 bytes or 2 words (0:63 bits)

If the entire 64 data bits are written to SRAM, no read operation is performed and the ECC is calculated across the 64-bit data bus. The 8-bit ECC is appended to the data segment and written to SRAM. If the write operation is less than the entire 64-bit data width (1-, 2-, or 4-byte segment), the following occurs:

1. The ECC mechanism checks the entire 64-bit data bus for errors, detecting and either correcting or flagging errors.
2. The write data bytes (1-, 2-, or 4-byte segment) are merged with the corrected 64 bits on the data bus.
3. The ECC is then calculated on the resulting 64 bits formed in the previous step.
4. The 8-bit ECC result is appended to the 64 bits from the data bus, and the 72-bit value is then written to SRAM.

11.6.1 Access Timing

The system bus is a two-stage pipelined bus, which makes the timing of any access dependent on the access during the previous clock. [Table 11-3](#) lists the various combinations of read and write operations to SRAM and the number of wait states used for the each operation. The table columns contain the following information:

- Current operation Lists the type of SRAM operation executing currently
- Previous operation Lists the valid types of SRAM operations that can precede the current SRAM operation (valid operation during the preceding clock)
- Wait states Lists the number of wait states (bus clocks) the operation requires which depends on the combination of the current and previous operation

Table 11-3. Number of Wait States Required for SRAM Operations

| | Current Operation | Previous Operation | Number of Wait States Required | |
|----------------|-------------------|--------------------------|--|--------------------------------------|
| Read Operation | Read | Idle | 1 | |
| | | Pipelined read | | |
| | | Burst read | | |
| | | 64-bit write | 2 | |
| | | 8-, 16-, or 32-bit write | 0 (read from the same address) | |
| | | | | 1 (read from a different address) |
| | Pipelined read | Read | 0 | |
| | Burst read | Idle | 1,0,0,0 | |
| | | Pipelined read | | |
| | | Burst read | | |
| | | 64-bit write | 2,0,0,0 | |
| | | 8-, 16-, or 32-bit write | 0,0,0,0 (read from the same address) | |
| | | | 1,0,0,0 (read from a different address) | |

Table 11-3. Number of Wait States Required for SRAM Operations (continued)

| | Current Operation | Previous Operation | Number of Wait States Required |
|------------------------|------------------------------------|------------------------------------|----------------------------------|
| Write Operation | 8-, 16-, or 32-bit write | Idle | 1 |
| | | Read | |
| | | Pipelined 8-, 16-, or 32-bit write | 2 |
| | | 64-bit write | |
| | | 8-, 16-, or 32-bit write | 0 (write to the same address) |
| | Pipelined 8-, 16-, or 32-bit write | 8-, 16-, or 32-bit write | 0 |
| | 64-bit write | Idle | 0 |
| | | 64-bit write | |
| | | Read | |
| | 64-bit burst write | Idle | 0,0,0,0 |
| | | 64-bit write | |
| | | Read | |

11.6.2 Reset Effects on SRAM Accesses

If a reset event asserts during a read or write operation to SRAM, the completion of that access depends on the cycle at which the reset occurs. Data read from or written to SRAM before the reset event occurred is retained, and no other address locations are accessed or changed.

If the system SRAM is cached, cache lines can retain indeterminate data that is not written to memory unless the region is set for write-through mode.

NOTE

Standby memory can contain the previous data values if a reset occurs while cache is running in copy back mode.

11.7 Initialization and Application Information

To use the SRAM, the ECC must check all bits that require initialization after power on. Use a 64-bit cache-inhibited write to each SRAM location to initialize the SRAM array as part of the application initialization code. All writes must specify an even number of registers performed on 64-bit word-aligned boundaries. If the write is not the entire 64-bits (8-, 16-, or 32-bits), a read / modify / write operation is generated that checks the ECC value upon the read. See [Section 11.6, SRAM ECC Mechanism](#).

NOTE

You *must* initialize SRAM, even if the application does not use ECC reporting.

11.7.1 Example Code

To initialize SRAM correctly, use a store multiple word (**stmw**) instruction to implement 64-bit writes to all SRAM locations. The **stmw** instruction concatenates two 32-bit registers to implement a single 64-bit write. To ensure the writes are 64-bits, specify an even number of registers and write on 64-bit word-aligned boundaries.

The following example code illustrates the use of the **stmw** instruction to initialize the SRAM ECC bits.

```
init_RAM:
lis      r11,0x4000      # base address of the SRAM, 64-bit word aligned
ori      r11,r11,0      # not needed for this address but could be for others
li       r12,2048       # loop counter to get all of SRAM;
                        # 256*1024/4 bytes/32 GPRs =2048

mtctr    r12
init_ram_loop:
stmw     r0,0(r11)      # write all 32 GPRs to SRAM
addi     r11,r11,128    # inc the ram ptr; 32 GPRs * 4 bytes = 128
bdnz    init_ram_loop  # loop for 256K of SRAM
blr      # done
```



Chapter 12

Flash Memory Array and Control

12.1 Introduction

This section presents information about the following components on this device:

- The flash memory blocks
- The flash memory controller

The primary function of the flash memory module is to serve as electrically programmable and erasable non-volatile memory. The NVM memory can be used for instruction and data storage.

The flash memory module contains two physical arrays (Flash_A and Flash_B) that are organized to provide a contiguous address range for program code and data. Each flash array has three address spaces: low-address space, mid-address space, and high-address space that are subdivided into blocks as shown in [Figure 12-1](#).

| | Flash_A array blocks 128-bits wide | Flash_B array blocks 128-bits wide |
|---|---------------------------------------|---------------------------------------|
| Low address space 256KB (128 bits wide) | 8 x16 KB + 2 x 64 KB | |
| Mid address space 256KB (128 bits wide) | 2 x128 KB | |
| Low address space 256KB (128 bits wide) | | 1 x 256 KB |
| Mid address space 256KB (128 bits wide) | | 1 x 256 KB |
| High address space 3MB (256 bits wide) | 1 x 256 KB | 1 x 256 KB |
| | 1 x 256 KB | 1 x 256 KB |
| | 1 x 256 KB | 1 x 256 KB |
| | 1 x 256 KB | 1 x 256 KB |
| | 1 x 256 KB | 1 x 256 KB |
| | 1 x 256 KB | 1 x 256 KB |

Note: The first 16 bytes of every 32-byte aligned row fall in Array A and the last 16 bytes fall in array B.

Figure 12-1. Flash Segmentation

12.1.1 Block Diagram

12.1.1.1 Flash Memory Module

Figure 12-3 shows a block diagram of the flash memory module. Program execution and data fetches from the Flash module are performed through the FBIU. Control and status registers, used for flash memory reprogramming purposes are accessed through PBRIDGE_A.

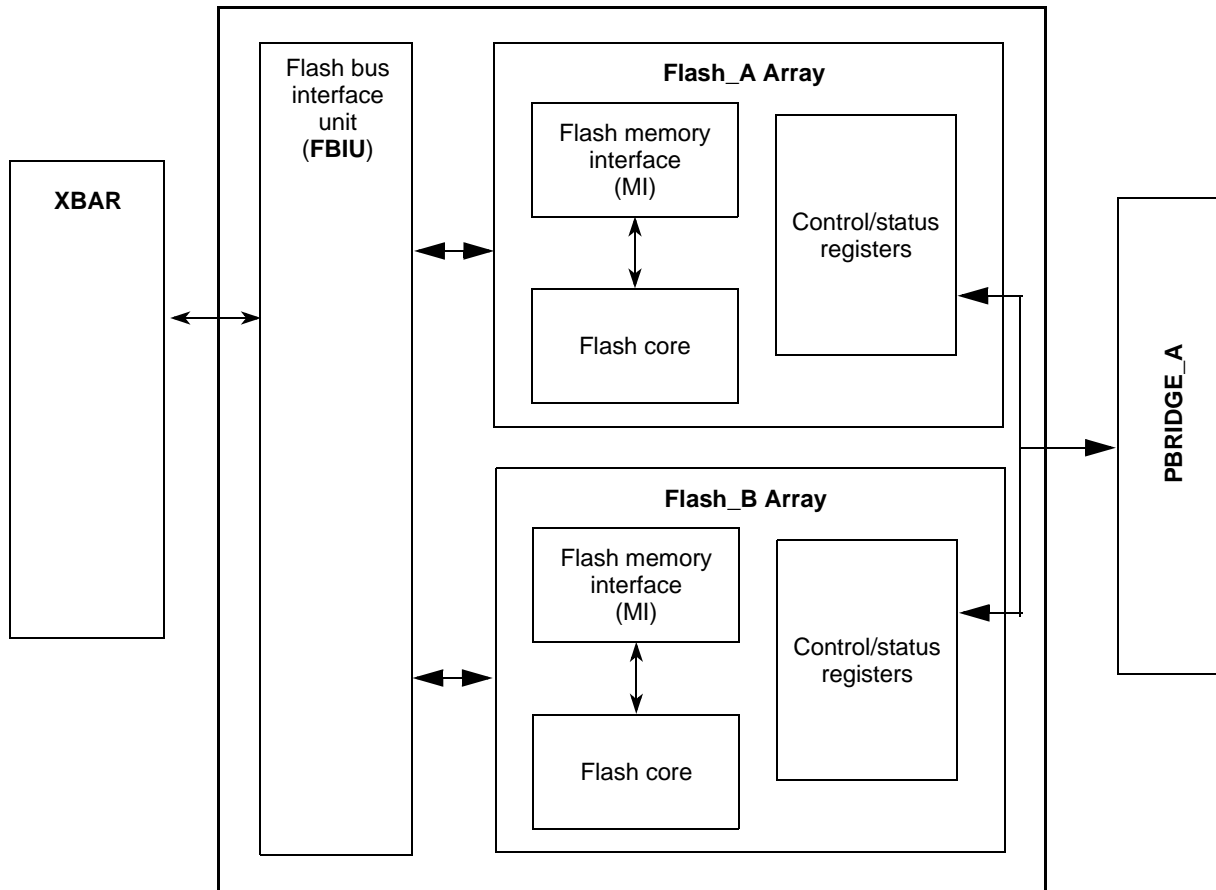

Figure 12-2. Flash Memory Module Block Diagram

12.1.2 Features

The flash memory module has these major features:

- Support for a 64-bit data bus for instruction fetch.
- Support for a 32-bit data bus for CPU loads and DMA access. Byte, halfword, word and doubleword reads are supported. Only aligned word and doubleword writes are supported.
- Configurable read buffering and line prefetch support. Two sets of buffers (one for 128-bit accesses and one for 256-bit accesses) and a prefetch controller are used to support single-cycle read responses for hits in the buffers.
- Hardware and software configurable read and write access protections on a per-master basis.
- Interface to the flash array controller is pipelined with a depth of 1, allowing overlapped accesses to proceed in parallel.
- Configurable access timing allowing use in a wide range of system frequencies.
- Multiple-mapping support and mapping-based block access timing (0-31 additional cycles) allowing use for emulation of other memory types.

- Software programmable block program/erase restriction control for low, mid and high address spaces.
- Erase of selected block(s).
- Read page size of 128 bits (low/mid-address space) and 256 bits (for high-address space).
- ECC with single-bit correction, single-bit detection, and double-bit detection.
- Minimum program size is 2 consecutive 32 bit words, aligned on a 0-modulo-8 byte address, due to ECC.
- Embedded hardware program and erase algorithm.
- Read while Write with multiple partitions.
- Erase suspend, program suspend and erase-suspended program.
- Automotive flash which meets automotive endurance and reliability requirements.
- Shadow information stored in non-volatile shadow block.
- Independent program/erase of the shadow block.

12.1.3 Modes of Operation

12.1.3.1 Flash User Mode

User mode is the default operating mode of the flash module. In this mode, it is possible to read and write, program and erase the flash module.

12.1.3.2 User Test Mode

User Test (UTest) mode is where a portion of the Freescale test modes are made available to end users. This mode is protected, but accessible.

12.2 Memory Map and Registers

This section provides a detailed description of all flash memory registers.

12.2.1 Module Memory Map

The flash memory map is shown below. The addresses are given as an offset to the flash memory base address.

There are no program-visible registers that physically reside in the flash. The flash controller contains the registers to control and configure the flash (see [Table 12-3](#)). Only reference these registers with 32-bit accesses.

Table 12-1. Memory Map

| Offset from FLASH_BASE (0x0000_0000) | Use | Flash A Block | Flash B Block | Partition | Flash A Block Size | Flash B Block Size | Data Width |
|--------------------------------------|---|-----------------------------|---------------|------------------|--------------------|--------------------|------------|
| 0x0000_0000 | Low-address space (Flash A) | L0 | — | 1 | 16K | — | 128 |
| 0x0000_4000 | | L1 | — | | 16K | — | 128 |
| 0x0000_8000 | | L2 | — | | 16K | — | 128 |
| 0x0000_C000 | | L3 | — | | 16K | — | 128 |
| 0x0001_0000 | | L4 | — | 2 | 16K | — | 128 |
| 0x0001_4000 | | L5 | — | | 16K | — | 128 |
| 0x0001_8000 | | L6 | — | | 16K | — | 128 |
| 0x0001_C000 | | L7 | — | | 16K | — | 128 |
| 0x0002_0000 | | Mid-address space (Flash A) | L8 | — | 3 | 64K | — |
| 0x0003_0000 | L9 | | — | 64K | | — | 128 |
| 0x0004_0000 | Mid-address space (Flash A) | M0 | — | 4 | 128K | — | 128 |
| 0x0006_0000 | | M1 | — | | 128K | — | 128 |
| 0x0008_0000 | Low-address space (Flash B) | — | L0 | 5 | — | 256K | 128 |
| 0x000C_0000 | Mid-address space (Flash B) | — | M0 | | — | 256K | 128 |
| 0x0010_0000 | High-address space ¹ | H0 | H0 | 6 | 256K | 256K | 256 |
| 0x0018_0000 | | H1 | H1 | | 256K | 256K | 256 |
| 0x0020_0000 | | H2 | H2 | 7 | 256K | 256K | 256 |
| 0x0028_0000 | H3 | H3 | 256K | | 256K | 256 | |
| 0x0030_0000 | | H4 | H4 | 8 | 256K | 256K | 256 |
| 0x0038_0000 | | H5 | H5 | | 256K | 256K | 256 |
| 0x0040_0000 | Reserved | | | | | | |
| 0x00EF_C000 | Shadow Block (Flash B space) (see Table 12-2) | — | S0 | All ² | — | 16K | 128 |
| 0x00FF_C000 | Shadow Block (Flash A space) (see Table 12-2) | S0 | — | | 16K | — | 128 |
| 0x0100_C000 | Reserved | | | | | | |

¹ See Figure 12-1 to see how Flash A and Flash B, together, make up the high address space.

² For read while write operations, the shadow row behaves as if it is in all partitions.

Table 12-2 shows the shadow block space. The 16K region of the Shadow Block for Flash B space mirrors from 0x00E0_0000 to 0x00EF_FFFF and Shadow A mirrors every 16K from 0x00F0_0000 through 0x00FF_FFFF. Mirrored operation is not guaranteed

Flash_A and Flash_B arrays have separate configuration and control registers for programming and erase operations. Flash bus configuration registers are common to both arrays.

Table 12-2. Shadow Block Memory Map

| Offset from FLASH_BASE (0x0000_0000) | Shadow Block | Use |
|--------------------------------------|--------------|---|
| 0x00EF_C000 | Flash B | General use |
| 0x00EF_DDE8 | | FLASH_B_LMLR reset configuration |
| 0x00EF_DDF0 | | FLASH_B_HLR reset configuration |
| 0x00EF_DDE8 | | FLASH_B_SLMLR reset configuration |
| 0x00FF_C000–0x00FF_FDD7 | Flash A | General use |
| 0x00FF_FDD8 | | Serial passcode (0xFEED_FACE_CAFE_BEEF) |
| 0x00FF_FDE0 | | Censorship control word (0x55AA_55AA) |
| 0x00FF_FDE4 | | General use |
| 0x00FF_FDE8 | | FLASH_A_LMLR reset configuration (0x0010_0000) |
| 0x00FF_FDEC | | General use |
| 0x00FF_FDF0 | | FLASH_A_HLR reset configuration (0xFFFF_FFFF) |
| 0x00FF_FDF4 | | General use |
| 0x00FF_FDF8 | | FLASH_A_SLMLR reset configuration (0x000F_FFFF) |
| 0x00FF_FE00 | | FLASH_BIUCR2 reset configuration (0xFFFF_FFFF) |
| 0x00FF_FDFC–0x00FF_FFFF | | General use |

Table 12-3. Flash Configuration Register Memory Map

| Offset from FLASH_REGS_BASE (0xC3F8_8000) | Register | Bits | Access | Reset Value ¹ | Section/Page |
|---|---|------|--------|--------------------------|--------------------------------|
| 0x0000 | FLASH_A_MCR—Module configuration register | 32 | R/W | 0x0000_0400 | 12.2.2.1/12-8 |
| 0x0004 | FLASH_A_LMLR—Low-/Mid-address space block locking register | 32 | R/W | — | 12.2.2.2/12-12 |
| 0x0008 | FLASH_A_HLR—High-address space block locking register | 32 | R/W | — | 12.2.2.3/12-14 |
| 0x000C | FLASH_A_SLMLR—Secondary low-/mid-address space block locking register | 32 | R/W | — | 12.2.2.4/12-16 |
| 0x0010 | FLASH_A_LMSR—Low-/mid-address space block select register | 32 | R/W | 0x0000_0000 | 12.2.2.5/12-17 |
| 0x0014 | FLASH_A_HSR—High-address space block select register | 32 | R/W | 0x0000_0000 | 12.2.2.6/12-18 |
| 0x0018 | FLASH_A_AR—Address register | 32 | R/W | 0x0000_0000 | 12.2.2.7/12-18 |
| 0x001C | FLASH_BIUCR—Flash Bus Interface configuration register | 32 | R/W | 0x0000_FF00 | 12.2.2.8/12-19 |
| 0x0020 | FLASH_BIUAPR—Flash Bus Interface access protection register | 32 | R/W | 0xFFFF_FFFF | 12.2.2.9/12-22 |

Table 12-3. Flash Configuration Register Memory Map

| Offset from FLASH_REGS_BASE (0xC3F8_8000) | Register | Bits | Access | Reset Value ¹ | Section/Page |
|---|---|------|--------|--------------------------|---------------------------------|
| 0x0024 | FLASH_BIUCR2—Flash Bus Interface configuration register 2 | 32 | R/W | — | 12.2.2.10/12-23 |
| 0x0028 – 0x0038 | Reserved | | | | |
| 0x003C | FLASH_A_UT0—UTest 0 Register | 32 | R/W | 0x0000_0001 | 12.2.2.11/12-24 |
| 0x0040 | FLASH_A_UT1—UTest 1 Register | 32 | R/W | 0x0000_0001 | 12.2.2.12/12-27 |
| 0x0044 | FLASH_A_UT2—UTest 2 Register | 32 | R/W | 0x0000_0001 | 12.2.2.13/12-27 |
| 0x0048 – 0x3FFF | Reserved | | | | |
| 0x4000 | FLASH_B_MCR—Module configuration register | 32 | R/W | 0x0000_0400 | 12.2.2.1/12-8 |
| 0x4004 | FLASH_B_LMLR—Low-/Mid-address space block locking register | 32 | R/W | — | 12.2.2.2/12-12 |
| 0x4008 | FLASH_B_HLR—High-address space block locking register | 32 | R/W | — | 12.2.2.3/12-14 |
| 0x400C | FLASH_B_SLMLR—Secondary low-/mid-address space block locking register | 32 | R/W | — | 12.2.2.4/12-16 |
| 0x4010 | FLASH_B_LMSR—Low-/mid-address space block select register | 32 | R/W | 0x0000_0000 | 12.2.2.5/12-17 |
| 0x4014 | FLASH_B_HSR—High-address space block select register | 32 | R/W | 0x0000_0000 | 12.2.2.6/12-18 |
| 0x4018 | FLASH_B_AR—Address register | 32 | R/W | 0x0000_0000 | 12.2.2.7/12-18 |
| 0x401c – 0x4038 | Reserved | | | | |
| 0x403C | FLASH_B_UT0—UTest 0 Register | 32 | R/W | 0x0000_0001 | 12.2.2.11/12-24 |
| 0x4040 | FLASH_B_UT1—UTest 1 Register | 32 | R/W | 0x0000_0001 | 12.2.2.12/12-27 |
| 0x4044 | FLASH_B_UT2—UTest 2 Register | 32 | R/W | 0x0000_0001 | 12.2.2.13/12-27 |
| 0x4048 – 0x7FFF | Reserved | | | | |

¹ A value of “—” means that the register is loaded from the shadow block described in [Figure 12-2](#).

12.2.2 Register Descriptions

This section lists the flash memory registers in address order and describes the registers and their bit fields.

NOTE

Each of the two flash arrays (Flash_A and Flash_B) have separate configuration registers and control registers for programming and erase operations. In the following register descriptions, the letter “x” represents “A” for Flash_A registers, and “B” for Flash_B registers. Registers without the “x” designator are common to both arrays and are used to control the flash bus interface.

12.2.2.1 Module Configuration Register (FLASH_x_MCR)

The FLASH_x_MCR register is defined [Figure 12-3](#) and [Table 12-4](#).

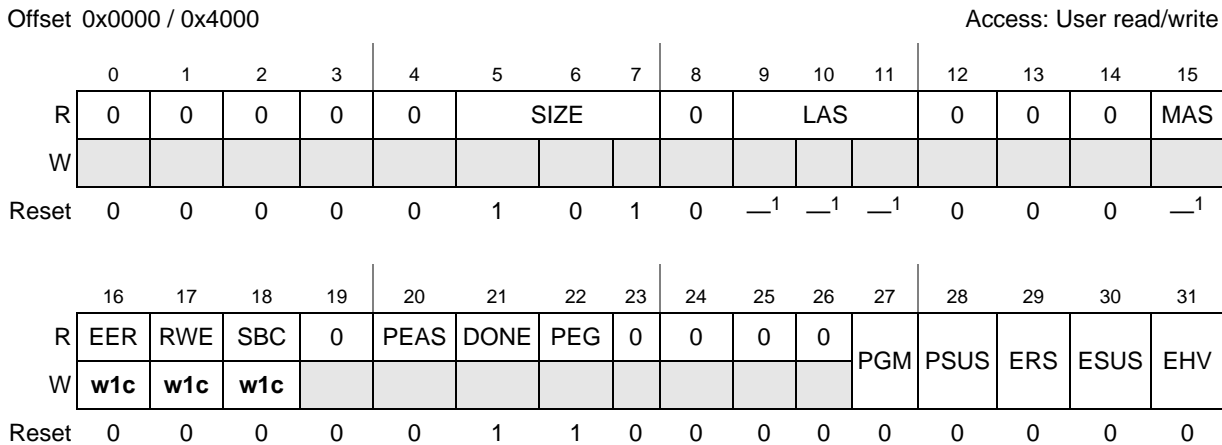

¹ See register description below.

Figure 12-3. Module Configuration Register (FLASH_x_MCR)

Table 12-4. FLASH_x_MCR Field Descriptions

| Field | Description |
|------------------|---|
| 0–4 | Reserved |
| 5–7 SIZE | Array Space Size. The value of the SIZE field is dependent upon the size of the flash array. SIZE is read only. 101 2.0 MB. (256 KB of LAS, 256 KB of MAS, and 1.5 MB of HAS) (Both Flash_A and Flash_B) All others are Reserved. |
| 8 | Reserved |
| 9–11 LAS[2:0] | Low Address Space. The value of the LAS field corresponds to the configuration of the Low Address Space. LAS is read only. 000 One 256 KB Blocks. (Flash_B) 100 Eight 16 KB, two 64 KB Blocks. (Flash_A) All others are Reserved. |
| 12–14 | Reserved |
| 15 MAS | Mid Address Space. The value of the MAS field corresponds to the configuration of the Mid Address Space. MAS is read only. 0 Two 128 KB Blocks. (Flash_A) 1 One 256 KB Blocks. (Flash_B) |
| 16 EER | ECC Event Error. EER provides information on previous reads. If a double bit detection occurred, the EER bit is set to a 1. This bit must then be cleared, or a reset must occur before this bit returns to a 0 state. This bit may not be set by the user. In the event of a single bit detection and correction, this bit is not be set. If EER is not set, or remains 0, this indicates that all previous reads (from the last reset, or clearing of EER) are correct. Since this bit is an error flag, it must be cleared to a 0 by writing a 1 to the register location. A write of 0 has no effect. 0 Reads are occurring normally. 1 An ECC Error occurred during a previous read. |

Table 12-4. FLASH_x_MCR Field Descriptions (continued)

| Field | Description |
|------------|---|
| 17 RWE | <p>Read While Write Event Error. RWE provides information on previous RWW reads. If a Read While Write error occurs, this bit is set to 1. This bit must then be cleared, or a reset must occur before this bit returns to a 0 state. This bit may not be written to a 1 by the user. If RWE is not set, or remains 0, this indicates that all previous RWW reads (from the last reset, or clearing of RWE) are correct. Since this bit is an error flag, it must be cleared to a 0 by writing a 1 to the register location. A write of 0 has no effect.</p> <p>0 Reads are occurring normally. 1 A Read While Write Error occurred during a previous read.</p> |
| 18 SBC | <p>Single Bit Correction. SBC provides information on previous reads provided the FLASH_x_UT0[SPCE] is set. If a single bit correction occurred, the SBC bit is set to a 1. This bit must then be cleared, or a reset must occur before this bit returns to a 0 state. If SBC is not set, or remains 0, this indicates that all previous reads (from the last reset, or clearing of SBC) did not require a correction. Since this bit is an error flag, it must be cleared to a 0 by writing a 1 to the register location. A write of 0 has no effect.</p> <p>0 Reads are occurring without corrections. 1 A Single Bit Correction occurred during a previous read.</p> |
| 19 | Reserved |
| 20 PEAS | <p>Program/Erase Access Space. PEAS is used to indicate which space is valid for program and erase operations, either main array space or shadow space. PEAS = 0 indicates that the main address space is active for all FC program and erase operations. PEAS = 1 indicates the shadow address space is active for program/erase. The value in PEAS is captured and held when the shadow block is enabled with the first interlock write done for program or erase operations. The value of PEAS is retained between sampling events (i.e. subsequent first interlock writes). The value in PEAS may be changed during erase-suspended program, and reverts back to its' original state once the erase-suspended program is completed. PEAS is read only.</p> <p>0 Shadow address space is disabled for program/erase and main address space enabled. 1 Shadow address space is enabled for program/erase and main address space disabled.</p> |
| 21 DONE | <p>State Machine Status. DONE indicates if the flash module is performing a high voltage operation. DONE is set to a 1 on termination of the flash module reset. DONE is read only. DONE is cleared within Tdone of a 0 to 1 transition of EHV which initiates a high voltage operation. DONE is cleared within Tres of resuming a suspended operation. DONE is set to a 1 at the end of program and erase high voltage sequences. DONE is set to a 1 within Tdone of a 1 to 0 transition of EHV which aborts a high voltage operation.</p> <p>0 Flash is executing a high voltage operation. 1 Flash is not executing a high voltage operation.</p> |
| 22 PEG | <p>Program/Erase Good. The PEG bit indicates the completion status of the last flash program or erase sequence for which high voltage operations were initiated. The value of PEG is updated automatically during the program and erase high voltage operations. Aborting a program/erase high voltage operation causes PEG to be cleared, indicating the sequence failed. PEG is set to a 1 when the module is reset. PEG is read only.</p> <p>The value of PEG is valid only when PGM = 1 and/or ERS = 1 and after DONE transitions from 0 to 1 due to an abort or the completion of a program/erase operation. PEG is valid until PGM/ERS makes a 1 to 0 transition or EHV makes a 0 to 1 transition. The value in PEG is not valid after a 0 to 1 transition of DONE caused by PSUS or ESUS being set to logic 1. If PGM and ERS are both 1 when DONE makes a qualifying 0 to 1 transition the value of PEG indicates the completion status of the PGM sequence. This happens in an erase-suspended program operation.</p> <p>0 Program or erase operation failed. 1 Program or erase operation successful.</p> <p>Note: If program or erases are attempted on blocks that are locked, the response from flash is PEG = 1, indicating that the operation was successful, and the contents of the block are properly protected from the program or erase operation.</p> |

Table 12-4. FLASH_x_MCR Field Descriptions (continued)

| Field | Description |
|------------|---|
| 23–26 | Reserved |
| 27 PGM | <p>Program. PGM is used to set up flash for a program operation. A 0 to 1 transition of PGM initiates a program sequence. A 1 to 0 transition of PGM ends the program sequence. PGM can be set only under one of the following conditions:</p> <ul style="list-style-type: none"> • User mode read (ERS is low and UTE is low). • Erase suspend (ERS and ESUS are 1) with EHV low. <p>PGM can be cleared by the user only when PSUS and EHV are low and DONE is high. PGM is cleared on reset.</p> <p>0 Flash is not executing a program sequence. 1 Flash is executing a program sequence.</p> <p>Note: In an erase-suspended program, programming Flash locations in blocks which were being operated on in the erase may corrupt FC data. This should be avoided due to reliability implications.</p> |
| 28 PSUS | <p>Program Suspend. PSUS is used to indicate the flash module is in program suspend or in the process of entering a suspend state. The module is in program suspend when PSUS = 1 and DONE = 1. PSUS can be set high only when PGM and EHV are high. A 0 to 1 transition of PSUS starts the sequence which sets DONE and places the flash module in program suspend. The module enters suspend within Tpsus of this transition.</p> <p>PSUS can be cleared only when DONE and EHV are high. A 1 to 0 transition of PSUS with EHV = 1 starts the sequence which clears DONE and returns the flash module to program. The module cannot exit program suspend and clear DONE while EHV is low. PSUS is cleared on reset.</p> <p>0 Program sequence is not suspended. 1 Program sequence is suspended.</p> |
| 29 ERS | <p>Erase. ERS is used to set up flash for an erase operation. A 0 to 1 transition of ERS initiates an erase sequence. A 1 to 0 transition of ERS ends the erase sequence. ERS can only be set only in user mode read (PGM is low and UTE is low). ERS can be cleared by the user only when ESUS and EHV are low and DONE is high. ERS is cleared on reset.</p> <p>0 Flash is not executing an erase sequence. 1 Flash is executing an erase sequence.</p> |

Table 12-4. FLASH_x_MCR Field Descriptions (continued)

| Field | Description |
|------------|---|
| 30 ESUS | <p>Erase Suspend. ESUS is used to indicate that the flash module is in erase suspend or in the process of entering a suspend state. The module is in erase suspend when ESUS = 1 and DONE = 1. ESUS can be set high only when ERS and EHV are high and PGM is low. A 0 to 1 transition of ESUS starts the sequence which sets DONE and places the flash in erase suspend. The flash module enters suspend within Tesus of this transition.</p> <p>ESUS can be cleared only when DONE and EHV are high and PGM is low. A 1 to 0 transition of ESUS with EHV = 1 starts the sequence which clears DONE and returns the module to erase. The flash module cannot exit erase suspend and clear DONE while EHV is low. ESUS is cleared on reset.</p> <p>0 Erase sequence is not suspended. 1 Erase sequence is suspended.</p> |
| 31 EHV | <p>Enable High Voltage. The EHV bit enables the flash module for a high voltage program/erase operation. EHV is cleared on reset. EHV must be set after an interlock write to start a program/erase sequence. EHV may be set, initiating a program/erase, after an interlock under one of the following conditions:</p> <ul style="list-style-type: none"> • Erase (ERS = 1, ESUS = 0). • Program (ERS = 0, ESUS = 0, PGM = 1, PSUS = 0). • Erase-suspended program (ERS = 1, ESUS = 1, PGM = 1, PSUS = 0). <p>If a program operation is to be initiated while an erase is suspended the user must clear EHV while in erase suspend before setting PGM.</p> <p>In normal operation, a 1 to 0 transition of EHV with DONE high, PSUS and ESUS low terminates the current program/erase high voltage operation.</p> <p>When an operation is aborted, there is a 1 to 0 transition of EHV with DONE low and the suspend bit for the current program/erase sequence low. An abort causes the value of PEG to be cleared, indicating a failed program/erase; address locations being operated on by the aborted operation contain indeterminate data after an abort.</p> <p>A suspended operation cannot be aborted. EHV may be written during suspend. EHV must be high for the flash module to exit suspend. EHV may not be written after a suspend bit is set high and before DONE transitions high. EHV may not be set low after the current suspend bit is set low and before DONE transitions low.</p> <p>0 Flash is not enabled to perform a high voltage operation. 1 Flash is enabled to perform a high voltage operation.</p> <p>Note: Aborting a high voltage operation leaves FC addresses in an indeterminate data state. This may be recovered by executing an erase on the affected blocks.</p> |

12.2.2.1.1 FLASH_x_MCR Simultaneous Bit Write Priority

A number of FLASH_x_MCR bits are protected against write when another bit, or set of bits, is in a specific state. These write locks are covered on a bit by bit basis in the preceding section. The write locks detailed in the previous section do not consider the effects of trying to write two or more bits simultaneously. The effects of writing bits simultaneously which put the module in an illegal state are detailed here.

The flash module does not allow the user to write bits simultaneously which put the device into an illegal state. This is implemented through a priority mechanism among the bits. The bit changing priorities are detailed in [Table 12-5](#).

Table 12-5. FLASH_x_MCR Bit Set/Clear Priority Levels

| Priority Level | FLASH_x_MCR Bit(s) |
|----------------|--------------------|
| 1 | ERS |
| 2 | PGM |
| 3 | EHV |
| 4 | ESUS, PSUS |

If the user attempts to write two or more FLASH_x_MCR bits simultaneously then only the bit with the lowest priority level is written. Setting two bits with the same priority level is prevented by existing write locks or do not put the flash in an illegal state.

For example, setting ERS and PGM simultaneously results in only ERS being set. Attempting to clear EHV while setting PSUS results in EHV being cleared, while PSUS is unaffected.

12.2.2.2 Low/Mid Address Space Block Locking Register (FLASH_x_LMLR)

The Low/Mid Address Block Locking Register (FLASH_x_LMLR) provides a means to protect blocks from being modified. These bits, along with bits in the Secondary LLOCK (FLASH_x_SLMLR), determine if the block is locked from program or erase. An “OR” of FLASH_x_LMLR and FLASH_x_SLMLR determine the final lock status.

NOTE

A reset value of 1* in [Figure 12-4](#) indicates that the reset value of these registers is determined by Flash values in the shadow block. An erased shadow block causes the reset value to be 1.

The following field and bit descriptions fully define the FLASH_x_LMLR register ([Figure 12-4](#)).

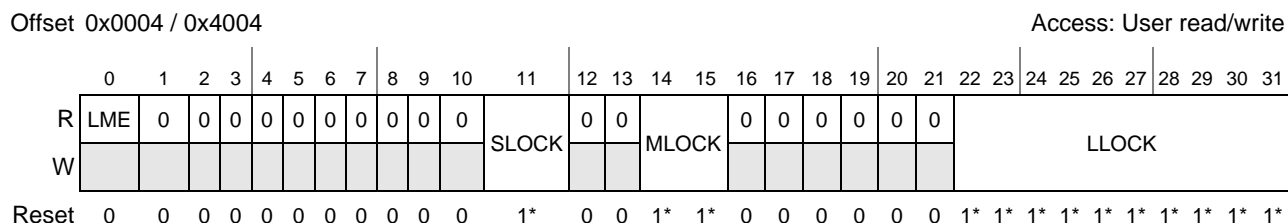

Figure 12-4. FLASH_x_LMLR Register

FLASH_x_LMLR register functions, as shown in [Table 12-6](#).

Table 12-6. FLASH_x_LMLR Field Descriptions

| Field | Description | | | | | | | | | |
|---------------------|--|---------------|---------------|---------------|---|----|----|---|----|------|
| 0 LME | <p>Low/Mid Address Lock Enable. This bit is used to enable the Lock registers (SLOCK, MLOCK and LLOCK) to be set or cleared by register writes. This bit is a status bit only, and may not be written or cleared, and the reset value is 0. The method to set this bit is to write a password, and if the password matches, the LME bit is set to reflect the status of enabled, and is enabled until a reset operation occurs. For LME, the password 0xA1A1_1111 must be written to the FLASH_x_LMLR register.</p> <p>0 Low/Mid Address Locks are disabled, and can not be modified. 1 Low/Mid Address Locks are enabled to be written.</p> | | | | | | | | | |
| 1–10 | Reserved | | | | | | | | | |
| 11 SLOCK | <p>Shadow Lock. This bit is used to lock the shadow block from programs and erases. A value of 1 in the SLOCK register signifies that the shadow block is locked for program and erase. A value of 0 in the SLOCK register signifies that the shadow block is available to receive program and erase pulses. The SLOCK register is not writable once an interlock write is completed until FLASH_x_MCR[<i>DONE</i>] is set at the completion of the requested operation. Likewise, SLOCK register is not writable if a high voltage operation is suspended. SLOCK is also not writeable during UTest operations, when AIE is high. Upon reset, information from the shadow block is loaded into the SLOCK register. The SLOCK bit may be written as a register. Reset causes the bits to go back to their shadow block value. The default value of the SLOCK bits (assuming erased shadow location) is locked. SLOCK is not writable unless LME is high.</p> | | | | | | | | | |
| 12–13 | Reserved | | | | | | | | | |
| 14–15 MLOCK[1:0] | <p>Mid Address Space Block Lock. A value of 1 in a bit of the lock register signifies that the corresponding block is locked for program and erase. A value of 0 in the lock register signifies that the corresponding block is available to receive program and erase pulses. The block numbering for Mid Address Space is given in the table below, and is different for Flash_A and Flash_B.</p> <table border="1" style="margin-left: auto; margin-right: auto;"> <thead> <tr> <th>MLOCK Bit</th> <th>Flash_A Block</th> <th>Flash_B Block</th> </tr> </thead> <tbody> <tr> <td>0</td> <td>M0</td> <td>M0</td> </tr> <tr> <td>1</td> <td>M1</td> <td>none</td> </tr> </tbody> </table> <p>The lock register is not writable once an interlock write is completed until FLASH_x_MCR[<i>DONE</i>] is set at the completion of the requested operation. Likewise, the lock register is not writable if a high voltage operation is suspended. MLOCK is also not writeable during UTest operations, when AIE is high. Upon reset, information from the shadow block is loaded into the block registers. The LOCK bits may be written as a register. Reset causes the bits to go back to their shadow block value. The default value of the LOCK bits (assuming erased shadow location) is locked.</p> <p>In the event that blocks are not present (due to configuration or total memory size), the LOCK bits default to be locked, and are not writable. The reset value is always 1 (independent of the shadow block), and register writes have no effect.</p> <p>MLOCK is not writable unless LME is high.</p> | MLOCK Bit | Flash_A Block | Flash_B Block | 0 | M0 | M0 | 1 | M1 | none |
| MLOCK Bit | Flash_A Block | Flash_B Block | | | | | | | | |
| 0 | M0 | M0 | | | | | | | | |
| 1 | M1 | none | | | | | | | | |

Table 12-6. FLASH_x_LMLR Field Descriptions (continued)

| Field | Description | | | | | | | | | | | | | | | | | | | | | | | | | | | | | | | | | |
|----------------|---|---------------|---------------|---------------|---|----|----|---|----|------|---|----|------|---|----|------|---|----|------|---|----|------|---|----|------|---|----|------|---|----|------|---|----|------|
| 16–21 | Reserved | | | | | | | | | | | | | | | | | | | | | | | | | | | | | | | | | |
| 22–31 LLOCK | <p>Low Address Space Block Lock. A value of 1 in a bit of the lock register signifies that the corresponding block is locked for program and erase. A value of 0 in the lock register signifies that the corresponding block is available to receive program and erase pulses. The block numbering for Low Address Space is given in the table below, and is different for Flash_A and Flash_B.</p> <table border="1" style="margin-left: auto; margin-right: auto;"> <thead> <tr> <th>LLOCK Bit</th> <th>Flash_A Block</th> <th>Flash_B Block</th> </tr> </thead> <tbody> <tr><td>0</td><td>L0</td><td>L0</td></tr> <tr><td>1</td><td>L1</td><td>none</td></tr> <tr><td>2</td><td>L2</td><td>none</td></tr> <tr><td>3</td><td>L3</td><td>none</td></tr> <tr><td>4</td><td>L4</td><td>none</td></tr> <tr><td>5</td><td>L5</td><td>none</td></tr> <tr><td>6</td><td>L6</td><td>none</td></tr> <tr><td>7</td><td>L7</td><td>none</td></tr> <tr><td>8</td><td>L8</td><td>none</td></tr> <tr><td>9</td><td>L9</td><td>none</td></tr> </tbody> </table> <p>For more details on LLOCK, please see MLOCK bit description.</p> <p>LLOCK is not writable unless LME is high.</p> | LLOCK Bit | Flash_A Block | Flash_B Block | 0 | L0 | L0 | 1 | L1 | none | 2 | L2 | none | 3 | L3 | none | 4 | L4 | none | 5 | L5 | none | 6 | L6 | none | 7 | L7 | none | 8 | L8 | none | 9 | L9 | none |
| LLOCK Bit | Flash_A Block | Flash_B Block | | | | | | | | | | | | | | | | | | | | | | | | | | | | | | | | |
| 0 | L0 | L0 | | | | | | | | | | | | | | | | | | | | | | | | | | | | | | | | |
| 1 | L1 | none | | | | | | | | | | | | | | | | | | | | | | | | | | | | | | | | |
| 2 | L2 | none | | | | | | | | | | | | | | | | | | | | | | | | | | | | | | | | |
| 3 | L3 | none | | | | | | | | | | | | | | | | | | | | | | | | | | | | | | | | |
| 4 | L4 | none | | | | | | | | | | | | | | | | | | | | | | | | | | | | | | | | |
| 5 | L5 | none | | | | | | | | | | | | | | | | | | | | | | | | | | | | | | | | |
| 6 | L6 | none | | | | | | | | | | | | | | | | | | | | | | | | | | | | | | | | |
| 7 | L7 | none | | | | | | | | | | | | | | | | | | | | | | | | | | | | | | | | |
| 8 | L8 | none | | | | | | | | | | | | | | | | | | | | | | | | | | | | | | | | |
| 9 | L9 | none | | | | | | | | | | | | | | | | | | | | | | | | | | | | | | | | |

12.2.2.3 High Address Space Block Locking Register (FLASH_x_HLR)

The High Address Space Block Locking Register (FLASH_x_HLR) provides a means to protect blocks from being modified.

NOTE

A reset value of 1* in [Figure 12-5](#) indicates that the reset value of these registers is determined by Flash values in the shadow block. An erased shadow block causes the reset value to be 1.

The following field and bit descriptions fully define the FLASH_x_HLR register ([Figure 12-5](#)).

Offset 0x0008 / 0x4008

Access: User read/write

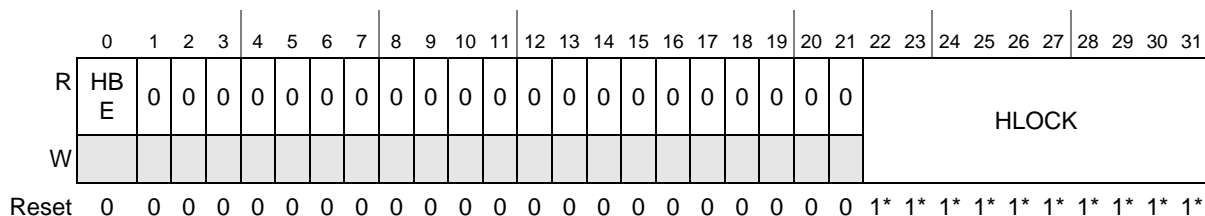

Figure 12-5. FLASH_x_HLR Register

FLASH_x_HLR register functions, as shown in Table 12-7.

Table 12-7. FLASH_x_HLR Field Descriptions

| Field | Description | | | | | | | | | | | | | | | | | | | | | | | | | | | | | | | | | |
|----------------|--|---------------|---------------|---------------|---|----|----|---|----|----|---|----|----|---|----|----|---|----|----|---|----|----|---|----|----|---|----|----|---|----|----|---|----|----|
| 0 HBE | High Address Lock Enable This bit is used to enable the Lock registers (HLOCK) to be set or cleared by register writes. This bit is a status bit only, and may not be written or cleared, and the reset value is 0. The method to set this bit is to provide a password, and if the password matches, the HBE bit is set to reflect the status of enabled, and is enabled until a reset operation occurs. For HBE, the password 0xB2B2_2222 must be written to the FLASH_x_HLR register. 0 High Address Locks are disabled, and can not be modified. 1 High Address Locks are enabled to be written. | | | | | | | | | | | | | | | | | | | | | | | | | | | | | | | | | |
| 1–21 | Reserved | | | | | | | | | | | | | | | | | | | | | | | | | | | | | | | | | |
| 22–31 HLOCK | High Address Space Block Lock. HLOCK has the same characteristics as LLOCK. Please see this description for more information. The block numbering for High Address Space is given in the table below, and is the same for Flash_A and Flash_B. <table border="1" style="margin: 10px auto;"> <thead> <tr> <th>HLOCK Bit</th> <th>Flash_A Block</th> <th>Flash_B Block</th> </tr> </thead> <tbody> <tr><td>0</td><td>H0</td><td>H0</td></tr> <tr><td>1</td><td>H1</td><td>H1</td></tr> <tr><td>2</td><td>H2</td><td>H2</td></tr> <tr><td>3</td><td>H3</td><td>H3</td></tr> <tr><td>4</td><td>H4</td><td>H4</td></tr> <tr><td>5</td><td>H5</td><td>H5</td></tr> <tr><td>6</td><td>H6</td><td>H6</td></tr> <tr><td>7</td><td>H7</td><td>H7</td></tr> <tr><td>8</td><td>H8</td><td>H8</td></tr> <tr><td>9</td><td>H9</td><td>H9</td></tr> </tbody> </table> <p>HLOCK is not writable unless HBE is high.</p> | HLOCK Bit | Flash_A Block | Flash_B Block | 0 | H0 | H0 | 1 | H1 | H1 | 2 | H2 | H2 | 3 | H3 | H3 | 4 | H4 | H4 | 5 | H5 | H5 | 6 | H6 | H6 | 7 | H7 | H7 | 8 | H8 | H8 | 9 | H9 | H9 |
| HLOCK Bit | Flash_A Block | Flash_B Block | | | | | | | | | | | | | | | | | | | | | | | | | | | | | | | | |
| 0 | H0 | H0 | | | | | | | | | | | | | | | | | | | | | | | | | | | | | | | | |
| 1 | H1 | H1 | | | | | | | | | | | | | | | | | | | | | | | | | | | | | | | | |
| 2 | H2 | H2 | | | | | | | | | | | | | | | | | | | | | | | | | | | | | | | | |
| 3 | H3 | H3 | | | | | | | | | | | | | | | | | | | | | | | | | | | | | | | | |
| 4 | H4 | H4 | | | | | | | | | | | | | | | | | | | | | | | | | | | | | | | | |
| 5 | H5 | H5 | | | | | | | | | | | | | | | | | | | | | | | | | | | | | | | | |
| 6 | H6 | H6 | | | | | | | | | | | | | | | | | | | | | | | | | | | | | | | | |
| 7 | H7 | H7 | | | | | | | | | | | | | | | | | | | | | | | | | | | | | | | | |
| 8 | H8 | H8 | | | | | | | | | | | | | | | | | | | | | | | | | | | | | | | | |
| 9 | H9 | H9 | | | | | | | | | | | | | | | | | | | | | | | | | | | | | | | | |

12.2.2.4 Secondary Low/Mid Address Space Block Locking Register (FLASH_x_SLMLR)

The Secondary Low/Mid Address Block Locking Register (FLASH_x_SLMLR) provides an alternative means to protect blocks from being modified. This has the effect of creating a “tiered” locking scheme to enable different flash users to provide different default locking on blocks. These bits, along with bits in the LLOCK (FLASH_x_LMLR), determine if the block is locked from program or erase. An “OR” of FLASH_x_LMLR and FLASH_x_SLMLR determine the final lock status.

NOTE

A reset value of 1* in Figure 12-6 indicates that the reset value of these registers is determined by Flash values in the shadow block. An erased shadow block causes the reset value to be 1.

The following field and bit descriptions fully define the FLASH_x_SLMLR register (Figure 12-6).

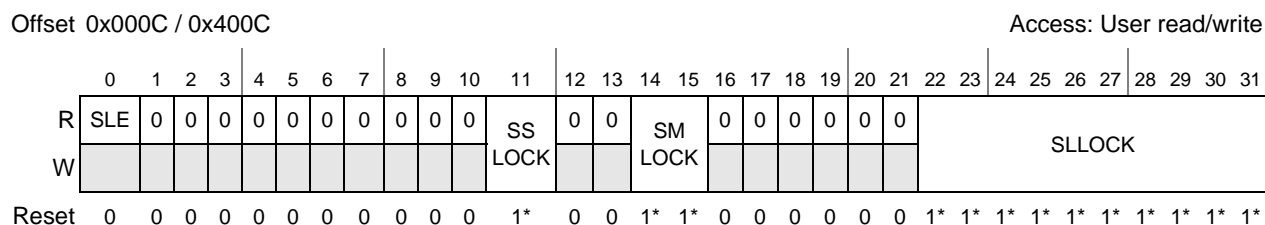

Figure 12-6. FLASH_x_SLMLR Register

NOTE

Writing the password 0xC3C3_3333 to this register does not modify the SSLOCK, SMLOCK, or SLLOCK fields. Only the SLE bit changes.

FLASH_x_SLMLR register functions, as shown in Table 12-8.

Table 12-8. FLASH_x_SLMLR Field Descriptions

| Field | Description |
|--------------|--|
| 0 SLE | Secondary Low/Mid Address Lock Enable. This bit is used to enable the Lock registers (SSLOCK, SMLOCK, and SLLOCK) to be set or cleared by register writes. This bit is a status bit only, and may not be written or cleared, and the reset value is 0. The method to set this bit is to provide a password, and if the password matches, the SLE bit is set to reflect the status of enabled, and is enabled until a reset operation occurs. For SLE, the password 0xC3C3_3333 must be written to the FLASH_x_SLMLR register 0 Secondary Low/Mid Address Locks are disabled, and can not be modified. 1 Secondary Low/Mid Address Locks are enabled to be written. |
| 1–10 | Reserved |
| 11 SSLOCK | Secondary Shadow Lock. This bit is an alternative method that may be used to lock the shadow block from programs and erases. SSLOCK has the same description as SLOCK in the FLASH_x_LMLR register (see Figure 12-4). SSLOCK is not writable unless SLE is high. |
| 12–13 | Reserved |

Table 12-8. FLASH_x_SLMLR Field Descriptions (continued)

| Field | Description |
|-----------------|---|
| 14–15 SMLOCK | Secondary Mid Address Block Lock. This bit is an alternative method that may be used to lock the Mid Address Space blocks from programs and erases. SMLOCK has the same description as MLOCK in the FLASH_x_LMLR register. SMLOCK is not writable unless SLE is high. |
| 16–21 | Reserved |
| 22–31 SLLOCK | Secondary Low Address Block Lock. This bit is an alternative method that may be used to lock the Low Address Space blocks from programs and erases. SLLOCK has the same description as LLOCK in the FLASH_x_LMLR register. SLLOCK is not writable unless SLE is high. |

12.2.2.5 Low/Mid Address Space Block Select Register (FLASH_x_LMSR)

The Low/Mid Address Space Block Select Register (FLASH_x_LMSR) provides a means to select blocks to be operated on during erase.

The following field and bit descriptions fully define the FLASH_x_LMSR register ([Figure 12-7](#)).

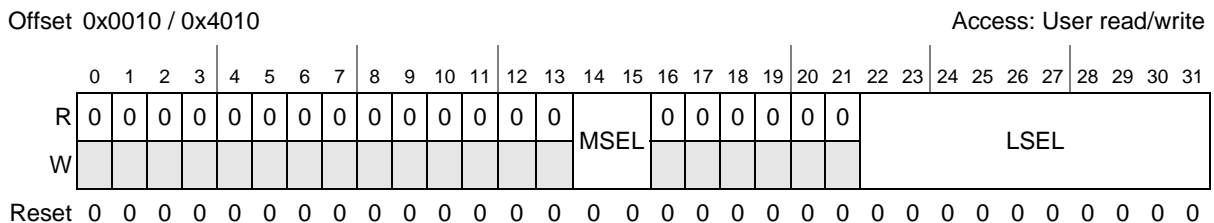
Figure 12-7. FLASH_x_LMSR Register

FLASH_x_LMSR register functions, as shown in [Table 12-9](#).

Table 12-9. FLASH_x_LMSR Field Descriptions

| Field | Description |
|---------------|---|
| 0–13 | Reserved |
| 14–15 MSEL | <p>Mid Address Space Block Select. A value of 1 in the select register signifies that the block is selected for erase. A value of 0 in the select register signifies that the block is not selected. The reset value for the select registers is 0, or un-selected.</p> <p>The blocks must be selected (or un-selected) before doing an erase interlock write as part of the erase sequence. The select register is not writable once an interlock write is completed until FLASH_x_MCR[<i>DONE</i>] is set at the completion of the requested operation, or if a high voltage operation is suspended. MSEL is also not writeable during UTest operations, when AIE is high.</p> <p>In the event that blocks are not present (due to configuration or total memory size), the corresponding select bits default to un-selected, and are not writable. The reset value is always 0, and register writes have no effect.</p> <p>MSEL bits are mapped to block numbers in the same way as described for the MLOCK bits of the FLASH_x_LMLR register.</p> |

Table 12-9. FLASH_x_LMSR Field Descriptions (continued)

| Field | Description |
|--------------------|---|
| 16–21 | Reserved |
| 22–31 LSEL[9:0] | <p>Low Address Space Block Select. A value of 1 in the select register signifies that the block is selected for erase. A value of 0 in the select register signifies that the block is not selected. The reset value for the select registers is 0, or un-selected.</p> <p>The blocks must be selected (or un-selected) before doing an erase interlock write as part of the erase sequence. The select register is not writable once an interlock write is completed until FLASH_x_MCR[<i>DONE</i>] is set at the completion of the requested operation, or if a high voltage operation is suspended. LSEL is also not writeable during UTest operations, when AIE is high.</p> <p>In the event that blocks are not present (due to configuration or total memory size), the corresponding select bits default to un-selected, and are not writable. The reset value is always 0, and register writes have no effect.</p> <p>LSEL bits are mapped to block numbers in the same way as described for the LLOCK bits of the FLASH_x_LMLR register.</p> |

12.2.2.6 High Address Space Block Select Register (FLASH_x_HSR)

The High Address Space Block Select Register (FLASH_x_HSR) provides a means to select blocks to be operated on during erase.

The following field and bit descriptions fully define the FLASH_x_HSR register (Figure 12-8).

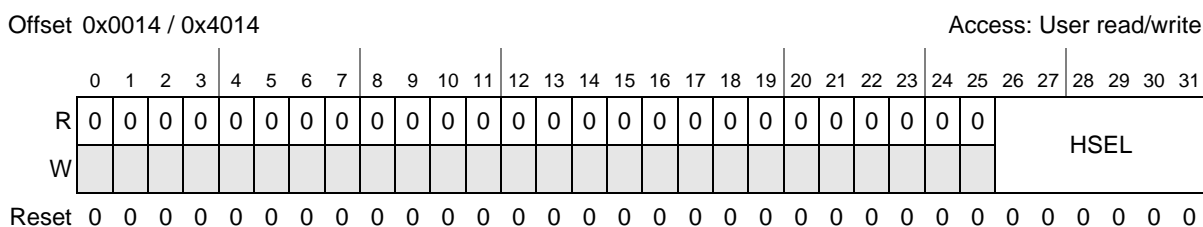

Figure 12-8. FLASH_x_HSR Register

FLASH_x_HSR register functions, as shown in Table 12-10.

Table 12-10. FLASH_x_HSR Field Descriptions

| Field | Description |
|--------------------|--|
| 0–24 | Reserved |
| 26–31 HSEL[5:0] | High Address Space Block Select. High Address Block Select has the same characteristics as LSEL. |

12.2.2.7 Address Register (FLASH_x_AR)

The Address register (FLASH_x_AR) provides the first failing address in the event module failures (ECC or PGM/Erase state machine). This address is the internal array address. To convert to a logical system address, a formula must be applied:

| Array | Address Range | Operation |
|-------|-----------------------|---|
| A | 0x00_0000 - 0x07_FFFF | No change |
| A | 0x08_0000 - 0x1F_FFFF | Logical address[17:3] = Addr[16:4],0,ADDR[3]} |
| B | 0x00_0000 - 0x07_FFFF | Add 0x08_0000 |
| B | 0x08_0000 - 0x1F_FFFF | Logical address[17:3] = Addr[16:4],1,ADDR[3]} |

The following field and bit descriptions fully define the FLASH_x_AR (Figure 12-9).

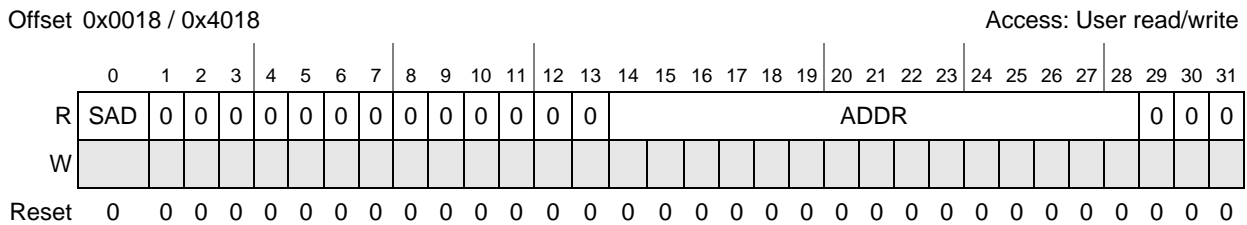

Figure 12-9. FLASH_x_AR Register

FLASH_x_AR functions, as shown in Table 12-11.

Table 12-11. FLASH_x_AR Field Descriptions

| Field | Description |
|---------------------|---|
| 0 SAD | Shadow Address. The SAD bit qualifies the address captured during an ECC Event Error, Single Bit Correction, or State Machine operation. The SAD register is not writable. 0 Address Captured is from Main Array Space. 1 Address Captured is from Shadow Array Space. |
| 1–13 | Reserved |
| 14–28 ADDR[17:3] | Address. The FLASH_x_AR provides the first failing address in the event of ECC event error (FLASH_x_MCR[EER] set), single bit correction (FLASH_x_MCR[SBC] set), as well as providing the address of a failure that may have occurred in a state machine operation (FLASH_x_MCR[PEG] cleared). ECC event errors take priority over single bit corrections, which take priority over state machine errors. This is especially valuable in the event of a RWW operation, where the read senses an ECC error or single bit correction, and the state machine fails simultaneously. This address is always a Double Word address that selects 64 bits. The FLASH_x_AR is writable, and can be used in the UTEST ECC Logic Check. If the ECC logic check is enabled (FLASH_x_UT0[EIE] = 1) then the FLASH_x_AR will not update for ECC event error, single bit correction or state machine errors. If FLASH_x_MCR[EER] or FLASH_x_MCR[SBC] are set, the FLASH_x_AR is locked from writing. FLASH_x_MCR[PEG] does not affect the writability of the FLASH_x_AR. |
| 29–31 | Reserved |

12.2.2.8 Flash Bus Interface Configuration Register (FLASH_BIUCR)

FLASH_BIUCR is used to specify operation of the dual-flash controller. This register must not be written while executing from flash.

Offset: 0x001C

Access: User read/write

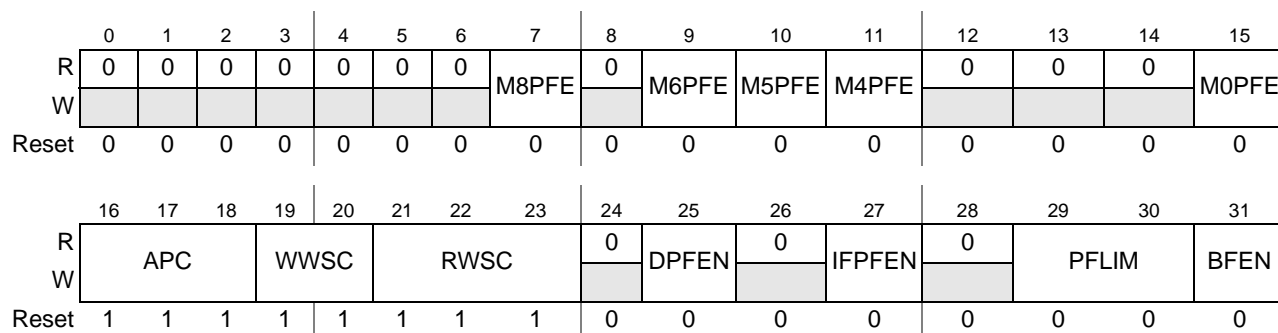

Figure 12-10. Flash Bus Interface Configuration Register (FLASH_BIUCR)

Table 12-12. FLASH_BIUCR Field Descriptions

| Field | Description | | | | | | | | | | | | | | | | |
|----------------|--|-----------|--------|---|---------|---|--------------|---|--------------|---|--------------|---|--------|---|--------|---|---------|
| 0–15 MnPFEN | <p>Master n prefetch enable, where n represents the master ID number in the table below. These bits are used to control whether prefetching may be triggered based on the master ID of a requesting master. These bits are cleared by hardware reset.</p> <p>0 No prefetching may be triggered by this master 1 Prefetching may be triggered by this master</p> <p>Note: These bits refer to the master ID, not the master port number, as shown in the following:</p> <table border="1" style="margin-left: 40px;"> <thead> <tr> <th>Master ID</th> <th>Module</th> </tr> </thead> <tbody> <tr> <td>0</td> <td>Z7 Core</td> </tr> <tr> <td>1</td> <td>– reserved –</td> </tr> <tr> <td>2</td> <td>– reserved –</td> </tr> <tr> <td>3</td> <td>– reserved –</td> </tr> <tr> <td>4</td> <td>eDMA_A</td> </tr> <tr> <td>5</td> <td>eDMA_B</td> </tr> <tr> <td>6</td> <td>FlexRay</td> </tr> </tbody> </table> | Master ID | Module | 0 | Z7 Core | 1 | – reserved – | 2 | – reserved – | 3 | – reserved – | 4 | eDMA_A | 5 | eDMA_B | 6 | FlexRay |
| Master ID | Module | | | | | | | | | | | | | | | | |
| 0 | Z7 Core | | | | | | | | | | | | | | | | |
| 1 | – reserved – | | | | | | | | | | | | | | | | |
| 2 | – reserved – | | | | | | | | | | | | | | | | |
| 3 | – reserved – | | | | | | | | | | | | | | | | |
| 4 | eDMA_A | | | | | | | | | | | | | | | | |
| 5 | eDMA_B | | | | | | | | | | | | | | | | |
| 6 | FlexRay | | | | | | | | | | | | | | | | |
| 16–18 APC | <p>Address Pipelining Control. This field is used to control the number of cycles between pipelined access requests.</p> <p>It must be set to a value corresponding to the operating frequency of the flash. Higher operating frequencies require non-zero settings for this field for proper flash operation. This field is set to 0b111 by hardware reset.</p> <p>000 Accesses may be pipelined back-to-back 001 Access requests require one additional hold cycle 010 Access requests require two additional hold cycles ... 110 Access requests require six additional hold cycles 111 No address pipelining</p> <p>Note: The settings for APC and RWSC must be the same. Note: Valid settings are specified in product Data Sheet.</p> | | | | | | | | | | | | | | | | |

Table 12-12. FLASH_BIUCR Field Descriptions

| | |
|----------------|---|
| 19–20 WWSC | <p>Write Wait State Control - This field is used to control the number of wait-states to be added to the best-case flash array access time for writes. The best-case flash array access time for writes is two cycles. This field must be set to a value corresponding to the operating frequency of the flash. Higher operating frequencies require non-zero settings for this field for proper flash operation. This field is set to 0b11 by hardware reset.</p> <p>00 No additional wait-states are added 01 One additional wait-state is added 10 Two additional wait-states are added 11 Three additional wait-states are added</p> |
| 21–23 RWSC | <p>Read Wait State Control - This field is used to control the number of wait-states to be added to the best-case flash array access time for reads. The best-case flash array access time for reads is one cycle. This field must be set to a value corresponding to the operating frequency of the flash and the actual read access time of the flash. Higher operating frequencies require non-zero settings for this field for proper flash operation.</p> <p>This field is set to 0b111 by hardware reset. 000 No additional wait-states are added 001 One additional wait-state is added ... 111 Seven additional wait-states are added</p> <p>Note: The settings for APC and RWSC must be the same. Note: Valid settings are specified in the product Data Sheet.</p> |
| 24 | Reserved |
| 25 DPFEN | <p>Data Prefetch Enable - This field enables or disables prefetching initiated by a data read access. This field is cleared by hardware reset.</p> <p>0 No prefetching is triggered by a data read access 1 Prefetching may be triggered by any data read access</p> |
| 26 | Reserved |
| 27 IPFEN | <p>Instruction Prefetch Enable - This bit enables or disables prefetching initiated by an instruction read access. This field is cleared by hardware reset.</p> <p>0 No prefetching is triggered by an instruction read access 1 Prefetching may be triggered by any instruction read access</p> |
| 28 | Reserved |
| 29–30 PFLIM | <p>Flash Prefetch Limit - This field controls the prefetch algorithm used by the flash prefetch controller. This field defines a limit on the maximum number of sequential prefetches which will be attempted between buffer misses. In all situations when enabled, only a single prefetch is initiated on each buffer miss or hit. This field is cleared by hardware reset.</p> <p>00 No prefetching or buffering is performed. 01 The referenced line is prefetched on a buffer miss, i.e., prefetch on miss. 1x The referenced line is prefetched on a buffer miss, or the next sequential line is prefetched on a buffer hit (if not already present), i.e., prefetch on miss or hit.</p> |
| 31 BFEN | <p>Flash Line Read Buffers Enable - This bit enables or disables line read buffer hits. It is also used to invalidate the buffers. This bit is cleared by hardware reset.</p> <p>0 The line read buffers are disabled from satisfying read requests, and all buffer valid bits are cleared. 1 The line read buffers are enabled to satisfy read requests on hits. Buffer valid bits may be set when the buffers are successfully filled.</p> |

12.2.2.9 Flash Bus Interface Access Protection Register (FLASH_BIUAPR)

This register is used to control bus master read and write access attributes to the flash array.

Offset: 0x0020

Access: User read/write

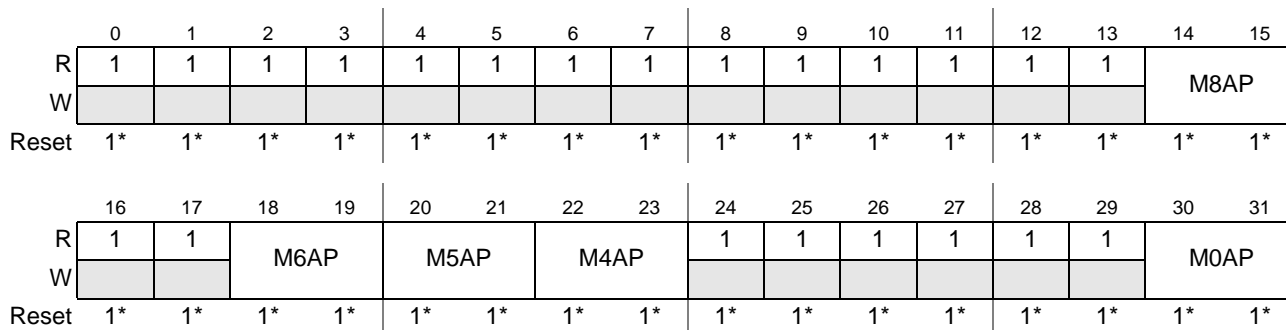

Figure 12-11. Flash Bus Interface Access Protection Register (FLASH_BIUAPR)

Table 12-13. FLASH_BIUAPR Bit Field Descriptions

| Field | Description | | | | | | | | | | | | | | | | | | | | |
|---------------------------------|--|-----------|--------|---|---------|---|--------------|---|--------------|---|--------------|---|--------|---|--------|---|---------|---|---|---|----------|
| 0–13 16–17 24–29 | Reserved | | | | | | | | | | | | | | | | | | | | |
| 14–15 18–23 30–31 MnAP | <p>Master <i>n</i> Access Protection, where <i>n</i> represents the master ID number in the table below. These fields are used to control whether read and write accesses to the flash are allowed based on the master ID of a requesting master.</p> <p>00 No accesses may be performed by this master 01 Only read accesses may be performed by this master 10 Only write accesses may be performed by this master 11 Both read and write accesses may be performed by this master</p> <p>Note: These bits refer to the master ID, not the master port number, as shown in the following:</p> <table border="1" style="margin-left: 40px;"> <thead> <tr> <th>Master ID</th> <th>Module</th> </tr> </thead> <tbody> <tr> <td>0</td> <td>Z7 Core</td> </tr> <tr> <td>1</td> <td>– reserved –</td> </tr> <tr> <td>2</td> <td>– reserved –</td> </tr> <tr> <td>3</td> <td>– reserved –</td> </tr> <tr> <td>4</td> <td>eDMA_A</td> </tr> <tr> <td>5</td> <td>eDMA_B</td> </tr> <tr> <td>6</td> <td>FlexRay</td> </tr> <tr> <td>7</td> <td>Reserved for EBI test (not for customer use)</td> </tr> <tr> <td>8</td> <td>Z7 Nexus</td> </tr> </tbody> </table> | Master ID | Module | 0 | Z7 Core | 1 | – reserved – | 2 | – reserved – | 3 | – reserved – | 4 | eDMA_A | 5 | eDMA_B | 6 | FlexRay | 7 | Reserved for EBI test (not for customer use) | 8 | Z7 Nexus |
| Master ID | Module | | | | | | | | | | | | | | | | | | | | |
| 0 | Z7 Core | | | | | | | | | | | | | | | | | | | | |
| 1 | – reserved – | | | | | | | | | | | | | | | | | | | | |
| 2 | – reserved – | | | | | | | | | | | | | | | | | | | | |
| 3 | – reserved – | | | | | | | | | | | | | | | | | | | | |
| 4 | eDMA_A | | | | | | | | | | | | | | | | | | | | |
| 5 | eDMA_B | | | | | | | | | | | | | | | | | | | | |
| 6 | FlexRay | | | | | | | | | | | | | | | | | | | | |
| 7 | Reserved for EBI test (not for customer use) | | | | | | | | | | | | | | | | | | | | |
| 8 | Z7 Nexus | | | | | | | | | | | | | | | | | | | | |

12.2.2.10 Flash Bus Interface Configuration Register 2 (FLASH_BIUCR2)

NOTE

A reset value of 1* in [Figure 12-12](#) indicates that the reset value of these registers is determined by Flash values in the shadow block. An erased shadow block causes the reset value to be 1.

Offset: 0x0024

Access: User read/write

| | | | | | | | | | | | | | | | | |
|-------|-------|----|----|----|----|----|----|----|----|----|----|----|----|----|----|----|
| | 0 | 1 | 2 | 3 | 4 | 5 | 6 | 7 | 8 | 9 | 10 | 11 | 12 | 13 | 14 | 15 |
| R | LBCFG | | | | 0 | 0 | 0 | 0 | 0 | 0 | 0 | 0 | 0 | 0 | 0 | 0 |
| W | | | | | | | | | | | | | | | | |
| Reset | 1* | 1* | 1* | 1* | 1* | 1* | 1* | 1* | 1* | 1* | 1* | 1* | 1* | 1* | 1* | 1* |

| | | | | | | | | | | | | | | | | |
|-------|----|----|----|----|----|----|----|----|----|----|----|----|----|----|----|----|
| | 16 | 17 | 18 | 19 | 20 | 21 | 22 | 23 | 24 | 25 | 26 | 27 | 28 | 29 | 30 | 31 |
| R | 0 | 0 | 0 | 0 | 0 | 0 | 0 | 0 | 0 | 0 | 0 | 0 | 0 | 0 | 0 | 0 |
| W | | | | | | | | | | | | | | | | |
| Reset | 1* | 1* | 1* | 1* | 1* | 1* | 1* | 1* | 1* | 1* | 1* | 1* | 1* | 1* | 1* | 1* |

Figure 12-12. Flash Bus Interface Configuration Register 2 (FLASH_BIUCR2)

Table 12-14. FLASH_BIUCR2 Bit Field Descriptions

| Field | Description |
|-----------------|--|
| 0–1 LBCFG_P0 | <p>Line Buffer Configuration. This field controls the configuration of all the line buffers in the flash bus interface unit. The buffers can be organized as a “pool” of available resources, or with a fixed partition between instruction and data buffers.</p> <p>In all cases, when a buffer miss occurs, it is allocated to the least-recently-used buffer within the group and the just-fetched entry then marked as most-recently-used. If the flash access is for the next-sequential line, the buffer is not marked as most-recently-used until the given address produces a buffer hit.</p> <p>This field is initialized by hardware reset to the value contained in address 0x00FF_FE00 of the shadow block of the flash array. The initial value is given in Table 12-2.</p> <p>This field controls the configuration of both the 4 x 128 and 4 x 256 line buffers.</p> <p>00 All four buffers are available for any flash access, i.e., there is no partitioning of the buffers based on the access type. 01 Reserved 10 The buffers are partitioned into two groups with buffers 0 and 1 allocated for instruction fetches and buffers 2 and 3 for data accesses. 11 The buffers are partitioned into two groups with buffers 0,1,2 allocated for instruction fetches and buffer 3 for data accesses.</p> |
| 2–31 | Reserved |

NOTE

A reset value of 1* in Figure 12-13 indicates that the reset value of these registers is determined by Flash values in the shadow block. An erased shadow block causes the reset value to be 1.

Offset: 0x0024 Access: User read/write

| | | | | | | | | | | | | | | | | |
|-------|-------|----|----|----|----|----|----|----|----|----|----|----|----|----|----|----|
| | 0 | 1 | 2 | 3 | 4 | 5 | 6 | 7 | 8 | 9 | 10 | 11 | 12 | 13 | 14 | 15 |
| R | LBCFG | | 0 | 0 | 0 | 0 | 0 | 0 | 0 | 0 | 0 | 0 | 0 | 0 | 0 | 0 |
| W | | | | | | | | | | | | | | | | |
| Reset | 1* | 1* | 1* | 1* | 1* | 1* | 1* | 1* | 1* | 1* | 1* | 1* | 1* | 1* | 1* | 1* |

| | | | | | | | | | | | | | | | | |
|-------|----|----|----|----|----|----|----|----|----|----|----|----|----|----|----|----|
| | 16 | 17 | 18 | 19 | 20 | 21 | 22 | 23 | 24 | 25 | 26 | 27 | 28 | 29 | 30 | 31 |
| R | 0 | 0 | 0 | 0 | 0 | 0 | 0 | 0 | 0 | 0 | 0 | 0 | 0 | 0 | 0 | 0 |
| W | | | | | | | | | | | | | | | | |
| Reset | 1* | 1* | 1* | 1* | 1* | 1* | 1* | 1* | 1* | 1* | 1* | 1* | 1* | 1* | 1* | 1* |

Figure 12-13. Flash Bus Interface Configuration Register 2 (FLASH_BIUCR2)

12.2.2.11 User Test Register 0 (FLASH_x_UT0)

The User Test Register 0 (FLASH_x_UT0) provides a means to control UTest. The UTest mode gives the users of the flash module the ability to perform test features on the flash. This register is only writable when the flash is put into UTest mode by writing a passcode.

Offset: 0x003C / 0x403C Access: User read/write

| | | | | | | | | | | | | | | | | |
|-------|-----|------|---|---|---|---|---|---|-----|---|----|----|----|----|----|----|
| | 0 | 1 | 2 | 3 | 4 | 5 | 6 | 7 | 8 | 9 | 10 | 11 | 12 | 13 | 14 | 15 |
| R | UTE | SCBE | 0 | 0 | 0 | 0 | 0 | 0 | DSI | | | | | | | |
| W | | | | | | | | | | | | | | | | |
| Reset | 0 | 0 | 0 | 0 | 0 | 0 | 0 | 0 | 0 | 0 | 0 | 0 | 0 | 0 | 0 | 0 |

| | | | | | | | | | | | | | | | | |
|-------|----|----|----|----|----|----|----|----|----|----|-----|-----|-----|-----|-----|-----|
| | 16 | 17 | 18 | 19 | 20 | 21 | 22 | 23 | 24 | 25 | 26 | 27 | 28 | 29 | 30 | 31 |
| R | 0 | 0 | 0 | 0 | 0 | 0 | 0 | 0 | EA | 0 | MRE | MRV | EIE | AIS | AIE | AID |
| W | | | | | | | | | | | | | | | | |
| Reset | 0 | 0 | 0 | 0 | 0 | 0 | 0 | 0 | 1 | 0 | 0 | 0 | 0 | 0 | 0 | 1 |

Figure 12-14. User Test Register 0 (FLASH_x_UT0)

Table 12-15. FLASH_x_UT0 Field Descriptions

| Field | Description |
|-------------|---|
| 0 UTE | <p>UTest Enable. This status bit gives indication when UTest is enabled. All bits in FLASH_x_UT0, FLASH_x_UT1, FLASH_x_UT2 are locked when this bit is 0. This bit is not writeable to a 1, but may be cleared. The reset value is 0. The method to set this bit is to provide a password, and if the password matches, the UTE bit is set to reflect the status of enabled, and is enabled until it is cleared by a register write. The UTE password will only be accepted if FLASH_x_MCR[PGM] = 0 and FLASH_x_MCR [ERS] = 0 (program and erase are not being requested). UTE can only be cleared if FLASH_x_UT0[AID] = 1, FLASH_x_UT0[AIE] and FLASH_x_UT0[EIE] = 0. While clearing UTE, writes to set AIE or set EIE will be ignored. For UTE, the password 0xF9F9_9999 must be written to the FLASH_x_UT0 register.</p> |
| 1 SCBE | <p>Single Bit Correction Enable. SBC enables Single Bit Correction results to be observed in FLASH_x_MCR[SBC]. Also is used as an enable for interrupt signals created by the c90fl module (see c90fl Integration Guide). ECC corrections that occur when SBCE is cleared will not be logged.</p> <p>0 Single Bit Corrections observation is disabled. 1 Single Bit Correction observation is enabled.</p> |
| 2–7 | Reserved |
| 8–15 DSI | <p>Data Syndrome Input. These bits enable checks of ECC logic by allowing check bits to be input into the ECC logic and then read out by doing array reads or array integrity checks. The DSI[7:0] correspond to the 8 ECC check bits on a double word.</p> |
| 16–23 | Reserved |
| 24 EA | <p>ECC Algorithm. EA is a status bit that provides information about the ECC algorithm used within the Flash. Either a modified Hamming code is used, or a modified Hsiao code is used.</p> <p>0 ECC is implemented with a modified Hamming algorithm. 1 ECC is implemented with a modified Hsiao algorithm.</p> |
| 25 | Reserved |
| 26 MRE | <p>Margin Read Enable. MRE combined with MRV enables Factory Margin Reads to be done. Margin reads are only active during Array Integrity Checks. Normal user reads are not affected by MRE. MRE is not writable if AID is low.</p> <p>0 Margin reads are not enabled. 1 Margin reads are enabled during Array Integrity Checks.</p> |
| 27 MRV | <p>Margin Read Value. MRV selects the margin level that is being checked. Margin can be checked to an erased level (MRV = 1) or to a programmed level (MRV = 0). In order for this value to be valid, MRE must also be set. MRV is not writable if AID is low.</p> <p>0 Zero's margin reads are requested. 1 One's margin reads are requested.</p> |
| 28 EIE | <p>ECC Data Input Enable. EIE enables the input registers (DSI and DAI) to be the source of data for the array. This is useful in the ECC logic check. If this bit is set, data read through a BIU read request will be from the DSI and DAI registers when an address match is achieved to the FLASH_x_AR. EIE is not simultaneously writable to a 1 as UTI is being cleared to a 0.</p> <p>0 Data read is from the flash array. 1 Data read is from the DSI and DAI registers.</p> |
| 29 AIS | <p>Array Integrity Sequence. AIS determines the address sequence to be used during array integrity checks. The default sequence (AIS = 0) is meant to replicate sequences normal “user” code follows, and thoroughly checks the read propagation paths. This sequence is proprietary. The alternative sequence (AIS = 1) is just logically sequential.</p> <p>It should be noted that the time to run a sequential sequence is significantly shorter than the time to run the proprietary sequence. If MRE is set, AIS has no effect.</p> <p>0 Array integrity sequence is proprietary sequence. 1 Array integrity sequence is sequential.</p> |

Table 12-15. FLASH_x_UT0 Field Descriptions (continued)

| Field | Description |
|-----------|--|
| 30 AIE | <p>Array Integrity Enable. AIE set to one starts the array integrity check done on all selected and unlocked blocks. The address sequence selected is determined by AIS, and the MISR (UM0 through UM4) can be checked after the operation is complete, to determine if a correct signature is obtained. Once an Array Integrity operation is requested (AIE = 1), it may be terminated by clearing AIE if the operation has finished (AID = 1) or aborted by clearing AIE if the operation is ongoing (AID = 0). AIE is not simultaneously writable to a 1 as UTI is being cleared to a 0.</p> <p>0 Array integrity checks are not enabled. 1 Array integrity checks are enabled.</p> |
| 31 AID | <p>Array Integrity Done. AID is cleared upon an Array integrity check being enabled (to signify the operation is ongoing). Once completed, AID is set to indicate that the array integrity check is complete. At this time the MISR (UMR registers) can be checked. AID can not be written, and is status only.</p> <p>0 Array integrity check is ongoing. 1 Array integrity check is done.</p> |

12.2.2.12 User Test Register 1 (FLASH_x_UT1)

The User Test Register 1 (FLASH_x_UT1) provides added controllability to UTest.

Offset: 0x0040 / 0x4040

Access: User read/write

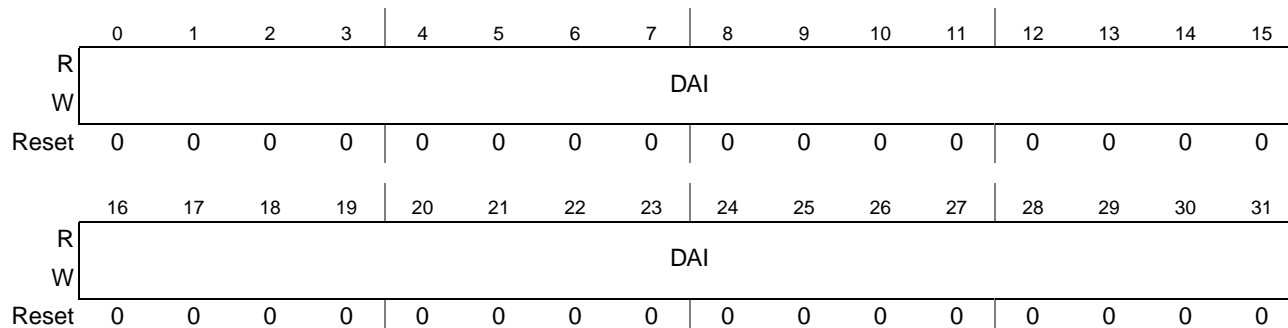

Figure 12-15. User Test Register 1 (FLASH_x_UT1)

Table 12-16. FLASH_x_UT1 Field Descriptions

| Field | Description |
|-------------|---|
| 0–31 DAI | Data Array Input. These bits enable checks of ECC logic by allowing data bits to be input into the ECC logic and then read out by doing array reads or array integrity checks. The DAI[31:0] correspond to the 32 Array bits representing Word 0 of the double word selected in the FLASH_x_AR. |

12.2.2.13 User Test Register 2 (FLASH_x_UT2)

Offset: 0x0044 / 0x4044

Access: User read/write

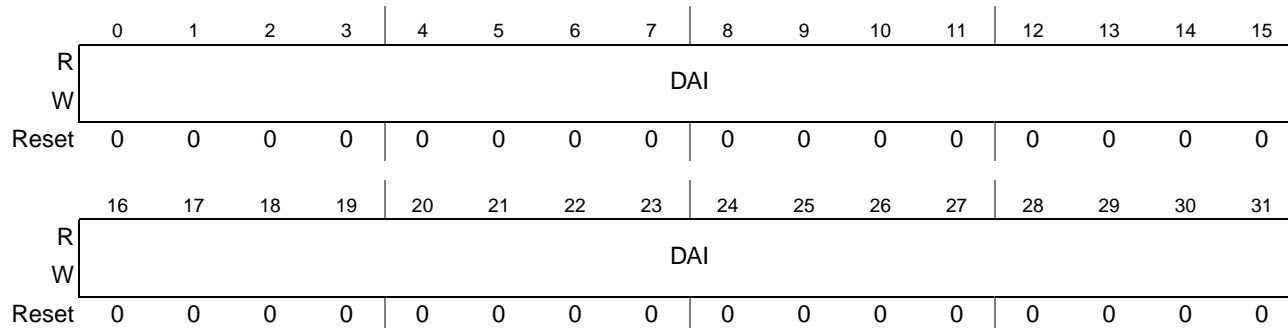

Figure 12-16. User Test Register 2 (FLASH_x_UT2)

Table 12-17. FLASH_x_UT2 Field Descriptions

| Field | Description |
|-------------|--|
| 0–31 DAI | Data Array Input. These bits enable checks of ECC logic by allowing data bits to be input into the ECC logic and then read out by doing array reads or array integrity checks. The DAI[63:32] correspond to the 32 Array bits representing Word 1 of the double word selected in the FLASH_x_AR. |

12.3 Functional Description

12.3.1 Flash User Mode

In user mode the flash module can be read and written (register writes and interlock writes), programmed or erased. The following sub-sections define all actions that can be performed in user mode.

12.3.2 Flash Read and Write

The default state of the flash module is read. The main and shadow address space can be read only in the read state. The module configuration register (FLASH_x_MCR) is always available for read. The flash module enters the read state on reset. The flash module is in the read state under these conditions:

- The read state is active when PGM = 1 or ERS = 1 in the FLASH_x_MCR and high-voltage operation is ongoing (read while write).

NOTE

Reads done to the partition(s) being operated on (either erased or programmed) will result in an error and the RWE bit in the FLASH_x_MCR will be set.

- The read state is active when PGM = 1 and PSUS = 1 in the FLASH_x_MCR (program suspend).
- The read state is active when ERS = 1 and ESUS = 1 and PGM = 0 in the FLASH_x_MCR (erase suspend).

In flash user mode, registers can be written. Array can be written to do interlock writes.

Interlock writes attempted to invalid locations (due to blocks that do not exist in non 2ⁿ array sizes), will result in an interlock occurring, but attempts to program or erase these blocks will not occur since they are forced to be locked.

12.3.3 Read While Write (RWW)

The flash core is divided into partitions. Partitions are always comprised of two or more blocks. Partitions are used to determine read-while-write (RWW) groupings. While a write (program or erase) is being done within a given partition, a read can be simultaneously executed to any other partition. Partitions are listed in [Table 12-1](#).

For each Flash array, the high address space of each RWW partition is physically comprised of two 256K blocks as shown in [Figure 12-1](#). However, because the high address space blocks are interleaved every 16 bytes between Flash array A and Flash array B, the practical size of the high address space RWW partitions is effectively four 256K blocks.

The shadow block has unique RWW restrictions described in [Section 12.3.6, Flash Shadow Block](#).

The FC is also divided into blocks to implement independent erase or program protection. The shadow block exists outside the normal address space and is programmed, erased, and read independently of the other blocks. The shadow block is included to support systems that require NVM for security or system initialization information.

A software mechanism is provided to independently lock or unlock each block in high-, mid-, and low-address space against program and erase. Two hardware locks are also provided to enable/disable the FC for program/erase. See [Section 12.3.4.1, Software Locking](#), for more information.

12.3.4 Flash Programming

Programming changes the value stored in an array bit from logic 1 to logic 0 only. Programming cannot change a stored logic 0 to a logic 1. Addresses in locked/disabled blocks cannot be programmed. The user can program the values in any or all of four words within a page in a single program sequence. Word addresses are selected using bits 3:2 of the page-bound word.

Whenever a program operation occurs, ECC bits are programmed. ECC is handled on a 64-bit boundary. Thus, if only one word in any given 64-bit ECC segment is programmed, the adjoining word (in that segment) should not be programmed because ECC calculation has already completed for that 64-bit segment. Attempts to program the adjoining word will probably result in an operation failure. It is recommended that all programming operations be from 64 bits to 128 bits, and be 64-bit aligned. The programming operation should completely fill selected ECC segments within the page.

The program operation consists of the following sequence of events:

1. Change the value in the FLASH_x_MCR[PGM] bit from a 0 to a 1.

NOTE

Ensure the block that contains the address to be programmed is unlocked. See [Section 12.2.2.2, Low/Mid Address Space Block Locking Register \(FLASH_x_LMLR\)](#), [Section 12.2.2.3, High Address Space Block Locking Register \(FLASH_x_HLR\)](#), and [Section 12.2.2.4, Secondary Low/Mid Address Space Block Locking Register \(FLASH_x_SLMLR\)](#), for more information.

2. Write the first address to be programmed in the flash module with the program data. This write is referred to as a program data interlock write. An interlock write may be either be an aligned word or doubleword.
3. If more than one word or doubleword is to be programmed, write each additional address in the page with data to be programmed. This is referred to as a program data write. All unwritten data words default to 0xFFFF_FFFF.
4. Write a logic 1 to the FLASH_x_MCR[EHV] bit to start the internal program sequence or skip to step 9 to terminate.
5. Wait until the FLASH_x_MCR[DONE] bit goes high.
6. Confirm FLASH_x_MCR[PEG] = 1.
7. Write a logic 0 to the FLASH_x_MCR[EHV] bit.
8. If more addresses are to be programmed, return to step 2.
9. Write a logic 0 to the FLASH_x_MCR[PGM] bit to terminate the program sequence.

The program sequence is presented graphically in [Figure 12-17](#). The program suspend operation detailed in [Figure 12-17](#) is discussed in [Section 12.3.4.1.1, Flash Program Suspend/Resume](#).

The first write after a program is initiated determines the page address to be programmed. Program may be initiated with the 0 to 1 transition of the FLASH_x_MCR[PGM] bit or by clearing the FLASH_x_MCR[EHV] bit at the end of a previous program. This first write is referred to as an interlock write. If the program is not an erase-suspended program, the interlock write determines if the shadow or normal array space will be programmed and causes FLASH_x_MCR[PEAS] to be set/cleared.

NOTE

Only the first write after a program is initiated does the interlock write and all later writes only look at bits 2 and 3 of the address so be careful that all writes after the interlock write are for that same 128 bit section.

In the case of an erase-suspended program, the value in FLASH_x_MCR[PEAS], is retained from the erase.

An interlock write must be performed before setting FLASH_x_MCR[EHV]. The user may terminate a program sequence by clearing FLASH_x_MCR[PGM] prior to setting FLASH_x_MCR[EHV].

If multiple writes are done to the same location the data for the last write is used in programming.

While FLASH_x_MCR[DONE] is low, FLASH_x_MCR[EHV] is high, and FLASH_x_MCR[PSUS] is low, the user may clear FLASH_x_MCR[EHV], resulting in a program abort. A program abort forces the module to step 8 of the program sequence. An aborted program will result in FLASH_x_MCR[PEG] being set low, indicating a failed operation. The data space being operated on before the abort will contain indeterminate data. The user may not abort a program sequence while in program suspend.

NOTE

Aborting a program operation will leave the flash core addresses being programmed in an indeterminate data state. This may be recovered by executing an erase on the affected blocks.

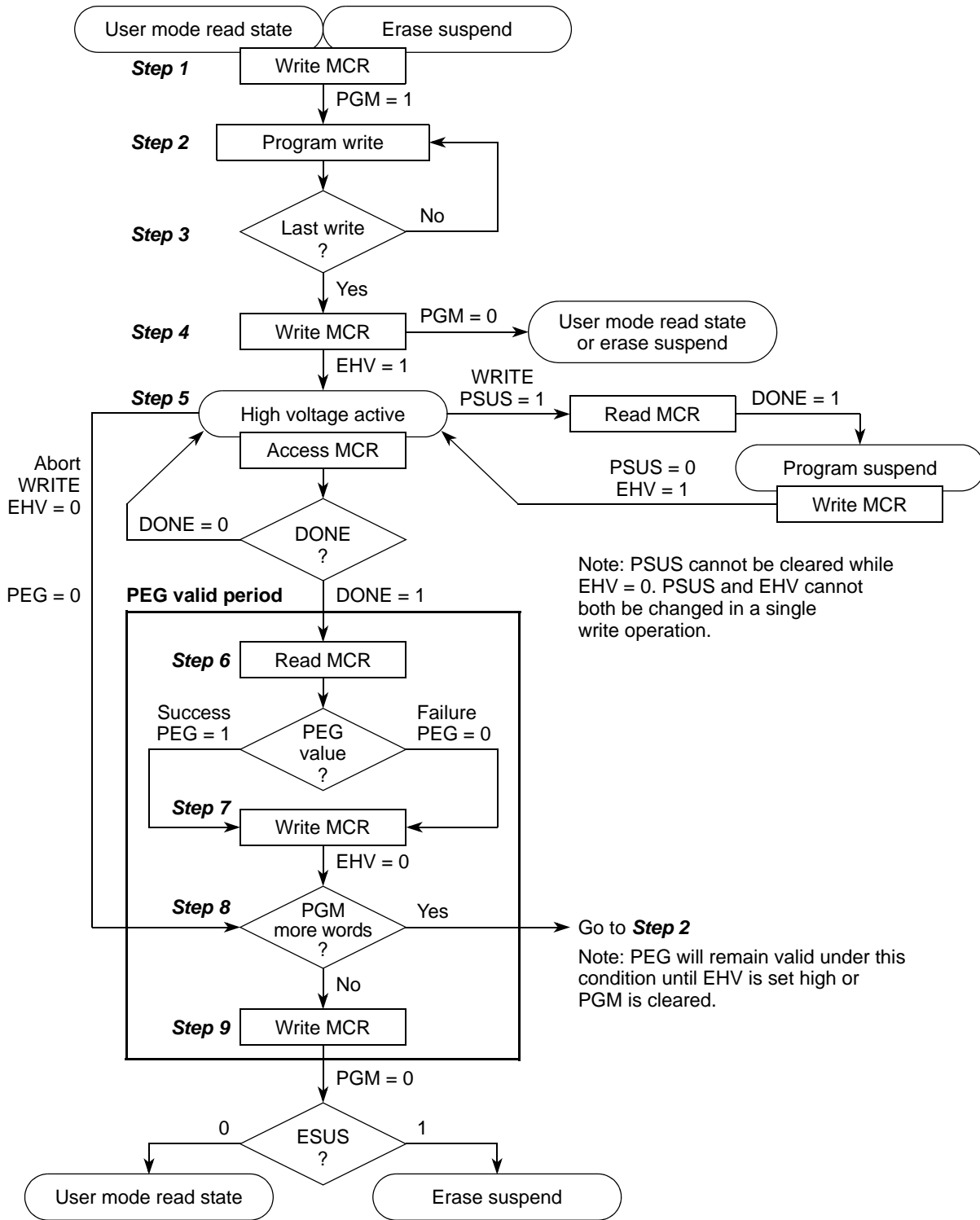

Figure 12-17. Program Sequence

12.3.4.1 Software Locking

A software mechanism is provided to independently lock/unlock each high-, mid-, and low-address space against program and erase.

Software locking is done through the FLASH_x_LMLR (low-/mid-address space block locking register), FLASH_x_SLMLR (secondary low-/mid-address space block locking register), or FLASH_x_HLR (high-address space block locking register). These can be written through register writes and read through register reads.

When the program/erase operations are enabled through hardware, software locks are enforced through doing register writes.

12.3.4.1.1 Flash Program Suspend/Resume

The program sequence may be suspended to allow read access to the flash core. It is not possible to erase or program during a program suspend. Interlock writes should not be attempted during program suspend.

A program suspend can be initiated by changing the value of the FLASH_x_MCR[PSUS] bit from a 0 to a 1. FLASH_x_MCR[PSUS] can be set high at any time when FLASH_x_MCR[PGM] and FLASH_x_MCR[EHV] are high. A 0 to 1 transition of FLASH_x_MCR[PSUS] causes the flash module to start the sequence to enter program suspend, which is a read state. The module is not suspended until FLASH_x_MCR[DONE] = 1. At this time flash core reads may be attempted. After it is suspended, the flash core may be read only. Reads to the blocks being programmed/erased return indeterminate data.

The program sequence is resumed by writing a logic 0 to FLASH_x_MCR[PSUS]. FLASH_x_MCR[EHV] must be set to a 1 before clearing FLASH_x_MCR[PSUS] to resume operation. When the operation resumes, the flash module continues the program sequence from one of a set of predefined points. This may extend the time required for the program operation.

12.3.5 Flash Erase

Erase changes the value stored in all bits of the selected blocks to logic 1. Locked or disabled blocks cannot be erased. If multiple blocks are selected for erase during an erase sequence, the blocks are erased sequentially starting with the lowest numbered block and terminating with the highest. Aborting an erase operation will leave the flash core blocks being erased in an indeterminate data state. This can be recovered by executing an erase on the affected blocks.

The erase sequence consists of the following sequence of events:

1. Change the value in the FLASH_x_MCR[ERS] bit from 0 to a 1.
2. Select the block, or blocks, to be erased by writing 1s to the appropriate registers in FLASH_x_LMSR or FLASH_x_HSR. If the shadow row is to be erased, this step may be skipped, and FLASH_x_LMSR and FLASH_x_HSR are ignored. For shadow row erase, see [Section 12.3.6, Flash Shadow Block](#), for more information.

NOTE

Lock and select are independent. If a block is selected and locked, no erase will occur. See [Section 12.2.2.2, Low/Mid Address Space Block Locking Register \(FLASH_x_LMLR\)](#), [Section 12.2.2.3, High Address Space Block Locking Register \(FLASH_x_HLR\)](#), and [Section 12.2.2.4, Secondary Low/Mid Address Space Block Locking Register \(FLASH_x_SLMLR\)](#), for more information.

3. Write to any address in flash within the flash array A or B (i.e. if you intend to erase a B block, you need to make sure the address is in array B). This is referred to as an erase interlock write.
4. Write a logic 1 to the FLASH_x_MCR[EHV] bit to start an internal erase sequence or skip to step 9 to terminate.
5. Wait until the FLASH_x_MCR[DONE] bit goes high.
6. Confirm FLASH_x_MCR[PEG] = 1.
7. Write a logic 0 to the FLASH_x_MCR[EHV] bit.
8. If more blocks are to be erased, return to step 2.
9. Write a logic 0 to the FLASH_x_MCR[ERS] bit to terminate the erase.

The erase sequence is presented graphically in [Figure 12-18](#). The erase suspend operation detailed in [Figure 12-18](#) is discussed in section [Section 12.3.5.1, Flash Erase Suspend/Resume](#).

After setting FLASH_x_MCR[ERS], one write (referred to as an interlock write) must be performed before FLASH_x_MCR[EHV] can be set to a 1. Data words written during erase sequence interlock writes are ignored. The user may terminate the erase sequence by clearing FLASH_x_MCR[ERS] before setting FLASH_x_MCR[EHV].

An erase operation may be aborted by clearing FLASH_x_MCR[EHV] assuming FLASH_x_MCR[DONE] is low, FLASH_x_MCR[EHV] is high, and FLASH_x_MCR[ESUS] is low. An erase abort forces the module to step 8 of the erase sequence. An aborted erase will result in FLASH_x_MCR[PEG] being set low, indicating a failed operation. The blocks being operated on before the abort contain indeterminate data. The user may not abort an erase sequence while in erase suspend.

NOTE

Aborting an erase operation will leave the flash core blocks being erased in an indeterminate data state. This may be recovered by executing an erase on the affected blocks.

12.3.5.1 Flash Erase Suspend/Resume

The erase sequence may be suspended to allow read access to the flash core. The erase sequence may also be suspended to program (erase-suspended program) the flash core. A program started during erase suspend can be suspended. One erase suspend and one program suspend are allowed at a time during an operation. It is not possible to erase during an erase suspend, or program during a program suspend. During suspend, all reads to flash core locations targeted for program and blocks targeted for erase return indeterminate data. Programming locations in blocks targeted for erase during erase-suspended program may result in corrupted data.

An erase suspend operation is initiated by setting the FLASH_x_MCR[ESUS] bit. FLASH_x_MCR[ESUS] can be set to a 1 at any time when FLASH_x_MCR[ERS] and FLASH_x_MCR[EHV] are high and FLASH_x_MCR[PGM] is low. A 0 to 1 transition of FLASH_x_MCR[ESUS] causes the flash module to start the sequence which places it in erase suspend. The user must wait until FLASH_x_MCR[DONE] = 1 before the module is suspended and further actions are attempted. After it is suspended, the array may be read or a program sequence may be initiated (erase-suspended program). Before initiating a program sequence the user must first clear FLASH_x_MCR[EHV]. If a program sequence is initiated, the value of the FLASH_x_MCR[PEAS] is not reset. These values are fixed at the time of the first interlock of the erase. Flash core reads from the blocks being erased while FLASH_x_MCR[ESUS] = 1 return indeterminate data.

The erase operation is resumed by clearing the FLASH_x_MCR[ESUS] bit. The flash continues the erase sequence from one of a set of predefined points. This can extend the time required for the erase operation.

CAUTION

In an erase-suspended program, programming flash locations in blocks which were being operated on in the erase may corrupt flash core data.

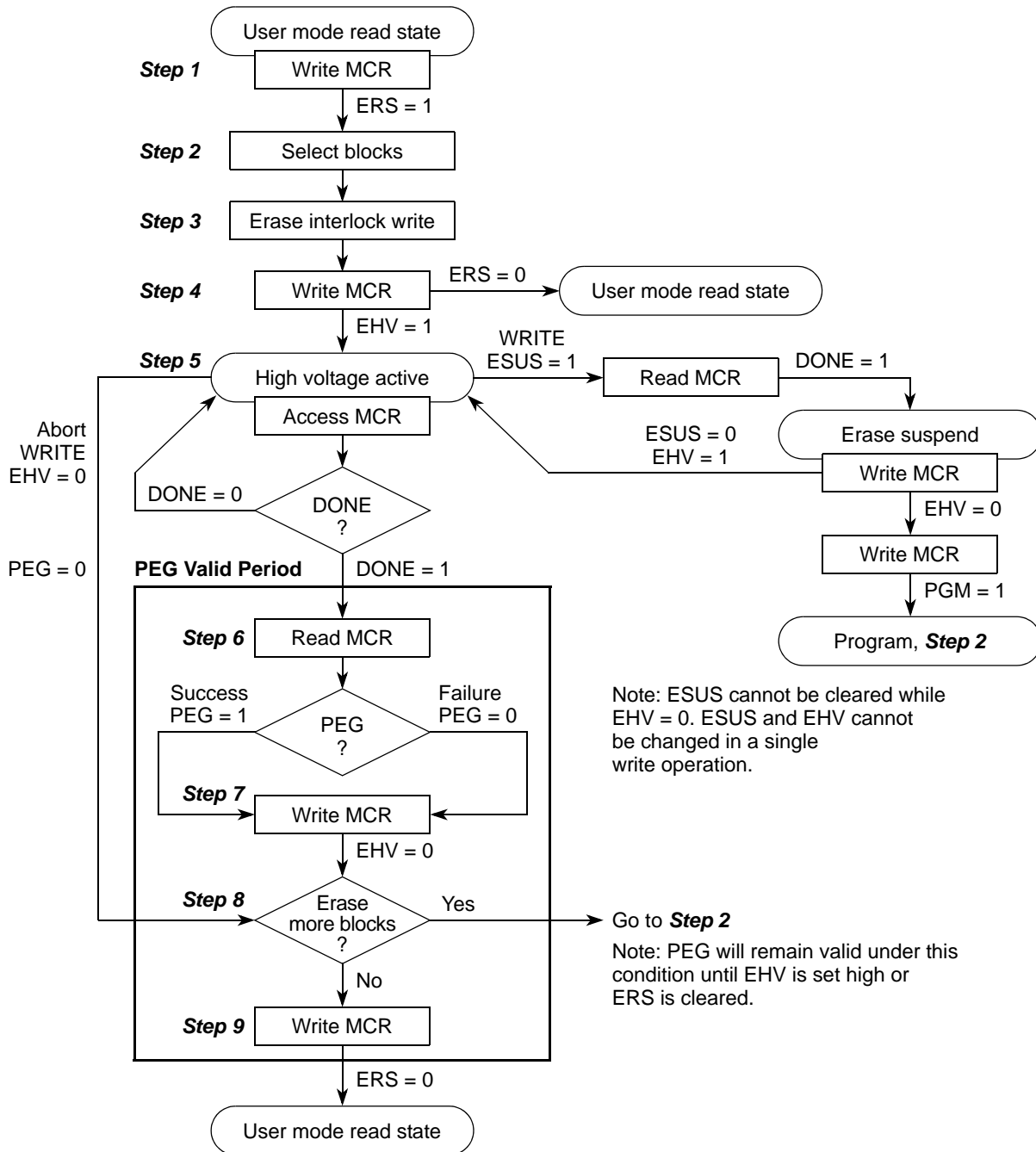

Figure 12-18. Erase Sequence

12.3.6 Flash Shadow Block

The flash shadow block is a memory-mapped block in the flash memory map. Program and erase of the shadow block are enabled when `FLASH_x_MCR[PEAS] = 1` only. After the user has begun an erase operation on the shadow block, the operation cannot be suspended to program the main address space and vice-versa. The user must terminate the shadow erase operation to program or erase the main address space.

NOTE

If an erase of user space is requested, and a suspend is done with attempts to erase suspend program shadow space, this attempted program will be directed to user space as dictated by the state of FLASH_x_MCR[PEAS]. Likewise an attempted erase suspended program of user space, while the shadow space is being erased, will be directed to shadow space as dictated by the state of FLASH_x_MCR[PEAS].

The shadow block cannot use the RWW feature. After an operation is started in the shadow block, a read cannot be done to the shadow block, or any other block. Likewise, after an operation is started in a block in low-/mid-/high-address space, a read cannot be done in the shadow block.

The shadow block contains information about how the lock registers are reset.

The shadow block may be locked/unlocked against program or erase by using the FLASH_x_LMLR or FLASH_x_SLMLR discussed in [Section 12.2.2, Register Descriptions](#).

WARNING

If the shadow flash block is erased without reprogramming a new valid password and censorship control word before a reset occurs it will contain an illegal password and the debug port will be inaccessible. Also, if code does not exist in the first bootable region of the internal flash to reprogram the shadow flash with the proper censorship control word and password, the device will be in a censored state and may no longer be usable.

Programming the shadow row has similar restrictions to programming the array in terms of how ECC is calculated. See [Section 12.3.4, Flash Programming](#), for more information. Only one program is allowed per 64 bit ECC segment between erases. Erase of the shadow row is done similarly as an array erase. See [Section 12.3.5, Flash Erase](#), for more information.

12.3.7 Flash Reset

A reset is the highest priority operation for the flash and terminates all other operations.

The flash uses reset to initialize register and status bits to their default reset values. If the flash is executing a program or erase operation and a reset is issued, the operation will be aborted and the flash will disable the high voltage logic without damage to the high-voltage circuits. Reset aborts all operations and forces the flash into user mode ready to receive accesses.

After reset is negated, register accesses can be performed, although it should be noted that registers that require updating from shadow information, or other inputs, cannot read updated until flash exits reset.

Chapter 13

Core (e200z7) Overview

13.1 Overview

The PXR40 is a dual-issue, 32-bit PowerPC Book E compliant design with 64-bit general purpose registers (GPRs). PowerPC Book E floating-point instructions are not supported in hardware, but are trapped and may be emulated by software.

An Embedded Floating-point APU is provided to support real-time single-precision embedded numerics operations using the general-purpose registers.

A second generation Signal Processing Extension APU is provided to support real-time SIMD fixed point and single-precision, embedded numerics operations using the general-purpose registers. All arithmetic instructions that execute in the core operate on data in the general purpose registers (GPRs). The GPRs are 64-bits in order to support vector instructions defined by the SPE2 APU. These instructions operate on 8-bit, 16-bit or 32-bit data types, and deliver vector and scalar results.

In addition to the base PowerPC Book E instruction set support, the PXR40 core also implements the VLE (variable-length encoding) technology, providing improved code density. The VLE technology is further documented in “PowerPC VLE Definition, Version 1.03”, a separate document.

The PXR40 processor integrates a pair of integer execution units, a branch control unit, instruction fetch unit and load/store unit, and a multi-ported register file capable of sustaining six read and three write operations per clock. Most integer instructions execute in a single clock cycle. Branch target prefetching is performed by the branch unit to allow single-cycle branches in many cases.

The PXR40 contains a 16Kbyte Instruction Cache, a 16Kbyte Data Cache, as well as a Memory Management Unit. A Nexus Class 3+ module is also integrated.

13.2 Register Model

The figures below show the complete PXR40 register set for Supervisor and User Modes. The number to the right of the special-purpose registers (SPRs) is the decimal number used in the instruction syntax to access the register (for example, the integer exception register (XER) is SPR 1).

SUPERVISOR Mode Programmer's Model SPRs and GPRs

General Registers

| | |
|---------------------------|----------------------------------|
| Condition Register | General-Purpose Registers |
| CR | GPR0 |
| Count Register | GPR1 |
| CTR SPR 9 | ⋮ |
| Link Register | GPR31 |
| LR SPR 8 | |
| XER | Accumulator |
| XER SPR 1 | ACC |

Processor Control Registers

| | |
|--------------------------|--|
| Machine State | Hardware Implementation Dependent¹ |
| MSR | HID0 SPR 1008 |
| Processor Version | HID1 SPR 1009 |
| PVR SPR 287 | |
| Processor ID | System Version¹ |
| PIR SPR 286 | SVR SPR 1023 |

Debug Registers²

| | |
|----------------------------------|------------------------------------|
| Debug Control | Instruction Address Compare |
| DBCR0 SPR 308 | IAC1 SPR 312 |
| DBCR1 SPR 309 | IAC2 SPR 313 |
| DBCR2 SPR 310 | IAC3 SPR 314 |
| DBCR3 ¹ SPR 561 | IAC4 SPR 315 |
| DBCR4 ¹ SPR 563 | IAC5 SPR 565 |
| DBCR5 ¹ SPR 564 | IAC6 SPR 566 |
| DBCR6 ¹ SPR 603 | IAC7 SPR 567 |
| DBERC0 ¹ SPR 569 | IAC8 SPR 568 |
| DEVENT ¹ SPR 975 | Data Address Compare |
| DDAM ¹ SPR 576 | DAC1 SPR 316 |
| Debug Status | DAC2 SPR 317 |
| DBSR SPR 304 | Data Value Compare |
| Debug Counter¹ | DVC1 SPR 318 |
| DBCNT SPR 562 | DVC2 SPR 319 |

- 1 - These PXR40-specific registers may not be supported by other PowerPC processors
- 2 - Optional registers defined by the PowerPC Book-E architecture
- 3 - Read-only registers

Exception Handling/Control Registers

| | | |
|--------------------|--|---------------------------------------|
| SPR General | Save and Restore | Interrupt Vector Prefix |
| SPRG0 SPR 272 | SRR0 SPR 26 | IVPR SPR 63 |
| SPRG1 SPR 273 | SRR1 SPR 27 | Interrupt Vector Offset |
| SPRG2 SPR 274 | CSRR0 SPR 58 | IVOR0 SPR 400 |
| SPRG3 SPR 275 | CSRR1 SPR 59 | IVOR1 SPR 401 |
| SPRG4 SPR 276 | DSRR0 ¹ SPR 574 | ⋮ |
| SPRG5 SPR 277 | DSRR1 ¹ SPR 575 | ⋮ |
| SPRG6 SPR 278 | MCSRR0 ¹ SPR 570 | IVOR15 SPR 415 |
| SPRG7 SPR 279 | MCSRR1 ¹ SPR 571 | IVOR32 ¹ SPR 528 |
| SPRG8 SPR 604 | Exception Syndrome | ⋮ |
| SPRG9 SPR 605 | ESR SPR 62 | IVOR35 ¹ SPR 531 |
| User SPR | Machine Check Syndrome Register | Machine Check Address Register |
| USPRG0 SPR 256 | MCSR SPR 572 | MCAR SPR 573 |
| | Data Exception Address | BTB Register |
| | DEAR SPR 61 | BTB Control ¹ |
| | Timers | BUCSR SPR 1013 |
| | Time Base (writeonly) | |
| | TBL SPR 284 | |
| | TBU SPR 285 | |
| | Decrementer | |
| | DEC SPR 22 | |
| | DECAR SPR 54 | |

Control and Status

| |
|-------------|
| TCR SPR 340 |
| TSR SPR 336 |

SPE/EFPU Registers

| |
|---|
| SPE/EFPU APU Status and Control Register |
| SPEFSCR SPR 512 |

Memory Management Registers

| | | |
|-------------------------------|-------------------|------------------------------------|
| MMU Assist¹ | Process ID | Control & Configuration |
| MAS0 SPR 624 | PID0 SPR 48 | MMUCSR0 SPR 1012 |
| MAS1 SPR 625 | | MMUCFG SPR 1015 |
| MAS2 SPR 626 | | TLB0CFG SPR 688 |
| MAS3 SPR 627 | | TLB1CFG SPR 689 |
| MAS4 SPR 628 | | |
| MAS6 SPR 630 | | |

Cache Registers

| | |
|--|----------------------------------|
| Cache Configuration (Read-only) | Cache Control¹ |
| L1CFG0 SPR 515 | L1CSR0 SPR 1010 |
| L1CFG1 SPR 516 | L1CSR1 SPR 1011 |
| | L1FINV0 SPR 1016 |
| | L1FINV1 SPR 959 |

Supervisor Mode Programmer's Model DCRs and PMRs

Performance Monitor Registers¹

| Control | | User Control (read-only) | | Counters | |
|---------|---------|--------------------------|---------|----------|--------|
| PMGC0 | PMR 400 | UPMGC0 | PMR 384 | PMC0 | PMR 16 |
| PMLCa0 | PMR 144 | UPMLCa0 | PMR 128 | PMC1 | PMR 17 |
| PMLCa1 | PMR 145 | UPMLCa1 | PMR 129 | PMC2 | PMR 18 |
| PMLCa2 | PMR 146 | UPMLCa2 | PMR 130 | PMC3 | PMR 19 |
| PMLCa3 | PMR 147 | UPMLCa3 | PMR 131 | | |
| PMLCb0 | PMR 272 | UPMLCb0 | PMR 256 | | |
| PMLCb1 | PMR 273 | UPMLCb1 | PMR 257 | | |
| PMLCb2 | PMR 274 | UPMLCb2 | PMR 258 | | |
| PMLCb3 | PMR 275 | UPMLCb3 | PMR 259 | | |

User Counters (read-only)

| | |
|-------|-------|
| UPMC0 | PMR 0 |
| UPMC1 | PMR 1 |
| UPMC2 | PMR 2 |
| UPMC3 | PMR 3 |

PSU Registers¹

| PSU | |
|-------|---------|
| PSCR | DCR 272 |
| PSSR | DCR 273 |
| PSHR | DCR 274 |
| PSLR | DCR 275 |
| PSCTR | DCR 276 |
| PSUHR | DCR 277 |
| PSULR | DCR 278 |

¹ - These PXR40-specific registers may not be supported by other PowerPC processors

Cache Access Registers¹

| | |
|---------|---------|
| CDACNTL | DCR 351 |
| CDADATA | DCR 350 |

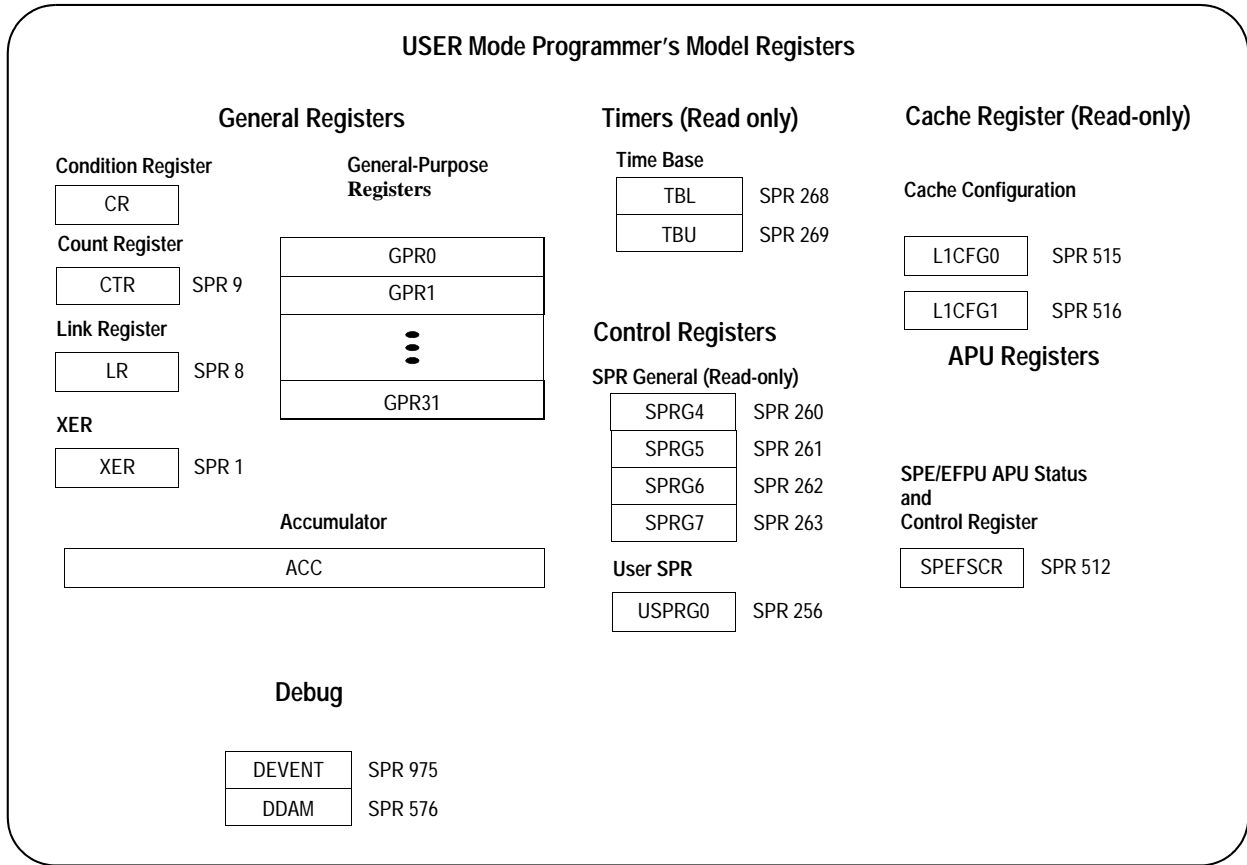

13.3 Cache

This section lists the most commonly used registers, instructions, and features of Cache. For a complete listing of all registers and features refer to *z759n3 Core Reference Manual*.

13.3.1 Cache Overview

The PXR40 supports a pair of 16Kbyte, 4-way set-associative, split instruction and data caches with a 32-byte line size. The caches improve system performance by providing low-latency data to the PXR40 instruction and data pipelines, which decouples processor performance from system memory performance. The caches are virtually indexed and physically tagged.

Instruction and data addresses from the processor to the caches are virtual addresses used to index the cache array. The MMU provides the virtual to physical translation for use in performing the cache tag compare. If the physical address matches a valid cache tag entry, the access hits in the cache. For a read operation, the cache supplies the data to the processor, and for a write operation, the data from the processor updates the cache. If the access does not match a valid cache tag entry (misses in the cache) or a write access must be written through to memory, the cache performs a bus cycle on the system bus.

13.3.2 Cache Registers

13.3.2.1 L1 Cache Control and Status Register 0 (L1CSR0)

The L1 Cache Control and Status Register 0 (L1CSR0) is a 32-bit register used for general control of the data cache as well as providing general control over disabling ways in both caches. The L1CSR0 register is accessed using a **mfscr** or **mtscr** instruction. The SPR number for L1CSR0 is 1010 in decimal. The L1CSR0 register is shown below.

| | | | | | | | | | | | | | | | | | | | | | | | | | | | | | | | |
|-----|-----|---|------|------|---|-------|------|---|-------|-------|------|------|-------|-------|------|----|--------|-------|-------|-----|----|----|----|----|----|----|----|----|----|----|----|
| WID | WDD | 0 | DCWM | DCWA | 0 | DCECE | DCEI | 0 | DCEDT | DCSLC | DCUL | DCLO | DCLFC | DCLOA | DCEA | 0 | DCBZ32 | DCABT | DCINV | DCE | | | | | | | | | | | |
| 0 | 1 | 2 | 3 | 4 | 5 | 6 | 7 | 8 | 9 | 10 | 11 | 12 | 13 | 14 | 15 | 16 | 17 | 18 | 19 | 20 | 21 | 22 | 23 | 24 | 25 | 26 | 27 | 28 | 29 | 30 | 31 |

SPR - 1010; Read/Write; Reset - 0x0

Figure 13-1. L1 Cache Control and Status Register 0 (L1CSR0)

The L1CSR0 bits are described below.

Table 13-1. L1CSR0 Field Descriptions

| Field | Description |
|------------|--|
| 0–3 WID | Way Instruction Disable. 0 The corresponding way in the instruction cache is available for replacement by instruction miss line fills. 1 The corresponding way instruction cache is not available for replacement by instruction miss line fills. Bit 0 corresponds to way 0. Bit 1 corresponds to way 1. Bit 2 corresponds to way 2. Bit 3 corresponds to way 3. The WID bits may be used for locking ways of the instruction cache, and also are used in determining the replacement policy of the instruction cache. |
| 4–7 WDD | Way Data Disable. 0 The corresponding way in the data cache is available for replacement by data miss line fills. 1 The corresponding way in the data cache is not available for replacement by data miss line fills. Bit 4 corresponds to way 0. Bit 5 corresponds to way 1. Bit 6 corresponds to way 2. Bit 7 corresponds to way 3. The WDD bits may be used for locking ways of the data cache, and also are used in determining the replacement policy of the data cache. |
| 8–10 | Reserved ¹ |

Table 13-1. L1CSR0 Field Descriptions (continued)

| Field | Description |
|----------------|--|
| 11 DCWM | <p>Data Cache Write Mode</p> <p>0 Data Cache operates in writethrough mode 1 Data Cache operates in copyback mode</p> <p>When set to writethrough mode, the “W” page attribute from the MMU is ignored and all writes are treated as writethrough required. When set, write accesses are performed in copyback mode unless the “W” page attribute from the MMU is set.</p> |
| 12–13 DCWA | <p>Data Cache Write Allocation Policy</p> <p>00 Cache line allocation on a cacheable write miss is disabled 01 Cache line allocation on a cacheable copyback write miss is enabled 10 Cache line allocation on a cacheable copyback or writethrough write miss is enabled 11 Reserved</p> <p>This field also controls merging of store data into the linefill buffer while a cache linefill is in progress. Store data will not be merged when write allocation is disabled. If DCWA is non-zero, store data merging is enabled regardless of the type (writethrough/copyback) of write.</p> |
| 14 | Reserved ¹ |
| 15 DCECE | <p>Data Cache Error Checking Enable</p> <p>0 Error Checking is disabled 1 Error Checking is enabled</p> |
| 16 DCEI | <p>Data Cache Error Injection</p> <p>0 Cache Error Injection is disabled 1 Parity errors will be purposefully injected into every byte subsequently written into the cache. The parity bit of each 8-bit data element written will be inverted. This includes writes due to store hits as well as writes due to cache line refills.</p> <p>DCEI will cause injection of errors regardless of the setting of DCECE, although reporting of errors will be masked while DCECE = 0.</p> |
| 17 | Reserved ¹ |
| 18–19 DCEDT | <p>Data Cache Error Detection Type</p> <p>00 Parity Error Detection is selected for both the tag and data arrays Reserved (defaults to DCEDT=01(EDC) actions) 01 EDC Error Detection is selected for the tag array and parity is selected for the data arrays 1x Reserved</p> |
| 20 DCSLC | <p>Data Cache Snoop Lock Clear</p> <p>0 Snoop has not invalidated a locked line 1 Snoop has invalidated a locked line</p> <p>Indicates a cache line lock was cleared by a snoop operation which caused an invalidation. This bit is set by hardware and will remain set until cleared by software writing 0 to this bit location.</p> |
| 21 DCUL | <p>Data Cache Unable to Lock</p> <p>Indicates a lock set instruction was not effective in locking a cache line. This bit is set by hardware on an “unable to lock” condition (other than lock overflows), and will remain set until cleared by software writing 0 to this bit location.</p> |

Table 13-1. L1CSR0 Field Descriptions (continued)

| Field | Description |
|---------------|--|
| 22 DCLO | Data Cache Lock Overflow Indicates a lock overflow (overlocking) condition occurred. This bit is set by hardware on an “overlocking” condition, and will remain set until cleared by software writing 0 to this bit location. |
| 23 DCLFC | Data Cache Lock Bits Flash Clear When written to a ‘1’, a cache lock bits flash clear operation is initiated by hardware. Once complete, this bit is reset to ‘0’. Writing a ‘1’ while a flash clear operation is in progress will result in an undefined operation. Writing a ‘0’ to this bit while a flash clear operation is in progress will be ignored. Cache Lock Bits Flash Clear operations require approximately 134 cycles to complete. Clearing occurs regardless of the enable (DCE) value. |
| 24 DCLOA | Data Cache Lock Overflow Allocate Set by software to allow a lock request to replace a locked line when a lock overflow situation exists. 0 Indicates a lock overflow condition will not replace an existing locked line with the requested line 1 Indicates a lock overflow condition will replace an existing locked line with the requested line |
| 25–26 DCEA | Data Cache Error Action 00 Error Detection causes Machine Check exception. 01 Error Detection causes Correction/Auto-invalidation. No machine check is generated for uncorrectable errors unless the cache line was locked and invalidated or is dirty. Dirty lines are not auto-invalidated. In EDC mode, correction is performed for single-bit tag errors, single-bit lock errors, and single or multi-bit dirty errors. In parity mode, tag and lock errors will result in invalidation of clean lines. For both modes, correction is performed for data errors by reloading of the line. 1x Reserved |
| 27 | Reserved ¹ |
| 28 DCBZ32 | Data Cache dcba , dcbz , operation length 0 dcba , dcbz , operations operate on an entire cache line 1 dcba , dcbz , operations operate on 32 bytes of a cache line Note: This bit is implemented for forward compatibility. Since cache lines are 32 bytes, this bit is ignored for dcba , dcbz , operations |
| 29 DCABT | Data Cache Operation Aborted Indicates a Cache Invalidate or a Cache Lock Bits Flash Clear operation was aborted prior to completion. This bit is set by hardware on an aborted condition, and will remain set until cleared by software writing 0 to this bit location. |

Table 13-1. L1CSR0 Field Descriptions (continued)

| Field | Description |
|-------------|---|
| 30 DCINV | <p>Data Cache Invalidate</p> <p>0 No cache invalidate</p> <p>1 Cache invalidation operation</p> <p>When written to a '1', a cache invalidation operation is initiated by hardware. Once complete, this bit is reset to '0'. Writing a '1' while an invalidation operation is in progress will result in an undefined operation. Writing a '0' to this bit while an invalidation operation is in progress will be ignored. Cache invalidation operations require approximately 134 cycles to complete. Invalidation occurs regardless of the enable (DCE) value.</p> <p>During cache invalidations, the parity check bits are written with a value dependent on the DCEDT selection. DCEDT should be written with the desired value for subsequent cache operation when DCINV is set to '1' for proper operation of the cache.</p> |
| 31 DCE | <p>Data Cache Enable</p> <p>0 Cache is disabled</p> <p>1 Cache is enabled</p> <p>When disabled, cache lookups are not performed for normal load or store accesses, or for snoop requests.</p> <p>Other L1CSR0 cache control operations are still available. Also, operation of the store buffer is not affected by DCE.</p> |

¹ These bits are not implemented and should be written with zero for future compatibility.

13.3.2.2 L1 Cache Control and Status Register 1 (L1CSR1)

The L1 Cache Control and Status Register 1 (L1CSR1) is a 32-bit register used for general control of the instruction cache. The L1CSR1 register is accessed using a **mf spr** or **mt spr** instruction. The SPR number for L1CSR0 is 1011 in decimal. The L1CSR1 register is shown below.

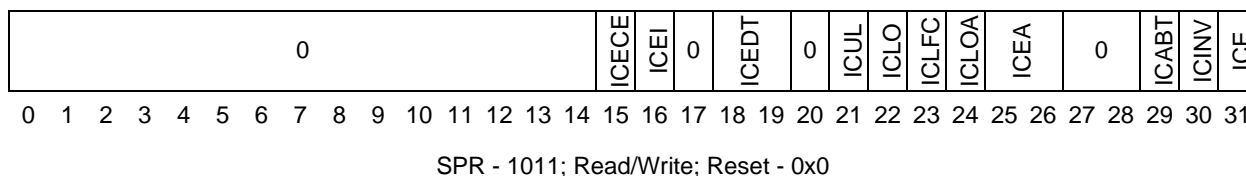

Figure 13-2. L1 Cache Control and Status Register 1 (L1CSR1)

The L1CSR1 bits are described below.

Table 13-2. L1CSR1 Field Descriptions

| Field | Description |
|-------------|---|
| 0–14 | Reserved ¹ |
| 15 ICECE | <p>Instruction Cache Error Checking Enable</p> <p>0 Error Checking is disabled</p> <p>1 Error Checking is enabled</p> |

Table 13-2. L1CSR1 Field Descriptions (continued)

| Field | Description |
|----------------|--|
| 16 ICEI | Instruction Cache Error Injection Enable 0 Cache Error Injection is disabled 1 When ICEDT=00, parity errors will be purposefully injected into every byte subsequently written into the cache. The parity bit of each 8-bit data element written will be inverted on cache linefills. When ICEDT=01, a double-bit error will be injected into each doubleword written into the cache by inverting the two uppermost parity check bits (p_chk[0:1]). ICEI will cause injection of errors regardless of the setting of ICECE, although reporting of errors will be masked when ICECE=0. |
| 17 | Reserved ¹ |
| 18–19 ICEDT | Instruction Cache Error Detection Type 00 Parity Error Detection is selected for both the tag and data arrays Reserved (defaults to ICEDT=01(EDC) actions) 01 EDC Error Detection is selected 1x Reserved |
| 20 | Reserved ¹ |
| 21 ICUL | Instruction Cache Unable to Lock Indicates a lock set instruction was not effective in locking a cache line. This bit is set by hardware on an “unable to lock” condition (other than lock overflows), and will remain set until cleared by software writing 0 to this bit location. |
| 22 ICLO | Instruction Cache Lock Overflow Indicates a lock overflow (overlocking) condition occurred. This bit is set by hardware on an “overlocking” condition, and will remain set until cleared by software writing 0 to this bit location. |
| 23 ICLFC | Instruction Cache Lock Bits Flash Clear When written to a ‘1’, a cache lock bits flash clear operation is initiated by hardware. Once complete, this bit is reset to ‘0’. Writing a ‘1’ while a flash clear operation is in progress will result in an undefined operation. Writing a ‘0’ to this bit while a flash clear operation is in progress will be ignored. Cache Lock Bits Flash Clear operations require approximately 134 cycles to complete. Clearing occurs regardless of the enable (ICE) value. |
| 24 ICLOA | Instruction Cache Lock Overflow Allocate Set by software to allow a lock request to replace a locked line when a lock overflow situation exists. 0 Indicates a lock overflow condition will not replace an existing locked line with the requested line 1 Indicates a lock overflow condition will replace an existing locked line with the requested line |
| 25–26 ICEA | Instruction Cache Error Action 00 Error Detection causes Machine Check exception. 01 Error Detection causes Correction/Auto-invalidation. No machine check is generated unless a locked line is invalidated. Correction is performed for single-bit tag and lock errors, and lines with multi-bit tag or lock errors are invalidated. In parity mode, tag or lock errors will result in invalidation of lines. Correction is performed for single or multi-bit data errors by reloading of the line. 1x Reserved |
| 27–28 | Reserved ¹ |

Table 13-2. L1CSR1 Field Descriptions (continued)

| Field | Description |
|-------------|---|
| 29 ICABT | Instruction Cache Operation Aborted Indicates a Cache Invalidate or a Cache Lock Bits Flash Clear operation was aborted prior to completion. This bit is set by hardware on an aborted condition, and will remain set until cleared by software writing 0 to this bit location. |
| 30 ICINV | Instruction Cache Invalidate 0 No cache invalidate 1 Cache invalidation operation When written to a '1', a cache invalidation operation is initiated by hardware. Once complete, this bit is reset to '0'. Writing a '1' while an invalidation operation is in progress will result in an undefined operation. Writing a '0' to this bit while an invalidation operation is in progress will be ignored. Cache invalidation operations require approximately 134 cycles to complete. Invalidation occurs regardless of the enable (ICE) value. During cache invalidations, the parity check bits are written with a value dependent on the ICEDT selection. ICEDT should be written with the desired value for subsequent cache operation when ICINV is set to '1' for proper operation of the cache. |
| 31 ICE | Instruction Cache Enable 0 Cache is disabled 1 Cache is enabled When disabled, cache lookups are not performed for instruction accesses. Other L1CSR1 cache control operations are still available and are not affected by ICE. |

¹ These bits are not implemented and should be written with zero for future compatibility.

13.3.2.3 L1FINV0

This register is used to flush/invalidate cache sets/ways in the data cache. The SPR number for L1FINV0 is 1016 in decimal. The L1FINV0 register is shown below.

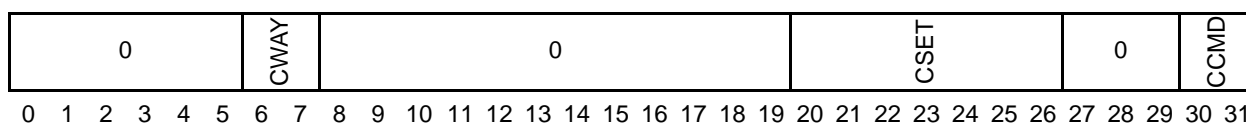

SPR - 1016; Read/Write; Reset - 0x0

Figure 13-3. L1 Flush/Invalidate Register 0 (L1FINV0)

Table 13-3. L1FINV0 Field Descriptions

| Field | Description |
|---------------|--|
| 0–5 | Reserved ¹ for way extension |
| 6–7 CWAY | Cache Way Specifies the data cache way to be selected |
| 8–19 | Reserved ¹ for set extension |
| 20–26 CSET | Cache Set Specifies the cache set to be selected |

Table 13-3. L1FINV0 Field Descriptions (continued)

| Field | Description |
|---------------|--|
| 27–29 | Reserved ¹ for set/command extension |
| 30–31 CCMD | Cache Command 00 The data contained in this entry is invalidated without flushing 01 The data contained in this entry is flushed if dirty and valid without invalidation 10 The data contained in this entry is flushed if dirty and valid and then is invalidated 11 Reset way replacement pointer to the way indicated by CWAY |

¹ These bits are not implemented and should be written with zero for future compatibility.

13.3.2.4 L1FINV1

This register is used to flush/invalidate cache sets/ways in the instruction cache. The SPR number for L1FINV1 is 959 in decimal. The L1FINV1 register is shown below.

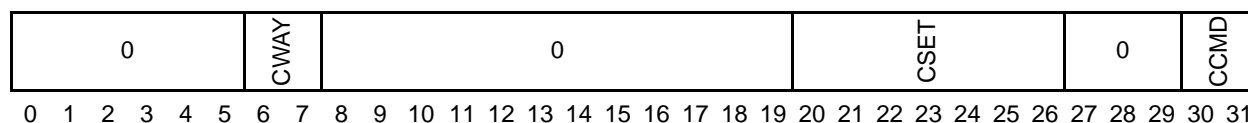

SPR - 959; Read/Write; Reset - 0x0

Figure 13-4. L1 Flush/Invalidate Register 1 (L1FINV1)
Table 13-4. L1FINV1 Field Descriptions

| Field | Description |
|---------------|--|
| 0–5 | Reserved ¹ |
| 6–7 CWAY | Cache Way Specifies the instruction cache way to be selected |
| 8–19 | Reserved ¹ |
| 20–26 CSET | Cache Set Specifies the instruction cache set to be selected |
| 27–29 | Reserved ¹ f |
| 30–31 CCMD | Cache Command 00 The data contained in this entry is invalidated 01 Reserved 10 Reserved 11 Reset way replacement pointer to the way indicated by CWAY |

¹ These bits are not implemented and should be written with zero for future compatibility.

13.4 MMU

This section lists the most commonly used registers, instructions, and features of MMU. For a complete listing of all registers and features refer to *z759n3 Core Reference Manual*.

13.4.1 Overview

The PXR40 Memory Management Unit is a 32-bit PowerPC Book E compliant implementation, with the following feature set:

- Translates from 32-bit effective to 32-bit real addresses
- 64-entry fully associative TLB with support for twenty-three page sizes (1K, 2K, 4K, 8K, 16K, 32K, 64K, 128K, 256K, 512K, 1M, 2M, 4M, 8M, 16M, 32M, 64M, 128M, 256M, 512M, 1G, 2G, 4G)
- Hardware assist for TLB miss exceptions
- Software managed by **tlbre**, **tlbwe**, **tlbsx**, **tlbsync**, and **tlbivax** instructions

13.4.2 MMU Instructions

13.4.3 TLB Read Entry Instruction (**tlbre**)

The TLB read entry instruction causes the content of a single TLB entry to be placed in the MMU assist registers. The entry is specified by the TLBSEL and ESEL fields of the MAS0 register. The entry contents are placed in the MAS1, MAS2, and MAS3 registers.

tlbre

tlbre

tlb read entry

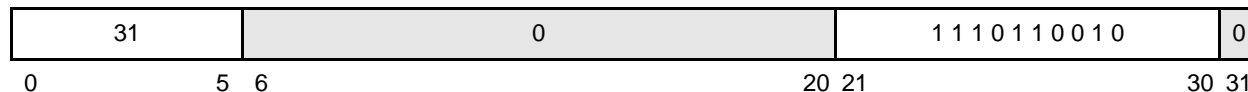

```

tlb_entry_id = MAS0(TLBSEL, ESEL)
result = MMU(tlb_entry_id)
MAS1, MAS2, MAS3 = result
    
```

13.4.4 TLB Write Entry Instruction (tlbwe)

The TLB write entry instruction causes the contents of certain fields within the MMU assist registers MAS1, MAS2, and MAS3 to be written into a single TLB entry in the MMU. The entry written is specified by the TLBSEL, and ESEL fields of the MAS0 register.

tlbwe

tlbwe

tlb write entry

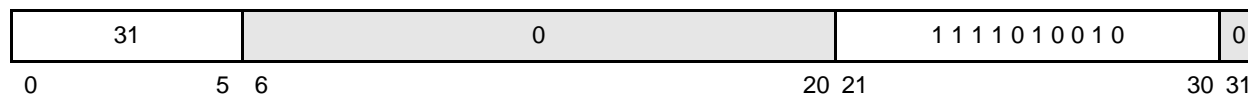

```
tlb_entry_id = MAS0(TLBSEL, ESEL)
MMU(tlb_entry_id) = MAS1, MAS2, MAS3
```

13.4.5 MMU Registers

13.4.5.1 DEAR Register

The Data Exception Address register is loaded with the effective address of the data access which results in an Alignment, Data TLB Miss, or DSI exception.

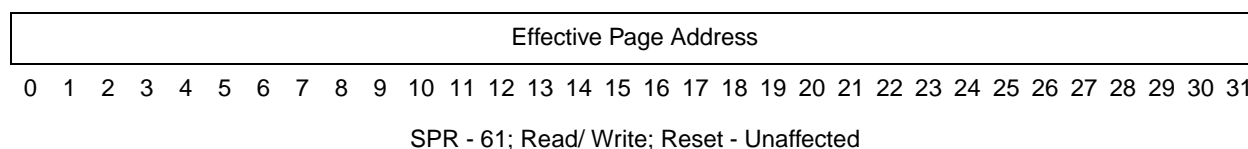

Figure 13-5. DEAR

The DEAR register can be read or written using the **mf spr** and **mt spr** instructions.

13.4.5.2 MMU Control and Status Register 0 (MMUCSR0)

The MMU Control and Status Register 0 (MMUCSR0) is a 32-bit register. The SPR number for MMUCSR0 is 1012 in decimal. MMUCSR0 controls the state of the MMU. The MMUCSR0 register is shown below.

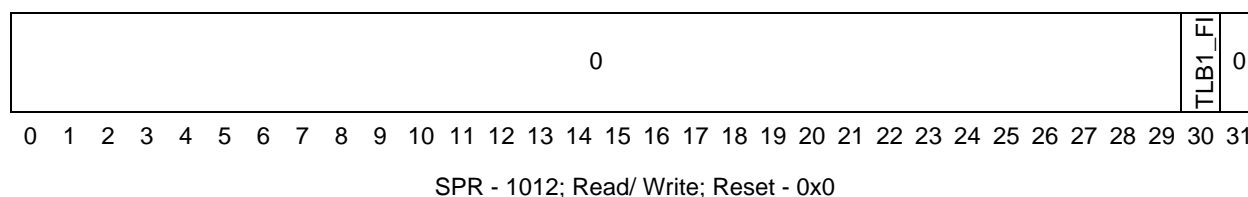

Figure 13-6. MMU Control and Status Register 0 (MMUCSR0)

The MMUCSR0 bits are described below.

Table 13-5. MMUCSR0 - MMU Control and Status Register 0

| Field | Description |
|---------------|---|
| 0–29 | Reserved ¹ |
| 30 TLB1_FI | TLB1 flash invalidate 0 - No flash invalidate 1 - TLB1 invalidation operation When written to a '1', a TLB1 invalidation operation is initiated by hardware. Once complete, this bit is reset to '0'. Writing a '1' while an invalidation operation is in progress will result in an undefined operation. Writing a '0' to this bit while an invalidation operation is in progress will be ignored. TLB1 invalidation operations require 3 cycles to complete. |
| 31 | Reserved ¹ |

¹ These bits are not implemented, will be read as zero, and writes are ignored.

13.4.5.3 MMU Assist Registers (MAS)

The PXR40 uses special purpose registers (MAS0, MAS1, MAS2, MAS3, MAS4 and MAS6) to facilitate reading and writing the TLBs. The MAS registers can be read or written using the **mfspr** and **mtspr** instructions.

The MAS0 register is shown below.

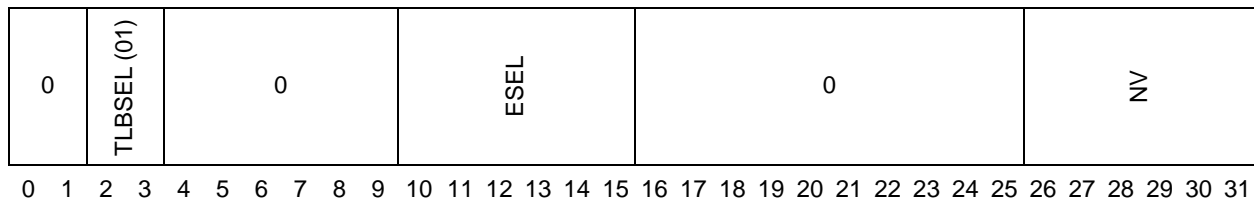

SPR - 624; Read/ Write; Reset - Unaffected

Figure 13-7. MMU Assist Register 0 (MAS0)

Fields are defined below.

Table 13-6. MAS0 —MMU Read/Write and Replacement Control

| Field | Comments, or Function when Set |
|---------------|--|
| 0–1 | Reserved ¹ |
| 2–3 | Reserved, should be written to 01 for future compatibility |
| 4–9 | Reserved ¹ |
| 10–15 ESEL | Entry select for TLB. |
| 16–25 | Reserved ¹ |
| 26–31 NV | Next replacement victim for TLB1 (software managed) Software updates this field; it is copied to the ESEL field on a TLB Error |

¹ These bits are not implemented, will be read as zero, and writes are ignored.

The MAS1 register is shown below.

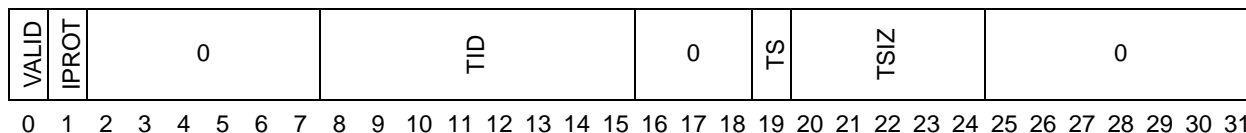

SPR - 625; Read/ Write; Reset - Unaffected

Figure 13-8. MMU Assist Register 1 (MAS1)

Fields are defined below.

Table 13-7. MAS1 —Descriptor Context and Configuration Control

| Field | Comments, or Function when Set |
|-------------|---|
| 0 VALID | TLB Entry Valid 0 This TLB entry is invalid 1 This TLB entry is valid |
| 1 IPROT | Invalidation Protect 0 Entry is not protected from invalidation 1 Entry is protected from invalidation as described in as described in the e200z759n3 reference manual's IPROT Invalidation Protection section. Protects TLB entry from invalidation by tlbivax (TLB1 only), or flash invalidates through MMUSCR0[TLB1_FI]. |
| 2–7 | Reserved ¹ |
| 8–15 TID | Translation ID bits This field is compared with the current process IDs of the effective address to be translated. A TID value of 0 defines an entry as global and matches with all process IDs. |
| 16–18 | Reserved ¹ |

Table 13-7. MAS1 —Descriptor Context and Configuration Control

| Field | Comments, or Function when Set |
|----------------|---|
| 19 TS | Translation address space This bit is compared with the IS or DS fields of the MSR (depending on the type of access) to determine if this TLB entry may be used for translation. |
| 20–24 TSIZE | Entry's page size Supported page sizes are: 0b00000 - 1KB 0b00001 - 2KB 0b00010 - 4KB 0b00011 - 8KB 0b00100 - 16KB 0b00101 - 32KB 0b00110 - 64KB 0b00111 - 128KB 0b01000 - 256KB 0b01001 - 512KB 0b01010 - 1MB 0b01011 - 2MB 0b01100 - 4MB 0b01101 - 8MB 0b01110 - 16MB 0b01111 - 32MB 0b10000 - 64MB 0b10001 - 128MB 0b10010 - 256MB 0b10011 - 512MB 0b10100 - 1GB 0b10101 - 2GB 0b10110 - 4GB All other values are undefined |
| 25–31 | Reserved ¹ |

¹ These bits are not implemented, will be read as zero, and writes are ignored.

The MAS2 register is shown below.

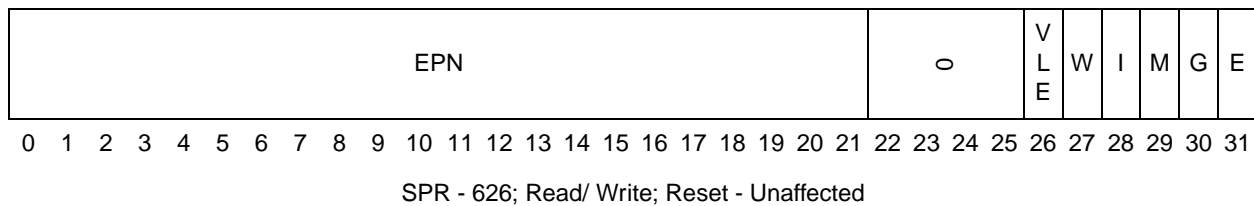

Figure 13-9. MMU Assist Register 2 (MAS2)

Fields are defined below.

Table 13-8. MAS2 - EPN and Page Attributes

| Field | Comments, or Function when Set |
|-------------|---|
| 0–21 EPN | Effective page number [0:21] |
| 22–25 | Reserved ¹ |
| 26 VLE | PowerPC VLE 0 This page is a standard BookE page 1 This page is a PowerPC VLE page |
| 27 W | Write-through Required 0 This page is considered write-back with respect to the caches in the system 1 All stores performed to this page are written through to main memory |
| 28 I | Cache Inhibited 0 This page is considered cacheable 1 This page is considered cache-inhibited |
| 29 M | Memory Coherence Required 0 Memory Coherence is not required 1 Memory Coherence is required |
| 30 G | Guarded 0 Access to this page are not guarded, and can be performed before it is known if they are required by the sequential execution model 1 All loads and stores to this page are performed without speculation (i.e. they are known to be required) PXR40 uses the guarded attribute as described in the e200z759n3 reference manual's Page Table Control Bits section. |
| 31 E | Endianness 0 The page is accessed in big-endian byte order. 1 The page is accessed in true little-endian byte order. |

¹ These bits are not implemented, will be read as zero, and writes are ignored.

The MAS3 register is shown below.

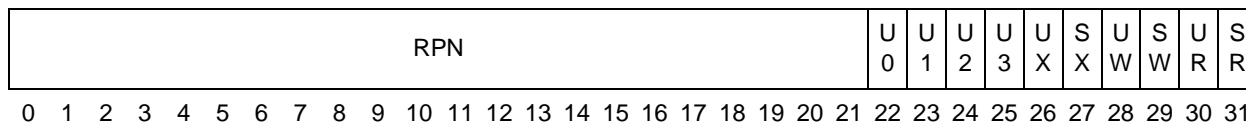

SPR - 627; Read/ Write; Reset - Unaffected

Figure 13-10. MMU Assist Register 3 (MAS3)

Table 13-9. MAS3 - RPN and Access Control

| Field | Comments, or Function when Set |
|-----------------|--|
| 0–21 RPN | Real page number [0:21] Only bits that correspond to a page number are valid. Bits that represent offsets within a page are ignored and should be zero. |
| 22–25 U0-U3 | User bits [0-3] for use by system software |
| 26–31 PERMIS | Permission bits (UX, SX, UW, SW, UR, SR) |

The MAS4 register is shown below.

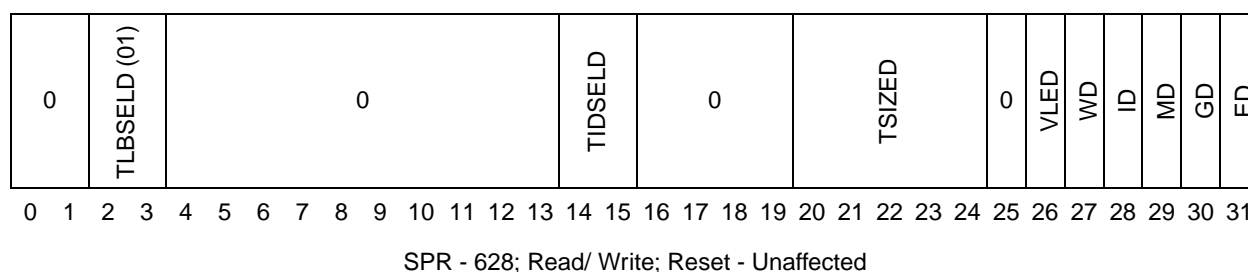
Figure 13-11. MMU Assist Register 4 (MAS4)

Fields are defined below.

Table 13-10. MAS4 - Hardware Replacement Assist Configuration Register

| Field | Comments, or Function when Set |
|------------------|--|
| 0–1 | Reserved ¹ |
| 2–3 TLBSELD | Default TLB selected 00 TLB0 01 TLB1 |
| 4–13 | Reserved ¹ |
| 14–15 TIDSELD | Default PID# to load TID from 00 PID0 01 Reserved, do not use 10 Reserved, do not use 11 TIDZ (8'h00) (Use all zeros, the globally shared value) |
| 16–19 | Reserved ¹ |
| 20–24 TSIZED | Default TSIZE value |
| 25 | Reserved ¹ |

Table 13-10. MAS4 - Hardware Replacement Assist Configuration Register

| Field | Comments, or Function when Set |
|-----------------|--------------------------------|
| 26 VLED | Default VLE value |
| 27–31 DWIMGE | Default WIMGE values |

¹ These bits are not implemented, will be read as zero, and writes are ignored.

The MAS6 register is shown below.

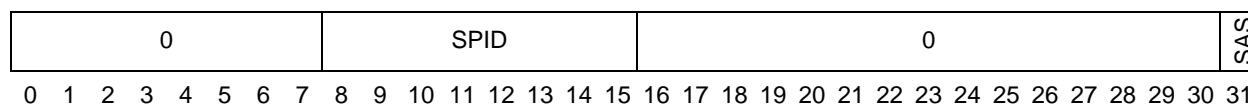

SPR - 630; Read/ Write; Reset - Unaffected

Figure 13-12. MMU Assist Register 6 (MAS6)

Fields are defined below.

Table 13-11. MAS6 - TLB Search Context Register 0

| Field | Comments, or Function when Set |
|--------------|--------------------------------|
| 0–7 | Reserved ¹ |
| 8–15 SPID | PID value for searches |
| 16–30 | Reserved ¹ |
| 31 SAS | AS value for searches |

¹ These bits are not implemented, will be read as zero, and writes are ignored.

13.5 Exceptions

This section provides an overview of core exceptions. For detailed explanation see *z759n3 Core Reference Manual*.

13.5.1 Exception Syndrome Register

The Exception Syndrome Register (ESR) provides a *syndrome* to differentiate between exceptions that can generate the same interrupt type.

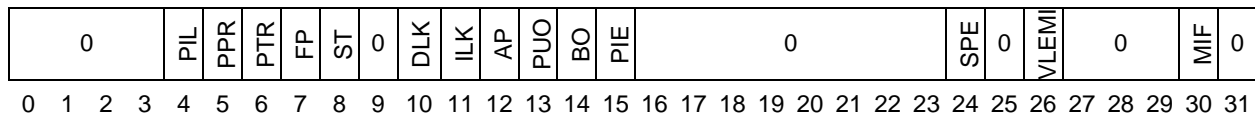

SPR - 62; Read/Write; Reset - 0x0

Figure 13-13. Exception Syndrome Register (ESR)

The ESR bits are defined below.

Table 13-12. ESR Bit Settings

| Field | Description | Associated Interrupt Type |
|-----------|---|---------------------------------------|
| 0–3 | Reserved | — |
| 4 PIL | Illegal Instruction exception | Program |
| 5 PPR | Privileged Instruction exception | Program |
| 6 PTR | Trap exception | Program |
| 7 FP | Floating-point operation | Program |
| 8 ST | Store operation | Alignment Data Storage Data TLB |
| 9 | Reserved | — |
| 10 DLK | Data Cache Locking | Data Storage |
| 11 ILK | Instruction Cache Locking | Data Storage |
| 12 AP | Reserved | — |
| 13 PUO | Unimplemented Operation exception | Program |
| 14 BO | Byte Ordering exception Mismatched Instruction Storage exception | Data Storage Instruction Storage |
| 15 PIE | Reserved | |
| 16–23 | Reserved | — |

Table 13-12. ESR Bit Settings (continued)

| Field | Description | Associated Interrupt Type |
|-------------|------------------------------|---|
| 24 SPE | SPE/EFPU APU Operation | SPE/EFPU Unavailable EFPU Floating-point Data Exception EFPU Floating-point Round Exception Alignment Data Storage Data TLB |
| 25 | Reserved | — |
| 26 VLEMI | VLE Mode Instruction | SPE/EFPU Unavailable EFPU Floating-point Data Exception EFPU Floating-point Round Exception Data Storage Data TLB Instruction Storage Alignment Program System Call |
| 27–29 | Reserved | — |
| 30 MIF | Misaligned Instruction Fetch | Instruction Storage Instruction TLB |
| 31 | Reserved | — |

13.6 Machine State Register

The Machine State Register defines the state of the processor.

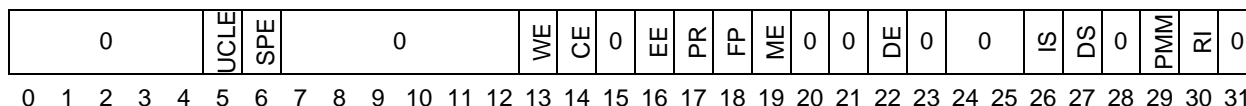

Read/ Write; Reset - 0x0

The MSR bits are defined below.

| Field | Description |
|-----------|---|
| 0–4 | Reserved ¹ |
| 5 UCLE | User Cache Lock Enable 0 - Execution of the cache locking instructions in user mode (MSR _{PR} =1) disabled; DSI exception taken instead, and ILK or DLK set in ESR. 1 - Execution of the cache lock instructions in user mode enabled. |

| Field | Description |
|----------|--|
| 6 SPE | SPE/EFPU Available 0 - Execution of SPE and EFPU APU vector instructions, and EFPU DPFP instructions is are disabled; SPE/EFPU Unavailable exception taken instead, and SPE bit is set in ESR. 1 - Execution of SPE and EFPU APU vector instructions, and EFPU DPFP instructions is are enabled. |
| 7–12 | Reserved ¹ |
| 13 WE | Wait State (Power management) enable. This bit is defined as optional in the PowerPC Book E architecture. 0 - Power management is disabled. 1 - Power management is enabled. The processor can enter a power-saving mode when additional conditions are present. The mode chosen is determined by the DOZE, NAP, and SLEEP bits in the HID0 register. |
| 14 CE | Critical Interrupt Enable 0 - Critical Input and Watchdog Timer interrupts are disabled. 1 - Critical Input and Watchdog Timer interrupts are enabled. |
| 15 | Reserved ¹ |
| 16 EE | External Interrupt Enable 0 - External Input, Decrementer, and Fixed-Interval Timer interrupts are disabled. 1 - External Input, Decrementer, and Fixed-Interval Timer interrupts are enabled. |
| 17 PR | Problem State 0 - The processor is in supervisor mode, can execute any instruction, and can access any resource (e.g. GPRs, SPRs, MSR, etc.). 1 - The processor is in user mode, cannot execute any privileged instruction, and cannot access any privileged resource. |
| 18 FP | Floating-Point Available 0 - Floating-point unit is unavailable. The processor cannot execute floating-point instructions, including floating-point loads, stores, and moves. (An FP Unavailable interrupt will be generated on attempted execution of floating point instructions). 1 - Floating-point unit is available. The processor can execute floating-point instructions. (Note that for PXR40, the floating point unit is not supported, and an Unimplemented Operation exception will be generated for attempted execution of floating-point instructions when FP is set). |
| 19 ME | Machine Check Enable 0 - Asynchronous Machine Check interrupts are disabled. 1 - Asynchronous Machine Check interrupts are enabled. |
| 20 | Reserved ¹ |
| 21 | Reserved ¹ |
| 22 DE | Debug Interrupt Enable 0 - Debug interrupts are disabled. 1 - Debug interrupts are enabled. |
| 23–25 | Reserved ¹ |
| 26 IS | Instruction Address Space 0 - The processor directs all instruction fetches to address space 0 (TS=0 in the relevant TLB entry). 1 - The processor directs all instruction fetches to address space 1 (TS=1 in the relevant TLB entry). |

| Field | Description |
|-----------|--|
| 27 DS | Data Address Space 0 - The processor directs all data storage accesses to address space 0 (TS=0 in the relevant TLB entry). 1 - The processor directs all data storage accesses to address space 1 (TS=1 in the relevant TLB entry). |
| 28 | Reserved ¹ |
| 29 PMM | PMM Performance monitor mark bit. System software can set PMM when a marked process is running to enable statistics to be gathered only during the execution of the marked process. MSR _{PR} and MSR _{PMM} together define a state that the processor (supervisor or user) and the process (marked or unmarked) may be in at any time. If this state matches an individual state specified in the Performance Monitor registers PMLC _{a n} , the state for which monitoring is enabled, counting is enabled. |
| 30 RI | Recoverable Interrupt - This bit is provided for software use to detect nested exception conditions. This bit is cleared by hardware when a Machine Check interrupt is taken |
| 31 | Reserved ¹ |

¹ These bits are not implemented, will be read as zero, and writes are ignored.

13.6.1 Machine Check Syndrome Register (MCSR)

When the processor takes a machine check interrupt, it updates the Machine Check Syndrome register (MCSR) to differentiate between machine check conditions.

| | | | | | | | | | | | | | | | | | | | | | | | | | | | | | | | |
|-----|----------|---------|----------|----------|----------|----------|----------|----------|---|-----|-----|-----|----|----|----|----|----|----|--------|-----------|-----------|-----------|----|----|----|----|----|----|----|----|----|
| MCP | IC_DPERR | CP_PERR | DC_DPERR | EXCP_ERR | IC_TPERR | DC_TPERR | IC_LKERR | DC_LKERR | 0 | NMI | MAV | MEA | 0 | IF | LD | ST | G | 0 | SNPERR | BUS_IRERR | BUS_DRERR | BUS_WRERR | 0 | | | | | | | | |
| 0 | 1 | 2 | 3 | 4 | 5 | 6 | 7 | 8 | 9 | 10 | 11 | 12 | 13 | 14 | 15 | 16 | 17 | 18 | 19 | 20 | 21 | 22 | 23 | 24 | 25 | 26 | 27 | 28 | 29 | 30 | 31 |

SPR - 572; Read/Clear; Reset - 0x0

Figure 13-14. Machine Check Syndrome Register (MCSR)

Table below describes MCSR fields. The MCSR indicates the source of a machine check condition.

All bits in the MCSR are implemented as “write ‘1’ to clear”. Software in the machine check handler is expected to clear the MCSR bits it has sampled prior to re-enabling MSR_{ME} to avoid a redundant machine check exception and to prepare for updated status bit information on the next machine check interrupt. Hardware will not clear a bit in the MCSR other than at reset.

Note that any set bit in the MCSR other than status-type bits will cause a subsequent machine check interrupt once MSR_{ME}=1.

Table 13-13. Machine Check Syndrome Register (MCSR)

| Field | Description | Exception Type ¹ | Recoverable |
|---------------|---|-----------------------------|-------------|
| 0 MCP | Machine check input pin | Async Mchk | Maybe |
| 1 IC_DPERR | Instruction Cache data array parity error | Async Mchk | Precise |
| 2 CP_PERR | Data Cache push parity error | Async Mchk | Unlikely |
| 3 DC_DPERR | Data Cache data array parity error | Async Mchk | Maybe |
| 4 EXCP_ERR | ISI, ITLB, or Bus Error on first instruction fetch for an exception handler | Async Mchk | Precise |
| 5 IC_TPERR | Instruction Cache Tag parity error | Async Mchk | Precise |
| 6 DC_TPERR | Data Cache Tag parity error | Async Mchk | Maybe |
| 7 IC_LKERR | Instruction Cache Lock error Indicates a cache control operation or invalidation operation invalidated one or more locked lines in the lcache or encountered an uncorrectable lock error, or that an lcache miss with an uncorrectable lock error occurred. May also be set on locked line refill error. | Status | — |
| 8 DC_LKERR | Data Cache Lock error Indicates a cache control operation or invalidation operation invalidated one or more locked lines in the Dcache or encountered an uncorrectable lock error, or that an lcache miss with an uncorrectable lock error occurred. May also be set on locked line refill error. | Status | — |
| 9–10 | Reserved, should be cleared. | | — |
| 11 NMI | NMI input pin | NMI | — |
| 12 MAV | MCAR Address Valid Indicates that the address contained in the MCAR was updated by hardware to correspond to the first detected Async Mchk error condition | Status | — |
| 13 MEA | MCAR holds Effective Address If MAV=1, MEA=1 indicates that the MCAR contains an effective address and MEA=0 indicates that the MCAR contains a physical address | Status | — |
| 14 | Reserved, should be cleared. | | — |
| 15 IF | Instruction Fetch Error Report An error occurred during the attempt to fetch an instruction. This could be due to a parity error, or an external bus error. MCSRR0 contains the instruction address. | Error Report | Precise |

Table 13-13. Machine Check Syndrome Register (MCSR) (continued)

| Field | Description | Exception Type ¹ | Recoverable |
|-----------------|---|-----------------------------|----------------------|
| 16 LD | Load type instruction Error Report An error occurred during the attempt to execute the load type instruction located at the address stored in MCSRR0. This could be due to a parity error or an external bus error. | Error Report | Precise |
| 17 ST | Store type instruction Error Report An error occurred during the attempt to execute the store type instruction located at the address stored in MCSRR0. This could be due to a parity error, or on certain external bus errors. | Error Report | Precise |
| 18 G | Guarded instruction Error Report An error occurred during the attempt to execute the load or store type instruction located at the address stored in MCSRR0 and the access was guarded and encountered an error on the external bus. | Error Report | Precise |
| 19–25 | Reserved, should be cleared. | | — |
| 26 SNPERR | Snoop Lookup Error An error occurred during certain snoop operations. This is typically due to a data cache tag parity error, in which case DC_TPERR will also be set. | Async Mchk | Unlikely? |
| 27 BUS_IRERR | Read bus error on Instruction fetch or linefill | Async Mchk | Precise if data used |
| 28 BUS_DRERR | Read bus error on data load or linefill | Async Mchk | Precise if data used |
| 29 BUS_WRERR | Write bus error on store or cache line push | Async Mchk | Unlikely |
| 30–31 | Reserved, should be cleared. | | — |

¹ The Exception Type indicates the exception type associated with a given syndrome bit

- “Error Report” indicates that this bit is only set for error report exceptions which cause machine check interrupts. These bits are only updated when the machine check interrupt is actually taken. Error report exceptions are not gated by MSR_{ME}. These are synchronous exceptions. These bits will remain set until cleared by software writing a “1” to the bit position(s) to be cleared.
- “Status” indicates that this bit is provides additional status information regarding the logging of a machine check exception. These bits will remain set until cleared by software writing a “1” to the bit position(s) to be cleared.
- “NMI” indicates that this bit is only set for the non-maskable interrupt type exception which causes a machine check interrupt. This bit is only updated when the machine check interrupt is actually taken. NMI exceptions are not gated by MSR_{ME}. This is an asynchronous exception. This bit will remain set until cleared by software writing a “1” to the bit position.
- “Async Mchk” indicates that this bit is set for an asynchronous machine check exception. These bits are set immediately upon detection of the error. Once any “Async Mchk” bit is set in the MCSR, a machine check interrupt will occur if MSR_{ME}=1. If MSR_{ME}=0, the machine check exception will remain pending. These bits will remain set until cleared by software writing a “1” to the bit position(s) to be cleared.

13.7 Interrupt Vector Prefix Registers (IVPR)

The Interrupt Vector Prefix Register is used during interrupt processing for determining the starting address of a software handler used to handle an interrupt. The value contained in the Vector Offset field of the IVOR selected for a particular interrupt type is concatenated with the value held in the Interrupt Vector Prefix register (IVPR) to form an instruction address from which execution is to begin. The format of IVPR is shown below.

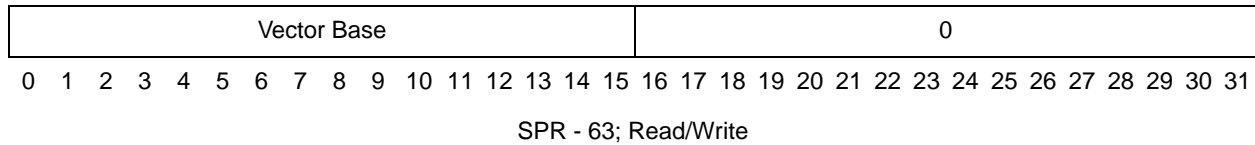

Figure 13-15. PXR40 Interrupt Vector Prefix Register (IVPR)

The IVPR fields are defined in [Table 13-14](#).

Table 13-14. IVPR Register Fields

| Field | Description |
|------------------|--|
| 0–15 Vec Base | Vector Base This field is used to define the base location of the vector table, aligned to a 64Kbyte boundary. This field provides the high-order 16 bits of the location of all interrupt handlers. The contents of the IVORxx register appropriate for the type of exception being processed are concatenated with the IVPR Vector Base to form the address of the handler in memory. |
| 16–31 | Reserved |

13.8 Interrupt Vector Offset Registers (IVORxx)

The Interrupt Vector Offset Registers are used during interrupt processing for determining the starting address of a software handler used to handle an interrupt. The value contained in the Vector Offset field of the IVOR selected for a particular interrupt type is concatenated with the value held in the Interrupt Vector Prefix register (IVPR) to form an instruction address from which execution is to begin. The format of a PXR40 IVOR is shown below.

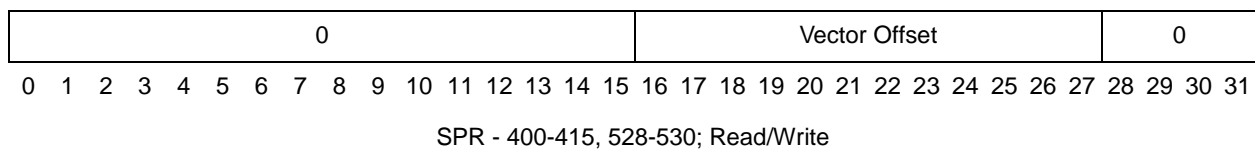

Figure 13-16. PXR40 Interrupt Vector Offset Register (IVOR)

The IVOR fields are defined in [Table 13-15](#).

Table 13-15. IVOR Register Fields

| Field | Description |
|------------------------|--|
| 0–15 | Reserved |
| 16–27 Vector Offset | Vector Offset This field is used to provide a quadword index from the base address provided by the IVPR to locate an interrupt handler. |
| 28–31 | Reserved |

13.9 Interrupt Definitions

13.9.1 Critical Input Interrupt (IVOR0)

A Critical Input exception is signalled to the processor by the assertion of the critical interrupt pin. When the core detects the exception, if the exception is enabled by MSR_{CE} , the core takes the Critical Input interrupt. The critical input is a level-sensitive signal expected to remain asserted until the core acknowledges the interrupt. If critical input is negated early, recognition of the interrupt request is not guaranteed. After the core begins execution of the critical interrupt handler, the system can safely negate critical input.

Table below lists register settings when a Critical Input interrupt is taken.

Table 13-16. Critical Input Interrupt—Register Settings

| Register | Setting Description | | |
|----------|--|--|--|
| CSRR0 | Set to the effective address of the instruction that the processor would have attempted to execute next if no exception conditions were present. | | |
| CSRR1 | Set to the contents of the MSR at the time of the interrupt | | |
| MSR | UCLE 0 SPE 0 WE 0 CE 0 EE 0 PR 0 | FP 0 ME — FE0 0 DE —/0 ¹ | FE1 0 IS 0 DS 0 PMM 0 RI — |
| ESR | Unchanged | | |
| MCSR | Unchanged | | |
| DEAR | Unchanged | | |
| Vector | IVPR _{0:15} IVOR0 _{16:27} 4b0000 (autovectored) IVPR _{0:15} p_voffset[0:11] 4b0000 (non-autovectored) | | |

¹ DE is cleared when the Debug APU is disabled. Clearing of DE is optionally supported by control in HID0 when the Debug APU is enabled.

13.9.2 Machine Check Interrupt (IVOR1)

The Machine Check APU defines a separate set of save/restore registers (MCSRR0/1), a Machine Check Syndrome register (MCSR) to record the source(s) of machine checks, and a Machine Check Address register (MCAR) to hold an address associated with a machine check for certain classes of machine checks. Return from Machine Check instructions (`rfmci`, `se_rfmci`) are also provided to support returns using MCSRR0/1.

The MSR_{RI} status bit is provided for software use in determining if multiple nested machine check exceptions have occurred. Software may interrogate the $MCSRR1_{RI}$ bit to determine if a machine check occurred during the initial portion of a machine check handler prior to handler code which sets MSR_{RI} to '1' to indicate that the handler can now tolerate another machine check condition without losing state necessary for recovery.

13.9.2.1 Machine Check Causes

Machine check causes are divided into different types:

- Error Report Machine Check conditions
- Non-Maskable Interrupt (NMI) machine check exceptions
- Asynchronous machine check exceptions

13.9.2.2 Machine Check Interrupt Actions

Machine Check interrupts for “error report” conditions and NMI are enabled and taken regardless of the state of MSR_{ME} . Machine check interrupts due to an “async mchk” syndrome bit being set in MCSR are only taken when $MSR_{ME} = 1$. When a Machine Check interrupt is taken, registers are updated as shown below.

Table 13-17. Machine Check Interrupt - Register Settings

| Register | Setting Description | | |
|----------|--|--|--|
| MCSRR0 | On a best-effort basis, the core sets this to the address of some instruction that was executing or about to be executing when the machine check condition occurred. | | |
| MCSRR1 | Set to the contents of the MSR at the time of the interrupt | | |
| MSR | UCLE 0 SPE 0 WE 0 CE 0 EE 0 PR 0 | FP 0 ME 0 FE0 0 DE 0/— ¹ | FE1 0 IS 0 DS 0 PMM 0 RI 0 |
| ESR | Unchanged | | |
| MCSR | Updated to reflect the source(s) of a machine check. Hardware only sets appropriate bits, no previously set bits are cleared by hardware. | | |
| MCAR | See | | |
| Vector | IVPR _{0:15} IVOR1 _{16:27} 4b0000 | | |

¹ DE is cleared when the Debug APU is disabled. Clearing of DE is optionally supported by control in HID0 when the Debug APU is enabled.

The Machine Check Syndrome register is provided to identify the source(s) of a machine check, and in conjunction with MCSRR1_{RI}, may be used to identify recoverable events.

13.9.3 Data Storage Interrupt (IVOR2)

A Data Storage interrupt (DSI) may occur if no higher priority exception exists and one of the following exception conditions exists:

- Read or Write Access Control exception condition
- Byte Ordering exception condition
- Cache Locking exception condition

Table below lists register settings when a DSI is taken.

Table 13-18. Data Storage Interrupt—Register Settings

| Register | Setting Description | | |
|----------|---|--|--|
| SRR0 | Set to the effective address of the excepting load/store instruction. | | |
| SRR1 | Set to the contents of the MSR at the time of the interrupt | | |
| MSR | UCLC 0 SPE 0 WE 0 CE — EE 0 PR 0 | FP 0 ME — FE0 0 DE — | FE1 0 IS 0 DS 0 PMM 0 RI — |
| ESR | Access: Byte ordering: Cache locking: | [ST], [SPE], [VLEMI]. All other bits cleared. [ST], [SPE], [VLEMI], BO. All other bits cleared. (DLK, ILK), [VLEMI], [ST]. All other bits cleared. | |
| MCSR | Unchanged | | |
| DEAR | For Access and Byte ordering exceptions, set to the effective address of a byte within the page whose access caused the violation. Undefined on Cache locking exceptions (DEAR is not updated on a cache locking exception) | | |
| Vector | IVPR _{0:15} IVOR2 _{16:27} 4b0000 | | |

13.9.4 Instruction Storage Interrupt (IVOR3)

An Instruction Storage interrupt (ISI) occurs when no higher priority exception exists and an Execute Access Control exception occurs.

Table 13-19. ISI Exceptions and Conditions

| Interrupt Type | Interrupt Vector Offset Register | Causing Conditions |
|---------------------|----------------------------------|--|
| Instruction Storage | IVOR 3 | 1. Access control. 2. Byte ordering due to misaligned instruction across page boundary to pages with mismatched VLE bits, or access to page with VLE set, and E indicating little-endian. 3. Misaligned Instruction fetch due to a change of flow to an odd halfword instruction boundary on a BookE (non-VLE) instruction page. |

Table below lists register settings when an ISI is taken.

Table 13-20. Instruction Storage Interrupt—Register Settings

| Register | Setting Description | | |
|----------|---|-------------------------------|--|
| SRR0 | Set to the effective address of the excepting instruction. | | |
| SRR1 | Set to the contents of the MSR at the time of the interrupt | | |
| MSR | UCLE 0 SPE 0 WE 0 CE — EE 0 PR 0 | FP 0 ME — FE0 0 DE — | FE1 0 IS 0 DS 0 PMM 0 RI — |
| ESR | [BO, MIF, VLEMI]. All other bits cleared. | | |
| MCSR | Unchanged | | |
| DEAR | Unchanged | | |
| Vector | IVPR _{0:15} IVOR3 _{16:27} 4b0000 | | |

13.9.5 External Input Interrupt (IVOR4)

An External Input exception is signalled to the processor by the assertion an interrupt from the interrupt controller. The input is a level-sensitive signal expected to remain asserted until core acknowledges the external interrupt. If input is negated early, recognition of the interrupt request is not guaranteed. When the core detects the exception, if the exception is enabled by MSR_{EE}, it takes the External Input interrupt.

Table below lists register settings when an External Input interrupt is taken.

Table 13-21. External Input Interrupt—Register Settings

| Register | Setting Description | | |
|----------|--|-------------------------------|--|
| SRR0 | Set to the effective address of the instruction that the processor would have attempted to execute next if no exception conditions were present. | | |
| SRR1 | Set to the contents of the MSR at the time of the interrupt | | |
| MSR | UCLE 0 SPE 0 WE 0 CE — EE 0 PR 0 | FP 0 ME — FE0 0 DE — | FE1 0 IS 0 DS 0 PMM 0 RI — |
| ESR | Unchanged | | |
| MCSR | Unchanged | | |
| DEAR | Unchanged | | |
| Vector | IVPR _{0:15} IVOR4 _{16:27} 4b0000 IVPR _{0:15} p_voffset[0:11] 4b0000 (non-autovectored) | | |

IVOR4 is the vector offset register used by autovectored External Input interrupts to determine the interrupt handler location. The PXR40 also provides the capability to directly vector External Input interrupts to multiple handlers by allowing a External Input interrupt request to be accompanied by a vector offset.

13.9.6 Alignment Interrupt (IVOR5)

An Alignment exception is generated when any of the following occurs:

- The operand of **lmw** or **stmw** not word aligned.
- The operand of **lwarx** or **stwcx.** not word aligned.
- The operand of **lharx** or **sthcx.** not halfword aligned.
- Execution of a **dcbz** instruction is attempted with a disabled cache.
- Execution of a **dcbz** instruction with an enabled cache and W or I=1.
- Execution of a SPE APU load or store instruction which is not properly aligned.

Table below lists register settings when an alignment interrupt is taken.

Table 13-22. Alignment Interrupt—Register Settings

| Register | Setting Description | | |
|----------|--|-------------------------------|--|
| SRR0 | Set to the effective address of the excepting load/store instruction. | | |
| SRR1 | Set to the contents of the MSR at the time of the interrupt | | |
| MSR | UCLE 0 SPE 0 WE 0 CE — EE 0 PR 0 | FP 0 ME — FE0 0 DE — | FE1 0 IS 0 DS 0 PMM 0 RI — |
| ESR | [ST], [SPE], [VLEMI]. All other bits cleared. | | |
| MCSR | Unchanged | | |
| DEAR | Set to the effective address of a byte of the load or store whose access caused the violation. | | |
| Vector | IVPR _{0:15} IVOR5 _{16:27} 4b0000 | | |

13.9.7 Program Interrupt (IVOR6)

A program interrupt occurs when no higher priority exception exists and one or more of the following exception conditions occur:

- Illegal Instruction exception
- Privileged Instruction exception
- Trap exception
- Unimplemented Operation exception

The PXR40 will invoke an Illegal Instruction program exception on attempted execution of the following instructions:

- Unimplemented instructions
- Instruction from the illegal instruction class
- **mtspr** and **mfspr** instructions with an undefined SPR specified
- **mtdcr** and **mfdcr** instructions with an undefined DCR specified

The PXR40 will invoke a Privileged Instruction program exception on attempted execution of the following instructions when $MSR_{PR}=1$ (user mode):

- A privileged instruction
- **mtspr** and **mfspr** instructions which specify a SPRN value with $SPRN_5=1$ (even if the SPR is undefined).

The PXR40 will invoke a Trap exception on execution of the **tw** and **twi** instructions if the trap conditions are met and the exception is not also enabled as a Debug interrupt.

Table below lists register settings when a Program interrupt is taken.

Table 13-23. Program Interrupt—Register Settings

| Register | Setting Description | | |
|----------|---|--|--|
| SRR0 | Set to the effective address of the excepting instruction. | | |
| SRR1 | Set to the contents of the MSR at the time of the interrupt | | |
| MSR | UCLE 0 SPE 0 WE 0 CE — EE 0 PR 0 | FP 0 ME — FE0 0 DE — | FE1 0 IS 0 DS 0 PMM 0 RI — |
| ESR | Illegal: Privileged: Trap: Unimplemented: | PIL, [VLEMI]. All other bits cleared. PPR, [VLEMI]. All other bits cleared. PTR, [VLEMI]. All other bits cleared. PUO, [FP], [VLEMI]. All other bits cleared. | |
| MCSR | Unchanged | | |
| DEAR | Unchanged | | |
| Vector | IVPR _{0:15} IVOR _{6:27} 4b0000 | | |

13.9.8 Floating-Point Unavailable Interrupt (IVOR7)

The Floating-point Unavailable exception is not used by the PXR40.

13.9.9 System Call Interrupt (IVOR8)

A System Call interrupt occurs when a System Call (**sc**, **se_sc**) instruction is executed and no higher priority exception exists.

Table below lists register settings when a System Call interrupt is taken.

Table 13-24. System Call Interrupt—Register Settings

| Register | Setting Description | | |
|----------|---|-------------------------------|--|
| SRR0 | Set to the effective address of the instruction <i>following</i> the sc instruction. | | |
| SRR1 | Set to the contents of the MSR at the time of the interrupt | | |
| MSR | UCLE 0 SPE 0 WE 0 CE — EE 0 PR 0 | FP 0 ME — FE0 0 DE — | FE1 0 IS 0 DS 0 PMM 0 RI — |
| ESR | [VLEMI] All other bits cleared. | | |
| MCSR | Unchanged | | |

Table 13-24. System Call Interrupt—Register Settings (continued)

| | |
|--------|--|
| DEAR | Unchanged |
| Vector | IVPR _{0:15} IVOR8 _{16:27} 4b0000 |

13.9.10 Auxiliary Processor Unavailable Interrupt (IVOR9)

The PXR40 does not utilize this interrupt.

13.9.11 Decrementer Interrupt (IVOR10)

A Decrementer interrupt occurs when no higher priority exception exists, a Decrementer exception condition exists ($TSR_{DIS}=1$), and the interrupt is enabled (both TCR_{DIE} and $MSR_{EE}=1$).

The Timer Status Register (TSR) holds the Decrementer interrupt bit set by the Timer facility when an exception is detected. Software must clear this bit in the interrupt handler to avoid repeated Decrementer interrupts.

Table below lists register settings when a Decrementer interrupt is taken.

Table 13-25. Decrementer Interrupt—Register Settings

| Register | Setting Description | | |
|----------|--|-------------------------------|--|
| SRR0 | Set to the effective address of the instruction that the processor would have attempted to execute next if no exception conditions were present. | | |
| SRR1 | Set to the contents of the MSR at the time of the interrupt | | |
| MSR | UCLE 0 SPE 0 WE 0 CE — EE 0 PR 0 | FP 0 ME — FE0 0 DE — | FE1 0 IS 0 DS 0 PMM 0 RI — |
| ESR | Unchanged | | |
| MCSR | Unchanged | | |
| DEAR | Unchanged | | |
| Vector | IVPR _{0:15} IVOR10 _{16:27} 4b0000 | | |

13.9.12 Fixed-Interval Timer Interrupt (IVOR11)

The triggering of the exception is caused by selected bits in the Time Base register changing from 0 to 1.

A Fixed-Interval Timer interrupt occurs when no higher priority exception exists, a FIT exception exists ($TSR_{FIS}=1$), and the interrupt is enabled (both TCR_{FIE} and $MSR_{EE}=1$).

The Timer Status Register (TSR) holds the FIT interrupt bit set by the Timer facility when an exception is detected. Software must clear this bit in the interrupt handler to avoid repeated FIT interrupts.

Table below lists register settings when a FIT interrupt is taken.

Table 13-26. Fixed-Interval Timer Interrupt—Register Settings

| Register | Setting Description | | |
|----------|--|-------------------------------|--|
| SRR0 | Set to the effective address of the instruction that the processor would have attempted to execute next if no exception conditions were present. | | |
| SRR1 | Set to the contents of the MSR at the time of the interrupt | | |
| MSR | UCLE 0 SPE 0 WE 0 CE — EE 0 PR 0 | FP 0 ME — FE0 0 DE — | FE1 0 IS 0 DS 0 PMM 0 RI — |
| ESR | Unchanged | | |
| MCSR | Unchanged | | |
| DEAR | Unchanged | | |
| Vector | IVPR _{0:15} IVOR11 _{16:27} 4b0000 | | |

13.9.13 Watchdog Timer Interrupt (IVOR12)

The triggering of the exception is caused by the first enabled watchdog time-out.

A Watchdog Timer interrupt occurs when no higher priority exception exists, a Watchdog Timer exception exists (TSR_{WIS}=1), and the interrupt is enabled (both TCR_{WIE} and MSR_{CE}=1).

The Timer Status Register (TSR) holds the Watchdog interrupt bit set by the Timer facility when an exception is detected. Software must clear this bit in the interrupt handler to avoid repeated Watchdog interrupts.

Table below lists register settings when a Watchdog Timer interrupt is taken.

Table 13-27. Watchdog Timer Interrupt—Register Settings

| Register | Setting Description | | |
|----------|--|--|--|
| CSRR0 | Set to the effective address of the instruction that the processor would have attempted to execute next if no exception conditions were present. | | |
| CSRR1 | Set to the contents of the MSR at the time of the interrupt | | |
| MSR | UCLE 0 SPE 0 WE 0 CE 0 EE 0 PR 0 | FP 0 ME — FE0 0 DE 0/— ¹ | FE1 0 IS 0 DS 0 PMM 0 RI — |
| ESR | Unchanged | | |
| MCSR | Unchanged | | |

Table 13-27. Watchdog Timer Interrupt—Register Settings

| | |
|--------|---|
| DEAR | Unchanged |
| Vector | IVPR _{0:15} IVOR _{12:27} 4b0000 |

¹ DE is cleared when the Debug APU is disabled. Clearing of DE is optionally supported by control in HID0 when the Debug APU is enabled.

13.9.14 Data TLB Error Interrupt (IVOR13)

A Data TLB Error interrupt occurs when no higher priority exception exists and a Data TLB Error exception exists due to a data translation lookup miss in the TLB.

Table below lists register settings when a DTLB interrupt is taken.

Table 13-28. Data TLB Error Interrupt—Register Settings

| Register | Setting Description | | |
|----------|--|-------------------------------|--|
| SRR0 | Set to the effective address of the excepting load/store instruction. | | |
| SRR1 | Set to the contents of the MSR at the time of the interrupt | | |
| MSR | UCLE 0 SPE 0 WE 0 CE — EE 0 PR 0 | FP 0 ME — FE0 0 DE — | FE1 0 IS 0 DS 0 PMM 0 RI — |
| ESR | [ST], [SPE], [VLEMI], All other bits cleared. | | |
| MCSR | Unchanged | | |
| DEAR | Set to the effective address of a byte of the load or store whose access caused the violation. | | |
| Vector | IVPR _{0:15} IVOR _{13:27} 4b0000 | | |

13.9.15 Instruction TLB Error Interrupt (IVOR14)

A Instruction TLB Error interrupt occurs when no higher priority exception exists and an Instruction TLB Error exception exists due to an instruction translation lookup miss in the TLB.

Exception extensions implemented in the PXR40 for PowerPC VLE involve extending the definition of the Instruction TLB Error Interrupt to include updating the ESR.

Table 13-29 below lists register settings when an ITLB interrupt is taken.

Table 13-29. Instruction TLB Error Interrupt—Register Settings

| Register | Setting Description |
|----------|---|
| SRR0 | Set to the effective address of the excepting instruction. |
| SRR1 | Set to the contents of the MSR at the time of the interrupt |

Table 13-29. Instruction TLB Error Interrupt—Register Settings (continued)

| | | | |
|--------|---|-------------------------------|--|
| MSR | UCLE 0 SPE 0 WE 0 CE — EE 0 PR 0 | FP 0 ME — FE0 0 DE — | FE1 0 IS 0 DS 0 PMM 0 RI — |
| ESR | [MIF] All other bits cleared. | | |
| MCSR | Unchanged | | |
| DEAR | Unchanged | | |
| Vector | IVPR _{0:15} IVOR ₁₄ _{16:27} 4b0000 | | |

13.9.16 Debug Interrupt (IVOR15)

There are multiple sources that can signal a Debug exception. A Debug interrupt occurs when no higher priority exception exists, a Debug exception exists in the Debug Status Register, and Debug interrupts are enabled (both DBCR₀_{IDM}=1 (internal debug mode) and MSR_{DE}=1).

Table below lists register settings when a Debug interrupt is taken.

Table 13-30. Debug Interrupt—Register Settings

| Register | Setting Description | | |
|------------------------------|--|---|--|
| CSRR0/ DSRR0 ¹ | Set to the effective address of the excepting instruction for IAC, BRT, RET, CRET, and TRAP. Set to the effective address of the next instruction to be executed <i>following</i> the excepting instruction for DAC and ICMP. For a UDE, IRPT, CIRPT, DCNT, or DEVT type exception, set to the effective address of the instruction that the processor would have attempted to execute next if no exception conditions were present. | | |
| CSRR1/ DSRR1 | Set to the contents of the MSR at the time of the interrupt | | |
| MSR | UCLE 0 SPE 0 WE 0 CE —/0 ² EE —/0 ² PR 0 | FP 0 ME — FE0 0 DE 0 | FE1 0 IS 0 DS 0 PMM 0 RI — |
| DBSR ³ | Unconditional Debug Event: Instr. Complete Debug Event: Branch Taken Debug Event: Interrupt Taken Debug Event: Critical Interrupt Taken Debug Event: Trap Instruction Debug Event: Instruction Address Compare: Data Address Compare: Return Debug Event: Critical Return Debug Event: Debug Counter Event: External Debug Event: and optionally, an Imprecise Debug Event flag | UDE ICMP BRT IRPT CIRPT TRAP {IAC1, IAC2, IAC3, IAC4} {DAC1R, DAC1W, DAC2R, DAC2W} RET CRET {DCNT1, DCNT2} {DEVT1, DEVT2} {IDE} | |
| ESR | Unchanged | | |
| MCSR | Unchanged | | |
| DEAR | Unchanged | | |
| Vector | IVPR _{0:15} IVOR _{15:27} 4b0000 | | |

¹ assumes that the Debug interrupt is precise

² conditional based on control bits in HID0

³ Note that multiple DBSR bits may be set

13.9.17 SPE/EFPU APU Unavailable Interrupt (IVOR32)

The SPE APU Unavailable exception is taken if MSR_{SPE} is cleared and execution of a SPE or EFPU APU instruction other than the scalar floating-point instructions or **brinc** is attempted. When the SPE/EFPU

APU Unavailable exception occurs, the processor suppresses execution of the instruction causing the exception. Table below lists register settings when a SPE/EFPU Unavailable interrupt is taken.

Table 13-31. SPE/EFPU Unavailable Interrupt—Register Settings

| Register | Setting Description | | |
|----------|---|-------------------------------|--|
| SRR0 | Set to the effective address of the excepting SPE/EFPU instruction. | | |
| SRR1 | Set to the contents of the MSR at the time of the interrupt | | |
| MSR | UCLE 0 SPE 0 WE 0 CE — EE 0 PR 0 | FP 0 ME — FE0 0 DE — | FE1 0 IS 0 DS 0 PMM 0 RI — |
| ESR | SPE, [VLEMI]. All other bits cleared. | | |
| MCSR | Unchanged | | |
| DEAR | Unchanged | | |
| Vector | IVPR _{0:15} IVOR _{32:16:27} 4b0000 | | |

13.9.18 Embedded Floating-point Data Interrupt (IVOR33)

The Embedded Floating-point Data interrupt is taken if no higher priority exception exists and a EFPU Floating-point Data exception is generated. When a Floating-point Data exception occurs, the processor suppresses execution of the instruction causing the exception.

Table below lists register settings when a EFPU Floating-point Data interrupt is taken.

Table 13-32. Embedded Floating-point Data Interrupt—Register Settings

| Register | Setting Description | | |
|----------|---|-------------------------------|--|
| SRR0 | Set to the effective address of the excepting EFPU instruction. | | |
| SRR1 | Set to the contents of the MSR at the time of the interrupt | | |
| MSR | UCLE 0 SPE 0 WE 0 CE — EE 0 PR 0 | FP 0 ME — FE0 0 DE — | FE1 0 IS 0 DS 0 PMM 0 RI — |
| ESR | SPE, [VLEMI]. All other bits cleared. | | |
| MCSR | Unchanged | | |
| DEAR | Unchanged | | |
| Vector | IVPR _{0:15} IVOR _{33:16:27} 4b0000 | | |

13.9.19 Embedded Floating-point Round Interrupt (IVOR34)

The Embedded Floating-point Round interrupt is taken when a EFPU floating-point instruction generates an inexact result and inexact exceptions are enabled.

Table below lists register settings when a EFPU Floating-point Round interrupt is taken.

Table 13-33. Embedded Floating-point Round Interrupt—Register Settings

| Register | Setting Description | | |
|----------|---|-------------------------------|--|
| SRR0 | Set to the effective address of the instruction following the excepting EFPU instruction. | | |
| SRR1 | Set to the contents of the MSR at the time of the interrupt | | |
| MSR | UCLE 0 SPE 0 WE 0 CE — EE 0 PR 0 | FP 0 ME — FE0 0 DE — | FE1 0 IS 0 DS 0 PMM 0 RI — |
| ESR | SPE, [VLEMI]. All other bits cleared. | | |
| MCSR | Unchanged | | |
| DEAR | Unchanged | | |
| Vector | IVPR _{0:15} IVOR34 _{16:27} 4b0000 | | |

13.9.20 Performance Monitor Interrupt (IVOR35)

The PXR40 provides a performance monitor interrupt that may be generated by an enabled condition or event. An enabled condition or event is as follows:

A PMC_x register overflow condition occurs with the following settings:

- $PMLCax_{CE} = 1$; that is, for the given counter the overflow condition is enabled.
- $PMCx_{OV} = 1$; that is, the given counter indicates an overflow.

For a performance monitor interrupt to be signaled on an enabled condition or event, $PMGC0_{PMIE}$ must be set.

Although an exception condition may occur with $MSR_{EE} = 0$, the interrupt cannot be taken until $MSR_{EE} = 1$.

Table below lists register settings when an performance monitor interrupt is taken.

Table 13-34. Performance Monitor Interrupt—Register Settings

| Register | Setting Description |
|----------|--|
| SRR0 | Set to the effective address of the next instruction to be executed. |
| SRR1 | Set to the contents of the MSR at the time of the interrupt |

Table 13-34. Performance Monitor Interrupt—Register Settings (continued)

| Register | Setting Description | | |
|----------|--|-------------------------------|--|
| MSR | UCLC 0 SPE 0 WE 0 CE — EE 0 PR 0 | FP 0 ME — FE0 0 DE — | FE1 0 IS 0 DS 0 PMM 0 RI — |
| ESR | Unchanged | | |
| MCSR | Unchanged | | |
| DEAR | Unchanged | | |
| Vector | IVPR _{0:15} IVOR _{35:16:27} 4b0000 | | |

13.10 Special Features

This section describes the WAIT instruction, VLE save/restore, and performance monitor.

13.10.1 WAIT APU

The **wait** instruction allows software to shutdown the core and wait for an asynchronous interrupt or debug interrupt to occur. The instruction can be used to cease processor activity in both user and supervisor modes. Asynchronous interrupts which will cause the waiting state to be exited if enabled are critical input, external input, machine check pin, and Non-maskable interrupts (NMI).

Executing a **wait** instruction ensures that all instructions have completed before the **wait** instruction completes, causes processor instruction fetching to cease, and ensures that no subsequent instructions are initiated until an asynchronous interrupt or a debug interrupt occurs.

Once the **wait** instruction has completed, the program counter will point to the next sequential instruction.

Wait instruction can be used in conjunction with the SIU_HALT mechanism and SIU_HLTACK registers to enter a low power state while waiting.

Software must ensure that interrupts responsible for exiting the waiting state are enabled before executing a wait instruction.

wait

Wait for Interrupt

wait

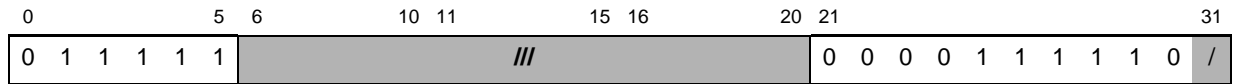

wait

13.10.2 Volatile Context Save/Restore APU

The PXR40 implements Volatile Context Save/Restore APU to support the capability to quickly save and restore volatile register context on entry into an interrupt handler. To support this functionality, a new set of instructions is defined as part of the APU.

- e_lmvgprw, e_stmvgprw - load/store multiple volatile gprs (r0, r3:r12)
- e_lmvsprw, e_stmvsprw - load/store multiple volatile sprs (CR, LR, CTR, and XER)
- e_lmvsrrw, e_stmvsrrw - load/store multiple volatile srrs (SRR0, SRR1)
- e_lmvsrww, e_stmvsrww - load/store multiple volatile csrrs (CSRR0, CSRR1)
- e_lmvsdrrw, e_stmvsdrrw - load/store multiple volatile dsrrs (DSRR0, DSRR1)
- e_lmvmcsrrw, e_stmvmcsrrw - load/store multiple volatile mcsrrs (MCSRR0, MCSRR1)

These instructions are available in VLE instruction pages to perform a multiple register load or store to a word aligned memory address.

13.10.3 Performance Monitor

The performance monitor provides the ability to count predefined events and processor clocks associated with particular operations, such as cache misses, mis-predicted branches, or the number of cycles an execution unit stalls. The count of such events can be used to trigger the performance monitor interrupt.

The performance monitor can be used to do the following:

- Improve system performance by monitoring software execution and then recoding algorithms for more efficiency. For example, memory hierarchy behavior can be monitored and analyzed to optimize task scheduling or data distribution algorithms.
- Characterize processors in environments not easily characterized by benchmarking.
- Help system developers bring up and debug their systems.

For a complete description of Performance Monitor see *z759n3 Core Reference Manual*.

Chapter 14

AMBA Crossbar Switch (XBAR)

14.1 Introduction

This chapter describes the multi-port crossbar switch (XBAR), which supports simultaneous connections between master ports and slave ports. XBAR supports a 32-bit address bus width and a 64-bit data bus width at all master and slave ports and runs at half the system frequency.

14.1.1 Overview

The XBAR allows concurrent transactions to occur from any master port to any slave port. It is possible for all master ports and slave ports to be in use at the same time as a result of independent master requests. If a slave port is simultaneously requested by more than one master port, arbitration logic selects the higher priority master and grant it ownership of the slave port. All other masters requesting that slave port are stalled until the higher priority master completes its transactions.

By default, requesting masters are granted access based on a fixed priority. A round-robin priority mode also is available. In this mode, requesting masters are treated with equal priority and are granted access to a slave port in round-robin fashion, based upon the ID of the last master to be granted access. A block diagram of the XBAR is shown in [Figure 14-1](#).

The XBAR can place a slave port in a low-power park mode to avoid dissipating any power transitional address, control or data signals when the master port is not actively accessing the slave port. There is a one-cycle arbitration overhead for exiting low-power park mode.

14.1.2 Block Diagram

Figure 14-1 shows a block diagram of the crossbar switch.

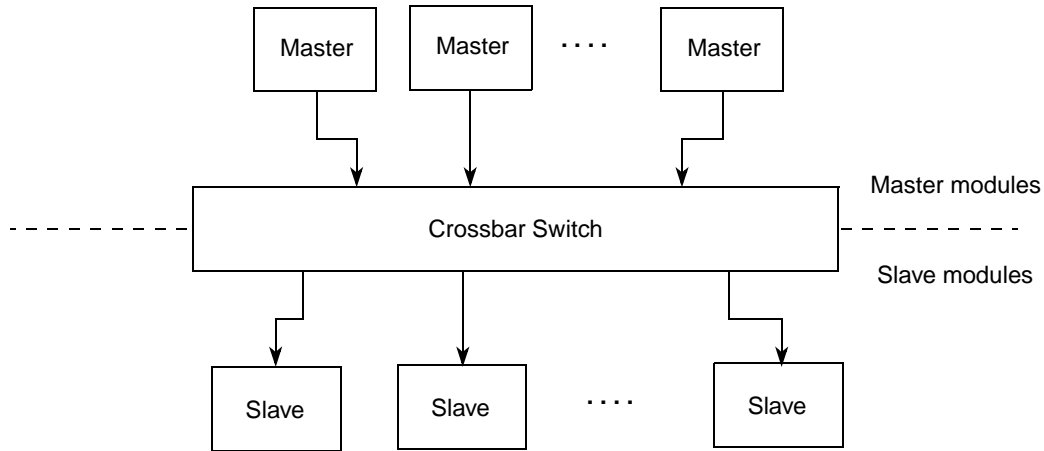

Figure 14-1. XBAR Block Diagram

Table 14-1 gives the crossbar switch port for each master and slave, and the assigned and fixed ID number for each master. The following table shows the master ID numbers as they relate to the master port numbers:

Table 14-1. XBAR Switch Ports

| Module | Port | | Master ID |
|---|--------|--------|-----------|
| | Type | Number | |
| e200z7 core0 — CPU instruction | Master | 0 | 0 |
| e200z7 core0 — Data | Master | 1 | 0 |
| Nexus 3 | | | 8 |
| eDMA_A | Master | 4 | 4 |
| eDMA_B | Master | 5 | 5 |
| FlexRay | Master | 6 | 6 |
| Reserved ¹ | Master | 7 | 3 |
| On-chip Flash (accessed by core 0 only) | Slave | 0 | — |
| EBI (development bus) | Slave | 1 | — |
| On-chip SRAM | Slave | 2 | — |
| Peripheral bridge A (PBRIDGE_A) | Slave | 6 | — |
| Peripheral bridge B (PBRIDGE_B) | Slave | 7 | — |

¹ This port is not usable by customers, but exists in the device. Therefore, the priority must be set to a unique value in the Master Priority Registers.

14.1.3 Features

- Multiple master and slave ports with programmable priorities and attributes.

- 32-bit address, 64-bit data paths
- Fully concurrent transfers between independent master and slave ports

14.1.4 Modes of Operation

14.1.4.1 Normal Mode

In normal mode, the XBAR provides the register interface and logic that controls crossbar switch configuration.

14.1.4.2 Debug Mode

The XBAR operation in debug mode is identical to operation in normal mode.

14.2 Memory Map and Register Definition

The memory map for the XBAR program-visible registers is shown in [Table 14-2](#).

Table 14-2. XBAR Register Memory Map

| Address | Register | Bits | Access | Reset Value | Section/Page |
|------------------------|---|------|--------|-------------|-------------------------------|
| Base = 0xFFFF0_4000 | XBAR_MPR0—Master priority register for slave port 0 | 32 | R/W | 0x7654_3210 | 14.2.1.1/14-4 |
| Base + (0x0004–0x000F) | Reserved | | | | |
| Base + 0x0010 | XBAR_SGPCR0—General-purpose control register for slave port 0 | 32 | R/W | 0x0000_0000 | 14.2.1.2/14-6 |
| Base + (0x0014–0x00FF) | Reserved | | | | |
| Base + 0x0100 | XBAR_MPR1—Master priority register for slave port 1 | 32 | R/W | 0x7654_3210 | 14.2.1.1/14-4 |
| Base +(0x0104–0x010F) | Reserved | | | | |
| Base + 0x0110 | XBAR_SGPCR1—General-purpose control register for slave port 1 | 32 | R/W | 0x0000_0000 | 14.2.1.2/14-6 |
| Base + (0x0114–0x01FF) | Reserved | | | | |
| Base + 0x0200 | XBAR_MPR2—Master priority register for slave port 2 | 32 | R/W | 0x7654_3210 | 14.2.1.1/14-4 |
| Base +(0x0204–0x020F) | Reserved | | | | |
| Base + 0x0210 | XBAR_SGPCR2—General-purpose control register for slave port 2 | 32 | R/W | 0x0000_0000 | 14.2.1.2/14-6 |
| Base + (0x0214–0x05FF) | Reserved | | | | |
| Base + 0x0600 | XBAR_MPR6—Master priority register for slave port 6 | 32 | R/W | 0x7654_3210 | 14.2.1.1/14-4 |
| Base + (0x0604–0x060F) | Reserved | | | | |

Table 14-2. XBAR Register Memory Map (continued)

| Address | Register | Bits | Access | Reset Value | Section/Page |
|------------------------|---|------|--------|-------------|-------------------------------|
| Base + 0x0610 | XBAR_SGPCR6—General-purpose control register for slave port 6 | 32 | R/W | 0x0000_0000 | 14.2.1.2/14-6 |
| Base + (0x0614–0x06FF) | Reserved | | | | |
| Base + 0x0700 | XBAR_MPR7—Master priority register for slave port 7 | 32 | R/W | 0x7654_3210 | 14.2.1.1/14-4 |
| Base + (0x0704–0x070F) | Reserved | | | | |
| Base + 0x0710 | XBAR_SGPCR7—General-purpose control register for slave port 7 | 32 | R/W | 0x0000_0000 | 14.2.1.2/14-6 |
| Base + (0x0714– x07FF) | Reserved | | | | |

14.2.1 Register Descriptions

There are two registers for each slave port of the XBAR. The registers can only be accessed in supervisor mode using 32-bit accesses.

The slave SGPCR also features a bit (RO), which when written with a 1, prevents all slave registers for that port from being written to again until a reset occurs. The registers remain readable, but future write attempts have no effect on the registers and are terminated with an error response.

14.2.1.1 Master Priority Registers (XBAR_MPR n)

The XBAR_MPR for a slave port sets the priority of each master port when operating in fixed priority mode. They are ignored in round-robin priority mode unless more than one master has been assigned high priority by a slave.

NOTE

Masters must be assigned unique priority levels.

The master priority register can only be accessed in supervisor mode with 32-bit accesses. After the read only (RO) bit is set in the slave general-purpose control register, the master priority register can only be read. Attempts to write to it have no effect on the MPR and result in an error.

NOTE

XBAR_MPR must be written with a read/modify/write for code compatibility.

Address: Base + 0x0000 (XBAR_MPR0)
 Base + 0x0100 (XBAR_MPR1)
 Base + 0x0200 (XBAR_MPR2)
 Base + 0x0600 (XBAR_MPR6)
 Base + 0x0700 (XBAR_MPR7)

Access: Supervisor R/W

| | | | | | | | | | | | | | | | | |
|-------|----|----|----|----|----|-------|----|----|----|-------|----|----|----|-------|----|----|
| | 0 | 1 | 2 | 3 | 4 | 5 | 6 | 7 | 8 | 9 | 10 | 11 | 12 | 13 | 14 | 15 |
| R | 0 | 1 | 0 | 1 | 0 | MSTR6 | | | 0 | MSTR5 | | | 0 | MSTR4 | | |
| W | 0 | 1 | 0 | 1 | 0 | MSTR6 | | | 0 | MSTR5 | | | 0 | MSTR4 | | |
| Reset | 0 | 1 | 0 | 1 | 0 | 1 | 0 | 0 | 0 | 0 | 1 | 1 | 0 | 0 | 1 | 0 |
| | 16 | 17 | 18 | 19 | 20 | 21 | 22 | 23 | 24 | 25 | 26 | 27 | 28 | 29 | 30 | 31 |
| R | 0 | 0 | 0 | 0 | 0 | 0 | 0 | 0 | 0 | MSTR1 | | | 0 | MSTR0 | | |
| W | 0 | 0 | 0 | 0 | 0 | 0 | 0 | 0 | 0 | MSTR1 | | | 0 | MSTR0 | | |
| Reset | 0 | 0 | 0 | 0 | 0 | 0 | 0 | 0 | 0 | 0 | 0 | 1 | 0 | 0 | 0 | 0 |

Figure 14-2. Master Priority Registers (XBAR_MPR_n)

Table 14-3. XBAR_MPR_n Descriptions

| Field | Description |
|----------------|---|
| 0–3 | Reserved, must be set to 0b0101. Undefined operation if not. |
| 4 | Reserved, must be cleared. |
| 5–7 MSTR6 | Master 6 priority. Set the arbitration priority for master port 6 on the associated slave port. 000 Master 6 has the highest priority when accessing slave port <i>n</i> . ⋮ 101 Master 6 has the lowest priority when accessing slave port <i>n</i> . 110–111 Invalid values |
| 8 | Reserved, must be cleared. |
| 9–11 MSTR5 | Master 5 priority. Set the arbitration priority for master port 5 on the associated slave port. 000 Master 5 has the highest priority when accessing slave port <i>n</i> . ⋮ 101 Master 5 has the lowest priority when accessing slave port <i>n</i> . 110–111 Invalid values |
| 12 | Reserved, must be cleared. |
| 13–15 MSTR4 | Master 4 priority. Set the arbitration priority for master port 4 on the associated slave port. 000 Master 4 has the highest priority when accessing slave port <i>n</i> . ⋮ 101 Master 4 has the lowest priority when accessing slave port <i>n</i> . 110–111 Invalid values |
| 16–24 | Reserved, must be cleared. |

Table 14-3. XBAR_MPR n Descriptions (continued)

| Field | Description |
|----------------|---|
| 25–27 MSTR1 | Master 1 priority. Set the arbitration priority for master port 1 on the associated slave port. 000 Master 1 has the highest priority when accessing slave port n . ⋮ 101 Master 1 has the lowest priority when accessing slave port n . 110–111 Invalid values |
| 28 | Reserved, must be cleared. |
| 29–31 MSTR0 | Master 0 priority. Set the arbitration priority for master port 0 on the associated slave port. 000 Master 0 has the highest priority when accessing slave port n . ⋮ 101 Master 0 has the lowest priority when accessing slave port n . 110–111 Invalid values |

14.2.1.2 Slave General-Purpose Control Registers (XBAR_SGPCR n)

The XBAR_SGPCR n of a slave port controls several features of the slave port, including the following:

- Round-robin or fixed arbitration policy for a particular slave port
- Write protection of any slave port registers
- Parking algorithm used for a slave port

The PARK field indicates which master port this slave port parks on when no active access attempts are being made to the slave and the parking control field is set to park on a specific master.

XBAR_SGPCR n [PARK] must only be programmed to select master ports that are actually available on the device, otherwise undefined behavior results. The low-power park feature can result in an overall power savings if the slave port is not saturated; however, an extra clock of latency results whenever any master tries to access a slave (not being accessed by another master) because it is not parked on any master.

The XBAR_SGPCR can only be accessed in supervisor mode with 32-bit accesses. After the RO (read only) bit is set in the XBAR_SGPCR, the XBAR_SGPCR and the SBAR_MPR can only be read. Attempts to write to them have no effect and results in an error.

NOTE

Some of the unused bits in the SGPCR n registers are writeable and readable, but they serve no function. Setting any of these bits has no effect on the operation of this module.

Address Base + 0x0010 (XBAR_SGPCR0) Access: R/W
 : Base + 0x0110 (XBAR_SGPCR1)
 Base + 0x0210 (XBAR_SGPCR2)
 Base + 0x0610 (XBAR_SGPCR6)
 Base + 0x0710 (XBAR_SGPCR7)

| | | | | | | | | | | | | | | | | |
|-------|-----------------|---|---|---|---|---|---|---|---|---|----|----|----|----|----|----|
| | 0 | 1 | 2 | 3 | 4 | 5 | 6 | 7 | 8 | 9 | 10 | 11 | 12 | 13 | 14 | 15 |
| R | RO ¹ | 0 | 0 | 0 | 0 | 0 | 0 | 0 | 0 | 0 | 0 | 0 | 0 | 0 | 0 | 0 |
| W | | | | | | | | | | | | | | | | |
| Reset | 0 | 0 | 0 | 0 | 0 | 0 | 0 | 0 | 0 | 0 | 0 | 0 | 0 | 0 | 0 | 0 |

| | | | | | | | | | | | | | | | | |
|-------|----|----|----|----|----|----|-----|----|----|----|------|----|----|------|----|----|
| | 16 | 17 | 18 | 19 | 20 | 21 | 22 | 23 | 24 | 25 | 26 | 27 | 28 | 29 | 30 | 31 |
| R | 0 | 0 | 0 | 0 | 0 | 0 | ARB | | 0 | 0 | PCTL | | 0 | PARK | | |
| W | | | | | | | | | | | | | | | | |
| Reset | 0 | 0 | 0 | 0 | 0 | 0 | 0 | 0 | 0 | 0 | 0 | 0 | 0 | 0 | 0 | 0 |

¹ After this bit is set, only a hardware reset clears it.

Figure 14-3. Slave General-Purpose Control Registers (XBAR_SGPCR_n)

Table 14-4. XBAR_SGPCR_n Field Descriptions

| Field | Description |
|---------------|---|
| 0 RO | Read only. Used to force all of a slave port's registers to be read only. After written to 1, it can only be cleared by hardware reset. 0 All this slave port's registers can be written. 1 All this slave port's registers are read only and cannot be written (attempted writes have no effect and result in an error response). |
| 1–21 | Reserved, must be cleared. |
| 22–23 ARB | Arbitration mode. Used to select the arbitration policy for the slave port. This field is initialized by hardware reset. 00 Fixed priority using MPR 01 Round-robin priority 10 Invalid value 11 Invalid value |
| 24–25 | Reserved, must be cleared. |
| 26–27 PCTL | Parking control. Used to select the parking algorithm used by the slave port. This field is initialized by hardware reset. 00 When no master is making a request, the arbiter parks the slave port on the master port defined by the PARK control field. 01 POL—Park on last. When no master is making a request, the arbiter parks the slave port on the last master to own the slave port. 10 LPP—Low-power park. When no master is making a request, the arbiter parks the slave port on no master and drives all slave port outputs to a safe state. 11 Invalid value |

Table 14-4. XBAR_SGPCR n Field Descriptions (continued)

| Field | Description |
|---------------|--|
| 28 | Reserved, must be cleared. |
| 29–31 PARK | Park. Used to determine which master port this slave port parks on when no masters are actively making requests. PCTL must be set to 0b00. 000 Park on master port 0 001 Park on master port 1 010 Invalid value 011 Invalid value 100 Park on master port 4 101 Park on master port 5 110 Park on master port 6 111 Invalid value |

14.3 Functional Description

This section describes the functionality of the XBAR in more detail.

14.3.1 Overview

The main goal of the XBAR is to increase overall system performance by allowing multiple masters to communicate concurrently with multiple slaves. To maximize data throughput, it is essential to keep arbitration delays to a minimum.

This section examines data throughput from the point of view of masters and slaves, detailing when the XBAR stalls masters, or inserts bubbles on the slave side.

14.3.2 General Operation

When a master makes an access to the XBAR from an idle master state, the access is taken immediately by the XBAR. If the targeted slave port of the access is available (that is, the requesting master is currently granted ownership of the slave port), the access is immediately presented on the slave port. It is possible to make single clock (zero wait state) accesses through the XBAR by a granted master. If the targeted slave port of the access is busy or parked on a different master port, the requesting master receives wait states until the targeted slave port can service the master request. The latency in servicing the request depends on each master's priority level and the responding slave's access time.

Because the XBAR appears to be simply another slave to the master device, the master device has no indication that it owns the slave port it is targeting. While the master does not have control of the slave port it is targeting, it is wait-stated.

A master is given control of a targeted slave port only after a previous access to a different slave port has completed, regardless of its priority on the newly targeted slave port. This prevents deadlock from occurring when a master has the following conditions:

- Outstanding request to slave port A that has a long response time
- Pending access to a different slave port B
- Lower priority master also makes a request to the different slave port B.

In this case, the lower priority master is granted bus ownership of slave port B after a cycle of arbitration, assuming the higher priority master slave port A access is not terminated.

After a master has control of the slave port it is targeting, the master remains in control of that slave port until it gives up the slave port by running an IDLE cycle, leaves that slave port for its next access, or loses control of the slave port to a higher priority master with a request to the same slave port. However, because all masters run a fixed-length burst transfer to a slave port, it retains control of the slave port until that transfer sequence is completed. In round-robin arbitration mode, the current master is forced to hand off bus ownership to an alternately requesting master at the end of its current transfer sequence.

When a slave bus is idled by the XBAR, it can be parked on the master port using the PARK bits in the XBAR_SGPCR (slave general-purpose control register), or on the last master to have control of the slave port. This can avoid the initial clock of the arbitration delay if the master must arbitrate to gain control of the slave port. The slave port can also be put into low-power park mode to save power.

14.3.3 Master Ports

The XBAR terminates an access and it is not allowed to pass through the XBAR unless the master currently is granted access to the slave port to which the access is targeted. A master access is taken if the slave port to which the access decodes is either currently servicing the master or is parked on the master. In this case, the XBAR is completely transparent and the master access is immediately transmitted on the slave bus and no arbitration delays are incurred. A master access stall if the access decodes to a slave port that is busy serving another master, parked on another master or is in low-power park mode.

If the slave port is currently parked on another master or is in low-power park mode, and no other master is requesting access to the slave port, then only one clock of arbitration is incurred. If the slave port is currently serving another master of a lower priority and the master has a higher priority than all other requesting masters, then the master gains control over the slave port as soon as the data phase of the current access is completed. If the slave port is currently servicing another master of a higher priority, then the master gains control of the slave port after the other master releases control of the slave port if no other higher priority master is also waiting for the slave port.

A master access is responded to with an error if the access decodes to a location not occupied by a slave port. This is the only time the XBAR directly responds with an error response. All other error responses received by the master are the result of error responses on the slave ports being passed through the XBAR.

14.3.4 Slave Ports

The goal of the XBAR with respect to the slave ports is to keep them 100% saturated when masters are actively making requests. To do this the XBAR must not insert any bubbles onto the slave bus unless absolutely necessary.

There is only one instance when the XBAR forces a bubble onto the slave bus when a master is actively making a request. This occurs when a handoff of bus ownership occurs and there are no wait states from the slave port. A requesting master which does not own the slave port is granted access after a one clock delay.

The only other time the XBAR has control of the slave port is when no masters are making access requests to the slave port and the XBAR is forced to either park the slave port on a specific master, or place the slave port into low-power park mode. In these cases, the XBAR forces IDLE for the transfer type.

14.3.5 Priority Assignment

Each master port must be assigned a unique 2-bit priority level in fixed priority mode. If multiple master ports are assigned the same priority level within a register (XBAR_MPR) undefined behavior results.

14.3.6 Arbitration

XBAR supports two arbitration schemes; a simple fixed-priority comparison algorithm, and a round-robin fairness algorithm. The arbitration scheme is independently programmable for each slave port.

14.3.6.1 Fixed Priority Operation

When operating in fixed-priority arbitration mode, each master is assigned a unique priority level in the XBAR_MPR. If two masters both request access to a slave port, the master with the highest priority in the selected priority register gains control over the slave port.

Any time a master makes a request to a slave port, the slave port checks to see if the new requesting master's priority level is higher than that of the master that currently has control over the slave port (if any). The slave port does an arbitration check at every clock edge to ensure that the proper master (if any) has control of the slave port.

If the new requesting master's priority level is higher than that of the master that currently has control of the slave port, the higher priority master is granted control at the termination of any currently pending access, assuming the pending transfer is not part of a burst transfer.

A new requesting master must wait until the end of the fixed-length burst transfer, before it is granted control of the slave port. But if the new requesting master's priority level is lower than that of the master that currently has control of the slave port, the new requesting master is forced to wait until the master that currently has control of the slave port is finished accessing the current slave port.

14.3.6.2 Round-Robin Priority Operation

When operating in round-robin mode, each master is assigned a relative priority based on the master port number. This relative priority is compared to the port number of the last master to perform a transfer on the slave bus. The highest priority requesting master becomes the owner of the slave bus at the next transfer boundary (accounting for fixed-length burst transfers). Priority is based on how far ahead the port number of the requesting master is to the port number of the last master.

After granted access to a slave port, a master may perform as many transfers as desired to that port until another master makes a request to the same slave port. The next master in line is granted access to the slave port when the current transfer is completed, or possibly on the next clock cycle if the current master has no pending access request.

As an example of arbitration in round-robin mode, assume the three masters have ID's 0, 1, and 2. If the last master of the slave port was master 1, and masters 0 and 2 make simultaneous requests, they are serviced in the order 2 and then 0 assuming no further requests are made.

As another example, if master 1 is waiting on a response from a slow slave and has no further pending access to that slave, no other masters are requesting, and master 0 then makes a request, master 0's request is granted on the next clock (assuming that master 1's transfer is not a burst transfer), and the request information for master 0 is driven to the slave as a pending access. If master 2 were to make a request after master 0 has been granted access, but prior to master 0's access being accepted by the slave, master 0 maintains the grant on the slave port, and master 2 is delayed until the next arbitration boundary, which occurs after the transfer is complete. The round-robin pointer is reset to 0, so if master 1 has another request that occurs before master 0's transfer completes, master 1 is the granted the bus. This implies a worst case latency of N transfers for a system with N masters.

Parking may continue to be used in round-robin mode, but affects the round-robin pointer unless the parked master actually performs a transfer. Handoff to the next master in line occurs after one cycle of arbitration.

The slave port does an arbitration check at every clock edge to ensure that the proper master (if any) has control of the slave port.

A new requesting master must wait until the end of the fixed-length burst transfer, before it is granted control of the slave port. If the new requesting master's priority level is lower than that of the master that currently has control of the slave port, the new requesting master is forced to wait until the master that currently has control of the slave port completes its access.

14.3.6.2.1 Parking

If no master is currently requesting the slave port, the slave port is parked. The slave port parks in one of three places, indicated by the value of the PCTL field in the XBAR_SGPCR.

- If park-on-specific master mode is selected, the slave port parks on the master designated by the PARK field. When the master accesses the slave port again, a one clock arbitration penalty is incurred only for an access request made by another master port to the slave port. No other arbitration penalties are incurred. All other masters pay a one clock penalty.
- If park-on-last (POL) mode is selected, then the slave port parks on the last master to access it, passing that master's signals through to the slave bus. When the master accesses the slave port again, no other arbitration penalties are incurred except that a one clock arbitration penalty is incurred for each access request to the slave port made by another master port. All other masters pay a one clock penalty.
- If the low-power-park (LPP) mode is selected, then the slave port enters low-power park mode. It is not under control by any master and does not transmit any master signals to the slave bus. All slave bus activity halts because all slave bus signals are not toggling. This saves power if the slave port is not used for some time. However, when a master does make a request to a slave port parked in low-power-park, a one clock arbitration delay is incurred to get ownership of the slave port.

Chapter 15

Peripheral Bridge (PBRIDGE)

15.1 Introduction

There are two peripheral bridges, PBRIDGE A and PBRIDGE B, that act as interfaces between the system bus and lower bandwidth peripherals. In this manual, PBRIDGE refers to either of these bridges, as their functionality is identical. The only difference is the peripherals to which they connect. Accesses that fall within the address space of the PBRIDGE are decoded to provide individual module selects for peripheral devices on the slave bus interface.

15.1.1 Block Diagram

The PBRIDGE is the interface between the system bus and on-chip peripherals as shown in [Figure 15-1](#).

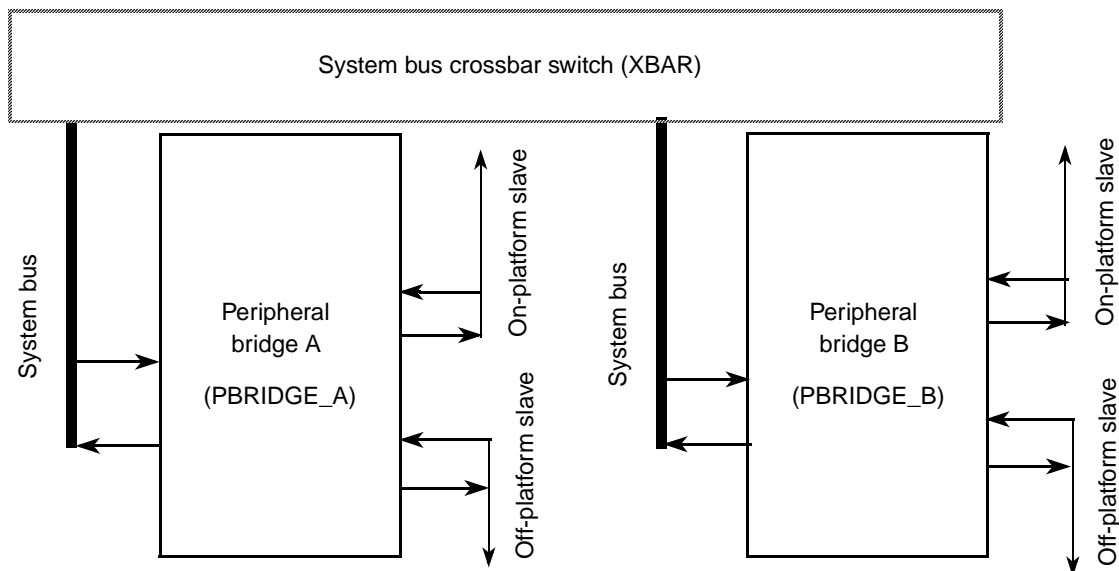

Figure 15-1. PBRIDGE Interface

15.1.2 Access Protections

The PBRIDGE provides programmable access protections for both masters and peripherals. Access protections allow the program to:

- Override the privilege level of a master to change it to user mode privilege
- Designate masters as trusted or untrusted

Peripherals can implement the following restrictions:

Peripheral Bridge (PBRIDGE)

- Require supervisor privilege level for access
- Restrict access to a trusted master only
- Write-protect the peripheral to deny updates to the peripheral (i.e., not all accesses are denied, reads are still allowed)

Refer to [Table 15-1](#) for a list of master/slave IDs and the peripherals for with each master and slave. The shaded areas in the table do not apply.

Refer to [Section 12.2.2.9, Flash Bus Interface Access Protection Register \(FLASH_BIUAPR\)](#), in the Flash chapter, for more information on access protection.

Table 15-1. Peripheral Bridge Master/Slave ID Table

| Module | Internal Master ID | XBAR Port | Peripheral |
|--------------------------------|--------------------|-----------|------------------|
| e200z7 core—CPU instruction | 0 | Master 0 | — |
| e200z7—Data | 0 | Master 1 | — |
| Nexus 3 | 8 | | — |
| eDMA_A | 4 | Master 4 | — |
| eDMA_B | 5 | Master 5 | — |
| FlexRay | 6 | Master 6 | — |
| On-chip Flash | — | Slave 0 | — |
| External development bus (EBI) | — | Slave 1 | — |
| On-chip SRAM | — | Slave 2 | — |
| PBRIDGE A | — | Slave 6 | PBRIDGE A |
| | — | | FMPLL |
| | — | | EBI control |
| | — | | Flash control |
| | — | | SIU |
| | — | | eMIOS |
| | — | | PMC |
| | — | | eTPU reg |
| | — | | eTPU PRAM |
| | — | | eTPU PRAM mirror |
| — | eTPU SCM | | |
| — | PIT_RTI | | |

Table 15-1. Peripheral Bridge Master/Slave ID Table (continued)

| Module | Internal Master ID | XBAR Port | Peripheral |
|-----------|--------------------|-----------|---------------------|
| PBRIDGE B | — | Slave 7 | PBRIDGE B |
| | — | | XBAR |
| | — | | MPU |
| | — | | SWT |
| | — | | STM |
| | — | | ESCM |
| | — | | eDMA control |
| | — | | INTC |
| | — | | eQADC A |
| | — | | eQADC B |
| | — | | Decimation Filter A |
| | — | | Decimation Filter B |
| | — | | Decimation Filter C |
| | — | | Decimation Filter D |
| | — | | DSPI A |
| | — | | DSPI B |
| | — | | DSPI C |
| | — | | DSPI D |
| | — | | eSCI A |
| | — | | eSCI B |
| | — | | eSCI C |
| | — | | FlexCAN A |
| | — | | FlexCAN B |
| | — | | FlexCAN C |
| | — | | FlexCAN D |
| | — | | FlexRay |
| | — | | Temp Sensor |
| | — | | BAM |

15.1.3 Features

The following list summarizes the key features of the PBRIDGE:

- Supports the slave interface signals. This interface is only meant for slave peripherals.

Peripheral Bridge (PBRIDGE)

- Supports 32-bit slave peripherals. Byte, 16-bit halfword, and 32-bit word reads and writes are supported to each slave peripheral.
- Supports a pair of slave accesses for 64-bit instruction fetches.
- Provides configurable per-module write buffering support.
- Provides configurable per-module and per-master access protections.

15.1.4 Modes of Operation

The PBRIDGE has only one operating mode.

15.2 External Signal Description

The PBRIDGE has no external signals.

15.3 Memory Map and Register Definitions

The memory map for the 32-bit PBRIDGE A registers is shown in [Table 15-2](#).

Table 15-2. PBRIDGE A Memory Map

| Address | Register | Bits | Access | Reset Value | Section/Page |
|------------------------|--|------|--------|-------------|-------------------------------|
| Base (0xC3F0_0000) | PBRIDGE_A_MPCR—Master privilege control register | 32 | R/W | 0x7777_7777 | 15.3.1.1/15-6 |
| Base + (0x0004–0x001F) | Reserved | | | | |
| Base + 0x0020 | PBRIDGE_A_PACR0—Peripheral access control register 0 | 32 | R/W | 0x5444_4444 | 15.3.1.2/15-7 |
| Base + (0x0024–0x003F) | Reserved | | | | |
| Base + 0x0040 | PBRIDGE_A_OPACR0—Off-platform peripheral access control register 0 | 32 | R/W | 0x4444_4444 | 15.3.1.2/15-7 |
| Base + 0x0044 | PBRIDGE_A_OPACR1—Off-platform peripheral access control register 1 | 32 | R/W | 0x4444_4444 | 15.3.1.2/15-7 |
| Base + 0x0048 | PBRIDGE_A_OPACR2—Off-platform peripheral access control register 2 | 32 | R/W | 0x4444_4444 | 15.3.1.2/15-7 |
| Base + 0x004C | PBRIDGE_A_OPACR3—Off-platform peripheral access control register 3 | 32 | R/W | 0x4444_4444 | 15.3.1.2/15-7 |
| Base + (0x0050–0x0053) | Reserved | | | | |

The memory map for the 32-bit PBRIDGE B registers is shown [Table 15-3](#).

Table 15-3. PBRIDGE B Memory Map

| Address | Register Description | Bits | Access | Reset Value | Section/Page |
|------------------------|--|------|--------|-------------|-------------------------------|
| Base (0xFFFF0_0000) | PBRIDGE_B_MPCR—Master privilege control register | 32 | R/W | 0x7777_7777 | 15.3.1.1/15-6 |
| Base + (0x0008–0x001F) | Reserved | | | | |
| Base + 0x0020 | PBRIDGE_B_PACR0—Peripheral access control register 0 | 32 | R/W | 0x5444_4444 | 15.3.1.2/15-7 |
| Base + 0x0024 | PBRIDGE_B_PACR1—Peripheral access control register 1 | 32 | R/W | 0x5444_4444 | 15.3.1.2/15-7 |
| Base + 0x0028 | PBRIDGE_B_PACR2—Peripheral access control register 2 | 32 | R/W | 0x5444_4444 | 15.3.1.2/15-7 |
| Base + (0x002C–0x003F) | Reserved | | | | |
| Base + 0x0040 | PBRIDGE_B_OPACR0—Off-platform peripheral access control register 0 | 32 | R/W | 0x4444_4444 | 15.3.1.2/15-7 |
| Base + 0x0044 | PBRIDGE_B_OPACR1—Off-platform peripheral access control register 1 | 32 | R/W | 0x4444_4444 | 15.3.1.2/15-7 |
| Base + 0x0048 | PBRIDGE_B_OPACR2—Off-platform peripheral access control register 2 | 32 | R/W | 0x4444_4444 | 15.3.1.2/15-7 |
| Base + 0x004C | PBRIDGE_B_OPACR3—Off-platform peripheral access control register 3 | 32 | R/W | 0x4444_4444 | 15.3.1.2/15-7 |
| Base + (0x0050–0x0053) | Reserved | | | | |

15.3.1 Register Descriptions

There are three types of registers that control each PBRIDGE. All registers are 32-bit registers and must be accessed in supervisor mode by trusted bus masters. Additionally, these registers must only be read from or written to by a 32-bit aligned access. PBRIDGE registers are mapped into the PBRIDGE_A and PBRIDGE_B address spaces. The protection and access fields of the MPCR, PACR, and OPACR registers are 4-bits wide. Although these registers are read/write, the reserved fields shown do not apply to this device and must remain at the reset value, therefore only write the fields' reset value to the reserved fields of these registers.

15.3.1.1 Master Privilege Control Register (PBRIDGE_x_MPCR)

The master privilege control register (PBRIDGE_x_MPCR) specifies 4-bit access fields defining the access privilege level associated with a bus master in the platform, as well as specifying whether write accesses from this master are bufferable. The registers provide one field per bus master.

Address: Base + 0x0000

Access: R/W

| | | | | | | | | | | | | | | | | |
|-------|----------------|------|------|------|----------------|------|------|------|----------------|------|------|------|----------------|----|----|----|
| | 0 | 1 | 2 | 3 | 4 | 5 | 6 | 7 | 8 | 9 | 10 | 11 | 12 | 13 | 14 | 15 |
| | Access Field 0 | | | | Access Field 1 | | | | Access Field 2 | | | | Access Field 3 | | | |
| R | MBW0 | MTR0 | MTW0 | MPL0 | MBW1 | MTR1 | MTW1 | MPL1 | 0 | 1 | 1 | 1 | 0 | 1 | 1 | 1 |
| W | | | | | | | | | | | | | | | | |
| Reset | 0 | 1 | 1 | 1 | 0 | 1 | 1 | 1 | 0 | 1 | 1 | 1 | 0 | 1 | 1 | 1 |
| | 16 | 17 | 18 | 19 | 20 | 21 | 22 | 23 | 24 | 25 | 26 | 27 | 28 | 29 | 30 | 31 |
| | Access Field 4 | | | | Access Field 5 | | | | Access Field 6 | | | | Access Field 7 | | | |
| R | MBW4 | MTR4 | MTW4 | MPL4 | MBW5 | MTR5 | MTW5 | MPL5 | MBW6 | MTR6 | MTW6 | MPL6 | 0 | 1 | 1 | 1 |
| W | | | | | | | | | | | | | | | | |
| Reset | 0 | 1 | 1 | 1 | 0 | 1 | 1 | 1 | 0 | 1 | 1 | 1 | 0 | 1 | 1 | 1 |

Figure 15-2. Master Privilege Control Registers (PBRIDGE_x_MPCR)

The following table describes the fields in the PBRIDGE master privilege control register:

Table 15-4. PBRIDGE_x_MPCR Field Descriptions

| Field | Description | | | | | | | | | | | | |
|--|---|-----------------------------|--------|---|----------|---|-------|---|--------|---|--------|---|---------|
| | <table border="1"> <thead> <tr> <th><i>n = XBAR Port Number</i></th> <th>Master</th> </tr> </thead> <tbody> <tr> <td>0</td> <td>CPU core</td> </tr> <tr> <td>1</td> <td>Nexus</td> </tr> <tr> <td>4</td> <td>eDMA A</td> </tr> <tr> <td>5</td> <td>eDMA B</td> </tr> <tr> <td>6</td> <td>FlexRay</td> </tr> </tbody> </table> | <i>n = XBAR Port Number</i> | Master | 0 | CPU core | 1 | Nexus | 4 | eDMA A | 5 | eDMA B | 6 | FlexRay |
| <i>n = XBAR Port Number</i> | Master | | | | | | | | | | | | |
| 0 | CPU core | | | | | | | | | | | | |
| 1 | Nexus | | | | | | | | | | | | |
| 4 | eDMA A | | | | | | | | | | | | |
| 5 | eDMA B | | | | | | | | | | | | |
| 6 | FlexRay | | | | | | | | | | | | |
| 0 4 16 20 24 MBW _n | Master buffer writes. Determines whether the PBRIDGE is enabled to buffer writes from the master. Buffered writes are disabled by default. 0 Buffered write accesses from the master are disabled 1 Buffered write accesses from the master are enabled | | | | | | | | | | | | |
| 1 5 17 21 25 MTR _n | Master trusted for reads. Determines whether the master is trusted for read accesses. Trusted by default. 0 Read accesses from the module are not trusted 1 Read accesses from the module are trusted | | | | | | | | | | | | |
| 2 6 18 22 26 MTW _n | Master trusted for writes. Determines whether the master is trusted for write accesses. Trusted by default. 0 Write accesses from the master are not trusted 1 Write accesses from the master are trusted | | | | | | | | | | | | |
| 3 7 19 23 27 MPL _n | Master privilege level. Determines how the privilege level of the master is determined. Accesses not forced to user mode by default. 0 Accesses from the master are forced to user mode 1 Accesses from the master are not forced to user mode | | | | | | | | | | | | |
| 8–15 28–31 | Reserved | | | | | | | | | | | | |

15.3.1.2 Peripheral Access Control Registers (PBRIDGE_x_PACR) and Off-Platform Peripheral Access Control Registers (PBRIDGE_x_OPACR)

Each of the PBRIDGE on-platform peripherals has a 4-bit access field in a peripheral access control register (PACR) that defines the access levels supported by the given module. A single PACR contains up to eight of these module-access fields, and the PACR register structure is shown in [Table 15-2](#) and [Table 15-3](#). The PACR registers with their access fields are shown in [Figure 15-3](#). There are three PACR registers, one for bridge A and two for bridge B.

Peripheral Bridge (PBRIDGE)

Also, each of the off-platform peripherals has a 4-bit access field in an off-platform peripheral access control register (PBRIDGE_x_OPACR) that defines the access levels supported by the given module. Each OPACR contains up to eight of these module-access fields, and the OPACR register structure is shown in Table 15-2 and Table 15-3. The OPACR registers with their access fields are shown in Figure 15-4.

NOTE

Write PBRIDGE_x_PACR and PBRIDGE_x_OPACR with a read/modify/write for code compatibility.

The type of peripheral designated by each PACR and OPACR access field is shown in Table 15-6.

Address: Base + 0x0020 (PBRIDGE_x_PACR0) Access: R/W
 Base + 0x0024 (PBRIDGE_B_PACR1)
 Base + 0x0028 (PBRIDGE_B_PACR2)

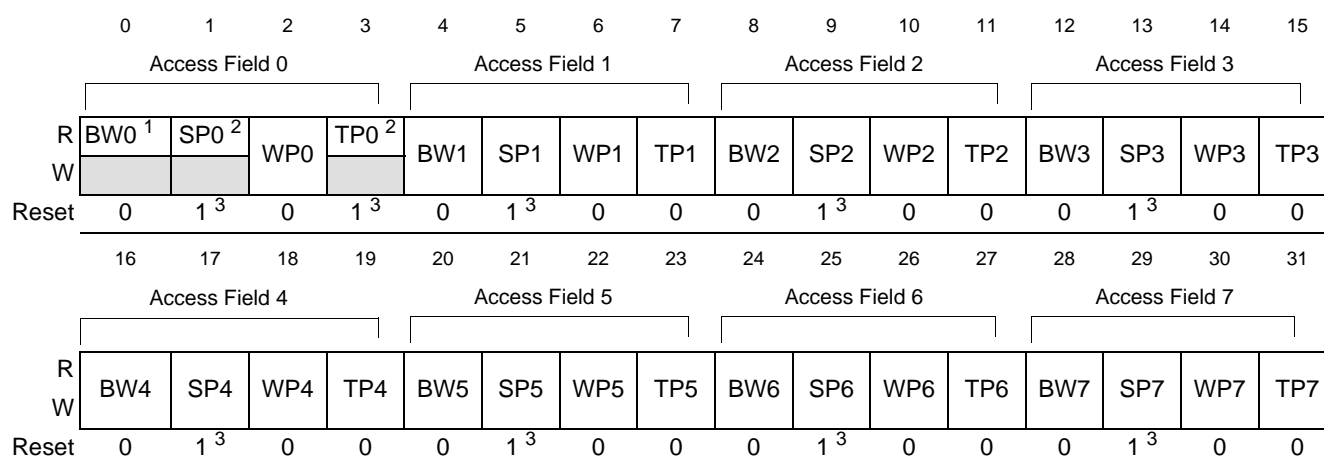

¹ In the PBRIDGE_A_PACR0 and PBRIDGE_B_PACR0 registers, the BW0 bit is not writeable.

² The default values are always used for the SP0 and TP0 bits, even though the bits are writeable.

³ The default value is 0b0000 for PACR peripheral access fields that are unused or not connected.

Figure 15-3. Peripheral Access Control Registers (PBRIDGE_x_PACRn)

Address: Base + 0x0040 (PBRIDGE_x_OPACR0); Access: R/W
 Base + 0x0044 (PBRIDGE_x_OPACR1);
 Base + 0x0048 (PBRIDGE_x_OPACR2);
 Base + 0x004C (PBRIDGE_x_OPACR3)

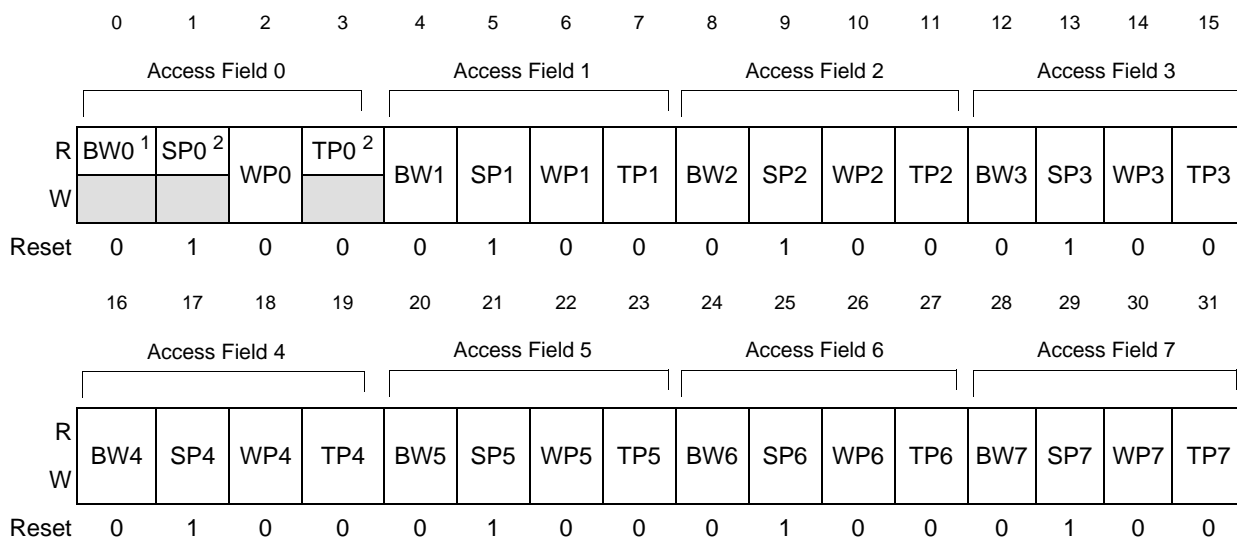

¹ In the PBRIDGE_A_PACR0 and PBRIDGE_B_PACR0 registers, the BW0 bit is not writeable
² The default values are always used for the SP0 and TP0 bits, even though the bits are writeable.

Figure 15-4. Off-platform Peripheral Access Control Registers (PBRIDGE_x_OPACRn)

Table 15-5. PBRIDGE_x_PACRn and PBRIDGE_x_OPACRn Field Descriptions

| Field | Description |
|--|---|
| 0 4 8 12 16 20 24 28 BWn | Buffer writes. Determines whether write accesses to this peripheral are allowed to be buffered. Write accesses not bufferable by default 0 No write accesses are bufferable by the PBRIDGE to this peripheral. 1 Write accesses can be buffered by the PBRIDGE to this peripheral. Note: In PBRIDGE_A_PACR0 and PBRIDGE_B_PACR0, the BW0 bit is not writeable. |
| 1 5 9 13 17 21 25 29 SPn | Supervisor protect. Determines whether the peripheral requires supervisor privilege level for access. Supervisor privilege level required by default. 0 The peripheral does not require supervisor privilege level for accesses. 1 The peripheral requires supervisor privilege level for accesses. The PBRIDGE_x_MPCR[MPLY] control bit for the master must be set. If not, access is terminated with an error response and no peripheral access is initiated on the slave bus. Note: For PBRIDGE_A_PACR0 and PBRIDGE_B_PACR0, you must have supervisor privileges to access PBRIDGE registers. Note: Even though the SP0 bit (1) is writeable, the reset value for SP0 is always used. |

Table 15-5. PBRIDGE_x_PACRn and PBRIDGE_x_OPACRn Field Descriptions (continued)

| Field | Description |
|---|---|
| 2 6 10 14 18 22 26 30 WPn | Write protect. Determines whether the peripheral allows write accesses. Write accesses allowed by default. 0 This peripheral allows write accesses. 1 This peripheral is write protected. If a write access is attempted, the access is terminated with an error response and no peripheral access is initiated on the slave bus. |
| 3 7 11 15 19 23 27 31 TPn | Trusted protect. Determines whether the peripheral allows accesses from an untrusted master. Only trusted master privileges can access this register. 0 Accesses from an untrusted master are allowed. 1 Accesses from an untrusted master are not allowed. If an access is attempted by an untrusted master, the access is terminated with an error response and no peripheral access is initiated on the slave bus. Note: For PBRIDGE_A_PACR0 and PBRIDGE_B_PACR0, you must have trusted master privileges to access PBRIDGE registers. Note: Even though the TP0 bit (1) is writeable, the reset value for TP0 is always used. |

The presence or absence of a module’s 4-bit access field in PBRIDGE_x_PACR or PBRIDGE_x_OPACR is based on whether the peripheral is present on the device. When no peripheral is connected, the field is not implemented and is read as zero. Writes are ignored.

NOTE

Table 15-6 lists all of the access fields in the PACRs and OPACRs in both PBRIDGE A and PBRIDGE B, and each of the peripherals present on the device.

Table 15-6. PACR and OPACR Access Control Registers and Peripheral Mapping

| Register | Register Address | Peripheral Access Field # | Peripheral Type | Access Field Default Value |
|------------------|-------------------------|---------------------------|-----------------|----------------------------|
| PBRIDGE A | | | | |
| PBRIDGE_A_PACR0 | PBRIDGE_A_Base + 0x0020 | 0 | PBRIDGE A | 0b0101 |
| | | 1–7 | Reserved | 0b0000 |
| PBRIDGE_A_OPACR0 | PBRIDGE_A_Base + 0x0040 | 0 | FMPLL | 0b0100 |
| | | 1 | EBI control | 0b0100 |
| | | 2 | Flash A control | 0b0100 |
| | | 3 | Flash B control | 0b0100 |
| | | 4 | SIU | 0b0100 |
| | | 5–7 | Reserved | 0b0100 |

Table 15-6. PACR and OPACR Access Control Registers and Peripheral Mapping (continued)

| Register | Register Address | Peripheral Access Field # | Peripheral Type | Access Field Default Value |
|------------------|-------------------------|---------------------------|-------------------------------|----------------------------|
| PBRIDGE_A_OPACR1 | PBRIDGE_A_Base + 0x0044 | 0 | eMIOS | 0b0100 |
| | | 1–6 | Reserved | 0b0100 |
| | | 7 | PMC | 0b0100 |
| PBRIDGE_A_OPACR2 | PBRIDGE_A_Base + 0x0048 | 0 | eTPU | 0b0100 |
| | | 1 | Reserved | 0b0100 |
| | | 2 | eTPU PRAM | 0b0100 |
| | | 3 | eTPU PRAM mirror | 0b0100 |
| | | 4–5 | eTPU SCM | 0b0100 |
| | | 6–7 | Reserved | 0b0100 |
| | | PBRIDGE_A_OPACR3 | PBRIDGE_A_Base + 0x004C | 0–3 |
| 4 | PIT/RTI | | | 0b0100 |
| 5–7 | Reserved | | | 0b0100 |
| PBRIDGE B | | | | |
| PBRIDGE_B_PACR0 | PBRIDGE_B_Base + 0x0020 | 0 | PBRIDGE B | 0b0101 |
| | | 1 | XBAR | 0b0100 |
| | | 2–3 | Reserved | 0b0000 |
| | | 4 | MPU | 0b0100 |
| | | 5–7 | Reserved | 0b0000 |
| PBRIDGE_B_PACR1 | PBRIDGE_B_Base + 0x0024 | 0–5 | Reserved | 0b0000 |
| | | 6 | SWT | 0b0100 |
| | | 7 | STM | 0b0100 |
| PBRIDGE_B_PACR2 | PBRIDGE_B_Base + 0x0028 | 0 | ESCM | 0b0100 |
| | | 1 | eDMA A | 0b0100 |
| | | 2 | INTC | 0b0100 |
| | | 3–4 | Reserved | 0b0100 |
| | | 5 | eDMA B | 0b0100 |
| | | 6–7 | Reserved | 0b0000 |
| PBRIDGE_B_OPACR0 | PBRIDGE_B_Base + 0x0040 | 0 | eQADC A | 0b0100 |
| | | 1 | eQADC B | 0b0100 |
| | | 2 | Decimation Filters A, B, C, D | 0b0100 |
| | | 3 | Reserved | 0b0100 |
| | | 4 | DSPI A | 0b0100 |
| | | 5 | DSPI B | 0b0100 |
| | | 6 | DSPI C | 0b0100 |
| | | 7 | DSPI D | 0b0100 |

Table 15-6. PACR and OPACR Access Control Registers and Peripheral Mapping (continued)

| Register | Register Address | Peripheral Access Field # | Peripheral Type | Access Field Default Value |
|------------------|-------------------------|---------------------------|-----------------|----------------------------|
| PBRIDGE_B_OPACR1 | PBRIDGE_B_Base + 0x0044 | 0–3 | Reserved | 0b0100 |
| | | 4 | eSCI A | 0b0100 |
| | | 5 | eSCI B | 0b0100 |
| | | 6 | eSCI C | 0b0100 |
| | | 7 | Reserved | 0b0100 |
| PBRIDGE_B_OPACR2 | PBRIDGE_B_Base + 0x0048 | 0 | FlexCAN A | 0b0100 |
| | | 1 | FlexCAN B | 0b0100 |
| | | 2 | FlexCAN C | 0b0100 |
| | | 3 | FlexCAN D | 0b0100 |
| | | 4–7 | Reserved | 0b0100 |
| PBRIDGE_B_OPACR3 | PBRIDGE_B_Base + 0x004C | 0 | FlexRay | 0b0100 |
| | | 1–2 | Reserved | 0b0100 |
| | | 3 | Temp Sensor | 0b0100 |
| | | 4-6 | Reserved | 0b0100 |
| | | 7 | BAM | 0b0100 |

15.4 Functional Description

The PBRIDGE serves as an interface between a system bus and the peripheral (slave) bus. It functions as a protocol translator. Support is provided for generating a pair of 32-bit peripheral accesses when targeted by a 64-bit system bus instruction access. No other bus-sizing access support is provided.

Accesses that fall within the address space of the PBRIDGE are decoded to provide individual module selects for peripheral devices on the slave bus interface.

15.4.1 Access Support

Aligned 64-bit instruction accesses, aligned word and halfword accesses, as well as byte accesses are supported for 32-bit peripherals. Do not misalign instruction accesses to peripheral registers, although no explicit checking is performed by the PBRIDGE.

NOTE

Data accesses that cross a 32-bit boundary are not supported.

15.4.2 Peripheral Write Buffering

The PBRIDGE provides programmable write buffering capability to buffer write accesses in the PBRIDGE for later completion, while terminating the system bus access early. This provides improved performance in systems where frequent writes to a slow peripheral occur.

Write buffering is controllable on a per-master and per-peripheral basis. Enable write buffering for masters and peripherals only when an error termination from the slave bus does not occur or is safe to ignore. When write buffering is enabled, all accesses through the PBRIDGE must occur in sequence; bypassing buffered writes is *not* supported.

NOTE

The core detects that the write buffering is complete before the write actually completes in the peripheral. If write buffering is enabled for a peripheral, the actual write takes an additional two system clock cycles plus any additional system clock cycles the register requires. Most registers in the MPC5500 family delay the write by two clock cycles, but some registers take longer. This early termination, as detected by the core, can defeat the **mbar** or **msync** instruction between the write to clear a flag bit and the write to the INTC_EOIR. Therefore, if write buffering is enabled for a peripheral that has a flag bit, insert instructions between the **mbar** or **msync** instruction and the write to the INTC_EOIR that consumes at least the number of system clock cycles that the actual write is delayed.

15.4.2.1 Read Cycles

Read accesses are possible with the PBRIDGE when the requested access size is 32-bits or smaller, and is not misaligned across a 32-bit boundary. 64-bit data reads (not instruction) are not supported.

15.4.2.2 Write Cycles

Write accesses are possible with the PBRIDGE when the requested access size is 32-bits or smaller. Misaligned writes that cross a 32-bit boundary are not supported. 64-bit data writes (not instruction) are not supported.

15.4.2.3 Buffered Write Cycles

Single clock write responses to the system bus are possible with the PBRIDGE when the requested write access is bufferable. If the requested access does not violate the permissions check, and if both master and peripheral are enabled for buffering writes, the PBRIDGE internally buffers the write cycle. The write cycle is terminated early with zero system bus wait states. The access proceeds normally on the slave interface, but error responses are ignored.

All accesses are initiated and completed in order on the slave interface, regardless of buffering. If the buffer is full, a following write cycle stalls until it can either be buffered (if bufferable) or can be initiated. If the buffer has valid entries, a following read cycle stalls until the buffer is emptied and the read cycle can be completed.

15.4.3 General Operation

Slave peripherals are modules that contain readable/writable control and status registers. The system bus master reads and writes these registers through the PBRIDGE. The PBRIDGE generates module enables, the module address, transfer attributes, byte enables, and write data as inputs to the slave peripherals. The PBRIDGE captures read data from the slave interface and drives it on the system bus.

Separate interface ports are provided for on-platform and off-platform peripherals. The distinction between on-platform and off-platform is made to allow platform-based designs incorporating the PBRIDGE to separate the interface ports to allow for ease of timing closure. In addition, module selects and control register storage for on-platform peripherals are allocated at synthesis time, allowing only needed resources to be implemented. Off-platform module selects and control register storage do not have the same degree of configurability.

The modules that are on-platform and those that are off-platform are detailed in [Table 15-7](#).

Table 15-7. On-Platform and Off-Platform Peripherals

| On-Platform | Off-Platform |
|---------------------------------------|---|
| Enhanced direct memory access (eDMA) | Deserial serial peripheral interface (DSPI) |
| PBRIDGE A and B | Enhanced queued analog-to-digital converter (eQADC) |
| Interrupt controller (INTC) | Enhanced serial communication interface (eSCI) |
| Error correction status module (ECSM) | FlexCAN controller area network |
| System bus crossbar switch (XBAR) | Boot assist module (BAM) |
| Memory Protection Unit (MPU) | System integration unit (SIU) |
| Software Watchdog Timer (SWT) | Enhanced modular input/output subsystem (eMIOS) |
| System Timer Module (STM) | Frequency modulated phase locked loop (FMPLL) |
| | Enhanced time processing unit (eTPU) |
| | External bus interface (EBI) |
| | Flash bus interface unit (FBIU) |
| | FlexRay |
| | Power Management Controller (PMC) |
| | PIT_RTI |
| | Decimation Filters |
| | Temp Sensor |

PBRIDGE occupies a 64 MB portion of the address space. A 0.5 MB portion of this space is allocated to on-platform peripherals. The remaining 63.5 MB is available for off-platform devices. The register maps of the slave peripherals are located on 16-KB boundaries. Each slave peripheral is allocated one 16-KB block of the memory map, and is activated by one of the module enables from the PBRIDGE. Up to thirty-two 16-KB external slave peripherals can be implemented, occupying contiguous blocks of 16 KB. Two global external slave module enables are available for the remaining 63 MB of address space to allow for customization and expansion of addressed peripheral devices. In addition, a single non-global module enable is also asserted whenever any of the 32 non-global module enables is asserted.

PBRIDGE is responsible for indicating to slave peripherals if an access is in supervisor or user mode. The PBRIDGE can block user mode accesses to certain slave peripherals or it can allow the individual slave peripherals to determine if user mode accesses are allowed. In addition, peripherals can be designated as write-protected. The PBRIDGE supports the notion of trusted masters for security purposes. Masters can be individually designated as trusted for reads, trusted for writes, or trusted for both reads and writes, as well as being forced to look as though all accesses from a master are in user mode privilege level.

PBRIDGE also supports buffered writes, allowing write accesses to be terminated on the system bus in a single clock cycle, and then subsequently performed on the slave interface. Write buffering is controllable on a per-peripheral basis. The PBRIDGE implements a two-entry 32-bit write buffer.



Chapter 16

Memory Protection Unit (MPU)

16.1 Introduction

The memory protection unit (MPU) provides hardware access control for all memory references generated in a device. Using pre-programmed region descriptors that define memory spaces and their associated access rights, the MPU concurrently monitors all system bus transactions and evaluates the appropriateness of each transfer. Memory references with sufficient access control rights are allowed to complete, but references that are not mapped to any region descriptor or have insufficient rights are terminated with a protection error response.

The MPU implements a set of program-visible region descriptors that monitor all system bus addresses. The result is a hardware structure with a two-dimensional connection matrix, where the region descriptors represent one dimension and the individual system bus addresses and attributes are the second dimension.

16.1.1 Block Diagram

A simplified block diagram illustrates how the MPU block is connected to the four XBAR MPU ports and the shared port splitter (see [Figure 16-1](#) and [Table 16-1](#)).

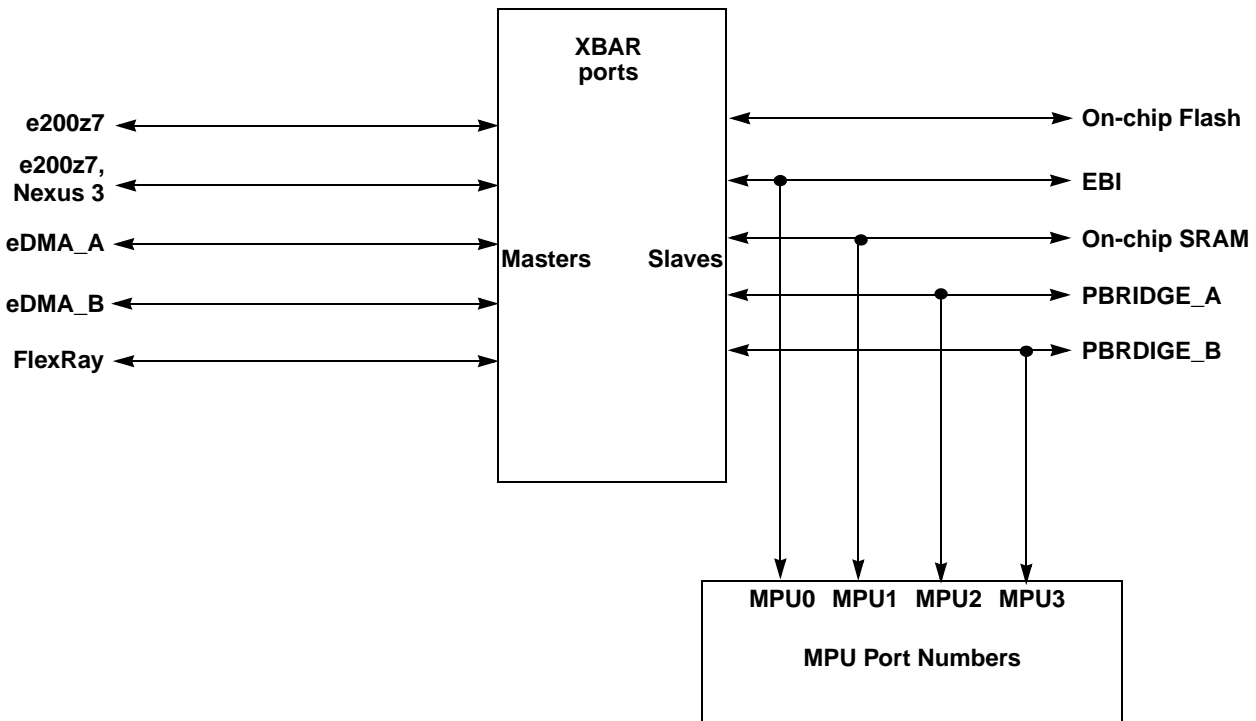

Figure 16-1. MPU Connections to XBAR Slaves

[Table 16-1](#) enumerates the MPU Ports that are attached to slave modules. The Master IDs of all bus master modules are also shown, as their values are required to configure certain MPU registers described in this chapter.

Table 16-1. XBAR Switch Ports

| Module | MPU Master ID | MPU Slave Port |
|---------------------------------|---------------|----------------|
| e200z7 core—CPU instruction | 0 | — |
| e200z7—Data | 0 | — |
| Nexus 3 | 0 | — |
| eDMA_A | 4 | — |
| eDMA_B | 5 | — |
| FlexRay | 6 | — |
| On-chip Flash | — | — |
| EBI (development bus) | — | 0 |
| On-chip SRAM | — | 1 |
| Peripheral bridge A (PBRIDGE_A) | — | 2 |
| Peripheral bridge B (PBRIDGE_B) | — | 3 |

16.1.2 Features

The MPU has these major features:

- Support for 16 memory region descriptors, each 128 bits in size
 - Specification of start and end addresses provide granularity for region sizes from 32 bytes to 4 GB
 - MPU is invalid at reset, thus no access restrictions are enforced
 - Two types of access control definitions: processor core bus master (e200z7) supports the traditional {read, write, execute} permissions with independent definitions for supervisor and user mode accesses; the remaining non-core bus masters (eDMA_A, eDMA_B, FlexRay) support {read, write} attributes
 - Automatic hardware maintenance of the region descriptor valid bit removes issues associated with maintaining a coherent image of the descriptor
 - Alternate memory view of the access control word for each descriptor provides an efficient mechanism to dynamically alter the access rights of a descriptor only
 - For overlapping region descriptors, priority is given to permission granting over access denying as this approach provides more flexibility to system software
- Support for four AHB slave port connections
 - PBRIDGE_A, PBRIDGE_B, EBI (development bus), general purpose SRAM
 - MPU hardware monitors every AHB slave port access using the pre-programmed memory region descriptors
 - An access protection error is detected if a memory reference does not hit in any memory region or the reference is flagged as illegal in all memory regions where it does hit; in the event of an access error, the AHB reference is terminated with an error response and the MPU inhibits the bus cycle being sent to the targeted slave device
 - 64-bit error registers, one for each AHB slave port, capture the last faulting address, attributes, and detail information

16.2 Memory Map and Registers

This section provides a detailed description of all MPU registers.

16.2.1 Module Memory Map

The MPU memory map is shown in [Table 16-2](#). The address of each register is given as an offset to the MPU base address. Registers are listed in address order, identified by complete name and mnemonic, and list the type of accesses allowed.

The MPU registers can be referenced using 32-bit (word) accesses only. Attempted references using different access sizes, to undefined (reserved) addresses, or with a non-supported access type (for example, a write to a read-only register or a read of a write-only register) generate an error termination.

Table 16-2. MPU Memory Map

| Offset from MPU_BASE (0xFFF1_0000) | Register | Bits | Access | Reset Value | Section/Page |
|------------------------------------|---|------|--------|----------------|-------------------------------|
| 0x0000 | MPU_CESR — MPU control/error status register | 32 | R/W | 0x0081_4200 | 16.2.2.1/16-6 |
| 0x0004–0x000F | Reserved | | | | |
| 0x0010 | MPU_EAR0 — MPU error address register, MPU port 0 | 32 | R | — ¹ | 16.2.2.2/16-7 |
| 0x0014 | MPU_EDR0 — MPU error detail register, MPU port 0 | 32 | R | — ¹ | 16.2.2.3/16-7 |
| 0x0018 | MPU_EAR1 — MPU error address register, MPU port 1 | 32 | R | — ¹ | 16.2.2.2/16-7 |
| 0x001C | MPU_EDR1 — MPU error detail register, MPU port 1 | 32 | R | — ¹ | 16.2.2.3/16-7 |
| 0x0020 | MPU_EAR2 — MPU error address register, MPU port 2 | 32 | R | — ¹ | 16.2.2.2/16-7 |
| 0x0024 | MPU_EDR2 — MPU error detail register, MPU port 2 | 32 | R | — ¹ | 16.2.2.3/16-7 |
| 0x0028 | MPU_EAR3 — MPU error address register, MPU port 3 | 32 | RO | — ¹ | 16.2.2.2/16-7 |
| 0x002C | MPU_EDR3 — MPU error detail register, MPU port 3 | 32 | RO | — ¹ | 16.2.2.3/16-7 |
| 0x0030–0x03FF | Reserved | | | | |
| 0x0400 | MPU_RGD0 — MPU region descriptor 0 | 32 | R/W | — ¹ | 16.2.2.4/16-8 |
| 0x0410 | MPU_RGD1 — MPU region descriptor 1 | 32 | R/W | — ¹ | 16.2.2.4/16-8 |
| 0x0420 | MPU_RGD2 — MPU region descriptor 2 | 32 | R/W | — ¹ | 16.2.2.4/16-8 |
| 0x0430 | MPU_RGD3 — MPU region descriptor 3 | 32 | R/W | — ¹ | 16.2.2.4/16-8 |
| 0x0440 | MPU_RGD4 — MPU region descriptor 4 | 32 | R/W | — ¹ | 16.2.2.4/16-8 |
| 0x0450 | MPU_RGD5 — MPU region descriptor 5 | 32 | R/W | — ¹ | 16.2.2.4/16-8 |
| 0x0460 | MPU_RGD6 — MPU region descriptor 6 | 32 | R/W | — ¹ | 16.2.2.4/16-8 |
| 0x0470 | MPU_RGD7 — MPU region descriptor 7 | 32 | R/W | — ¹ | 16.2.2.4/16-8 |
| 0x0480 | MPU_RGD8 — MPU region descriptor 8 | 32 | R/W | — ¹ | 16.2.2.4/16-8 |

Table 16-2. MPU Memory Map (continued)

| Offset from MPU_BASE (0xFFFF1_0000) | Register | Bits | Access | Reset Value | Section/Page |
|-------------------------------------|--|------|--------|----------------|----------------|
| 0x0490 | MPU_RGD9 — MPU region descriptor 9 | 32 | R/W | — ¹ | 16.2.2.4/16-8 |
| 0x04A0 | MPU_RGD10 — MPU region descriptor 10 | 32 | R/W | — ¹ | 16.2.2.4/16-8 |
| 0x04B0 | MPU_RGD11 — MPU region descriptor 11 | 32 | R/W | — ¹ | 16.2.2.4/16-8 |
| 0x04C0 | MPU_RGD12 — MPU region descriptor 12 | 32 | R/W | — ¹ | 16.2.2.4/16-8 |
| 0x04D0 | MPU_RGD13 — MPU region descriptor 13 | 32 | R/W | — ¹ | 16.2.2.4/16-8 |
| 0x04E0 | MPU_RGD14 — MPU region descriptor 14 | 32 | R/W | — ¹ | 16.2.2.4/16-8 |
| 0x04F0 | MPU_RGD15 — MPU region descriptor 15 | 32 | R/W | — ¹ | 16.2.2.4/16-8 |
| 0x00500–0x07FF | Reserved | | | | |
| 0x0800 | MPU_RGDAAC0 — MPU RGD alternate access control 0 | 32 | W | — ¹ | 16.2.2.5/16-13 |
| 0x0804 | MPU_RGDAAC1 — MPU RGD alternate access control 1 | 32 | W | — ¹ | 16.2.2.5/16-13 |
| 0x0808 | MPU_RGDAAC2 — MPU RGD alternate access control 2 | 32 | W | — ¹ | 16.2.2.5/16-13 |
| 0x080C | MPU_RGDAAC3 — MPU RGD alternate access control 3 | 32 | W | — ¹ | 16.2.2.5/16-13 |
| 0x0810 | MPU_RGDAAC4 — MPU RGD alternate access control 4 | 32 | W | — ¹ | 16.2.2.5/16-13 |
| 0x0814 | MPU_RGDAAC5 — MPU RGD alternate access control 5 | 32 | W | — ¹ | 16.2.2.5/16-13 |
| 0x0818 | MPU_RGDAAC6 — MPU RGD alternate access control 6 | 32 | W | — ¹ | 16.2.2.5/16-13 |
| 0x081C | MPU_RGDAAC7 — MPU RGD alternate access control 7 | 32 | W | — ¹ | 16.2.2.5/16-13 |
| 0x0820 | MPU_RGDAAC8 — MPU RGD alternate access control 8 | 32 | W | — ¹ | 16.2.2.5/16-13 |
| 0x0824 | MPU_RGDAAC9 — MPU RGD alternate access control 9 | 32 | W | — ¹ | 16.2.2.5/16-13 |
| 0x0828 | MPU_RGDAAC10 — MPU RGD alternate access control 10 | 32 | W | — ¹ | 16.2.2.5/16-13 |
| 0x082C | MPU_RGDAAC11 — MPU RGD alternate access control 11 | 32 | W | — ¹ | 16.2.2.5/16-13 |
| 0x0830 | MPU_RGDAAC12 — MPU RGD alternate access control 12 | 32 | W | — ¹ | 16.2.2.5/16-13 |
| 0x0834 | MPU_RGDAAC13 — MPU RGD alternate access control 13 | 32 | W | — ¹ | 16.2.2.5/16-13 |
| 0x0838 | MPU_RGDAAC14 — MPU RGD alternate access control 14 | 32 | W | — ¹ | 16.2.2.5/16-13 |

Table 16-2. MPU Memory Map (continued)

| Offset from MPU_BASE (0xFFFF1_0000) | Register | Bits | Access | Reset Value | Section/Page |
|-------------------------------------|--|------|--------|----------------|----------------|
| 0x083C | MPU_RGDAAC15 — MPU RGD alternate access control 15 | 32 | W | — ¹ | 16.2.2.5/16-13 |
| 0x0840–0x08FF | Reserved | | | | |

¹ See register definition.

16.2.2 Register Descriptions

This section lists the MPU registers in address order and describes the registers and their bit fields.

16.2.2.1 MPU Control/Error Status Register (MPU_CESR)

The MPU_CESR provides one byte of error status and three bytes of configuration information. A global MPU enable/disable bit is also included in this register.

Offset: MPU_BASE+0x0000

Access: User read/write

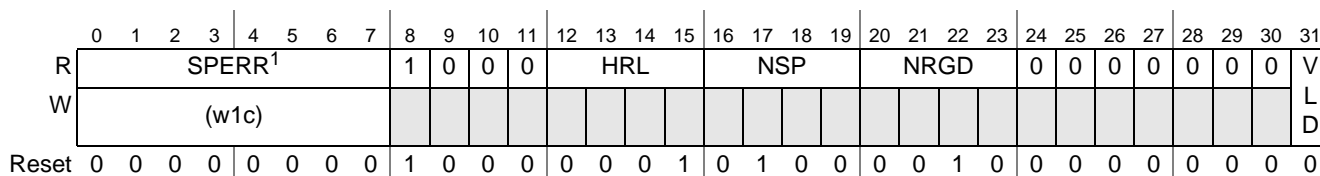

Figure 16-2. MPU Control/Error Status Register (MPU_CESR)

¹ Each SPERR bit can be cleared by writing a one to the bit location.

Table 16-3. MPU_CESR Bit Field Descriptions

| Field | Description |
|--------------|--|
| 0–7 SPERR | MPU port <i>n</i> Error (where the MPU port number matches the bit number (see Figure 16-1)). Each bit in this read-only field represents a flag maintained by the MPU for signaling the presence of a captured error contained in the MPU_EAR <i>n</i> and MPU_EDR <i>n</i> registers. The individual bit is set when the hardware detects an error and records the faulting address and attributes. It is cleared when the corresponding bit is written to a logical one. If another error is captured at the exact same cycle as a write of a logical one, this flag remains set. A find-first-one instruction (or equivalent) can be used to detect the presence of a captured error. 0 The corresponding MPU_EAR <i>n</i> /MPU_EDR <i>n</i> registers do not contain an unread captured error 1 The corresponding MPU_EAR <i>n</i> /MPU_EDR <i>n</i> registers do contain an unread captured error Note: Bit 0 indicates an EBI protection error, bit 1 indicates an SRAM protection error, bit 2 indicates a peripheral bridge B protection error, and bit 3 indicates a peripheral bridge A protection error. |
| 8–11 | Reserved |
| 12–15 HRL | Hardware Revision Level. This 4-bit read-only field specifies the MPU's hardware and definition revision level. It can be read by software to determine the functional definition of the module. This field reads as 0 on this device. |
| 16–19 NSP | Number of MPU ports. This 4-bit read-only field specifies the number of slave ports connected to the MPU. This field reads as 0b0100 on this device. |

Table 16-3. MPU_CESR Bit Field Descriptions (continued)

| Field | Description |
|---------------|---|
| 20–23 NRGD | Number of Region Descriptors. This 4-bit read-only field specifies the number of region descriptors implemented in the MPU. The defined encodings include: 0000 8 region descriptors 0010 16 region descriptors This field reads as 0b0010 on this device. |
| 24–30 | Reserved |
| 31 VLD | Valid. This bit provides a global enable/disable for the MPU. 0 The MPU is disabled 1 The MPU is enabled While the MPU is disabled, all accesses from all bus masters are allowed. |

16.2.2.2 MPU Error Address Register, MPU Port 0 to 3 (MPU_EAR_n)

When the MPU detects an access error on MPU port *n*, the 32-bit reference address is captured in this read-only register and the corresponding bit in the MPU_CESR[SPERR] field set. Additional information about the faulting access is captured in the corresponding MPU_EDR_n register at the same time.

Offset: MPU_BASE + 0x0010 (MPU_EAR0) Access: User read only
 MPU_BASE + 0x0018 (MPU_EAR1)
 MPU_BASE + 0x0020 (MPU_EAR2)
 MPU_BASE + 0x0028 (MPU_EAR3)

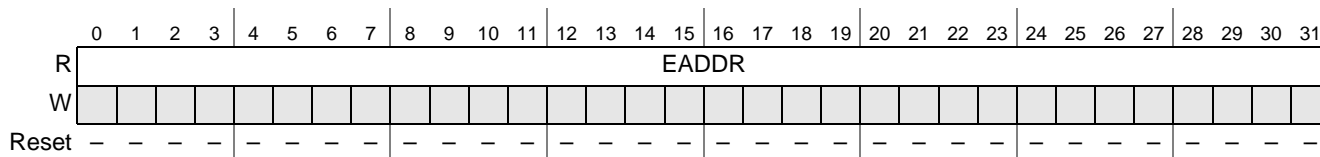
Figure 16-3. MPU Error Address Register, MPU Port *n* (MPU_EAR_n)
Table 16-4. MPU_EAR Bit Field Descriptions

| Field | Description |
|---------------|--|
| 0–31 EADDR | Error Address. This read-only field is the reference address from MPU port <i>n</i> that generated the access error. |

16.2.2.3 MPU Error Detail Register, MPU Port 0 to 3 (MPU_EDR_n)

When the MPU detects an access error on MPU port *n*, 32 bits of error detail are captured in this read-only register and the corresponding bit in the MPU_CESR[SPERR] field set. Information on the faulting address is captured in the corresponding MPU_EAR_n register at the same time. A read of the MPU_EDR_n register clears the corresponding bit in the MPU_CESR[SPERR] field.

Offset: MPU_BASE + 0x00014 (MPU_EDR0) Access: User read only
 MPU_BASE + 0x0001C (MPU_EDR1)
 MPU_BASE + 0x00024 (MPU_EDR2)
 MPU_BASE + 0x0002C (MPU_EDR3)

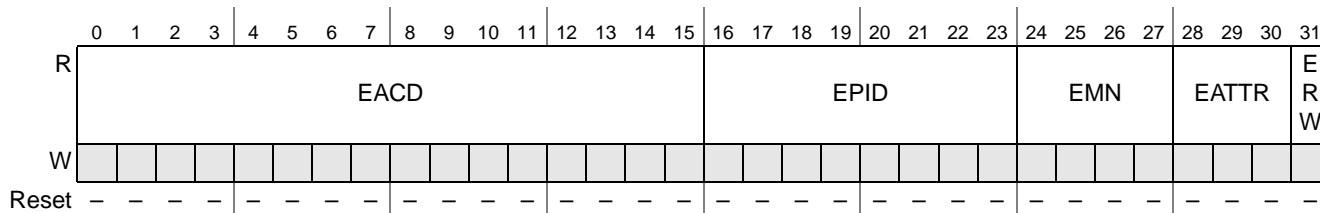

Figure 16-4. MPU Error Detail Register, MPU Port *n* (MPU_EDR*n*)

Table 16-5. MPU_EDR Bit Field Descriptions

| Field | Description |
|----------------|---|
| 0–15 EACD | Error Access Control Detail. This 16-bit read-only field implements one bit per region descriptor and is an indication of the region descriptor hit logically-ANDed with the access error indication. The MPU performs a reference-by-reference evaluation to determine the presence/absence of an access error. When an error is detected, the hit-qualified access control vector is captured in this field. If the MPU_EDR <i>n</i> register contains a captured error and the EACD field is all zeroes, this signals an access that did not hit in any region descriptor. All non-zero EACD values signal references that hit in a region descriptor(s), but failed due to a protection error as defined by the specific set bits. |
| 16–23 EPID | Error Process Identification. This 8-bit read-only field records the process identifier of the faulting reference. The process identifier is typically driven by processor cores only; for other bus masters, this field is cleared. |
| 24–27 EMN | Error Master Number. This 4-bit read-only field records the logical master number of the faulting reference. This field is used to determine the bus master that generated the access error. |
| 28–30 EATTR | Error Attributes. This 3-bit read-only field records attribute information about the faulting reference. The supported encodings are defined as: 000 User mode, instruction access 001 User mode, data access 010 Supervisor mode, instruction access 011 Supervisor mode, data access All other encodings are reserved. For non-core bus masters, the access attribute information is typically wired to supervisor, data (0b011). |
| 31 ERW | Error Read/Write. This 1-bit read-only field signals the access type (read, write) of the faulting reference. 0 Read 1 Write |

16.2.2.4 MPU Region Descriptor *n* (MPU_RGD*n*)

Each 128-bit (16 byte) region descriptor specifies a given memory space and the access attributes associated with that space. The descriptor definition is fundamental to the operation of the MPU.

The region descriptors are organized sequentially in the MPU’s programming model and each of the four 32-bit words are detailed in the subsequent sections.

16.2.2.4.1 MPU Region Descriptor n , Word 0 (MPU_RGD n .Word0)

The first word of the MPU region descriptor defines the 0-modulo-32 byte start address of the memory region. Writes to this word clear the region descriptor's valid bit.

Offset: MPU_BASE + 0x400 + (16* n) + 0x0 (MPU_RGD n .Word0) Access: User read/write

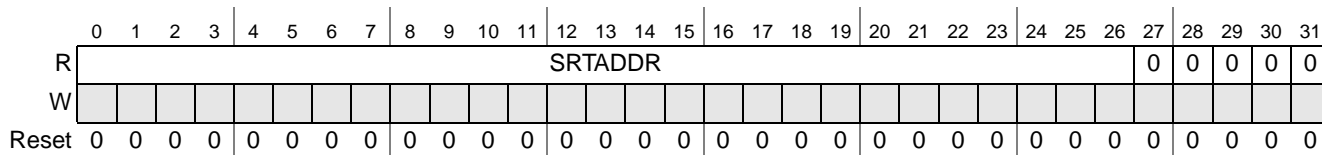

Figure 16-5. MPU Region Descriptor, Word 0 Register (MPU_RGD n .Word0)

Table 16-6. MPU_RGD Word 0 Description

| Field | Description |
|-----------------|---|
| 0–26 SRTADDR | Start Address. This field defines the most significant bits of the 0-modulo-32 byte start address of the memory region. |
| 27–31 | Reserved |

16.2.2.4.2 MPU Region Descriptor n , Word 1 (MPU_RGD n .Word1)

The second word of the MPU region descriptor defines the 31-modulo-32 byte end address of the memory region. Writes to this word clear the region descriptor's valid bit.

Offset: MPU_BASE + 0x400 + (16* n) + 0x4 (MPU_RGD n .Word1) Access: User read/write

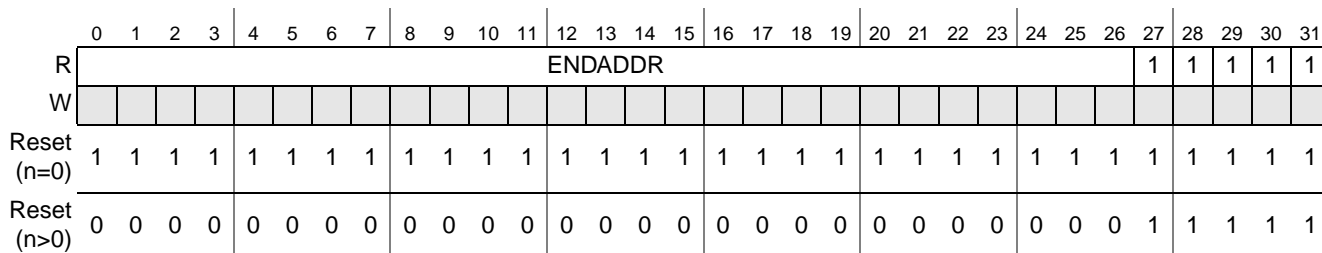

Figure 16-6. MPU Region Descriptor, Word 1 Register (MPU_RGD n .Word1)

Table 16-7. MPU_RGD Word 1 Description

| Field | Description |
|-----------------|--|
| 0–26 ENDADDR | End Address. This field defines the most significant bits of the 31-modulo-32 byte end address of the memory region. There are no hardware checks to verify that ENDADDR \geq SRTADDR; the software must properly load these region descriptor fields. |
| 27–31 | Reserved |

16.2.2.4.3 MPU Region Descriptor n , Word 2 (MPU_RGD n .Word2)

The third word of the MPU region descriptor defines the access control rights of the memory region. The access control privileges are dependent on two broad classifications of bus masters. Bus masters 0–3 are typically reserved for processor cores. The corresponding access control is a 6-bit field defining separate privilege rights for user and supervisor mode accesses as well as the optional inclusion of a process

identification field within the definition. Bus masters 4–7 are typically reserved for data movement engines and their capabilities are limited to separate read and write permissions. For these fields, the bus master number refers to the logical master number defined as the AHB $hmaster[3:0]$ signal.

For the processor privilege rights, there are three flags associated with this function: {read, write, execute}. In this context, these flags follow the traditional definition:

- Read (r) permission refers to the ability to access the referenced memory address using an operand (data) fetch.
- Write (w) permission refers to the ability to update the referenced memory address using a store (data) instruction.
- Execute (x) permission refers to the ability to read the referenced memory address using an instruction fetch.

The evaluation logic defines the processor access type based on multiple AHB signals: read or write as specified by the $hwrite$ signal and the low-order two bits of $hprot[1:0]$, which identify a data reference versus an instruction fetch and the operating mode (supervisor, user) of the requesting processor.

For non-processor data movement engines (bus masters 4–7), the evaluation logic simply uses $hwrite$ to determine if the access is a read or write. The $hprot[1:0]$ signal is ignored for these masters.

Writes to this word clear the region descriptor’s valid bit. Because it is also expected that system software may adjust only the access controls within a region descriptor (MPU_RGD n .Word2) as different tasks execute, an alternate programming view of this 32-bit entity is provided. If only the access controls are being updated, this operation should be performed by writing to MPU_RGDAAC n (alternate access control n) as stores to these locations do not affect the descriptor’s valid bit.

Offset: MPU_BASE + 0x400 + (16*n) + 0x8 (MPU_RGD n .Word2) Access: User read/write

| | | | | | | | | | | | | | | | | |
|-------------|---|---|------|------|------|------|------|------|---|---|----|----|----|----|----|----|
| | 0 | 1 | 2 | 3 | 4 | 5 | 6 | 7 | 8 | 9 | 10 | 11 | 12 | 13 | 14 | 15 |
| R | 0 | 0 | M6RE | M6WE | M5RE | M5WE | M4RE | M4WE | 0 | 0 | 0 | 0 | 0 | 0 | 0 | 0 |
| W | | | | | | | | | | | | | | | | |
| Reset (n=0) | 0 | 0 | 0 | 0 | 0 | 0 | 0 | 0 | 0 | 1 | 1 | 0 | 0 | 0 | 0 | 1 |
| Reset (n>0) | 0 | 0 | 0 | 0 | 0 | 0 | 0 | 0 | 0 | 0 | 0 | 0 | 0 | 0 | 0 | 0 |

| | | | | | | | | | | | | | | | | |
|-------------|----|----|----|----|----|----|----|----|----|----|------|------|------|----|----|----|
| | 16 | 17 | 18 | 19 | 20 | 21 | 22 | 23 | 24 | 25 | 26 | 27 | 28 | 29 | 30 | 31 |
| R | 0 | 0 | 0 | 0 | 0 | 0 | 0 | 0 | 0 | 0 | MOPE | MOSM | MOUM | | | |
| W | | | | | | | | | | | | | r | w | x | |
| Reset (n=0) | 1 | 0 | 0 | 0 | 0 | 1 | 1 | 0 | 0 | 0 | 0 | 0 | 0 | 0 | 0 | 0 |
| Reset (n>0) | 0 | 0 | 0 | 0 | 0 | 0 | 0 | 0 | 0 | 0 | 0 | 0 | 0 | 0 | 0 | 0 |

Note: Refer to [Table 16-1](#) to see the Master ID assignments.

Figure 16-7. MPU Region Descriptor, Word 2 Register (MPU_RGD n .Word2)

Table 16-8. MPU_RGD Word 2 Description

| Field | Description |
|---------------------|--|
| | Note: For future code compatibility, do not change the value of reserved bits from their reset value |
| 0–1 | Reserved |
| 2 4 6 MnRE | Bus Master ID <i>n</i> Read Enable. If set, this flag allows bus master ID <i>n</i> to perform read operations. If cleared, any attempted read by bus master ID <i>n</i> terminates with an access error and the read is not performed. Note: See Table 16-1 for the MPU Master ID list. |
| 3 5 7 MnWE | Bus Master ID <i>n</i> Write Enable. If set, this flag allows bus master ID <i>n</i> to perform write operations. If cleared, any attempted write by bus master ID <i>n</i> terminates with an access error and the write is not performed. Note: See Table 16-1 for the MPU Master ID list. |
| 8–25 | Reserved |
| 26 M0PE | Bus Master ID 0 Process Identifier Enable. If set, this flag specifies that the process identifier and mask defined in MPU_RGD _{<i>n</i>} .Word3 are to be included in the region hit evaluation. If cleared, the region hit evaluation does not include the process identifier. Note: See Table 16-1 for the MPU Master ID list. |
| 27–28 M0SM | Bus Master ID 0 Supervisor Mode Access Control. This 2-bit field defines the access controls for bus master ID 0 when operating in supervisor mode. The M0SM field is defined as: 00 <i>r, w, x</i> = read, write and execute allowed 01 <i>r, -, x</i> = read and execute allowed, but no write 10 <i>r, w, -</i> = read and write allowed, but no execute 11 Same access controls as that defined by M0UM for user mode Note: See Table 16-1 for the MPU Master ID list. |
| 29–31 M0UM | Bus Master ID 0 User Mode Access Control. This 3-bit field defines the access controls for bus master ID 0 when operating in user mode. The M0UM field consists of three independent bits, enabling read, write, and execute permissions: { <i>r, w, x</i> }. If set, the bit allows the given access type to occur; if cleared, an attempted access of that mode may be terminated with an access error (if not allowed by any other descriptor) and the access not performed. Note: See Table 16-1 for the MPU Master ID list. |

16.2.2.4.4 MPU Region Descriptor *n*, Word 3 (MPU_RGD*n*.Word3)

The fourth word of the MPU region descriptor contains the optional process identifier and mask, plus the region descriptor’s valid bit.

Because the region descriptor is a 128-bit entity, there are potential coherency issues as this structure is being updated because multiple writes are required to update the entire descriptor. Accordingly, the MPU hardware assists in the operation of the descriptor valid bit to prevent incoherent region descriptors from generating spurious access errors. In particular, it is expected that a complete update of a region descriptor is typically done with sequential writes to MPU_RGD*n*.Word0, then MPU_RGD*n*.Word1, ... and MPU_RGD*n*.Word3. The MPU hardware automatically clears the valid bit on any writes to words {0,1,2} of the descriptor. Writes to this word set/clear the valid bit in a normal manner.

Because it is also expected that system software may adjust the access controls within a region descriptor (MPU_RGD*n*.Word2) only as different tasks execute, an alternate programming view of this 32-bit entity is provided. If only the access controls are being updated, this operation must be performed by writing to MPU_RGDAAC*n* (alternate access control *n*) as stores to these locations do not affect the descriptor’s valid bit.

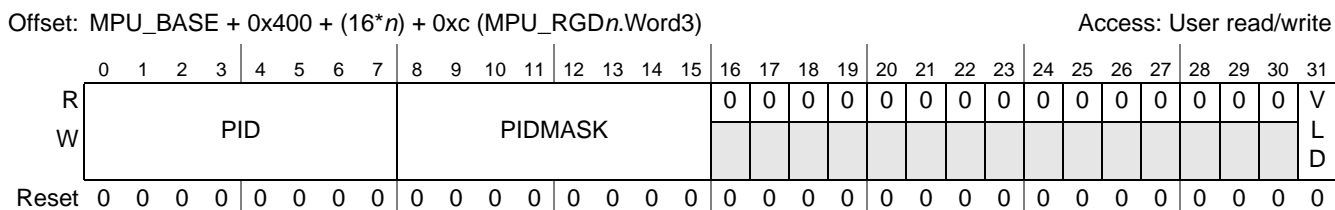

Figure 16-8. MPU Region Descriptor, Word 3 Register (MPU_RGD*n*.Word3)

Table 16-9. MPU_RGD Word 3 Description

| Field | Description |
|-----------------|---|
| 0–7 PID | Process Identifier. This 8-bit field specifies that the optional process identifier is to be included in the determination of whether the current access hits in the region descriptor. This field is combined with the PIDMASK and included in the region hit determination if MPU_RGD <i>n</i> .Word2[MxPE] is set. |
| 8–15 PIDMASK | Process Identifier Mask. This 8-bit field provides a masking capability so that multiple process identifiers can be included as part of the region hit determination. If a bit in the PIDMASK is set, the corresponding bit of the PID is ignored in the comparison. This field is combined with the PID and included in the region hit determination if MPU_RGD <i>n</i> .Word2[MxPE] is set. For more information on the handling of the PID and PIDMASK, see Section 16.3.1.1, Access Evaluation—Hit Determination . |
| 16–30 | Reserved |
| 31 VLD | Valid. This bit signals the region descriptor is valid. Any write to MPU_RGD <i>n</i> .Word{0,1,2} clears this bit, but a write to MPU_RGD <i>n</i> .Word3 sets or clears this bit depending on bit 31 of the write operand. 0 Region descriptor is invalid 1 Region descriptor is valid |

16.2.2.5 MPU Region Descriptor Alternate Access Control n (MPU_RGDAAC n)

As noted in Section 16.2.2.4.3, MPU Region Descriptor n , Word 2 (MPU_RGD n .Word2), it is expected that because system software may adjust the access controls within a region descriptor (MPU_RGD n .Word2) only as different tasks execute, an alternate programming view of this 32-bit entity is desired. If only the access controls are being updated, this operation should be performed by writing to MPU_RGDAAC n (alternate access control n) as stores to these locations do not affect the descriptor's valid bit.

The memory address therefore provides an alternate location for updating MPU_RGD n .Word2.

Address: MPU_BASE + 0x800 + (4* n) (MPU_RGDAAC n)

Access: User read/write

| | | | | | | | | | | | | | | | | |
|-------------|----|----|------|------|------|------|------|------|----|----|------|------|------|----|----|----|
| | 0 | 1 | 2 | 3 | 4 | 5 | 6 | 7 | 8 | 9 | 10 | 11 | 12 | 13 | 14 | 15 |
| R | 0 | 0 | M6RE | M6WE | M5RE | M5WE | M4RE | M4WE | 0 | 0 | 0 | 0 | 0 | 0 | 0 | 0 |
| W | | | | | | | | | | | | | | | | |
| Reset (n=0) | 0 | 0 | 0 | 0 | 0 | 0 | 0 | 0 | 0 | 1 | 1 | 0 | 0 | 0 | 0 | 1 |
| Reset (n>0) | 0 | 0 | 0 | 0 | 0 | 0 | 0 | 0 | 0 | 0 | 0 | 0 | 0 | 0 | 0 | 0 |
| | 16 | 17 | 18 | 19 | 20 | 21 | 22 | 23 | 24 | 25 | 26 | 27 | 28 | 29 | 30 | 31 |
| R | 0 | 0 | 0 | 0 | 0 | 0 | 0 | 0 | 0 | 0 | MOPE | MOSM | MOUM | | | |
| W | | | | | | | | | | | | | r | w | x | |
| Reset (n=0) | 1 | 0 | 0 | 0 | 0 | 1 | 1 | 0 | 0 | 0 | 0 | 0 | 0 | 0 | 0 | 0 |
| Reset (n>0) | 0 | 0 | 0 | 0 | 0 | 0 | 0 | 0 | 0 | 0 | 0 | 0 | 0 | 0 | 0 | 0 |

Figure 16-9. MPU RGD Alternate Access Control n (MPU_RGDAAC n)

Because the MPU_RGDAAC n register is another memory mapping for MPU_RGD n .Word2, the field definitions shown in Table 16-10 are identical to those presented in Table 16-8.

Table 16-10. MPU_RGDAAC Bit Field Descriptions

| Field | Description |
|-------------------------|---|
| | Note: For future code compatibility, do not change the value of reserved bits from their reset value |
| 0–1 | Reserved |
| 2 4 6 M n RE | Bus Master ID n Read Enable. If set, this flag allows bus master ID n to perform read operations. If cleared, any attempted read by bus master ID n terminates with an access error and the read is not performed. Note: See Table 16-1 for the MPU Master ID list. |
| 3 5 7 M n WE | Bus Master n Write Enable. If set, this flag allows bus master n to perform write operations. If cleared, any attempted write by bus master n terminates with an access error and the write is not performed. Note: See Table 16-1 for the MPU Master ID list. |
| 8–25 | Reserved |

Table 16-10. MPU_RGDAAC Bit Field Descriptions (continued)

| Field | Description |
|---------------|---|
| 26 MOPE | Bus Master 0 Process Identifier Enable. If set, this flag specifies that the process identifier and mask (defined in MPU_RGDN.Word3) are to be included in the region hit evaluation. If cleared, then the region hit evaluation does not include the process identifier. |
| 27–28 MOSM | Bus Master 0 Supervisor Mode Access Control. This 2-bit field defines the access controls for bus master 0 when operating in supervisor mode. The MOSM field is defined as: 00 r, w, x = read, write and execute allowed 01 r, -, x = read and execute allowed, but no write 10 r, w, - = read and write allowed, but no execute 11 Same access controls as that defined by MOUM for user mode Note: See Table 16-1 for the MPU Master ID list. |
| 29–31 MOUM | Bus Master 0 User Mode Access Control. This 3-bit field defines the access controls for bus master 0 when operating in user mode. The MOUM field consists of three independent bits, enabling read, write, and execute permissions: {r, w, x}. If set, the bit allows the given access type to occur; if cleared, an attempted access of that mode may be terminated with an access error (if not allowed by any other descriptor) and the access not performed. Note: See Table 16-1 for the MPU Master ID list. |

16.3 Functional Description

In this section, the functional operation of the MPU is detailed. In particular, subsequent sections discuss the operation of the access evaluation macro as well as the handling of error-terminated AHB bus cycles.

16.3.1 Access Evaluation

As discussed, the basic operation of the MPU is performed in the access evaluation macro, a hardware structure replicated in the two-dimensional connection matrix. The access evaluation macro inputs the AHB system bus address and the contents of a region descriptor (RGDN) and performs two major functions: region hit determination and detection of an access protection violation.

16.3.1.1 Access Evaluation—Hit Determination

To determine if the current AHB reference hits in the given region, two magnitude comparators are used with the region’s start and end addresses. There are no hardware checks to verify that the region end address is greater than or equal to the region start address. The software must properly load appropriate values into these fields of the region descriptor.

In addition to the comparison of the AHB reference address versus the region descriptor’s start and end addresses, the optional process identifier is examined against the region descriptor’s PID and PIDMASK fields. For AHB bus masters that do not output a process identifier, the MPU forces the PID term to be asserted.

16.3.1.2 Access Evaluation—Privilege Violation Determination

While the access evaluation macro is making the region hit determination, the logic is also evaluating if the current access is allowed by the permissions defined in the region descriptor. Using the AHB supervisor/user mode signals, a set of permissions is generated from the appropriate fields in the region descriptor. The protection violation logic evaluates the access against the effective permissions.

The access evaluation macro then uses the hit and permission signals to determine if the current access is allowed and the MPU_EDR n (error detail register) is updated in the event of an error.

16.3.2 AHB Error Terminations

For each AHB slave port being monitored, the MPU tests any access for permission violations as above. If a violation occurs, the MPU terminates the bus cycle and reports a protection error for three conditions:

1. If the access does not hit in any region descriptor, a protection error is reported.
2. If the access hits in a single region descriptor and that region signals a protection violation, a protection error is reported.
3. If the access hits in multiple (overlapping) regions and all regions signal protection violations, then a protection error is reported.

The third condition reflects that priority is given to permission granting over access denying for overlapping regions as this approach provides more flexibility to system software in region descriptor assignments. For an example of the use of overlapping region descriptors, see [Section 16.5, Application Information](#).

When the MPU causes a termination error to occur, the effect on the system depends on the bus master requesting the access. If the error was caused by a core access, a machine check is taken. If the error was caused by an eDMA access, an eDMA source or destination error occurs in the eDMA controller, which can be enabled to provide an interrupt request through the INTC. If the error was caused by a FlexRay access, a controller host interface (CHI) illegal system memory access error occurs in the FlexRay controller, which can be enabled to provide an interrupt request to the INTC.

16.4 Initialization Information

The reset state of MPU_CESR[VLD] disables the entire module. While the MPU is disabled, all accesses from all bus masters are allowed. This state also minimizes the power dissipation of the MPU. The power dissipation of each access evaluation macro is minimized when the associated region descriptor is marked as invalid or when MPU_CESR[VLD] = 0.

Typically the appropriate number of region descriptors (MPU_RGD n) are loaded at system startup, including the setting of the MPU_RGD n .Word3[VLD] bits, before MPU_CESR[VLD] is set, enabling the module. This approach allows all the loaded region descriptors to be enabled simultaneously. Once the MPU is enabled, if a memory reference does not hit in any region descriptor, the attempted access is terminated with an error.

16.5 Application Information

In an application's system, interfacing with the MPU can generally be classified into the following activities:

1. Creation of a new memory region requires loading the appropriate region descriptor into an available register location. When a new descriptor is loaded into a RGD n , it would typically be performed using four 32-bit word writes. As discussed in [Section 16.2.2.4.4, MPU Region Descriptor n, Word 3 \(MPU_RGD \$n\$.Word3\)](#), the hardware assists in the maintenance of the valid

bit, so if this approach is followed, there are no coherency issues associated with the multi-cycle descriptor writes. Deletion/removal of an existing memory region is performed by clearing MPU_RGD_n.Word3[VLD].

2. If only the access rights for an existing region descriptor need to change, a 32-bit write to the alternate version of the access control word (MPU_RGDAAC_n) would typically be performed. Writes to the region descriptor using this alternate access control location do not affect the valid bit, so there are, by definition, no coherency issues involved with the update. The access rights associated with the memory region switch instantaneously to the new value as the peripheral write completes.
3. If the region's start and end addresses are to be changed, this would typically be performed by writing a minimum of three words of the region descriptor: MPU_RGD_n.Word{0,1,3}, where the writes to Word0 and Word1 redefine the start and end addresses respectively and the write to Word3 re-enables the region descriptor valid bit. In many situations, all four words of the region descriptor would be rewritten.
4. Typically, references to the MPU's programming model would be restricted to supervisor mode accesses from a specific processor(s), so a region descriptor would be specifically allocated for this purpose with attempted accesses from other masters or while in user mode terminated with an error.
5. When the MPU detects an access error, the current AHB bus cycle is terminated with an error response and information on the faulting reference captured in the MPU_EAR_n and MPU_EDR_n registers. The error-terminated AHB bus cycle typically initiates some type of error response in the originating bus master. For example, a processor core may respond with a bus error exception, while a data movement bus master may respond with an error interrupt. In any event, the processor can retrieve the captured error address and detail information simply by reading the MPU_E{A,D}R_n registers. Information on which error registers contain captured fault data is signaled by MPU_CESR[SPERR].
6. Finally, consider the use of overlapping region descriptors. Application of overlapping regions can reduce the number of descriptors required for a given set of access controls. In the overlapping memory space, the protection rights of the corresponding region descriptors are logically summed together (the boolean OR operator). In the following example of a dual-core system, there are four bus masters: the two processors (CP0, CP1) and two DMA engines (eDMA, a traditional data movement engine transferring data between RAM and peripherals, and FlexRAY, a second engine transferring data to/from the RAM only). Consider the following region descriptor assignments:

| Region Description | RGD _n | CP0 | CP1 | eDMA | FlexRay | | |
|------------------------|------------------|-----|-----|------|---------|-------|----|
| CP0 Code | 0 | rwX | r-- | -- | -- | Flash | |
| CP1 Code | 1 | r-- | rwX | -- | -- | | |
| CP0 Data & Stack | 2 | rw- | --- | -- | -- | RAM | |
| CP0 -> CP1 Shared Data | | 3 | r-- | r-- | -- | | -- |
| CP1 -> CP0 Shared Data | | | --- | rw- | -- | | -- |
| CP0 Data & Stack | 4 | --- | rw- | -- | -- | | |
| Shared DMA Data | 5 | rw- | rw- | rw | rw | | |

Figure 16-10. Overlapping Region Descriptor Example

| Region Description | RGDn | CP0 | CP1 | eDMA | FlexRay | |
|--------------------|------|-----|-----|------|---------|------------|
| MPU | 6 | rw- | rw- | -- | -- | Peripheral |
| Peripherals | 7 | rw- | rw- | rw | -- | |

Figure 16-10. Overlapping Region Descriptor Example

In this example, there are eight descriptors used to span nine regions in the three main spaces of the system memory map (flash, RAM, and peripheral space). Each region indicates the specific permissions for each of the four bus masters and this definition provides an appropriate set of shared, private and executable memory spaces.

Of particular interest are the two overlapping spaces: region descriptors 2 and 3, and 3 and 4.

The space defined by RGD2 with no overlap is a private data and stack area that provides read/write access to CP0 only. The overlapping space between RGD2 and RGD3 defines a shared data space for passing data from CP0 to CP1 and the access controls are defined by the logical OR of the two region descriptors. Thus, CP0 has $(rw- \mid r--)$ = $(rw-)$ permissions, while CP1 has $(--- \mid r--)$ = $(r--)$ permission in this space. Both DMA engines are excluded from this shared processor data region. The overlapping spaces between RGD3 and RGD4 defines another shared data space, this one for passing data from CP1 to CP0. For this overlapping space, CP0 has $(r-- \mid ---)$ = $(r--)$ permission, while CP1 has $(rw- \mid r--)$ = $(rw-)$ permission. The non-overlapped space of RGD4 defines a private data and stack area for CP1 only.

The space defined by RGD5 is a shared data region, accessible by all four bus masters. Finally, the slave peripheral space mapped onto the peripheral bus is partitioned into two regions: one (RGD6) containing the MPU's programming model accessible only to the two processor cores, and the remaining peripheral region (RGD7) accessible to both processors and the traditional eDMA master.

This example is intended to show one possible application of the capabilities of the memory protection unit in a typical system.

Chapter 17

Error Correction Status Module (ECSM)

17.1 Introduction

The error correction status module (ECSM) provides a set of registers that configure and report ECC errors for the device including accesses to RAM and flash memory. The application may configure the device for the types of memory errors to be reported, and then query a set of read-only status and information registers to identify any errors that have been signaled.

There are two types of ECC errors: correctable and non-correctable. A correctable ECC error is generated when only one bit is wrong in a 64-bit doubleword. In this case, it is corrected automatically by hardware and no flags or other indication is set that the error occurred. A non-correctable ECC error is generated when two or more bits in a 64-bit doubleword are incorrect. Non-correctable ECC errors cause an interrupt, and if enabled, additional error details are available in the ECSM.

Error correction is implemented on 64 bits of data at a time, using eight bits for ECC for every 64-bit doubleword. ECC is checked on reads and calculated on writes per the following:

1. 64 bits containing the desired byte / halfword / word or doubleword in memory is read and ECC checked.
2. If the access is a write, then
 - The new byte / halfword / word / doubleword is merged into the 64 bits.
 - New ECC bits are calculated.
 - The 64 bits and the new ECC bits are written back.

NOTE

To use ECC with SRAM, the SRAM memory must be written to before ECC is enabled.

17.1.1 Features

The ECSM has this major feature:

- Registers for capturing information on memory errors if error-correcting codes (ECC) are implemented.

17.2 Memory Map and Registers

This section provides a detailed description of all ECSM registers.

17.2.1 Module Memory Map

The ECSM memory map is shown in [Table 17-1](#). The address of each register is given as an offset to the ECSM base address. Registers are listed in address order, identified by complete name and mnemonic, and lists the type of accesses allowed.

Table 17-1. ECSM Memory Map

| Offset from ECSM_BASE_ADDR (0xFFFF4_0000) | Register | Bits | Access | Reset Value ¹ | Section/Page |
|---|--|------|--------|--------------------------|---------------------------------|
| 0x0000 | ECSM_PCT—Processor Core Type | 16 | RO | U | 17.2.2.1/17-4 |
| 0x0002 | ECSM_REV—Revision | 16 | RO | U | 17.2.2.2/17-4 |
| 0x0008 | ECSM_IMC—Peripheral On-Platform Module Configuration | 32 | RO | U | 17.2.2.3/17-4 |
| 0x000F | ECSM_MRSR—Misc. Reset Status | 8 | RO | 0x00 | 17.2.2.4/17-4 |
| 0x0010–0x0042 | Reserved | | | | |
| 0x0043 | ECSM_ECR—ECC configuration register | 8 | R/W | 0x00 | 17.2.2.5/17-5 |
| 0x0047 | ECSM_ESR—ECC status register | 8 | R/W | 0x00 | 17.2.2.6/17-6 |
| 0x004A | ECSM_EEGR—ECC error generation register | 16 | R/W | 0x0000 | 17.2.2.7/17-7 |
| 0x0050 | ECSM_FEAR—Flash ECC address register | 32 | RO | U | 17.2.2.8/17-9 |
| 0x0056 | ECSM_FEMR—Flash ECC master register | 8 | RO | 0x0U | 17.2.2.9/17-10 |
| 0x0057 | ECSM_FEAT—Flash ECC attributes register | 8 | RO | U | 17.2.2.10/17-11 |
| 0x0058 | ECSM_FEDRH—Flash ECC data register high | 32 | RO | U | 17.2.2.11/17-11 |
| 0x005C | ECSM_FEDRL—Flash ECC data register low | 32 | RO | U | 17.2.2.11/17-11 |
| 0x0060 | ECSM_REAR—RAM ECC address register | 32 | RO | U | 17.2.2.12/17-12 |
| 0x0065 | ECSM_RESR—RAM ECC syndrome register | 8 | RO | U | 17.2.2.13/17-13 |
| 0x0066 | ECSM_REMR—RAM ECC master register | 8 | RO | 0x0U | 17.2.2.14/17-15 |
| 0x0067 | ECSM_REAT—RAM ECC attributes register | 8 | RO | U | 17.2.2.15/17-15 |
| 0x0068 | ECSM_REDRL—RAM ECC data register high | 32 | RO | U | 17.2.2.16/17-16 |
| 0x006C | ECSM_REDRL—RAM ECC data register low | 32 | RO | U | 17.2.2.16/17-16 |
| 0x0007–0x3FFF | Reserved | | | | |

¹ Please refer to the register definition. U = undefined at reset.

Table 17-2. ECSM Graphical Memory Map

| ECSM Offset | Register | | | |
|---------------|---|------------------------------|---|---|
| 0x0000 | Processor Core Type (ECSM_PCT) | | Revision (ECSM_REV) | |
| 0x0008 | IPS Module Configuration (ECSM_IMC) | | | |
| 0x000C | Reserved | | | Misc Reset Status (ECSM_MRSR) |
| 0x0010–0x003F | Reserved | | | |
| 0x0040 | Reserved | | | ECC configuration (ECSM_ECR) |
| 0x0044 | Reserved | | | ECC status register (ECSM_ESR) |
| 0x000048 | Reserved | | ECC error generation register (ECSM_EEGR) | |
| 0x004C | Reserved | | | |
| 0x0050 | Flash ECC address register (ECSM_FEAR) | | | |
| 0x0054 | Reserved | | Flash ECC master register (ECSM_FEMR) | Flash ECC attributes register (ECSM_FEAT) |
| 0x0058 | Flash ECC Data Register High (ECSM_FEDRH) | | | |
| 0x005C | Flash ECC Data Register Low (ECSM_FEDRL) | | | |
| 0x0060 | RAM ECC address register (ECSM_REAR) | | | |
| 0x0064 | Reserved | RAM ECC Syndrome (ECSM_RESR) | RAM ECC Master (ECSM_REMR) | RAM ECC Attributes (ECSM_REAT) |
| 0x0068 | RAM ECC Data Register High (ECSM_REDRH) | | | |
| 0x006C | RAM ECC Data Register Low (ECSM_REDRL) | | | |

17.2.2 Register Descriptions

This section lists the ECSM registers in address order and describes the registers and their bit fields. Attempted accesses to reserved addresses result in an error termination; however, attempted writes to read-only registers are ignored and do not terminate with an error.

NOTE

Unless noted otherwise, reads and writes to the programming model must match the size of the register, e.g., an n -bit register only supports n -bit writes, etc. Attempted writes of a different size than the register width produce an error termination of the bus cycle and no change to the targeted register.

17.2.2.1 Processor Core Type (ECSM_PCT)

The ECSM_PCT is a 16-bit read-only register specifying the architecture of the processor core in the device. The state of this register is defined by a module input signal; it can only be read from the peripheral programming model. Any attempted write is ignored.

17.2.2.2 Revision (ECSM_REV)

The ECSM_REV[0:15] field defines a software-visible revision number.

The ECSM_REV is a 16-bit read-only register specifying a revision number. The state of this register is defined by an input signal; it can only be read from the peripheral programming model. Any attempted write is ignored.

17.2.2.3 Peripheral Module Configuration (ECSM_IMC)

The ECSM_IMC is a 32-bit read-only register identifying the presence/absence of the 32 low-order peripheral modules connected to the primary slave bus controller. The state of this register is defined by a module input signal; it can only be read from the peripheral programming model. Any attempted write is ignored.

A ‘0’ indicates a peripheral module connection to decoded slot “n” is absent. A ‘1’ indicates a peripheral module connection to decoded slot “n” is present.

17.2.2.4 Miscellaneous Reset Status Register (ECSM_MRSR)

The ECSM_MRSR contains a bit for each of the reset sources to the device. An asserted bit indicates the last type of reset that occurred. Only one bit is set at any time in the ECSM_MRSR, reflecting the cause of the most recent reset as signalled by device reset input signals. The ECSM_MRSR can only be read from the peripheral programming model. Any attempted write is ignored.

Address: ECSM Base + 0x000F

Access: User read/write

| | | | | | | | | |
|-------|-----|-----|------|---|---|---|---|---|
| | 0 | 1 | 2 | 3 | 4 | 5 | 6 | 7 |
| R | POR | DIR | SWTR | 0 | 0 | 0 | 0 | 0 |
| W | | | | | | | | |
| Reset | 0 | 0 | 0 | 0 | 0 | 0 | 0 | 0 |

Figure 17-1. Miscellaneous Reset Status Register (ECSM_MRSR)

Table 17-3. Miscellaneous Reset Status Register (ECSM_MRSR) Field Descriptions

| Field | Description |
|----------|---|
| 0 POR | Power-on Reset 1 Last recorded event was caused by a power-on reset (based on a device input signal) |
| 1 DIR | Device-input Reset 1 Last recorded event was a reset caused by a device input reset. |

Table 17-3. Miscellaneous Reset Status Register (ECSM_MRSR) Field Descriptions (continued)

| Field | Description |
|-----------|---|
| 2 SWTR | Platform Software Watchdog Timer Reset 1 Last recorded event was a reset caused by the platform's software watchdog timer. |
| 3–7 | Reserved |

17.2.2.5 ECC Configuration Register (ECSM_ECR)

The ECC configuration register is an 8-bit control register for specifying which types of memory errors are reported. In all systems with ECC, the occurrence of a non-correctable error causes the current access to be terminated with an error condition. In many cases, this error termination is reported directly by the initiating bus master. However, there are certain situations where the occurrence of this type of non-correctable error is not reported by the master. Examples include speculative instruction fetches that are discarded due to a change-of-flow operation and buffered operand writes. The ECC reporting logic in the ECSM provides an optional error interrupt mechanism to signal all non-correctable memory errors. In addition to the interrupt generation, the ECSM captures specific information (memory address, attributes and data, bus master number, etc.) that may be useful for subsequent failure analysis.

See [Figure 17-2](#) and [Table 17-4](#) for the ECC configuration register definition.

Offset: ECSM_BASE_ADDR + 0x0043

Access: User read/write

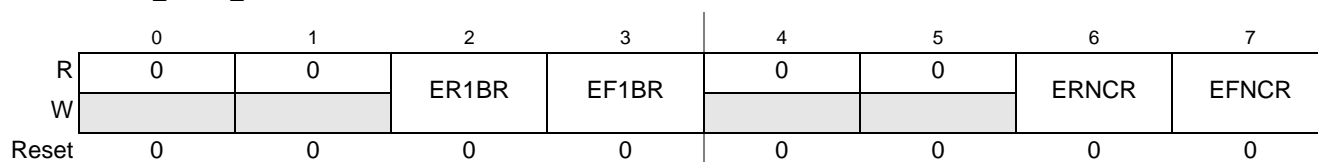
Figure 17-2. ECC Configuration (ECSM_ECR) Register
Table 17-4. ECSM_ECR Field Descriptions

| Field | Description |
|------------|--|
| 0–1 | Reserved |
| 2 ER1BR | Enable RAM 1-bit reporting. 0 Reporting of single-bit RAM corrections is disabled. 1 Reporting of single-bit RAM corrections is enabled. The occurrence of a single-bit RAM correction generates an ECSM ECC interrupt request as signalled by the assertion of ECSM_ESR[R1BC]. The address, attributes and data are also captured in the ECSM_REAR, ECSM_RESR, ECSM_REMR, ECSM_REAT and ECSM_REDR registers. |
| 3 EF1BR | Enable flash 1-bit reporting. 0 Reporting of single-bit flash corrections is disabled. 1 Reporting of single-bit flash corrections is enabled. The occurrence of a single-bit flash correction generates a MCM ECC interrupt request as signalled by the assertion of ECSM_ESR[F1BC]. The address, attributes and data are also captured in the ECSM_FEAR, ECSM_FEMR, ECSM_FEAT and ECSM_FEDR registers. |
| 4–5 | Reserved |

Table 17-4. ECSM_ECR Field Descriptions (continued)

| Field | Description |
|------------|---|
| 6 ERNCR | Enable RAM Non-Correctable Reporting. The occurrence of a non-correctable multi-bit RAM error generates an ECSM ECC interrupt request as signaled by the assertion of ECSM_ESR[RNCE]. The faulting address, attributes, and data in either the 512 KB or 80 KB array are also captured in the ECSM_REAR, ECSM_RESR, ECSM_REMR, ECSM_REAT, and ECSM_REDR registers. 0 Reporting of non-correctable RAM errors is disabled. 1 Reporting of non-correctable RAM errors is enabled. |
| 7 EFNCR | Enable Flash Non-Correctable Reporting. The occurrence of a non-correctable multi-bit flash error generates an ECSM ECC interrupt request as signaled by the assertion of ECSM_ESR[FNCE]. The faulting address, attributes, and data are also captured in the ECSM_FEAR, ECSM_FEMR, ECSM_FEAT, and ECSM_FEDR registers. 0 Reporting of non-correctable flash errors is disabled. 1 Reporting of non-correctable flash errors is enabled. |

17.2.2.6 ECC Status Register (ECSM_ESR)

The ECC status register is an 8-bit control register for signaling which types of properly-enabled ECC events have been detected. The ECSM_ESR signals the last properly-enabled memory event to be detected. An ECC interrupt request is asserted if any flag bit is asserted and its corresponding enable bit is asserted.

The ECSM allows a maximum of one bit of the ECSM_ESR to be asserted at any given time. This preserves the association between the ECSM_ESR and the corresponding address and attribute registers, which are loaded on each occurrence of an properly-enabled ECC event. If there is a pending ECC interrupt and another properly-enabled ECC event occurs, the ECSM hardware automatically handles the ECSM_ESR reporting, clearing the previous data and loading the new state and thus guaranteeing that only a single flag is asserted.

To maintain the coherent software view of the reported event, the following sequence in the ECSM error interrupt service routine is suggested:

1. Read the ECSM_ESR and save it.
2. Read and save all the address and attribute reporting registers.
3. Re-read the ECSM_ESR and verify the current contents matches the original contents. If the two values are different, repeat from step one.
4. When the values are identical, write a 1 to the asserted ECSM_ESR flag to negate the interrupt request.

See [Figure 17-3](#) and [Table 17-5](#) for the ECC status register definition.

Offset: ECSM_BASE_ADDR + 0x0047

Access: User read/write

| | 0 | 1 | 2 | 3 | 4 | 5 | 6 | 7 |
|-------|---|---|------|------|---|---|------|------|
| R | 0 | 0 | R1BC | F1BC | 0 | 0 | RNCE | FNCE |
| W | | | w1c | w1c | | | w1c | w1c |
| Reset | 0 | 0 | 0 | 0 | 0 | 0 | 0 | 0 |

Figure 17-3. ECC Status (ECSM_ESR) Register

Table 17-5. ECSM_ESR Field Descriptions

| Field | Description |
|-----------|---|
| 0–1 | Reserved |
| 2 R1BC | <p>RAM 1-bit Correction. This bit can only be set if ECSM_ECR[EPR1BR] is asserted. The occurrence of a properly-enabled single-bit RAM correction generates an ECSM ECC interrupt request. The address, attributes and data are also captured in the ECSM_REAR, ECSM_RESR, ECSM_REMR, ECSM_REAT and ECSM_REDR registers. To clear this interrupt flag, write a 1 to this bit. Writing a 0 has no effect</p> <p>0 No reportable single-bit RAM correction has been detected. 1 A reportable single-bit RAM correction has been detected.</p> |
| 3 F1BC | <p>Flash 1-bit Correction. This bit can only be set if ECSM_ECR[EPF1BR] is asserted. The occurrence of a properly-enabled single-bit flash correction generates an ECSM ECC interrupt request. The address, attributes and data are also captured in the ECSM_FEAR, ECSM_FEMR, ECSM_FEAT and ECSM_FEDR registers. To clear this interrupt flag, write a 1 to this bit. Writing a 0 has no effect.</p> <p>0 No reportable single-bit flash correction has been detected. 1 A reportable single-bit flash correction has been detected.</p> |
| 4–5 | Reserved |
| 6 RNCE | <p>RAM Non-Correctable Error. The occurrence of a properly-enabled non-correctable RAM error generates an ECSM ECC interrupt request. The faulting address, attributes, and data in either the 512K or 80K array are also captured in the ECSM_REAR, ECSM_RESR, ECSM_REMR, ECSM_REAT, and ECSM_REDR registers. To clear this interrupt flag, write a 1 to this bit. Writing a 0 has no effect.</p> <p>0 No reportable non-correctable RAM error has been detected. 1 A reportable non-correctable RAM error has been detected.</p> |
| 7 FNCE | <p>Flash Non-Correctable Error. The occurrence of a properly-enabled non-correctable flash error generates an ECSM ECC interrupt request. The faulting address, attributes and data are also captured in the ECSM_FEAR, ECSM_FEMR, ECSM_FEAT, and ECSM_FEDR registers. To clear this interrupt flag, write a 1 to this bit. Writing a 0 has no effect.</p> <p>0 No reportable non-correctable flash error has been detected. 1 A reportable non-correctable flash error has been detected.</p> |

If both a flash and RAM non-correctable error occur at the same time, the ECSM records the event with the highest priority, RNCE, and finally FNCE. If both a 512K and 80K RAM non-correctable error occur at the same time, the ECSM records the event with the 512K array.

17.2.2.7 ECC Error Generation Register (ECSM_EEGR)

The ECC error generation register is a 16-bit control register used to force the generation of single- and double-bit data inversions in the memories with ECC, most notably the RAM. This capability is provided for two purposes:

- It provides a software-controlled mechanism for injecting errors into the memories during data writes to verify the integrity of the ECC logic.
- It provides a mechanism to allow testing of the software service routines associated with memory error logging.

The intent is to generate errors during data write cycles, such that subsequent reads of the corrupted address locations generate ECC events, either single-bit corrections or double-bit noncorrectable errors that are terminated with an error response.

Error Correction Status Module (ECSM)

See [Figure 17-4](#) and [Table 17-6](#) for the ECC error generation register definition.

Offset: ECSM_BASE_ADDR + 0x004A

Access: User read/write

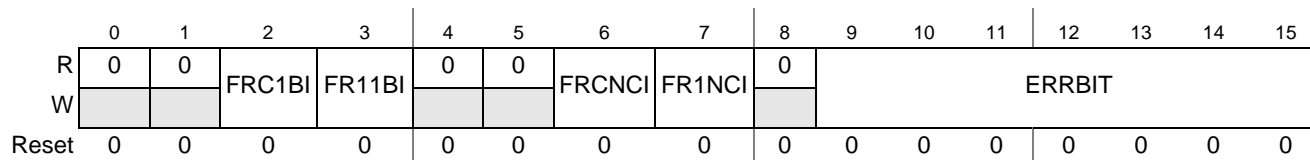

Figure 17-4. ECC Error Generation (ECSM_EEGR) Register

Table 17-6. ECSM_EEGR Field Descriptions

| Field | Description |
|-------------|---|
| 0–1 | Reserved |
| 2 FRC1BI | <p>Force RAM Continuous 1-Bit Data Inversions. The assertion of this bit forces the RAM controller to create 1-bit data inversions, as defined by the bit position specified in ERRBIT, continuously on every write operation.</p> <p>The normal ECC generation takes place in the RAM controller, but then the polarity of the bit position defined by ERRBIT is inverted to introduce a 1-bit ECC event in the RAM.</p> <p>After this bit has been enabled to generate another continuous 1-bit data inversion, it must be cleared before being set again to properly re-enable the error generation logic.</p> <p>0 No RAM continuous 1-bit data inversions are generated. 1 1-bit data inversions in the RAM are continuously generated.</p> |
| 3 FR11BI | <p>Force RAM One 1-bit Data Inversion. The assertion of this bit forces the RAM controller to create one 1-bit data inversion, as defined by the bit position specified in ERRBIT, on the first write operation after this bit is set.</p> <p>The normal ECC generation takes place in the RAM controller, but then the polarity of the bit position defined by ERRBIT is inverted to introduce a 1-bit ECC event in the RAM.</p> <p>After this bit has been enabled to generate a single 1-bit data inversion, it must be cleared before being set again to properly re-enable the error generation logic.</p> <p>0 No RAM single 1-bit data inversion is generated. 1 One 1-bit data inversion in the RAM is generated.</p> |
| 4–5 | Reserved |
| 6 FRCNCI | <p>Force RAM Continuous Noncorrectable Data Inversions. The assertion of this bit forces the RAM controller to create 2-bit data inversions, as defined by the bit position specified in ERRBIT and the overall odd parity bit, continuously on every write operation.</p> <p>After this bit has been enabled to generate another continuous noncorrectable data inversion, it must be cleared before being set again to properly re-enable the error generation logic.</p> <p>The normal ECC generation takes place in the RAM controller, but then the polarity of the bit position defined by ERRBIT and the overall odd parity bit are inverted to introduce a 2-bit ECC error in the RAM.</p> <p>0 No RAM continuous 2-bit data inversions are generated. 1 2-bit data inversions in the RAM are continuously generated.</p> |

Table 17-6. ECSM_EEGR Field Descriptions (continued)

| Field | Description |
|----------------|---|
| 7 FR1NC | <p>Force RAM One Noncorrectable Data Inversions. The assertion of this bit forces the RAM controller to create one 2-bit data inversion, as defined by the bit position specified in ERRBIT and the overall odd parity bit, on the first write operation after this bit is set.</p> <p>The normal ECC generation takes place in the RAM controller, but then the polarity of the bit position defined by ERRBIT and the overall odd parity bit are inverted to introduce a 2-bit ECC error in the RAM.</p> <p>After this bit has been enabled to generate a single 2-bit error, it must be cleared before being set again to properly re-enable the error generation logic.</p> <p>0 No RAM single 2-bit data inversions are generated. 1 One 2-bit data inversion in the RAM is generated.</p> |
| 8 | Reserved |
| 9–15 ERRBIT | <p>Error Bit Position. The vector defines the bit position, which is complemented to create the data inversion on the write operation. For the creation of 2-bit data inversions, the bit specified by this field plus the odd parity bit of the ECC code are inverted.</p> <p>The platform RAM controller follows a vector bit ordering scheme where LSB = 0. Errors in the ECC syndrome bits can be generated by setting this field to a value greater than the RAM width. For example, consider a 64-bit RAM implementation.</p> <p>The 64-bit ECC approach requires 8 code bits for a 64-bit double word. For PRAM data width of 64 bits, the actual SRAM 64b data + 8b for ECC = 72 bits. The following association between the ERRBIT field and the corrupted memory bit is defined:</p> <pre> if ERRBIT = 0, then RAM[0] is inverted if ERRBIT = 1, then RAM[1] is inverted ... if ERRBIT = 63, then RAM[63] is inverted if ERRBIT = 64, then ECC Parity[0] is inverted if ERRBIT = 65, then ECC Parity[1] is inverted ... if ERRBIT = 71, then ECC Parity[7] is inverted </pre> |

NOTE

If an attempt to force a non-correctable inversion by asserting ECSM_EEGR[FRCNCI] or ECSM_EEGR[FRC1NCI], and ECSM_EEGR[ERRBIT] equals 64, no data inversion is generated.

The only allowable values for the 4 control bit enables {FR11BI, FRC1BI, FRCNCI, FR1NCI} are {0,0,0,0}, {1,0,0,0}, {0,1,0,0}, {0,0,1,0} and {0,0,0,1}. All other values result in undefined behavior.

17.2.2.8 Flash ECC Address Register (ECSM_FEAR)

The ECSM_FEAR is a 32-bit register for capturing the address of the last, properly-enabled ECC event in the flash memory. Depending on the state of the ECC configuration register, an ECC event in the flash causes the address, attributes and data associated with the access to be loaded into the ECSM_FEAR, ECSM_FEMR, ECSM_FEAT, and ECSM_FEDR registers and also the appropriate flag (F1BC or FNCE) in the ECC status register to be asserted.

Error Correction Status Module (ECSM)

This register is read-only; any attempted write is ignored. See [Figure 17-5](#) and [Table 17-7](#) for the flash ECC address register definition.

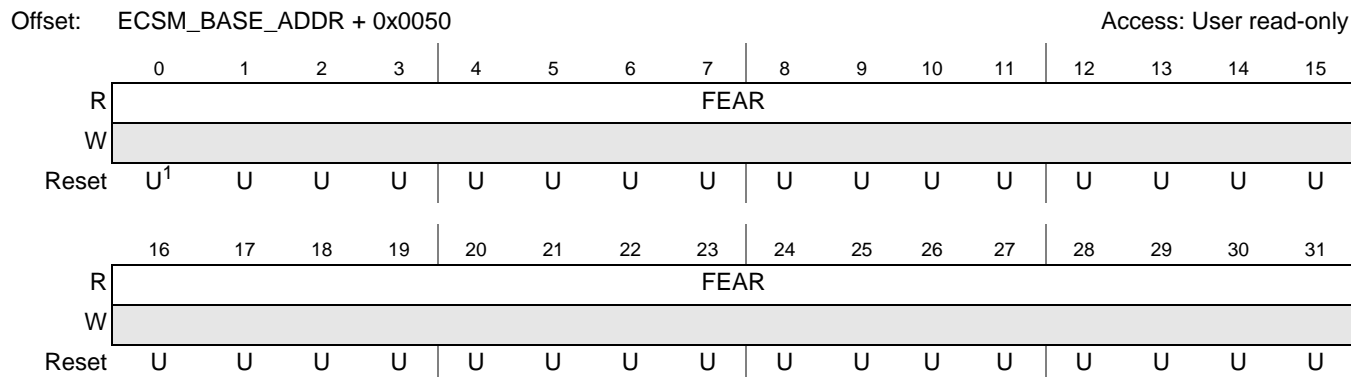

Figure 17-5. Flash ECC Address (ECSM_FEAR) Register

¹ U = undefined at reset

Table 17-7. ECSM_FEAR Field Descriptions

| Field | Description |
|--------------|---|
| 0–15 FEAR | Flash ECC Address Register. Contains the faulting access address of the last, properly enabled flash ECC event. |

17.2.2.9 Flash ECC Master Number Register (ECSM_FEMR)

The ECSM_FEMR is an 8-bit register for capturing the XBAR bus master number of the last, properly-enabled ECC event in the flash memory. Depending on the state of the ECC Configuration Register, an ECC event in the flash causes the address, attributes and data associated with the access to be loaded into the ECSM_FEAR, ECSM_FEMR, ECSM_FEAT, and ECSM_FEDR registers and also the appropriate flag (FNCE) in the ECC status register to be asserted.

This register is read-only; any attempted write is ignored. See [Figure 17-6](#) and [Table 17-8](#) for the flash ECC master number register definition.

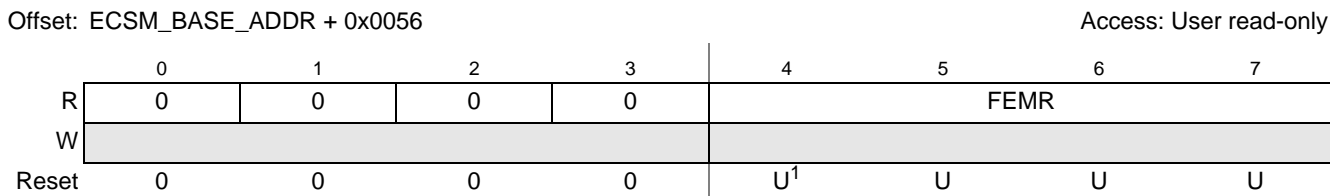

Figure 17-6. Flash ECC Master Number (ECSM_FEMR) Register

¹ U = undefined at reset

Table 17-8. ECSM_FEMR Field Descriptions

| Field | Description |
|-------------|--|
| 0–7 FEMR | Flash CC Master Number Register. Contains the XBAR bus master number of the faulting access of the last, properly enabled flash ECC event. |

17.2.2.10 Flash ECC Attributes Register (ECSM_FEAT)

The ECSM_FEAT is an 8-bit register for capturing the XBAR bus master attributes of the last, properly-enabled ECC event in the flash memory. Depending on the state of the ECC Configuration Register, an ECC event in the flash causes the address, attributes and data associated with the access to be loaded into the ECSM_FEAR, ECSM_FEMR, ECSM_FEAT, and ECSM_FEDR registers and also the appropriate flag (FNCE) in the ECC status register to be asserted.

This register is read-only; any attempted write is ignored. See [Figure 17-7](#) and [Table 17-9](#) for the flash ECC attributes register definition.

Offset: ECSM_BASE_ADDR + 0x0057

Access: User read-only

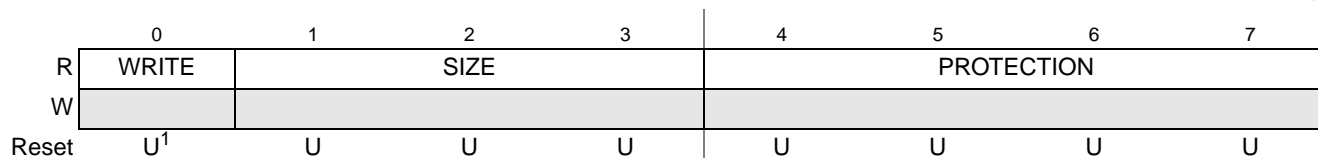

Figure 17-7. Flash ECC Attributes (ECSM_FEAT) Register

¹ U = undefined at reset

Table 17-9. ECSM_FEAT Field Descriptions

| Field | Description |
|-------------------|--|
| 0 WRITE | 0 Read access. 1 Write access. |
| 1–3 SIZE | 000 8-bit access 001 16-bit access 010 32-bit access 011 64-bit access 1xx Reserved |
| 4–7 PROTECTION | Cache: 0xxx Non-cacheable 1xxx Cacheable Buffer: x0xx Non-bufferable x1xx Bufferable Mode: xx0x User mode xx1x Supervisor mode Type: xxx0 I-Fetch xxx1 Data |

17.2.2.11 Flash ECC Data Register (ECSM_FEDR)

The ECSM_FEDR is a 64-bit register for capturing the data associated with the last properly enabled ECC event in the flash memory. Depending on the state of the ECC configuration register, an ECC event in the flash causes the address, attributes and data associated with the access to be loaded into the ECSM_FEAR, ECSM_FEMR, ECSM_FEAT, and ECSM_FEDR registers and also the appropriate flag (F1BC or FNCE) in the ECC status register to be asserted.

Error Correction Status Module (ECSM)

The data captured on a multi-bit non-correctable ECC error is undefined.

This register is read-only; any attempted write is ignored. See [Figure 17-9](#) and [Table 17-10](#) for the flash ECC data register definition.

Offset: ECSM_BASE_ADDR + 0x0058

Access: User read-only

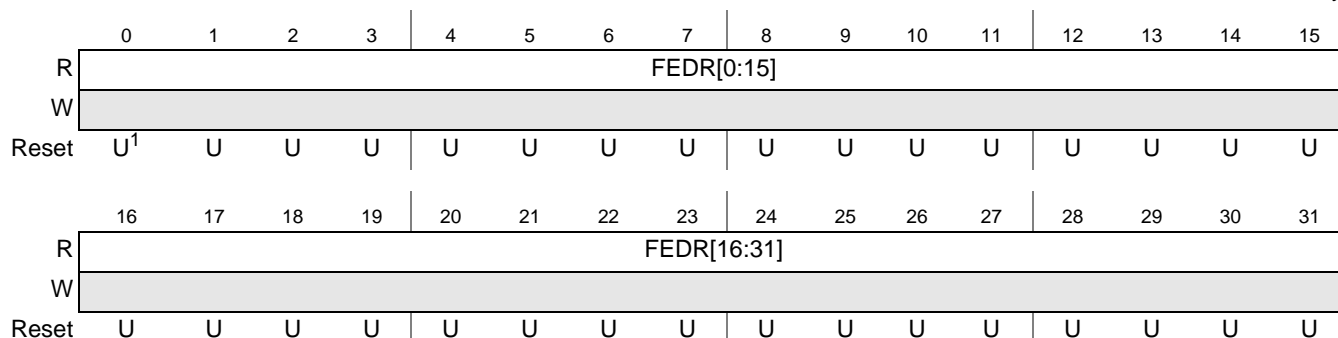

Figure 17-8. Flash ECC Data High (ECSM_FEDRH) Register

¹ U = undefined at reset

Offset: ECSM_BASE_ADDR + 0x005C

Access: User read-only

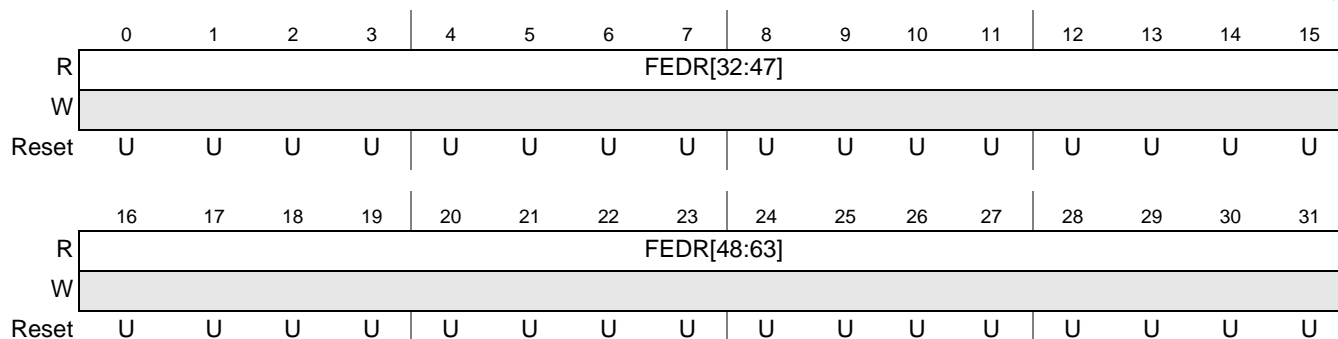

Figure 17-9. Flash ECC Data Low (ECSM_FEDRL) Register

Table 17-10. PECSM_FEDR Field Descriptions

| Field | Description |
|--------------|--|
| 0–63 FEDR | Flash ECC Data Register. Contains the data associated with the faulting access of the last properly enabled flash ECC event. The register contains the data value taken directly from the platform data bus. |

17.2.2.12 RAM ECC Address Register (ECSM_REAR)

The ECSM_REAR is a 32-bit register for capturing the address of the last, properly-enabled ECC event in the RAM memory. Depending on the state of the ECC configuration register, an ECC event in the RAM causes the address, attributes and data associated with the access to be loaded into the ECSM_REAR, ECSM_RESR, ECSM_REMR, ECSM_REAT, and ECSM_REDR registers and also the appropriate flag (RNCE) in the ECC status register to be asserted.

This register is read-only; any attempted write is ignored. See [Figure 17-10](#) and [Table 17-11](#) for the RAM ECC address register definition.

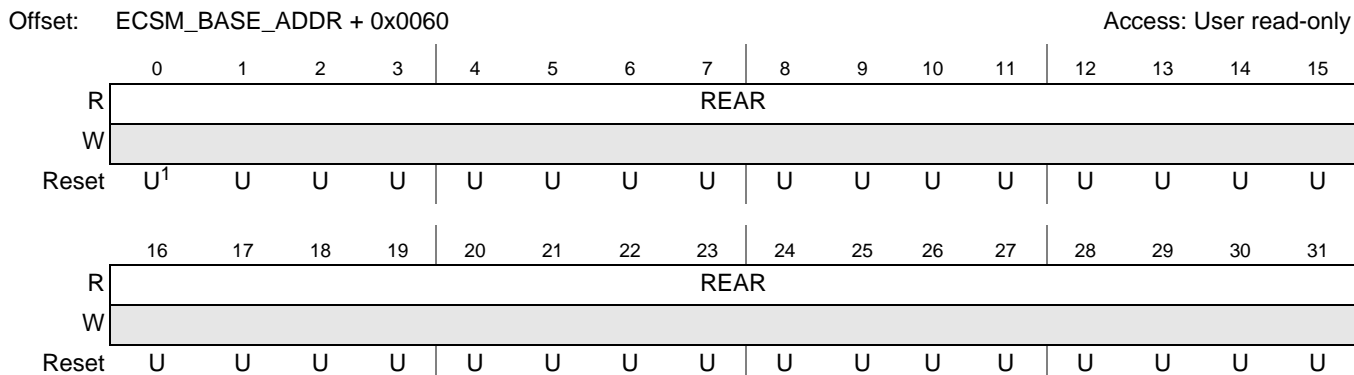

Figure 17-10. RAM ECC Address (ECSM_REAR) Register

¹ U = undefined at reset

Table 17-11. ECSM_REAR Field Descriptions

| Field | Description |
|--------------|---|
| 0–31 REAR | RAM ECC Address Register. Contains the faulting access address of the last, properly-enabled RAM ECC event. |

17.2.2.13 RAM ECC Syndrome Register (ECSM_RESR)

The ECSM_RESR is an 8-bit register for capturing the error syndrome of the last properly enabled ECC event in the RAM memory. Depending on the state of the ECC configuration register, an ECC event in the RAM causes the address, attributes, and data associated with the access to be loaded into the ECSM_REAR, ECSM_RESR, ECSM_REMR, ECSM_REAT and ECSM_REDR registers, and the appropriate flag (RIBC or RNCE) in the ECC status register to be asserted.

This register is read-only; any attempted write is ignored. See [Figure 17-11](#) and [Table 17-12](#) for the RAM ECC syndrome register definition.

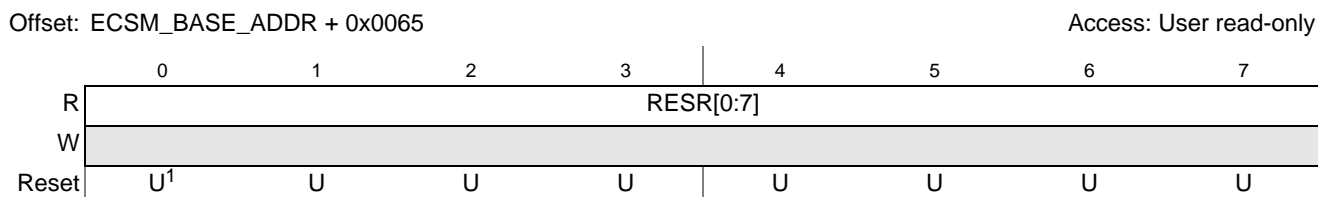

Figure 17-11. RAM ECC Syndrome (ECSM_RESR) Register

¹ U = undefined at reset

Table 17-12. PECSM_RESR Field Descriptions

| Field | Description |
|----------|--|
| 0–7 RESR | RAM ECC Syndrome Register. This 8-bit syndrome field includes 7 bits of Hamming decoded parity plus an odd-parity bit for the entire 72-bit (64-bit data + 8 ECC) code word. The upper 7 bits of the syndrome specify the exact bit position in error for single-bit correctable codewords, and the combination of a non-zero 7-bit syndrome plus overall incorrect parity bit signal a multi-bit, non-correctable error. For correctable single-bit errors, the mapping shown in associates the upper 7 bits of the syndrome with the data bit in error. |

Table 17-13.

| ECSM_RESR[0:7] | Data Bit in Error | ECSM_RESR[0:7] | Data Bit in Error | ECSM_RESR[0:7] | Data Bit in Error |
|----------------|-------------------|----------------|-------------------|----------------|-------------------|
| 0x00 | No Error | 0x4F | DATA[32] | 0xA4 | DATA[41] |
| 0x01 | ECC[0] | 0x52 | DATA[34] | 0xA7 | DATA[42] |
| 0x02 | ECC[1] | 0x54 | DATA[35] | 0xA8 | DATA[43] |
| 0x04 | ECC[2] | 0x57 | DATA[36] | 0xAB | DATA[44] |
| 0x08 | ECC[3] | 0x58 | DATA[37] | 0xAD | DATA[45] |
| 0x0B | DATA[17] | 0x5B | DATA[38] | 0xB0 | DATA[46] |
| 0x0E | DATA[16] | 0x5D | DATA[39] | 0xB5 | DATA[47] |
| 0x10 | ECC[4] | 0x62 | DATA[56] | 0xCB | DATA[1] |
| 0x13 | DATA[18] | 0x64 | DATA[57] | 0xCE | DATA[0] |
| 0x15 | DATA[19] | 0x67 | DATA[58] | 0xD3 | DATA[2] |
| 0x16 | DATA[20] | 0x68 | DATA[59] | 0xD5 | DATA[3] |
| 0x19 | DATA[21] | 0x6B | DATA[60] | 0xD6 | DATA[4] |
| 0x1A | DATA[22] | 0x6D | DATA[61] | 0xD9 | DATA[5] |
| 0x1C | DATA[23] | 0x70 | DATA[62] | 0xDA | DATA[6] |
| 0x20 | ECC[5] | 0x75 | DATA[63] | 0xDC | DATA[7] |
| 0x23 | DATA[8] | 0x80 | ECC[7] | 0xE3 | DATA[24] |
| 0x25 | DATA[9] | 0x8A | DATA[49] | 0xE5 | DATA[25] |
| 0x26 | DATA[10] | 0x8F | DATA[48] | 0xE6 | DATA[26] |
| 0x29 | DATA[11] | 0x92 | DATA[50] | 0xE9 | DATA[27] |
| 0x2A | DATA[12] | 0x94 | DATA[51] | 0xEA | DATA[28] |
| 0x2C | DATA[13] | 0x97 | DATA[52] | 0xEC | DATA[29] |
| 0x31 | DATA[14] | 0x98 | DATA[53] | 0xF1 | DATA[30] |
| 0x34 | DATA[15] | 0x9B | DATA[54] | 0xF4 | DATA[31] |
| 0x40 | ECC[6] | 0x9D | DATA[55] | Others | Multiple |
| 0x4A | DATA[33] | 0xA2 | DATA[40] | | |

17.2.2.14 RAM ECC Master Number Register (ECSM_REMR)

The ECSM_REMR is an 8-bit register for capturing the XBAR bus master number of the last, properly-enabled ECC event in the RAM memory. Depending on the state of the ECC configuration register, an ECC event in the RAM causes the address, attributes, and data associated with the access to be loaded into the ECSM_REAR, ECSM_RESR, ECSM_REMR, ECSM_REAT, and ECSM_REDR registers and also the appropriate flag (RNCE) in the ECC status register to be asserted.

This register is read-only; any attempted write is ignored. See [Figure 17-12](#) and [Table 17-14](#) for the RAM ECC master number register definition.

Offset: ECSM_BASE_ADDR + 0x0066

Access: User read-only

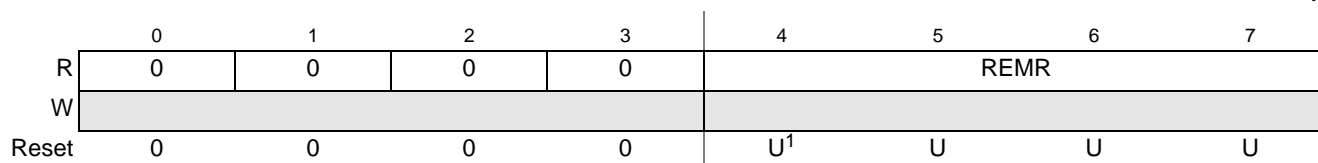

Figure 17-12. RAM ECC Master Number (ECSM_REMR) Register

¹ U = undefined at reset

Table 17-14. ECSM_REMR Field Descriptions

| Field | Description |
|-------------|---|
| 0–7 REMR | RAM ECC Master Number Register. Contains the XBAR bus master number of the faulting access of the last, properly-enabled RAM ECC event. |

17.2.2.15 RAM ECC Attributes Register (ECSM_REAT)

The ECSM_REAT is an 8-bit register for capturing the XBAR bus master attributes of the last properly enabled ECC event in the RAM memory. Depending on the state of the ECC configuration register, an ECC event in the RAM causes the address, attributes, and data associated with the access to be loaded into the ECSM_REAR, ECSM_RESR, ECSM_REMR, ECSM_REAT, and ECSM_REDR registers and also the appropriate flag (RNCE) in the ECC status register to be asserted.

This register is read-only; any attempted write is ignored. See [Figure 17-13](#) and [Table 17-15](#) for the RAM ECC attributes register definition.

Offset: ECSM_BASE_ADDR + 0x0067

Access: User read-only

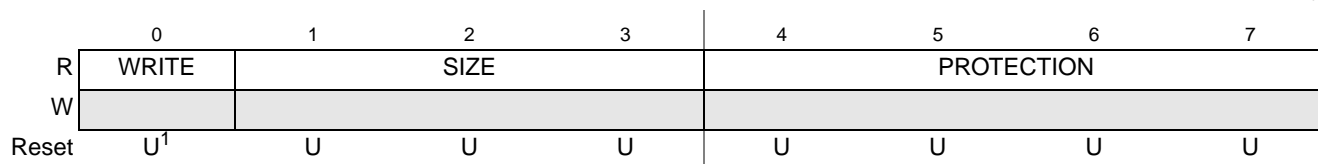

Figure 17-13. RAM ECC Attributes (ECSM_REAT) Register

¹ U = undefined at reset

Table 17-15. ECSM_REAT Field Descriptions

| Field | Description |
|-------------------|--|
| 0 WRITE | 0 Read access. 1 Write access. |
| 1–3 SIZE | 000 8-bit access. 001 16-bit access. 010 32-bit access. 011 64-bit access. 1xx Reserved. |
| 4–7 PROTECTION | Cache: 0xxx Non-cacheable. 1xxx Cacheable. Buffer: x0xx Non-bufferable. x1xx Bufferable. Mode: xx0x User mode. xx1x Supervisor mode. Type: xxx0 I-Fetch. xxx1 Data. |

17.2.2.16 RAM ECC Data Register (ECSM_REDR)

The ECSM_REDR is a 64-bit register for capturing the data associated with the last properly enabled ECC event in the RAM memory. Depending on the state of the ECC configuration register, an ECC event in the RAM causes the address, attributes, and data associated with the access to be loaded into the ECSM_REAR, ECSM_RESR, ECSM_REMR, ECSM_REAT, and ECSM_REDR registers and also the appropriate flag (RIBC or RNCE) in the ECC status register to be asserted.

The data captured on a multi-bit non-correctable ECC error is undefined. This register is read-only; any attempted write is ignored. See [Figure 17-15](#) and [Table 17-16](#) for the RAM ECC data register definition.

Offset: ECSM_BASE_ADDR + 0x0068

Access: User read-only

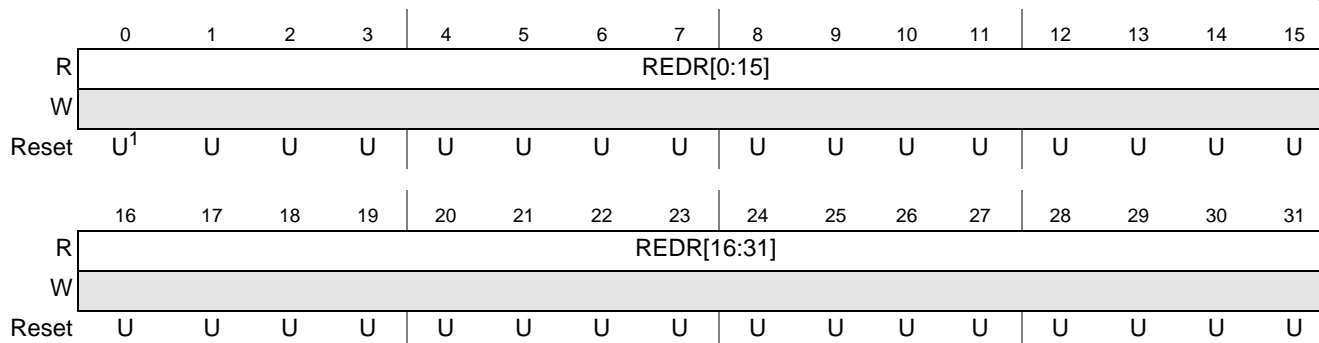

Figure 17-14. RAM ECC Data High (ECSM_REDRH) Register

¹ U = undefined at reset

Offset: ECSM_BASE_ADDR + 0x006C

Access: User read-only

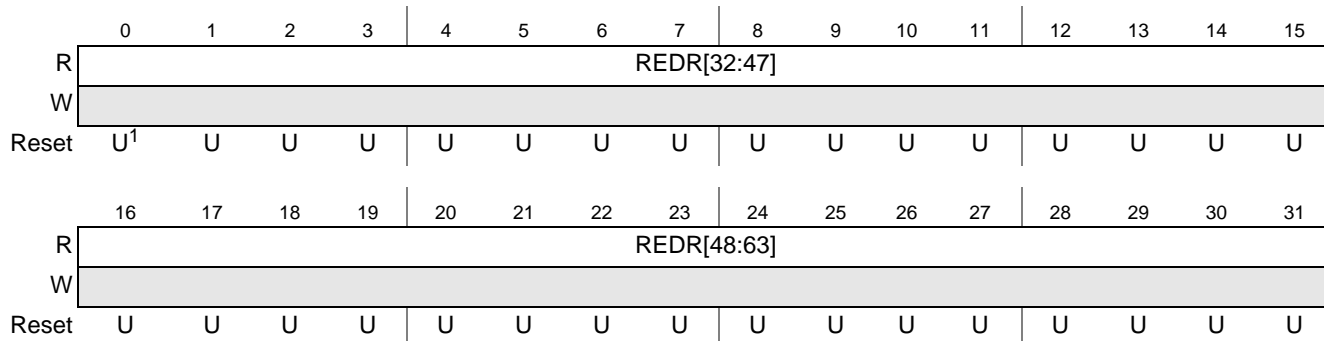

Figure 17-15. RAM ECC Data Low (ECSM_REDRL) Register

¹ U = undefined at reset

Table 17-16. REDR Field Descriptions

| Field | Description |
|--------------|---|
| 0–63 REDR | RAM ECC Data Register. Contains the data associated with the faulting access of the last properly enabled platform RAM ECC event. The register contains the data value taken directly from the platform data bus. |



Chapter 18

Software Watchdog Timer (SWT)

18.1 Introduction

18.1.1 Overview

The Software Watchdog Timer (SWT) is a peripheral module that can prevent system lockup in situations such as software getting trapped in a loop or if a bus transaction fails to terminate. When enabled, the SWT require periodic execution of a watchdog servicing operation. The servicing operation resets the timer to a specified time-out period. If this servicing action does not occur before the timer expires the SWT generates an interrupt or hardware reset. The SWT can be configured to generate a reset or interrupt on an initial time-out; a reset is always generated on a second consecutive time-out.

The SWT interrupt is ‘ORed’ with the critical interrupt signal from the SIU and routed to the critical interrupt inputs of the CPU; see the SIU chapter for details.

The SWT includes an interrupt status bit so the ISR software can determine if the critical interrupt request came from the SWT or the external critical interrupt pin (WKPCFG_GPIO213).

The SWT can assert a reset when the watchdog timer expires. This reset will cause a system reset equivalent to assertion of the RESET pin. Bit 6 of the Reset Status Register in the SIU indicates the SWT as the source of the last reset.

18.1.2 Features

The SWT has the following features:

- 32-bit time-out register to set the time-out period
- Programmable selection of system or oscillator clock for timer operation
- Programmable selection of window mode or regular servicing
- Programmable selection of reset or interrupt on an initial time-out
- Programmable selection of fixed or keyed servicing
- Master access protection
- Hard and soft configuration lock bits

18.1.3 Modes of Operation

The SWT supports three device modes of operation: normal, debug and stop. When the SWT is enabled in normal mode, its counter runs continuously. In debug mode, operation of the counter is controlled by the FRZ bit in the SWT_MCR. If the FRZ bit is set, the counter is stopped in debug mode, otherwise it

continues to run. In stop mode, operation of the counter is controlled by the STP bit in the SWT_MCR. If the STP bit is set, the counter is stopped in stop mode, otherwise it continues to run.

18.2 External Signal Description

The SWT module does not have any external interface signals.

18.3 Memory Map and Register Definition

The SWT programming model has seven 32-bit registers. The programming model can only be accessed using 32-bit (word) accesses. References using a different size are invalid. Other types of invalid accesses include: writes to read only registers, incorrect values written to the service register when enabled, accesses to reserved addresses and accesses by masters without permission. If the RIA bit in the SWT_MCR is set then the SWT generates a system reset on an invalid access otherwise a bus error is generated. If either the HLK or SLK bits in the SWT_MCR are set then the SWT_MCR, SWT_TO, SWT_WN, SWT_SK registers are read only.

18.3.1 Memory Map

The SWT memory map are shown in [Table 18-1](#). The base address for each SWT is given in [Table 18-1](#).

Table 18-1. SWT Memory Map

| Address Offset | Register | Bits | Access | Reset Value | Section/Page |
|----------------|-------------------------------------|------|------------------|-------------|----------------------------|
| 0x0000 | SWT_MCR—SWT Module Control Register | 32 | R/W | 0xFF00_0*0B | 18.3.2.1/2 |
| 0x0004 | SWT_IR—SWT Interrupt Register | 32 | R/W | 0x0000_0000 | 18.3.2.2/5 |
| 0x0008 | SWT_TO—SWT Time-out Register | 32 | R/W | 0x0005_FCD0 | 18.3.2.3/5 |
| 0x000C | SWT_WN—SWT Window Register | 32 | R/W | 0x0000_0000 | 18.3.2.4/6 |
| 0x0010 | SWT_SR—SWT Service Register | 32 | R/W | 0x0000_0000 | 18.3.2.5/6 |
| 0x0014 | SWT_CO—SWT Counter Output Register | 32 | R | 0x0000_0000 | 18.3.2.6/7 |
| 0x0018 | SWT_SK—SWT Service Key Register | 32 | R/W ¹ | 0x0000_0000 | 18.3.2.7/8 |
| 0x001C–0x3FFF | Reserved | | | | |

NOTES:

¹ If neither HLK or SLK lock bit in the SWT_MCR is set, the SWT_SK can be initialized by software to a non-zero value.

18.3.2 Register Descriptions

The following sections detail the individual registers within the SWT programming model.

18.3.2.1 SWT Control Register (SWT_MCR)

The SWT_MCR contains fields for configuring and controlling the SWT. This register is read only if either the SWT_MCR[HLK] or SWT_MCR[SLK] bits are set.

Offset 0x0000

Access: Read/Write

| | | | | | | | | | | | | | | | | |
|-------|-----|-----|---|---|-----|-----|-----|-----|---|---|----|----|----|----|----|----|
| | 0 | 1 | 2 | 3 | 4 | 5 | 6 | 7 | 8 | 9 | 10 | 11 | 12 | 13 | 14 | 15 |
| R | MAP | MAP | 0 | 0 | MAP | MAP | MAP | MAP | 0 | 0 | 0 | 0 | 0 | 0 | 0 | 0 |
| W | 0 | 1 | | | 4 | 5 | 6 | 7 | | | | | | | | |
| Reset | 1 | 1 | 1 | 1 | 1 | 1 | 1 | 1 | 0 | 0 | 0 | 0 | 0 | 0 | 0 | 0 |

| | | | | | | | | | | | | | | | | |
|-------|----|----|----|----|----|----|-----|-----|-----|-----|-----|-----|-----|-----|-----|-----|
| | 16 | 17 | 18 | 19 | 20 | 21 | 22 | 23 | 24 | 25 | 26 | 27 | 28 | 29 | 30 | 31 |
| R | 0 | 0 | 0 | 0 | 0 | 0 | KEY | RIA | WND | ITR | HLK | SLK | CSL | STP | FRZ | WEN |
| W | | | | | | | | | | | | | | | | |
| Reset | 0 | 0 | 0 | 0 | 0 | 0 | * | 1 | 0 | 0 | 0 | 0 | 1 | 0 | 1 | 1 |

Figure 18-1. SWT Control Register (SWT_MCR)

Table 18-2. SWT_MCR Field Descriptions

| Field | Description |
|--------------------------------|---|
| 0–1 4–7 MAP _n | Master Access Protection for Master n 0 = Access for the master is not enabled 1 = Access for the master is enabled Master IDs are listed in Table 14-1 . Once set, MAP _n bit is cleared only by other masters that are not disabled, or only after the reset. |
| 2–3 8–21 | Reserved |
| 22 KEY | Keyed Service Mode. 0 = Fixed Service Sequence, the fixed sequence 0xA602, 0xB480 is used to service the watchdog 1 = Keyed Service Mode, two pseudorandom key values are used to service the watchdog |
| 23 RIA | Reset on Invalid Access. 0 = Invalid access to the SWT generates a bus error 1 = Invalid access to the SWT causes a system reset if WEN=1 (watchdog enabled) |
| 24 WND | Window Mode. 0 = Regular mode, service sequence can be done at any time 1 = Windowed mode, the service sequence is only valid when the down counter is less than the value in the SWT_WN register. |
| 25 ITR | Interrupt Then Reset. 0 = Generate a reset on a time-out 1 = Generate an interrupt on an initial time-out, reset on a second consecutive time-out |
| 26 HLK | Hard Lock. This bit is only cleared at reset. 0 = SWT_MCR, SWT_TO, SWT_WN and SWT_SK are read/write registers if SLK=0 1 = SWT_MCR, SWT_TO, SWT_WN and SWT_SK are read only registers |
| 27 SLK | Soft Lock. This bit is cleared by writing the unlock sequence to the service register. 0 = SWT_MCR, SWT_TO, SWT_WN and SWT_SK are read/write registers if HLK=0 1 = SWT_MCR, SWT_TO, SWT_WN and SWT_SK are read only registers |

Software Watchdog Timer (SWT)

| Field | Description |
|-----------|--|
| 28 CSL | Clock Selection. Selects the clock that drives the internal timer. 0 = System clock. 1 = Oscillator clock. |
| 29 STP | Stop Mode Control. Allows the watchdog timer to be stopped when the device enters stop mode. 0 = SWT counter continues to run in stop mode 1 = SWT counter is stopped in stop mode |
| 30 FRZ | Debug Mode Control. Allows the watchdog timer to be stopped when the device enters debug mode. 0 = SWT counter continues to run in debug mode 1 = SWT counter is stopped in debug mode |
| 31 WEN | Watchdog Enabled. 0 = SWT is disabled 1 = SWT is enabled |

18.3.2.2 SWT Interrupt Register (SWT_IR)

The SWT_IR contains the time-out interrupt flag.

Offset 0x0004

Access: Read/Write

| | | | | | | | | | | | | | | | | |
|-------|---|---|---|---|---|---|---|---|---|---|----|----|----|----|----|----|
| | 0 | 1 | 2 | 3 | 4 | 5 | 6 | 7 | 8 | 9 | 10 | 11 | 12 | 13 | 14 | 15 |
| R | 0 | 0 | 0 | 0 | 0 | 0 | 0 | 0 | 0 | 0 | 0 | 0 | 0 | 0 | 0 | 0 |
| W | | | | | | | | | | | | | | | | |
| Reset | 0 | 0 | 0 | 0 | 0 | 0 | 0 | 0 | 0 | 0 | 0 | 0 | 0 | 0 | 0 | 0 |

| | | | | | | | | | | | | | | | | |
|-------|----|----|----|----|----|----|----|----|----|----|----|----|----|----|----|-----|
| | 16 | 17 | 18 | 19 | 20 | 21 | 22 | 23 | 24 | 25 | 26 | 27 | 28 | 29 | 30 | 31 |
| R | 0 | 0 | 0 | 0 | 0 | 0 | 0 | 0 | 0 | 0 | 0 | 0 | 0 | 0 | 0 | TIF |
| W | | | | | | | | | | | | | | | | |
| Reset | 0 | 0 | 0 | 0 | 0 | 0 | 0 | 0 | 0 | 0 | 0 | 0 | 0 | 0 | 0 | 0 |

Figure 18-2. SWT Interrupt Register (SWT_IR)

Table 18-3. SWT_IR Field Descriptions

| Field | Description |
|-----------|--|
| 0–30 | Reserved |
| 31 TIF | Time-out Interrupt Flag. The flag and interrupt are cleared by writing a 1 to this bit. Writing a 0 has no effect. 0 = No interrupt request. 1 = Interrupt request due to an initial time-out. |

18.3.2.3 SWT Time-Out Register (SWT_TO)

The SWT Time-Out (SWT_TO) register contains the 32-bit time-out period. This register is read only if either the SWT_MCR[HLK] or SWT_MCR[SLK] bits are set.

Offset: 0x008

Access: Read/Write

| | | | | | | | | | | | | | | | | | | | | | | | | | | | | | | | | |
|-------|-----|---|---|---|---|---|---|---|---|---|----|----|----|----|----|----|----|----|----|----|----|----|----|----|----|----|----|----|----|----|----|----|
| | 0 | 1 | 2 | 3 | 4 | 5 | 6 | 7 | 8 | 9 | 10 | 11 | 12 | 13 | 14 | 15 | 16 | 17 | 18 | 19 | 20 | 21 | 22 | 23 | 24 | 25 | 26 | 27 | 28 | 29 | 30 | 31 |
| R | WTO | | | | | | | | | | | | | | | | | | | | | | | | | | | | | | | |
| W | | | | | | | | | | | | | | | | | | | | | | | | | | | | | | | | |
| Reset | 0 | 0 | 0 | 0 | 0 | 0 | 0 | 0 | 0 | 0 | 0 | 0 | 0 | 1 | 0 | 1 | 1 | 1 | 1 | 1 | 1 | 1 | 0 | 0 | 1 | 1 | 0 | 1 | 0 | 0 | 0 | 0 |

Figure 18-3. SWT Time-Out Register (SWT_TO)

Table 18-4. SWT_TO Register Field Descriptions

| Field | Description |
|-------------|---|
| 0–31 WTO | Watchdog time-out period in clock cycles. An internal 32-bit down counter is loaded with this value or 0x100 which ever is greater when the service sequence is written or when the SWT is enabled. |

18.3.2.4 SWT Window Register (SWT_WN)

The SWT Window (SWT_WN) register contains the 32-bit window start value. This register is cleared on reset. This register is read only if either the SWT_MCR[HLK] or SWT_MCR[SLK] bits are set.

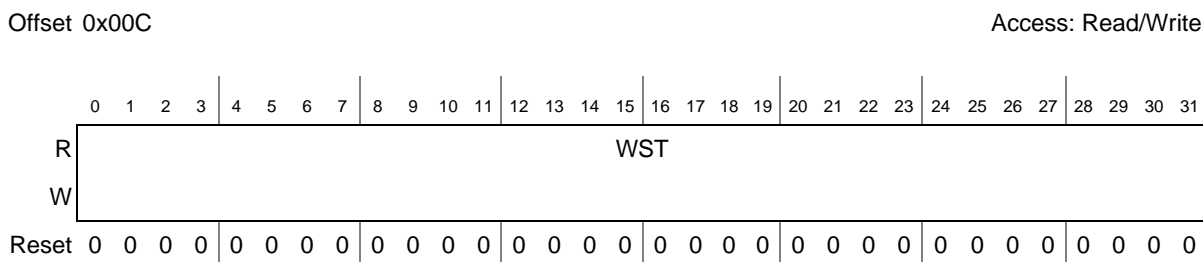

Figure 18-4. SWT Window Register (SWT_WN)

Table 18-5. SWT_WN Register Field Descriptions

| Field | Description |
|-------------|---|
| 0–31 WST | Window start value. When window mode is enabled, the service sequence can only be written when the internal down counter is less than this value. |

18.3.2.5 SWT Service Register (SWT_SR)

The SWT Time-Out (SWT_SR) service register is the target for service operation writes used to reset the watchdog timer.

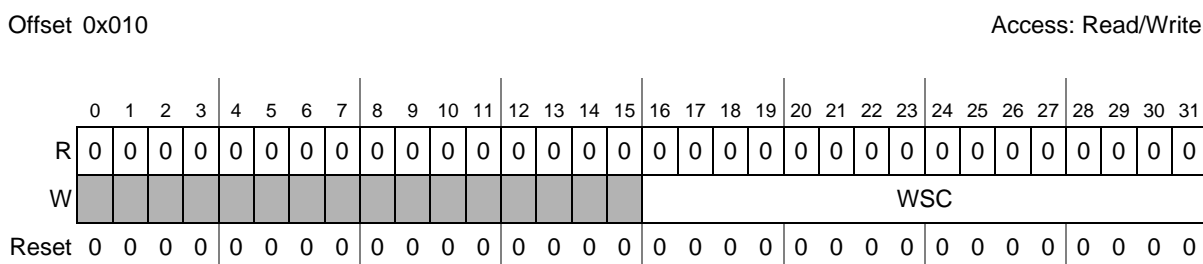

Figure 18-5. SWT Service Register (SWT_SR)

Table 18-6. SWT_SR Field Descriptions

| Field | Description |
|--------------|--|
| 0–15 | Reserved |
| 16–31 WSC | Watchdog Service Code. This field is used to service the watchdog and to clear the soft lock bit (SWT_MCR[SLK]). If the SWT_MCR[KEY] bit is set, two pseudorandom key values are written to service the watchdog, see section Section 18.4, Functional Description , for details. Otherwise, the sequence 0xA602 followed by 0xB480 is written to the WSC field. To clear the soft lock bit (SWT_MCR[SLK]), the value 0xC520 followed by 0xD928 is written to the WSC field. |

18.3.2.6 SWT Counter Output Register (SWT_CO)

The SWT Counter Output (SWT_CO) register is a read only register that shows the value of the internal down counter when the SWT is disabled.

Offset 0x014

Access: Read Only

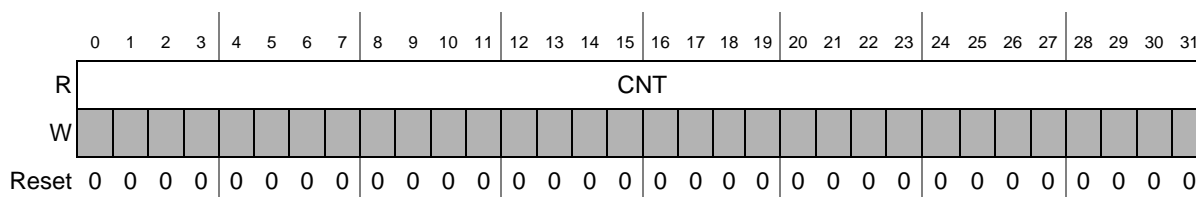
Figure 18-6. SWT Counter Output Register (SWT_CO)
Table 18-7. SWT_CO Register Field Descriptions

| Field | Description |
|-------------|---|
| 0–31 CNT | Watchdog Count. When the watchdog is disabled (SWT_MCR[WEN]=0) this field shows the value of the internal down counter. When the watchdog is enabled the value of this field is 0x0000_0000. Values in this field can lag behind the internal counter value for up to six system plus eight counter clock cycles. Therefore, the value read from this field immediately after disabling the watchdog may be higher than the actual value of the internal counter. |

18.3.2.7 SWT Service Key Register (SWT_SK)

The SWT Service Key (SWT_SK) register holds the previous (or initial) service key value. This register is read only if either the SWT_MCR[HLK] or SWT_MCR[SLK] bits are set.

Offset 0x018

Access: Read/Write

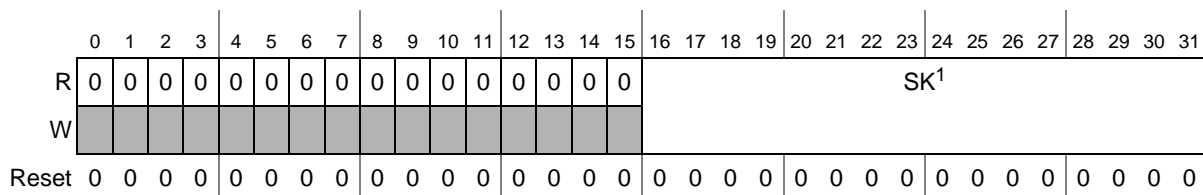

NOTES:

¹ If neither HLK or SLK lock bit in the SWT_MCR is set, the SWT_SK can be initialized by software to a non-zero value.

Figure 18-7. SWT Service Key Register (SWT_SK)

Table 18-8. SWT_SK Field Descriptions

| Field | Description |
|-------------|--|
| 0–15 | Reserved |
| 16–31 SK | Service Key. This field is the previous (or initial) service key value used in keyed service mode. If SWT_MCR[KEY] is set, the next key value to be written to the SWT_SR is $(17*SK+3) \text{ mod } 2^{16}$. |

18.4 Functional Description

The SWT is a 32-bit timer designed to enable the system to recover in situations such as software getting trapped in a loop or if a bus transaction fails to terminate. It includes a control register (SWT_MCR), an interrupt register (SWT_IR), a time-out register (SWT_TO), a window register (SWT_WN), a service register (SWT_SR), a counter output register (SWT_CO) and a service key register (SWT_SK).

The SWT_MCR includes bits to enable the timer, set configuration options and lock configuration of the module. The watchdog is enabled by setting the SWT_MCR[WEN] bit. The watchdog starts operation automatically after reset is released (WEN=1).

The SWT_TO register holds the watchdog time-out period in clock cycles unless the value is less than 0x100 in which case the time-out period is set to 0x100. This time-out period is loaded into an internal 32-bit down counter when the SWT is enabled and each time a valid service operation is performed. The SWT_MCR[CSL] bit selects which clock (system or oscillator) is used to drive the down counter.

The configuration of the SWT can be locked through use of either a soft lock or a hard lock. In either case, when locked the SWT_MCR, SWT_TO, SWT_WN and SWT_SK registers are read only. The hard lock is enabled by setting the SWT_MCR[HCLK] bit which can only be cleared by a reset. The soft lock is enabled by setting the SWT_MCR[SLK] bit and is cleared by writing the unlock sequence to the service register. The unlock sequence is a write of 0xC520 followed by a write of 0xD928 to the SWT_SR[WSC] field. There is no timing requirement between the two writes. The unlock sequence logic ignores service sequence writes and recognizes the 0xC520, 0xD928 sequence regardless of previous writes. The unlock sequence can be written at any time and does not require the SWT_MCR[WEN] bit to be set.

When enabled, the SWT requires periodic execution of a servicing operation which consists of writing two values to the SWT_SR. Writing the proper sequence of values loads the internal down counter with the time-out period. There is no timing requirement between the two writes and the service sequence logic ignores unlock sequence writes. If the SWT_MCR[KEY] bit is zero, the fixed sequence 0xA602, 0xB480 is written to the SWT_SR[WSC] field to service the watchdog. If the SWT_MCR[KEY] bit is set, then two pseudorandom keys are written to the SWT_SR[WSC] field to service the watchdog. The key values are determined by the pseudorandom key generator defined in Figure 18-8. This algorithm will generate a sequence of 2^{16} different key values before repeating. The state of the key generator is held in the SWT_SK register. For example, if SWT_SK[SK] is 0x0100 then the service sequence keys are 0x1103, 0x2136. In this mode, each time a valid key is written to the SWT_SR register, the SWT_SK register is updated. So, after servicing the watchdog by writing 0x1103 and then 0x2136 to the SWT_SR[WSC] field, SWT_SK[SK] is 0x2136 and the next key sequence is 0x3499, 0x7E2C.

$$SK_{n+1} = (17 * SK_n + 3) \bmod 2^{16}$$

Figure 18-8. Pseudorandom Key Generator

Accesses to SWT registers occur with no peripheral bus wait states. (The peripheral bus bridge may add one or more system wait states.) However, due to synchronization logic in the SWT design, recognition of the service sequence or configuration changes may require up to three system plus seven counter clock cycles.

If window mode is enabled (SWT_MCR[WND] bit is set), the service sequence must be performed in the last part of the time-out period defined by the window register. The window is open when the down counter is less than the value in the SWT_WN register. Outside of this window, service sequence writes are invalid accesses and generate a bus error or reset depending on the value of the SWT_MCR[RIA] bit. For example, if the SWT_TO register is set to 5000 and SWT_WN register is set to 1000 then the service sequence must be performed in the last 20% of the time-out period. There is a short lag in the time it takes for the window to open due to synchronization logic in the watchdog design. This delay could be up to three system plus four counter clock cycles.

The interrupt then reset bit (SWT_MCR[ITR]) controls the action taken when a time-out occurs. If the SWT_MCR[ITR] bit is not set, a reset is generated immediately on a time-out. If the SWT_MCR[ITR] bit is set, an initial time-out causes the SWT to generate an interrupt and load the down counter with the time-out period. If the service sequence is not written before the second consecutive time-out, the SWT generates a system reset. The interrupt is indicated by the time-out interrupt flag (SWT_IR[TIF]). The interrupt request is cleared by writing a one to the SWT_IR[TIF] bit. Refer to [Section 27.4.1, External Interrupt Request Sources](#), and [Section 3.2.1.5, DMA/Interrupt Request Enable Register \(SIU_DIRER\)](#), for details on the enabling and routing of the SWT interrupt signals.

The SWT_CO register shows the value of the down counter when the watchdog is disabled. When the watchdog is enabled this register is cleared. The value shown in this register can lag behind the value in the internal counter for up to six system plus eight counter clock cycles.

The SWT_CO can be used during a software self test of the SWT. For example, the SWT can be enabled and not serviced for a fixed period of time less than the time-out value. Then the SWT can be disabled (SWT_MCR[WEN] cleared) and the value of the SWT_CO read to determine if the internal down counter is working properly.

Chapter 19

System Timer Module (STM)

19.1 Introduction

19.1.1 Overview

The System Timer Module (STM) is a 32-bit timer designed to support commonly required system and application software timing functions. The STM includes a 32-bit up counter and four 32-bit compare channels with a separate interrupt source for each channel. The counter is driven by the system clock divided by an 8-bit prescale value (1 to 256).

19.1.2 Features

The STM has the following features:

- One 32-bit up counter with 8-bit prescaler
- Four 32-bit compare channels
 - One channel with a dedicated interrupt node
 - Three channels sharing the same interrupt node
- Independent interrupt source for each channel
- Counter can be stopped in debug mode

19.1.3 Modes of Operation

The STM supports two device modes of operation: normal and debug. When the STM is enabled in normal mode, its counter runs continuously. In debug mode, operation of the counter is controlled by the FRZ bit in the STM_CR register. If the FRZ bit is set, the counter is stopped in debug mode, otherwise it continues to run.

19.2 External Signal Description

The STM does not have any external interface signals.

19.3 Memory Map and Register Definition

The STM programming model has fourteen 32-bit registers. The STM registers can only be accessed using 32-bit (word) accesses. Attempted references using a different size or to a reserved address generates a bus error termination.

19.3.1 Memory Map

The STM memory map is shown in [Table 19-1](#).

Table 19-1. STM Memory Map

| Address Offset | Register | Bits | Access | Reset Value | Section/Page |
|----------------|---|------|--------|-------------|----------------------------|
| 0x0000 | STM_CR—STM Control Register | 32 | R/W | 0x0000_0000 | 19.3.2.1/3 |
| 0x0004 | STM_CNT—STM Counter Register | 32 | R/W | 0x0000_0000 | 19.3.2.2/4 |
| 0x0008 | Reserved | | | | |
| 0x000C | Reserved | | | | |
| 0x0010 | STM_CCR0—STM Channel 0 Control Register | 32 | R/W | 0x0000_0000 | 19.3.2.3/4 |
| 0x0014 | STM_CIR0—STM Channel 0 Interrupt Register | 32 | R/W | 0x0000_0000 | 19.3.2.4/5 |
| 0x0018 | STM_CMP0—STM Channel 0 Compare Register | 32 | R/W | 0x0000_0000 | 19.3.2.5/5 |
| 0x001C | Reserved | | | | |
| 0x0020 | STM_CCR1—STM Channel 1 Control Register | 32 | R/W | 0x0000_0000 | 19.3.2.3/4 |
| 0x0024 | STM_CIR1—STM Channel 1 Interrupt Register | 32 | R/W | 0x0000_0000 | 19.3.2.4/5 |
| 0x0028 | STM_CMP1—STM Channel 1 Compare Register | 32 | R/W | 0x0000_0000 | 19.3.2.5/5 |
| 0x002C | Reserved | | | | |
| 0x0030 | STM_CCR2—STM Channel 2 Control Register | 32 | R/W | 0x0000_0000 | 19.3.2.3/4 |
| 0x0034 | STM_CIR2—STM Channel 2 Interrupt Register | 32 | R/W | 0x0000_0000 | 19.3.2.4/5 |
| 0x0038 | STM_CMP2—STM Channel 2 Compare Register | 32 | R/W | 0x0000_0000 | 19.3.2.5/5 |
| 0x003C | Reserved | | | | |
| 0x0040 | STM_CCR3—STM Channel 3 Control Register | 32 | R/W | 0x0000_0000 | 19.3.2.3/4 |
| 0x0044 | STM_CIR3—STM Channel 3 Interrupt Register | 32 | R/W | 0x0000_0000 | 19.3.2.4/5 |
| 0x0048 | STM_CMP3—STM Channel 3 Compare Register | 32 | R/W | 0x0000_0000 | 19.3.2.5/5 |
| 0x004C -0x3FFF | Reserved | | | | |

19.3.2 Register Descriptions

The following sections detail the individual registers within the STM programming model.

19.3.2.1 STM Control Register (STM_CR)

The STM Control Register (STM_CR) includes the prescale value, freeze control and timer enable bits.

Offset 0x000

Access: Read/Write

| | | | | | | | | | | | | | | | | |
|-------|-----|----|----|----|----|----|----|----|----|----|----|----|----|----|-----|-----|
| | 0 | 1 | 2 | 3 | 4 | 5 | 6 | 7 | 8 | 9 | 10 | 11 | 12 | 13 | 14 | 15 |
| R | 0 | 0 | 0 | 0 | 0 | 0 | 0 | 0 | 0 | 0 | 0 | 0 | 0 | 0 | 0 | 0 |
| W | | | | | | | | | | | | | | | | |
| Reset | 0 | 0 | 0 | 0 | 0 | 0 | 0 | 0 | 0 | 0 | 0 | 0 | 0 | 0 | 0 | 0 |
| | 16 | 17 | 18 | 19 | 20 | 21 | 22 | 23 | 24 | 25 | 26 | 27 | 28 | 29 | 30 | 31 |
| R | CPS | | | | | | | | 0 | 0 | 0 | 0 | 0 | 0 | FRZ | TEN |
| W | | | | | | | | | | | | | | | FRZ | TEN |
| Reset | 0 | 0 | 0 | 0 | 0 | 0 | 0 | 0 | 0 | 0 | 0 | 0 | 0 | 0 | 0 | 0 |

Figure 19-1. STM Control Register (STM_CR)

Table 19-2. STM_CR Field Descriptions

| Field | Description |
|--------------|--|
| 0–15 | Reserved |
| 16–23 CPS | Counter Prescaler. Selects the clock divide value for the prescaler (1 - 256). 0x00 = Divide system clock by 1 0x01 = Divide system clock by 2 ... 0xFF = Divide system clock by 256 |
| 24–29 | Reserved |
| 30 FRZ | Freeze. Allows the timer counter to be stopped when the device enters debug mode. 0 = STM counter continues to run in debug mode. 1 = STM counter is stopped in debug mode. |
| 31 TEN | Timer Counter Enabled. 0 = Counter is disabled. 1 = Counter is enabled. |

19.3.2.2 STM Count Register (STM_CNT)

The STM Count Register (STM_CNT) holds the timer count value.

Offset 0x004

Access: Read/Write

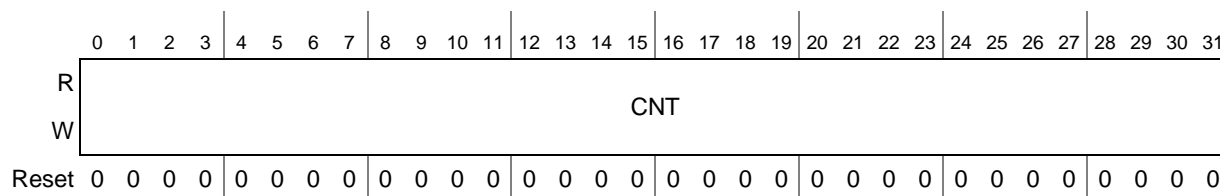

Figure 19-2. STM Count Register (STM_CNT)

Table 19-3. STM_CNT Field Descriptions

| Field | Description |
|-------------|---|
| 0–31 CNT | Timer count value used as the time base for all channels. When enabled, the counter increments at the rate of the system clock divided by the prescale value. |

19.3.2.3 STM Channel Control Register (STM_CCRn)

The STM Channel Control Register (STM_CCRn) has the enable bit for channel n of the timer.

Offset 0x10+0x10*n

Access: Read/Write

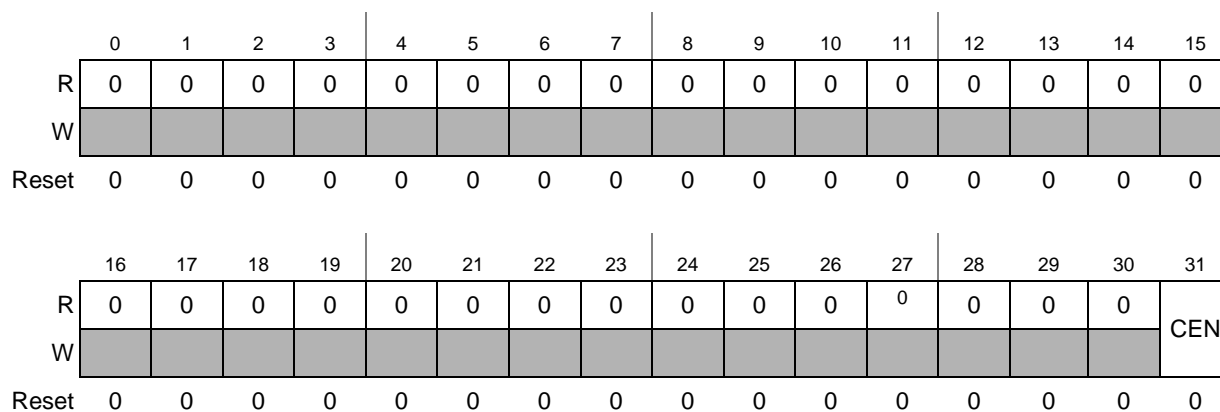

Figure 19-3. STM Channel Control Register (STM_CCRn)

Table 19-4. STM_CCRn Field Descriptions

| Field | Description |
|-----------|--|
| 0–30 | Reserved |
| 31 CEN | Channel Enable. 0 = The channel is disabled. 1 = The channel is enabled. |

19.3.2.4 STM Channel Interrupt Register (STM_CIRn)

The STM Channel Interrupt Register (STM_CIRn) has the interrupt flag for channel n of the timer.

Offset 0x14+0x10*n

Access: Read/Write

| | | | | | | | | | | | | | | | | |
|-------|---|---|---|---|---|---|---|---|---|---|----|----|----|----|----|----|
| | 0 | 1 | 2 | 3 | 4 | 5 | 6 | 7 | 8 | 9 | 10 | 11 | 12 | 13 | 14 | 15 |
| R | 0 | 0 | 0 | 0 | 0 | 0 | 0 | 0 | 0 | 0 | 0 | 0 | 0 | 0 | 0 | 0 |
| W | | | | | | | | | | | | | | | | |
| Reset | 0 | 0 | 0 | 0 | 0 | 0 | 0 | 0 | 0 | 0 | 0 | 0 | 0 | 0 | 0 | 0 |

| | | | | | | | | | | | | | | | | |
|-------|----|----|----|----|----|----|----|----|----|----|----|----|----|----|----|-----|
| | 16 | 17 | 18 | 19 | 20 | 21 | 22 | 23 | 24 | 25 | 26 | 27 | 28 | 29 | 30 | 31 |
| R | 0 | 0 | 0 | 0 | 0 | 0 | 0 | 0 | 0 | 0 | 0 | 0 | 0 | 0 | 0 | CIF |
| W | | | | | | | | | | | | | | | | |
| Reset | 0 | 0 | 0 | 0 | 0 | 0 | 0 | 0 | 0 | 0 | 0 | 0 | 0 | 0 | 0 | 0 |

Figure 19-4. STM Channel Interrupt Register (STM_CIRn)

Table 19-5. STM_CIRn Field Descriptions

| Field | Description |
|-----------|--|
| 0–30 | Reserved |
| 31 CIF | Channel Interrupt Flag. The flag and interrupt are cleared by writing a 1 to this bit. Writing a 0 has no effect. 0 = No interrupt request. 1 = Interrupt request due to a match on the channel. |

19.3.2.5 STM Channel Compare Register (STM_CMPn)

The STM channel compare register (STM_CMPn) holds the compare value for channel n.

Offset 0x18+0x10*n

Access: Read/Write

| | | | | | | | | | | | | | | | | | | | | | | | | | | | | | | | | |
|-------|-----|---|---|---|---|---|---|---|---|---|----|----|----|----|----|----|----|----|----|----|----|----|----|----|----|----|----|----|----|----|----|----|
| | 0 | 1 | 2 | 3 | 4 | 5 | 6 | 7 | 8 | 9 | 10 | 11 | 12 | 13 | 14 | 15 | 16 | 17 | 18 | 19 | 20 | 21 | 22 | 23 | 24 | 25 | 26 | 27 | 28 | 29 | 30 | 31 |
| R | CMP | | | | | | | | | | | | | | | | | | | | | | | | | | | | | | | |
| W | CMP | | | | | | | | | | | | | | | | | | | | | | | | | | | | | | | |
| Reset | 0 | 0 | 0 | 0 | 0 | 0 | 0 | 0 | 0 | 0 | 0 | 0 | 0 | 0 | 0 | 0 | 0 | 0 | 0 | 0 | 0 | 0 | 0 | 0 | 0 | 0 | 0 | 0 | 0 | 0 | 0 | 0 |

Figure 19-5. STM Channel Compare Register (STM_CMPn)

Table 19-6. STM_CMPn Register Field Descriptions

| Field | Description |
|-------------|---|
| 0–31 CMP | Compare value for channel n. If the STM_CCRn[CEN] bit is set and the STM_CMPn register matches the STM_CNT register, a channel interrupt request is generated and the STM_CIRn[CIF] bit is set. |

19.4 Functional Description

The System Timer Module (STM) is a 32-bit timer designed to support commonly required system and application software timing functions. The STM includes a 32-bit up counter and four 32-bit compare channels with a separate interrupt source for each channel.

The STM has one 32-bit up counter (STM_CNT) that is used as the time base for all channels. When enabled, the counter increments at the system clock frequency divided by a prescale value. The STM_CR[CPS] field sets the divider to any value in the range from 1 to 256. The counter is enabled with the STM_CR[TEN] bit. When enabled in normal mode the counter continuously increments. When enabled in debug mode the counter operation is controlled by the STM_CR[FRZ] bit. When the STM_CR[FRZ] bit is set, the counter is stopped in debug mode, otherwise it continues to run in debug mode. The counter rolls over at 0xFFFF_FFFF to 0x0000_0000 with no restrictions at this boundary.

The STM has four identical compare channels. Each channel includes a channel control register (STM_CCRn), a channel interrupt register (STM_CIRn) and a channel compare register (STM_CMPn). The channel is enabled by setting the STM_CCRn[CEN] bit. When enabled, the channel will set the STM_CIR[CIF] bit and generate an interrupt request when the channel compare register matches the timer counter. The interrupt request is cleared by writing a 1 to the STM_CIRn[CIF] bit. A write of 0 to the STM_CIRn[CIF] bit has no effect.

Chapter 20

Periodic Interrupt Timer (PIT_RTI)

20.1 Introduction

20.1.1 Overview

This section describes the function of the Periodic Interrupt Timer block (PIT_RTI). The PIT is an array of timers that can be used to generate interrupts. It also provides a dedicated Real Time Interrupt Timer (RTI), which runs on a separate clock and can be used for system wakeup from low power mode.

20.1.2 Block Diagram

A block diagram of the PIT_RTI module is shown in [Figure 20-1](#).

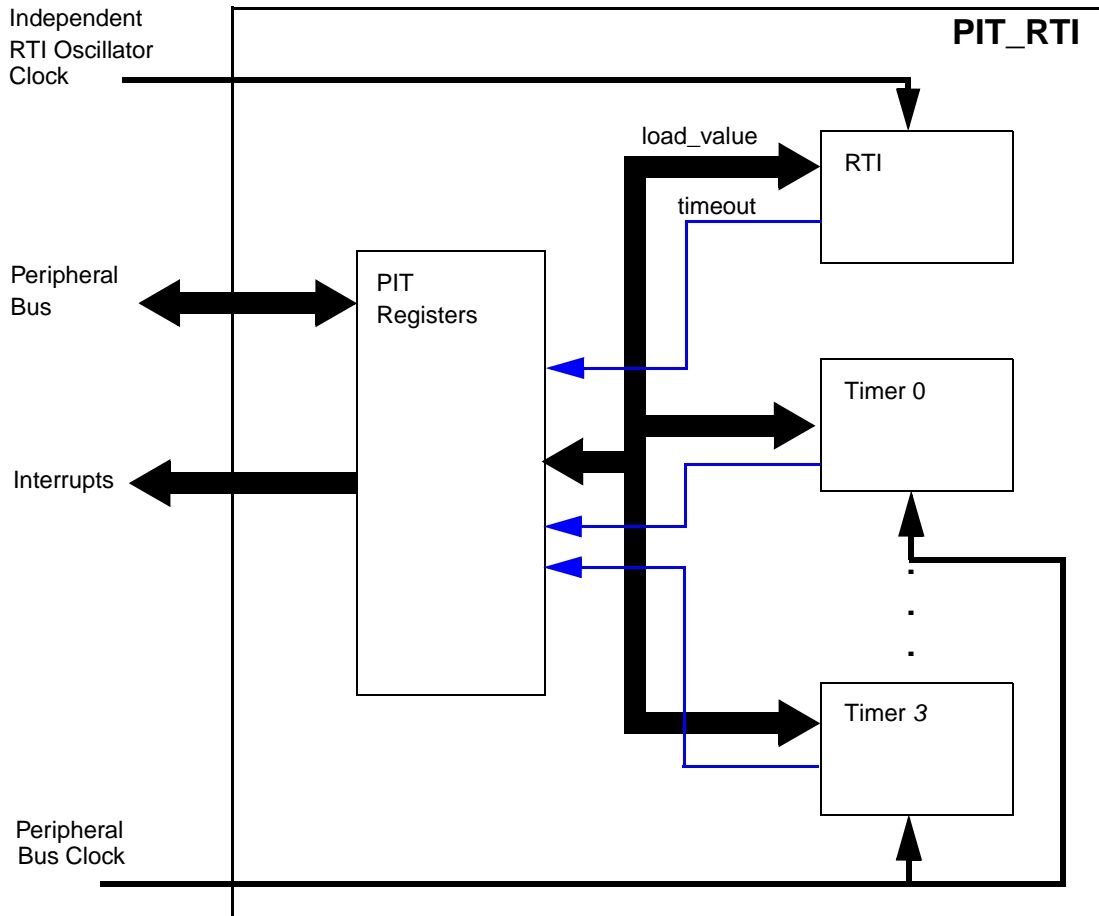

Figure 20-1. Block diagram of PIT_RTI

20.1.3 Features

The main features of this block are:

- Timers can be configured to generate interrupts
- All interrupts are maskable
- Independent timeout periods for each timer and RTI
- RTI can be used to generate a CPU wake-up interrupt
- RTI clock source is the crystal oscillator, no pre-scalars are used
- PIT timer clock source is the peripheral clock, no pre-scalars are used

20.2 Signal Description

The PIT module has no external pins.

20.3 Memory Map and Register Description

This section provides a detailed description of all registers accessible in the PIT_RTI module.

20.3.1 Memory Map

Table 20-1 provides an overview off all PIT_RTI registers.

Table 20-1. PIT_RTI Memory Map

| Base Address Offset (Base = 0xC3FF0000) | Register | Bits | Access | Reset Value | Section/Page |
|--|---|------|--------|-------------|----------------------------|
| 0x000 | PIT_MCR—PIT Module Control Register | 32 | R/W | 0x0000_0000 | 20.3.2.1/4 |
| 0x004—0x0EC | Reserved | | | | |
| 0x0F4 | PIT_RTI_CVAL—RTI current value register | 32 | R | 0x0000_0000 | 20.3.2.3/5 |
| 0x0F8 | PIT_RTI_TCTRL—RTI timer control register | 32 | R/W | 0x0000_0000 | 20.3.2.4/5 |
| 0x0FC | PIT_RTI_TFLAG—RTI timer flag register | 32 | R/W | 0x0000_0000 | 20.3.2.5/6 |
| 0x100 | PIT_CH0_LDVAL—Channel 0 load value register | 32 | R/W | 0x0000_0000 | 20.3.2.2/5 |
| 0x104 | PIT_CH0_CVAL—Channel 0 current value register | 32 | R | 0x0000_0000 | 20.3.2.3/5 |
| 0x108 | PIT_CH0_TCTRL—Channel 0 timer control register | 32 | R/W | 0x0000_0000 | 20.3.2.4/5 |
| 0x10C | PIT_CH0_TFLAG—Channel 0 timer channel flag register | 32 | R/W | 0x0000_0000 | 20.3.2.5/6 |
| 0x110 | PIT_CH1_LDVAL—Channel 1 load value register | 32 | R/W | 0x0000_0000 | 20.3.2.2/5 |
| 0x114 | PIT_CH1_CVAL—Channel 1 current value register | 32 | R | 0x0000_0000 | 20.3.2.3/5 |
| 0x118 | PIT_CH1_TCTRL—Channel 1 timer control register | 32 | R/W | 0x0000_0000 | 20.3.2.4/5 |
| 0x11C | PIT_CH1_TFLAG—Channel 1 timer channel flag register | 32 | R/W | 0x0000_0000 | 20.3.2.5/6 |
| 0x120 | PIT_CH2_LDVAL—Channel 2 load value register | 32 | R/W | 0x0000_0000 | 20.3.2.2/5 |
| 0x124 | PIT_CH2_CVAL—Channel 2 current value register | 32 | R | 0x0000_0000 | 20.3.2.3/5 |
| 0x128 | PIT_CH2_TCTRL—Channel 2 timer control register | 32 | R/W | 0x0000_0000 | 20.3.2.4/5 |
| 0x12C | PIT_CH2_TFLAG—Channel 2 timer channel flag register | 32 | R/W | 0x0000_0000 | 20.3.2.5/6 |

Table 20-1. PIT_RTI Memory Map (continued)

| Base Address Offset (Base = 0xC3FF0000) | Register | Bits | Access | Reset Value | Section/Page |
|--|---|------|--------|-------------|----------------------------|
| 0x130 | PIT_CH3_LDVAL—Channel 3 load value register | 32 | R/W | 0x0000_0000 | 20.3.2.2/5 |
| 0x134 | PIT_CH3_CVAL—Channel 3 current value register | 32 | R | 0x0000_0000 | 20.3.2.3/5 |
| 0x138 | PIT_CH3_TCTRL—Channel 3 timer control register | 32 | R/W | 0x0000_0000 | 20.3.2.4/5 |
| 0x13C | PIT_CH3_TFLAG—Channel 3 timer channel flag register | 32 | R/W | 0x0000_0000 | 20.3.2.5/6 |

20.3.2 Register Descriptions

This section describes all PIT_RTI registers and their individual bits.

20.3.2.1 PIT Module Control Register (PIT_MCR)

This register provides a mechanism for enabling and disabling timers, and setting whether timers continue to count in debug mode.

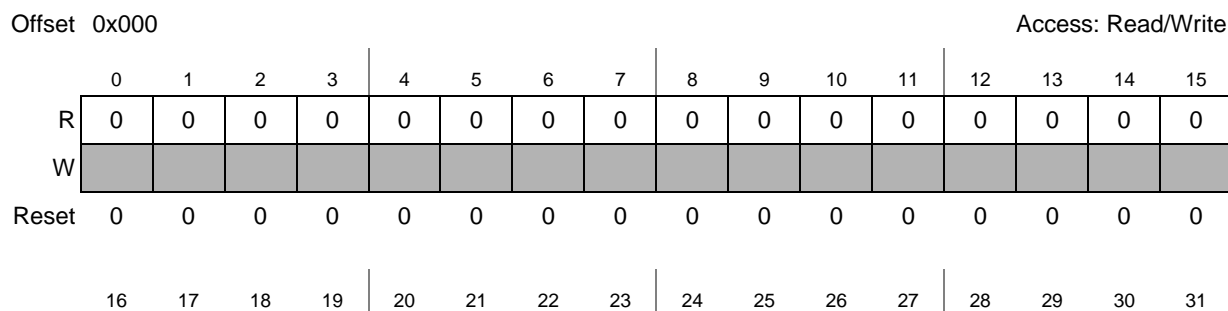

Figure 20-2. PIT Module Control Register (PIT_MCR)

Table 20-2. PITMCR Field Descriptions

| Field | Description |
|-----------|--|
| 0–2 | Reserved |
| 31 FRZ | Freeze. Allows the timers to be stopped when the device enters debug mode. 0 = Timers continue to run in debug mode. 1 = Timers are stopped in debug mode. |

20.3.2.2 Timer Load Value Register (PIT_RTI_LDVAL, PIT_CH n _LDVAL)

This register selects the timeout period for the timer interrupts.

Offset: channel_base + 0x00

Access: User read/write

RTI base = 0x0F0
 CH0 base = 0x100
 CH1 base = 0x110
 CH2 base = 0x120
 CH3 base = 0x130

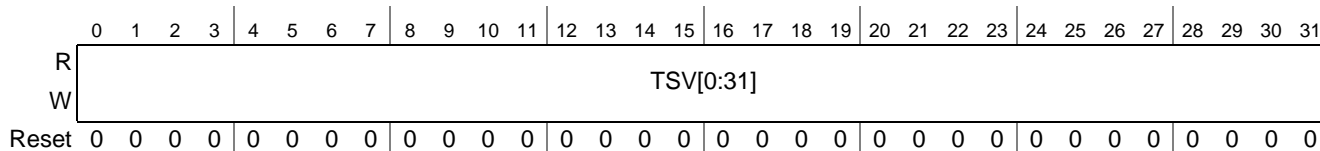

Figure 20-3. Timer Load Value Register (PIT_RTI_LDVAL, PIT_CH n _LDVAL)

Table 20-3. PIT_RTI_LDVAL, PIT_CH n _LDVAL Field Descriptions

| Field | Description |
|-------------|--|
| 0–31 TSV | Time Start Value Bits. These bits set the timer start value. The timer counts down until it reaches 0, then it generates an interrupt and loads this register value again. Writing a new value to this register does not restart the timer, instead the value is loaded once the timer expires. To abort the current cycle and start a timer period with the new value, the timer must be disabled and enabled again (see Figure 20-8). |

20.3.2.3 Current Timer Value Register (PIT_RTI_CVAL, PIT_CH n _CVAL)

This register indicates the current timer position.

Offset: channel_base + 0x04

Access: User read

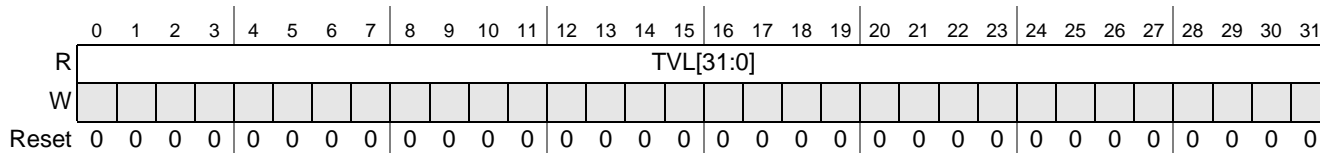

Figure 20-4. Current Timer Value Register (PIT_RTI_CVAL, PIT_CH n _CVAL)

Table 20-4. PIT_RTI_CVAL, PIT_CH n _CVAL Field Descriptions

| Field | Description |
|-------------|---|
| 0–31 TVL | Current Timer Value. These bits represent the current timer value. Note that the timer uses a downcounter. NOTE: The timer values are frozen in Debug mode if the FRZ bit is set in the PIT Module Control Register (see Figure 20-2) |

20.3.2.4 Timer Control Register (PIT_RTI_TCTRL, PIT_CH n _TCTRL)

This register contains the control bits for each timer.

Periodic Interrupt Timer (PIT_RTI)

Offset channel_base + 0x08

Access: Read/Write

RTI base = 0x0F0

CH0 base = 0x100

CH1 base = 0x110

CH2 base = 0x120

CH3 base = 0x130

| | | | | | | | | | | | | | | | | |
|-------|---|---|---|---|---|---|---|---|---|---|----|----|----|----|----|----|
| | 0 | 1 | 2 | 3 | 4 | 5 | 6 | 7 | 8 | 9 | 10 | 11 | 12 | 13 | 14 | 15 |
| R | 0 | 0 | 0 | 0 | 0 | 0 | 0 | 0 | 0 | 0 | 0 | 0 | 0 | 0 | 0 | 0 |
| W | | | | | | | | | | | | | | | | |
| Reset | 0 | 0 | 0 | 0 | 0 | 0 | 0 | 0 | 0 | 0 | 0 | 0 | 0 | 0 | 0 | 0 |

| | | | | | | | | | | | | | | | | |
|-------|----|----|----|----|----|----|----|----|----|----|----|----|----|----|-----|-----|
| | 16 | 17 | 18 | 19 | 20 | 21 | 22 | 23 | 24 | 25 | 26 | 27 | 28 | 29 | 30 | 31 |
| R | 0 | 0 | 0 | 0 | 0 | 0 | 0 | 0 | 0 | 0 | 0 | 0 | 0 | 0 | | |
| W | | | | | | | | | | | | | | | TIE | TEN |
| Reset | 0 | 0 | 0 | 0 | 0 | 0 | 0 | 0 | 0 | 0 | 0 | 0 | 0 | 0 | 0 | 0 |

Figure 20-5. Timer Control Register (PIT_RTI_TCTRL, PIT_CHn_TCTRL)

Table 20-5. PIT_RTI_TCTRL, PIT_CHn_TCTRL Field Descriptions

| Field | Description |
|-----------|--|
| 0–29 | Reserved |
| 30 TIE | Timer Interrupt Enable Bit. 0 Interrupt requests from Timer x are disabled 1 Interrupt is requested whenever TIF is set When an interrupt is pending (TIF set), enabling the interrupt immediately causes an interrupt event. To avoid this, the associated TIF flag must be cleared first. |
| 31 TEN | Timer Enable Bit. 0 Timer is disabled 1 Timer is active |

20.3.2.5 Timer Flag Register (PIT_RTI_TFLG, PIT_CHn_TFLG)

This register holds the PIT interrupt flag for each timer.

Offset channel_base + 0x0C

Access: Read/Write

 RTI base = 0x0F0
 CH0 base = 0x100
 CH1 base = 0x110
 CH2 base = 0x120
 CH3 base = 0x130

| | | | | | | | | | | | | | | | | |
|-------|---|---|---|---|---|---|---|---|---|---|----|----|----|----|----|----|
| | 0 | 1 | 2 | 3 | 4 | 5 | 6 | 7 | 8 | 9 | 10 | 11 | 12 | 13 | 14 | 15 |
| R | 0 | 0 | 0 | 0 | 0 | 0 | 0 | 0 | 0 | 0 | 0 | 0 | 0 | 0 | 0 | 0 |
| W | | | | | | | | | | | | | | | | |
| Reset | 0 | 0 | 0 | 0 | 0 | 0 | 0 | 0 | 0 | 0 | 0 | 0 | 0 | 0 | 0 | 0 |

| | | | | | | | | | | | | | | | | |
|-------|----|----|----|----|----|----|----|----|----|----|----|----|----|----|----|-----|
| | 16 | 17 | 18 | 19 | 20 | 21 | 22 | 23 | 24 | 25 | 26 | 27 | 28 | 29 | 30 | 31 |
| R | 0 | 0 | 0 | 0 | 0 | 0 | 0 | 0 | 0 | 0 | 0 | 0 | 0 | 0 | 0 | TIF |
| W | | | | | | | | | | | | | | | | |
| Reset | 0 | 0 | 0 | 0 | 0 | 0 | 0 | 0 | 0 | 0 | 0 | 0 | 0 | 0 | 0 | 0 |

Figure 20-6. Timer Flag Register (PIT_RTI_TFLG, PIT_CHn_TFLG)
Table 20-6. PIT_RTI_TFLG, PIT_CHn_TFLG Field Descriptions

| Field | Description |
|-----------|--|
| 0–30 | Reserved |
| 31 TIF | Time Interrupt Flag. TIF is set to 1 at the end of the timer period. This flag can be cleared only by writing it with a 1. Writing a 0 has no effect. If enabled (TIE = 1), TIF causes an interrupt request. 0 Time-out has not yet occurred 1 Time-out has occurred |

20.4 Functional Description

20.4.1 General

This section gives detailed information on the internal operation of the module. Each timer can be used to generate a unique interrupt vector.

20.4.1.1 Timers

Once enabled, the timers can be configured to generate interrupts at periodic intervals. The timer loads its start value, as specified in the LDVAL register, then counts down until the count reaches 0. Then the value in the LDVAL register is loaded again and the process repeats. Each time the timer reaches 0, an interrupt is generated if enabled, and the interrupt flag is set.

All interrupts can be enabled or masked (by setting the TIE bits in the TCTRL registers). A new interrupt can be generated only after the previous one is cleared.

If desired, the current counter value of the timer can be read via the CVAL registers.

Periodic Interrupt Timer (PIT_RTI)

The counter period can be restarted, by first disabling, then enabling the timer with the TEN bit (see [Figure 20-7](#)).

The counter period of a running timer can be modified, by first disabling the timer, setting a new load value and then enabling the timer again (see [Figure 20-8](#)). In the case of the RTI, because of the different clock domains (system clock / oscillator clock), a delay must be respected between setting the new value and re-enabling the RTI.

It is also possible to change the counter period without restarting the timer by writing the LDVAL register with the new load value. This value is loaded after the next trigger (counter reaches 0) event (see [Figure 20-9](#)).

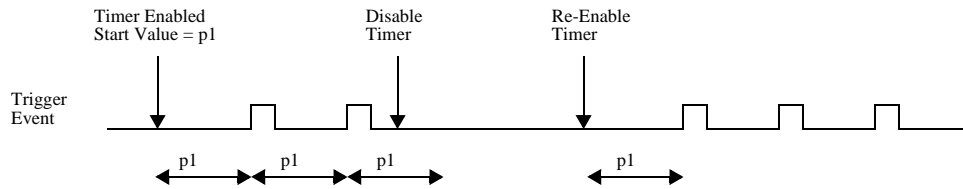

Figure 20-7. Stopping and Starting a Timer

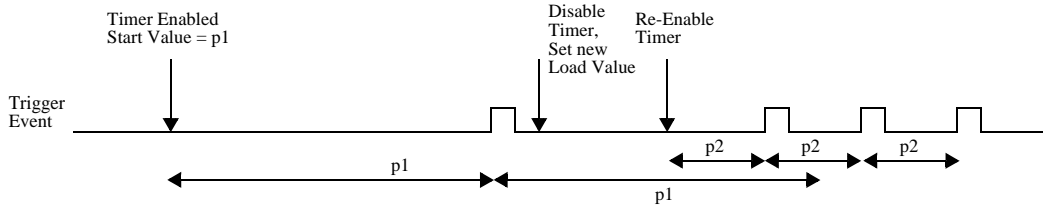

Figure 20-8. Modifying Running Timer Period

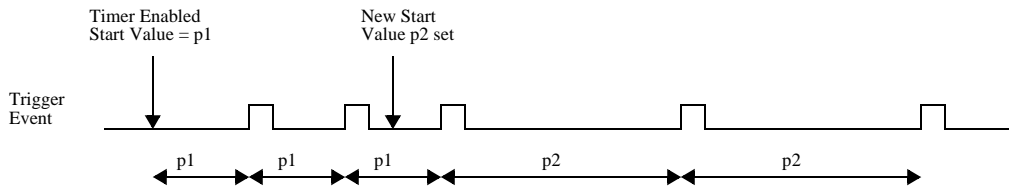

Figure 20-9. Dynamically Setting a New Load Value

20.4.1.2 Debug Mode

In debug mode the timers may be configured to stop when the debugger halts the device. This is intended to aid software development, allowing the developer to halt the processor, investigate the current state of the system (e.g. the timer values) and then continue the operation.

20.4.2 Interrupts

All of the timers support interrupt generation. Refer to [Section 10.4.1, Interrupt Request Sources](#), for related vector addresses and priorities.

Timer interrupts can be disabled by setting the timer PIT_CHn_TCTRL[TIE] bit to zero. The PIT_CHn_TFLG[TIF] bit is set to 1 when a timeout occurs on the associated timer, and is cleared by writing a 1 to that bit.

20.5 Initialization and Application Information

20.5.1 Example Configuration

In the example configuration:

- the PIT clock has a frequency of 50 MHz
- timer 1 shall create an interrupt every 5.12 ms

First the PIT module is activated by writing a 0 to the MDIS bit in the PITCTRL register.

The 50 MHz clock frequency equates to a clock period of 20 ns. Timer 1 needs to trigger every 5.12 ms/20 ns = 256000 cycles. The value for the LDVAL register trigger would be calculated as (period / clock period) - 1.

This means that PIT_PIT_CH1_LDVAL with 0003E7FF hex.

The interrupt for Timer 1 is enabled by setting PIT_CH1_TCTRL[TIE] bit. The timer is started by writing a 1 to the PIT_CH1_TCTRL[TEN] bit.

The following example pseudo-code matches the described setup:

```
// turn on PIT
PIT_MCR = 0x00;

// RTI
PIT_RTI_LDVAL = 0x004C4B3F; // setup RTI for 5000000 cycles
PIT_RTI_TCTRL[TIE] = 1; // let RTI generate interrupts
PIT_RTI_TCTRL[TEN] = 1; // start RTI

// Timer 1
PIT_CH1_LDVAL = 0x0003E7FF; // setup timer 1 for 256000 cycles
PIT_CH1_TCTRL[TIE] = 1; // enable Timer 1 interrupts
PIT_CH1_TCTRL[TEN] = 1; // start timer 1
```

20.5.2 Low Power Mode – Using the RTI for System Wakeup

This section describes the use of the low power mode, both with and without use of the RTI timer for wakeup.

20.5.2.1 Low Power Mode Without RTI Wakeup

The SIU_HALT register may be used to place certain peripherals selectively in low power mode. See [Section 7.3.1.28, Halt Register \(SIU_HLT\)](#), for more information about the SIU_HLT register. The general process for setting low power modes is:

1. Disable interrupts for any peripherals that are to be placed in low power mode and ensure there are no pending interrupts.
2. Using the bit assignment in the SIU_HLT register, set the bits for any modules where low power operation is desired. Note that the CPU (SIU_HLT[0]) bit should not be selected.
3. The SIU_HLTACK register indicates when a selected peripheral clock has stopped.
4. To re-enable the clock to any peripheral, clear the corresponding bit in the SIU_HLT register and re-enable the interrupts for the desired peripheral. The SIU_HLTACK updates accordingly when the peripheral clock has been re-enabled.

NOTE

Most of the peripherals have a MDIS (module disable) bit in the module control register that can be set to disable the module clock, reducing power consumption. In most cases the peripheral registers are still readable and writeable. The SIU_HALT register performs the same function on multiple modules with a single 32-bit write, however using the SIU_HALT function also disables R/W function on the peripheral registers for additional power saving.

20.5.2.2 Low Power Mode With RTI Wakeup

The RTI can be used in conjunction with the SIU_HALT register to enter and exit from low power mode. See [Section 7.3.1.28, Halt Register \(SIU_HLT\)](#), for more information about the SIU_HALT register. The general procedure for entering and exiting low power mode is:

1. Configure the interrupt handler for the RTI interrupt. The interrupt handler code can vary, depending on what behavior is required for the application upon exiting low power mode. More information on configuring and using the interrupts is found in [Section 10.5, Initialization and Application Information](#), of the Interrupt Controller chapter.
2. Configure the RTI for the desired timeout period as described in [Section 20.5.1, Example Configuration](#).
3. Disable interrupts for all peripherals to be placed in low power mode and ensure there are no pending interrupts.
4. Write the desired bits to the SIU_HLT register, selecting the modules that are to have the low power mode enabled. Note that if the CPU bit is also set for lowest power operation, an RTI interrupt is required to exit low power mode.
5. The CPU executes the ‘msync’, ‘isync’, and ‘wait’ instructions and the device enters low power mode. Note that the ‘msync’ and ‘isync’ instructions ensure that all current core operations complete before entering low power mode.

6. At the programmed RTI time interval, the RTI timer triggers an interrupt that is serviced by the interrupt controller. (The interrupt controller is not put in low power mode by the SIU_HALT register.) This interrupt also re-enables the CPU clock so that full CPU operation is restored.
7. In the RTI interrupt handler, the SIU_HALT register may be modified to restore operation as desired. In some cases where periodic operation is preferred, the interrupt handler may perform a set of tasks, and then write the SIU_HALT register mask and re-enter the low power mode by executing the 'msync', 'isync', and 'wait' instructions again. The next RTI timeout repeats the process.

NOTE

The RTI is a convenient mechanism for waking up the CPU in a controlled state once placed in low power mode. However, the CPU will also exit low power mode under any of the following conditions:

- Any external interrupt from interrupt controller
- Critical interrupt
- NMI event
- Core watchdog timeout
- Core fixed interval timeout
- Core decremter timeout
- Various debug events

Chapter 21

Enhanced Direct Memory Access Controller (eDMA)

21.1 Introduction

This device includes two enhanced direct memory access controller (eDMA) blocks. The eDMA is a second-generation platform block capable of performing complex data movements through n programmable channels ($n=64$ for eDMA_A, $n=32$ for eDMA_B), with minimal intervention from the host processor. The hardware microarchitecture includes a DMA engine that performs source and destination address calculations, and the actual data movement operations, along with an SRAM-based memory containing the transfer control descriptors (TCD) for the channels.

21.1.1 Block Diagram

Figure 21-1 shows a simplified block diagram of each eDMA.

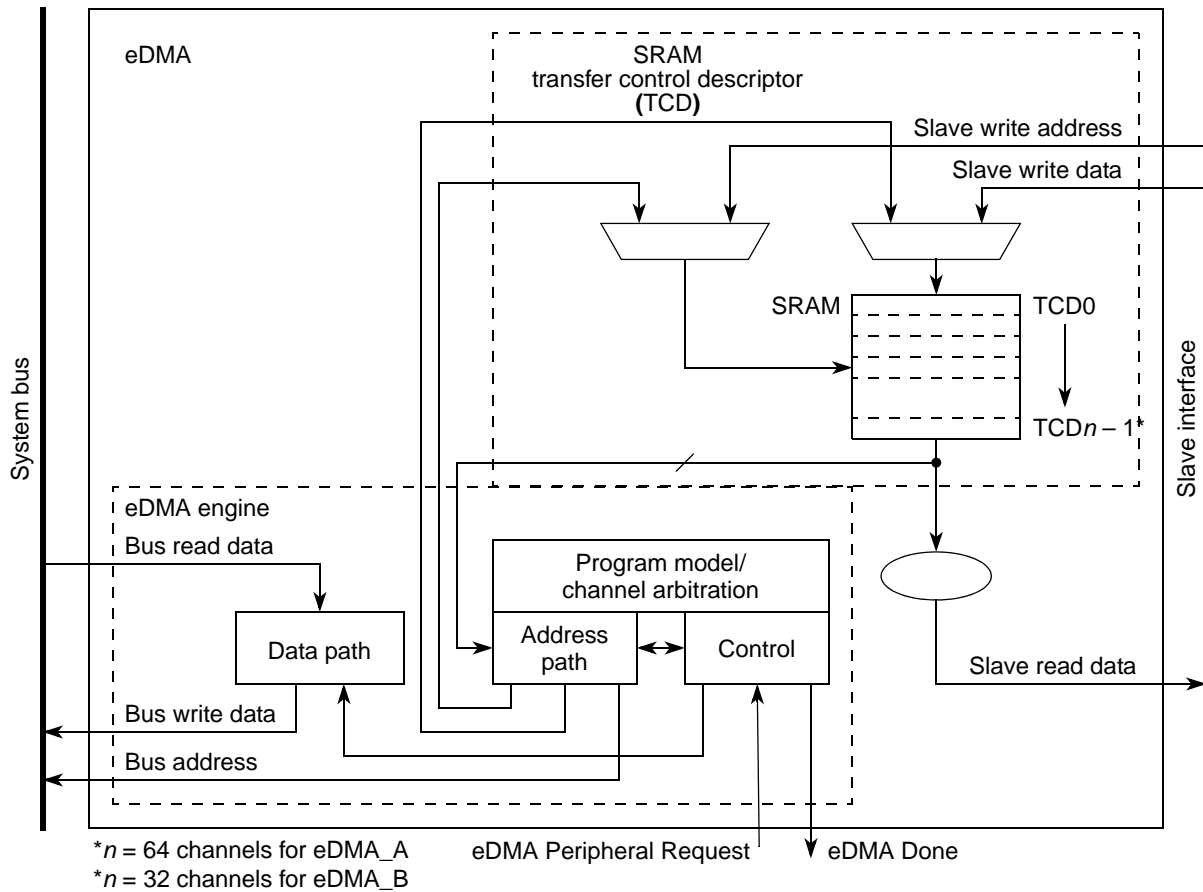

Figure 21-1. eDMA Block Diagram

21.1.2 Features

Each eDMA has these major features:

- All data movement via dual-address transfers: read from source, write to destination
 - Programmable source, destination addresses, transfer size, and support for enhanced addressing modes
- Both 32- and 64-channel implementation performs complex data transfers with minimal intervention from a host processor
 - 32 bytes of data registers, used as temporary storage to support burst transfers (refer to SSIZE bit)
 - Connections to the crossbar switch for bus mastering the data movement
- Transfer control descriptor organized to support two-deep, nested transfer operations
 - An inner data transfer loop defined by a minor byte transfer count

- An outer data transfer loop defined by a major iteration count
- Channel activation via one of three methods:
 - Explicit software initiation
 - Initiation via a channel-to-channel linking mechanism for continuous transfers
 - Peripheral-paced hardware requests (one per channel)
 - All three methods require one activation per execution of the minor loop
- Support for fixed-priority and round-robin channel arbitration
- Support for complex data structures
- Support to cancel transfers via software
- Channel completion reported via optional interrupt requests
 - One interrupt per channel, optionally asserted at completion of major iteration count
 - Error terminations are optionally enabled per channel and logically summed together to form a single error interrupt (32-channel eDMA) or two error interrupts (64-channel eDMA).
- Support for scatter-gather DMA processing
- Support for complex data structures
- Any channel can be programmed to be suspended by a higher priority channel's activation, before completion of a minor loop.

21.1.3 Modes of Operation

There are two main operating modes of eDMA: normal mode and debug mode. These modes are briefly described in this section.

21.1.3.1 Normal Mode

In normal mode, the eDMA is used to transfer data between a source and a destination. The source and destination can be a memory block or an I/O block capable of operation with the eDMA.

21.1.3.2 Debug Mode

In debug mode, the eDMA does not accept new transfer requests when its debug input signal is asserted. If the signal is asserted during transfer of a block of data described by a minor loop in the current active channel's TCD, the eDMA continues operation until completion of the minor loop.

21.2 External Signal Description

The eDMA has no external signals..

21.3 Memory Map and Registers

This section provides a detailed description of all eDMA registers.

21.3.1 Module Memory Map

The eDMA memory map is shown in [Table 21-1](#). The address of each register is given as an offset to the eDMA base address. Registers are listed in address order, identified by complete name and mnemonic, and list the type of accesses allowed. In register names, an “x” is used to indicate A or B, depending on which eDMA’s register you are using. If a register only exists in one of the eDMAs, the register description will state that.

The eDMA’s programming model is partitioned into two regions: the first region defines a number of registers providing control functions; however, the second region corresponds to the local transfer control descriptor memory.

Some registers are implemented as two 32-bit registers, and include H and L suffixes, signaling the high and low portions of the control function.

Base addresses of eDMA_x:

- EDMA_A_BASE = 0xFFF4_4000
- EDMA_B_BASE = 0xFFF5_4000

Table 21-1. eDMA Memory Map

| Offset from EDMA_x_BASE | Register | Bits | Access | Reset Value | Section/Page |
|-------------------------|--|------|--------|-------------|---------------------------------|
| 0x0000 | EDMA_x_MCR—eDMA module control register | 32 | R/W | 0x0000_E400 | 21.3.2.1/21-13 |
| 0x0004 | EDMA_x_ESR—eDMA error status register | 32 | R | 0x0000_0000 | 21.3.2.2/21-17 |
| 0x0008 | EDMA_A_ERQRH—eDMA_A enable request high register (channels 63–32) Reserved (eDMA_B) | 32 | R/W | 0000_0000 | 21.3.2.3/21-19 |
| 0x000C | EDMA_x_ERQL—eDMA enable request low register (channels 31–00) | 32 | R/W | 0x0000_0000 | 21.3.2.3/21-19 |
| 0x0010 | EDMA_A_EEIRLH—eDMA_A enable error interrupt register (channels 63–32) Reserved (eDMA_B) | 32 | R/W | 0x0000_0000 | 21.3.2.4/21-21 |
| 0x0014 | EDMA_x_EEIRL—eDMA enable error interrupt register (channels 31–00) | 32 | R/W | 0x0000_0000 | 21.3.2.4/21-21 |
| 0x0018 | EDMA_x_SERQR—eDMA set enable request register | 8 | W | 0x00 | 21.3.2.5/21-23 |
| 0x0019 | EDMA_x_CERQR—eDMA clear enable request register | 8 | W | 0x00 | 21.3.2.6/21-24 |
| 0x001A | EDMA_x_SEEIR—eDMA set enable error interrupt register | 8 | W | 0x00 | 21.3.2.7/21-25 |
| 0x001B | EDMA_x_CEEIR—eDMA clear enable error interrupt register | 8 | W | 0x00 | 21.3.2.8/21-26 |
| 0x001C | EDMA_x_CIRQR—eDMA clear interrupt request register | 8 | W | 0x00 | 21.3.2.9/21-27 |
| 0x001D | EDMA_x_CER—eDMA clear error register | 8 | W | 0x00 | 21.3.2.10/21-27 |

Table 21-1. eDMA Memory Map (continued)

| Offset from EDMA_x_BASE | Register | Bits | Access | Reset Value | Section/Page |
|-------------------------|---|------|--------|-------------|---------------------------------|
| 0x001E | EDMA_x_SSB—eDMA set start bit register | 8 | W | 0x00 | 21.3.2.11/21-28 |
| 0x001F | EDMA_x_CDSBR—eDMA clear done status bit register | 8 | W | 0x00 | 21.3.2.12/21-29 |
| 0x0020 | EDMA_A_IRQRH—eDMA_A interrupt request register (channels 63–32) Reserved (eDMA_B) | 32 | R/W | 0x0000_0000 | 21.3.2.13/21-30 |
| 0x0024 | EDMA_x_IRQRL—eDMA interrupt request register (channels 31–00) | 32 | R/W | 0x0000_0000 | 21.3.2.13/21-30 |
| 0x0028 | EDMA_A_ERH—eDMA_A error register (channels 63–32) Reserved (eDMA_B) | 32 | R/W | 0x0000_0000 | 21.3.2.14/21-31 |
| 0x002C | EDMA_x_ERL—eDMA error register (channels 31–00) | 32 | R/W | 0x0000_0000 | 21.3.2.14/21-31 |
| 0x0030 | EDMA_A_HRSH—eDMA_A hardware request status register (channels 63–32) Reserved (eDMA_B) | 32 | R/W | 0x0000_0000 | 21.3.2.15/21-32 |
| 0x0034 | EDMA_x_HRSL—eDMA hardware request status register (channels 31–00) | 32 | R/W | 0x0000_0000 | 21.3.2.15/21-32 |
| 0x0038 | EDMA_x_GWRH—eDMA Global Write Register High | 32 | R/W | 0x0000_0000 | 21.3.2.16/21-33 |
| 0x003C | EDMA_x_GWRL—eDMA Global Write Register Low | 32 | R/W | 0x0000_0000 | 21.3.2.16/21-33 |
| 0x0038–0x00FF | Reserved | | | | |
| 0x0100 | EDMA_x_CPR0—eDMA channel 0 priority register | 8 | R/W | 0x00 | 21.3.2.17/21-33 |
| 0x0101 | EDMA_x_CPR1—eDMA channel 1 priority register | 8 | R/W | 0x01 | 21.3.2.17/21-33 |
| 0x0102 | EDMA_x_CPR2—eDMA channel 2 priority register | 8 | R/W | 0x02 | 21.3.2.17/21-33 |
| 0x0103 | EDMA_x_CPR3—eDMA channel 3 priority register | 8 | R/W | 0x03 | 21.3.2.17/21-33 |
| 0x0104 | EDMA_x_CPR4—eDMA channel 4 priority register | 8 | R/W | 0x04 | 21.3.2.17/21-33 |
| 0x0105 | EDMA_x_CPR5—eDMA channel 5 priority register | 8 | R/W | 0x05 | 21.3.2.17/21-33 |
| 0x0106 | EDMA_x_CPR6—eDMA channel 6 priority register | 8 | R/W | 0x06 | 21.3.2.17/21-33 |
| 0x0107 | EDMA_x_CPR7—eDMA channel 7 priority register | 8 | R/W | 0x07 | 21.3.2.17/21-33 |
| 0x0108 | EDMA_x_CPR8—eDMA channel 8 priority register | 8 | R/W | 0x08 | 21.3.2.17/21-33 |
| 0x0109 | EDMA_x_CPR9—eDMA channel 9 priority register | 8 | R/W | 0x09 | 21.3.2.17/21-33 |
| 0x010A | EDMA_x_CPR10—eDMA channel 10 priority register | 8 | R/W | 0x0A | 21.3.2.17/21-33 |
| 0x010B | EDMA_x_CPR11—eDMA channel 11 priority register | 8 | R/W | 0x0B | 21.3.2.17/21-33 |
| 0x010C | EDMA_x_CPR12—eDMA channel 12 priority register | 8 | R/W | 0x0C | 21.3.2.17/21-33 |
| 0x010D | EDMA_x_CPR13—eDMA channel 13 priority register | 8 | R/W | 0x0D | 21.3.2.17/21-33 |
| 0x010E | EDMA_x_CPR14—eDMA channel 14 priority register | 8 | R/W | 0x0E | 21.3.2.17/21-33 |
| 0x010F | EDMA_x_CPR15—eDMA channel 15 priority register | 8 | R/W | 0x0F | 21.3.2.17/21-33 |

Table 21-1. eDMA Memory Map (continued)

| Offset from EDMA_x_BASE | Register | Bits | Access | Reset Value | Section/Page |
|-------------------------|--|------|--------|-------------|---------------------------------|
| 0x0110 | EDMA_x_CPR16—eDMA channel 16 priority register | 8 | R/W | 0x10 | 21.3.2.17/21-33 |
| 0x0111 | EDMA_x_CPR17—eDMA channel 17 priority register | 8 | R/W | 0x11 | 21.3.2.17/21-33 |
| 0x0112 | EDMA_x_CPR18—eDMA channel 18 priority register | 8 | R/W | 0x12 | 21.3.2.17/21-33 |
| 0x0113 | EDMA_x_CPR19—eDMA channel 19 priority register | 8 | R/W | 0x13 | 21.3.2.17/21-33 |
| 0x0114 | EDMA_x_CPR20—eDMA channel 20 priority register | 8 | R/W | 0x14 | 21.3.2.17/21-33 |
| 0x0115 | EDMA_x_CPR21—eDMA channel 21 priority register | 8 | R/W | 0x15 | 21.3.2.17/21-33 |
| 0x0116 | EDMA_x_CPR22—eDMA channel 22 priority register | 8 | R/W | 0x16 | 21.3.2.17/21-33 |
| 0x0117 | EDMA_x_CPR23—eDMA channel 23 priority register | 8 | R/W | 0x17 | 21.3.2.17/21-33 |
| 0x0118 | EDMA_x_CPR24—eDMA channel 24 priority register | 8 | R/W | 0x18 | 21.3.2.17/21-33 |
| 0x0119 | EDMA_x_CPR25—eDMA channel 25 priority register | 8 | R/W | 0x19 | 21.3.2.17/21-33 |
| 0x011A | EDMA_x_CPR26—eDMA channel 26 priority register | 8 | R/W | 0x1A | 21.3.2.17/21-33 |
| 0x011B | EDMA_x_CPR27—eDMA channel 27 priority register | 8 | R/W | 0x1B | 21.3.2.17/21-33 |
| 0x011C | EDMA_x_CPR28—eDMA channel 28 priority register | 8 | R/W | 0x1C | 21.3.2.17/21-33 |
| 0x011D | EDMA_x_CPR29—eDMA channel 29 priority register | 8 | R/W | 0x1D | 21.3.2.17/21-33 |
| 0x011E | EDMA_x_CPR30—eDMA channel 30 priority register | 8 | R/W | 0x1E | 21.3.2.17/21-33 |
| 0x011F | EDMA_x_CPR31—eDMA channel 31 priority register | 8 | R/W | 0x1F | 21.3.2.17/21-33 |
| 0x0120 | EDMA_A_CPR32—eDMA channel 32 priority register | 8 | R/W | 0x20 | 21.3.2.17/21-33 |
| 0x0121 | EDMA_A_CPR33—eDMA channel 33 priority register | 8 | R/W | 0x21 | 21.3.2.17/21-33 |
| 0x0122 | EDMA_A_CPR34—eDMA channel 34 priority register | 8 | R/W | 0x22 | 21.3.2.17/21-33 |
| 0x0123 | EDMA_A_CPR35—eDMA channel 35 priority register | 8 | R/W | 0x23 | 21.3.2.17/21-33 |
| 0x0124 | EDMA_A_CPR36—eDMA channel 36 priority register | 8 | R/W | 0x24 | 21.3.2.17/21-33 |
| 0x0125 | EDMA_A_CPR37—eDMA channel 37 priority register | 8 | R/W | 0x25 | 21.3.2.17/21-33 |
| 0x0126 | EDMA_A_CPR38—eDMA channel 38 priority register | 8 | R/W | 0x26 | 21.3.2.17/21-33 |
| 0x0127 | EDMA_A_CPR39—eDMA channel 39 priority register | 8 | R/W | 0x27 | 21.3.2.17/21-33 |
| 0x0128 | EDMA_A_CPR40—eDMA channel 40 priority register | 8 | R/W | 0x28 | 21.3.2.17/21-33 |
| 0x0129 | EDMA_A_CPR41—eDMA channel 41 priority register | 8 | R/W | 0x29 | 21.3.2.17/21-33 |
| 0x012A | EDMA_A_CPR42—eDMA channel 42 priority register | 8 | R/W | 0x2A | 21.3.2.17/21-33 |
| 0x012B | EDMA_A_CPR43—eDMA channel 43 priority register | 8 | R/W | 0x2B | 21.3.2.17/21-33 |
| 0x012C | EDMA_A_CPR44—eDMA channel 44 priority register | 8 | R/W | 0x2C | 21.3.2.17/21-33 |
| 0x012D | EDMA_A_CPR45—eDMA channel 45 priority register | 8 | R/W | 0x2D | 21.3.2.17/21-33 |
| 0x012E | EDMA_A_CPR46—eDMA channel 46 priority register | 8 | R/W | 0x2E | 21.3.2.17/21-33 |
| 0x012F | EDMA_A_CPR47—eDMA channel 47 priority register | 8 | R/W | 0x2F | 21.3.2.17/21-33 |

Table 21-1. eDMA Memory Map (continued)

| Offset from EDMA_x_BASE | Register | Bits | Access | Reset Value | Section/Page |
|-------------------------|--|------|--------|----------------|---------------------------------|
| 0x0130 | EDMA_A_CPR48—eDMA channel 48 priority register | 8 | R/W | 0x30 | 21.3.2.17/21-33 |
| 0x0131 | EDMA_A_CPR49—eDMA channel 49 priority register | 8 | R/W | 0x31 | 21.3.2.17/21-33 |
| 0x0132 | EDMA_A_CPR50—eDMA channel 50 priority register | 8 | R/W | 0x32 | 21.3.2.17/21-33 |
| 0x0133 | EDMA_A_CPR51—eDMA channel 51 priority register | 8 | R/W | 0x33 | 21.3.2.17/21-33 |
| 0x0134 | EDMA_A_CPR52—eDMA channel 52 priority register | 8 | R/W | 0x34 | 21.3.2.17/21-33 |
| 0x0135 | EDMA_A_CPR53—eDMA channel 53 priority register | 8 | R/W | 0x35 | 21.3.2.17/21-33 |
| 0x0136 | EDMA_A_CPR54—eDMA channel 54 priority register | 8 | R/W | 0x36 | 21.3.2.17/21-33 |
| 0x0137 | EDMA_A_CPR55—eDMA channel 55 priority register | 8 | R/W | 0x37 | 21.3.2.17/21-33 |
| 0x0138 | EDMA_A_CPR56—eDMA channel 56 priority register | 8 | R/W | 0x38 | 21.3.2.17/21-33 |
| 0x0139 | EDMA_A_CPR57—eDMA channel 57 priority register | 8 | R/W | 0x39 | 21.3.2.17/21-33 |
| 0x013A | EDMA_A_CPR58—eDMA channel 58 priority register | 8 | R/W | 0x3A | 21.3.2.17/21-33 |
| 0x013B | EDMA_A_CPR59—eDMA channel 59 priority register | 8 | R/W | 0x3B | 21.3.2.17/21-33 |
| 0x013C | EDMA_A_CPR60—eDMA channel 60 priority register | 8 | R/W | 0x3C | 21.3.2.17/21-33 |
| 0x013D | EDMA_A_CPR61—eDMA channel 61 priority register | 8 | R/W | 0x3D | 21.3.2.17/21-33 |
| 0x013E | EDMA_A_CPR62—eDMA channel 62 priority register | 8 | R/W | 0x3E | 21.3.2.17/21-33 |
| 0x013F | EDMA_A_CPR63—eDMA channel 63 priority register | 8 | R/W | 0x3F | 21.3.2.17/21-33 |
| 0x0140–0x0FFF | Reserved | | | | |
| 0x1000 | EDMA_x_TCD00—eDMA transfer control descriptor 00 | 256 | R/W | — ¹ | 21.3.2.18/21-34 |
| 0x1020 | EDMA_x_TCD01—eDMA transfer control descriptor 01 | 256 | R/W | — ¹ | 21.3.2.18/21-34 |
| 0x1040 | EDMA_x_TCD02—eDMA transfer control descriptor 02 | 256 | R/W | — ¹ | 21.3.2.18/21-34 |
| 0x1060 | EDMA_x_TCD03—eDMA transfer control descriptor 03 | 256 | R/W | — ¹ | 21.3.2.18/21-34 |
| 0x1080 | EDMA_x_TCD04—eDMA transfer control descriptor 04 | 256 | R/W | — ¹ | 21.3.2.18/21-34 |
| 0x10A0 | EDMA_x_TCD05—eDMA transfer control descriptor 05 | 256 | R/W | — ¹ | 21.3.2.18/21-34 |
| 0x10C0 | EDMA_x_TCD06—eDMA transfer control descriptor 06 | 256 | R/W | — ¹ | 21.3.2.18/21-34 |
| 0x10E0 | EDMA_x_TCD07—eDMA transfer control descriptor 07 | 256 | R/W | — ¹ | 21.3.2.18/21-34 |
| 0x1100 | EDMA_x_TCD08—eDMA transfer control descriptor 08 | 256 | R/W | — ¹ | 21.3.2.18/21-34 |
| 0x1120 | EDMA_x_TCD09—eDMA transfer control descriptor 09 | 256 | R/W | — ¹ | 21.3.2.18/21-34 |
| 0x1140 | EDMA_x_TCD10—eDMA transfer control descriptor 10 | 256 | R/W | — ¹ | 21.3.2.18/21-34 |
| 0x1160 | EDMA_x_TCD11—eDMA transfer control descriptor 11 | 256 | R/W | — ¹ | 21.3.2.18/21-34 |
| 0x1180 | EDMA_x_TCD12—eDMA transfer control descriptor 12 | 256 | R/W | — ¹ | 21.3.2.18/21-34 |
| 0x11A0 | EDMA_x_TCD13—eDMA transfer control descriptor 13 | 256 | R/W | — ¹ | 21.3.2.18/21-34 |
| 0x11C0 | EDMA_x_TCD14—eDMA transfer control descriptor 14 | 256 | R/W | — ¹ | 21.3.2.18/21-34 |

Table 21-1. eDMA Memory Map (continued)

| Offset from EDMA_x_BASE | Register | Bits | Access | Reset Value | Section/Page |
|-------------------------|--|------|--------|----------------|-----------------|
| 0x11E0 | EDMA_x_TCD15—eDMA transfer control descriptor 15 | 256 | R/W | — ¹ | 21.3.2.18/21-34 |
| 0x1200 | EDMA_x_TCD16—eDMA transfer control descriptor 16 | 256 | R/W | — ¹ | 21.3.2.18/21-34 |
| 0x1220 | EDMA_x_TCD17—eDMA transfer control descriptor 17 | 256 | R/W | — ¹ | 21.3.2.18/21-34 |
| 0x1240 | EDMA_x_TCD18—eDMA transfer control descriptor 18 | 256 | R/W | — ¹ | 21.3.2.18/21-34 |
| 0x1260 | EDMA_x_TCD19—eDMA transfer control descriptor 19 | 256 | R/W | — ¹ | 21.3.2.18/21-34 |
| 0x1280 | EDMA_x_TCD20—eDMA transfer control descriptor 20 | 256 | R/W | — ¹ | 21.3.2.18/21-34 |
| 0x12A0 | EDMA_x_TCD21—eDMA transfer control descriptor 21 | 256 | R/W | — ¹ | 21.3.2.18/21-34 |
| 0x12C0 | EDMA_x_TCD22—eDMA transfer control descriptor 22 | 256 | R/W | — ¹ | 21.3.2.18/21-34 |
| 0x12E0 | EDMA_x_TCD23—eDMA transfer control descriptor 23 | 256 | R/W | — ¹ | 21.3.2.18/21-34 |
| 0x1300 | EDMA_x_TCD24—eDMA transfer control descriptor 24 | 256 | R/W | — ¹ | 21.3.2.18/21-34 |
| 0x1320 | EDMA_x_TCD25—eDMA transfer control descriptor 25 | 256 | R/W | — ¹ | 21.3.2.18/21-34 |
| 0x1340 | EDMA_x_TCD26—eDMA transfer control descriptor 26 | 256 | R/W | — ¹ | 21.3.2.18/21-34 |
| 0x1360 | EDMA_x_TCD27—eDMA transfer control descriptor 27 | 256 | R/W | — ¹ | 21.3.2.18/21-34 |
| 0x1380 | EDMA_x_TCD28—eDMA transfer control descriptor 28 | 256 | R/W | — ¹ | 21.3.2.18/21-34 |
| 0x13A0 | EDMA_x_TCD29—eDMA transfer control descriptor 29 | 256 | R/W | — ¹ | 21.3.2.18/21-34 |
| 0x13C0 | EDMA_x_TCD30—eDMA transfer control descriptor 30 | 256 | R/W | — ¹ | 21.3.2.18/21-34 |
| 0x13E0 | EDMA_x_TCD31—eDMA transfer control descriptor 31 | 256 | R/W | — ¹ | 21.3.2.18/21-34 |
| 0x1400 | EDMA_A_TCD32—eDMA transfer control descriptor 32 | 256 | R/W | — ¹ | 21.3.2.18/21-34 |
| 0x1420 | EDMA_A_TCD33—eDMA transfer control descriptor 33 | 256 | R/W | — ¹ | 21.3.2.18/21-34 |
| 0x1440 | EDMA_A_TCD34—eDMA transfer control descriptor 34 | 256 | R/W | — ¹ | 21.3.2.18/21-34 |
| 0x1460 | EDMA_A_TCD35—eDMA transfer control descriptor 35 | 256 | R/W | — ¹ | 21.3.2.18/21-34 |
| 0x1480 | EDMA_A_TCD36—eDMA transfer control descriptor 36 | 256 | R/W | — ¹ | 21.3.2.18/21-34 |
| 0x14A0 | EDMA_A_TCD37—eDMA transfer control descriptor 37 | 256 | R/W | — ¹ | 21.3.2.18/21-34 |
| 0x14C0 | EDMA_A_TCD38—eDMA transfer control descriptor 38 | 256 | R/W | — ¹ | 21.3.2.18/21-34 |
| 0x14E0 | EDMA_A_TCD39—eDMA transfer control descriptor 39 | 256 | R/W | — ¹ | 21.3.2.18/21-34 |
| 0x1500 | EDMA_A_TCD40—eDMA transfer control descriptor 40 | 256 | R/W | — ¹ | 21.3.2.18/21-34 |
| 0x1520 | EDMA_A_TCD41—eDMA transfer control descriptor 41 | 256 | R/W | — ¹ | 21.3.2.18/21-34 |
| 0x1540 | EDMA_A_TCD42—eDMA transfer control descriptor 42 | 256 | R/W | — ¹ | 21.3.2.18/21-34 |
| 0x1560 | EDMA_A_TCD43—eDMA transfer control descriptor 43 | 256 | R/W | — ¹ | 21.3.2.18/21-34 |
| 0x1580 | EDMA_A_TCD44—eDMA transfer control descriptor 44 | 256 | R/W | — ¹ | 21.3.2.18/21-34 |
| 0x15A0 | EDMA_A_TCD45—eDMA transfer control descriptor 45 | 256 | R/W | — ¹ | 21.3.2.18/21-34 |
| 0x15C0 | EDMA_A_TCD46—eDMA transfer control descriptor 46 | 256 | R/W | — ¹ | 21.3.2.18/21-34 |

Table 21-1. eDMA Memory Map (continued)

| Offset from EDMA_x_BASE | Register | Bits | Access | Reset Value | Section/Page |
|-------------------------|--|------|--------|----------------|-----------------|
| 0x15E0 | EDMA_A_TCD47—eDMA transfer control descriptor 47 | 256 | R/W | — ¹ | 21.3.2.18/21-34 |
| 0x1600 | EDMA_A_TCD48—eDMA transfer control descriptor 48 | 256 | R/W | — ¹ | 21.3.2.18/21-34 |
| 0x1620 | EDMA_A_TCD49—eDMA transfer control descriptor 49 | 256 | R/W | — ¹ | 21.3.2.18/21-34 |
| 0x1640 | EDMA_A_TCD50—eDMA transfer control descriptor 50 | 256 | R/W | — ¹ | 21.3.2.18/21-34 |
| 0x1660 | EDMA_A_TCD51—eDMA transfer control descriptor 51 | 256 | R/W | — ¹ | 21.3.2.18/21-34 |
| 0x1680 | EDMA_A_TCD52—eDMA transfer control descriptor 52 | 256 | R/W | — ¹ | 21.3.2.18/21-34 |
| 0x16A0 | EDMA_A_TCD53—eDMA transfer control descriptor 53 | 256 | R/W | — ¹ | 21.3.2.18/21-34 |
| 0x16C0 | EDMA_A_TCD54—eDMA transfer control descriptor 54 | 256 | R/W | — ¹ | 21.3.2.18/21-34 |
| 0x16E0 | EDMA_A_TCD55—eDMA transfer control descriptor 55 | 256 | R/W | — ¹ | 21.3.2.18/21-34 |
| 0x1700 | EDMA_A_TCD56—eDMA transfer control descriptor 56 | 256 | R/W | — ¹ | 21.3.2.18/21-34 |
| 0x1720 | EDMA_A_TCD57—eDMA transfer control descriptor 57 | 256 | R/W | — ¹ | 21.3.2.18/21-34 |
| 0x1740 | EDMA_A_TCD58—eDMA transfer control descriptor 58 | 256 | R/W | — ¹ | 21.3.2.18/21-34 |
| 0x1760 | EDMA_A_TCD59—eDMA transfer control descriptor 59 | 256 | R/W | — ¹ | 21.3.2.18/21-34 |
| 0x1780 | EDMA_A_TCD60—eDMA transfer control descriptor 60 | 256 | R/W | — ¹ | 21.3.2.18/21-34 |
| 0x17A0 | EDMA_A_TCD61—eDMA transfer control descriptor 61 | 256 | R/W | — ¹ | 21.3.2.18/21-34 |
| 0x17C0 | EDMA_A_TCD62—eDMA transfer control descriptor 62 | 256 | R/W | — ¹ | 21.3.2.18/21-34 |
| 0x17E0 | EDMA_A_TCD63—eDMA transfer control descriptor 63 | 256 | R/W | — ¹ | 21.3.2.18/21-34 |

¹ See specific register description.

Table 21-2. eDMA_A 32-bit Memory Map—Graphical View

| Address | Register | | | |
|-------------|--|--|---|--|
| 0xFFF4_4000 | eDMA Control Register (EDMA_A_CR) | | | |
| 0xFFF4_4004 | eDMA Error Status (EDMA_A_ESR) | | | |
| 0xFFF4_4008 | eDMA Enable Request Register High (EDMA_A_ERQRH) | | | |
| 0xFFF4_400C | eDMA Enable Request Register Low (EDMA_A_ERQRL) | | | |
| 0xFFF4_4010 | eDMA Enable Error Interrupt Register High (EDMA_A_EEIRH) | | | |
| 0xFFF4_4014 | eDMA Enable Error Interrupt Register Low (EDMA_A_EEIRL) | | | |
| 0xFFF4_4018 | eDMA Set Enable Request (EDMA_A_SERQR) | eDMA Clear Enable Request (EDMA_A_CERQR) | eDMA Set Enable Error Interrupt (EDMA_A_SEEIR) | eDMA Clear Enable Error Interrupt (EDMA_A_CEEIR) |
| 0xFFF4_401C | eDMA Clear Interrupt Request (EDMA_A_CIRQR) | eDMA Clear Error (EDMA_A_CER) | eDMA Set Start Bit, Activate Channel (EDMA_A_SSB) | eDMA Clear Done Status Bit (EDMA_A_CDSBR) |

Table 21-2. eDMA_A 32-bit Memory Map—Graphical View (continued)

| Address | Register | | | |
|--------------------------------|--|--|--|---|
| | 0xFFFF4_4020 | eDMA Interrupt Request High (EDMA_A_IRQRH channels 63–48) | | eDMA Interrupt Request High (EDMA_A_IRQRH, Channels 47–32) |
| 0xFFFF4_4024 | eDMA Interrupt Request Low (EDMA_A_IRQRL, channels 31–16) | | eDMA Interrupt Request Low (EDMA_A_IRQRL, Channels 15–00) | |
| 0xFFFF4_4028 | eDMA Error High (EDMA_A_ERL, channels 63–48) | | eDMA Error High (EDMA_A_ERL, Channels 47–32) | |
| 0xFFFF4_402C | eDMA Error Low (EDMA_A_ERL, channels 31–16) | | eDMA Error Low (EDMA_A_ERL, Channels 15–00) | |
| 0xFFFF4_4030 | eDMA Hardware Request Status High (EDMA_A_HRSL, channels 63–48) | | eDMA Hardware Request Status High (EDMA_A_HRSL, Channels 47–32) | |
| 0xFFFF4_4034 | eDMA Hardware Request Status Low (EDMA_A_HRSL, channels 31–16) | | eDMA Hardware Request Status Low (EDMA_A_HRSL, Channels 15–00) | |
| 0xFFFF4_4038 – 0xFFFF4_40FC | Reserved | | | |
| 0xFFFF4_4100 | eDMA Channel 0 Priority (EDMA_A_CPR0) | eDMA Channel 1 Priority (EDMA_A_CPR1) | eDMA Channel 2 Priority (EDMA_A_CPR2) | eDMA Channel 3 Priority (EDMA_A_CPR3) |
| 0xFFFF4_4104 | eDMA Channel 4 Priority (EDMA_A_CPR4) | eDMA Channel 5 Priority (EDMA_A_CPR5) | eDMA Channel 6 Priority (EDMA_A_CPR6) | eDMA Channel 7 Priority (EDMA_A_CPR7) |
| 0xFFFF4_4108 | eDMA Channel 8 Priority (EDMA_A_CPR8) | eDMA Channel 9 Priority (EDMA_A_CPR9) | eDMA Channel 10 Priority (EDMA_A_CPR10) | eDMA Channel 11 Priority (EDMA_A_CPR11) |
| 0xFFFF4_410C | eDMA Channel 12 Priority (EDMA_A_CPR12) | eDMA Channel 13 Priority (EDMA_A_CPR13) | eDMA Channel 14 Priority (EDMA_A_CPR14) | eDMA Channel 15 Priority (EDMA_A_CPR15) |
| 0xFFFF4_4110 | eDMA Channel 16 Priority (EDMA_A_CPR16) | eDMA Channel 17 Priority (EDMA_A_CPR17) | eDMA Channel 18 Priority (EDMA_A_CPR18) | eDMA Channel 19 Priority (EDMA_A_CPR19) |
| 0xFFFF4_4114 | eDMA Channel 20 Priority (EDMA_A_CPR20) | eDMA Channel 21 Priority (EDMA_A_CPR21) | eDMA Channel 22 Priority (EDMA_A_CPR22) | eDMA Channel 23 Priority (EDMA_A_CPR23) |
| 0xFFFF4_4118 | eDMA Channel 24 Priority (EDMA_A_CPR24) | eDMA Channel 25 Priority (EDMA_A_CPR25) | eDMA Channel 26 Priority (EDMA_A_CPR26) | eDMA Channel 27 Priority (EDMA_A_CPR27) |
| 0xFFFF4_411C | eDMA Channel 28 Priority (EDMA_A_CPR28) | eDMA Channel 29 Priority (EDMA_A_CPR29) | eDMA Channel 30 Priority (EDMA_A_CPR30) | eDMA Channel 31 Priority (EDMA_A_CPR31) |
| 0xFFFF4_4120 | eDMA Channel 32 Priority (EDMA_A_CPR32) | eDMA Channel 33 Priority (EDMA_A_CPR33) | eDMA Channel 34 Priority (EDMA_A_CPR34) | eDMA Channel 35 Priority (EDMA_A_CPR35) |

Table 21-2. eDMA_A 32-bit Memory Map—Graphical View (continued)

| Address | Register | | | |
|--------------------------------|---|---|---|---|
| 0xFFFF4_4124 | eDMA Channel 36 Priority (EDMA_A_CPR36) | eDMA Channel 37 Priority (EDMA_A_CPR37) | eDMA Channel 38 Priority (EDMA_A_CPR38) | eDMA Channel 39 Priority (EDMA_A_CPR39) |
| 0xFFFF4_4128 | eDMA Channel 40 Priority (EDMA_A_CPR40) | eDMA Channel 41 Priority (EDMA_A_CPR41) | eDMA Channel 42 Priority (EDMA_A_CPR42) | eDMA Channel 43 Priority (EDMA_A_CPR43) |
| 0xFFFF4_412C | eDMA Channel 44 Priority (EDMA_A_CPR44) | eDMA Channel 45 Priority (EDMA_A_CPR45) | eDMA Channel 46 Priority (EDMA_A_CPR46) | eDMA Channel 47 Priority (EDMA_A_CPR47) |
| 0xFFFF4_4130 | eDMA Channel 48 Priority (EDMA_A_CPR48) | eDMA Channel 49 Priority (EDMA_A_CPR49) | eDMA Channel 50 Priority (EDMA_A_CPR50) | eDMA Channel 51 Priority (EDMA_A_CPR51) |
| 0xFFFF4_4134 | eDMA Channel 52 Priority (EDMA_A_CPR52) | eDMA Channel 53 Priority (EDMA_A_CPR53) | eDMA Channel 54 Priority (EDMA_A_CPR54) | eDMA Channel 55 Priority (EDMA_A_CPR55) |
| 0xFFFF4_4138 | eDMA Channel 56 Priority (EDMA_A_CPR56) | eDMA Channel 57 Priority (EDMA_A_CPR57) | eDMA Channel 58 Priority (EDMA_A_CPR58) | eDMA Channel 59 Priority (EDMA_A_CPR59) |
| 0xFFFF4_413C | eDMA Channel 60 Priority (EDMA_A_CPR60) | eDMA Channel 61 Priority (EDMA_A_CPR61) | eDMA Channel 62 Priority (EDMA_A_CPR62) | eDMA Channel 63 Priority (EDMA_A_CPR63) |
| 0xFFFF4_4140 – 0xFFFF4_4FFF | Reserved | | | |
| 0xFFFF4_5000 – 0xFFFF4_51FC | EDMA_A_TCD00–EDMA_A_TCD15 | | | |
| 0xFFFF4_5200 – 0xFFFF4_53FC | EDMA_A_TCD16–EDMA_A_TCD31 | | | |
| 0xFFFF4_5400 – 0xFFFF4_55FC | EDMA_A_TCD32–EDMA_A_TCD47 | | | |
| 0xFFFF4_5600 – 0xFFFF4_57FC | EDMA_A_TCD48–EDMA_A_TCD63 | | | |
| 0xFFFF4_5800 | Reserved | | | |

Table 21-3. eDMA_B 32-bit Memory Map—Graphical View

| Address | Register | |
|--------------|---|---|
| 0xFFFF5_4000 | eDMA Control Register (EDMA_B_CR) | |
| 0xFFFF5_4004 | eDMA Error Status (EDMA_B_ESR) | |
| 0xFFFF5_4008 | Reserved | |
| 0xFFFF5_400C | eDMA Enable Request (EDMA_B_ERQRL, channels 31–16) | eDMA Enable Request (EDMA_B_ERQRL, channels 15–00) |
| 0xFFFF5_4010 | Reserved | |

Table 21-3. eDMA_B 32-bit Memory Map—Graphical View (continued)

| Address | Register | | | |
|-----------------------------|---|---|---|---|
| 0xFFFF5_4014 | eDMA Enable Error Interrupt Low (EDMA_B_EEIRL, channels 31–16) | | eDMA Enable Error Interrupt Low (EDMA_B_EEIRL, Channels 15–00) | |
| 0xFFFF5_4018 | eDMA Set Enable Request (EDMA_B_SERQR) | eDMA Clear Enable Request (EDMA_B_CERQR) | eDMA Set Enable Error Interrupt (EDMA_B_SEEIR) | eDMA Clear Enable Error Interrupt (EDMA_B_CEEIR) |
| 0xFFFF5_401C | eDMA Clear Interrupt Request (EDMA_B_CIRQR) | eDMA Clear Error (EDMA_B_CER) | eDMA Set Start Bit, Activate Channel (EDMA_B_SSBP) | eDMA Clear Done Status Bit (EDMA_B_CDSBR) |
| 0xFFFF5_4020 | Reserved | | | |
| 0xFFFF5_4024 | eDMA Interrupt Request (EDMA_B_IRQRL, channels 31–16) | | eDMA Interrupt Request (EDMA_B_IRQRL, Channels 15–00) | |
| 0xFFFF5_4028 | Reserved | | | |
| 0xFFFF5_402C | eDMA Error (EDMA_B_ERL, channels 31–16) | | eDMA Error (EDMA_B_ERL, Channels 15–00) | |
| 0xFFFF5_4030 | Reserved | | | |
| 0xFFFF5_4034 | eDMA Hardware Request Status (EDMA_B_HRSL, channels 31–16) | | eDMA Hardware Request Status (EDMA_B_HRSL, Channels 15–00) | |
| 0xFFFF5_4038 – 0xFFFF5_40FC | Reserved | | | |
| 0xFFFF5_4100 | eDMA Channel 0 Priority (EDMA_B_CPR0) | eDMA Channel 1 Priority (EDMA_B_CPR1) | eDMA Channel 2 Priority (EDMA_B_CPR2) | eDMA Channel 3 Priority (EDMA_B_CPR3) |
| 0xFFFF5_4104 | eDMA Channel 4 Priority (EDMA_B_CPR4) | eDMA Channel 5 Priority (EDMA_B_CPR5) | eDMA Channel 6 Priority (EDMA_B_CPR6) | eDMA Channel 7 Priority (EDMA_B_CPR7) |
| 0xFFFF5_4108 | eDMA Channel 8 Priority (EDMA_B_CPR8) | eDMA Channel 9 Priority (EDMA_B_CPR9) | eDMA Channel 10 Priority (EDMA_B_CPR10) | eDMA Channel 11 Priority (EDMA_B_CPR11) |
| 0xFFFF5_410C | eDMA Channel 12 Priority (EDMA_B_CPR12) | eDMA Channel 13 Priority (EDMA_B_CPR13) | eDMA Channel 14 Priority (EDMA_B_CPR14) | eDMA Channel 15 Priority (EDMA_B_CPR15) |
| 0xFFFF5_4110 | eDMA Channel 16 Priority (EDMA_B_CPR16) | eDMA Channel 17 Priority (EDMA_B_CPR17) | eDMA Channel 18 Priority (EDMA_B_CPR18) | eDMA Channel 19 Priority (EDMA_B_CPR19) |
| 0xFFFF5_4114 | eDMA Channel 20 Priority (EDMA_B_CPR20) | eDMA Channel 21 Priority (EDMA_B_CPR21) | eDMA Channel 22 Priority (EDMA_B_CPR22) | eDMA Channel 23 Priority (EDMA_B_CPR23) |
| 0xFFFF5_4118 | eDMA Channel 24 Priority (EDMA_B_CPR24) | eDMA Channel 25 Priority (EDMA_B_CPR25) | eDMA Channel 26 Priority (EDMA_B_CPR26) | eDMA Channel 27 Priority (EDMA_B_CPR27) |

Table 21-3. eDMA_B 32-bit Memory Map—Graphical View (continued)

| Address | Register | | | |
|--------------------------------|---------------------------|---|---|---|
| | 0xFFFF5_411C | eDMA Channel 28 Priority (EDMA_B_CPR28) | eDMA Channel 29 Priority (EDMA_B_CPR29) | eDMA Channel 30 Priority (EDMA_B_CPR30) |
| 0xFFFF5_4120 – 0xFFFF5_4FFF | Reserved | | | |
| 0xFFFF5_5000 – 0xFFFF5_51FC | EDMA_B_TCD00–EDMA_B_TCD15 | | | |
| 0xFFFF5_5200 – 0xFFFF5_53FC | EDMA_B_TCD16–EDMA_B_TCD31 | | | |
| 0xFFFF5_5300 | Reserved | | | |

21.3.2 Register Descriptions

NOTE

Any reference to EDMA_A_[register_name] should be ignored when using eDMA_B. That register does not exist in eDMA_B. Registers that exist in both eDMA_A and eDMA_B are indicated with a register name of format EDMA_x_[register_name].

This section lists the eDMA registers in address order and describes the registers and their bit fields.

Reading reserved bits in a register returns the value of zero. Writes to reserved bits in a register are ignored. Reading or writing to a reserved memory location generates a bus error.

Many of the control registers have a bit width that matches the number of channels implemented in the module:

- 64 bits for eDMA_A (made up of two 32-bit registers: high and low—for example EDMA_A_ERQRH has upper 32 channels of eDMA_A)
- 32 bits for eDMA_B

21.3.2.1 eDMA Control Register (EDMA_x_MCR)

The 32-bit EDMA_x_MCR defines the basic operating configuration of the eDMA.

The eDMA arbitrates channel service requests in two (eDMA_B) or four (eDMA_A) groups (0, 1, 2, 3) of 16 channels each:

- Group 0 contains channels 0–15
- Group 1 contains channels 16–31
- Group 2 contains channels 32–47 (eDMA_A only)
- Group 3 contains channels 48–63 (eDMA_A only)

Arbitration within a group can be configured to use a fixed priority or a round robin. In fixed-priority arbitration, the highest priority channel requesting service is selected to execute. The priorities are

assigned by the channel priority registers. See [Section 21.3.2.17, eDMA Channel n Priority Registers \(EDMA_x_CPRn\)](#). In round-robin arbitration mode, the channel priorities are ignored and the channels within each group are cycled through, from channel 15 down to channel 0, without regard to priority.

The group priorities operate in a similar fashion. In group fixed-priority arbitration mode, channel service requests in the highest priority group are executed first where priority level 3 (eDMA_A) or 1 (eDMA_B) is the highest and priority level 0 is the lowest. The group priorities are assigned in the GRPnPRI fields of the eDMA control register (EDMA_x_MCR). All group priorities must have unique values prior to any channel service requests occur, otherwise a configuration error is reported. In group round-robin mode, the group priorities are ignored and the groups are cycled through, from group 3 (eDMA_A) or 1 (eDMA_B) down to group 0, without regard to priority.

Minor loop offsets are address offset values added to the final source address (SADDR) or destination address (DADDR) upon minor loop completion. When minor loop offsets are enabled, the minor loop offset (MLOFF) is added to the final source address (SADDR) or to the final destination address (DADDR) or to both addresses prior to the addresses being written back into the TCD. If the major loop is complete, the minor loop offset is ignored and the major loop address offsets (SLAST and DLAST_SGA) are used to compute the next EDMA_x_TCD.SADDR and EDMA_x_TCD.DADDR values.

When minor loop mapping is enabled (EDMA_x_MCR[EMLM] = 1), TCDn word2 is redefined. A portion of TCDn word2 is used to specify multiple fields: a source enable bit (SMLOE) to specify that the minor loop offset should be applied to the source address (SADDR) upon minor loop completion, a destination enable bit (DMLOE) to specify the minor loop offset should be applied to the destination address (DADDR) upon minor loop completion, and the sign extended minor loop offset value (MLOFF). The same offset value (MLOFF) is used for both source and destination minor loop offsets.

When either of the minor loop offsets is enabled (SMLOE is set or DMLOE is set), the NBYTES field is reduced to 10 bits. When both minor loop offsets are disabled (SMLOE is cleared and DMLOE is cleared), the NBYTES field becomes a 30-bit vector.

When minor loop mapping is disabled (EDMA_x_MCR[EMLM] = 0), all 32 bits of TCDn word2 are assigned to the NBYTES field. See [Section 21.3.2.18, Transfer Control Descriptor \(TCD\)](#), for more details.

Offset: EDMA_A_BASE + 0x0000

Access: User read/write

| | | | | | | | | | | | | | | | | |
|-------|---------|----|---------|----|---------|----|---------|----|------|-----|------|-----|------|------|------|-----|
| | 0 | 1 | 2 | 3 | 4 | 5 | 6 | 7 | 8 | 9 | 10 | 11 | 12 | 13 | 14 | 15 |
| R | 0 | 0 | 0 | 0 | 0 | 0 | 0 | 0 | 0 | 0 | 0 | 0 | 0 | 0 | | |
| W | | | | | | | | | | | | | | | CXFR | ECX |
| Reset | 0 | 0 | 0 | 0 | 0 | 0 | 0 | 0 | 0 | 0 | 0 | 0 | 0 | 0 | 0 | 0 |
| | 16 | 17 | 18 | 19 | 20 | 21 | 22 | 23 | 24 | 25 | 26 | 27 | 28 | 29 | 30 | 31 |
| R | GRP3PRI | | GRP2PRI | | GRP1PRI | | GRP0PRI | | EMLM | CLM | HALT | HOE | ERGA | ERCA | EDBG | 0 |
| W | | | | | | | | | | | | | | | | |
| Reset | 1 | 1 | 1 | 0 | 0 | 1 | 0 | 0 | 0 | 0 | 0 | 0 | 0 | 0 | 0 | 0 |

Figure 21-2. eDMA Control Register (EDMA_A_CR)

Offset: EDMA_B_BASE + 0x0000

Access: User read/write

| | | | | | | | | | | | | | | | | |
|-------|----|----|----|----|----|----------|----|----------|------|-----|------|-----|------|------|------|-----|
| | 0 | 1 | 2 | 3 | 4 | 5 | 6 | 7 | 8 | 9 | 10 | 11 | 12 | 13 | 14 | 15 |
| R | 0 | 0 | 0 | 0 | 0 | 0 | 0 | 0 | 0 | 0 | 0 | 0 | 0 | 0 | | |
| W | | | | | | | | | | | | | | | CXFR | ECX |
| Reset | 0 | 0 | 0 | 0 | 0 | 0 | 0 | 0 | 0 | 0 | 0 | 0 | 0 | 0 | 0 | 0 |
| | 16 | 17 | 18 | 19 | 20 | 21 | 22 | 23 | 24 | 25 | 26 | 27 | 28 | 29 | 30 | 31 |
| R | 0 | 0 | 0 | 0 | 0 | GRP1 PRI | 0 | GRP0 PRI | EMLM | CLM | HALT | HOE | ERGA | ERCA | EDBG | 0 |
| W | | | | | | | | | | | | | | | | |
| Reset | 0 | 0 | 0 | 0 | 0 | 1 | 0 | 0 | 0 | 0 | 0 | 0 | 0 | 0 | 0 | 0 |

Figure 21-3. eDMA Control Register (EDMA_B_CR)

Table 21-4. EDMA_A_MCR Field Descriptions

| Field | Description |
|------------|---|
| 0–13 | Reserved |
| 14 CXFR | Cancel Transfer. 0 Normal operation. 1 Cancel the remaining data transfer. Stop the executing channel and force the minor loop to be finished. The cancel takes effect after the last write of the current read/write sequence. The CXFR bit clears itself after the cancel has been honored. This cancel retires the channel normally as if the minor loop was completed. |
| 15 ECX | Error cancel transfer. 0 Normal operation. 1 Cancel the remaining data transfer in the same fashion as the CXFR cancel transfer. Stop the executing channel and force the minor loop to be finished. The cancel takes effect after the last write of the current read/write sequence. The ECX bit clears itself after the cancel has been honored. In addition to cancelling the transfer, the ECX treats the cancel as an error condition; thus updating the EDMA_x_ESR register and generating an optional error interrupt. See Section 21.3.2.2, eDMA Error Status Register (EDMA_x_ESR) . |

Table 21-4. EDMA_A_MCR Field Descriptions (continued)

| Field | Description |
|------------------|--|
| 16–17 GRP3PRI | Channel group 3 priority. Group 3 priority level when fixed priority group arbitration is enabled. |
| 18–19 GRP2PRI | Channel group 2 priority. Group 2 priority level when fixed priority group arbitration is enabled. |
| 20–21 GRP1PRI | Channel group 1 priority. Group 1 priority level when fixed priority group arbitration is enabled. |
| 22–23 GRP0PRI | Channel group 0 priority. Group 0 priority level when fixed priority group arbitration is enabled. |
| 24 EMLM | Enable minor loop mapping. 0 Minor loop mapping disabled. TCD Word 2 is defined as a 32-bit nbytes field. 1 Minor loop mapping enabled. When set, TCD n Word 2 is redefined to include individual enable fields, an offset field and the NBYTES field. The individual enable fields allow the minor loop offset to be applied to the source address, the destination address, or both. The NBYTES field is reduced when either offset is enabled. |
| 25 CLM | Continuous link mode. 0 A minor loop channel link made to itself goes through channel arbitration before being activated again. 1 A minor loop channel link made to itself does not go through channel arbitration before being activated again. Upon minor loop completion, the channel is active again if that channel has a minor loop channel link enabled and the link channel is itself. This effectively applies the minor loop offsets and restarts the next minor loop. |
| 26 HALT | Halt DMA operations. 0 Normal operation. 1 Stall the start of any new channels. Executing channels are allowed to complete. Channel execution resumes when the HALT bit is cleared. |
| 27 HOE | Halt on error. 0 Normal operation. 1 Any error causes the HALT bit to be set. Subsequently, all service requests are ignored until the HALT bit is cleared. |
| 28 ERGA | Enable round-robin group arbitration. 0 Fixed-priority arbitration is used for selection among the groups. 1 Round-robin arbitration is used for selection among the groups. |
| 29 ERCA | Enable Round-Robin Channel Arbitration. 0 Fixed-priority arbitration is used for channel selection within each group. 1 Round-robin arbitration is used for channel selection within each group. |
| 30 EDBG | Enable Debug. 0 The assertion of the system debug control input is ignored. 1 The assertion of the system debug control input causes the eDMA to stall the start of a new channel. Executing channels are allowed to complete. Channel execution resumes when either the system debug control input is negated or the EDBG bit is cleared. |
| 31 | Reserved |

21.3.2.2 eDMA Error Status Register (EDMA_x_ESR)

The EDMA_x_ESR provides information about the last recorded channel error. Channel errors can be caused by a configuration error (an illegal setting in the transfer control descriptor or an illegal priority register setting in fixed-arbitration mode) or an error termination to a bus master read or write cycle.

A configuration error is caused when the starting source or destination address, source or destination offsets, minor loop byte count, and the transfer size represent an inconsistent state. The addresses and offsets must be aligned on 0-modulo-transfer_size boundaries, and the minor loop byte count must be a multiple of the source and destination transfer sizes. All source reads and destination writes must be configured to the natural boundary of the programmed transfer size respectively.

In fixed-arbitration mode, a configuration error is generated when any two channel priority levels are equal and any channel is activated. The ERRCHN field is undefined for this type of error. All channel priority levels must be unique before any service requests are made.

If a scatter-gather operation is enabled on channel completion, a configuration error is reported if the scatter-gather address (DLAST_SGA) is not aligned on a 32-byte boundary. If minor loop channel linking is enabled on channel completion, a configuration error is reported when the link is attempted if the EDMA_x_TCD.CITER.E_LINK bit is not equal to the EDMA_x_TCD.BITER.E_LINK bit. All configuration error conditions except scatter-gather and minor loop link error are reported as the channel is activated and assert an error interrupt request if enabled. When properly enabled, a scatter-gather configuration error is reported when the scatter-gather operation begins at major loop completion. A minor loop channel link configuration error is reported when the link operation is serviced at minor loop completion.

If a system bus read or write is terminated with an error, the data transfer is immediately stopped and the appropriate bus error flag is set. In this case, the state of the channel's transfer control descriptor is updated by the DMA engine with the current source address, destination address, and minor loop byte count at the point of the fault. If a bus error occurs on the last read prior to beginning the write sequence, the write is executed using the data captured during the bus error. If a bus error occurs on the last write prior to switching to the next read sequence, the read sequence is executed before the channel is terminated due to the destination bus error.

A transfer may be cancelled by software via the EDMA_x_MCR[CX] bit. When a cancel transfer request is recognized, the eDMA engine stops processing the channel. The current read-write sequence is allowed to finish. If the cancel occurs on the last read-write sequence of a major or minor loop, the cancel request is discarded and the channel retires normally.

The error cancel transfer is the same as a cancel transfer except the DMAES register is updated with the cancelled channel number and error cancel bit is set. The TCD of a cancelled channel has the source address and destination address of the last transfer saved in the TCD. It is the responsibility of the user to initialize the TCD again should the channel need to be restarted because the aforementioned fields have been modified by the eDMA engine and no longer represent the original parameters. When a transfer is cancelled via the error cancel transfer mechanism (setting the EDMA_x_MCR[ECX]), the channel number is loaded into the EDMA_x_ESR[ERRCHN] field and the EDMA_x_ESR[ECX] and EDMA_x_ESR[VLD] bits are set. In addition, an error interrupt may be generated if enabled. Refer to [Section 21.3.2.14, eDMA Error Registers \(EDMA_x_ERH, EDMA_x_ERL\)](#).

The occurrence of any type of error causes the DMA engine to stop the active channel and the appropriate channel bit in the eDMA error register to be asserted. At the same time, the details of the error condition are loaded into the EDMA_x_ESR. The major loop complete indicators, setting the transfer control descriptor DONE flag and the possible assertion of an interrupt request, are not affected when an error is detected. After the error status has been updated, the DMA engine continues to operate by servicing the next appropriate channel. A channel that experiences an error condition is not automatically disabled. If a channel is terminated by an error and then issues another service request before the error is fixed, that channel will execute and terminate with the same error condition.

Offset: EDMA_x_BASE + 0x0004

Access: User read-only

| | | | | | | | | | | | | | | | | |
|-------|-----|-----|--------|----|----|----|-----|-----|-----|-----|-----|-----|-----|-----|----|-----|
| | 0 | 1 | 2 | 3 | 4 | 5 | 6 | 7 | 8 | 9 | 10 | 11 | 12 | 13 | 14 | 15 |
| R | VLD | 0 | 0 | 0 | 0 | 0 | 0 | 0 | 0 | 0 | 0 | 0 | 0 | 0 | 0 | ECX |
| W | | | | | | | | | | | | | | | | |
| Reset | 0 | 0 | 0 | 0 | 0 | 0 | 0 | 0 | 0 | 0 | 0 | 0 | 0 | 0 | 0 | 0 |
| | 16 | 17 | 18 | 19 | 20 | 21 | 22 | 23 | 24 | 25 | 26 | 27 | 28 | 29 | 30 | 31 |
| R | GPE | CPE | ERRCHN | | | | SAE | SOE | DAE | DOE | NCE | SGE | SBE | DBE | | |
| W | | | | | | | | | | | | | | | | |
| Reset | 0 | 0 | 0 | 0 | 0 | 0 | 0 | 0 | 0 | 0 | 0 | 0 | 0 | 0 | 0 | 0 |

Figure 21-4. eDMA Error Status Register (EDMA_x_ESR)

Table 21-5. EDMA_x_ESR Field Descriptions

| Field | Description |
|-----------------|--|
| 0 VLD | Valid Bit. Logical OR of all EDMA_x_ERL status bits. 0 No EDMA_x_ER bits are set. 1 At least one EDMA_x_ER bit is set indicating a valid error exists that has not been cleared. |
| 1–14 | Reserved |
| 15 ECX | Transfer canceled. 0 No canceled transfers. 1 The last recorded entry was a canceled transfer via the error cancel transfer input. |
| 16 GPE | Group-priority error. 0 No group-priority error. 1 The last recorded error was a configuration error among the group priorities indicating not all group priorities are unique. |
| 17 CPE | Channel-Priority Error. 0 No channel-priority error. 1 The last recorded error was a configuration error in the channel priorities within a group, indicating not all channel priorities within a group are unique. |
| 18–23 ERRCHN | Error Channel Number or Canceled Channel Number. Channel number of the last recorded error (excluding GPE and CPE errors) or last recorded transfer that was error cancelled. Note: Do not rely on the number in the ERRCHN field group for channel-priority errors. Group- and Channel-priority errors must be resolved by inspection. The application code must interrogate the priority registers to find groups or channels with duplicate priority level. |

Table 21-5. EDMA_x_ESR Field Descriptions (continued)

| Field | Description |
|-----------|---|
| 24 SAE | Source Address Error. 0 No source address configuration error. 1 The last recorded error was a configuration error detected in the EDMA_x_TCD.SADDR field, indicating EDMA_x_TCD.SADDR is inconsistent with EDMA_x_TCD.SSIZE. |
| 25 SOE | Source Offset Error. 0 No source offset configuration error. 1 The last recorded error was a configuration error detected in the EDMA_x_TCD.SOFF field, indicating EDMA_x_TCD.SOFF is inconsistent with EDMA_x_TCD.SSIZE. |
| 26 DAE | Destination Address Error. 0 No destination address configuration error. 1 The last recorded error was a configuration error detected in the EDMA_x_TCD.DADDR field, indicating EDMA_x_TCD.DADDR is inconsistent with EDMA_x_TCD.DSIZE. |
| 27 DOE | Destination Offset Error. 0 No destination offset configuration error. 1 The last recorded error was a configuration error detected in the EDMA_x_TCD.DOFF field, indicating EDMA_x_TCD.DOFF is inconsistent with EDMA_x_TCD.DSIZE. |
| 28 NCE | NBYTES/CITER Configuration Error. 0 No NBYTES/CITER configuration error. 1 The last recorded error was a configuration error detected in the EDMA_x_TCD.NBYTES or EDMA_x_TCD.CITER fields, indicating the following conditions exist: <ul style="list-style-type: none"> • EDMA_x_TCD.NBYTES is not a multiple of EDMA_x_TCD.SSIZE and EDMA_x_TCD.DSIZE, or • EDMA_x_TCD.CITER is equal to zero, or • EDMA_x_TCD.CITER.E_LINK is not equal to EDMA_x_TCD.BITER.E_LINK. |
| 29 SGE | Scatter-Gather Configuration Error. 0 No scatter-gather configuration error. 1 The last recorded error was a configuration error detected in the EDMA_x_TCD.DLAST_SGA field, indicating EDMA_x_TCD.DLAST_SGA is not on a 32-byte boundary. This field is checked at the beginning of a scatter-gather operation after major loop completion if EDMA_x_TCD.E_SG is enabled. |
| 30 SBE | Source Bus Error. 0 No source bus error. 1 The last recorded error was a bus error on a source read. |
| 31 DBE | Destination Bus Error. 0 No destination bus error. 1 The last recorded error was a bus error on a destination write. |

21.3.2.3 eDMA Enable Request Registers (EDMA_A_ERQRH, EDMA_x_ERQRL)

NOTE

Any reference to EDMA_A_[register_name] should be ignored when using eDMA_B. That register does not exist in eDMA_B. Registers that exist in both eDMA_A and eDMA_B are indicated with a register name of format EDMA_x_[register_name].

The EDMA_A_ERQRH and EDMA_x_ERQRL provide a bit map for the 32 (or 64 for eDMA_A) channels to enable the request signal for each channel. EDMA_A_ERQRH supports channels 63–32, while EDMA_x_ERQRL covers channels 31–0.

Enhanced Direct Memory Access Controller (eDMA)

The state of any given channel enable is directly affected by writes to these registers; the state is also affected by writes to the EDMA_x_SERQR and EDMA_x_CERQR. The EDMA_Ax_CERQR and EDMA_x_SERQR are provided so that the request enable for a single channel can be modified without performing a read-modify-write sequence to the EDMA_A_ERQRH and EDMA_x_ERQRL.

Both the eDMA request input signal and this enable request flag must be asserted before a channel's hardware service request is accepted. The state of the eDMA enable request flag does not effect a channel service request made through software or a linked channel request.

Address: EDMA_A_BASE + 0x0008

Access: User R/W

| | | | | | | | | | | | | | | | | |
|-------|-----|-----|-----|-----|-----|-----|-----|-----|-----|-----|-----|-----|-----|-----|-----|-----|
| | 0 | 1 | 2 | 3 | 4 | 5 | 6 | 7 | 8 | 9 | 10 | 11 | 12 | 13 | 14 | 15 |
| R | ERQ | ERQ | ERQ | ERQ | ERQ | ERQ | ERQ | ERQ | ERQ | ERQ | ERQ | ERQ | ERQ | ERQ | ERQ | ERQ |
| W | 63 | 62 | 61 | 60 | 59 | 58 | 57 | 56 | 55 | 54 | 53 | 52 | 51 | 50 | 49 | 48 |
| Reset | 0 | 0 | 0 | 0 | 0 | 0 | 0 | 0 | 0 | 0 | 0 | 0 | 0 | 0 | 0 | 0 |
| | 16 | 17 | 18 | 19 | 20 | 21 | 22 | 23 | 24 | 25 | 26 | 27 | 28 | 29 | 30 | 31 |
| R | ERQ | ERQ | ERQ | ERQ | ERQ | ERQ | ERQ | ERQ | ERQ | ERQ | ERQ | ERQ | ERQ | ERQ | ERQ | ERQ |
| W | 47 | 46 | 45 | 44 | 43 | 42 | 41 | 40 | 39 | 38 | 37 | 36 | 35 | 34 | 33 | 32 |
| Reset | 0 | 0 | 0 | 0 | 0 | 0 | 0 | 0 | 0 | 0 | 0 | 0 | 0 | 0 | 0 | 0 |

Figure 21-5. eDMA Enable Request High Register (EDMA_A_ERQRH)

Offset: EDMA_x_BASE + 0x000C

Access: User read/write

| | | | | | | | | | | | | | | | | |
|-------|-----|-----|-----|-----|-----|-----|-----|-----|-----|-----|-----|-----|-----|-----|-----|-----|
| | 0 | 1 | 2 | 3 | 4 | 5 | 6 | 7 | 8 | 9 | 10 | 11 | 12 | 13 | 14 | 15 |
| R | ERQ | ERQ | ERQ | ERQ | ERQ | ERQ | ERQ | ERQ | ERQ | ERQ | ERQ | ERQ | ERQ | ERQ | ERQ | ERQ |
| W | 31 | 30 | 29 | 28 | 27 | 26 | 25 | 24 | 23 | 22 | 21 | 20 | 19 | 18 | 17 | 16 |
| Reset | 0 | 0 | 0 | 0 | 0 | 0 | 0 | 0 | 0 | 0 | 0 | 0 | 0 | 0 | 0 | 0 |
| | 16 | 17 | 19 | 19 | 20 | 21 | 22 | 23 | 24 | 25 | 26 | 27 | 28 | 29 | 30 | 31 |
| R | ERQ | ERQ | ERQ | ERQ | ERQ | ERQ | ERQ | ERQ | ERQ | ERQ | ERQ | ERQ | ERQ | ERQ | ERQ | ERQ |
| W | 15 | 14 | 13 | 12 | 11 | 10 | 09 | 08 | 07 | 06 | 05 | 04 | 03 | 02 | 01 | 00 |
| Reset | 0 | 0 | 0 | 0 | 0 | 0 | 0 | 0 | 0 | 0 | 0 | 0 | 0 | 0 | 0 | 0 |

Figure 21-6. eDMA Enable Request Register (EDMA_x_ERQRL)

Table 21-6. EDMA_x_ERQRL Field Descriptions

| Field | Description |
|--------------------------|--|
| 0–31 ERQ _n | Enable eDMA Hardware Service Request <i>n</i> . 0 The eDMA request signal for channel <i>n</i> is disabled. 1 The eDMA request signal for channel <i>n</i> is enabled. |

As a given channel completes processing its major iteration count, there is a flag in the transfer control descriptor that may affect the ending state of the EDMA_x_ERQR bit for that channel. If the

EDMA_x_TCD.D_REQ bit is set, then the corresponding EDMA_x_ERQR bit is cleared after the major loop is complete, disabling the eDMA hardware request. Otherwise if the D_REQ bit is cleared, the state of the EDMA_x_ERQR bit is unaffected.

21.3.2.4 eDMA Enable Error Interrupt Registers (EDMA_A_EEIRH, EDMA_x_EEIRL)

NOTE

Any reference to EDMA_A_[register_name] should be ignored when using eDMA_B. That register does not exist in eDMA_B. Registers that exist in both eDMA_A and eDMA_B are indicated with a register name of format EDMA_x_[register_name].

The EDMA_A_EEIRH and EDMA_x_EEIRL provide a bit map for the 32 (or 64 for eDMA_A) channels to enable the error interrupt signal for each channel. EDMA_A_EEIRH supports channels 63–32, while EDMA_x_EEIRL covers channels 31–0.

The state of any given channel's error interrupt enable is directly affected by writes to these registers; it is also affected by writes to the EDMA_x_SEEIR and EDMA_x_CEEIR. The EDMA_x_SEEIR and EDMA_x_CEEIR are provided so that the error interrupt enable for a single channel can be modified without the performing a read-modify-write sequence to the EDMA_A_EEIRH and EDMA_x_EEIRL.

Both the eDMA error indicator and this error interrupt enable flag must be asserted before an error interrupt request for a given channel is asserted.

Address: EDMA_A_BASE + 0x0010

Access: User read/write

| | 0 | 1 | 2 | 3 | 4 | 5 | 6 | 7 | 8 | 9 | 10 | 11 | 12 | 13 | 14 | 15 |
|-------|-----|-----|-----|-----|-----|-----|-----|-----|-----|-----|-----|-----|-----|-----|-----|-----|
| R | EEI | EEI | EEI | EEI | EEI | EEI | EEI | EEI | EEI | EEI | EEI | EEI | EEI | EEI | EEI | EEI |
| W | 63 | 62 | 61 | 60 | 59 | 58 | 57 | 56 | 55 | 54 | 53 | 52 | 51 | 50 | 49 | 48 |
| Reset | 0 | 0 | 0 | 0 | 0 | 0 | 0 | 0 | 0 | 0 | 0 | 0 | 0 | 0 | 0 | 0 |

| | 16 | 17 | 18 | 19 | 20 | 21 | 22 | 23 | 24 | 25 | 26 | 27 | 28 | 29 | 30 | 31 |
|-------|-----|-----|-----|-----|-----|-----|-----|-----|-----|-----|-----|-----|-----|-----|-----|-----|
| R | EEI | EEI | EEI | EEI | EEI | EEI | EEI | EEI | EEI | EEI | EEI | EEI | EEI | EEI | EEI | EEI |
| W | 47 | 46 | 45 | 44 | 43 | 42 | 41 | 40 | 39 | 38 | 37 | 36 | 35 | 34 | 33 | 32 |
| Reset | 0 | 0 | 0 | 0 | 0 | 0 | 0 | 0 | 0 | 0 | 0 | 0 | 0 | 0 | 0 | 0 |

Figure 21-7. eDMA Enable Error Interrupt High Register (EDMA_A_EEIRH)

Address: EDMA_x_BASE + 0x0014

Access: User R/W

| | | | | | | | | | | | | | | | | |
|-------|-----|-----|-----|-----|-----|-----|-----|-----|-----|-----|-----|-----|-----|-----|-----|-----|
| | 0 | 1 | 2 | 3 | 4 | 5 | 6 | 7 | 8 | 9 | 10 | 11 | 12 | 13 | 14 | 15 |
| R | EEI | EEI | EEI | EEI | EEI | EEI | EEI | EEI | EEI | EEI | EEI | EEI | EEI | EEI | EEI | EEI |
| W | 31 | 30 | 29 | 28 | 27 | 26 | 25 | 24 | 23 | 22 | 21 | 20 | 19 | 18 | 17 | 16 |
| Reset | 0 | 0 | 0 | 0 | 0 | 0 | 0 | 0 | 0 | 0 | 0 | 0 | 0 | 0 | 0 | 0 |

| | | | | | | | | | | | | | | | | |
|-------|-----|-----|-----|-----|-----|-----|-----|-----|-----|-----|-----|-----|-----|-----|-----|-----|
| | 16 | 17 | 18 | 19 | 20 | 21 | 22 | 23 | 24 | 25 | 26 | 27 | 28 | 29 | 30 | 31 |
| R | EEI | EEI | EEI | EEI | EEI | EEI | EEI | EEI | EEI | EEI | EEI | EEI | EEI | EEI | EEI | EEI |
| W | 15 | 14 | 13 | 12 | 11 | 10 | 09 | 08 | 07 | 06 | 05 | 04 | 03 | 02 | 01 | 00 |
| Reset | 0 | 0 | 0 | 0 | 0 | 0 | 0 | 0 | 0 | 0 | 0 | 0 | 0 | 0 | 0 | 0 |

Figure 21-8. eDMA Enable Error Interrupt Low Register (EDMA_x_EEIRL)

Table 21-7. EDMA_x_EEIRL Field Descriptions

| Field | Description |
|--------------|---|
| 0–31 EEIn | Enable Error Interrupt <i>n</i> . 0 The error signal for channel <i>n</i> does not generate an error interrupt. 1 The assertion of the error signal for channel <i>n</i> generate an error interrupt request. |

21.3.2.5 eDMA Set Enable Request Register (EDMA_x_SERQR)

NOTE

Any reference to EDMA_A_[register_name] should be ignored when using eDMA_B. That register does not exist in eDMA_B. Registers that exist in both eDMA_A and eDMA_B are indicated with a register name of format EDMA_x_[register_name].

The EDMA_x_SERQR provides a simple memory-mapped mechanism to set a given bit in the EDMA_A_ERQRH or EDMA_x_ERQRL to enable the eDMA request for a given channel. The data value on a register write causes the corresponding bit in the EDMA_A_ERQRH or EDMA_x_ERQRL to be set. Setting bit 1 (SERQ[0]) provides a global set function, forcing the entire contents of EDMA_A_ERQRH and EDMA_x_ERQRL to be asserted. Reads of this register return all zeroes.

If bit 0 is set, the SERQ command is ignored. This allows multiple byte registers to be written as a 32-bit word. Reads of this register return all zeroes.

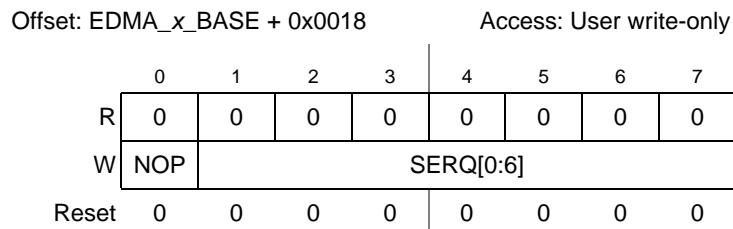

Figure 21-9. eDMA Set Enable Request Register (EDMA_x_SERQR)

Table 21-8. EDMA_x_SERQR Field Descriptions

| Field | Descriptions |
|-------------|--|
| 0 NOP | No operation. 0 Normal operation. 1 No operation, ignore bits 1–7. |
| 1–7 SERQ | Set Enable Request. 0–31 (63 for eDMA_A) Set corresponding bit in EDMA_A_ERQRH or EDMA_x_ERQRL. 64–127 Set all bits in EDMA_A_ERQRH and EDMA_x_ERQRL. Bit 2 (SERQR[1]) is not used on eDMA_B. |

21.3.2.6 eDMA Clear Enable Request Register (EDMA_x_CERQR)

NOTE

Any reference to EDMA_A_[register_name] should be ignored when using eDMA_B. That register does not exist in eDMA_B. Registers that exist in both eDMA_A and eDMA_B are indicated with a register name of format EDMA_x_[register_name].

The EDMA_x_CERQR provides a simple memory-mapped mechanism to clear a given bit in the EDMA_A_ERQRH or EDMA_x_ERQRL to disable the DMA request for a given channel. The data value on a register write causes the corresponding bit in the EDMA_A_ERQRH or EDMA_x_ERQRL to be cleared. Setting bit 1 (CERQ[0]) provides a global clear function, forcing the entire contents of EDMA_A_ERQRH and EDMA_x_ERQRL to be zeroed, disabling all eDMA request inputs. Reads of this register return all zeroes.

If bit 0 is set, the CERQ command is ignored. This allows multiple byte registers to be written as a 32-bit word. Reads of this register return all zeroes.

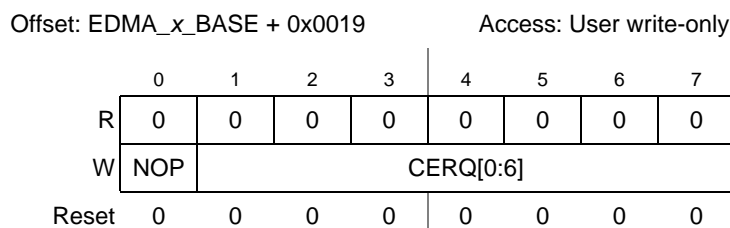

Figure 21-10. eDMA Clear Enable Request Register (EDMA_x_CERQR)

Table 21-9. EDMA_x_CERQR Field Descriptions

| Field | Description |
|-------------|--|
| 0 NOP | No operation. 0 Normal operation. 1 No operation, ignore bits 1–7. |
| 1–7 CERQ | Clear Enable Request. 0–31 (63 for eDMA_A) Clear corresponding bit in EDMA_A_ERQRH or EDMA_x_ERQRL. 64–127 Clear all bits in EDMA_A_ERQRH and EDMA_x_ERQRL. Bit 2 (CERQR[1]) is not used on eDMA_B. |

21.3.2.7 eDMA Set Enable Error Interrupt Register (EDMA_x_SEEIR)

NOTE

Any reference to EDMA_A_[register_name] should be ignored when using eDMA_B. That register does not exist in eDMA_B. Registers that exist in both eDMA_A and eDMA_B are indicated with a register name of format EDMA_x_[register_name].

The EDMA_x_SEEIR provides a memory-mapped mechanism to set a given bit in the EDMA_A_EEIRH or EDMA_x_EEIRL to enable the error interrupt for a given channel. The data value on a register write causes the corresponding bit in the EDMA_A_EEIRH or EDMA_x_EEIRL to be set. Setting bit 1 (SEEI[0]) provides a global set function, forcing the entire contents of EDMA_A_EEIRH or EDMA_x_EEIRL to be asserted. Reads of this register return all zeroes.

If bit 0 is set, the SEEI command is ignored. This allows multiple byte registers to be written as a 32-bit word. Reads of this register return all zeroes.

| | | | | | | | | |
|------------------------------|-----|---|---|-------------------------|---|---|---|---|
| Offset: EDMA_x_BASE + 0x001A | | | | Access: User write-only | | | | |
| | 0 | 1 | 2 | 3 | 4 | 5 | 6 | 7 |
| R | 0 | 0 | 0 | 0 | 0 | 0 | 0 | 0 |
| W | NOP | | | SEEI[0:6] | | | | |
| Reset | 0 | 0 | 0 | 0 | 0 | 0 | 0 | 0 |

Figure 21-11. eDMA Set Enable Error Interrupt Register (EDMA_x_SEEIR)

Table 21-10. EDMA_x_SEEIR Field Descriptions

| Field | Description |
|------------------|--|
| 0 NOP | No operation. 0 Normal operation. 1 No operation, ignore bits 1–7. |
| 1–7 SEEI[0:6] | Set Enable Error Interrupt. 0–31 (63 for eDMA_A) Set corresponding bit in EDMA_A_EIRRH or EDMA_x_EIRRL. 64–127 Set all bits in EDMA_A_EIRRH or EDMA_x_EEIRL. Bit 2(SEEIR[1]) is not used on eDMA_B. |

21.3.2.8 eDMA Clear Enable Error Interrupt Register (EDMA_x_CEEIR)

The EDMA_x_CEEIR provides a memory-mapped mechanism to clear a given bit in the EDMA_A_EEIRH or EDMA_x_EEIRL to disable the error interrupt for a given channel. The data value on a register write causes the corresponding bit in the EDMA_A_EEIRH or EDMA_x_EEIRL to be cleared. Setting bit 1 (CEEI[0]) provides a global clear function, forcing the entire contents of the EDMA_A_EEIRH or EDMA_x_EEIRL to be zeroed, disabling error interrupts for all channels. Reads of this register return all zeroes.

If bit 0 is set, the CEEI command is ignored. This allows multiple byte registers to be written as a 32-bit word. Reads of this register return all zeroes.

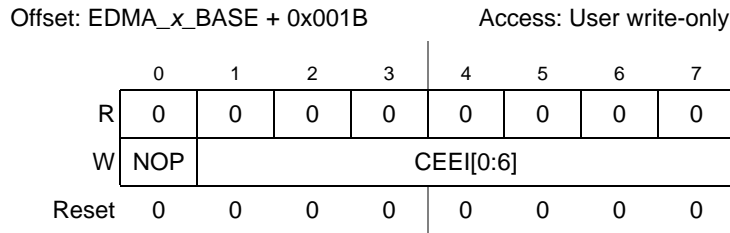

Figure 21-12. eDMA Clear Enable Error Interrupt Register (EDMA_x_CEEIR)

Table 21-11. EDMA_x_CEEIR Field Descriptions

| Field | Description |
|-------------|---|
| 0 NOP | No operation. 0 Normal operation. 1 No operation, ignore bits 1-7. |
| 1-7 CEEI | Clear Enable Error Interrupt. 0-31 (63 for eDMA_A) Clear corresponding bit in EDMA_A_EEIRH or EDMA_x_EEIRL. 64-127 Clear all bits in EDMA_A_EEIRH or EDMA_x_EEIRL. Bit 2 (CEEIR[1]) is not used on eDMA_B. |

21.3.2.9 eDMA Clear Interrupt Request Register (EDMA_x_CIRQR)

The EDMA_x_CIRQR provides a memory-mapped mechanism to clear a given bit in the EDMA_A_IRQRH or EDMA_x_IRQRL to disable the interrupt request for a given channel. The given value on a register write causes the corresponding bit in the EDMA_A_IRQRH or EDMA_x_IRQRL to be cleared. Setting bit 1 (CINT[0]) provides a global clear function, forcing the entire contents of the EDMA_A_IRQRH or EDMA_x_IRQRL to be zeroed, disabling all eDMA interrupt requests. Reads of this register return all zeroes.

If bit 0 is set, the CINT command is ignored. This allows multiple byte registers to be written as a 32-bit word. Reads of this register return all zeroes.

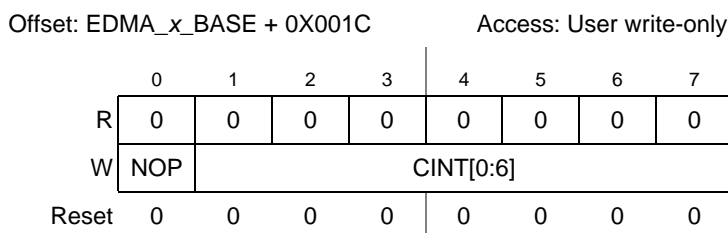

Figure 21-13. eDMA Clear Interrupt Request (EDMA_x_CIRQR)

Table 21-12. EDMA_x_CIRQR Field Descriptions

| Field | Description |
|-------------|--|
| 0 NOP | No operation. 0 Normal operation. 1 No operation, ignore bits 1-7. |
| 1-7 CINT | Clear Interrupt Request. 0-31 (63 for eDMA_A) Clear corresponding bit in EDMA_A_IRQRH or EDMA_x_IRQRL. 64-127 Clear all bits in EDMA_A_IRQRH or EDMA_x_IRQRL. Bit 2 (CIRQR[1]) is not used on eDMA_B. |

21.3.2.10 eDMA Clear Error Register (EDMA_x_CER)

The EDMA_x_CER provides a memory-mapped mechanism to clear a given bit in the EDMA_A_ERH or EDMA_x_ERL to disable the error condition flag for a given channel. The given value on a register write causes the corresponding bit in the EDMA_A_ERH or EDMA_x_ERL to be cleared. Setting bit 1 (CERR[0]) provides a global clear function, forcing the entire contents of the EDMA_A_ERH or EDMA_x_ERL to be zeroed, clearing all channel error indicators. Reads of this register return all zeroes.

If bit 0 is set, the CERR command is ignored. This allows multiple byte registers to be written as a 32-bit word. Reads of this register return all zeroes.

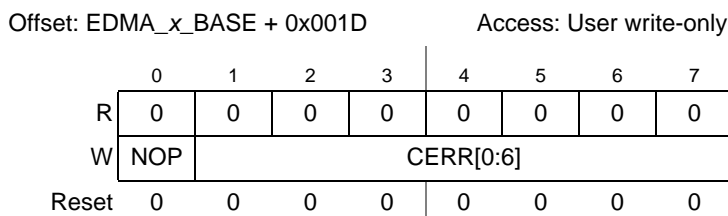

Figure 21-14. eDMA Clear Error Register (EDMA_x_CER)

Table 21-13. EDMA_x_CER Field Descriptions

| Field | Description |
|-------------|--|
| 0 NOP | No operation. 0 Normal operation. 1 No operation, ignore bits 1–7. |
| 1–7 CERR | Clear Error Indicator. 0–31 (63 for eDMA_A) Clear corresponding bit in EDMA_A_ERH or EDMA_x_ERL. 64–127 Clear all bits in EDMA_A_ERH or EDMA_x_ERL. Bit 2 (CER[1]) is not used on eDMA_B. |

21.3.2.11 eDMA Set START Bit Register (EDMA_x_SSBR)

The EDMA_x_SSBR provides a memory-mapped mechanism to set the START bit in the TCD of the given channel. The data value on a register write causes the START bit in the corresponding transfer control descriptor to be set. Setting bit 1 (SSB[0]) provides a global set function, forcing all START bits to be set. Reads of this register return all zeroes.

If bit 0 is set, the SSB command is ignored. This allows multiple byte registers to be written as a 32-bit word. Reads of this register return all zeroes.

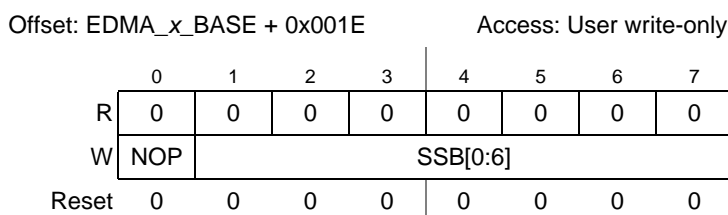

Figure 21-15. eDMA Set START Bit Register (EDMA_x_SSBR)

Table 21-14. EDMA_x_SSBR Field Descriptions

| Field | Description |
|------------|---|
| 0 NOP | No operation. 0 Normal operation. 1 No operation, ignore bits 1–7. |
| 1–7 SSB | Set START Bit (channel service request). 0–31 (63 for eDMA_A) Set the corresponding channel's TCD START bit. 64–127 Set all TCD START bits. Bit 2 (SSBR[1]) is not used on eDMA_B. |

21.3.2.12 eDMA Clear DONE Status Bit Register (EDMA_x_CDSBR)

The EDMA_x_CDSBR provides a memory-mapped mechanism to clear the DONE bit in the TCD of the given channel. The data value on a register write causes the DONE bit in the corresponding transfer control descriptor to be cleared. Setting bit 1 (CDSB[0]) provides a global clear function, forcing all DONE bits to be cleared.

If bit 0 is set, the CDSB command is ignored. This allows multiple byte registers to be written as a 32-bit word. Reads of this register return all zeroes.

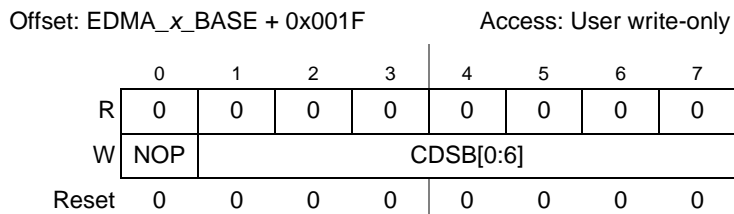
Figure 21-16. eDMA Clear DONE Status Bit Register (EDMA_x_CDSBR)
Table 21-15. EDMA_x_CDSBR Field Descriptions

| Field | Description |
|-------------|--|
| 0 NOP | No operation. 0 Normal operation. 1 No operation, ignore bits 1–7. |
| 1–7 CDSB | Clear DONE Status Bit. 0–31 (63 for eDMA_A) Clear the corresponding channel's DONE bit. 64–127 Clear all TCD DONE bits. Bit 2 (CDSBR[1]) is not used on eDMA_B. |

21.3.2.13 eDMA Interrupt Request Registers (EDMA_A_IRQRH, EDMA_x_IRQRL)

The EDMA_A_IRQRH and EDMA_x_IRQRL provide a bit map for the 32 channels signaling the presence of an interrupt request for each channel. EDMA_A_IRQRH maps to channels 63–32 and EDMA_x_IRQRL maps to channels 31–0.

The DMA engine signals the occurrence of a programmed interrupt on the completion of a data transfer as defined in the transfer control descriptor by setting the appropriate bit in this register. The outputs of this register are directly routed to the interrupt controller (INTC). During the execution of the interrupt service routine associated with any given channel, software must clear the appropriate bit, negating the interrupt request. Typically, a write to the EDMA_x_CIRQR in the interrupt service routine is used for this purpose.

The state of any given channel’s interrupt request is directly affected by writes to this register; it is also affected by writes to the EDMA_x_CIRQR. On writes to the EDMA_A_IRQRH or EDMA_x_IRQRL, a 1 in any bit position clears the corresponding channel’s interrupt request. A 0 in any bit position has no effect on the corresponding channel’s current interrupt status. The EDMA_x_CIRQR is provided so the interrupt request for a single channel can be cleared.

Address: EDMA_A_BASE + 0x0020

Access: User R/W

| | | | | | | | | | | | | | | | | |
|-------|-----|-----|-----|-----|-----|-----|-----|-----|-----|-----|-----|-----|-----|-----|-----|-----|
| | 0 | 1 | 2 | 3 | 4 | 5 | 6 | 7 | 8 | 9 | 10 | 11 | 12 | 13 | 14 | 15 |
| R | INT | INT | INT | INT | INT | INT | INT | INT | INT | INT | INT | INT | INT | INT | INT | INT |
| W | 63 | 62 | 61 | 60 | 59 | 58 | 57 | 56 | 55 | 54 | 53 | 52 | 51 | 50 | 49 | 48 |
| Reset | 0 | 0 | 0 | 0 | 0 | 0 | 0 | 0 | 0 | 0 | 0 | 0 | 0 | 0 | 0 | 0 |
| | 16 | 17 | 18 | 19 | 20 | 21 | 22 | 23 | 24 | 25 | 26 | 27 | 28 | 29 | 30 | 31 |
| R | INT | INT | INT | INT | INT | INT | INT | INT | INT | INT | INT | INT | INT | INT | INT | INT |
| W | 47 | 46 | 45 | 44 | 43 | 42 | 41 | 40 | 39 | 38 | 37 | 36 | 35 | 34 | 33 | 32 |
| Reset | 0 | 0 | 0 | 0 | 0 | 0 | 0 | 0 | 0 | 0 | 0 | 0 | 0 | 0 | 0 | 0 |

Figure 21-17. eDMA Interrupt Request High Register (EDMA_A_IRQRH)

Address: EDMA_x_BASE + 0x0024

Access: User read/write

| | | | | | | | | | | | | | | | | |
|-------|-----|-----|-----|-----|-----|-----|-----|-----|-----|-----|-----|-----|-----|-----|-----|-----|
| | 0 | 1 | 2 | 3 | 4 | 5 | 6 | 7 | 8 | 9 | 10 | 11 | 12 | 13 | 14 | 15 |
| R | INT | INT | INT | INT | INT | INT | INT | INT | INT | INT | INT | INT | INT | INT | INT | INT |
| W | 31 | 30 | 29 | 28 | 27 | 26 | 25 | 24 | 23 | 22 | 21 | 20 | 19 | 18 | 17 | 16 |
| Reset | 0 | 0 | 0 | 0 | 0 | 0 | 0 | 0 | 0 | 0 | 0 | 0 | 0 | 0 | 0 | 0 |
| | 16 | 17 | 19 | 19 | 20 | 21 | 22 | 23 | 24 | 25 | 26 | 27 | 28 | 29 | 30 | 31 |
| R | INT | INT | INT | INT | INT | INT | INT | INT | INT | INT | INT | INT | INT | INT | INT | INT |
| W | 15 | 14 | 13 | 12 | 11 | 10 | 09 | 08 | 07 | 06 | 05 | 04 | 03 | 02 | 01 | 00 |
| Reset | 0 | 0 | 0 | 0 | 0 | 0 | 0 | 0 | 0 | 0 | 0 | 0 | 0 | 0 | 0 | 0 |

Figure 21-18. eDMA Interrupt Request Register (EDMA_x_IRQRL)

Table 21-16. EDMA_x_IRQRL Field Descriptions

| Field | Description |
|-----------------|---|
| 0–31 INT n | eDMA Interrupt Request n . 0 The interrupt request for channel n is cleared. 1 The interrupt request for channel n is active. |

21.3.2.14 eDMA Error Registers (EDMA_x_ERH, EDMA_x_ERL)

The EDMA_A_ERH and EDMA_x_ERL provides a bit map for the 32 channels signaling the presence of an error for each channel. EDMA_A_ERH supports channels 63–32 (for eDMA_A) and EDMA_x_ERL maps to channels 31-0.

The DMA engine signals the occurrence of a error condition by setting the appropriate bit in this register. The outputs of this register are enabled by the contents of the EDMA_x_EEIR, then logically summed across across 32 (64 for eDMA_A) channels to form an error interrupt request, which is then routed to the interrupt controller. During the execution of the interrupt service routine associated with any eDMA errors, it is software’s responsibility to clear the appropriate bit, negating the error interrupt request. Typically, a write to the EDMA_x_CER in the interrupt service routine is used for this purpose. The normal eDMA channel completion indicators, setting the transfer control descriptor DONE flag and the possible assertion of an interrupt request, are not affected when an error is detected.

The contents of this register can also be polled and a non-zero value indicates the presence of a channel error, regardless of the state of the EDMA_x_EEIR. The EDMA_x_ESR[VLD] bit is a logical OR of all bits in this register and it provides a single bit indication of any errors. The state of any given channel’s error indicators is affected by writes to this register; it is also affected by writes to the EDMA_x_CER. On writes to EDMA_A_ERH or EDMA_x_ERL, a 1 in any bit position clears the corresponding channel’s error status. A 0 in any bit position has no effect on the corresponding channel’s current error status. The EDMA_x_CER is provided so the error indicator for a single channel can be cleared.

Address: EDMA_A_BASE + 0x0028

Access: User R/W

| | | | | | | | | | | | | | | | | |
|-------|-----|-----|-----|-----|-----|-----|-----|-----|-----|-----|-----|-----|-----|-----|-----|-----|
| | 0 | 1 | 2 | 3 | 4 | 5 | 6 | 7 | 8 | 9 | 10 | 11 | 12 | 13 | 14 | 15 |
| R | ERR | ERR | ERR | ERR | ERR | ERR | ERR | ERR | ERR | ERR | ERR | ERR | ERR | ERR | ERR | ERR |
| W | 63 | 62 | 61 | 60 | 59 | 58 | 57 | 56 | 55 | 54 | 53 | 52 | 51 | 50 | 49 | 48 |
| Reset | 0 | 0 | 0 | 0 | 0 | 0 | 0 | 0 | 0 | 0 | 0 | 0 | 0 | 0 | 0 | 0 |
| | 16 | 17 | 18 | 19 | 20 | 21 | 22 | 23 | 24 | 25 | 26 | 27 | 28 | 29 | 30 | 31 |
| R | ERR | ERR | ERR | ERR | ERR | ERR | ERR | ERR | ERR | ERR | ERR | ERR | ERR | ERR | ERR | ERR |
| W | 47 | 46 | 45 | 44 | 43 | 42 | 41 | 40 | 39 | 38 | 37 | 36 | 35 | 34 | 33 | 32 |
| Reset | 0 | 0 | 0 | 0 | 0 | 0 | 0 | 0 | 0 | 0 | 0 | 0 | 0 | 0 | 0 | 0 |

Figure 21-19. eDMA Error High Register (EDMA_A_ERH)

Address: EDMA_x_BASE + 0x002C

Access: User read/write

| | | | | | | | | | | | | | | | | |
|-------|-----|-----|-----|-----|-----|-----|-----|-----|-----|-----|-----|-----|-----|-----|-----|-----|
| | 0 | 1 | 2 | 3 | 4 | 5 | 6 | 7 | 8 | 9 | 10 | 11 | 12 | 13 | 14 | 15 |
| R | ERR | ERR | ERR | ERR | ERR | ERR | ERR | ERR | ERR | ERR | ERR | ERR | ERR | ERR | ERR | ERR |
| W | 31 | 30 | 29 | 28 | 27 | 26 | 25 | 24 | 23 | 22 | 21 | 20 | 19 | 18 | 17 | 16 |
| Reset | 0 | 0 | 0 | 0 | 0 | 0 | 0 | 0 | 0 | 0 | 0 | 0 | 0 | 0 | 0 | 0 |

| | | | | | | | | | | | | | | | | |
|-------|-----|-----|-----|-----|-----|-----|-----|-----|-----|-----|-----|-----|-----|-----|-----|-----|
| | 16 | 17 | 18 | 19 | 20 | 21 | 22 | 23 | 24 | 25 | 26 | 27 | 28 | 29 | 30 | 31 |
| R | ERR | ERR | ERR | ERR | ERR | ERR | ERR | ERR | ERR | ERR | ERR | ERR | ERR | ERR | ERR | ERR |
| W | 15 | 14 | 13 | 12 | 11 | 10 | 09 | 08 | 07 | 06 | 05 | 04 | 03 | 02 | 01 | 00 |
| Reset | 0 | 0 | 0 | 0 | 0 | 0 | 0 | 0 | 0 | 0 | 0 | 0 | 0 | 0 | 0 | 0 |

Figure 21-20. eDMA Error Register (EDMA_x_ERL)

Table 21-17. EDMA_x_ERL Field Descriptions

| Field | Description |
|-----------------|--|
| 0–31 ERR n | eDMA Error n . 0 An error in channel n has not occurred. 1 An error in channel n has occurred. |

21.3.2.15 DMA Hardware Request Status (EDMA_A_HRSH, EDMA_x_HRSL)

The EDMA_A_HRSL and EDMA_x_HRSL registers provide a bit map map for the implemented channels (32 or 64) to show the current hardware request status for each channel. EDMA_A_HRSH maps to channels 64–32 and EDMA_x_HRSL maps to channels 31-00.

Address: EDMA_A_BASE + 0x0030

Access: User R/W

| | | | | | | | | | | | | | | | | |
|-------|-----|-----|-----|-----|-----|-----|-----|-----|-----|-----|-----|-----|-----|-----|-----|-----|
| | 0 | 1 | 2 | 3 | 4 | 5 | 6 | 7 | 8 | 9 | 10 | 11 | 12 | 13 | 14 | 15 |
| R | HRS | HRS | HRS | HRS | HRS | HRS | HRS | HRS | HRS | HRS | HRS | HRS | HRS | HRS | HRS | HRS |
| W | 63 | 62 | 61 | 60 | 59 | 58 | 57 | 56 | 55 | 54 | 53 | 52 | 51 | 50 | 49 | 48 |
| Reset | 0 | 0 | 0 | 0 | 0 | 0 | 0 | 0 | 0 | 0 | 0 | 0 | 0 | 0 | 0 | 0 |

| | | | | | | | | | | | | | | | | |
|-------|-----|-----|-----|-----|-----|-----|-----|-----|-----|-----|-----|-----|-----|-----|-----|-----|
| | 16 | 17 | 18 | 19 | 20 | 21 | 22 | 23 | 24 | 25 | 26 | 27 | 28 | 29 | 30 | 31 |
| R | HRS | HRS | HRS | HRS | HRS | HRS | HRS | HRS | HRS | HRS | HRS | HRS | HRS | HRS | HRS | HRS |
| W | 47 | 46 | 45 | 44 | 43 | 42 | 41 | 40 | 39 | 38 | 37 | 36 | 35 | 34 | 33 | 32 |
| Reset | 0 | 0 | 0 | 0 | 0 | 0 | 0 | 0 | 0 | 0 | 0 | 0 | 0 | 0 | 0 | 0 |

Figure 21-21. EDMA Hardware Request Status Register High (EDMA_A_HRSH)

Address: EDMA_x_BASE + 0x0034

Access: User read/write

| | | | | | | | | | | | | | | | | |
|-------|-----|-----|-----|-----|-----|-----|-----|-----|-----|-----|-----|-----|-----|-----|-----|-----|
| | 0 | 1 | 2 | 3 | 4 | 5 | 6 | 7 | 8 | 9 | 10 | 11 | 12 | 13 | 14 | 15 |
| R | HRS | HRS | HRS | HRS | HRS | HRS | HRS | HRS | HRS | HRS | HRS | HRS | HRS | HRS | HRS | HRS |
| W | 31 | 30 | 29 | 28 | 27 | 26 | 25 | 24 | 23 | 22 | 21 | 20 | 19 | 18 | 17 | 16 |
| Reset | 0 | 0 | 0 | 0 | 0 | 0 | 0 | 0 | 0 | 0 | 0 | 0 | 0 | 0 | 0 | 0 |

| | | | | | | | | | | | | | | | | |
|-------|-----|-----|-----|-----|-----|-----|-----|-----|-----|-----|-----|-----|-----|-----|-----|-----|
| | 16 | 17 | 18 | 19 | 20 | 21 | 22 | 23 | 24 | 25 | 26 | 27 | 28 | 29 | 30 | 31 |
| R | HRS | HRS | HRS | HRS | HRS | HRS | HRS | HRS | HRS | HRS | HRS | HRS | HRS | HRS | HRS | HRS |
| W | 15 | 14 | 13 | 12 | 11 | 10 | 09 | 08 | 07 | 06 | 05 | 04 | 03 | 02 | 01 | 00 |
| Reset | 0 | 0 | 0 | 0 | 0 | 0 | 0 | 0 | 0 | 0 | 0 | 0 | 0 | 0 | 0 | 0 |

Figure 21-22. EDMA Hardware Request Status Register Low (EDMA_x_HRSL)
Table 21-18. EDMA_x_HRSL Field Descriptions

| Field | Description |
|--------------------------|--|
| 0–31 HRS _n | DMA Hardware Request Status 0 A hardware service request for channel <i>n</i> is not present. 1 A hardware service request for channel <i>n</i> is present. Note: The hardware request status reflects the state of the request as seen by the arbitration logic. Therefore, this status is affected by the EDMA_x_ERQRL[ERQ _n] bit. |

21.3.2.16 eDMA Global Write Registers (EDMA_x_GWRH and EDMA_x_GWRL)

The EDMA_x_GWRH and EDMA_x_GWRL registers provide coherency controls to the Cache Coherency Unit (CCU). The EDMA_x_GWRH and EDMA_x_GWRL registers provide a bit map to enable the CCU to snoop data writes from any enabled channel. When the Global Write Enable (GWEN) bit for a channel is set, the eDMA will signal the CCU whenever that channel performs a write. The EDMA_x_GWRH and EDMA_x_GWRL registers perform no functions within the eDMA.

21.3.2.17 eDMA Channel *n* Priority Registers (EDMA_x_CPR_n)

When the fixed-priority channel arbitration mode is enabled (EDMA_x_MCR[ERCA] = 0), the contents of these registers define the unique priorities associated with each channel. The channel priorities are evaluated by numeric value; that is, 0 is the lowest priority, 1 is the next higher priority, then 2, 3, etc. If software modifies channel priority values, then the software must ensure that the channel priorities contain unique values. Otherwise, a configuration error is reported. The range of the priority value is limited to the values of 0 through 15. When read, the GRPPRI bits of the EDMA_x_CPR_n register reflect the current priority level of the group of channels in which the corresponding channel resides. GRPPRI bits are not affected by writes to the EDMA_x_CPR_n registers. The group priority is assigned in the EDMA_x_MCR. See [Figure 21-2](#) and [Table 21-4](#) for the EDMA_x_MCR definition.

Channel preemption is enabled on a per-channel basis by setting the ECP bit in the EDMA_x_CPR_n register. Channel preemption allows the executing channel's data transfers to be temporarily suspended in favor of starting a higher priority channel. After the preempting channel has completed all its minor loop

data transfers, the preempted channel is restored and resumes execution. After the restored channel completes one read/write sequence, it is again eligible for preemption. If any higher priority channel requests service, the restored channel is suspended and the higher priority channel is serviced. Nested preemption (attempting to preempt a preempting channel) is not supported. After a preempting channel begins execution, it cannot be preempted. Preemption is available only when fixed arbitration is selected for both group and channel arbitration modes.

A channel's ability to pre-empt another channel can be disabled by setting EDMA_x_CPR[DPA]. When a channel's pre-empt ability is disabled, that channel cannot suspend a lower priority channel's data transfer; regardless of the lower priority channel's ECP setting. This allows for a pool of low priority, large data moving channels to be defined. These low priority channels can be configured to not preempt each other, thus preventing a low priority channel from consuming the preempt slot normally available a true, high priority channel.

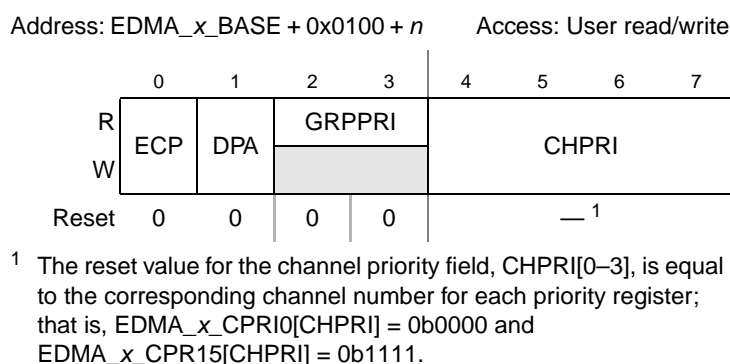

Figure 21-23. eDMA Channel n Priority Register (EDMA_x_CPRn)

Table 21-19. EDMA_x_CPRn Field Descriptions

| Field | Description |
|---------------|---|
| 0 ECP | Enable Channel Preemption. 0 Channel n cannot be suspended by a higher priority channel's service request. 1 Channel n can be temporarily suspended by the service request of a higher priority channel. |
| 1 DPA | Disable preempt ability. 0 Channel n can suspend a lower priority channel. 1 Channel n cannot suspend any channel, regardless of channel priority. |
| 2–3 GRPPRI | Channel n current group priority. Group priority assigned to this channel group when fixed-priority arbitration is enabled. These two bits are read-only; writes are ignored. The reset value for the group priority fields, is equal to the corresponding channel number for each priority register; that is, EDMA_x_CPR31[GRPPRI] = 0b01. |
| 4–7 CHPRI | Channel n Arbitration Priority. Channel priority when fixed-priority arbitration is enabled. The reset value for the channel priority fields CHPRI[0–3], is equal to the corresponding channel number for each priority register; that is, EDMA_x_CPR31[CHPRI] = 0b1111. |

21.3.2.18 Transfer Control Descriptor (TCD)

Each channel requires a 32-byte transfer control descriptor for defining the desired data movement operation. The channel descriptors are stored in the local memory in sequential order: channel 0, channel

1,... channel 31 (63 for eDMA_A). The definitions of the TCD are presented as eight 32-bit values. Table 21-20 is a field list of the basic TCD structure.

Table 21-20. TCD_n 32-bit Memory Structure

| eDMA Offset | TCD _n Field | |
|------------------------|--|--|
| 0x1000+(32 x n)+0x0000 | Source address (saddr) | |
| 0x1000+(32 x n)+0x0004 | Transfer attributes | Signed source address offset (soff) |
| 0x1000+(32 x n)+0x0008 | Inner minor byte count (nbytes) | |
| 0x1000+(32 x n)+0x000C | Last source address adjustment (slast) | |
| 0x1000+(32 x n)+0x0010 | Destination address (daddr) | |
| 0x1000+(32 x n)+0x0014 | Current major iteration count (citer) | Signed destination address offset (doff) |
| 0x1000 (32 x n) 0x0018 | Last destination address adjustment / scatter-gather address (dlast_sga) | |
| 0x1000+(32 x n)+0x001c | Beginning major iteration count (biter) | Channel control/status |

Figure 21-24 and Table 21-21 define the fields of the TCD_n structure.

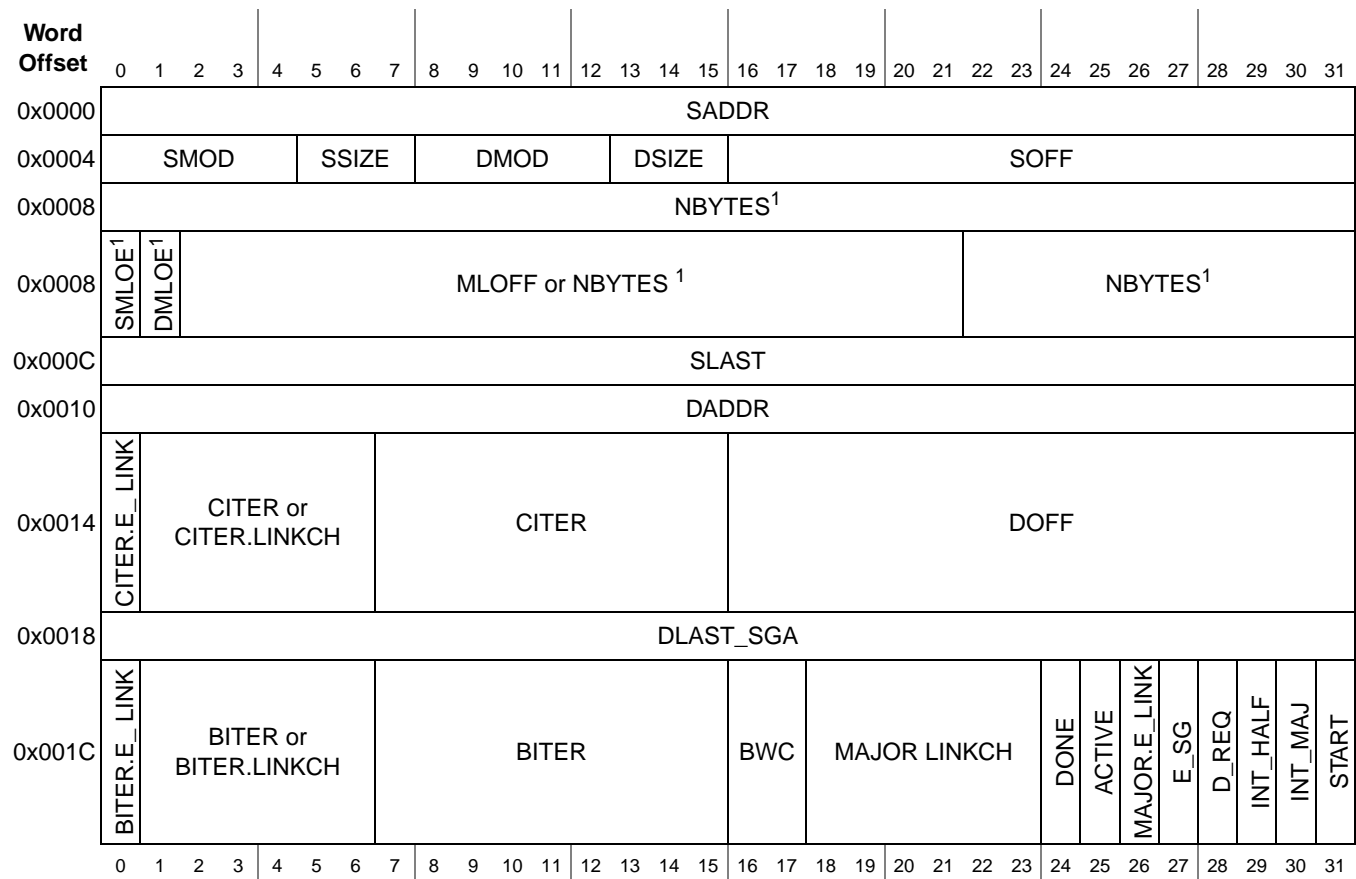

Figure 21-24. TCD Structure

¹ The fields implemented in Word 2 depend on whether EDMA_x_MCR(EMLM) is set to 0 or 1. Refer to Table 21-4.

NOTE

The TCD structures for the eDMA channels shown in [Figure 21-24](#) are implemented in internal SRAM. These structures are not initialized at reset; therefore, all channel TCD parameters must be initialized by the application code before activating that channel.

Table 21-21. TCDn Field Descriptions

| Field | Description |
|-------------------------------------|---|
| 0–31 / 0x0 [0:31] SADDR | Source address. Memory address pointing to the source data. Word 0x0, bits 0–31. |
| 32–36 / 0x4 [0:4] SMOD | Source address modulo. 0 Source address modulo feature is disabled. non-0 This value defines a specific address range that is specified to be the value after SADDR + SOFF calculation is performed or the original register value. The setting of this field provides the ability to easily implement a circular data queue. For data queues requiring power-of-2 size bytes, the queue should start at a 0-modulo-size address and the SMOD field should be set to the appropriate value for the queue, freezing the desired number of upper address bits. The value programmed into this field specifies the number of lower address bits that are allowed to change. For this circular queue application, the SOFF is typically set to the transfer size to implement post-increment addressing with the SMOD function constraining the addresses to a 0-modulo-size range. |
| 37–39 / 0x4 [5:7] SSIZE | Source data transfer size. 000 8-bit 001 16-bit 010 32-bit 011 64-bit 100 Reserved 101 32-byte (64-bit, 4 beat, WRAP4 burst) 110 Reserved 111 Reserved The attempted specification of a reserved encoding causes a configuration error. |
| 40–44 / 0x4 [8:12] DMOD | Destination address modulo. See the SMOD[0:5] definition. |
| 45–47 / 0x4 [13:15] DSIZE | Destination data transfer size. See the SSIZE[0:2] definition. |
| 48–63 / 0x4 [16:31] SOFF | Source address signed offset. Sign-extended offset applied to the current source address to form the next-state value as each source read is completed. |
| 64 0x8 [0] SMLOE ¹ | Source minor loop offset enable This flag selects whether the minor loop offset is applied to the source address upon minor loop completion. 0 The minor loop offset is not applied to the saddr. 1 The minor loop offset is applied to the saddr. |

Table 21-21. TCDn Field Descriptions (continued)

| Field | Description |
|--|--|
| 65 0x8 [1] DMLOE ¹ | Destination minor loop offset enable This flag selects whether the minor loop offset is applied to the destination address upon minor loop completion. 0 The minor loop offset is not applied to the daddr. 1 The minor loop offset is applied to the daddr. |
| 66–85 0x8 [2-21] MLOFF or NBYTES ¹ | Inner “minor” byte transfer count or Minor loop offset If both SMLOE and DMLOE are cleared, this field is part of the byte transfer count. If either SMLOE or DMLOE are set, this field represents a sign-extended offset applied to the source or destination address to form the next-state value after the minor loop is completed. |
| 86–95 / 0x8 [22:31] NBYTES ¹ | Inner “minor” byte transfer count. Number of bytes to be transferred in each service request of the channel. As a channel is activated, the contents of the appropriate TCD is loaded into the eDMA engine, and the appropriate reads and writes performed until the complete byte transfer count has been transferred. This is an indivisible operation and cannot be stalled or halted. Once the minor count is exhausted, the current values of the SADDR and DADDR are written back into the local memory, the major iteration count is decremented and restored to the local memory. If the major iteration count is completed, additional processing is performed. Note: The NBYTES value of 0x0000_0000 is interpreted as 0x1_0000_0000, thus specifying a 4 GB transfer. |
| 96–127 / 0xC [0:31] SLAST | Last source address adjustment. Adjustment value added to the source address at the completion of the outer major iteration count. This value can be applied to “restore” the source address to the initial value, or adjust the address to reference the next data structure. |
| 128–159 / 0x10 [0:31] DADDR | Destination address. Memory address pointing to the destination data. |
| 160 / 0x14 [0] CITER.E_LINK | Enable channel-to-channel linking on minor loop completion. As the channel completes the inner minor loop, this flag enables the linking to another channel, defined by CITER.LINKCH[0:5]. The link target channel initiates a channel service request via an internal mechanism that sets the EDMA_x_TCD.START bit of the specified channel. If channel linking is disabled, the CITER value is extended to 15 bits in place of a link channel number. If the major loop is exhausted, this link mechanism is suppressed in favor of the MAJOR.E_LINK channel linking. 0 The channel-to-channel linking is disabled. 1 The channel-to-channel linking is enabled. Note: This bit must be equal to the BITER.E_LINK bit. Otherwise, a configuration error is reported. |
| 161–166 / 0x14 [1:6] CITER or CITER.LINKCH | Current major iteration count or link channel number. If channel-to-channel linking is disabled (EDMA_x_TCD.CITER.E_LINK = 0), then <ul style="list-style-type: none"> No channel-to-channel linking (or chaining) is performed after the inner minor loop is exhausted. TCD bits [161:175] are used to form a 15-bit CITER field. Otherwise, <ul style="list-style-type: none"> After the minor loop is exhausted, the DMA engine initiates a channel service request at the channel defined by CITER.LINKCH[0:5] by setting that channel's EDMA_x_TCD.START bit. |

Table 21-21. TCDn Field Descriptions (continued)

| Field | Description |
|--|--|
| 167–175 / 0x14 [7:15] CITER | <p>Current major iteration count. This 9 or 15-bit count represents the current major loop count for the channel. It is decremented each time the minor loop is completed and updated in the transfer control descriptor memory. After the major iteration count is exhausted, the channel performs a number of operations (for example, final source and destination address calculations), optionally generating an interrupt to signal channel completion before reloading the CITER field from the beginning iteration count (BITER) field.</p> <p>Note: When the CITER field is initially loaded by software, it must be set to the same value as that contained in the BITER field.</p> <p>Note: If the channel is configured to execute a single service request, the initial values of BITER and CITER should be 0x0001.</p> |
| 176–191 / 0x14 [16:31] DOFF | <p>Destination address signed Offset. Sign-extended offset applied to the current destination address to form the next-state value as each destination write is completed.</p> |
| 192–223 / 0x18 [0:31] DLAST_SGA | <p>Last destination address adjustment or the memory address for the next transfer control descriptor to be loaded into this channel (scatter-gather).</p> <p>If scatter-gather processing for the channel is disabled (EDMA_x_TCD.E_SG = 0) then</p> <ul style="list-style-type: none"> Adjustment value added to the destination address at the completion of the outer major iteration count. <p>This value can be applied to restore the destination address to the initial value, or adjust the address to reference the next data structure.</p> <p>Otherwise,</p> <ul style="list-style-type: none"> This address points to the beginning of a 0-modulo-32 byte region containing the next transfer control descriptor to be loaded into this channel. This channel reload is performed as the major iteration count completes. The scatter-gather address must be 0-modulo-32 byte, otherwise a configuration error is reported. |
| 224 / 0x1C [0] BITER.E_LINK | <p>Enables channel-to-channel linking on minor loop complete. As the channel completes the inner minor loop, this flag enables the linking to another channel, defined by BITER.LINKCH[0:5]. The link target channel initiates a channel service request via an internal mechanism that sets the EDMA_x_TCD.START bit of the specified channel. If channel linking is disabled, the BITER value is extended to 15 bits in place of a link channel number. If the major loop is exhausted, this link mechanism is suppressed in favor of the MAJOR.E_LINK channel linking.</p> <p>0 The channel-to-channel linking is disabled. 1 The channel-to-channel linking is enabled.</p> <p>Note: When the TCD is first loaded by software, this field must be set equal to the corresponding CITER field. Otherwise, a configuration error is reported. As the major iteration count is exhausted, the contents of this field is reloaded into the CITER field.</p> |
| 225–230 / 0x1C [1:6] BITER or BITER.LINKCH | <p>Starting major iteration count or link channel number.</p> <p>If channel-to-channel linking is disabled (EDMA_x_TCD.BITER.E_LINK = 0), then</p> <ul style="list-style-type: none"> No channel-to-channel linking (or chaining) is performed after the inner minor loop is exhausted. TCD bits [225:239] are used to form a 15-bit BITER field. <p>Otherwise,</p> <ul style="list-style-type: none"> After the minor loop is exhausted, the DMA engine initiates a channel service request at the channel, defined by BITER.LINKCH[0:5], by setting that channel's EDMA_x_TCD.START bit. <p>Note: When the TCD is first loaded by software, this field must be set equal to the corresponding CITER field. Otherwise, a configuration error is reported. As the major iteration count is exhausted, the contents of this field is reloaded into the CITER field.</p> |

Table 21-21. TCDn Field Descriptions (continued)

| Field | Description |
|---|---|
| 231–239 / 0x1C [7:15] BITER | Starting major iteration count. As the transfer control descriptor is first loaded by software, this field must be equal to the value in the CITER field. As the major iteration count is exhausted, the contents of this field are reloaded into the CITER field. Note: If the channel is configured to execute a single service request, the initial values of BITER and CITER should be 0x0001. |
| 240–241 / 0x1C [16:17] BWC | Bandwidth control. This two-bit field provides a mechanism to effectively throttle the amount of bus bandwidth consumed by the eDMA. In general, as the eDMA processes the inner minor loop, it continuously generates read/write sequences until the minor count is exhausted. This field forces the eDMA to stall after the completion of each read/write access to control the bus request bandwidth seen by the system bus crossbar switch (XBAR). 00 No DMA engine stalls 01 Reserved 10 DMA engine stalls for 4 cycles after each r/w 11 DMA engine stalls for 8 cycles after each r/w |
| 242–247 / 0x1C [18:23] MAJOR.LINKCH | Link channel number. If channel-to-channel linking on major loop complete is disabled (EDMA_x_TCD.MAJOR.E_LINK = 0) then, <ul style="list-style-type: none"> No channel-to-channel linking (or chaining) is performed after the outer major loop counter is exhausted. Otherwise <ul style="list-style-type: none"> After the major loop counter is exhausted, the DMA engine initiates a channel service request at the channel defined by MAJOR.LINKCH[0:5] by setting that channel's EDMA_x_TCD.START bit. |
| 248 / 0x1C [24] DONE | Channel done. This flag indicates the eDMA has completed the outer major loop. It is set by the DMA engine as the CITER count reaches zero; it is cleared by software or hardware when the channel is activated (when the DMA engine has begun processing the channel, not when the first data transfer occurs). Note: This bit must be cleared to write the MAJOR.E_LINK or E_SG bits. |
| 249 / 0x1C [25] ACTIVE | Channel active. This flag signals the channel is currently in execution. It is set when channel service begins, and is cleared by the DMA engine as the inner minor loop completes or if any error condition is detected. |
| 250 / 0x1C [26] MAJOR.E_LINK | Enable channel-to-channel linking on major loop completion. As the channel completes the outer major loop, this flag enables the linking to another channel, defined by MAJOR.LINKCH[0:5]. The link target channel initiates a channel service request via an internal mechanism that sets the EDMA_x_TCD.START bit of the specified channel. Note: To support the dynamic linking coherency model, this field is forced to zero when written to while the EDMA_x_TCD.DONE bit is set. 0 The channel-to-channel linking is disabled. 1 The channel-to-channel linking is enabled. |
| 251 / 0x1C [27] E_SG | Enable scatter-gather processing. As the channel completes the outer major loop, this flag enables scatter-gather processing in the current channel. If enabled, the DMA engine uses DLAST_SGA as a memory pointer to a 0-modulo-32 address containing a 32-byte data structure which is loaded as the transfer control descriptor into the local memory. Note: To support the dynamic scatter-gather coherency model, this field is forced to zero when written to while the EDMA_x_TCD.DONE bit is set. 0 The current channel's TCD is normal format. 1 The current channel's TCD specifies a scatter gather format. The DLAST_SGA field provides a memory pointer to the next TCD to be loaded into this channel after the outer major loop completes its execution. |

Table 21-21. TCDn Field Descriptions (continued)

| Field | Description |
|--------------------------------|---|
| 252 / 0x1C [28] D_REQ | Disable hardware request. If this flag is set, the eDMA hardware automatically clears the corresponding EDMA_A_ERQH or EDMA_x_ERQL bit when the current major iteration count reaches zero. 0 The channel's EDMA_A_ERQH or EDMA_x_ERQL bit is not affected. 1 The channel's EDMA_A_ERQH or EDMA_x_ERQL bit is cleared when the outer major loop is complete. |
| 253 / 0x1C [29] INT_HALF | Enable an interrupt when major counter is half complete. If this flag is set, the channel generates an interrupt request by setting the appropriate bit in the EDMA_A_ERQH or EDMA_x_ERQL when the current major iteration count reaches the halfway point. Specifically, the comparison performed by the eDMA engine is $(CITER == (BITER \gg 1))$. This halfway point interrupt request is provided to support double-buffered (aka ping-pong) schemes, or other types of data movement where the processor needs an early indication of the transfer's progress. $CITER = BITER = 1$ with INT_HALF enabled will generate an interrupt as it satisfies the equation $(CITER == (BITER \gg 1))$ after a single activation. 0 The half-point interrupt is disabled. 1 The half-point interrupt is enabled. |
| 254 / 0x1C [30] INT_MAJ | Enable an interrupt when major iteration count completes. If this flag is set, the channel generates an interrupt request by setting the appropriate bit in the EDMA_A_ERQH or EDMA_x_ERQL when the current major iteration count reaches zero. 0 The end-of-major loop interrupt is disabled. 1 The end-of-major loop interrupt is enabled. |
| 255 / 0x1C [31] START | Channel start. If this flag is set the channel is requesting service. The eDMA hardware automatically clears this flag after the channel begins execution. 0 The channel is not explicitly started. 1 The channel is explicitly started via a software initiated service request. |

21.4 Functional Description

This section provides an overview of the microarchitecture and functional operation of the eDMA block.

The eDMA module is partitioned into two major modules: the DMA engine and the transfer control descriptor local memory. The DMA engine is further partitioned into four submodules, which are detailed below.

- DMA engine
 - Address path: This module implements registered versions of two channel transfer control descriptors: channel x and channel y, and is responsible for all the master bus address calculations. All the implemented channels provide the same functionality. This hardware structure allows the data transfers associated with one channel to be preempted after the completion of a read/write sequence if a higher priority channel service request is asserted while the first channel is active. After a channel is activated, it runs until the minor loop is completed unless preempted by a higher priority channel. This capability provides a mechanism (optionally enabled by EDMA_x_CPRn[ECP]) where a large data move operation can be preempted to minimize the time another channel is blocked from execution.
 - When another channel is activated, the contents of its transfer control descriptor is read from the local memory and loaded into the registers of the other address path channel{x,y}. After the inner minor loop completes execution, the address path hardware writes the new values for

the TCD n .{SADDR, DADDR, CITER} back into the local memory. If the major iteration count is exhausted, additional processing is performed, including the final address pointer updates, reloading the TCD n .CITER field, and a possible fetch of the next TCD n from memory as part of a scatter-gather operation.

- Data path: This module implements the actual bus master read/write datapath. It includes 32 bytes of register storage (matching the maximum transfer size) and the necessary mux logic to support any required data alignment. The system read data bus is the primary input, and the system write data bus is the primary output.
- The address and data path modules directly support the two-stage pipelined system bus. The address path module represents the 1st stage of the bus pipeline (the address phase), while the data path module implements the second stage of the pipeline (the data phase).
- Program model/channel arbitration: This module implements the first section of eDMA's programming model and also the channel arbitration logic. The programming model registers are connected to the slave bus (not shown). The eDMA peripheral request inputs and eDMA interrupt request outputs are also connected to this module (via the control logic).
- Control: This module provides all the control functions for the DMA engine. For data transfers where the source and destination sizes are equal, the DMA engine performs a series of source read, destination write operations until the number of bytes specified in the inner minor loop byte count has been moved.

A minor loop interaction is defined as the number of bytes to transfer (n bytes) divided by the transfer size. Transfer size is defined as:

if (SSIZE < DSIZE)

transfer size = destination transfer size (# of bytes)

else

transfer size = source transfer size (# of bytes)

Minor loop TCD variables are SOFF, SMOD, DOFF, DMOD, NBYTES, SADDR, DADDR, BWC, ACTIVE, AND START. Major loop TCD variables are DLAST, SLAST, CITER, BITER, DONE, D_REQ, INT_MAJ, MAJOR_LNKCH, and INT_HALF.

For descriptors where the sizes are not equal, multiple access of the smaller size data are required for each reference of the larger size. For example, if the source size references 16-bit data and the destination is 32-bit data, two reads are performed, then one 32-bit write.

- TCD local memory
 - Memory controller: This logic implements the required dual-ported controller, handling accesses from both the DMA engine as well as references from the slave bus. As noted earlier, in the event of simultaneous accesses, the DMA engine is given priority and the slave transaction is stalled.
 - Memory array: The TCD is implemented using a single-ported, synchronous compiled RAM memory array.

21.4.1 eDMA Basic Data Flow

The eDMA transfers data based on a two-deep, nested flow. The basic flow of a data transfer can be partitioned into three segments. As shown in Figure 21-25, the first segment involves the channel service request. In the diagram, this example uses the assertion of the eDMA peripheral request signal to request service for channel n . Channel service request via software and the TCDn.START bit follows the same basic flow as an eDMA peripheral request. The eDMA peripheral request input signal is registered internally and then routed through the DMA engine, first through the control module, then into the program model/channel arbitration module. In the next cycle, the channel arbitration is performed using the fixed-priority or round-robin algorithm. After the arbitration is complete, the activated channel number is sent through the address path and converted into the required address to access the TCD local memory. Next, the TCD memory is accessed and the required descriptor read from the local memory and loaded into the DMA engine address path channel {x,y} registers. The TCD memory is organized 64-bits in width to minimize the time needed to fetch the activated channel's descriptor and load it into the eDMA engine address path channel {x,y} registers.

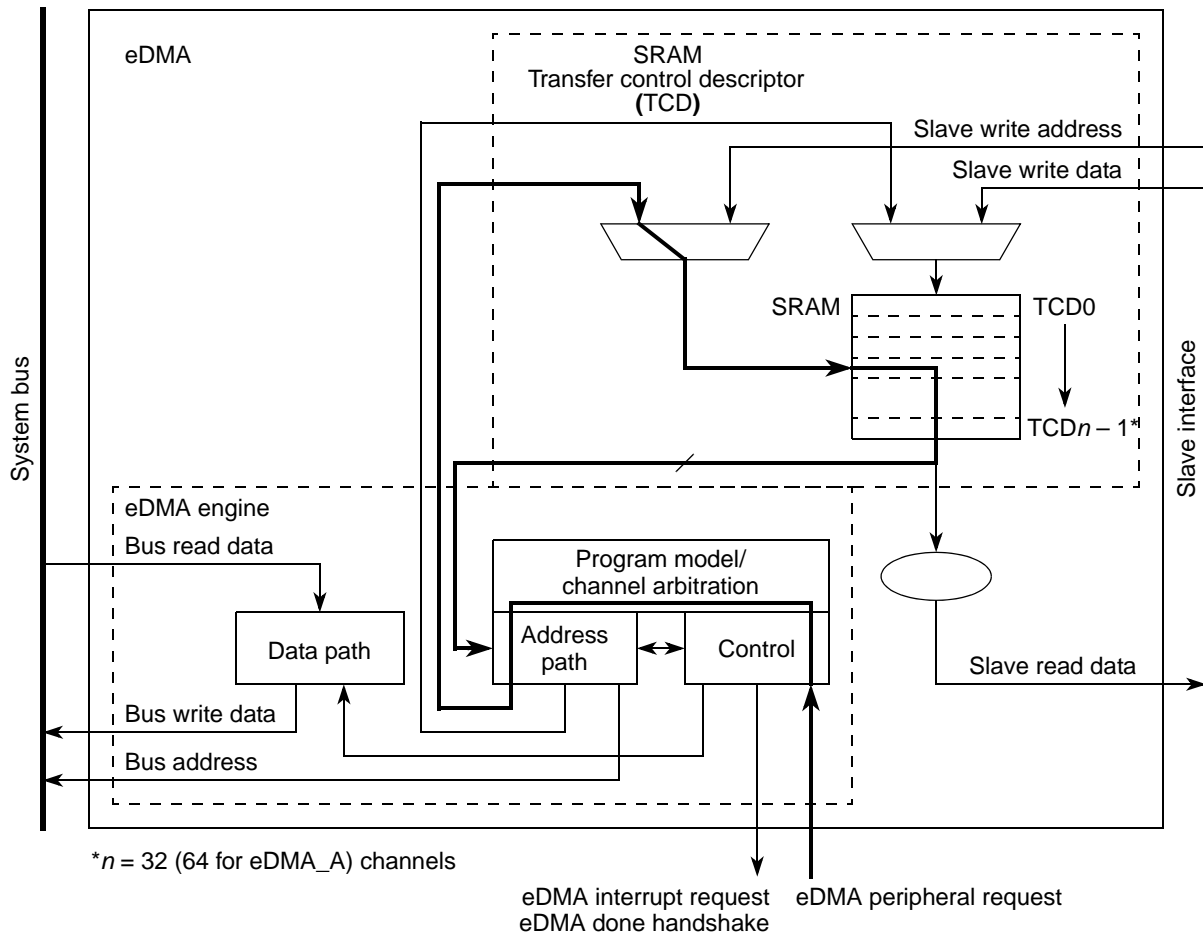

Figure 21-25. eDMA Operation, Part 1

In the second part of the basic data flow as shown in Figure 21-26, the modules associated with the data transfer (address path, data path, and control) sequence through the required source reads and destination writes to perform the actual data movement. The source reads are initiated and the fetched data is

temporarily stored in the data path module until it is gated onto the system bus during the destination write. This source read/destination write processing continues until the inner minor byte count has been transferred. The eDMA done handshake signal is asserted at the end of the minor byte count transfer.

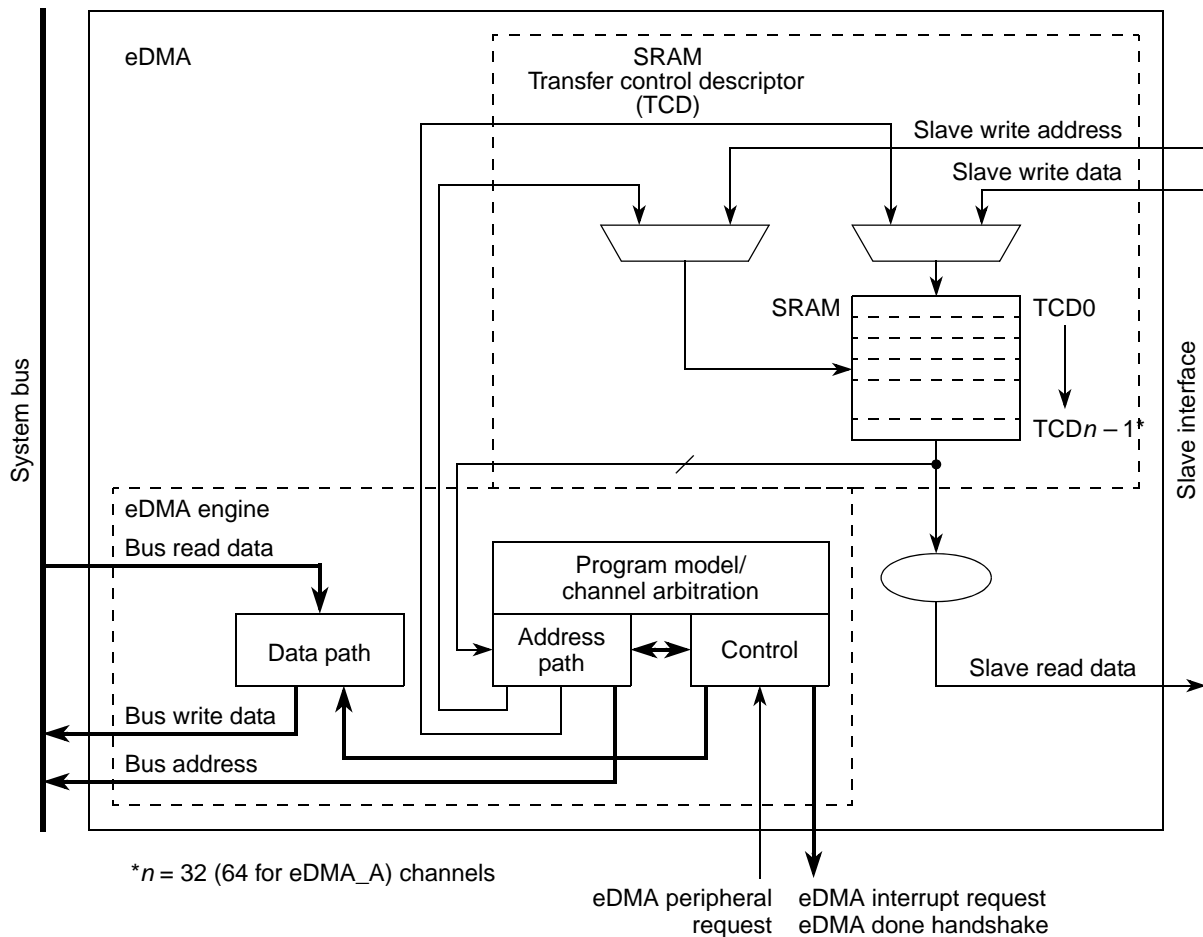

Figure 21-26. eDMA Operation, Part 2

After the inner minor byte count has been moved, the final phase of the basic data flow is performed. In this segment, the address path logic performs the required updates to certain fields in the channel's TCD; for example, SADDR, DADDR, CITER. If the outer major iteration count is exhausted, then there are additional operations performed. These include the final address adjustments and reloading of the BITER field into the CITER. Additionally, assertion of an optional interrupt request occurs at this time, as does a possible fetch of a new TCD from memory using the scatter-gather address pointer included in the descriptor. The updates to the TCD memory and the assertion of an interrupt request are shown in [Figure 21-27](#).

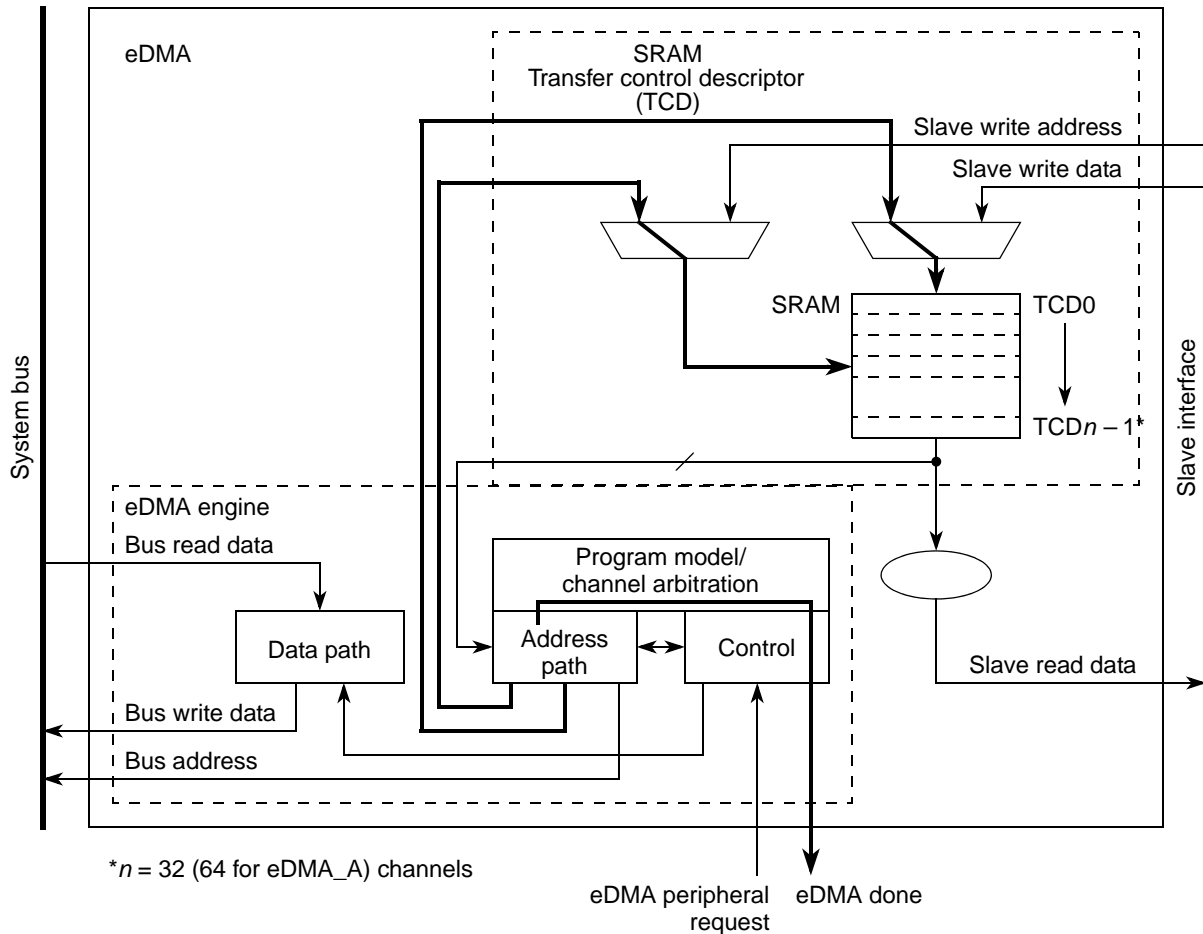

Figure 21-27. eDMA Operation, Part 3

21.5 Initialization / Application Information

21.5.1 eDMA Initialization

A typical initialization of the eDMA has the following sequence:

1. Write the EDMA_x_MCR if a configuration other than the default is desired.
2. Write the channel priority levels into the EDMA_x_CPR_n registers if a configuration other than the default is desired.
3. Enable error interrupts in the EDMA_x_EEIRL and/or EDMA_x_EEIRH registers if desired.
4. Write the 32-byte TCD for each channel that may request service.
5. Enable any hardware service requests via the EDMA_x_ERQRH and/or EDMA_x_ERQRL registers.
6. Request channel service by software (setting the EDMA_x_TCD.START bit) or by hardware (slave device asserting its DMA peripheral request signal).

After any channel requests service, a channel is selected for execution based on the arbitration and priority levels written into the programmer's model. The DMA engine reads the entire TCD, including the primary transfer control parameter shown in [Table 21-22](#), for the selected channel into its internal address path module. As the TCD is being read, the first transfer is initiated on the system bus unless a configuration error is detected. Transfers from the source (as defined by the source address, EDMA_x_TCD.SADDR) to the destination (as defined by the destination address, EDMA_x_TCD.DADDR) continue until the specified number of bytes (EDMA_x_TCD.NBYTES) have been transferred. When the transfer is complete, the DMA engine's local EDMA_x_TCD.SADDR, EDMA_x_TCD.DADDR, and EDMA_x_TCD.CITER are written back to the main TCD memory and any minor loop channel linking is performed, if enabled. If the major loop is exhausted, further post processing is executed; for example, interrupts, major loop channel linking, and scatter-gather operations, if enabled.

Table 21-22. TCD Primary Control and Status Fields

| TCD Field Name | Description |
|----------------|--|
| START | Control bit to start channel when using a software initiated DMA service (Automatically cleared by hardware) |
| ACTIVE | Status bit indicating the channel is currently in execution |
| DONE | Status bit indicating major loop completion (cleared by software when using a software initiated DMA service) |
| D_REQ | Control bit to disable DMA request at end of major loop completion when using a hardware-initiated DMA service |
| BWC | Control bits for throttling bandwidth control of a channel |
| E_SG | Control bit to enable scatter-gather feature |
| INT_HALF | Control bit to enable interrupt when major loop is half complete |
| INT_MAJ | Control bit to enable interrupt when major loop completes |

[Figure 21-28](#) shows how each DMA request initiates one minor loop transfer (iteration) without CPU intervention. DMA arbitration can occur after each minor loop, and one level of minor loop DMA preemption is allowed. The number of minor loops in a major loop is specified by the beginning iteration count (biter).

| Example memory array | | | Current major loop iteration count (CITER) | | |
|----------------------|---|------------|--|------------|------------|
| DMA request | | Minor loop | Major loop | 3 | |
| | | | | | |
| | ⋮ | | | | |
| | | | | | |
| DMA request | | Minor loop | | Major loop | 2 |
| | | | | | |
| | ⋮ | | | | |
| | | | | | |
| DMA request | | Minor loop | | | Major loop |
| | | | | | |
| | ⋮ | | | | |
| | | | | | |

Figure 21-28. Example of Multiple Loop Iterations

Figure 21-29 lists the memory array terms and how the TCD settings interrelate.

| | | | |
|--|---------------------------------------|---|--|
| xADDR: (Starting address) | xSIZE: (Size of one data transfer) | Minor loop (NBYTES in minor loop, often the same value as xSIZE) | Offset (xOFF): Number of bytes added to current address after each transfer (Often the same value as xSIZE) Each DMA source (S) and destination (D) has its own: <ul style="list-style-type: none"> • Address (xADDR) • Size (xSIZE) • Offset (xOFF) • Modulo (xMOD) • Last address adjustment (xLAST) where x = S or D Peripheral queues typically have size and offset equal to NBYTES |
| ⋮ | ⋮ | Minor loop | |
| xLAST: Number of bytes added to current address after major loop (typically used to loop back) | ⋮ | Last minor loop | |

Figure 21-29. Memory Array Terms

21.5.2 DMA Programming Errors

The DMA performs various tests on the transfer control descriptor to verify consistency in the descriptor data. Most programming errors are reported on a per-channel basis with the exception of two errors: group-priority error and channel-priority error, or EDMA_x_ESR[GPE] and EDMA_x_ESR[CPE], respectively.

For all error types other than group- or channel-priority errors, the channel number causing the error is recorded in the EDMA_x_ESR. If the error source is not removed before the next activation of the problem channel, the error is detected and recorded again.

Channel-priority errors are identified within a group after that group has been selected as the active group. For the example, all of the channel priorities in group 1 are unique, but some of the channel priorities in group 0 are the same:

1. The DMA is configured for fixed-group and fixed-channel arbitration modes.
2. Group 1 is the highest priority and all channels are unique in that group.
3. Group 0 is the next highest priority and has two channels with the same priority level.
4. If group 1 has any service requests, those requests are executed.
5. After all of group 1 requests have completed, group 0 becomes the next active group.
6. If group 0 has a service request, then an undefined channel in group 0 is selected and a channel-priority error will occur.
7. This repeats until the all of group 0 requests have been removed or a higher priority group 1 request comes in.

In this sequence, for item 2, the DMA acknowledge lines assert only if the selected channel is requesting service via the DMA peripheral request signal. If interrupts are enabled for all channels, the user receives an error interrupt, but the channel number for the EDMA_x_ER and the error interrupt request line are undetermined because they reflect the undefined channel. A group-priority error is global and any request in any group causes a group-priority error.

If priority levels are not unique, the highest (channel/group) priority that has an active request is selected, but the lowest numbered (channel/group) with that priority is selected by arbitration and executed by the DMA engine. The hardware service request handshake signals, error interrupts, and error reporting are associated with the selected channel.

21.5.3 DMA Request Assignments

The assignments between the DMA requests from the modules to the channels of the two eDMAs are shown in [Table 21-24](#) and [Table 21-24](#). The source column is written in C language syntax. The syntax is `module_instance.register[bit]`.

Table 21-23. DMA Request Summary for eDMA_A

| DMA Request | Channel | Source | Description |
|---------------------|---------|---|---|
| EQADC_A_FISR0_CFFF0 | 0 | EQADC_A.FISR0[CFFF0] | EQADC_A Command FIFO 0 Fill Flag |
| EQADC_A_FISR0_RFDF0 | 1 | EQADC_A.FISR0[RFDF0] | EQADC_A Receive FIFO 0 Drain Flag |
| EQADC_A_FISR1_CFFF1 | 2 | EQADC_A.FISR1[CFFF1] | EQADC_A Command FIFO 1 Fill Flag |
| EQADC_A_FISR1_RFDF1 | 3 | EQADC_A.FISR1[RFDF1] | EQADC_A Receive FIFO 1 Drain Flag |
| EQADC_A_FISR2_CFFF2 | 4 | EQADC_A.FISR2[CFFF2] | EQADC_A Command FIFO 2 Fill Flag |
| EQADC_A_FISR2_RFDF2 | 5 | EQADC_A.FISR2[RFDF2] | EQADC_A Receive FIFO 2 Drain Flag |
| EQADC_A_FISR3_CFFF3 | 6 | EQADC_A.FISR3[CFFF3] | EQADC_A Command FIFO 3 Fill Flag |
| EQADC_A_FISR3_RFDF3 | 7 | EQADC_A.FISR3[RFDF3] | EQADC_A Receive FIFO 3 Drain Flag |
| EQADC_A_FISR4_CFFF4 | 8 | EQADC_A.FISR4[CFFF4] | EQADC_A Command FIFO 4 Fill Flag |
| EQADC_A_FISR4_RFDF4 | 9 | EQADC_A.FISR4[RFDF4] | EQADC_A Receive FIFO 4 Drain Flag |
| EQADC_A_FISR5_CFFF5 | 10 | EQADC_A.FISR5[CFFF5] | EQADC_A Command FIFO 5 Fill Flag |
| EQADC_A_FISR5_RFDF5 | 11 | EQADC_A.FISR5[RFDF5] | EQADC_A Receive FIFO 5 Drain Flag |
| DSPIB_SR_TFFF | 12 | DSPIB.SR[TFFF] | DSPIB Transmit FIFO Fill Flag |
| DSPIB_SR_RFDF | 13 | DSPIB.SR[RFDF] | DSPIB Receive FIFO Drain Flag |
| DSPIC_SR_TFFF | 14 | DSPIC.SR[TFFF] | DSPIC Transmit FIFO Fill Flag |
| DSPIC_SR_RFDF | 15 | DSPIC.SR[RFDF] | DSPIC Receive FIFO Drain Flag |
| DSPID_SR_TFFF | 16 | DSPID.SR[TFFF] | DSPID Transmit FIFO Fill Flag |
| DSPID_SR_RFDF | 17 | DSPID.SR[RFDF] | DSPID Receive FIFO Drain Flag |
| eSCIA_COMBTX | 18 | ESCIA.SR[TDRE] ESCIA.SR[TC] ESCIA.SR[TXRDY] | eSCIA combined DMA request of the Transmit Data Register Empty, Transmit Complete, and LIN Transmit Data Ready DMA requests |
| eSCIA_COMBRX | 19 | ESCIA.SR[RDRF] ESCIA.SR[RXRDY] | eSCIA combined DMA request of the Receive Data Register Full and LIN Receive Data Ready DMA requests |
| eMIOS_GFR_F0 | 20 | EMIOS.GFR[F0] | eMIOS channel 0 Flag |
| eMIOS_GFR_F1 | 21 | EMIOS.GFR[F1] | eMIOS channel 1 Flag |
| eMIOS_GFR_F2 | 22 | EMIOS.GFR[F2] | eMIOS channel 2 Flag |
| eMIOS_GFR_F3 | 23 | EMIOS.GFR[F3] | eMIOS channel 3 Flag |
| eMIOS_GFR_F4 | 24 | EMIOS.GFR[F4] | eMIOS channel 4 Flag |

Table 21-23. DMA Request Summary for eDMA_A (continued)

| DMA Request | Channel | Source | Description |
|----------------------|---------|---|---|
| eMIOS_GFR_F8 | 25 | EMIOS.GFR[F8] | eMIOS channel 8 Flag |
| eMIOS_GFR_F9 | 26 | EMIOS.GFR[F9] | eMIOS channel 9 Flag |
| eTPU_CDTRSR_A_DTRS0 | 27 | ETPU.CDTRSR_A[DTRS0] | eTPUA Channel 0 Data Transfer Request Status |
| eTPU_CDTRSR_A_DTRS1 | 28 | ETPU.CDTRSR_A[DTRS1] | eTPUA Channel 1 Data Transfer Request Status |
| eTPU_CDTRSR_A_DTRS2 | 29 | ETPU.CDTRSR_A[DTRS2] | eTPUA Channel 2 Data Transfer Request Status |
| eTPU_CDTRSR_A_DTRS14 | 30 | ETPU.CDTRSR_A[DTRS14] | eTPUA Channel 14 Data Transfer Request Status |
| eTPU_CDTRSR_A_DTRS15 | 31 | ETPU.CDTRSR_A[DTRS15] | eTPUA Channel 15 Data Transfer Request Status |
| DSPIA_SR_TFFF | 32 | DSPIA.ISR[TFFF] | DSPIA Transmit FIFO Fill Flag |
| DSPIA_SR_RFDF | 33 | DSPIA.SR[RFDF] | DSPIA Receive FIFO Drain Flag |
| eSCIB_COMBTX | 34 | ESCIB.SR[TDRE] ESCIB.SR[TC] ESCIB.SR[TXRDY] | eSCIB combined DMA request of the Transmit Data Register Empty, Transmit Complete, and LIN Transmit Data Ready DMA requests |
| eSCIB_COMBRX | 35 | ESCIB.SR[RDRF] ESCIB.SR[RXRDY] | eSCIB combined DMA request of the Receive Data Register Full and LIN Receive Data Ready DMA requests |
| eMIOS_GFR_F6 | 36 | EMIOS.GFR[F6] | eMIOS channel 6 Flag |
| eMIOS_GFR_F7 | 37 | EMIOS.GFR[F7] | eMIOS channel 7 Flag |
| eMIOS_GFR_F10 | 38 | EMIOS.GFR[F10] | eMIOS channel 10 Flag |
| eMIOS_GFR_F11 | 39 | EMIOS.GFR[F11] | eMIOS channel 11 Flag |
| eMIOS_GFR_F16 | 40 | EMIOS.GFR[F16] | eMIOS channel 16 Flag |
| eMIOS_GFR_F17 | 41 | EMIOS.GFR[F17] | eMIOS channel 17 Flag |
| eMIOS_GFR_F18 | 42 | EMIOS.GFR[F18] | eMIOS channel 18 Flag |
| eMIOS_GFR_F19 | 43 | EMIOS.GFR[F19] | eMIOS channel 19 Flag |
| eTPU_CDTRSR_A_DTRS12 | 44 | ETPU.CDTRSR_A[DTRS12] | eTPUA Channel 12 Data Transfer Request Status |
| eTPU_CDTRSR_A_DTRS13 | 45 | ETPU.CDTRSR_A[DTRS13] | eTPUA Channel 13 Data Transfer Request Status |
| eTPU_CDTRSR_A_DTRS28 | 46 | ETPU.CDTRSR_A[DTRS28] | eTPUA Channel 28 Data Transfer Request Status |
| eTPU_CDTRSR_A_DTRS29 | 47 | ETPU.CDTRSR_A[DTRS29] | eTPUA Channel 29 Data Transfer Request Status |
| SIU_EISR{EIF0} | 48 | SIU.SIU_EISR{EIF0} | SIU External Interrupt Flag 0 |
| SIU_EISR{EIF1} | 49 | SIU.SIU_EISR{EIF1} | SIU External Interrupt Flag 1 |
| SIU_EISR{EIF2} | 50 | SIU.SIU_EISR{EIF2} | SIU External Interrupt Flag 2 |
| SIU_EISR{EIF3} | 51 | SIU.SIU_EISR{EIF3} | SIU External Interrupt Flag 3 |
| eTPU_CDTRSR_B_DTRS0 | 52 | ETPU.CDTRSR_B[DTRS0] | eTPUB Channel 0 Data Transfer Request Status |
| eTPU_CDTRSR_B_DTRS1 | 53 | ETPU.CDTRSR_B[DTRS1] | eTPUB Channel 1 Data Transfer Request Status |
| eTPU_CDTRSR_B_DTRS2 | 54 | ETPU.CDTRSR_B[DTRS2] | eTPUB Channel 2 Data Transfer Request Status |

Table 21-23. DMA Request Summary for eDMA_A (continued)

| DMA Request | Channel | Source | Description |
|----------------------|---------|-----------------------|---|
| eTPU_CDTRSR_B_DTRS3 | 55 | ETPU.CDTRSR_B[DTRS3] | eTPUB Channel 3 Data Transfer Request Status |
| eTPU_CDTRSR_B_DTRS12 | 56 | ETPU.CDTRSR_B[DTRS12] | eTPUB Channel 12 Data Transfer Request Status |
| eTPU_CDTRSR_B_DTRS13 | 57 | ETPU.CDTRSR_B[DTRS13] | eTPUB Channel 13 Data Transfer Request Status |
| eTPU_CDTRSR_B_DTRS14 | 58 | ETPU.CDTRSR_B[DTRS14] | eTPUB Channel 14 Data Transfer Request Status |
| eTPU_CDTRSR_B_DTRS15 | 59 | ETPU.CDTRSR_B[DTRS15] | eTPUB Channel 15 Data Transfer Request Status |
| eTPU_CDTRSR_B_DTRS28 | 60 | ETPU.CDTRSR_B[DTRS28] | eTPUB Channel 28 Data Transfer Request Status |
| eTPU_CDTRSR_B_DTRS29 | 61 | ETPU.CDTRSR_B[DTRS29] | eTPUB Channel 29 Data Transfer Request Status |
| eTPU_CDTRSR_B_DTRS30 | 62 | ETPU.CDTRSR_B[DTRS30] | eTPUB Channel 30 Data Transfer Request Status |
| eTPU_CDTRSR_B_DTRS31 | 63 | ETPU.CDTRSR_B[DTRS31] | eTPUB Channel 31 Data Transfer Request Status |

Table 21-24. DMA Request Summary for eDMA_B

| DMA Request | Channel | Source | Description |
|---------------------|---------|----------------------|--|
| EQADC_B_FISR0_CFFF0 | 0 | EQADC_B.FISR0[CFFF0] | EQADC_B Command FIFO 0 Fill Flag |
| EQADC_B_FISR0_RFDF0 | 1 | EQADC_B.FISR0[RFDF0] | EQADC_B Receive FIFO 0 Drain Flag |
| EQADC_B_FISR1_CFFF1 | 2 | EQADC_B.FISR1[CFFF1] | EQADC_B Command FIFO 1 Fill Flag |
| EQADC_B_FISR1_RFDF1 | 3 | EQADC_B.FISR1[RFDF1] | EQADC_B Receive FIFO 1 Drain Flag |
| EQADC_B_FISR2_CFFF2 | 4 | EQADC_B.FISR2[CFFF2] | EQADC_B Command FIFO 2 Fill Flag |
| EQADC_B_FISR2_RFDF2 | 5 | EQADC_B.FISR2[RFDF2] | EQADC_B Receive FIFO 2 Drain Flag |
| EQADC_B_FISR3_CFFF3 | 6 | EQADC_B.FISR3[CFFF3] | EQADC_B Command FIFO 3 Fill Flag |
| EQADC_B_FISR3_RFDF3 | 7 | EQADC_B.FISR3[RFDF3] | EQADC_B Receive FIFO 3 Drain Flag |
| EQADC_B_FISR4_CFFF4 | 8 | EQADC_B.FISR4[CFFF4] | EQADC_B Command FIFO 4 Fill Flag |
| EQADC_B_FISR4_RFDF3 | 9 | EQADC_B.FISR4[RFDF4] | EQADC_B Receive FIFO 4 Drain Flag |
| EQADC_B_FISR5_CFFF5 | 10 | EQADC_B.FISR5[CFFF5] | EQADC_B Command FIFO 5 Fill Flag |
| EQADC_B_FISR5_RFDF5 | 11 | EQADC_B.FISR5[RFDF5] | EQADC_B Receive FIFO 5 Drain Flag |
| DECFILTERA_IB | 12 | DECFILTERA.IB | Decimation Filter A Input Buffer Fill Flag |
| DECFILTERA_OB | 13 | DECFILTERA.OB | Decimation Filter A Output Buffer Drain Flag |
| DECFILTERB_IB | 14 | DECFILTERB.IB | Decimation Filter B Input Buffer Fill Flag |
| DECFILTERB_OB | 15 | DECFILTERB.OB | Decimation Filter B Output Buffer Drain Flag |
| DECFILTERC_IB | 16 | DECFILTERC.IB | Decimation Filter C Input Buffer Fill Flag |
| DECFILTERC_OB | 17 | DECFILTERC.OB | Decimation Filter C Output Buffer Drain Flag |
| DECFILTERD_IB | 18 | DECFILTERD.IB | Decimation Filter D Input Buffer Fill Flag |
| DECFILTERD_OB | 19 | DECFILTERD.OB | Decimation Filter D Output Buffer Drain Flag |
| DECFILTERE_IB | 20 | DECFILTERE.IB | Decimation Filter E Input Buffer Fill Flag |

Table 21-24. DMA Request Summary for eDMA_B (continued)

| DMA Request | Channel | Source | Description |
|---------------|---------|---------------|--|
| DECFILTERE_OB | 21 | DECFILTERE.OB | Decimation Filter E Output Buffer Drain Flag |
| DECFILTERF_IB | 22 | DECFILTERF.IB | Decimation Filter F Input Buffer Fill Flag |
| DECFILTERF_OB | 23 | DECFILTERF.OB | Decimation Filter F Output Buffer Drain Flag |
| DECFILTERG_IB | 24 | DECFILTERG.IB | Decimation Filter G Input Buffer Fill Flag |
| DECFILTERG_OB | 25 | DECFILTERG.OB | Decimation Filter G Output Buffer Drain Flag |
| DECFILTERH_IB | 26 | DECFILTERH.IB | Decimation Filter H Input Buffer Fill Flag |
| DECFILTERH_OB | 27 | DECFILTERH.OB | Decimation Filter H Output Buffer Drain Flag |
| No Request | 28–31 | — | — |

21.5.4 DMA Arbitration Mode Considerations

21.5.4.1 Fixed-Group Arbitration, Fixed-Channel Arbitration

In this mode, the channel service request from the highest priority channel in the highest priority group is selected to execute. If the eDMA is programmed so the channels within one group use fixed priorities, and that group is assigned the highest fixed priority of all groups, it is possible for that group to take all the bandwidth of the eDMA controller. That is, no other groups can be serviced if there is always at least one DMA request pending on a channel in the highest priority group when the controller arbitrates the next DMA request. The advantage of this scenario is that latency can be small for channels that need to be serviced quickly. Preemption is available in this scenario only.

21.5.4.2 Round-Robin Group Arbitration, Fixed-Channel Arbitration

When one or more DMA requests arrive from one or more groups, the channel with the highest priority from a specific group is serviced first. Groups are serviced starting with the highest group number with a service request and rotating through to the lowest group number containing a service request.

After the channel request is serviced, the group round robin algorithm selects the highest pending request from the next group in the round-robin sequence. Servicing continues round robin, always servicing the highest priority channel in the next group in the sequence, or skipping a group if it has no pending requests.

If a channel requests service at a rate that equals or exceeds the round robin service rate, then that channel is always serviced before lower priority channels in the same group, and the lower priority channels are never serviced. The advantage of this scenario is that no one group can consume all the eDMA bandwidth. The highest priority channel selection latency is potentially greater than fixed/fixed arbitration. Excessive request rates on high-priority channels can prevent the servicing of lower priority channels in the same group.

21.5.4.3 Round-Robin Group Arbitration, Round-Robin Channel Arbitration

Groups are serviced as described in [Section 21.5.4.2, Round-Robin Group Arbitration, Fixed-Channel Arbitration](#), but this time channels are serviced in channel number order. One channel only is serviced from each requesting group for each round robin pass through the groups.

Within each group, channels are serviced starting with the highest channel number and rotating through to the lowest channel number without regard to channel priority levels.

Because channels are serviced in round-robin manner, any channel that generates DMA requests faster than a combination of the group round-robin service rate and the channel service rate for its group does not prevent the servicing of other channels in its group. Any DMA requests that are not serviced are simply lost, but at least one channel gets serviced.

This scenario ensures that all channels are guaranteed service at some point, regardless of the request rates. However, the potential latency could be high. All channels are treated equally. Priority levels are not used in round-robin/round-robin mode.

21.5.4.4 Fixed-Group Arbitration, Round-Robin Channel Arbitration

The highest priority group with a request is serviced. Lower priority groups are serviced if no pending requests exist in the higher priority groups.

Within each group, channels are serviced starting with the highest channel number and rotating through to the lowest channel number without regard to the channel priority levels assigned within the group.

This scenario could cause the same bandwidth consumption problem as indicated in [Section 21.5.4.1, Fixed-Group Arbitration, Fixed-Channel Arbitration](#), but all the channels in the highest priority group get serviced. Service latency is short on the highest priority group, but could potentially get longer and longer as the group priority decreases.

21.5.5 DMA Transfer

21.5.5.1 Single Request

To perform a simple transfer of n bytes of data with one activation, set the major loop to 1 ($EDMA_x_TCD.CITER = EDMA_x_TCD.BITER = 1$). The data transfer begins after the channel service request is acknowledged and the channel is selected to execute. After the transfer is complete, the $EDMA_x_TCD.DONE$ bit is set and an interrupt is generated if properly enabled.

For example, the following TCD entry is configured to transfer 16 bytes of data. The eDMA is programmed for one iteration of the major loop transferring 16 bytes per iteration. The source memory has a byte wide memory port located at 0x1000. The destination memory has a word wide port located at 0x2000. The address offsets are programmed in increments to match the size of the transfer; one byte for the source and four bytes for the destination. The final source and destination addresses are adjusted to return to their beginning values.

```
EDMA_x_TCD.CITER = EDMA_x_TCD.BITER = 1
EDMA_x_TCD.NBYTES = 16
EDMA_x_TCD.SADDR = 0x1000
EDMA_x_TCD.SOFF = 1
EDMA_x_TCD.SSIZE = 0
EDMA_x_TCD.SLAST = -16
EDMA_x_TCD.DADDR = 0x2000
EDMA_x_TCD.DOFF = 4
EDMA_x_TCD.DSIZE = 2
EDMA_x_TCD.DLAST_SGA = -16
EDMA_x_TCD.INT_MAJ = 1
EDMA_x_TCD.START = 1 (Must be written last after all other fields have been initialized)
All other TCD fields = 0
```

This would generate the following sequence of events:

1. Slave write to the $EDMA_x_TCD.START$ bit requests channel service.

2. The channel is selected by arbitration for servicing.
3. eDMA engine writes: EDMA_x_TCD.DONE = 0, EDMA_x_TCD.START = 0, EDMA_x_TCD.ACTIVE = 1.
4. eDMA engine reads: channel TCD data from local memory to internal register file.
5. The source to destination transfers are executed as follows:
 - a) read_byte(0x1000), read_byte(0x1001), read_byte(0x1002), read_byte(0x1003)
 - b) write_word(0x2000) → first iteration of the minor loop
 - c) read_byte(0x1004), read_byte(0x1005), read_byte(0x1006), read_byte(0x1007)
 - d) write_word(0x2004) → second iteration of the minor loop
 - e) read_byte(0x1008), read_byte(0x1009), read_byte(0x100a), read_byte(0x100b)
 - f) write_word(0x2008) → third iteration of the minor loop
 - g) read_byte(0x100c), read_byte(0x100d), read_byte(0x100e), read_byte(0x100f)
 - h) write_word(0x200c) → last iteration of the minor loop → major loop complete
6. eDMA engine writes: EDMA_x_TCD.SADDR = 0x1000, EDMA_x_TCD.DADDR = 0x2000, EDMA_x_TCD.CITER = 1 (EDMA_x_TCD.BITER).
7. eDMA engine writes: EDMA_x_TCD.ACTIVE = 0, EDMA_x_TCD.DONE = 1, EDMA_x_IRQR_n = 1.
8. The channel retires.

The eDMA goes idle or services the next channel.

21.5.5.2 Multiple Requests

The next example is the same as previous, excepting transferring 32 bytes via two hardware requests. The only fields that change are the major loop iteration count and the final address offsets. The eDMA is programmed for two iterations of the major loop transferring 16 bytes per iteration. After the channel's hardware requests are enabled in the EDMA_x_ERQR, channel service requests are initiated by the slave device (ERQR should be set after TCD). Note that EDMA_x_TCD.START = 0.

```

EDMA_x_TCD.CITER = EDMA_x_TCD.BITER = 2
EDMA_x_TCD.NBYTES = 16
EDMA_x_TCD.SADDR = 0x1000
EDMA_x_TCD.SOFF = 1
EDMA_x_TCD.SSIZE = 0
EDMA_x_TCD.SLAST = -32
EDMA_x_TCD.DADDR = 0x2000
EDMA_x_TCD.DOFF = 4
EDMA_x_TCD.DSIZE = 2
EDMA_x_TCD.DLAST_SGA = -32
EDMA_x_TCD.INT_MAJ = 1
EDMA_x_TCD.START = 0 (Must be written last after all other fields have been initialized)

```

All other TCD fields = 0

This generates the following sequence of events:

1. First hardware (eDMA peripheral request) request for channel service.
2. The channel is selected by arbitration for servicing.
3. eDMA engine writes: EDMA_x_TCD.DONE = 0, EDMA_x_TCD.START = 0, EDMA_x_TCD.ACTIVE = 1.
4. eDMA engine reads: channel TCD data from local memory to internal register file.
5. The source to destination transfers are executed as follows:
 - a) read_byte(0x1000), read_byte(0x1001), read_byte(0x1002), read_byte(0x1003)
 - b) write_word(0x2000) → first iteration of the minor loop
 - c) read_byte(0x1004), read_byte(0x1005), read_byte(0x1006), read_byte(0x1007)
 - d) write_word(0x2004) → second iteration of the minor loop
 - e) read_byte(0x1008), read_byte(0x1009), read_byte(0x100a), read_byte(0x100b)
 - f) write_word(0x2008) → third iteration of the minor loop
 - g) read_byte(0x100c), read_byte(0x100d), read_byte(0x100e), read_byte(0x100f)
 - h) write_word(0x200c) → last iteration of the minor loop
6. eDMA engine writes: EDMA_x_TCD.SADDR = 0x1010, EDMA_x_TCD.DADDR = 0x2010, EDMA_x_TCD.CITER = 1.
7. eDMA engine writes: EDMA_x_TCD.ACTIVE = 0.
8. The channel retires → one iteration of the major loop.

The eDMA goes idle or services the next channel.

9. Second hardware (eDMA peripheral request) requests channel service.
10. The channel is selected by arbitration for servicing.
11. eDMA engine writes: EDMA_x_TCD.DONE = 0, EDMA_x_TCD.START = 0, EDMA_x_TCD.ACTIVE = 1.
12. eDMA engine reads: channel TCD data from local memory to internal register file.
13. The source to destination transfers are executed as follows:
 - a) read_byte(0x1010), read_byte(0x1011), read_byte(0x1012), read_byte(0x1013)
 - b) write_word(0x2010) → first iteration of the minor loop
 - c) read_byte(0x1014), read_byte(0x1015), read_byte(0x1016), read_byte(0x1017)
 - d) write_word(0x2014) → second iteration of the minor loop
 - e) read_byte(0x1018), read_byte(0x1019), read_byte(0x101a), read_byte(0x101b)
 - f) write_word(0x2018) → third iteration of the minor loop
 - g) read_byte(0x101c), read_byte(0x101d), read_byte(0x101e), read_byte(0x101f)
 - h) write_word(0x201c) → last iteration of the minor loop → major loop complete
14. eDMA engine writes: EDMA_x_TCD.SADDR = 0x1000, EDMA_x_TCD.DADDR = 0x2000, EDMA_x_TCD.CITER = 2 (EDMA_x_TCD.BITER).

15. eDMA engine writes: EDMA_x_TCD.ACTIVE = 0, EDMA_x_TCD.DONE = 1, EDMA_x_IRQRn = 1.
16. The channel retires → major loop complete.

The eDMA goes idle or services the next channel.

21.5.5.3 Modulo Feature

The modulo feature of the eDMA provides the ability to implement a circular data queue in which the size of the queue is a power of two. MOD is a 5-bit bitfield for both the source and destination in the TCD and specifies which lower address bits are allowed to increment from their original value after the address + offset calculation. All upper address bits remain the same as in the original value. A setting of 0 for this field disables the modulo feature.

Table 21-25 shows how the transfer addresses are specified based on the setting of the MOD field. Here a circular buffer is created where the address wraps to the original value while the 28 upper address bits (0x1234567x) retain their original value. In this example the source address is set to 0x12345670, the offset is set to 4 bytes and the mod field is set to 4, allowing for a 2⁴ byte (16-byte) size queue.

Table 21-25. Modulo Feature Example

| Transfer Number | Address |
|-----------------|------------|
| 1 | 0x12345670 |
| 2 | 0x12345674 |
| 3 | 0x12345678 |
| 4 | 0x1234567C |
| 5 | 0x12345670 |
| 6 | 0x12345674 |

21.5.6 TCD Status

21.5.6.1 Minor Loop Complete

There are two methods to test for minor loop completion when using software initiated service requests. The first method is to read the EDMA_x_TCD.CITER field and test for a change. Another method may be extracted from the sequence below. The second method is to test the EDMA_x_TCD.START bit AND the EDMA_x_TCD.ACTIVE bit. The minor loop complete condition is indicated by both bits reading zero after the EDMA_x_TCD.START was written to a 1. Polling the EDMA_x_TCD.ACTIVE bit may be inconclusive because the active status may be missed if the channel execution is short in duration.

The TCD status bits execute the following sequence for a software activated channel:

1. EDMA_x_TCD.START = 1, EDMA_x_TCD.ACTIVE = 0, EDMA_x_TCD.DONE = 0 (channel service request via software).

2. EDMA_x_TCD.START = 0, EDMA_x_TCD.ACTIVE = 1, EDMA_x_TCD.DONE = 0 (channel is executing).
3. EDMA_x_TCD.START = 0, EDMA_x_TCD.ACTIVE = 0, EDMA_x_TCD.DONE = 0 (channel has completed the minor loop and is idle), or
4. EDMA_x_TCD.START = 0, EDMA_x_TCD.ACTIVE = 0, EDMA_x_TCD.DONE = 1 (channel has completed the major loop and is idle).

The best method to test for minor loop completion when using hardware initiated service requests is to read the EDMA_x_TCD.CITER field and test for a change. The hardware request and acknowledge handshakes signals are not visible in the programmer's model.

The TCD status bits execute the following sequence for a hardware activated channel:

1. eDMA peripheral request asserts (channel service request via hardware).
2. EDMA_x_TCD.START = 0, EDMA_x_TCD.ACTIVE = 1, EDMA_x_TCD.DONE = 0 (channel is executing).
3. EDMA_x_TCD.START = 0, EDMA_x_TCD.ACTIVE = 0, EDMA_x_TCD.DONE = 0 (channel has completed the minor loop and is idle), or
4. EDMA_x_TCD.START = 0, EDMA_x_TCD.ACTIVE = 0, EDMA_x_TCD.DONE = 1 (channel has completed the major loop and is idle).

For both activation types, the major loop complete status is explicitly indicated via the EDMA_x_TCD.DONE bit.

The EDMA_x_TCD.START bit is cleared automatically when the channel begins execution, regardless of how the channel was activated.

21.5.6.2 Active Channel TCD Reads

The eDMA will read back the true EDMA_x_TCD.SADDR, EDMA_x_TCD.DADDR, and EDMA_x_TCD.NBYTES values if read while a channel is executing. The true values of the SADDR, DADDR, and NBYTES are the values the eDMA engine is currently using in its internal register file and not the values in the TCD local memory for that channel. The addresses (SADDR and DADDR) and NBYTES (decrements to zero as the transfer progresses) can give an indication of the progress of the transfer. All other values are read back from the TCD local memory.

21.5.6.3 Preemption Status

Preemption is available only when fixed arbitration is selected for both group- and channel-arbitration modes. A preempt-able situation is one in which a preempt-enabled channel is running and a higher priority request becomes active. When the eDMA engine is not operating in fixed group, fixed-channel arbitration mode, the determination of the relative priority of the actively running and the outstanding requests become undefined. Channel and group priorities are treated as equal (or more exactly, constantly rotating) when round-robin arbitration mode is selected.

The EDMA_x_TCD.ACTIVE bit for the preempted channel remains asserted throughout the preemption. The preempted channel is temporarily suspended while the preempting channel executes one iteration of

the major loop. Two EDMA_x_TCD.ACTIVE bits set at the same time in the overall TCD map indicates a higher priority channel is actively preempting a lower priority channel.

21.5.7 Channel Linking

Channel linking (or chaining) is a mechanism in which one channel sets the EDMA_x_TCD.START bit of another channel (or itself), thus initiating a service request for that channel. This operation is automatically performed by the eDMA engine at the conclusion of the major or minor loop when properly enabled.

The minor loop channel linking occurs at the completion of the minor loop (or one iteration of the major loop). The EDMA_x_TCD.CITER.E_LINK field are used to determine whether a minor loop link is requested. When enabled, the channel link is made after each iteration of the minor loop except for the last. When the major loop is exhausted, only the major loop channel link fields are used to determine if a channel link should be made. For example, with the initial fields of:

```
EDMA_x_TCD.CITER.E_LINK = 1
EDMA_x_TCD.CITER.LINKCH = 0xC
EDMA_x_TCD.CITER value = 0x4
EDMA_x_TCD.MAJOR.E_LINK = 1
EDMA_x_TCD.MAJOR.LINKCH = 0x7
```

will execute as:

1. Minor loop done → set channel 12 EDMA_x_TCD.START bit
2. Minor loop done → set channel 12 EDMA_x_TCD.START bit
3. Minor loop done → set channel 12 EDMA_x_TCD.START bit
4. Minor loop done, major loop done → set channel 7 EDMA_x_TCD.START bit

When minor loop linking is enabled (EDMA_x_TCD.CITER.E_LINK = 1), the EDMA_x_TCD.CITER field uses a nine bit vector to form the current iteration count.

When minor loop linking is disabled (EDMA_x_TCD.CITER.E_LINK = 0), the EDMA_x_TCD.CITER field uses a 15-bit vector to form the current iteration count. The bits associated with the EDMA_x_TCD.CITER.LINKCH field are concatenated onto the CITER value to increase the range of the CITER.

NOTE

After configuration, the EDMA_x_TCD.CITER.E_LINK bit and the EDMA_x_TCD.BITER.E_LINK bit must be equal or a configuration error is reported. The CITER and BITER vector widths must be equal to calculate the major loop, halfway done interrupt point.

[Table 21-26](#) summarizes how a DMA channel can link to another DMA channel, i.e., use another channel's TCD, at the end of a loop.

Table 21-26. Channel Linking Parameters

| Desired Link Behavior | TCD Control Field Name | Description |
|---------------------------|------------------------|---|
| Link at end of minor loop | citer.e_link | Enable channel-to-channel linking on minor loop completion (current iteration). |
| | citer.linkch | Link channel number when linking at end of minor loop (current iteration). |
| Link at end of major loop | major.e_link | Enable channel-to-channel linking on major loop completion. |
| | major.linkch | Link channel number when linking at end of major loop. |

21.5.8 Dynamic Programming

This section provides recommended methods to change the programming model during channel execution.

21.5.8.1 Dynamic Channel Linking and Dynamic Scatter-Gather Operation

Dynamic channel linking and dynamic scatter-gather operation is the process of changing the EDMA_x_TCD.MAJOR.E_LINK or EDMA_x_TCD.E_SG bits during channel execution. These bits are read from the TCD local memory at the end of channel execution thus allowing the user to enable either feature during channel execution.

Because the user is allowed to change the configuration during execution, a coherency model is needed. Consider a scenario where the user attempts to execute a dynamic channel link by enabling the EDMA_x_TCD.MAJOR.E_LINK bit at the same time the eDMA engine is retiring the channel. The EDMA_x_TCD.MAJOR.E_LINK would be set in the programmer's model, but it would be unclear whether the actual link was made before the channel retired.

The following coherency model is recommended when executing a dynamic channel link or dynamic scatter-gather request:

1. Set the EDMA_x_TCD.MAJOR.E_LINK bit.
2. Read back the EDMA_x_TCD.MAJOR.E_LINK bit
3. Test the EDMA_x_TCD.MAJOR.E_LINK request status:
 - a) If the bit is set, the dynamic link attempt was successful.
 - b) If the bit is cleared, the attempted dynamic link did not succeed, the channel was already retiring.

This same coherency model is true for dynamic scatter-gather operations. For both dynamic requests, the TCD local memory controller forces the EDMA_x_TCD.MAJOR.E_LINK and EDMA_x_TCD.E_SG bits to zero on any writes to a channel's TCD after that channel's EDMA_x_TCD.DONE bit is set indicating the major loop is complete.

NOTE

The user must clear the EDMA_x_TCD.DONE bit before writing the EDMA_x_TCD.MAJOR.E_LINK or EDMA_x_TCD.E_SG bits. The EDMA_x_TCD.DONE bit is cleared automatically by the eDMA engine after a channel begins execution.

Chapter 22 FlexRay Communication Controller (FLEXRAY)

22.1 Introduction

22.1.1 Reference

The following documents are referenced.

- *FlexRay Communications System Protocol Specification, Version 2.1 Rev A*
- *FlexRay Communications System Electrical Physical Layer Specification, Version 2.1 Rev A*

22.1.2 Glossary

This section provides a list of terms used in the description of the controller.

Table 22-1. List of Terms

| Term | Definition |
|-------------------------------|--|
| BCU | Buffer Control Unit. Handles message buffer access. |
| BMIF | Bus Master Interface. Provides master access to FlexRay Memory block. |
| CC | Communication Controller |
| CDC | Clock Domain Crosser |
| CHI | Controller Host Interface |
| Cycle length in μT | The actual length of a cycle in μT for the ideal controller (+/- 0 ppm) |
| EBI | External Bus Interface |
| FlexRay Memory | Memory Window to store message buffer payload, header, status, and synchronization frame related tables. |
| System Memory | Memory that is contains the FlexRay Memory |
| System Bus | Bus that connects the controller and System Memory |
| FSS | Frame Start Sequence |
| HIF | Host Interface. Provides host access to controller. |
| Host | The FlexRay CC host MCU |
| LUT | Look Up Table. Stores message buffer header index value. |
| MB | Message Buffer |
| MBIDX | Message Buffer Index: the position of a header field entry within the header area. If the header area is accessed as an array, this is the same as the array index of the entry. |
| MNum | Message Buffer Number: Position of message buffer configuration registers within the register map. For example, Message Buffer Number 5 corresponds to the MBCCS5 register. |
| MCU | Microcontroller Unit |
| μT | Microtick |
| MT | Macrotick |

Table 22-1. List of Terms (continued)

| Term | Definition |
|---------------|---|
| MTS | Media Access Test Symbol |
| NIT | Network Idle Time |
| PE | Protocol Engine |
| POC | Protocol Operation Control. Each state of the POC is denoted by <i>POC:state</i> |
| Rx | Reception |
| SEQ | Sequencer Engine |
| TCU | Time Control Unit |
| Tx | Transmission |
| sync frame | null frame or message frame with <i>Sync Frame Indicator</i> set to 1 |
| startup frame | null frame or message frame with both <i>Sync Frame Indicator</i> and <i>Startup Frame Indicator</i> set to 1 |
| normal frame | null frame or message frame with both <i>Sync Frame Indicator</i> and <i>Startup Frame Indicator</i> set to 0 |
| null frame | frame with <i>Null Frame Indicator</i> set to 0 |
| message frame | frame with <i>Null Frame Indicator</i> set to 1 |

22.1.3 Color Coding

Throughout this chapter types of items are highlighted through the use of an italicized color font.

FlexRay protocol parameters, constants and variables are highlighted with *blue italics*. An example is the parameter *gdActionPointOffset*.

FlexRay protocol states are highlighted in *green italics*. An example is the state *POC:normal active*.

22.1.4 Overview

The controller is a FlexRay communication controller that implements the *FlexRay Communications System Protocol Specification, Version 2.1 Rev A*.

The controller has three main components:

- Controller host interface (CHI)
- Protocol engine (PE)
- Clock domain crossing unit (CDC)

A block diagram of the controller with its surrounding modules is given in [Figure 22-1](#).

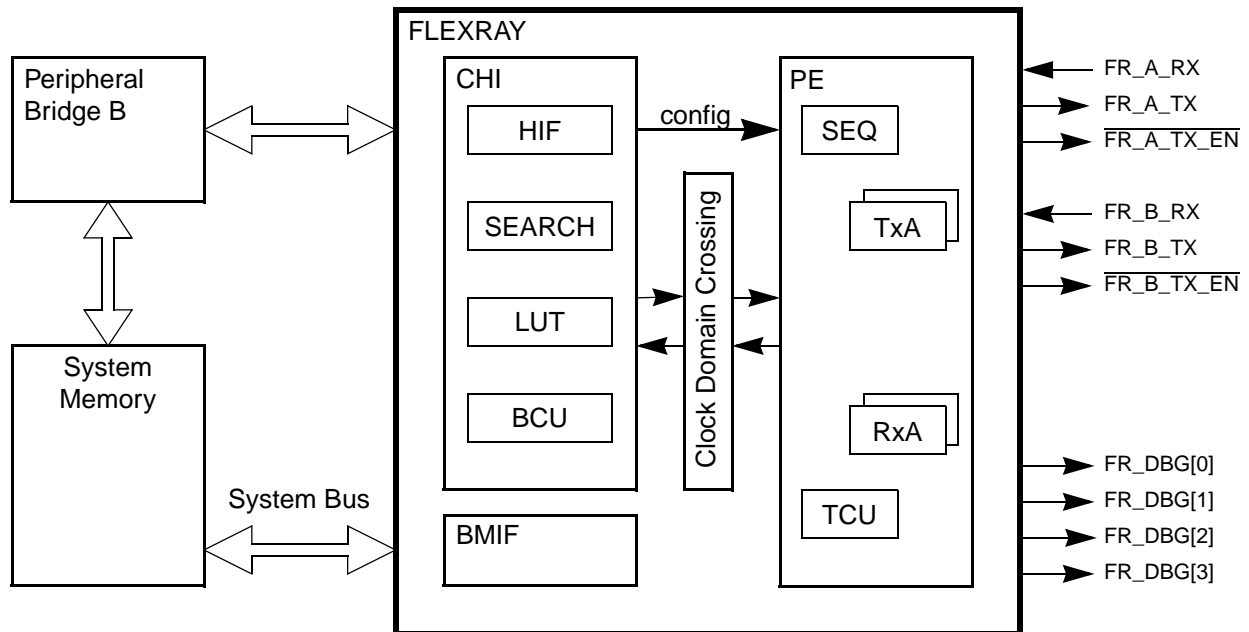

Figure 22-1. FLEXRAY Block Diagram

The protocol engine has two transmitter units TxA and TxB and two receiver units RxA and RxB for sending and receiving frames through the two FlexRay channels. The time control unit (TCU) is responsible for maintaining global clock synchronization to the FlexRay network. The overall activity of the PE is controlled by the sequencer engine (SEQ).

The controller host interface provides host access to the module's configuration, control, and status registers, as well as to the message buffer configuration, control, and status registers. The message buffers themselves, which contain the frame header and payload data received or to be transmitted, and the slot status information, are stored in the flexray memory.

The clock domain crossing unit implements signal crossing from the CHI clock domain to the PE clock domain and vice versa, to allow for asynchronous PE and CHI clock domains.

The controller stores the frame header and payload data of frames received or of frames to be transmitted in the flexray memory. The application accesses the flexray memory to retrieve and provide the frames to be processed by the controller. In addition to the frame header and payload data, the controller stores the synchronization frame related tables in the flexray memory for application processing.

The flexray memory is located in the system memory of the MCU. The controller has access to the flexray memory via its bus master interface (BMIF). The host provides the start address of the flexray memory window within the system memory by programming the [System Memory Base Address Register \(SYMBADR\)](#). All flexray memory related offsets are stored in offset registers. The physical address pointer into the flexray memory window of the MCU system memory is calculated using the offset values the flexray memory base address.

NOTE

The controller does not provide a memory protection scheme for the flexray memory.

22.1.5 Features

The controller provides the following features:

- *FlexRay Communications System Protocol Specification, Version 2.1 Rev A* compliant protocol implementation
- *FlexRay Communications System Electrical Physical Layer Specification, Version 2.1 Rev A* compliant bus driver interface
- single channel support
 - FlexRay Port A can be configured to be connected either to physical FlexRay channel A or physical FlexRay channel B.
- FlexRay bus data rates of 10 Mbit/s, 8 Mbit/s, 5 Mbit/s, and 2.5 Mbit/s supported
- 128 configurable message buffers with
 - individual frame ID filtering
 - individual channel ID filtering
 - individual cycle counter filtering
- message buffer header, status and payload data stored in dedicated flexray memory
 - allows for flexible and efficient message buffer implementation
 - consistent data access ensured by means of buffer locking scheme
 - application can lock multiple buffers at the same time
- size of message buffer payload data section configurable from 0 up to 254 bytes
- two independent message buffer segments with configurable size of payload data section
 - each segment can contain message buffers assigned to the static segment and message buffers assigned to the dynamic segment at the same time
- zero padding for transmit message buffers in static segment
 - applied when the frame payload length exceeds the size of the message buffer data section
- transmit message buffers configurable with state/event semantics
- message buffers can be configured as
 - receive message buffer
 - single buffered transmit message buffer
 - double buffered transmit message buffer (combines two single buffered message buffer)
- individual message buffer reconfiguration supported
 - means provided to safely disable individual message buffers
 - disabled message buffers can be reconfigured
- two independent receive FIFOs
 - one receive FIFO per channel
 - up to 255 entries for each FIFO

- global frame ID filtering, based on both value/mask filters and range filters
- global channel ID filtering
- global message ID filtering for the dynamic segment
- 4 configurable slot error counters
- 4 dedicated slot status indicators
 - used to observe slots without using receive message buffers
- measured value indicators for the clock synchronization
 - internal synchronization frame ID and synchronization frame measurement tables can be copied into the flexray memory
- fractional macroticks are supported for clock correction
- maskable interrupt sources provided via individual and combined interrupt lines
- 1 absolute timer
- 1 timer that can be configured to absolute or relative

22.1.6 Modes of Operation

This section describes the basic operational power modes of the controller.

22.1.6.1 Disabled Mode

The controller enters the Disabled Mode during hard reset. The controller indicates that it is in the Disabled Mode by negating the module enable bit MEN in the [Module Configuration Register \(MCR\)](#).

No communication is performed on the FlexRay bus.

All registers with the write access conditions *Any Time* and *Disabled Mode* can be accessed for writing as stated in [Section 22.5.2, Register Descriptions](#).

The application configures the controller by accessing the configuration bits and fields in the [Module Configuration Register \(MCR\)](#).

22.1.6.1.1 Leave Disabled Mode

The controller leaves the Disabled Mode and enters the Normal Mode, when the application writes 1 to the module enable bit MEN in the [Module Configuration Register \(MCR\)](#)

NOTE

When the controller was enabled, it cannot be disabled the later on.

22.1.6.2 Normal Mode

In this mode the controller is fully functional. The controller indicates that it is in Normal Mode by asserting the module enable bit MEN in the [Module Configuration Register \(MCR\)](#).

22.1.6.2.1 Enter Normal Mode

This mode is entered when the application requests the controller to leave the Disabled Mode. If the Normal Mode was entered by leaving the Disabled Mode, the application has to perform the protocol initialization described in [Section 22.7.1.2, Protocol Initialization](#), to achieve full FlexRay functionality.

Depending on the values of the SCM, CHA, and CHB bits in the [Module Configuration Register \(MCR\)](#), the corresponding FlexRay bus driver ports are enabled and driven.

22.2 External Signal Description

This section lists and describes the controller signals, connected to external pins. These signals are summarized in [Table 22-2](#) and described in detail in [Section 22.2.1, Detailed Signal Descriptions](#).

NOTE

The off chip signals FR_A_RX, FR_A_TX, and $\overline{\text{FR_A_TX_EN}}$ are available on each package option. The availability of the other off chip signals depends on the package option.

Table 22-2. External Signal Properties

| Name | Direction | Active | Reset | Function |
|-----------------------------------|-----------|--------|-------|---------------------------|
| FR_A_RX | Input | — | — | Receive Data Channel A |
| FR_A_TX | Output | — | 1 | Transmit Data Channel A |
| $\overline{\text{FR_A_TX_EN}}$ | Output | Low | 1 | Transmit Enable Channel A |
| FR_B_RX | Input | — | — | Receive Data Channel B |
| FR_B_TX | Output | — | 1 | Transmit Data Channel B |
| $\overline{\text{FR_B_TX_EN}}$ | Output | Low | 1 | Transmit Enable Channel B |
| FR_DBG[0] | Output | — | 0 | Debug Strobe Signal 0 |
| FR_DBG[1] | Output | — | 0 | Debug Strobe Signal 1 |
| FR_DBG[2] | Output | — | 0 | Debug Strobe Signal 2 |
| FR_DBG[3] | Output | — | 0 | Debug Strobe Signal 3 |

22.2.1 Detailed Signal Descriptions

This section provides a detailed description of the controller signals, connected to external pins.

22.2.1.1 FR_A_RX — Receive Data Channel A

The FR_A_RX signal carries the receive data for channel A from the corresponding FlexRay bus driver.

22.2.1.2 FR_A_TX — Transmit Data Channel A

The FR_A_TX signal carries the transmit data for channel A to the corresponding FlexRay bus driver.

22.2.1.3 $\overline{\text{FR_A_TX_EN}}$ — Transmit Enable Channel A

The $\overline{\text{FR_A_TX_EN}}$ signal indicates to the FlexRay bus driver that the controller is attempting to transmit data on channel A.

22.2.1.4 FR_B_RX — Receive Data Channel B

The FR_B_RX signal carries the receive data for channel B from the corresponding FlexRay bus driver.

22.2.1.5 FR_B_TX — Transmit Data Channel B

The FR_B_TX signal carries the transmit data for channel B to the corresponding FlexRay bus driver

22.2.1.6 $\overline{\text{FR_B_TX_EN}}$ — Transmit Enable Channel B

The $\overline{\text{FR_B_TX_EN}}$ signal indicates to the FlexRay bus driver that the controller is attempting to transmit data on channel B.

22.2.1.7 $\text{FR_DBG}[3]$, $\text{FR_DBG}[2]$, $\text{FR_DBG}[1]$, $\text{FR_DBG}[0]$ — Strobe Signals

These signals provide the selected debug strobe signals. For details on the debug strobe signal selection refer to [Section 22.6.16, Strobe Signal Support](#).

22.3 Controller Host Interface Clocking

The clock for the CHI is derived from the system bus clock and has the same phase and frequency as the system bus clock. Since the FlexRay protocol requires data delivery at fixed points in time, the memory read cycles from the flexray memory must be finished after a fixed amount of time. To ensure this, a minimum frequency f_{chi} of the CHI clock is required, which is given in [Equation 22-1](#).

$$f_{\text{chi}} \geq 32\text{MHz} \quad \text{Eqn. 22-1}$$

Additional requirements for the minimum frequency of the CHI clock result from the number of message buffers. These requirements are provided in [Section 22.7.3, Number of Usable Message Buffers](#).

22.4 Protocol Engine Clocking

The clock for the protocol engine can be generated by two sources. The first source is the internal crystal oscillator and the second source is an internal PLL. The clock source to be used is selected by the clock source select bit CLKSEL in the [Module Configuration Register \(MCR\)](#).

22.4.1 Oscillator Clocking

If the protocol engine is clocked by the internal crystal oscillator, an 40 MHz crystal or CMOS compatible clock must be connected to the oscillator pins. The crystal or clock must fulfill the requirements given by the *FlexRay Communications System Protocol Specification, Version 2.1 Rev A*.

22.4.2 PLL Clocking

If the protocol engine is clocked by the internal PLL, the frequency of the PE clock source is system clock / 3. The system clock frequency has to be 120 MHz.

22.5 Memory Map and Register Description

The controller occupies 1280 bytes of address space starting at the controller's base address defined by the memory map of the MCU.

22.5.1 Memory Map

The complete memory map of the controller is shown in [Table 22-3](#). The addresses presented here are the offsets relative to the controller base address which is defined by the MCU address map.

Table 22-3. FlexRay Memory Map

| Offset | Register | Access |
|---|--|--------|
| Module Configuration and Control | | |
| 0x0000 | Module Version Register (MVR) | R |
| 0x0002 | Module Configuration Register (MCR) | R/W |
| 0x0004 | System Memory Base Address High Register (SYMBADHR) | R/W |
| 0x0006 | System Memory Base Address Low Register (SYMBADLR) | R/W |
| 0x0008 | Strobe Signal Control Register (STBSCR) | R/W |
| 0x000A | Reserved | R |
| 0x000C | Message Buffer Data Size Register (MBDSR) | R/W |
| 0x000E | Message Buffer Segment Size and Utilization Register (MBSSUTR) | R/W |
| Test Registers | | |
| 0x0010 | Reserved | R |
| 0x0012 | Reserved | R |
| Interrupt and Error Handling | | |
| 0x0014 | Protocol Operation Control Register (POCR) | R/W |
| 0x0016 | Global Interrupt Flag and Enable Register (GIFER) | R/W |
| 0x0018 | Protocol Interrupt Flag Register 0 (PIFR0) | R/W |
| 0x001A | Protocol Interrupt Flag Register 1 (PIFR1) | R/W |
| 0x001C | Protocol Interrupt Enable Register 0 (PIER0) | R/W |
| 0x001E | Protocol Interrupt Enable Register 1 (PIER1) | R/W |
| 0x0020 | CHI Error Flag Register (CHIERFR) | R/W |
| 0x0022 | Message Buffer Interrupt Vector Register (MBIVEC) | R |
| 0x0024 | Channel A Status Error Counter Register (CASERCR) | R |
| 0x0026 | Channel B Status Error Counter Register (CBSECR) | R |
| Protocol Status | | |
| 0x0028 | Protocol Status Register 0 (PSR0) | R |
| 0x002A | Protocol Status Register 1 (PSR1) | R |
| 0x002C | Protocol Status Register 2 (PSR2) | R |

Table 22-3. FlexRay Memory Map (continued)

| Offset | Register | Access |
|--------------------------------------|--|--------|
| 0x002E | Protocol Status Register 3 (PSR3) | R/W |
| 0x0030 | Macrotick Counter Register (MTCTR) | R |
| 0x0032 | Cycle Counter Register (CYCTR) | R |
| 0x0034 | Slot Counter Channel A Register (SLCTAR) | R |
| 0x0036 | Slot Counter Channel B Register (SLCTBR) | R |
| 0x0038 | Rate Correction Value Register (RTCORVR) | R |
| 0x003A | Offset Correction Value Register (OFCORVR) | R |
| 0x003C | Combined Interrupt Flag Register (CIFRR) | R |
| 0x003E | System Memory Access Time-Out Register (SYMATOR) | R/W |
| Sync Frame Counter and Tables | | |
| 0x0040 | Sync Frame Counter Register (SFCNTR) | R |
| 0x0042 | Sync Frame Table Offset Register (SFTOR) | R/W |
| 0x0044 | Sync Frame Table Configuration, Control, Status Register (SFTCCSR) | R/W |
| Sync Frame Filter | | |
| 0x0046 | Sync Frame ID Rejection Filter Register (SFIDRFR) | R/W |
| 0x0048 | Sync Frame ID Acceptance Filter Value Register (SFIDAFVR) | R/W |
| 0x004A | Sync Frame ID Acceptance Filter Mask Register (SFIDAFMR) | R/W |
| Network Management Vector | | |
| 0x004C | Network Management Vector Register 0 (NMVR0) | R |
| 0x004E | Network Management Vector Register 1 (NMVR1) | R |
| 0x0050 | Network Management Vector Register 2 (NMVR2) | R |
| 0x0052 | Network Management Vector Register 3 (NMVR3) | R |
| 0x0054 | Network Management Vector Register 4 (NMVR4) | R |
| 0x0056 | Network Management Vector Register 5 (NMVR5) | R |
| 0x0058 | Network Management Vector Length Register (NMVLR) | R/W |
| Timer Configuration | | |
| 0x005A | Timer Configuration and Control Register (TICCR) | R/W |
| 0x005C | Timer 1 Cycle Set Register (T1CYSR) | R/W |
| 0x005E | Timer 1 Macrotick Offset Register (T1MTOR) | R/W |
| 0x0060 | Timer 2 Configuration Register 0 (TI2CR0) | R/W |
| 0x0062 | Timer 2 Configuration Register 1 (TI2CR1) | R/W |
| Slot Status Configuration | | |
| 0x0064 | Slot Status Selection Register (SSSR) | R/W |
| 0x0066 | Slot Status Counter Condition Register (SSCCR) | R/W |
| Slot Status | | |
| 0x0068 | Slot Status Register 0 (SSR0) | R |
| 0x006A | Slot Status Register 1 (SSR1) | R |
| 0x006C | Slot Status Register 2 (SSR2) | R |
| 0x006E | Slot Status Register 3 (SSR3) | R |
| 0x0070 | Slot Status Register 4 (SSR4) | R |
| 0x0072 | Slot Status Register 5 (SSR5) | R |

Table 22-3. FlexRay Memory Map (continued)

| Offset | Register | Access |
|---|--|--------|
| 0x0074 | Slot Status Register 6 (SSR6) | R |
| 0x0076 | Slot Status Register 7 (SSR7) | R |
| 0x0078 | Slot Status Counter Register 0 (SSCR0) | R |
| 0x007A | Slot Status Counter Register 1 (SSCR1) | R |
| 0x007C | Slot Status Counter Register 2 (SSCR2) | R |
| 0x007E | Slot Status Counter Register 3 (SSCR3) | R |
| MTS Generation | | |
| 0x0080 | MTS A Configuration Register (MTSACFR) | R/W |
| 0x0082 | MTS B Configuration Register (MTSBCFR) | R/W |
| Shadow Buffer Configuration | | |
| 0x0084 | Receive Shadow Buffer Index Register (RSBIR) | R/W |
| Receive FIFO — Configuration | | |
| 0x0086 | Receive FIFO Watermark and Selection Register (RFWMSR) | R/W |
| 0x0088 | Receive FIFO Start Index Register (RFSIR) | R/W |
| 0x008A | Receive FIFO Depth and Size Register (RFDSR) | R/W |
| Receive FIFO - Control | | |
| 0x008C | Receive FIFO A Read Index Register (RFARIR) | R |
| 0x008E | Receive FIFO B Read Index Register (RFBIR) | R |
| Receive FIFO - Filter | | |
| 0x0090 | Receive FIFO Message ID Acceptance Filter Value Register (RFMIDAFVR) | R/W |
| 0x0092 | Receive FIFO Message ID Acceptance Filter Mask Register (RFMIAFMR) | R/W |
| 0x0094 | Receive FIFO Frame ID Rejection Filter Value Register (RFFIDRFVR) | R/W |
| 0x0096 | Receive FIFO Frame ID Rejection Filter Mask Register (RFFIDRFMR) | R/W |
| 0x0098 | Receive FIFO Range Filter Configuration Register (RFRFCFR) | R/W |
| 0x009A | Receive FIFO Range Filter Control Register (RFRFCTR) | R/W |
| Dynamic Segment Status | | |
| 0x009C | Last Dynamic Transmit Slot Channel A Register (LDTXSLAR) | R |
| 0x009E | Last Dynamic Transmit Slot Channel B Register (LDTXSLBR) | R |
| Protocol Configuration | | |
| 0x00A0 | Protocol Configuration Register 0 (PCR0) | R/W |
| ... | ... | - |
| 0x00DC | Protocol Configuration Register 30 (PCR30) | R/W |
| 0x00DE | Reserved | R |
| ... | | |
| 0x00E6 | | |
| Receive FIFO — Configuration (cont.) | | |
| 0x00E8 | Receive FIFO System Memory Base Address High Register (RFSYMBADHR) | R/W |
| 0x00EA | Receive FIFO System Memory Base Address Low Register (RFSYMBADLR) | R/W |
| 0x00EC | Receive FIFO Periodic Timer Register (RFPTR) | R/W |
| Receive FIFO - Control (cont.) | | |
| 0x00EE | Receive FIFO Fill Level and POP Count Register (RFFLPCR) | R/W |

Table 22-3. FlexRay Memory Map (continued)

| Offset | Register | Access |
|---|--|--------|
| 0x00F0 ... 0x00FE | Reserved | R |
| Message Buffers Configuration, Control, Status | | |
| 0x0100 | Message Buffer Configuration, Control, Status Register 0 (MBCCSR0) | R/W |
| 0x0102 | Message Buffer Cycle Counter Filter Register 0 (MBCCFR0) | R/W |
| 0x0104 | Message Buffer Frame ID Register 0 (MBFIDR0) | R/W |
| 0x0106 | Message Buffer Index Register 0 (MBIDXR0) | R/W |
| ... | ... | ... |
| 0x04F8 | Message Buffer Configuration, Control, Status Register 127 (MBCCSR127) | R/W |
| 0x04FA | Message Buffer Cycle Counter Filter Register 127 (MBCCFR127) | R/W |
| 0x04FC | Message Buffer Frame ID Register 127 (MBFIDR127) | R/W |
| 0x04FE | Message Buffer Index Register 127 (MBIDXR127) | R/W |

22.5.2 Register Descriptions

This section provides detailed descriptions of all registers in ascending address order, presented as 16-bit wide entities

[Table 22-4](#) provides a key for the register figures and register tables.

Table 22-4. Register Access Conventions

| Convention | Description |
|-----------------------------|--|
| | Depending on its placement in the read or write row, indicates that the bit is not readable or not writeable. |
| R* | Reserved bit or field, will not be changed. Application must not write any value different from the reset value. |
| FIELDNAME | Identifies the field. Its presence in the read or write row indicates that it can be read or written. |
| Register Field Types | |
| rwm | A read/write bit that may be modified by a hardware in some fashion other than by a reset. |
| w1c | Write one to clear. A flag bit that can be read, is cleared by writing a one, writing 0 has no effect. |
| Reset Value | |
| 0 | Resets to zero. |
| 1 | Resets to one. |
| – | Not defined after reset and not affected by reset. |

22.5.2.1 Register Reset

All registers except the [Message Buffer Cycle Counter Filter Registers \(MBCCFRn\)](#), [Message Buffer Frame ID Registers \(MBFIDRn\)](#), and [Message Buffer Index Registers \(MBIDXRn\)](#) are reset to their reset value on system reset. The registers mentioned above are located in physical memory blocks and, thus, they are not affected by reset. For some register fields, additional reset conditions exist. These additional

reset conditions are mentioned in the detailed description of the register. The additional reset conditions are explained in [Table 22-5](#).

Table 22-5. Additional Register Reset Conditions

| Condition | Description |
|------------------------|--|
| Protocol RUN Command | The register field is reset when the application writes to RUN command “0101” to the POCCMD field in the Protocol Operation Control Register (POCR) . |
| Message Buffer Disable | The register field is reset when the application has disabled the message buffer. This happens when the application writes 1 to the message buffer disable trigger bit MBCCSRn[EDT] while the message buffer is enabled (MBCCSn[EDS] = 1) and the controller grants the disable to the application by clearing the MBCCSRn[EDS] bit. |

22.5.2.2 Register Write Access

This section describes the write access restriction terms that apply to all registers.

22.5.2.2.1 Register Write Access Restriction

For each register bit and register field, the write access conditions are specified in the detailed register description. A description of the write access conditions is given in [Table 22-6](#). If, for a specific register bit or field, none of the given write access conditions is fulfilled, any write attempt to this register bit or field is ignored without any notification. The values of the bits or fields are not changed. The condition term [A or B] indicates that the register or field can be written to if at least one of the conditions is fulfilled.

Table 22-6. Register Write Access Restrictions

| Condition | Indication | Description |
|-------------------|-------------------------------------|--|
| Any Time | — | No write access restriction. |
| Disabled Mode | MCR[MEN] = 0 | Write access only when the controller is in Disabled Mode. |
| Normal Mode | MCR[MEN] = 1 | Write access only when the controller is in Normal Mode. |
| <i>POC:config</i> | PSR0[PROTSTATE] = <i>POC:config</i> | Write access only when the Protocol is in the <i>POC:config</i> state. |
| MB_DIS | MBCCSR[EDS] = 0 | Write access only when the related Message Buffer is disabled. |
| MB_LCK | MBCCSRn[LCKS] = 1 | Write access only when the related Message Buffer is locked. |

22.5.2.2.2 Register Write Access Requirements

All registers can be accessed with 8-bit, 16-bit and 32-bit wide operations. For some of the registers, at least a 16-bit wide write access is required to ensure correct operation. This write access requirement is stated in the detailed register description for each register affected

22.5.2.2.3 Internal Register Access

The following memory mapped registers are used to access multiple internal registers.

- [Strobe Signal Control Register \(STBSCR\)](#)
- [Slot Status Selection Register \(SSSR\)](#)
- [Slot Status Counter Condition Register \(SSCCR\)](#)
- [Receive Shadow Buffer Index Register \(RSBIR\)](#)

Each of these memory mapped registers provides a SEL field and a WMD bit. The SEL field is used to select the internal register. The WMD bit controls the write mode. If the WMD bit is set to 0 during the write access, all fields of the internal register are updated. If the WMD bit set to 1, only the SEL field is changed. All other fields of the internal register remain unchanged. This allows for reading back the values of the selected internal register in a subsequent read access.

22.5.2.3 Module Version Register (MVR)

Base + 0x0000

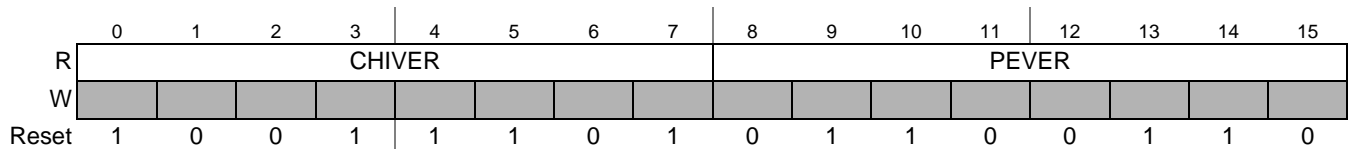

Figure 22-2. Module Version Register (MVR)

This register provides the controller version number. The module version number is derived from the CHI version number and the PE version number.

Table 22-7. MVR Field Descriptions

| Field | Description |
|--------|--|
| CHIVER | CHI Version Number — This field provides the version number of the controller host interface. |
| PEVER | PE Version Number — This field provides the version number of the protocol engine. |

22.5.2.4 Module Configuration Register (MCR)

Base + 0x0002

Write: MEN, SBFF, SCM, CHB, CHA, FUM, FAM, CLKSEL, BITRATE: Disabled Mode
SFFE: Disabled Mode or *POC:config*

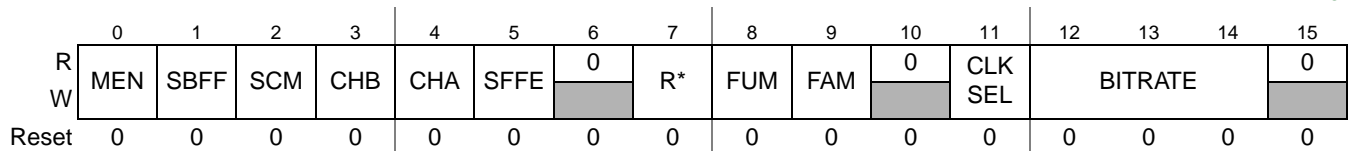

Figure 22-3. Module Configuration Register (MCR)

This register defines the global configuration of the controller.

Table 22-8. MCR Field Descriptions

| Field | Description |
|------------|--|
| MEN | <p>Module Enable — This bit indicates whether or not the controller is in the Disabled Mode. The application requests the controller to leave the Disabled Mode by writing 1 to this bit. Before leaving the Disabled Mode, the application must configure the SCM, SBFF, CHB, CHA, TMODE, BITRATE values. For details see Section 22.1.6, Modes of Operation.</p> <p>0 Write: ignored, controller disable not possible Read: controller disabled</p> <p>1 Write: enable controller Read: controller enabled</p> <p>Note: If the controller is enabled it can not be disabled.</p> |
| SBFF | <p>System Bus Failure Freeze — This bit controls the behavior of the controller in case of a system bus failure.</p> <p>0 Continue normal operation 1 Transition to freeze mode</p> |
| SCM | <p>Single Channel Device Mode — This control bit defines the channel device mode of the controller as described in Section 22.6.10, Channel Device Modes.</p> <p>0 controller works in dual channel device mode 1 controller works in single channel device mode</p> |
| CHB CHA | <p>Channel Enable — protocol related parameter: <i>pChannels</i></p> <p>The semantic of these control bits depends on the channel device mode controlled by the SCM bit and is given Table 22-9.</p> |
| SFFE | <p>Synchronization Frame Filter Enable — This bit controls the filtering for received synchronization frames. For details see Section 22.6.15, Sync Frame Filtering.</p> <p>0 Synchronization frame filtering disabled 1 Synchronization frame filtering enabled</p> |
| R* | <p>Reserved — This bit is reserved. It is read as 0. Application must not write 1 to this bit.</p> |
| FUM | <p>FIFO Update Mode — This bit controls the FIFO update behavior when the interrupt flags GIFER[FAFAIF] and DIFER[FAFBIF] are written by the application (see Section 22.6.9.8, FIFO Update).</p> <p>0 FIFOA (FIFOB) is updated on writing 1 to GIFER[FAFAIF] (GIFER[FAFBIF]) 1 FIFOA (FIFOB) is <i>not</i> updated on writing 1 to GIFER[FAFAIF] (GIFER[FAFBIF])</p> |
| FAM | <p>FIFO Address Mode — This bit controls the location of the system memory base address for the FIFOs. (see Section 22.6.9.2, FIFO Configuration).</p> <p>0 FIFO Base Address located in System Memory Base Address Register (SYMBADR) 1 FIFO Base Address located in Receive FIFO System Memory Base Address Register (RFSYMBADR)</p> |
| CLKSEL | <p>Protocol Engine Clock Source Select — This bit is used to select the clock source for the protocol engine.</p> <p>0 PE clock source is generated by on-chip crystal oscillator. 1 PE clock source is generated by on-chip PLL.</p> |
| BITRATE | <p>FlexRay Bus Bit Rate — This bit field defines the FlexRay Bus Bit Rate. 00010.0 Mbit/sec</p> <p>001 5.0 Mbit/sec 010 2.5 Mbit/sec 011 8.0 Mbit/sec 100 reserved 101 reserved 110 reserved 111 reserved</p> |

Table 22-9. FlexRay Channel Selection

| SCM | CHB | CHA | Description |
|-----------------------------------|-----|-----|--|
| Dual Channel Device Modes | | | |
| 0 | 0 | 0 | ports FR_A_RX, FR_A_TX, and $\overline{\text{FR_A_TX_EN}}$ not driven by controller ports FR_B_RX, FR_B_TX, and $\overline{\text{FR_A_TX_EN}}$ not driven by controller |
| | 0 | 1 | ports FR_A_RX, FR_A_TX, and $\overline{\text{FR_A_TX_EN}}$ driven by controller - connected to FlexRay channel A ports FR_B_RX, FR_B_TX, and $\overline{\text{FR_A_TX_EN}}$ not driven by controller |
| | 1 | 0 | ports FR_A_RX, FR_A_TX, and $\overline{\text{FR_A_TX_EN}}$ not driven by controller ports FR_B_RX, FR_B_TX, and $\overline{\text{FR_A_TX_EN}}$ driven by controller - connected to FlexRay channel B |
| | 1 | 1 | ports FR_A_RX, FR_A_TX, and $\overline{\text{FR_A_TX_EN}}$ driven by controller - connected to FlexRay channel A ports FR_B_RX, FR_B_TX, and $\overline{\text{FR_A_TX_EN}}$ driven by controller - connected to FlexRay channel B |
| Single Channel Device Mode | | | |
| 1 | 0 | 0 | ports FR_A_RX, FR_A_TX, and $\overline{\text{FR_A_TX_EN}}$ not driven by controller ports FR_B_RX, FR_B_TX, and $\overline{\text{FR_A_TX_EN}}$ not driven by controller |
| | 0 | 1 | ports FR_A_RX, FR_A_TX, and $\overline{\text{FR_A_TX_EN}}$ driven by controller - connected to FlexRay channel A ports FR_B_RX, FR_B_TX, and $\overline{\text{FR_A_TX_EN}}$ not driven by controller |
| | 1 | 0 | ports FR_A_RX, FR_A_TX, and $\overline{\text{FR_A_TX_EN}}$ driven by controller - connected to FlexRay channel B ports FR_B_RX, FR_B_TX, and $\overline{\text{FR_A_TX_EN}}$ not driven by controller |
| | 1 | 1 | reserved |

22.5.2.5 System Memory Base Address Register (SYMBADR)

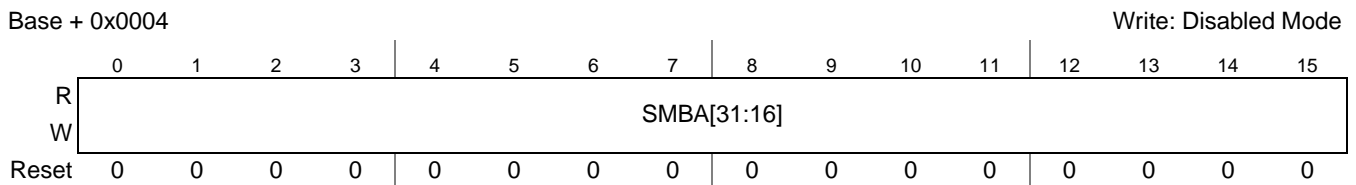
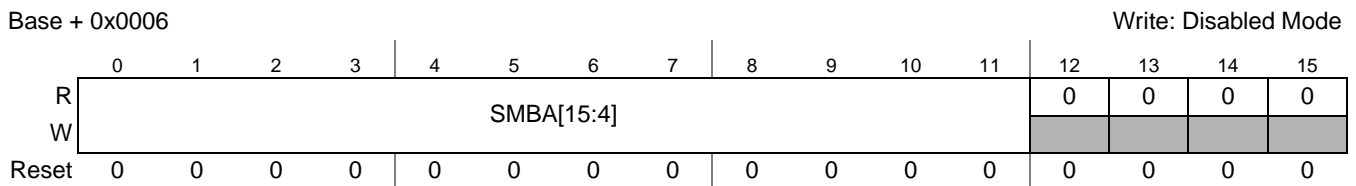
Figure 22-4. System Memory Base Address High Register (SYMBADHR)

Figure 22-5. System Memory Base Address Low Register (SYMBADLR)

NOTE

The system memory base address must be set before the controller is enabled.

The system memory base address registers define the base address of the flexray memory within the system memory. The base address is used by the BMIF to calculate the physical memory address for system memory accesses.

Table 22-10. SYMBADR Field Descriptions

| Field | Description |
|-------|--|
| SMBA | System Memory Base Address — This is the value of the system memory base address for the individual message buffers and sync frame table. This is the value of the system memory base address for the receive FIFO if the FIFO address mode bit MCR[FAM] is set to 1. It defines as a byte address. |

22.5.2.6 Strobe Signal Control Register (STBSCR)

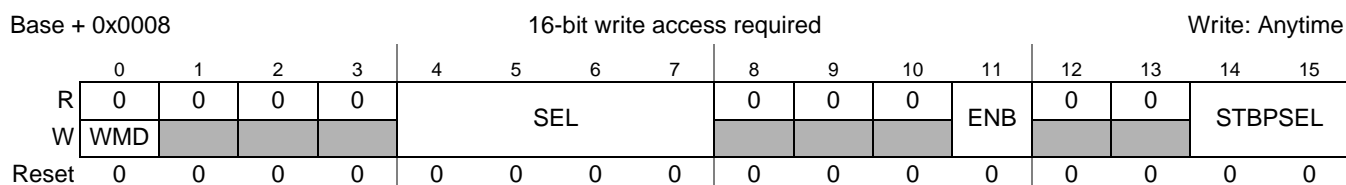
Figure 22-6. Strobe Signal Control Register (STBSCR)

This register is used to assign the individual protocol timing related strobe signals given in [Table 22-12](#) to the external strobe ports. Each strobe signal can be assigned to at most one strobe port. Each write access to registers overwrites the previously written ENB and STBPSEL values for the signal indicated by SEL. If more than one strobe signal is assigned to one strobe port, the current values of the strobe signals are combined with a binary OR and presented at the strobe port. If no strobe signal is assigned to a strobe port, the strobe port carries logic 0. For more detailed and timing information refer to [Section 22.6.16, Strobe Signal Support](#).

NOTE

In single channel device mode, channel B related strobe signals are undefined and should not be assigned to the strobe ports.

Table 22-11. STBSCR Field Descriptions

| Field | Description |
|---------|---|
| WMD | Write Mode — This control bit defines the write mode of this register. 0 Write to all fields in this register on write access. 1 Write to SEL field only on write access. |
| SEL | Strobe Signal Select — This control field selects one of the strobe signals given in Table 22-12 to be enabled or disabled and assigned to one of the four strobe ports given in Table 22-12 . |
| ENB | Strobe Signal Enable — The control bit is used to enable and to disable the strobe signal selected by STBPSEL. 0 Strobe signal is disabled and not assigned to any strobe port. 1 Strobe signal is enabled and assigned to the strobe port selected by STBPSEL. |
| STBPSEL | Strobe Port Select — This field selects the strobe port that the strobe signal selected by the SEL is assigned to. All strobe signals that are enabled and assigned to the same strobe port are combined with a binary OR operation. 00 assign selected signal to FR_DBG[0] 01 assign selected signal to FR_DBG[1] 10 assign selected signal to FR_DBG[2] 11 assign selected signal to FR_DBG[3] |

Table 22-12. Strobe Signal Mapping

| SEL | | Description | Channel | Type | Offset ¹ | Reference |
|-----|-----|---|---------|-------|---------------------|-----------|
| dec | hex | | | | | |
| 0 | 0x0 | arm | - | value | +1 | MT start |
| 1 | 0x1 | mt | - | value | +1 | MT start |
| 2 | 0x2 | cycle start | - | pulse | 0 | MT start |
| 3 | 0x3 | minislot start | - | pulse | 0 | MT start |
| 4 | 0x4 | slot start | A | pulse | 0 | MT start |
| 5 | 0x5 | | B | | | |
| 6 | 0x6 | receive data after glitch filtering | A | value | +4 | FR_A_RX |
| 7 | 0x7 | | B | | | FR_B_RX |
| 8 | 0x8 | channel idle indicator | A | level | +5 | FR_A_RX |
| 9 | 0x9 | | B | | | FR_B_RX |
| 10 | 0xA | syntax error detected | A | pulse | +4 | FR_A_RX |
| 11 | 0xB | | B | | | FR_B_RX |
| 12 | 0xC | content error detected | A | level | +4 | FR_A_RX |
| 13 | 0xD | | B | | | FR_B_RX |
| 14 | 0xE | receive FIFO almost-full interrupt flag | A | value | n.a. | FAFAIF |
| 15 | 0xF | | B | | | FAFBIF |

¹ Given in PE clock cycles

22.5.2.7 Message Buffer Data Size Register (MBDSR)

Base + 0x000C

Write: *POC:config*

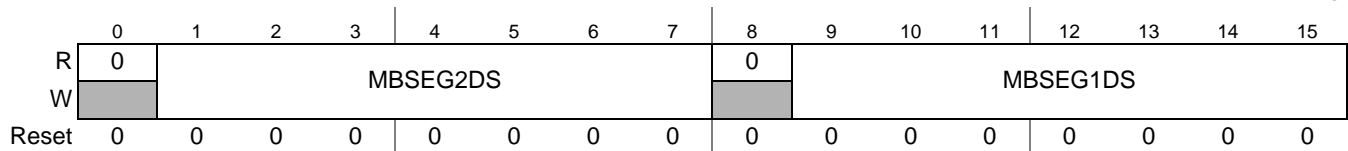

Figure 22-7. Message Buffer Data Size Register (MBDSR)

This register defines the size of the message buffer data section for the two message buffer segments in a number of two-byte entities.

The controller provides two independent segments for the individual message buffers. All individual message buffers within one segment have to have the same size for the message buffer data section. This size can be different for the two message buffer segments.

Table 22-13. MBDSR Field Descriptions

| Field | Description |
|----------|---|
| MBSEG2DS | Message Buffer Segment 2 Data Size — The field defines the size of the message buffer data section in two-byte entities for message buffers within the <i>second</i> message buffer segment. |
| MBSEG1DS | Message Buffer Segment 1 Data Size — The field defines the size of the message buffer data section in two-byte entities for message buffers within the <i>first</i> message buffer segment. |

22.5.2.8 Message Buffer Segment Size and Utilization Register (MBSSUTR)

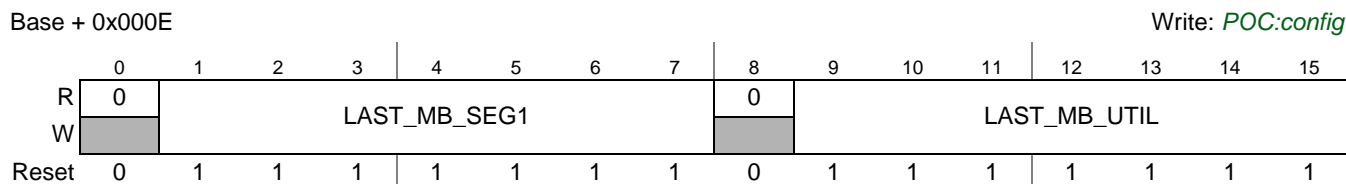

Figure 22-8. Message Buffer Segment Size and Utilization Register (MBSSUTR)

This register is used to define the last individual message buffer that belongs to the first message buffer segment and the number of the last used individual message buffer.

Table 22-14. MBSSUTR Field Descriptions

| Field | Description |
|--------------|---|
| LAST_MB_SEG1 | <p>Last Message Buffer In Segment 1 — This field defines the message buffer number of the last individual message buffer that is assigned to the <i>first</i> message buffer segment. The individual message buffers in the <i>first</i> segment correspond to the message buffer control registers MBCCSRn, MBCCFRn, MBFIDRn, MBIDXRn with $n \leq \text{LAST_MB_SEG1}$. The first message buffer segment contains $\text{LAST_MB_SEG1}+1$ individual message buffers.</p> <p>Note: The <i>first</i> message buffer segment contains <i>at least</i> one individual message buffer.</p> <p>The individual message buffers in the <i>second</i> message buffer segment correspond to the message buffer control registers MBCCSRn, MBCCFRn, MBFIDRn, MBIDXRn with $\text{LAST_MB_SEG1} < n < 128$.</p> <p>Note: If $\text{LAST_MB_SEG1} = 127$ all individual message buffers belong to the <i>first</i> message buffer segment and the <i>second</i> message buffer segment is empty.</p> |
| LAST_MB_UTIL | <p>Last Message Buffer Utilized — This field defines the message buffer number of last utilized individual message buffer. The message buffer search engine examines all individual message buffer with a message buffer number $n \leq \text{LAST_MB_UTIL}$.</p> <p>Note: If $\text{LAST_MB_UTIL} = \text{LAST_MB_SEG1}$ all individual message buffers belong to the <i>first</i> message buffer segment and the <i>second</i> message buffer segment is empty.</p> |

22.5.2.9 Protocol Operation Control Register (POCR)

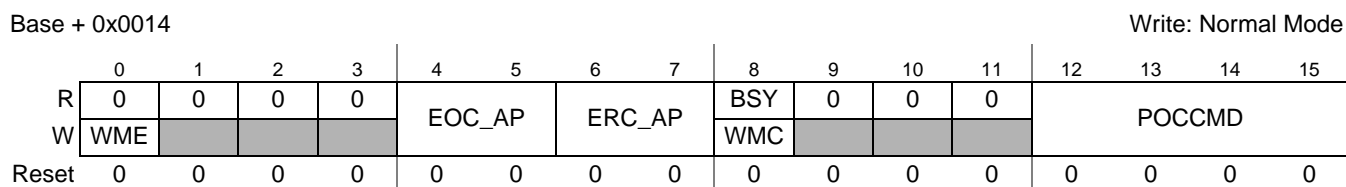

Figure 22-9. Protocol Operation Control Register (POCR)

The application uses this register to issue

- protocol control commands
- external clock correction commands

Protocol control commands are issued by writing to the POCCMD field. For more information on protocol control commands, see [Section 22.7.4, Protocol Control Command Execution](#).

External clock correction commands are issued by writing to the EOC_AP and ERC_AP fields. For more information on external clock correction, refer to [Section 22.6.11, External Clock Synchronization](#).

Table 22-15. POCR Field Descriptions

| Field | Description |
|--------|---|
| WME | Write Mode External Correction — This bit controls the write mode of the EOC_AP and ERC_AP fields. 0 Write to EOC_AP and ERC_AP fields on register write. 1 No write to EOC_AP and ERC_AP fields on register write. |
| EOC_AP | External Offset Correction Application — This field is used to trigger the application of the external offset correction value defined in the Protocol Configuration Register 29 (PCR29) . 00 do not apply external offset correction value 01 reserved 10 subtract external offset correction value 11 add external offset correction value |
| ERC_AP | External Rate Correction Application — This field is used to trigger application of the external rate correction value defined in the Protocol Configuration Register 21 (PCR21) 00 do not apply external rate correction value 01 reserved 10 subtract external rate correction value 11 add external rate correction value |
| BSY | Protocol Control Command Write Busy — This status bit indicates the acceptance of the protocol control command issued by the application via the POCCMD field. The controller sets this status bit when the application has issued a protocol control command via the POCCMD field. The controller clears this status bit when protocol control command was accepted by the PE. When the application issues a protocol control command while the BSY bit is asserted, the controller ignores this command, sets the protocol command ignored error flag PCMI_EF in the CHI Error Flag Register (CHIERFR) , and will not change the value of the POCCMD field. 0 Command write idle, command accepted and ready to receive new protocol command. 1 Command write busy, command not yet accepted, not ready to receive new protocol command. |
| WMC | Write Mode Command — This bit controls the write mode of the POCCMD field. 0 Write to POCCMD field on register write. 1 Do not write to POCCMD field on register write. |
| POCCMD | Protocol Control Command — The application writes to this field to issue a protocol control command to the PE. The controller sends the protocol command to the PE immediately. While the transfer is running, the BSY bit is set. 0000 ALLOW_COLDSTART — Immediately activate capability of node to cold start cluster. 0001 ALL_SLOTS — Delayed ¹ transition to the all slots transmission mode. 0010 CONFIG — Immediately transition to the <i>POC:config</i> state. 0011 FREEZE — Immediately transition to the <i>POC:halt</i> state. 0100 READY, CONFIG_COMPLETE — Immediately transition to the <i>POC:ready</i> state. 0101 RUN — Immediately transition to the <i>POC:startup start</i> state. 0110 DEFAULT_CONFIG — Immediately transition to the <i>POC:default config</i> state. 0111 HALT — Delayed transition to the <i>POC:halt</i> state 1000 WAKEUP — Immediately initiate the wakeup procedure. 1001 reserved 1010 reserved 1011 reserved 1100 reserved 1101 reserved 1110 reserved 1111 reserved |

¹ Delayed means on completion of current communication cycle.

22.5.2.10 Global Interrupt Flag and Enable Register (GIFER)

Base + 0x0016

Write: Normal Mode

| | | | | | | | | | | | | | | | | |
|-------|-----|------|------|--------|---------|---------|------|------|-----|------|------|-------|---------|---------|------|------|
| | 0 | 1 | 2 | 3 | 4 | 5 | 6 | 7 | 8 | 9 | 10 | 11 | 12 | 13 | 14 | 15 |
| R | MIF | PRIF | CHIF | WUP IF | FAFB IF | FAFA IF | RBIF | TBIF | MIE | PRIE | CHIE | WUPIE | FAFB IE | FAFA IE | RBIE | TBIE |
| W | | | | w1c | w1c | w1c | | | | | | | | | | |
| Reset | 0 | 0 | 0 | 0 | 0 | 0 | 0 | 0 | 0 | 0 | 0 | 0 | 0 | 0 | 0 | 0 |

Figure 22-10. Global Interrupt Flag and Enable Register (GIFER)

This register provides the means to control some of the interrupt request lines and provides the corresponding interrupt flags. The interrupt flags MIF, PRIF, CHIF, RBIF, and TBIF are the outcome of a binary OR of the related individual interrupt flags and interrupt enables. The generation scheme for these flags is depicted in Figure 22-150. For more details on interrupt generation, see Section 22.6.20, [Interrupt Support](#). These flags are cleared automatically when all of the corresponding interrupt flags or interrupt enables in the related interrupt flag and enable registers are cleared by the application.

Table 22-16. GIFER Field Descriptions

| Field | Description |
|--------|--|
| MIF | Module Interrupt Flag — This flag is set if at least one of the other interrupt flags in this register is asserted and the related interrupt enable is asserted, too. The controller generates the module interrupt request if MIE is asserted. 0 No interrupt flag is asserted or no interrupt enable is set 1 At least one of the other interrupt flags in this register is asserted and the related interrupt bit is asserted, too |
| PRIF | Protocol Interrupt Flag — This flag is set if at least one of the individual protocol interrupt flags in the Protocol Interrupt Flag Register 0 (PIFR0) and Protocol Interrupt Flag Register 1 (PIFR1) is asserted and the related interrupt enable flag is asserted, too. The controller generates the combined protocol interrupt request if the PRIE flag is asserted. 0 All individual protocol interrupt flags are equal to 0 or no interrupt enable bit is set. 1 At least one of the individual protocol interrupt flags and the related interrupt enable is equal to 1. |
| CHIF | CHI Interrupt Flag — This flag is set if at least one of the individual CHI error flags in the CHI Error Flag Register (CHIERFR) is asserted and the chi error interrupt enable GIFER[CHIE] is asserted. The controller generates the combined CHI error interrupt if the CHIE flag is asserted, too. 0 All CHI error flags are equal to 0 or the chi error interrupt is disabled 1 At least one CHI error flag is asserted and chi error interrupt is enabled |
| WUPIF | Wakeup Interrupt Flag — This flag is set when the controller has received a wakeup symbol on the FlexRay bus. The application can determine on which channel the wakeup symbol was received by reading the related wakeup flags WUB and WUA in the Protocol Status Register 3 (PSR3) . The controller generates the wakeup interrupt request if the WUPIE flag is asserted. 0 No wakeup condition or interrupt disabled 1 Wakeup symbol received on FlexRay bus and interrupt enabled |
| FAFBIF | Receive FIFO Channel B Almost Full Interrupt Flag — This flag is set when one of the following events occurs a) the current number of FIFO B entries is equal to or greater than the watermark defined by the WM field in the Receive FIFO Watermark and Selection Register (RFWMSR) , and the controller writes a received message into the FIFO B, or b) the current number of FIFO B entries is at least 1 and the periodic timer as defined by Receive FIFO Periodic Timer Register (RFPTR) expires. 0 no such event 1 FIFO B almost full event has occurred |

Table 22-16. GIFER Field Descriptions (continued)

| Field | Description |
|--------|---|
| FABAIF | <p>Receive FIFO Channel A Almost Full Interrupt Flag — This flag is set when one of the following events occurs</p> <p>a) the current number of FIFO A entries is equal to or greater than the watermark defined by the WM field in the Receive FIFO Watermark and Selection Register (RFWMSR), and the controller writes a received message into the FIFO A, or</p> <p>b) the current number of FIFO B entries is at least 1 and the periodic timer as defined by Receive FIFO Periodic Timer Register (RFPTR) expires.</p> <p>0 no such event 1 FIFO A almost full event has occurred</p> |
| RBIF | <p>Receive Message Buffer Interrupt Flag — This flag is set if for at least one of the individual receive message buffers (MBCCSn[MTD] = 0) both the interrupt flag MBIF and the interrupt enable bit MBIE in the corresponding Message Buffer Configuration, Control, Status Registers (MBCCSRn) are asserted. The application can not clear this RBIF flag directly. This flag is cleared by the controller when all of the interrupt flags MBIF of the individual receive message buffers are cleared by the application or if the application has cleared the interrupt enables bit MBIE.</p> <p>0 None of the individual receive message buffers has the MBIF and MBIE flag asserted. 1 At least one individual receive message buffer has the MBIF and MBIE flag asserted.</p> |
| TBIF | <p>Transmit Buffer Interrupt Flag — This flag is set if for at least one of the individual single or double transmit message buffers (MBCCSn[MTD] = 0) both the interrupt flag MBIF and the interrupt enable bit MBIE in the corresponding Message Buffer Configuration, Control, Status Registers (MBCCSRn) are equal to 1. The application can not clear this TBIF flag directly. This flag is cleared by the controller when either all of the individual interrupt flags MBIF of the individual transmit message buffers are cleared by the application or the host has cleared the interrupt enables bit MBIE.</p> <p>0 None of the individual transmit message buffers has the MBIF and MBIE flag asserted. 1 At least one individual transmit message buffer has the MBIF and MBIE flag asserted.</p> |
| MIE | <p>Module Interrupt Enable — This flag controls if the module interrupt line is asserted when the MIF flag is set.</p> <p>0 Disable interrupt line 1 Enable interrupt line</p> |
| PRIE | <p>Protocol Interrupt Enable — This flag controls if the protocol interrupt line is asserted when the PRIF flag is set.</p> <p>0 Disable interrupt line 1 Enable interrupt line</p> |
| CHIE | <p>CHI Interrupt Enable — This flag controls if the CHI interrupt line is asserted when the CHIF flag is set.</p> <p>0 Disable interrupt line 1 Enable interrupt line</p> |
| WUPIE | <p>Wakeup Interrupt Enable — This flag controls if the wakeup interrupt line is asserted when the WUPIF flag is set.</p> <p>0 Disable interrupt line 1 Enable interrupt line</p> |
| FAFBIE | <p>Receive FIFO Channel B Almost Full Interrupt Enable — This flag controls if the FIFO B interrupt line is asserted when the FAFBIF flag is set.</p> <p>0 Disable interrupt line 1 Enable interrupt line</p> |
| FABAIE | <p>Receive FIFO Channel A Almost Full Interrupt Enable — This flag controls if the FIFO A interrupt line is asserted when the FABAIF flag is set.</p> <p>0 Disable interrupt line 1 Enable interrupt line</p> |

Table 22-16. GIFER Field Descriptions (continued)

| Field | Description |
|-------|--|
| RBIE | Receive Buffer Interrupt Enable — This flag controls if the receive buffer interrupt line is asserted when the RBIF flag is set. 0 Disable interrupt line 1 Enable interrupt line |
| TBIE | Transmit Interrupt Enable — This flag controls if the transmit buffer interrupt line is asserted when the TBIF flag is set. 0 Disable interrupt line 1 Enable interrupt line |

22.5.2.11 Protocol Interrupt Flag Register 0 (PIFR0)

Base + 0x0018

Write: Normal Mode

| | 0 | 1 | 2 | 3 | 4 | 5 | 6 | 7 | 8 | 9 | 10 | 11 | 12 | 13 | 14 | 15 |
|-------|---------|---------|---------|--------|--------|--------|--------|--------|--------|---------|---------|---------|---------|--------|--------|--------|
| R | FATL_IF | INTL_IF | ILCF_IF | CSA_IF | MRC_IF | MOC_IF | CCL_IF | MXS_IF | MTX_IF | LTXB_IF | LTXA_IF | TBVB_IF | TBVA_IF | TI2_IF | TI1_IF | CYS_IF |
| W | w1c | w1c | w1c | w1c | w1c | w1c | w1c | w1c | w1c | w1c | w1c | w1c | w1c | w1c | w1c | w1c |
| Reset | 0 | 0 | 0 | 0 | 0 | 0 | 0 | 0 | 0 | 0 | 0 | 0 | 0 | 0 | 0 | 0 |

Figure 22-11. Protocol Interrupt Flag Register 0 (PIFR0)

The register holds one set of the protocol-related individual interrupt flags.

Table 22-17. PIFR0 Field Descriptions

| Field | Description |
|---------|--|
| FATL_IF | Fatal Protocol Error Interrupt Flag — This flag is set when the protocol engine has detected a fatal protocol error. In this case, the protocol engine goes into the <i>POC:halt</i> state immediately. The fatal protocol errors are: 1) <i>pLatestTx</i> violation, as described in the MAC process of the FlexRay protocol 2) transmission across slot boundary violation, as described in the FSP process of the FlexRay protocol 0 No such event. 1 Fatal protocol error detected. |
| INTL_IF | Internal Protocol Error Interrupt Flag — This flag is set when the protocol engine has detected an internal protocol error. In this case, the protocol engine goes into the <i>POC:halt</i> state immediately. An internal protocol error occurs when the protocol engine has not finished a calculation and a new calculation is requested. This can be caused by a hardware error. 0 No such event. 1 Internal protocol error detected. |
| ILCF_IF | Illegal Protocol Configuration Interrupt Flag — This flag is set when the protocol engine has detected an illegal protocol configuration parameter setting. In this case, the protocol engine goes into the <i>POC:halt</i> state immediately. The protocol engine checks the <i>listen_timeout</i> value programmed into the Protocol Configuration Register 14 (PCR14) and Protocol Configuration Register 15 (PCR15) when the CONFIG_COMPLETE command was sent by the application via the Protocol Operation Control Register (POCR) . If the value of <i>listen_timeout</i> is equal to zero, the protocol configuration setting is considered as illegal. 0 No such event. 1 Illegal protocol configuration detected. |

Table 22-17. PIFR0 Field Descriptions (continued)

| Field | Description |
|---------|--|
| CSA_IF | <p>Cold Start Abort Interrupt Flag — This flag is set when the configured number of allowed cold start attempts is reached and none of these attempts was successful. The number of allowed cold start attempts is configured by the <code>coldstart_attempts</code> field in the Protocol Configuration Register 3 (PCR3).</p> <p>0 No such event. 1 Cold start aborted and no more coldstart attempts allowed.</p> |
| MRC_IF | <p>Missing Rate Correction Interrupt Flag — This flag is set when an insufficient number of measurements is available for rate correction at the end of the communication cycle.</p> <p>0 No such event 1 Insufficient number of measurements for rate correction detected</p> |
| MOC_IF | <p>Missing Offset Correction Interrupt Flag — This flag is set when an insufficient number of measurements is available for offset correction. This is related to the <code>MISSING_TERM</code> event in the CSP process for offset correction in the FlexRay protocol.</p> <p>0 No such event. 1 Insufficient number of measurements for offset correction detected.</p> |
| CCL_IF | <p>Clock Correction Limit Reached Interrupt Flag — This flag is set when the internal calculated offset or rate calculation values have reached or exceeded its configured thresholds as given by the <code>offset_coorection_out</code> field in the Protocol Configuration Register 9 (PCR9) and the <code>rate_correction_out</code> field in the Protocol Configuration Register 14 (PCR14).</p> <p>0 No such event. 1 Offset or rate correction limit reached.</p> |
| MXS_IF | <p>Max Sync Frames Detected Interrupt Flag — This flag is set when the number of synchronization frames detected in the current communication cycle exceeds the value of the <code>node_sync_max</code> field in the Protocol Configuration Register 30 (PCR30).</p> <p>0 No such event. 1 More than <code>node_sync_max</code> sync frames detected.</p> <p>Note: Only synchronization frames that have passed the synchronization frame acceptance and rejection filters are taken into account.</p> |
| MTX_IF | <p>Media Access Test Symbol Received Interrupt Flag — This flag is set when the MTS symbol was received on channel A or channel B.</p> <p>0 No such event. 1 MTS symbol received.</p> |
| LTXB_IF | <p>pLatestTx Violation on Channel B Interrupt Flag — This flag is set when the frame transmission on channel B in the dynamic segment exceeds the dynamic segment boundary. This is related to the <i>pLatestTx</i> violation, as described in the MAC process of the FlexRay protocol.</p> <p>0 No such event. 1 <i>pLatestTx</i> violation occurred on channel B.</p> |
| LTXA_IF | <p>pLatestTx Violation on Channel A Interrupt Flag — This flag is set when the frame transmission on channel A in the dynamic segment exceeds the dynamic segment boundary. This is related to the <i>pLatestTx</i> violation as described in the MAC process of the FlexRay protocol.</p> <p>0 No such event. 1 <i>pLatestTx</i> violation occurred on channel A.</p> |
| TBVB_IF | <p>Transmission across boundary on channel B Interrupt Flag — This flag is set when the frame transmission on channel B crosses the slot boundary. This is related to the transmission across slot boundary violation as described in the FSP process of the FlexRay protocol.</p> <p>0 No such event. 1 Transmission across boundary violation occurred on channel B.</p> |

Table 22-17. PIFR0 Field Descriptions (continued)

| Field | Description |
|---------|---|
| TBVA_IF | Transmission across boundary on channel A Interrupt Flag — This flag is set when the frame transmission on channel A crosses the slot boundary. This is related to the transmission across slot boundary violation as described in the FSP process of the FlexRay protocol. 0 No such event. 1 Transmission across boundary violation occurred on channel A. |
| T12_IF | Timer 2 Expired Interrupt Flag — This flag is set whenever timer 2 expires. 0 No such event. 1 Timer 2 has reached its time limit. |
| T11_IF | Timer 1 Expired Interrupt Flag — This flag is set whenever timer 1 expires. 0 No such event 1 Timer 1 has reached its time limit |
| CYS_IF | Cycle Start Interrupt Flag — This flag is set when a communication cycle starts. 0 No such event 1 Communication cycle started. |

22.5.2.12 Protocol Interrupt Flag Register 1 (PIFR1)

Base + 0x001A

Write: Normal Mode

| | | | | | | | | | | | | | | | | |
|-------|--------|--------|---------|--------|---------|---------|---------|---------|---|---|--------|--------|----|----|----|----|
| | 0 | 1 | 2 | 3 | 4 | 5 | 6 | 7 | 8 | 9 | 10 | 11 | 12 | 13 | 14 | 15 |
| R | EMC_IF | IPC_IF | PECF_IF | PSC_IF | SSI3_IF | SSI2_IF | SSI1_IF | SSI0_IF | 0 | 0 | EVT_IF | ODT_IF | 0 | 0 | 0 | 0 |
| W | w1c | w1c | w1c | w1c | w1c | w1c | w1c | w1c | | | w1c | w1c | | | | |
| Reset | 0 | 0 | 0 | 0 | 0 | 0 | 0 | 0 | 0 | 0 | 0 | 0 | 0 | 0 | 0 | 0 |

Figure 22-12. Protocol Interrupt Flag Register 1 (PIFR1)

The register holds one set of the protocol-related individual interrupt flags.

Table 22-18. PIFR1 Field Descriptions

| Field | Description |
|---------|--|
| EMC_IF | Error Mode Changed Interrupt Flag — This flag is set when the value of the ERRMODE bit field in the Protocol Status Register 0 (PSR0) is changed by the controller. 0 No such event. 1 ERRMODE field changed. |
| IPC_IF | Illegal Protocol Control Command Interrupt Flag — This flag is set when the PE tries to execute a protocol control command, which was issued via the POCCMD field of the Protocol Operation Control Register (POCR) , and detects that this protocol control command is not allowed in the current protocol state. In this case the command is not executed. For more details, see Section 22.7.4, Protocol Control Command Execution . 0 No such event. 1 Illegal protocol control command detected. |
| PECF_IF | Protocol Engine Communication Failure Interrupt Flag — This flag is set if the controller has detected a communication failure between the protocol engine and the controller host interface 0 No such event. 1 Protocol Engine Communication Failure detected. |
| PSC_IF | Protocol State Changed Interrupt Flag — This flag is set when the protocol state in the PROTSTATE field in the Protocol Status Register 0 (PSR0) has changed. 0 No such event. 1 Protocol state changed. |

Table 22-18. PIFR1 Field Descriptions (continued)

| Field | Description |
|--|--|
| SSI3_IF SSI2_IF SSI1_IF SSI0_IF | Slot Status Counter Incremented Interrupt Flag — Each of these flags is set when the SLOTSTATUSCNT field in the corresponding Slot Status Counter Registers (SSCR0–SSCR3) is incremented. 0 No such event. 1 The corresponding slot status counter has incremented. |
| EVT_IF | Even Cycle Table Written Interrupt Flag — This flag is set if the controller has written the sync frame measurement / ID tables into the flexray memory for the even cycle. 0 No such event. 1 Sync frame measurement table written |
| ODT_IF | Odd Cycle Table Written Interrupt Flag — This flag is set if the controller has written the sync frame measurement / ID tables into the flexray memory for the odd cycle. 0 No such event. 1 Sync frame measurement table written |

22.5.2.13 Protocol Interrupt Enable Register 0 (PIER0)

Base + 0x001C

Write: Anytime

| | 0 | 1 | 2 | 3 | 4 | 5 | 6 | 7 | 8 | 9 | 10 | 11 | 12 | 13 | 14 | 15 |
|-------|------|------|------|-----|-----|-----|-----|-----|-----|------|------|------|------|-----|-----|-----|
| R | FATL | INTL | ILCF | CSA | MRC | MOC | CCL | MXS | MTX | LTXB | LTXA | TBVB | TBVA | TI2 | TI1 | CYS |
| W | _IE | _IE | _IE | _IE | _IE | _IE | _IE | _IE | _IE | _IE | _IE | _IE | _IE | _IE | _IE | _IE |
| Reset | 0 | 0 | 0 | 0 | 0 | 0 | 0 | 0 | 0 | 0 | 0 | 0 | 0 | 0 | 0 | 0 |

Figure 22-13. Protocol Interrupt Enable Register 0 (PIER0)

This register defines whether or not the individual interrupt flags defined in the [Protocol Interrupt Flag Register 0 \(PIFR0\)](#) can generate a protocol interrupt request.

Table 22-19. PIER0 Field Descriptions

| Field | Description |
|---------|---|
| FATL_IE | Fatal Protocol Error Interrupt Enable — This bit controls FATL_IF interrupt request generation. 0 interrupt request generation disabled 1 interrupt request generation enabled |
| INTL_IE | Internal Protocol Error Interrupt Enable — This bit controls INTL_IF interrupt request generation. 0 interrupt request generation disabled 1 interrupt request generation enabled |
| ILCF_IE | Illegal Protocol Configuration Interrupt Enable — This bit controls ILCF_IF interrupt request generation. 0 interrupt request generation disabled 1 interrupt request generation enabled |
| CSA_IE | Cold Start Abort Interrupt Enable — This bit controls CSA_IF interrupt request generation. 0 interrupt request generation disabled 1 interrupt request generation enabled |
| MRC_IE | Missing Rate Correction Interrupt Enable — This bit controls MRC_IF interrupt request generation. 0 interrupt request generation disabled 1 interrupt request generation enabled |
| MOC_IE | Missing Offset Correction Interrupt Enable — This bit controls MOC_IF interrupt request generation. 0 interrupt request generation disabled 1 interrupt request generation enabled |

Table 22-19. PIER0 Field Descriptions (continued)

| Field | Description |
|---------|--|
| CCL_IE | Clock Correction Limit Reached Interrupt Enable — This bit controls CCL_IF interrupt request generation. 0 interrupt request generation disabled 1 interrupt request generation enabled |
| MXS_IE | Max Sync Frames Detected Interrupt Enable — This bit controls MXS_IF interrupt request generation. 0 interrupt request generation disabled 1 interrupt request generation enabled |
| MTX_IE | Media Access Test Symbol Received Interrupt Enable — This bit controls MTX_IF interrupt request generation. 0 interrupt request generation disabled 1 interrupt request generation enabled |
| LTXB_IE | <i>pLatestTx</i> Violation on Channel B Interrupt Enable — This bit controls LTXB_IF interrupt request generation. 0 interrupt request generation disabled 1 interrupt request generation enabled |
| LTXA_IE | <i>pLatestTx</i> Violation on Channel A Interrupt Enable — This bit controls LTXA_IF interrupt request generation. 0 interrupt request generation disabled 1 interrupt request generation enabled |
| TBVB_IE | Transmission across boundary on channel B Interrupt Enable — This bit controls TBVB_IF interrupt request generation. 0 interrupt request generation disabled 1 interrupt request generation enabled |
| TBVA_IE | Transmission across boundary on channel A Interrupt Enable — This bit controls TBVA_IF interrupt request generation. 0 interrupt request generation disabled 1 interrupt request generation enabled |
| T12_IE | Timer 2 Expired Interrupt Enable — This bit controls T11_IF interrupt request generation. 0 interrupt request generation disabled 1 interrupt request generation enabled |
| T11_IE | Timer 1 Expired Interrupt Enable — This bit controls T11_IF interrupt request generation. 0 interrupt request generation disabled 1 interrupt request generation enabled |
| CYS_IE | Cycle Start Interrupt Enable — This bit controls CYC_IF interrupt request generation. 0 interrupt request generation disabled 1 interrupt request generation enabled |

22.5.2.14 Protocol Interrupt Enable Register 1 (PIER1)

Base + 0x001E

Write: Anytime

| | 0 | 1 | 2 | 3 | 4 | 5 | 6 | 7 | 8 | 9 | 10 | 11 | 12 | 13 | 14 | 15 |
|-------|-----|-----|------|-----|------|------|------|------|---|---|-----|-----|----|----|----|----|
| R | EMC | IPC | PECF | PSC | SSI3 | SSI2 | SSI1 | SSIO | 0 | 0 | EVT | ODT | 0 | 0 | 0 | 0 |
| W | _IE | _IE | _IE | _IE | _IE | _IE | _IE | _IE | | | _IE | _IE | | | | |
| Reset | 0 | 0 | 0 | 0 | 0 | 0 | 0 | 0 | 0 | 0 | 0 | 0 | 0 | 0 | 0 | 0 |

Figure 22-14. Protocol Interrupt Enable Register 1 (PIER1)

This register defines whether or not the individual interrupt flags defined in [Protocol Interrupt Flag Register 1 \(PIFR1\)](#) can generate a protocol interrupt request.

Table 22-20. PIER1 Field Descriptions

| Field | Description |
|--|--|
| EMC_IE | Error Mode Changed Interrupt Enable — This bit controls EMC_IF interrupt request generation. 0 interrupt request generation disabled 1 interrupt request generation enabled |
| IPC_IE | Illegal Protocol Control Command Interrupt Enable — This bit controls IPC_IF interrupt request generation. 0 interrupt request generation disabled 1 interrupt request generation enabled |
| PECF_IE | Protocol Engine Communication Failure Interrupt Enable — This bit controls PECF_IF interrupt request generation. 0 interrupt request generation disabled 1 interrupt request generation enabled |
| PSC_IE | Protocol State Changed Interrupt Enable — This bit controls PSC_IF interrupt request generation. 0 interrupt request generation disabled 1 interrupt request generation enabled |
| SSI3_IE SSI2_IE SSI1_IE SSI0_IE | Slot Status Counter Incremented Interrupt Enable — This bit controls SSI[3:0]_IF interrupt request generation. 0 interrupt request generation disabled 1 interrupt request generation enabled |
| EVT_IE | Even Cycle Table Written Interrupt Enable — This bit controls EVT_IF interrupt request generation. 0 interrupt request generation disabled 1 interrupt request generation enabled |
| ODT_IE | Odd Cycle Table Written Interrupt Enable — This bit controls ODT_IF interrupt request generation. 0 interrupt request generation disabled 1 interrupt request generation enabled |

22.5.2.15 CHI Error Flag Register (CHIERFR)

Base + 0x0020

Write: Normal Mode

| | 0 | 1 | 2 | 3 | 4 | 5 | 6 | 7 | 8 | 9 | 10 | 11 | 12 | 13 | 14 | 15 |
|-------|-------------|-------------|-------------|-------------|-------------|------------|------------|------------|------------|-------------|------------|------------|------------|------------|------------|-------------|
| R | FRLB _EF | FRLA _EF | PCMI _EF | FOVB _EF | FOVA _EF | MBS _EF | MBU _EF | LCK _EF | DBL _EF | SBCF _EF | FID _EF | DPL _EF | SPL _EF | NML _EF | NMF _EF | ILSA _EF |
| W | w1c | w1c | w1c | w1c | w1c | w1c | w1c | w1c | w1c | w1c | w1c | w1c | w1c | w1c | w1c | w1c |
| Reset | 0 | 0 | 0 | 0 | 0 | 0 | 0 | 0 | 0 | 0 | 0 | 0 | 0 | 0 | 0 | 0 |

Figure 22-15. CHI Error Flag Register (CHIERFR)

This register holds the CHI related error flags. The interrupt generation for each of these error flags is controlled by the CHI interrupt enable bit CHIE in the [Global Interrupt Flag and Enable Register \(GIFER\)](#).

Table 22-21. CHIERFR Field Descriptions

| Field | Description |
|---------|--|
| FRLB_EF | Frame Lost Channel B Error Flag — This flag is set if a complete frame was received on channel B but could not be stored in the selected individual message buffer because this message buffer is currently locked by the application. In this case, the frame and the related slot status information are lost. 0 No such event 1 Frame lost on channel B detected |
| FRLA_EF | Frame Lost Channel A Error Flag — This flag is set if a complete frame was received on channel A but could not be stored in the selected individual message buffer because this message buffer is currently locked by the application. In this case, the frame and the related slot status information are lost. 0 No such error 1 Frame lost on channel A detected |
| PCMI_EF | Protocol Command Ignored Error Flag — This flag is set if the application has issued a POC command by writing to the POCCMD field in the Protocol Operation Control Register (POCR) while the BSY flag is equal to 1. In this case the command is ignored by the controller and is lost. 0 No such error 1 POC command ignored |
| FOVB_EF | Receive FIFO Overrun Channel B Error Flag — This flag is set when an overrun of the FIFO for channel B occurred. This error occurs if a semantically valid frame was received on channel B and matches the all criteria to be appended to the FIFO for channel B but the FIFO is full. In this case, the received frame and its related slot status information is lost. 0 No such error 1 FIFO overrun on channel B has been detected |
| FOVA_EF | Receive FIFO Overrun Channel A Error Flag — This flag is set when an overrun of the FIFO for channel A occurred. This error occurs if a semantically valid frame was received on channel A and matches the all criteria to be appended to the FIFO for channel A but the FIFO is full. In this case, the received frame and its related slot status information is lost. 0 No such error 1 FIFO overrun on channel B has been detected |
| MSB_EF | Message Buffer Search Error Flag — This flag is set if the message buffer search engine is still running while the next search cycle must be started due to the FlexRay protocol timing. In this case, not all message buffers are considered while searching. 0 No such event 1 Search engine active while search start appears |
| MBU_EF | Message Buffer Utilization Error Flag — This flag is asserted if the application writes to a message buffer control field that is beyond the number of utilized message buffers programmed in the Message Buffer Segment Size and Utilization Register (MBSSUTR) . If the application writes to a MBCCSRn register with n > LAST_MB_UTIL, the controller ignores the write attempt and asserts the message buffer utilization error flag MBU_EF in the CHI Error Flag Register (CHIERFR) . 0 No such event 1 Non-utilized message buffer enabled |
| LCK_EF | Lock Error Flag — This flag is set if the application tries to lock a message buffer that is already locked by the controller due to internal operations. In that case, the controller does not grant the lock to the application. The application must issue the lock request again. 0 No such error 1 Lock error detected |
| DBL_EF | Double Transmit Message Buffer Lock Error Flag — This flag is set if the application tries to lock the transmit side of a double transmit message buffer. In this case, the controller does not grant the lock to the transmit side of a double transmit message buffer. 0 No such event 1 Double transmit buffer lock error occurred |

Table 22-21. CHIERFR Field Descriptions (continued)

| Field | Description |
|---------|--|
| SBCF_EF | System Bus Communication Failure Error Flag — This flag is set if a system bus access was not finished within the required amount of time (see Section 22.6.19.2, System Bus Access Timeout). 0 No such event 1 System bus access not finished in time |
| FID_EF | Frame ID Error Flag — This flag is set if the frame ID stored in the message buffer header area differs from the frame ID stored in the message buffer control register. 0 No such error occurred 1 Frame ID error occurred |
| DPL_EF | Dynamic Payload Length Error Flag — This flag is set if the payload length written into the message buffer header field of a single or double transmit message buffer assigned to the dynamic segment is greater than the maximum payload length for the dynamic segment as it is configured in the corresponding protocol configuration register field max_payload_length_dynamic in the Protocol Configuration Register 24 (PCR24) . 0 No such error occurred 1 Dynamic payload length error occurred |
| SPL_EF | Static Payload Length Error Flag — This flag is set if the payload length written into the message buffer header field of a single or double transmit message buffer assigned to the static segment is different from the payload length for the static segment as it is configured in the corresponding protocol configuration register field payload_length_static in the Protocol Configuration Register 19 (PCR19) . 0 No such error occurred 1 Static payload length error occurred |
| NML_EF | Network Management Length Error Flag — This flag is set if the payload length written into the header structure of a receive message buffer assigned to the static segment is less than the configured length of the Network Management Vector as configured in the Network Management Vector Length Register (NMVLR) . In this case the received part of the Network Management Vector will be used to update the Network Management Vector. 0 No such error occurred 1 Network management length error occurred |
| NMF_EF | Network Management Frame Error Flag — This flag is set if a received message in the static segment with a Preamble Indicator flag PP asserted has its Null Frame indicator flag NF asserted as well. In this case, the Global Network Management Registers (see Network Management Vector Registers (NMVR0–NMVR5)) are not updated. 0 No such error occurred 1 Network management frame error occurred |
| ILSA_EF | Illegal System Bus Address Error Flag — This flag is set if the external system bus subsystem has detected an access to an illegal system bus address from the controller (see Section 22.6.19.1, System Bus Illegal Address Access). 0 No such event 1 Illegal system bus address accessed |

22.5.2.16 Message Buffer Interrupt Vector Register (MBIVEC)

Base + 0x0022

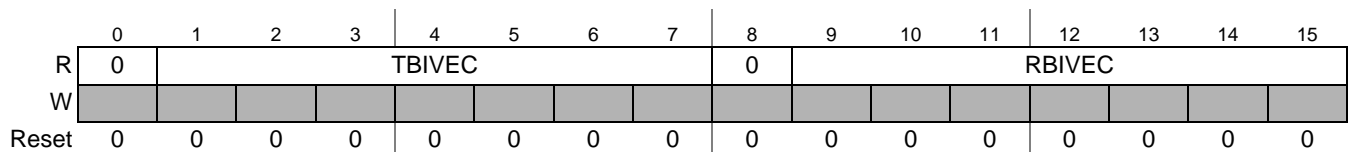
Figure 22-16. Message Buffer Interrupt Vector Register (MBIVEC)

This register provides the channel status error counter for channel B. The protocol engine generates a slot status vector for each static slot, each dynamic slot, the symbol window, and the NIT. The slot status vector contains the four protocol related error indicator bits *vSS!SyntaxError*, *vSS!ContentError*, *vSS!BViolation*, and *vSS!TxConflict*. The controller increments the status error counter by 1 if, for a slot or segment, at least one error indicator bit is set to 1. The counter wraps around after it has reached the maximum value. For more information on slot status monitoring see [Section 22.6.18, Slot Status Monitoring](#).

Table 22-24. CBSERCR Field Descriptions

| Field | Description |
|----------------|---|
| STATUS_ERR_CNT | Channel Status Error Counter — This field provides the current channel status error count. The counter value is updated within the first macrotick of the following slot or segment. |

22.5.2.19 Protocol Status Register 0 (PSR0)

Base + 0x0028

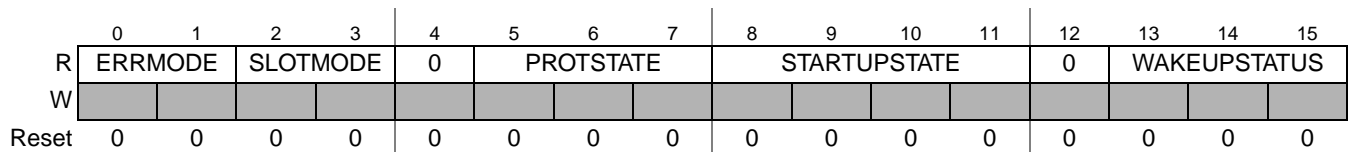
Figure 22-19. Protocol Status Register 0 (PSR0)

This register provides information about the current protocol status.

Table 22-25. PSR0 Field Descriptions

| Field | Description |
|-----------|---|
| ERRMODE | Error Mode — protocol related variable: <i>vPOC!ErrorMode</i> . This field indicates the error mode of the protocol. 00 ACTIVE 01 PASSIVE 10 COMM_HALT 11 reserved |
| SLOTMODE | Slot Mode — protocol related variable: <i>vPOC!SlotMode</i> . This field indicates the slot mode of the protocol. 00 SINGLE 01 ALL_PENDING 10 ALL 11 reserved |
| PROTSTATE | Protocol State — protocol related variable: <i>vPOC!State</i> . This field indicates the state of the protocol. 000 <i>POC:default config</i> 001 <i>POC:config</i> 010 <i>POC:wakeup</i> 011 <i>POC:ready</i> 100 <i>POC:normal passive</i> 101 <i>POC:normal active</i> 110 <i>POC:halt</i> 111 <i>POC:startup</i> |

Table 22-25. PSR0 Field Descriptions (continued)

| Field | Description |
|---------------|--|
| STARTUP STATE | <p>Startup State — protocol related variable: <i>vPOC!StartupState</i>. This field indicates the current sub-state of the startup procedure.</p> <p>0000 reserved 0001 reserved 0010 <i>POC:coldstart collision resolution</i> 0011 <i>POC:coldstart listen</i> 0100 <i>POC:integration consistency check</i> 0101 <i>POC:integrationi listen</i> 0110 reserved 0111 <i>POC:initialize schedule</i> 1000 reserved 1001 reserved 1010 <i>POC:coldstart consistency check</i> 1011 reserved 1100 reserved 1101 <i>POC:integration coldstart check</i> 1110 <i>POC:coldstart gap</i> 1111 <i>POC:coldstart join</i></p> |
| WAKEUP STATUS | <p>Wakeup Status — protocol related variable: <i>vPOC!WakeupStatus</i>. This field provides the outcome of the execution of the wakeup mechanism.</p> <p>000 UNDEFINED 001 RECEIVED_HEADER 010 RECEIVED_WUP 011 COLLISION_HEADER 100 COLLISION_WUP 101 COLLISION_UNKNOWN 110 TRANSMITTED 111 reserved</p> |

22.5.2.20 Protocol Status Register 1 (PSR1)

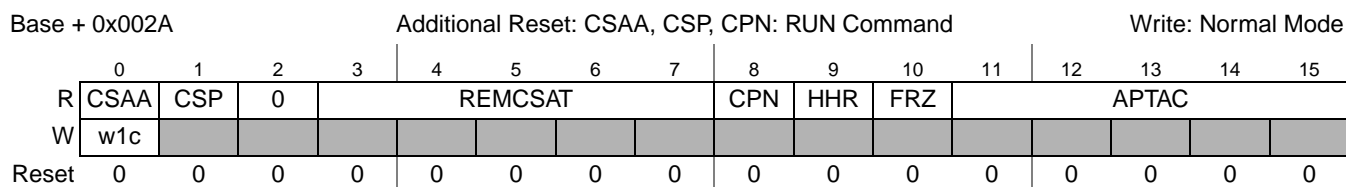

Figure 22-20. Protocol Status Register 1 (PSR1)

Table 22-26. PSR1 Field Descriptions

| Field | Description |
|-------|---|
| CSAA | <p>Cold Start Attempt Aborted Flag — protocol related event: 'set coldstart abort indicator in CHI' This flag is set when the controller has aborted a cold start attempt. 0 No such event 1 Cold start attempt aborted</p> |
| CSP | <p>Leading Cold Start Path — This status bit is set when the controller has reached the <i>POC:normal active</i> state via the leading cold start path. This indicates that this node has started the network 0 No such event 1 <i>POC:normal active</i> reached from <i>POC:startup</i> state via leading cold start path</p> |

Table 22-26. PSR1 Field Descriptions (continued)

| Field | Description |
|---------|--|
| REMCSAT | Remaining Coldstart Attempts — protocol related variable: <i>vRemainingColdstartAttempts</i> This field provides the number of remaining cold start attempts that the controller will execute. |
| CPN | Leading Cold Start Path Noise — protocol related variable: <i>vPOC!ColdstartNoise</i> This status bit is set if the controller has reached the <i>POC:normal active</i> state via the leading cold start path under noise conditions. This indicates there was some activity on the FlexRay bus while the controller was starting up the cluster. 0 No such event 1 <i>POC:normal active</i> state was reached from <i>POC:startup</i> state via noisy leading cold start path |
| HHR | Host Halt Request Pending — protocol related variable: <i>vPOC!CHIHaltRequest</i> This status bit is set when controller receives the HALT command from the application via the Protocol Operation Control Register (POCR) . The controller clears this status bit after a hard reset condition or when the protocol is in the <i>POC:default config</i> state. 0 No such event 1 HALT command received |
| FRZ | Freeze Occurred — protocol related variable: <i>vPOC!Freeze</i> This status bit is set when the controller has reached the <i>POC:halt</i> state due to the host FREEZE command or due to an internal error condition requiring immediate halt. The controller clears this status bit after a hard reset condition or when the protocol is in the <i>POC:default config</i> state. 0 No such event 1 Immediate halt due to FREEZE or internal error condition |
| APTAC | Allow Passive to Active Counter — protocol related variable: <i>vPOC!vAllowPassivetoActive</i> This field provides the number of consecutive even/odd communication cycle pairs that have passed with valid rate and offset correction terms, but the protocol is still in the <i>POC:normal passive</i> state due to an application configured delay to enter <i>POC:normal active</i> state. This delay is defined by the allow_passive_to_active field in the Protocol Configuration Register 12 (PCR12) . |

22.5.2.21 Protocol Status Register 2 (PSR2)

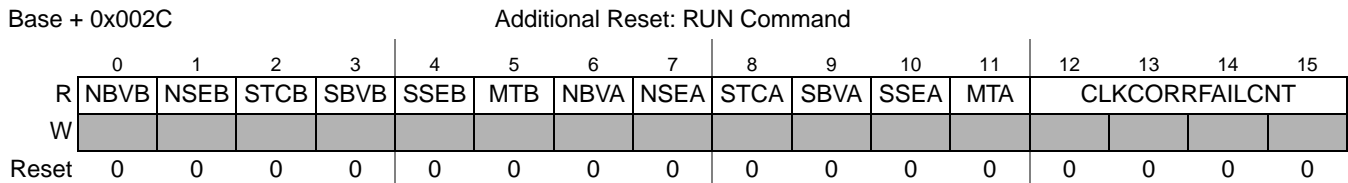
Figure 22-21. Protocol Status Register 2 (PSR2)

This register provides a snapshot of status information about the Network Idle Time NIT, the Symbol Window and the clock synchronization. The NIT related status bits NBVB, NSEB, NBVA, and NSEA are updated by the controller after the end of the NIT and before the end of the first slot of the next communication cycle. The Symbol Window related status bits STCB, SBVB, SSEB, MTB, STCA, SBVA, SSEB, and MTA are updated by the controller after the end of the symbol window and before the end of the current communication cycle. If no symbol window is configured, the symbol window related status bits remain in their reset state. The clock synchronization related CLKCORRFAILCNT is updated by the controller after the end of the static segment and before the end of the current communication cycle.

Table 22-27. PSR2 Field Descriptions

| Field | Description |
|-------|--|
| NBVB | NIT Boundary Violation on Channel B — protocol related variable: vSS!BViolation for NIT on channel B This status bit is set when there was some media activity on the FlexRay bus channel B at the end of the NIT. 0 No such event 1 Media activity at boundaries detected |
| NSEB | NIT Syntax Error on Channel B — protocol related variable: vSS!SyntaxError for NIT on channel B This status bit is set when a syntax error was detected during NIT on channel B. 0 No such event 1 Syntax error detected |
| STCB | Symbol Window Transmit Conflict on Channel B — protocol related variable: vSS!TxConflict for symbol window on channel B This status bit is set if there was a transmission conflict during the symbol window on channel B. 0 No such event 1 Transmission conflict detected |
| SBVB | Symbol Window Boundary Violation on Channel B — protocol related variable: vSS!BViolation for symbol window on channel B This status bit is set if there was some media activity on the FlexRay bus channel B at the start or at the end of the symbol window. 0 No such event 1 Media activity at boundaries detected |
| SSEB | Symbol Window Syntax Error on Channel B — protocol related variable: vSS!SyntaxError for symbol window on channel B This status bit is set when a syntax error was detected during the symbol window on channel B. 0 No such event 1 Syntax error detected |
| MTB | Media Access Test Symbol MTS Received on Channel B — protocol related variable: vSS!ValidMTS for Symbol Window on channel B This status bit is set if the Media Access Test Symbol MTS was received in the symbol window on channel B. 0 No such event 1 MTS symbol received |
| NBVA | NIT Boundary Violation on Channel A — protocol related variable: vSS!BViolation for NIT on channel A This status bit is set when there was some media activity on the FlexRay bus channel A at the end of the NIT. 0 No such event 1 Media activity at boundaries detected |
| NSEA | NIT Syntax Error on Channel A — protocol related variable: vSS!SyntaxError for NIT on channel A This status bit is set when a syntax error was detected during NIT on channel A. 0 No such event 1 Syntax error detected |
| STCA | Symbol Window Transmit Conflict on Channel A — protocol related variable: vSS!TxConflict for symbol window on channel A This status bit is set if there was a transmission conflicts during the symbol window on channel A. 0 No such event 1 Transmission conflict detected |
| SBVA | Symbol Window Boundary Violation on Channel A — protocol related variable: vSS!BViolation for symbol window on channel A This status bit is set if there was some media activity on the FlexRay bus channel A at the start or at the end of the symbol window. 0 No such event 1 Media activity at boundaries detected |

Table 22-27. PSR2 Field Descriptions (continued)

| Field | Description |
|-----------------|--|
| SSEA | Symbol Window Syntax Error on Channel A — protocol related variable: <i>vSSI!SyntaxError</i> for symbol window on channel A This status bit is set when a syntax error was detected during the symbol window on channel A. 0 No such event 1 Syntax error detected |
| MTA | Media Access Test Symbol MTS Received on Channel A — protocol related variable: <i>vSSI!ValidMTS</i> for symbol window on channel A This status bit is set if the Media Access Test Symbol MTS was received in the symbol window on channel A. 1 MTS symbol received 0 No such event |
| CLKCORR-FAILCNT | Clock Correction Failed Counter — protocol related variable: <i>vClockCorrectionFailed</i> This field provides the number of consecutive even/odd communication cycle pairs that have passed without clock synchronization having performed an offset or a rate correction due to lack of synchronization frames. It is not incremented when it has reached the configured value of either <i>max_without_clock_correction_fatal</i> or <i>max_without_clock_correction_passive</i> as defined in the Protocol Configuration Register 8 (PCR8) . The controller resets this counter on a hard reset condition, when the protocol enters the <i>POC:normal active</i> state, or when both the rate and offset correction terms have been calculated successfully. |

22.5.2.22 Protocol Status Register 3 (PSR3)

| Base + 0x002E | | | | Additional Reset: RUN Command | | | | Write: Normal Mode | | | | | | | | |
|---------------|---|---|-----|-------------------------------|------|------|------|--------------------|---|---|-----|------|------|------|------|------|
| | 0 | 1 | 2 | 3 | 4 | 5 | 6 | 7 | 8 | 9 | 10 | 11 | 12 | 13 | 14 | 15 |
| R | 0 | 0 | WUB | ABVB | AACB | ACEB | ASEB | AVFB | 0 | 0 | WUA | ABVA | AACA | ACEA | ASEA | AVFA |
| W | | | w1c | w1c | w1c | w1c | w1c | w1c | | | w1c | w1c | w1c | w1c | w1c | w1c |
| Reset | 0 | 0 | 0 | 0 | 0 | 0 | 0 | 0 | 0 | 0 | 0 | 0 | 0 | 0 | 0 | 0 |

Figure 22-22. Protocol Status Register 3 (PSR3)

This register provides aggregated channel status information as an accrued status of channel activity for all communication slots, regardless of whether they are assigned for transmission or subscribed for reception. It provides accrued information for the symbol window, the NIT, and the wakeup status.

Table 22-28. PSR3 Field Descriptions

| Field | Description |
|-------|--|
| WUB | Wakeup Symbol Received on Channel B — This flag is set when a wakeup symbol was received on channel B. 0 No wakeup symbol received 1 Wakeup symbol received |
| ABVB | Aggregated Boundary Violation on Channel B — This flag is set when a boundary violation has been detected on channel B. Boundary violations are detected in the communication slots, the symbol window, and the NIT. 0 No boundary violation detected 1 Boundary violation detected |
| AACB | Aggregated Additional Communication on Channel B — This flag is set when at least one valid frame was received on channel B in a slot that also contained an additional communication with either syntax error, content error, or boundary violations. 0 No additional communication detected 1 Additional communication detected |

Table 22-28. PSR3 Field Descriptions (continued)

| Field | Description |
|-------|---|
| ACEB | Aggregated Content Error on Channel B — This flag is set when a content error has been detected on channel B. Content errors are detected in the communication slots, the symbol window, and the NIT. 0 No content error detected 1 Content error detected |
| ASEB | Aggregated Syntax Error on Channel B — This flag is set when a syntax error has been detected on channel B. Syntax errors are detected in the communication slots, the symbol window and the NIT. 0 No syntax error detected 1 Syntax errors detected |
| AVFB | Aggregated Valid Frame on Channel B — This flag is set when a syntactically correct valid frame has been received in any static or dynamic slot through channel B. 1 At least one syntactically valid frame received 0 No syntactically valid frames received |
| WUA | Wakeup Symbol Received on Channel A — This flag is set when a wakeup symbol was received on channel A. 0 No wakeup symbol received 1 Wakeup symbol received |
| ABVA | Aggregated Boundary Violation on Channel A — This flag is set when a boundary violation has been detected on channel A. Boundary violations are detected in the communication slots, the symbol window, and the NIT. 0 No boundary violation detected 1 Boundary violation detected |
| AACA | Aggregated Additional Communication on Channel A — This flag is set when a valid frame was received in a slot on channel A that also contained an additional communication with either syntax error, content error, or boundary violations. 0 No additional communication detected 1 Additional communication detected |
| ACEA | Aggregated Content Error on Channel A — This flag is set when a content error has been detected on channel A. Content errors are detected in the communication slots, the symbol window, and the NIT. 0 No content error detected 1 Content error detected |
| ASEA | Aggregated Syntax Error on Channel A — This flag is set when a syntax error has been detected on channel A. Syntax errors are detected in the communication slots, the symbol window, and the NIT. 0 No syntax error detected 1 Syntax errors detected |
| AVFA | Aggregated Valid Frame on Channel A — This flag is set when a syntactically correct valid frame has been received in any static or dynamic slot through channel A. 0 No syntactically valid frames received 1 At least one syntactically valid frame received |

22.5.2.23 Macrotick Counter Register (MTCTR)

Base + 0x0030

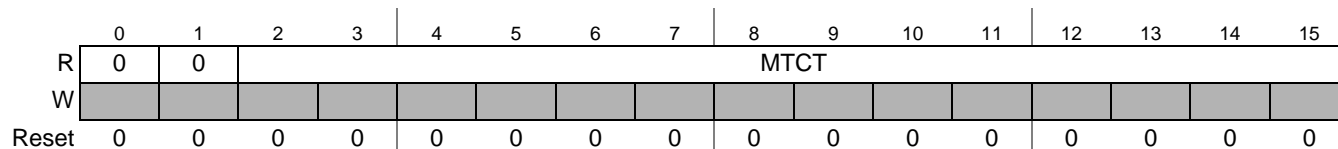

Figure 22-23. Macrotick Counter Register (MTCTR)

This register provides the macrotick count of the current communication cycle.

Table 22-29. MTCTR Field Descriptions

| Field | Description |
|-------|---|
| MTCT | Macrotick Counter — protocol related variable: vMacroTick This field provides the macrotick count of the current communication cycle. |

22.5.2.24 Cycle Counter Register (CYCTR)

Base + 0x0032

| | 0 | 1 | 2 | 3 | 4 | 5 | 6 | 7 | 8 | 9 | 10 | 11 | 12 | 13 | 14 | 15 |
|-------|----------|---|---|---|---|---|---|---|---|---|--------|----|----|----|----|----|
| R | 0 | 0 | 0 | 0 | 0 | 0 | 0 | 0 | 0 | 0 | CYCCNT | | | | | |
| W | [Shaded] | | | | | | | | | | | | | | | |
| Reset | 0 | 0 | 0 | 0 | 0 | 0 | 0 | 0 | 0 | 0 | 0 | 0 | 0 | 0 | 0 | 0 |

Figure 22-24. Cycle Counter Register (CYCTR)

This register provides the number of the current communication cycle.

Table 22-30. CYCTR Field Descriptions

| Field | Description |
|--------|---|
| CYCCNT | Cycle Counter — protocol related variable: vCycleCounter This field provides the number of the current communication cycle. If the counter reaches the maximum value of 63, the counter wraps and starts from zero again. |

22.5.2.25 Slot Counter Channel A Register (SLTCTAR)

Base + 0x0034

| | 0 | 1 | 2 | 3 | 4 | 5 | 6 | 7 | 8 | 9 | 10 | 11 | 12 | 13 | 14 | 15 |
|-------|----------|---|---|---|---|----------|---|---|---|---|----|----|----|----|----|----|
| R | 0 | 0 | 0 | 0 | 0 | SLOTCNTA | | | | | | | | | | |
| W | [Shaded] | | | | | | | | | | | | | | | |
| Reset | 0 | 0 | 0 | 0 | 0 | 0 | 0 | 0 | 0 | 0 | 0 | 0 | 0 | 0 | 0 | 0 |

Figure 22-25. Slot Counter Channel A Register (SLTCTAR)

This register provides the number of the current slot in the current communication cycle for channel A.

Table 22-31. SLTCTAR Field Descriptions

| Field | Description |
|----------|---|
| SLOTCNTA | Slot Counter Value for Channel A — protocol related variable: vSlotCounter for channel A This field provides the number of the current slot in the current communication cycle. |

22.5.2.26 Slot Counter Channel B Register (SLTCTBR)

Base + 0x0036

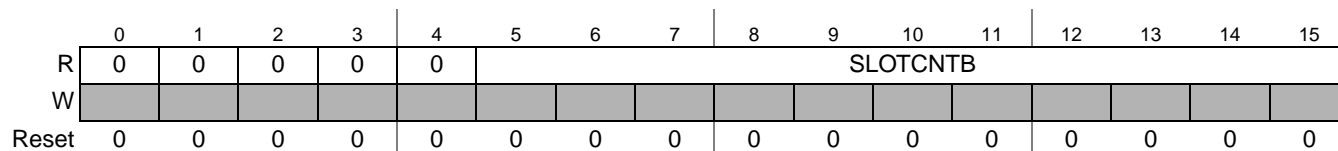

Figure 22-26. Slot Counter Channel B Register (SLTCTBR)

This register provides the number of the current slot in the current communication cycle for channel B.

Table 22-32. SLTCTBR Field Descriptions

| Field | Description |
|----------|--|
| SLOTCNTA | Slot Counter Value for Channel B — protocol related variable: <i>vSlotCounter</i> for channel B This field provides the number of the current slot in the current communication cycle. |

22.5.2.27 Rate Correction Value Register (RTCORVR)

Base + 0x0038

Additional Reset: RUN Command

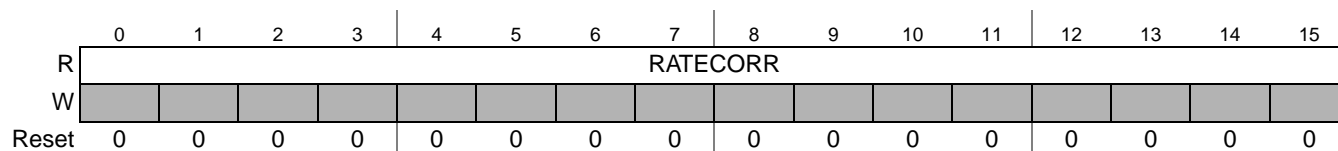

Figure 22-27. Rate Correction Value Register (RTCORVR)

This register provides the sign extended rate correction value in microticks as it was calculated by the clock synchronization algorithm. The controller updates this register during the NIT of each odd numbered communication cycle.

Table 22-33. RTCORVR Field Descriptions

| Field | Description |
|----------|--|
| RATECORR | Rate Correction Value — protocol related variable: <i>vRateCorrection</i> (before value limitation and external rate correction) This field provides the sign extended rate correction value in microticks as it was calculated by the clock synchronization algorithm. The value is represented in 2's complement format. This value does not include the value limitation and the application of the external rate correction. If the magnitude of the internally calculated rate correction value exceeds the limit given by <code>rate_correction_out</code> in the Protocol Configuration Register 13 (PCR13) , the clock correction reached limit interrupt flag <code>CCL_IF</code> is set in the Protocol Interrupt Flag Register 0 (PIFR0) . Note: If the controller was not able to calculate a new rate correction term due to a lack of synchronization frames, the RATECORR value is not updated. |

22.5.2.28 Offset Correction Value Register (OFCORVR)

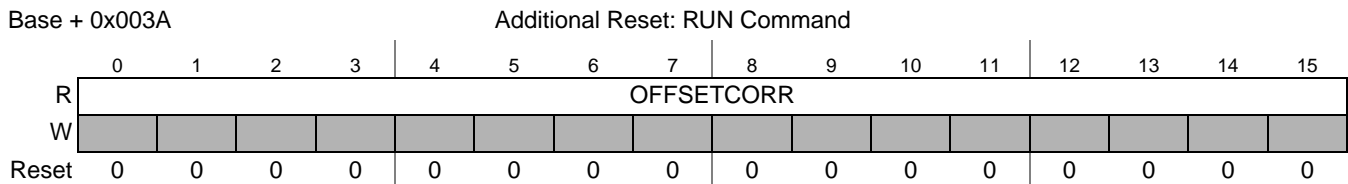

Figure 22-28. Offset Correction Value Register (OFCORVR)

This register provides the sign extended offset correction value in microticks as it was calculated by the clock synchronization algorithm. The controller updates this register during the NIT.

Table 22-34. OFCORVR Field Descriptions

| Field | Description |
|-------------|--|
| OFFSET-CORR | <p>Offset Correction Value — protocol related variable: <i>vOffsetCorrection</i> (before value limitation and external offset correction)</p> <p>This field provides the sign extended offset correction value in microticks as it was calculated by the clock synchronization algorithm. The value is represented in 2's complement format. This value does not include the value limitation and the application of the external offset correction. If the magnitude of the internally calculated rate correction value exceeds the limit given by <code>offset_correction_out</code> field in the Protocol Configuration Register 29 (PCR29), the clock correction reached limit interrupt flag <code>CCL_IF</code> is set in the Protocol Interrupt Flag Register 0 (PIFR0).</p> <p>Note: If the controller was not able to calculate an new offset correction term due to a lack of synchronization frames, the OFFSETCORR value is not updated.</p> |

22.5.2.29 Combined Interrupt Flag Register (CIFRR)

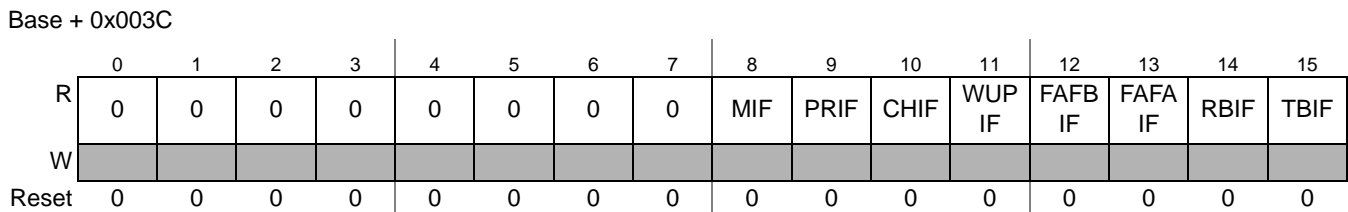

Figure 22-29. Combined Interrupt Flag Register (CIFRR)

This register provides five combined interrupt flags and a copy of three individual interrupt flags. The combined interrupt flags are the result of a binary OR of the values of other interrupt flags regardless of the state of the interrupt enable bits. The generation scheme for the combined interrupt flags is depicted in [Figure 22-152](#). The individual interrupt flags `WUPIF`, `FAFBIF`, and `FAFAIF` are copies of corresponding flags in the [Global Interrupt Flag and Enable Register \(GIFER\)](#) and are provided here to simplify the application interrupt flag check. To clear the individual interrupt flags, the application must use the [Global Interrupt Flag and Enable Register \(GIFER\)](#).

NOTE

The meanings of the combined status bits `MIF`, `PRIF`, `CHIF`, `RBIF`, and `TBIF` are different from those mentioned in the [Global Interrupt Flag and Enable Register \(GIFER\)](#).

Table 22-35. CIFRR Field Descriptions

| Field | Description |
|--------|--|
| MIF | Module Interrupt Flag — This flag is set if there is at least one interrupt source that has its interrupt flag asserted. 0 No interrupt source has its interrupt flag asserted 1 At least one interrupt source has its interrupt flag asserted |
| PRIF | Protocol Interrupt Flag — This flag is set if at least one of the individual protocol interrupt flags in the Protocol Interrupt Flag Register 0 (PIFR0) or Protocol Interrupt Flag Register 1 (PIFR1) is equal to 1. 0 All individual protocol interrupt flags are equal to 0 1 At least one of the individual protocol interrupt flags is equal to 1 |
| CHIF | CHI Interrupt Flag — This flag is set if at least one of the individual CHI error flags in the CHI Error Flag Register (CHIERFR) is equal to 1. 0 All CHI error flags are equal to 0 1 At least one CHI error flag is equal to 1 |
| WUPIF | Wakeup Interrupt Flag — Provides the same value as GIFER[WUPIF] |
| FAFBIF | Receive FIFO Channel B Almost Full Interrupt Flag — Provides the same value as GIFER[FAFBIF] |
| FAFAIF | Receive FIFO Channel A Almost Full Interrupt Flag — Provides the same value as GIFER[FAFAIF] |
| RBIF | Receive Message Buffer Interrupt Flag — This flag is set if for at least one of the individual receive message buffers (MBCCSRn[MTD] = 0) the interrupt flag MBIF in the corresponding Message Buffer Configuration, Control, Status Registers (MBCCSRn) is equal to 1. 0 None of the individual receive message buffers has the MBIF flag asserted. 1 At least one individual receive message buffers has the MBIF flag asserted. |
| TBIF | Transmit Message Buffer Interrupt Flag — This flag is set if for at least one of the individual single or double transmit message buffers (MBCCSRn[MTD] = 1) the interrupt flag MBIF in the corresponding Message Buffer Configuration, Control, Status Registers (MBCCSRn) is equal to 1. 0 None of the individual transmit message buffers has the MBIF flag asserted. 1 At least one individual transmit message buffers has the MBIF flag asserted. |

22.5.2.30 System Memory Access Time-Out Register (SYMATOR)

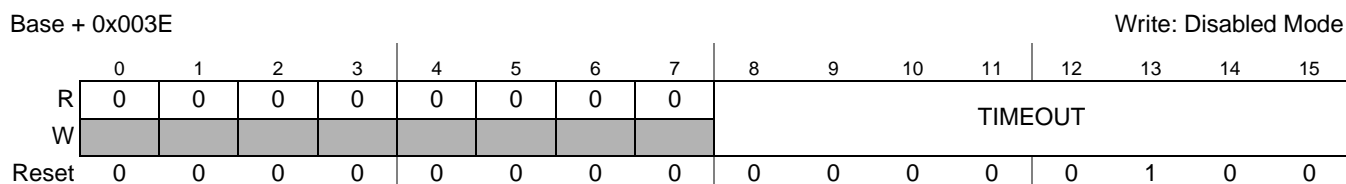

Figure 22-30. System Memory Access Time-Out Register (SYMATOR)

Table 22-36. SYMATOR Field Descriptions

| Field | Description |
|---------|---|
| TIMEOUT | System Memory Access Time-Out — This value defines the maximum amount of time to finish a system bus access in order to ensure correct frame transmission and reception (see Section 22.6.19.2, System Bus Access Timeout). |

22.5.2.31 Sync Frame Counter Register (SFCNTR)

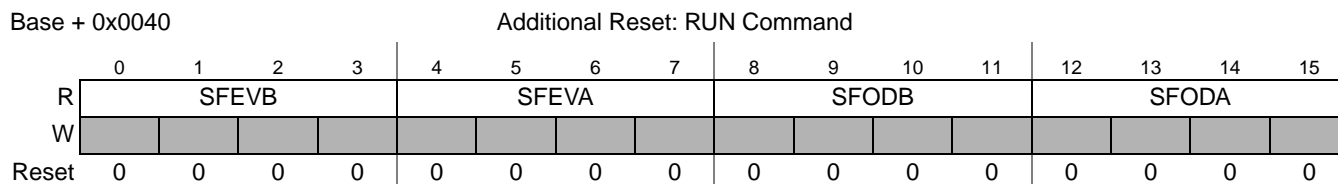

Figure 22-31. Sync Frame Counter Register (SFCNTR)

This register provides the number of synchronization frames that are used for clock synchronization in the last even and in the last odd numbered communication cycle. This register is updated after the start of the NIT and before 10 MT after offset correction start.

NOTE

If the application has locked the even synchronization table at the end of the static segment of an even communication cycle, the controller will not update the fields SFEVB and SFEVA.

If the application has locked the odd synchronization table at the end of the static segment of an odd communication cycle, the controller will not update the values SFODB and SFODA.

Table 22-37. SFCNTR Field Descriptions

| Field | Description |
|-------|---|
| SFEVB | Sync Frames Channel B, even cycle — protocol related variable: size of (<i>vsSynclListB</i> for even cycle) This field provides the size of the internal list of frame IDs of received synchronization frames used for clock synchronization. |
| SFEVA | Sync Frames Channel A, even cycle — protocol related variable: size of (<i>vsSynclListA</i> for even cycle) This field provides the size of the internal list of frame IDs of received synchronization frames used for clock synchronization. |
| SFODB | Sync Frames Channel B, odd cycle — protocol related variable: size of (<i>vsSynclListB</i> for odd cycle) This field provides the size of the internal list of frame IDs of received synchronization frames used for clock synchronization. |
| SFODA | Sync Frames Channel A, odd cycle — protocol related variable: size of (<i>vsSynclListA</i> for odd cycle) This field provides the size of the internal list of frame IDs of received synchronization frames used for clock synchronization. |

22.5.2.32 Sync Frame Table Offset Register (SFTOR)

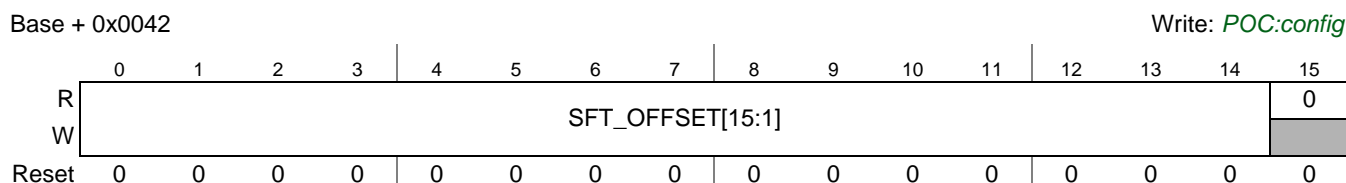

Figure 22-32. Sync Frame Table Offset Register (SFTOR)

This register defines the Flexray Memory related offset for sync frame tables. For more details, see [Section 22.6.12, Sync Frame ID and Sync Frame Deviation Tables](#).

Table 22-38. SFTOR Field Description

| Field | Description |
|-------|---|
| SFTOR | Sync Frame Table Offset — The offset of the Sync Frame Tables in the Flexray Memory. This offset is required to be 16-bit aligned. Thus STF_OFFSET[0] is always 0. |

22.5.2.33 Sync Frame Table Configuration, Control, Status Register (SFTCCSR)

Base + 0x0044

Write: Normal Mode

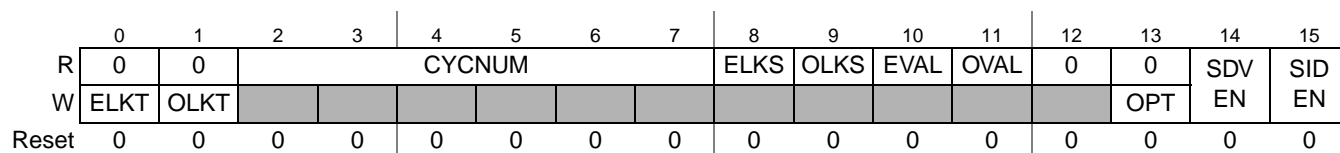

Figure 22-33. Sync Frame Table Configuration, Control, Status Register (SFTCCSR)

This register provides configuration, control, and status information related to the generation and access of the clock sync ID tables and clock sync measurement tables. For a detailed description, see [Section 22.6.12, Sync Frame ID and Sync Frame Deviation Tables](#).

Table 22-39. SFTCCSR Field Descriptions

| Field | Description |
|--------|---|
| ELKT | Even Cycle Tables Lock/Unlock Trigger — This trigger bit is used to lock and unlock the even cycle tables. 0 No effect 1 Triggers lock/unlock of the even cycle tables. |
| OLKT | Odd Cycle Tables Lock/Unlock Trigger — This trigger bit is used to lock and unlock the odd cycle tables. 0 No effect 1 Triggers lock/unlock of the odd cycle tables. |
| CYCNUM | Cycle Number — This field provides the number of the cycle in which the currently locked table was recorded. If none or both tables are locked, this value is related to the even cycle table. |
| ELKS | Even Cycle Tables Lock Status — This status bit indicates whether the application has locked the even cycle tables. 0 Application has not locked the even cycle tables. 1 Application has locked the even cycle tables. |
| OLKS | Odd Cycle Tables Lock Status — This status bit indicates whether the application has locked the odd cycle tables. 0 Application has not locked the odd cycle tables. 1 Application has locked the odd cycle tables. |
| EVAL | Even Cycle Tables Valid — This status bit indicates whether the Sync Frame ID and Sync Frame Deviation Tables for the even cycle are valid. The controller clears this status bit when it starts updating the tables, and sets this bit when it has finished the table update. 0 Tables are not valid (update is ongoing) 1 Tables are valid (consistent). |
| OVAL | Odd Cycle Tables Valid — This status bit indicates whether the Sync Frame ID and Sync Frame Deviation Tables for the odd cycle are valid. The controller clears this status bit when it starts updating the tables, and sets this bit when it has finished the table update. 0 Tables are not valid (update is ongoing) 1 Tables are valid (consistent). |

Table 22-39. SFTCCSR Field Descriptions (continued)

| Field | Description |
|-------|--|
| OPT | <p>One Pair Trigger — This trigger bit controls whether the controller writes continuously or only one pair of Sync Frame Tables into the flexray memory.</p> <p>If this trigger is set to 1 while SDVEN or SIDEN is set to 1, the controller writes only one pair of the enabled Sync Frame Tables corresponding to the next even-odd-cycle pair into the flexray memory. In this case, the controller clears the SDVEN or SIDEN bits immediately.</p> <p>If this trigger is set to 0 while SDVEN or SIDEN is set to 1, the controller writes continuously the enabled Sync Frame Tables into the flexray memory.</p> <p>0 Write continuously pairs of enabled Sync Frame Tables into flexray memory. 1 Write only one pair of enabled Sync Frame Tables into flexray memory.</p> |
| SDVEN | <p>Sync Frame Deviation Table Enable — This bit controls the generation of the Sync Frame Deviation Tables. The application must set this bit to request the controller to write the Sync Frame Deviation Tables into the flexray memory.</p> <p>0 Do not write Sync Frame Deviation Tables 1 Write Sync Frame Deviation Tables into flexray memory</p> <p>Note: If SDVEN is set to 1, then SIDEN must also be set to 1.</p> |
| SIDEN | <p>Sync Frame ID Table Enable — This bit controls the generation of the Sync Frame ID Tables. The application must set this bit to 1 to request the controller to write the Sync Frame ID Tables into the flexray memory.</p> <p>0 Do not write Sync Frame ID Tables 1 Write Sync Frame ID Tables into flexray memory</p> |

22.5.2.34 Sync Frame ID Rejection Filter Register (SFIDRFR)

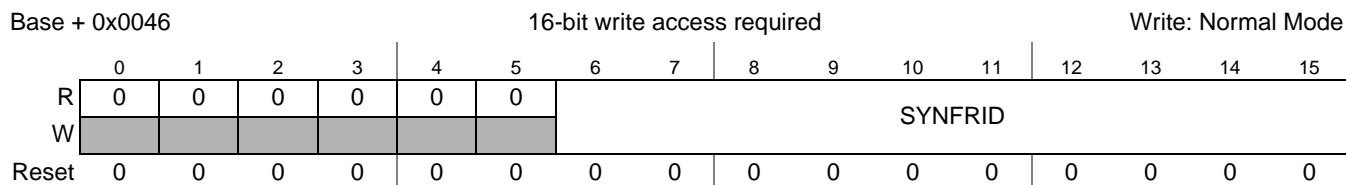
Figure 22-34. Sync Frame ID Rejection Filter Register (SFIDRFR)

This register defines the Sync Frame Rejection Filter ID. The application must update this register outside of the static segment. If the application updates this register in the static segment, it can appear that the controller accepts the sync frame in the current cycle.

Table 22-40. SFIDRFR Field Descriptions

| Field | Description |
|---------|--|
| SYNFRID | <p>Sync Frame Rejection ID — This field defines the frame ID of a frame that must not be used for clock synchronization. For details see Section 22.6.15.2, Sync Frame Rejection Filtering.</p> |

22.5.2.35 Sync Frame ID Acceptance Filter Value Register (SFIDAFVR)

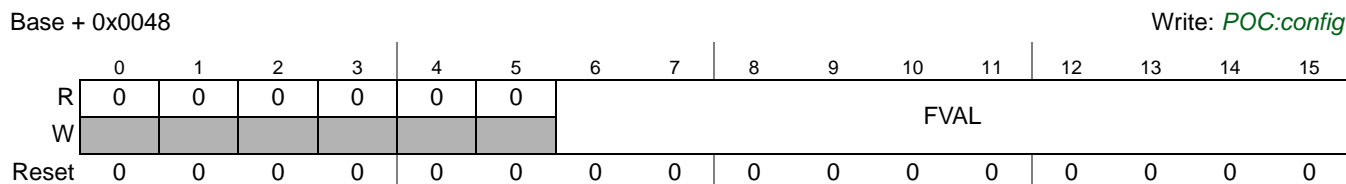

Figure 22-35. Sync Frame ID Acceptance Filter Value Register (SFIDAFVR)

This register defines the sync frame acceptance filter value. For details on filtering, see [Section 22.6.15, Sync Frame Filtering](#).

Table 22-41. SFIDAFVR Field Descriptions

| Field | Description |
|-------|---|
| FVAL | Filter Value — This field defines the value for the sync frame acceptance filtering. |

22.5.2.36 Sync Frame ID Acceptance Filter Mask Register (SFIDAFMR)

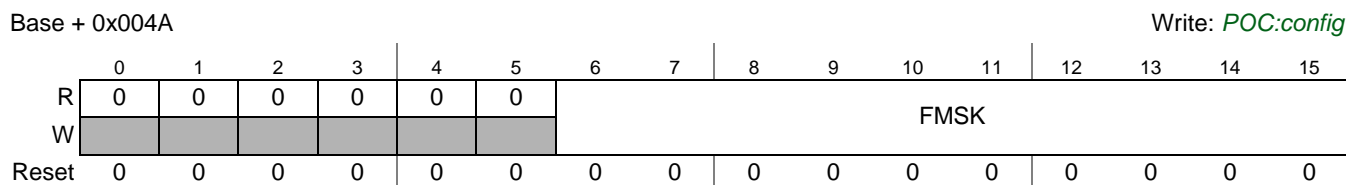

Figure 22-36. Sync Frame ID Acceptance Filter Mask Register (SFIDAFMR)

This register defines the sync frame acceptance filter mask. For details on filtering see [Section 22.6.15.1, Sync Frame Acceptance Filtering](#).

Table 22-42. SFIDAFMR Field Descriptions

| Field | Description |
|-------|---|
| FMSK | Filter Mask — This field defines the mask for the sync frame acceptance filtering. |

22.5.2.37 Network Management Vector Registers (NMVR0–NMVR5)

- Base + 0x004C (NMVR0)
- Base + 0x004E (NMVR1)
- Base + 0x0050 (NMVR2)
- Base + 0x0052 (NMVR3)
- Base + 0x0054 (NMVR4)
- Base + 0x0056 (NMVR5)

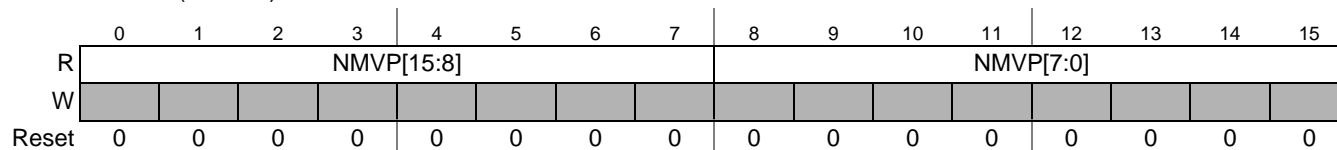

Figure 22-37. Network Management Vector Registers (NMVR0–NMVR5)

Each of these six registers holds one part of the Network Management Vector. The length of the Network Management Vector is configured in the [Network Management Vector Length Register \(NMVLR\)](#). If NMVLR is programmed with a value that is less than 12 bytes, the remaining bytes of the [Network Management Vector Registers \(NMVR0–NMVR5\)](#), which are not used for the Network Management Vector accumulating, will remain 0.

The NMVR provides accrued information over all received NMVs in the last communication cycle. All NMVs received in one cycle are ORed into the NMVR. The NMVR is updated at the end of the communication cycle.

Table 22-43. NMVR[0:5] Field Descriptions

| Field | Description |
|-------|--|
| NMVP | Network Management Vector Part — The mapping between the Network Management Vector Registers (NMVR0–NMVR5) and the receive message buffer payload bytes in NMV[0:11] is depicted in Table 22-44 . |

Table 22-44. Mapping of NMVRn to the Received Payload Bytes NMVn

| NMVRn Register | NMVRn Received Payload |
|-------------------|------------------------|
| NMVR0[NMVP[15:8]] | NMV0 |
| NMVR0[NMVP[7:0]] | NMV1 |
| NMVR1[NMVP[15:8]] | NMV2 |
| NMVR1[NMVP[7:0]] | NMV3 |
| ... | |
| NMVR5[NMVP[15:8]] | NMV10 |
| NMVR5[NMVP[7:0]] | NMV11 |

22.5.2.38 Network Management Vector Length Register (NMVLR)

Base + 0x0058

 Write: *POC:config*

| | | | | | | | | | | | | | | | | |
|-------|---|---|---|---|---|---|---|---|---|---|----|----|------|----|----|----|
| | 0 | 1 | 2 | 3 | 4 | 5 | 6 | 7 | 8 | 9 | 10 | 11 | 12 | 13 | 14 | 15 |
| R | 0 | 0 | 0 | 0 | 0 | 0 | 0 | 0 | 0 | 0 | 0 | 0 | NMVL | | | |
| W | | | | | | | | | | | | | | | | |
| Reset | 0 | 0 | 0 | 0 | 0 | 0 | 0 | 0 | 0 | 0 | 0 | 0 | 0 | 0 | 0 | 0 |

Figure 22-38. Network Management Vector Length Register (NMVLR)

This register defines the length of the network management vector in bytes.

Table 22-45. NMVLR Field Descriptions

| Field | Description |
|-------|--|
| NMVL | Network Management Vector Length — protocol related variable: gNetworkManagementVectorLength This field defines the length of the Network Management Vector in bytes. Legal values are between 0 and 12. |

22.5.2.39 Timer Configuration and Control Register (TICCR)

Base + 0x005A

Write: T2_CFG: *POC:config*

T2_REP, T1_REP, T1SP, T2SP, T1TR, T2TR: Normal Mode

| | | | | | | | | | | | | | | | | |
|-------|---|---|-----|-----|---|------|------|------|---|---|----|-----|----|------|------|------|
| | 0 | 1 | 2 | 3 | 4 | 5 | 6 | 7 | 8 | 9 | 10 | 11 | 12 | 13 | 14 | 15 |
| R | 0 | 0 | T2_ | T2_ | 0 | 0 | 0 | T2ST | 0 | 0 | 0 | T1_ | 0 | 0 | 0 | T1ST |
| W | | | CFG | REP | | T2SP | T2TR | | | | | REP | | T1SP | T1TR | |
| Reset | 0 | 0 | 0 | 0 | 0 | 0 | 0 | 0 | 0 | 0 | 0 | 0 | 0 | 0 | 0 | 0 |

Figure 22-39. Timer Configuration and Control Register (TICCR)

This register is used to configure and control the two timers T1 and T2. For timer details, see [Section 22.6.17, Timer Support](#). The Timer T1 is an absolute timer. The Timer T2 can be configured as an absolute or relative timer.

Table 22-46. TICCR Field Descriptions

| Field | Description |
|--------|--|
| T2_CFG | Timer T2 Configuration — This bit configures the timebase mode of Timer T2. 0 T2 is absolute timer. 1 T2 is relative timer. |
| T2_REP | Timer T2 Repetitive Mode — This bit configures the repetition mode of Timer T2. 0 T2 is non repetitive 1 T2 is repetitive |
| T2SP | Timer T2 Stop — This trigger bit is used to stop timer T2. 0 no effect 1 stop timer T2 |
| T2TR | Timer T2 Trigger — This trigger bit is used to start timer T2. 0 no effect 1 start timer T2 |
| T2ST | Timer T2 State — This status bit provides the current state of timer T2. 0 timer T2 is idle 1 timer T2 is running |
| T1_REP | Timer T1 Repetitive Mode — This bit configures the repetition mode of timer T1. 0 T1 is non repetitive 1 T1 is repetitive |
| T1SP | Timer T1 Stop — This trigger bit is used to stop timer T1. 0 no effect 1 stop timer T1 |
| T1TR | Timer T1 Trigger — This trigger bit is used to start timer T1. 0 no effect 1 start timer T1 |
| T1ST | Timer T1 State — This status bit provides the current state of timer T1. 0 timer T1 is idle 1 timer T1 is running |

NOTE

Both timers are deactivated immediately when the protocol enters a state different from *POC:normal active* or *POC:normal passive*.

22.5.2.40 Timer 1 Cycle Set Register (TI1CYSR)

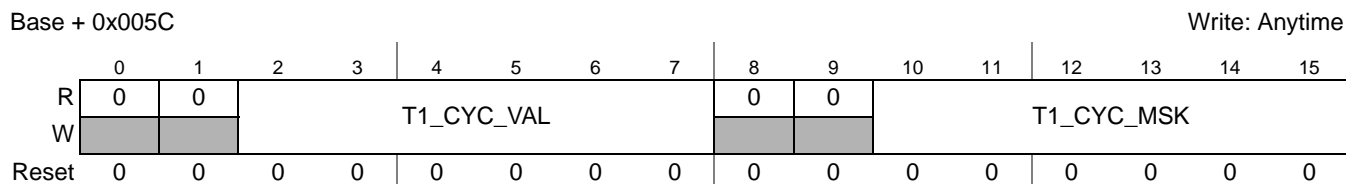

Figure 22-40. Timer 1 Cycle Set Register (TI1CYSR)

This register defines the cycle filter value and the cycle filter mask for timer T1. For a detailed description of timer T1, refer to [Section 22.6.17.1, Absolute Timer T1](#).

Table 22-47. TI1CYSR Field Descriptions

| Field | Description |
|------------|--|
| T1_CYC_VAL | Timer T1 Cycle Filter Value — This field defines the cycle filter value for timer T1. |
| T1_CYC_MSK | Timer T1 Cycle Filter Mask — This field defines the cycle filter mask for timer T1. |

NOTE

If the application modifies the value in this register while the timer is running, the change becomes effective immediately and timer T1 will expire according to the changed value.

22.5.2.41 Timer 1 Macrotick Offset Register (TI1MTOR)

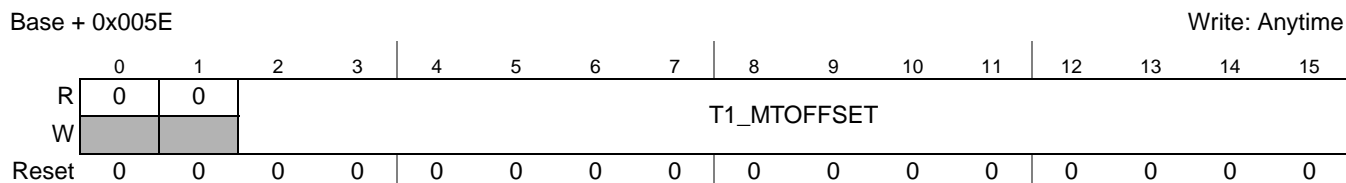

Figure 22-41. Timer 1 Macrotick Offset Register (TI1MTOR)

This register holds the macrotick offset value for timer T1. For a detailed description of timer T1, refer to [Section 22.6.17.1, Absolute Timer T1](#).

Table 22-48. TI1MTOR Field Descriptions

| Field | Description |
|-------------|--|
| T1_MTOFFSET | Timer 1 Macrotick Offset — This field defines the macrotick offset value for timer 1. |

NOTE

If the application modifies the value in this register while the timer is running, the change becomes effective immediately and timer T1 will expire according to the changed value.

22.5.2.42 Timer 2 Configuration Register 0 (TI2CR0)

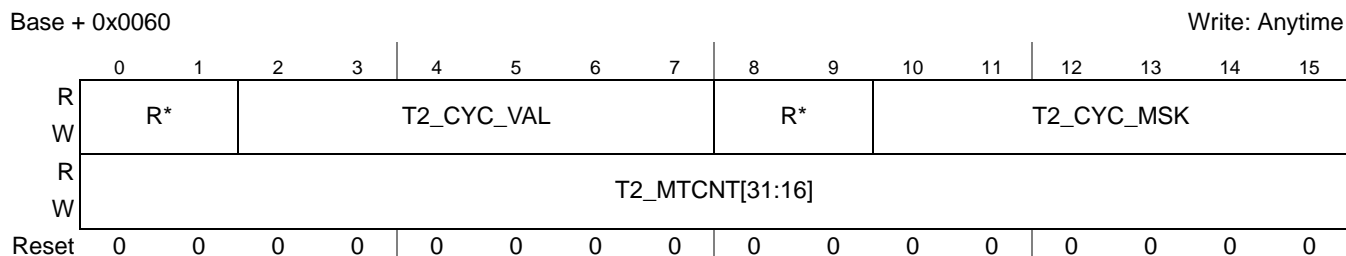

Figure 22-42. Timer 2 Configuration Register 0 (TI2CR0)

The content of this register depends on the value of the T2_CFG bit in the [Timer Configuration and Control Register \(TICCR\)](#). For a detailed description of timer T2, refer to [Section 22.6.17.2, Absolute / Relative Timer T2](#).

Table 22-49. TI2CR0 Field Descriptions

| Field | Description |
|--|---|
| Fields for absolute timer T2 (TICCR[T2_CFG] = 0) | |
| T2_CYC_VAL | Timer T2 Cycle Filter Value — This field defines the cycle filter value for timer T2. |
| T2_CYC_MSK | Timer T2 Cycle Filter Mask — This field defines the cycle filter mask for timer T2. |
| Fields for relative timer T2 (TICCR[T2_CFG] = 1) | |
| T2_MTCNT[31:16] | Timer T2 Macrotick High Word — This field defines the high word of the macrotick count for timer T2. |

NOTE

If timer T2 is configured as an *absolute* timer and the application modifies the values in this register while the timer is running, the change becomes effective immediately and timer T2 will expire according to the changed values.

If timer T2 is configured as a *relative* timer and the application changes the values in this register while the timer is running, the change becomes effective when the timer has expired according to the old values.

22.5.2.43 Timer 2 Configuration Register 1 (TI2CR1)

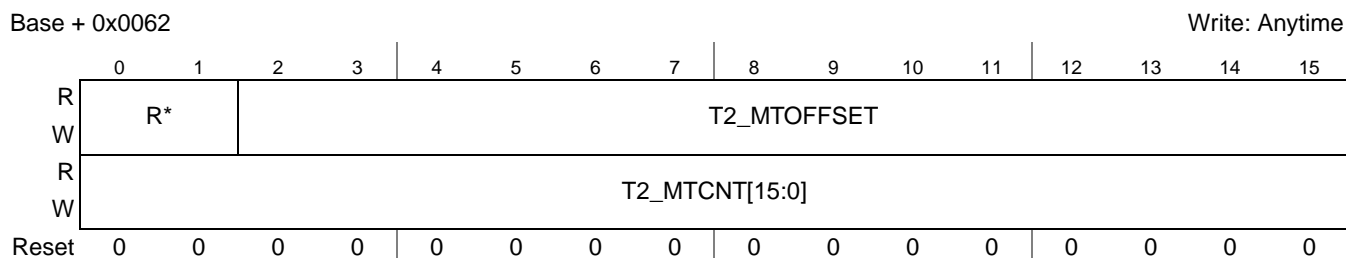

Figure 22-43. Timer 2 Configuration Register 1 (TI2CR1)

The content of this register depends on the value of the T2_CFG bit in the [Timer Configuration and Control Register \(TICCR\)](#). For a detailed description of timer T2, refer to [Section 22.6.17.2, Absolute / Relative Timer T2](#).

Table 22-50. TI2CR1 Field Descriptions

| Field | Description |
|--|---|
| Fields for absolute timer T2 (TICCR[T2_CFG] = 0) | |
| T2_MTOFFSET | Timer T2 Macrotick Offset — This field holds the macrotick offset value for timer T2. |
| Fields for relative timer T2 (TICCR[T2_CFG] = 1) | |
| T2_MTCNT[15:0] | Timer T2 Macrotick Low Word — This field defines the low word of the macrotick value for timer T2. |

NOTE

If timer T2 is configured as an *absolute* timer and the application modifies the values in this register while the timer is running, the change becomes effective immediately and the timer T2 will expire according to the changed values.

If timer T2 is configured as a *relative* timer and the application changes the values in this register while the timer is running, the change becomes effective when the timer has expired according to the old values.

22.5.2.44 Slot Status Selection Register (SSSR)

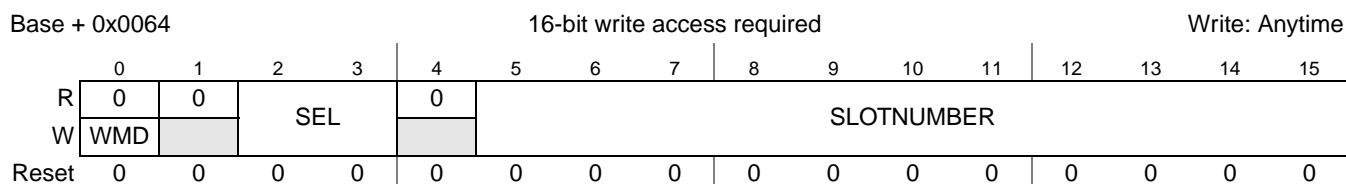

Figure 22-44. Slot Status Selection Register (SSSR)

This register is used to access the four internal non memory-mapped slot status selection registers SSSR0 to SSSR3. Each internal registers selects a slot, or symbol window/NIT, whose status vector will be saved in the corresponding [Slot Status Registers \(SSR0–SSR7\)](#) according to [Table 22-52](#). For a detailed description of slot status monitoring, refer to [Section 22.6.18, Slot Status Monitoring](#).

Table 22-51. SSSR Field Descriptions

| Field | Description |
|-------|--|
| WMD | Write Mode — This control bit defines the write mode of this register. 0 Write to all fields in this register on write access. 1 Write to SEL field only on write access. |

Table 22-51. SSSR Field Descriptions

| Field | Description |
|------------|---|
| SEL | Selector — This field selects one of the four internal slot status selection registers for access. 00 select SSSR0. 01 select SSSR1. 10 select SSSR2. 11 select SSSR3. |
| SLOTNUMBER | Slot Number — This field specifies the number of the slot whose status will be saved in the corresponding slot status registers. Note: If this value is set to 0, the related slot status register provides the status of the symbol window after the NIT start, and provides the status of the NIT after the cycle start. |

Table 22-52. Mapping Between SSSRn and SSRn

| Internal Slot Status Selection Register | Write the Slot Status of the Slot Selected by SSSRn for each | | | |
|---|--|------------------|-------------------------|------------------|
| | Even Communication Cycle | | Odd Communication Cycle | |
| | For Channel B to | For Channel A to | For Channel B to | For Channel A to |
| SSSR0 | SSR0[15:8] | SSR0[7:0] | SSR1[15:8] | SSR1[7:0] |
| SSSR1 | SSR2[15:8] | SSR2[7:0] | SSR3[15:8] | SSR3[7:0] |
| SSSR2 | SSR4[15:8] | SSR4[7:0] | SSR5[15:8] | SSR5[7:0] |
| SSSR3 | SSR6[15:8] | SSR6[7:0] | SSR7[15:8] | SSR7[7:0] |

22.5.2.45 Slot Status Counter Condition Register (SSCCR)

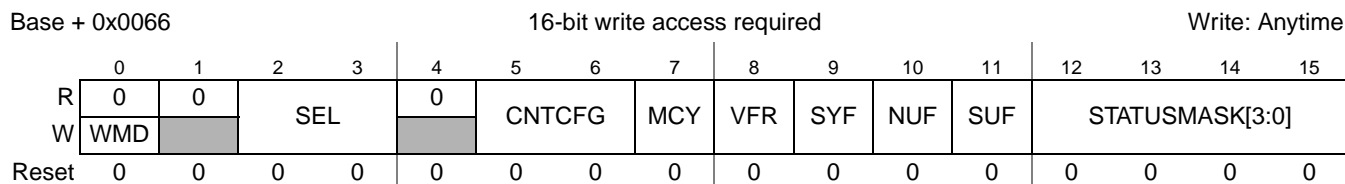

Figure 22-45. Slot Status Counter Condition Register (SSCCR)

This register is used to access and program the four internal non-memory mapped Slot Status Counter Condition Registers SSCCR0 to SSCCR3. Each of these four internal slot status counter condition registers defines the mode and the conditions for incrementing the counter in the corresponding [Slot Status Counter Registers \(SSCR0–SSCR3\)](#). The correspondence is given in [Table 22-54](#). For a detailed description of slot status counters, refer to [Section 22.6.18.4, Slot Status Counter Registers](#).

Table 22-53. SSCCR Field Descriptions

| Field | Description |
|------------------|---|
| WMD | Write Mode — This control bit defines the write mode of this register. 0 Write to all fields in this register on write access. 1 Write to SEL field only on write access. |
| SEL | Selector — This field selects one of the four internal slot counter condition registers for access. 00 select SSCCR0. 01 select SSCCR1. 10 select SSCCR2. 11 select SSCCR3. |
| CNTCFG | Counter Configuration — These bit field controls the channel related incrementing of the slot status counter. 00 increment by 1 if condition is fulfilled on channel A. 01 increment by 1 if condition is fulfilled on channel B. 10 increment by 1 if condition is fulfilled on at least one channel. 11 increment by 2 if condition is fulfilled on both channels channel. increment by 1 if condition is fulfilled on only one channel. |
| MCY | Multi Cycle Selection — This bit defines whether the slot status counter accumulates over multiple communication cycles or provides information for the previous communication cycle only. 0 The Slot Status Counter provides information for the previous communication cycle only. 1 The Slot Status Counter accumulates over multiple communication cycles. |
| VFR | Valid Frame Restriction — This bit is used to restrict the counter to received valid frames. 0 The counter is not restricted to valid frames only. 1 The counter is restricted to valid frames only. |
| SYF | Sync Frame Restriction — This bit is used to restrict the counter to received frames with the sync frame indicator bit set to 1. 0 The counter is not restricted with respect to the sync frame indicator bit. 1 The counter is restricted to frames with the sync frame indicator bit set to 1. |
| NUF | Null Frame Restriction — This bit is used to restrict the counter to received frames with the null frame indicator bit set to 0. 0 The counter is not restricted with respect to the null frame indicator bit. 1 The counter is restricted to frames with the null frame indicator bit set to 0. |
| SUF | Startup Frame Restriction — This bit is used to restrict the counter to received frames with the startup frame indicator bit set to 1. 0 The counter is not restricted with respect to the startup frame indicator bit. 1 The counter is restricted to received frames with the startup frame indicator bit set to 1. |
| STATUS MASK[3:0] | Slot Status Mask — This bit field is used to enable the counter with respect to the four slot status error indicator bits. STATUSMASK[3] — This bit enables the counting for slots with the syntax error indicator bit set to 1. STATUSMASK[2] — This bit enables the counting for slots with the content error indicator bit set to 1. STATUSMASK[1] — This bit enables the counting for slots with the boundary violation indicator bit set to 1. STATUSMASK[0] — This bit enables the counting for slots with the transmission conflict indicator bit set to 1. |

Table 22-54. Mapping between internal SSCCRn and SSCRn

| Condition Register | Condition Defined for Register |
|--------------------|--------------------------------|
| SSCCR0 | SSCR0 |
| SSCCR1 | SSCR1 |
| SSCCR2 | SSCR2 |
| SSCCR3 | SSCR3 |

22.5.2.46 Slot Status Registers (SSR0–SSR7)

- Base + 0x0068 (SSR0)
- Base + 0x006A (SSR1)
- Base + 0x006C (SSR2)
- Base + 0x006E (SSR3)
- Base + 0x0070 (SSR4)
- Base + 0x0072 (SSR5)
- Base + 0x0074 (SSR6)
- Base + 0x0076 (SSR7)

| | | | | | | | | | | | | | | | | |
|-------|-----|-----|-----|-----|-----|-----|-----|-----|-----|-----|-----|-----|-----|-----|-----|-----|
| | 0 | 1 | 2 | 3 | 4 | 5 | 6 | 7 | 8 | 9 | 10 | 11 | 12 | 13 | 14 | 15 |
| R | VFB | SYB | NFB | SUB | SEB | CEB | BVB | TCB | VFA | SYA | NFA | SUA | SEA | CEA | BVA | TCA |
| W | | | | | | | | | | | | | | | | |
| Reset | 0 | 0 | 0 | 0 | 0 | 0 | 0 | 0 | 0 | 0 | 0 | 0 | 0 | 0 | 0 | 0 |

Figure 22-46. Slot Status Registers (SSR0–SSR7)

Each of these eight registers holds the status vector of the slot specified in the corresponding internal slot status selection register, which can be programmed using the [Slot Status Selection Register \(SSSR\)](#). Each register is updated after the end of the corresponding slot as shown in [Figure 22-148](#). The register bits are directly related to the protocol variables and described in more detail in [Section 22.6.18, Slot Status Monitoring](#).

Table 22-55. SSR0–SSR7 Field Descriptions

| Field | Description |
|-------|---|
| VFB | Valid Frame on Channel B — protocol related variable: vSS!ValidFrame channel B 0 vSS!ValidFrame = 0 1 vSS!ValidFrame = 1 |
| SYB | Sync Frame Indicator Channel B — protocol related variable: vRF!Header!SyFIndicator channel B 0 vRF!Header!SyFIndicator = 0 1 vRF!Header!SyFIndicator = 1 |
| NFB | Null Frame Indicator Channel B — protocol related variable: vRF!Header!NFIndicator channel B 0 vRF!Header!NFIndicator = 0 1 vRF!Header!NFIndicator = 1 |
| SUB | Startup Frame Indicator Channel B — protocol related variable: vRF!Header!SuFIndicator channel B 0 vRF!Header!SuFIndicator = 0 1 vRF!Header!SuFIndicator = 1 |
| SEB | Syntax Error on Channel B — protocol related variable: vSS!SyntaxError channel B 0 vSS!SyntaxError = 0 1 vSS!SyntaxError = 1 |
| CEB | Content Error on Channel B — protocol related variable: vSS!ContentError channel B 0 vSS!ContentError = 0 1 vSS!ContentError = 1 |
| BVB | Boundary Violation on Channel B — protocol related variable: vSS!BViolation channel B 0 vSS!BViolation = 0 1 vSS!BViolation = 1 |
| TCB | Transmission Conflict on Channel B — protocol related variable: vSS!TxConflict channel B 0 vSS!TxConflict = 0 1 vSS!TxConflict = 1 |

Table 22-55. SSR0–SSR7 Field Descriptions (continued)

| Field | Description |
|-------|--|
| VFA | Valid Frame on Channel A — protocol related variable: <i>vSS!ValidFrame</i> channel A 0 <i>vSS!ValidFrame</i> = 0 1 <i>vSS!ValidFrame</i> = 1 |
| SYA | Sync Frame Indicator Channel A — protocol related variable: <i>vRF!Header!SyFIndicator</i> channel A 0 <i>vRF!Header!SyFIndicator</i> = 0 1 <i>vRF!Header!SyFIndicator</i> = 1 |
| NFA | Null Frame Indicator Channel A — protocol related variable: <i>vRF!Header!NFIndicator</i> channel A 0 <i>vRF!Header!NFIndicator</i> = 0 1 <i>vRF!Header!NFIndicator</i> = 1 |
| SUA | Startup Frame Indicator Channel A — protocol related variable: <i>vRF!Header!SuFIndicator</i> channel A 0 <i>vRF!Header!SuFIndicator</i> = 0 1 <i>vRF!Header!SuFIndicator</i> = 1 |
| SEA | Syntax Error on Channel A — protocol related variable: <i>vSS!SyntaxError</i> channel A 0 <i>vSS!SyntaxError</i> = 0 1 <i>vSS!SyntaxError</i> = 1 |
| CEA | Content Error on Channel A — protocol related variable: <i>vSS!ContentError</i> channel A 0 <i>vSS!ContentError</i> = 0 1 <i>vSS!ContentError</i> = 1 |
| BVA | Boundary Violation on Channel A — protocol related variable: <i>vSS!BViolation</i> channel A 0 <i>vSS!BViolation</i> = 0 1 <i>vSS!BViolation</i> = 1 |
| TCA | Transmission Conflict on Channel A — protocol related variable: <i>vSS!TxConflict</i> channel A 0 <i>vSS!TxConflict</i> = 0 1 <i>vSS!TxConflict</i> = 1 |

22.5.2.47 Slot Status Counter Registers (SSCR0–SSCR3)

Base + 0x0078 (SSCR0)

Base + 0x007A (SSCR1)

Base + 0x007C (SSCR2)

Base + 0x007E (SSCR3)

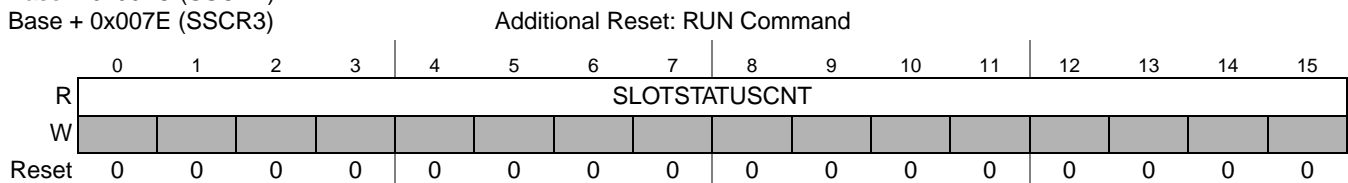
Figure 22-47. Slot Status Counter Registers (SSCR0–SSCR3)

Each of these four registers provides the slot status counter value for the previous communication cycle(s) and is updated at the cycle start. The provided value depends on the control bits and fields in the related internal slot status counter condition register SSSCRn, which can be programmed by using the [Slot Status Counter Condition Register \(SSCCR\)](#). For more details, see [Section 22.6.18.4, Slot Status Counter Registers](#).

NOTE

If the counter has reached its maximum value 0xFFFF and is in the multicycle mode, i.e. SSSCCRn[MCY] = 1, the counter is not reset to 0x0000. The application can reset the counter by clearing the SSSCCRn[MCY] bit and waiting for the next cycle start, when the controller clears the counter. Subsequently, the counter can be set into the multicycle mode again.

Table 22-56. SSCR0–SSCR3 Field Descriptions

| Field | Description |
|---------------|--|
| SLOTSTATUSCNT | Slot Status Counter — This field provides the current value of the Slot Status Counter. |

22.5.2.48 MTS A Configuration Register (MTSACFR)

Base + 0x0080

Write: MTE: Anytime
CYCCNTMSK, CYCCNTVAL: *POC:config*

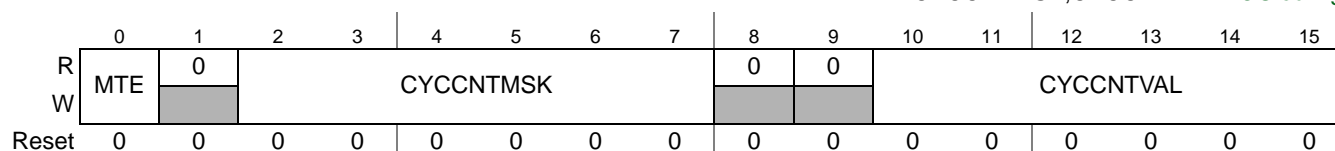

Figure 22-48. MTS A Configuration Register (MTSACFR)

This register controls the transmission of the Media Access Test Symbol MTS on channel A. For more details, see [Section 22.6.13, MTS Generation](#).

Table 22-57. MTSACFR Field Descriptions

| Field | Description |
|-----------|---|
| MTE | Media Access Test Symbol Transmission Enable — This control bit is used to enable and disable the transmission of the Media Access Test Symbol in the selected set of cycles. 0 MTS transmission disabled 1 MTS transmission enabled |
| CYCCNTMSK | Cycle Counter Mask — This field provides the filter mask for the MTS cycle count filter. |
| CYCCNTVAL | Cycle Counter Value — This field provides the filter value for the MTS cycle count filter. |

22.5.2.49 MTS B Configuration Register (MTSBCFR)

Base + 0x0082

Write: MTE: Anytime
CYCCNTMSK, CYCCNTVAL: *POC:config*

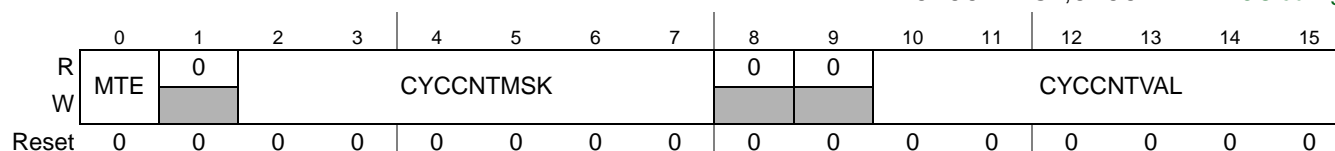

Figure 22-49. MTS B Configuration Register (MTSBCFR)

This register controls the transmission of the Media Access Test Symbol MTS on channel B. For more details, see [Section 22.6.13, MTS Generation](#).

Table 22-58. MTSCBCFR Field Descriptions

| Field | Description |
|-----------|---|
| MTE | Media Access Test Symbol Transmission Enable — This control bit is used to enable and disable the transmission of the Media Access Test Symbol in the selected set of cycles. 0 MTS transmission disabled 1 MTS transmission enabled |
| CYCCNTMSK | Cycle Counter Mask — This field provides the filter mask for the MTS cycle count filter. |
| CYCCNTVAL | Cycle Counter Value — This field provides the filter value for the MTS cycle count filter. |

22.5.2.50 Receive Shadow Buffer Index Register (RSBIR)

Base + 0x0084

16-bit write access required

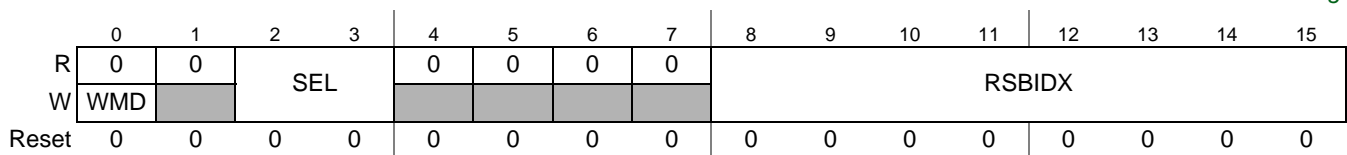
 Write: WMD, SEL: Any Time
 RSBIDX: *POC:config*

Figure 22-50. Receive Shadow Buffer Index Register (RSBIR)

This register is used to provide and retrieve the indices of the message buffer header fields currently associated with the receive shadow buffers. For more details on the receive shadow buffer concept, refer to [Section 22.6.6.3.5, Receive Shadow Buffers Concept](#).

Table 22-59. RSBIR Field Descriptions

| Field | Description |
|--------|--|
| WMD | Write Mode — This bit controls the write mode for this register. 0 update SEL and RSBIDX field on register write 1 update only SEL field on register write |
| SEL | Selector — This field is used to select the internal receive shadow buffer index register for access. 00 RSBIR_A1 — receive shadow buffer index register for channel A, segment 1 01 RSBIR_A2 — receive shadow buffer index register for channel A, segment 2 10 RSBIR_B1 — receive shadow buffer index register for channel B, segment 1 11 RSBIR_B2 — receive shadow buffer index register for channel B, segment 2 |
| RSBIDX | Receive Shadow Buffer Index — This field contains the current index of the message buffer header field of the receive shadow message buffer selected by the SEL field. The controller uses this index to determine the physical location of the shadow buffer header field in the flexray memory. The controller will update this field during receive operation. The application provides initial message buffer header index value in the configuration phase. controller: Updates the message buffer header index after successful reception. Application: Provides initial message buffer header index. |

22.5.2.51 Receive FIFO System Memory Base Address Register (RFSYMBADR)

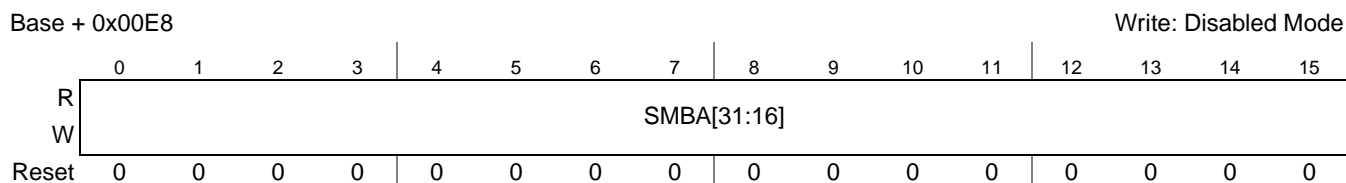

Figure 22-51. Receive FIFO System Memory Base Address High Register (RFSYMBADHR)

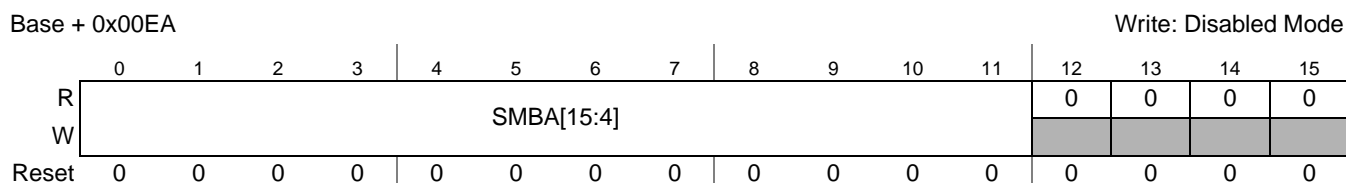

Figure 22-52. Receive FIFO System Memory Base Address Low Register (RFSYMBADLR)

These registers define the system memory base address for the receive FIFO if the FIFO address mode bit MCR[FAM] is set to 1. The system memory base address is used by the BMIF to calculate the physical memory address for system memory accesses for the FIFOs.

Table 22-60. RFSYMBADR Field Descriptions

| Field | Description |
|-------|---|
| SMBA | System Memory Base Address — This is the value of the system memory base address for the receive FIFO if the FIFO address mode bit MCR[FAM] is set to 1. It defines as a byte address. |

22.5.2.52 Receive FIFO Periodic Timer Register (RFPTR)

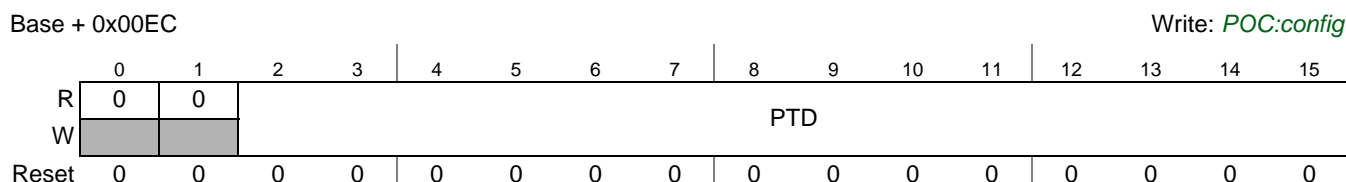

Figure 22-53. Receive FIFO Periodic Timer Register (RFPTR)

This register holds periodic timer duration for the periodic FIFO timer. The periodic timer applies to both FIFOs (see [Section 22.6.9.3, FIFO Periodic Timer](#)).

Table 22-61. RFPTR Field Descriptions

| Field | Description |
|-------|---|
| PTD | Periodic Timer Duration — This value defines the periodic timer duration in terms of macroticks. 0000 timer stays expired 3FFF timer never expires other timer expires after specified number of macroticks, expires and is restarted at each cycle start |

22.5.2.53 Receive FIFO Watermark and Selection Register (RFWMSR)

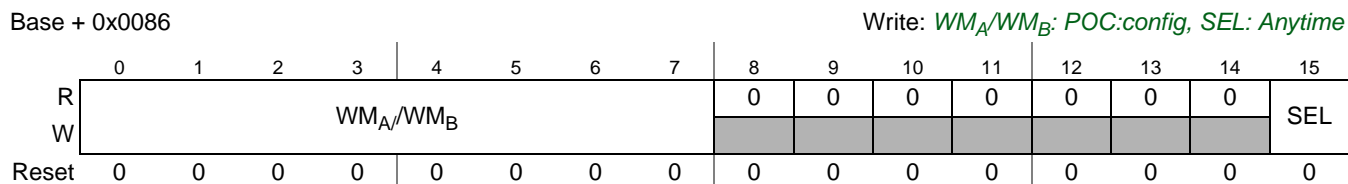

Figure 22-54. Receive FIFO Watermark and Selection Register (RFWMSR)

This register is used to

- select a receiver FIFO for subsequent programming access through the receiver FIFO configuration registers summarized in [Table 22-62](#).
- to define the watermark for the selected FIFO.

Table 22-62. SEL Controlled Receiver FIFO Registers

| Register |
|--|
| Receive FIFO Start Index Register (RFSIR) |
| Receive FIFO Depth and Size Register (RFDSR) |
| Receive FIFO Message ID Acceptance Filter Value Register (RFMIDAFVR) |
| Receive FIFO Message ID Acceptance Filter Mask Register (RFMIAFMR) |
| Receive FIFO Frame ID Rejection Filter Value Register (RFFIDRFVR) |
| Receive FIFO Frame ID Rejection Filter Mask Register (RFFIDRFMR) |
| Receive FIFO Range Filter Configuration Register (RFRFCFR) |
| Receive FIFO Range Filter Control Register (RFRFCTR) |

Table 22-63. RFSR Field Descriptions

| Field | Description |
|------------------------------------|--|
| WM _A WM _B | Watermark — This field defines the watermark value for the selected FIFO. This value is used to control the generation of the almost full interrupt flags. |
| SEL | Select — This control bit selects the receiver FIFO for subsequent programming. 0 Receiver FIFO for channel A selected 1 Receiver FIFO for channel B selected |

22.5.2.54 Receive FIFO Start Index Register (RFSIR)

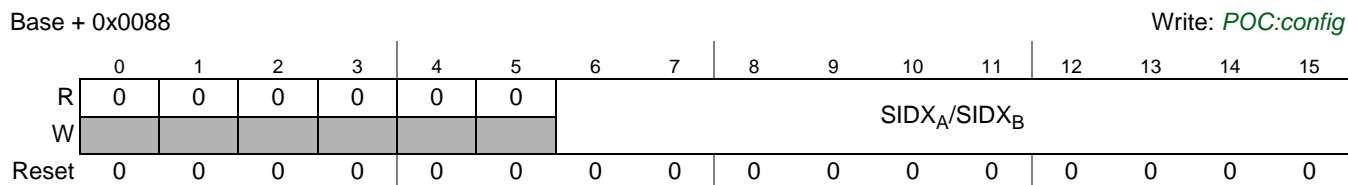

Figure 22-55. Receive FIFO Start Index Register (RFSIR)

This register defines the message buffer header index of the first message buffer of the selected FIFO.

Table 22-64. RFSIR Field Descriptions

| Field | Description |
|--|--|
| SIDX _A SIDX _B | Start Index — This field defines the number of the message buffer header field of the first message buffer of the selected FIFO. The controller uses the value of the SIDX field to determine the physical location of the receiver FIFO's first message buffer header field. |

22.5.2.55 Receive FIFO Depth and Size Register (RFDSR)

Base + 0x008A

Write: *POC:config*

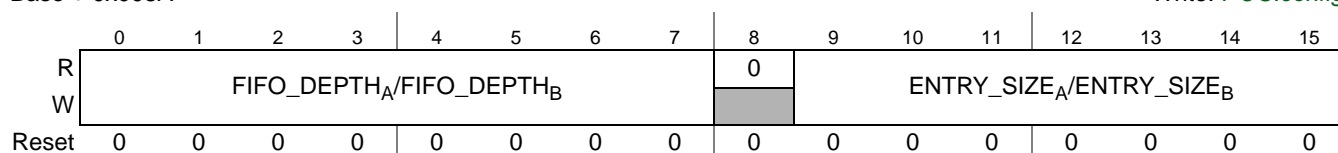

Figure 22-56. Receive FIFO Depth and Size Register (RFDSR)

This register defines the structure of the selected FIFO, i.e. the number of entries and the size of each entry.

Table 22-65. RFDSR Field Descriptions

| Field | Description |
|--|--|
| FIFO_DEPTH _A FIFO_DEPTH _B | FIFO Depth — This field defines the depth of the selected FIFO, i.e. the number of entries. |
| ENTRY_SIZE _A ENTRY_SIZE _B | Entry Size — This field defines the size of the frame data sections for the selected FIFO in 2 byte entities. |

22.5.2.56 Receive FIFO A Read Index Register (RFARIR)

Base + 0x008C

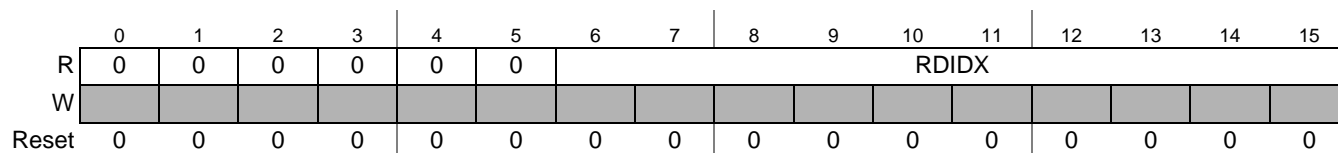

Figure 22-57. Receive FIFO A Read Index Register (RFARIR)

This register provides the message buffer header index of the next available FIFO A entry that the application can read.

Table 22-66. RFARIR Field Descriptions

| Field | Description |
|-------|--|
| RDIDX | Read Index — This field provides the message buffer header index of the next available FIFO message buffer that the application can read. If the old style FIFO mode is configured (MCR.FIMD=0), the controller updates this index by 1 entry, when the application writes to the FAFAIF flag in the Global Interrupt Flag and Enable Register (GIFER) . If the new style FIFO mode is configured (MCR.FIMD=1), the controller updates this index by PCA entries, when the application writes to the Receive FIFO Fill Level and POP Count Register (RFFLPCR) . |

NOTE

If the FIFO is empty, the RDIDX field points to an physical message buffer with invalid content.

22.5.2.57 Receive FIFO B Read Index Register (RFBRIR)

Base + 0x008E

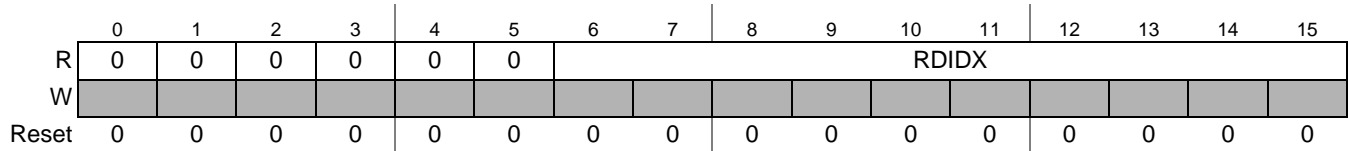

Figure 22-58. Receive FIFO B Read Index Register (RFBRIR)

This register provides the message buffer header index of the next available FIFO B entry that the application can read.

Table 22-67. RFBRIR Field Descriptions

| Field | Description |
|-------|--|
| RDIDX | Read Index — This field provides the message buffer header index of the next available FIFO message buffer that the application can read. |

NOTE

If the FIFO is empty, the RDIDX field points to an physical message buffer with invalid content.

22.5.2.58 Receive FIFO Fill Level and POP Count Register (RFFLPCR)

Base + 0x00EE

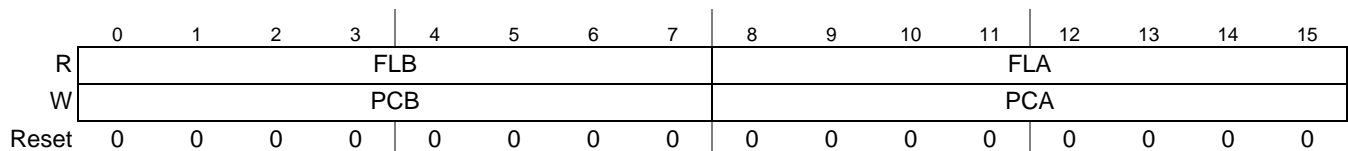

Figure 22-59. Receive FIFO Fill Level and POP Count Register (RFFLPCR)

This register provides the current fill level of the two receiver FIFOs and is used to pop a number of entries from the FIFOs.

Table 22-68. RFFLPCR Field Descriptions

| Field | Description |
|-------|---|
| FLB | Fill Level FIFO B — This field provides the current number of entries in the FIFO B. |
| FLA | Fill Level FIFO A — This field provides the current number of entries in the FIFO A. |
| PCB | Pop Count FIFO B — This field defines the number of entries to be removed from FIFO B. |
| PCA | Pop Count FIFO A — This field defines the number of entries to be removed from FIFO A. |

NOTE

If the pop count value PCA/PCB is greater than the current FIFO fill level FLB/FLA, then the FIFO is empty after the update. No notification is given that not the required number of entries was removed.

22.5.2.59 Receive FIFO Message ID Acceptance Filter Value Register (RFMIDAFVR)

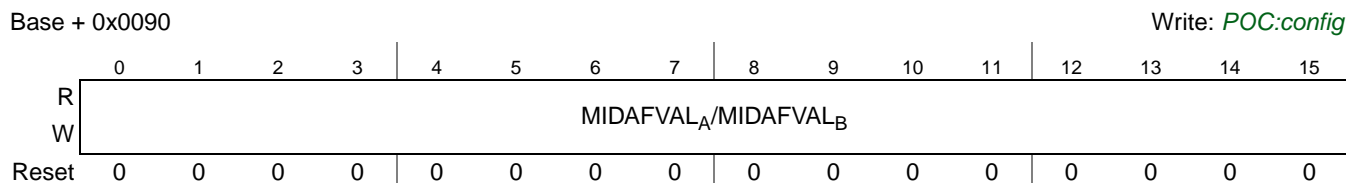

Figure 22-60. Receive FIFO Message ID Acceptance Filter Value Register (RFMIDAFVR)

This register defines the filter value for the message ID acceptance filter of the selected FIFO. For details on message ID filtering see [Section 22.6.9.9, FIFO Filtering](#).

Table 22-69. RFMIDAFVR Field Descriptions

| Field | Description |
|--|--|
| MIDAFVAL _A MIDAFVAL _B | Message ID Acceptance Filter Value — Filter value for the message ID acceptance filter. |

22.5.2.60 Receive FIFO Message ID Acceptance Filter Mask Register (RFMIAFMR)

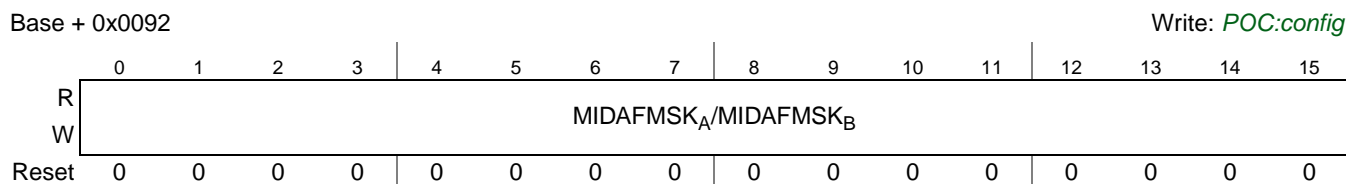

Figure 22-61. Receive FIFO Message ID Acceptance Filter Mask Register (RFMIAFMR)

This register defines the filter mask for the message ID acceptance filter of the selected FIFO. For details on message ID filtering see [Section 22.6.9.9, FIFO Filtering](#).

Table 22-70. RFMIAFMR Field Descriptions

| Field | Description |
|--|--|
| MIDAFMSK _A MIDAFMSK _B | Message ID Acceptance Filter Mask — Filter mask for the message ID acceptance filter. |

22.5.2.61 Receive FIFO Frame ID Rejection Filter Value Register (RFFIDRFVR)

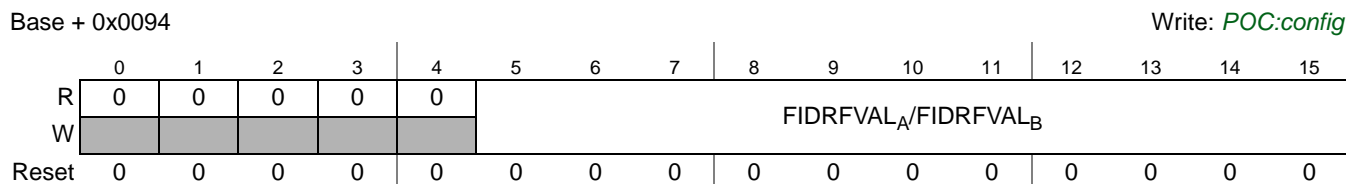

Figure 22-62. Receive FIFO Frame ID Rejection Filter Value Register (RFFIDRFVR)

This register defines the filter value for the frame ID rejection filter of the selected FIFO. For details on frame ID filtering see [Section 22.6.9.9, FIFO Filtering](#).

Table 22-71. RFFIDRFVR Field Descriptions

| Field | Description |
|--|--|
| FIDRFVAL _A FIDRFVAL _B | Frame ID Rejection Filter Value — Filter value for the frame ID rejection filter. |

22.5.2.62 Receive FIFO Frame ID Rejection Filter Mask Register (RFFIDRFMR)

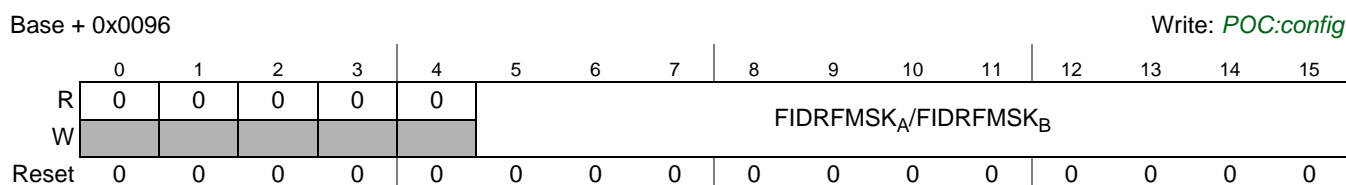

Figure 22-63. Receive FIFO Frame ID Rejection Filter Mask Register (RFFIDRFMR)

This register defines the filter mask for the frame ID rejection filter of the selected FIFO. For details on frame ID filtering see [Section 22.6.9.9, FIFO Filtering](#).

Table 22-72. RFFIDRFMR Field Descriptions

| Field | Description |
|----------|--|
| FIDRFMSK | Frame ID Rejection Filter Mask — Filter mask for the frame ID rejection filter. |

22.5.2.63 Receive FIFO Range Filter Configuration Register (RFRFCFR)

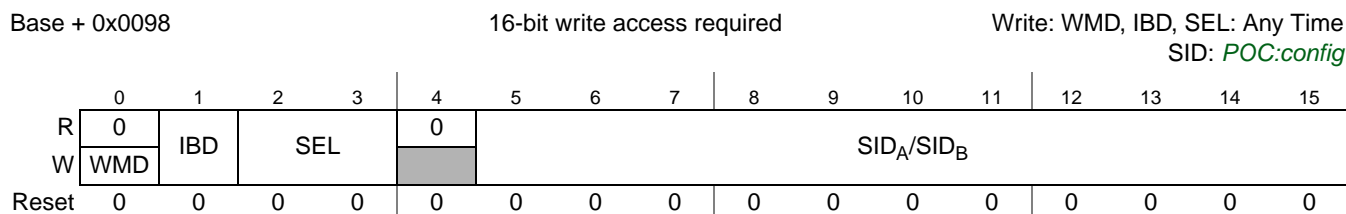

Figure 22-64. Receive FIFO Range Filter Configuration Register (RFRFCFR)

This register provides access to the four internal frame ID range filter boundary registers of the selected FIFO. For details on frame ID range filter see [Section 22.6.9.9, FIFO Filtering](#).

Table 22-73. RFRFCFR Field Descriptions

| Field | Description |
|--------------------------------------|---|
| WMD | Write Mode — This control bit defines the write mode of this register. 0 Write to all fields in this register on write access. 1 Write to SEL and IBD field only on write access. |
| IBD | Interval Boundary — This control bit selects the interval boundary to be programmed with the SID value. 0 program lower interval boundary 1 program upper interval boundary |
| SEL | Filter Selector — This control field selects the frame ID range filter to be accessed. 00 select frame ID range filter 0. 01 select frame ID range filter 1. 10 select frame ID range filter 2. 11 select frame ID range filter 3. |
| SID _A SID _B | Slot ID — Defines the IBD-selected frame ID boundary value for the SEL-selected range filter. |

22.5.2.64 Receive FIFO Range Filter Control Register (RFRFCTR)

Base + 0x009A

Write: Anytime

| | | | | | | | | | | | | | | | | |
|-------|---|---|---|---|------|------|------|------|---|---|----|----|------|------|------|------|
| | 0 | 1 | 2 | 3 | 4 | 5 | 6 | 7 | 8 | 9 | 10 | 11 | 12 | 13 | 14 | 15 |
| R | 0 | 0 | 0 | 0 | F3MD | F2MD | F1MD | F0MD | 0 | 0 | 0 | 0 | F3EN | F2EN | F1EN | F0EN |
| W | | | | | | | | | | | | | | | | |
| Reset | 0 | 0 | 0 | 0 | 0 | 0 | 0 | 0 | 0 | 0 | 0 | 0 | 0 | 0 | 0 | 0 |

Figure 22-65. Receive FIFO Range Filter Control Register (RFRFCTR)

This register is used to enable and disable each frame ID range filter and to define whether it is running as acceptance or rejection filter.

Table 22-74. RFRFCTR Field Descriptions

| Field | Description |
|-------|--|
| F3MD | Range Filter 3 Mode — This control bit defines the filter mode of the frame ID range filter 3. 0 range filter 3 runs as acceptance filter 1 range filter 3 runs as rejection filter |
| F2MD | Range Filter 2 Mode — This control bit defines the filter mode of the frame ID range filter 2. 0 range filter 2 runs as acceptance filter 1 range filter 2 runs as rejection filter |
| F1MD | Range Filter 1 Mode — This control bit defines the filter mode of the frame ID range filter 1. 0 range filter 1 runs as acceptance filter 1 range filter 1 runs as rejection filter |
| F0MD | Range Filter 0 Mode — This control bit defines the filter mode of the frame ID range filter 0. 0 range filter 0 runs as acceptance filter 1 range filter 0 runs as rejection filter |
| F3EN | Range Filter 3 Enable — This control bit is used to enable and disable the frame ID range filter 3. 0 range filter 3 disabled 1 range filter 3 enabled |
| F2EN | Range Filter 2 Enable — This control bit is used to enable and disable the frame ID range filter 2. 0 range filter 2 disabled 1 range filter 2 enabled |

Table 22-74. RFRFCTR Field Descriptions (continued)

| Field | Description |
|-------|---|
| F1EN | Range Filter 1 Enable — This control bit is used to enable and disable the frame ID range filter 1. 0 range filter 1 disabled 1 range filter 1 enabled |
| F0EN | Range Filter 0 Enable — This control bit is used to enable and disable the frame ID range filter 0. 0 range filter 0 disabled 1 range filter 0 enabled |

22.5.2.65 Last Dynamic Transmit Slot Channel A Register (LDTXSLAR)

Base + 0x009C

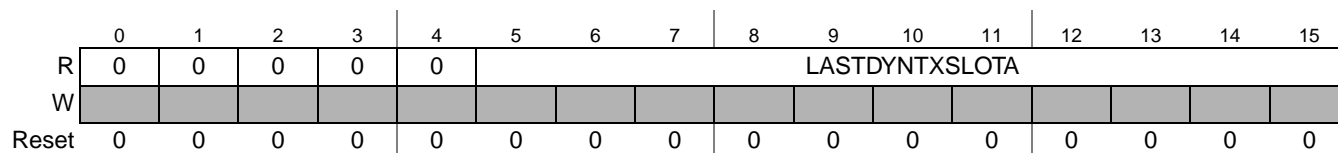
Figure 22-66. Last Dynamic Slot Channel A Register (LDTXSLAR)

This register provides the number of the last transmission slot in the dynamic segment for channel A. This register is updated after the end of the dynamic segment and before the start of the next communication cycle.

Table 22-75. LDTXSLAR Field Descriptions

| Field | Description |
|-----------------|--|
| LASTDYNTX SLOTA | Last Dynamic Transmission Slot Channel A — protocol related variable: <i>zLastDynTxSlot</i> channel A Number of the last transmission slot in the dynamic segment for channel A. If no frame was transmitted during the dynamic segment on channel A, the value of this field is set to 0. |

22.5.2.66 Last Dynamic Transmit Slot Channel B Register (LDTXSLBR)

Base + 0x009E

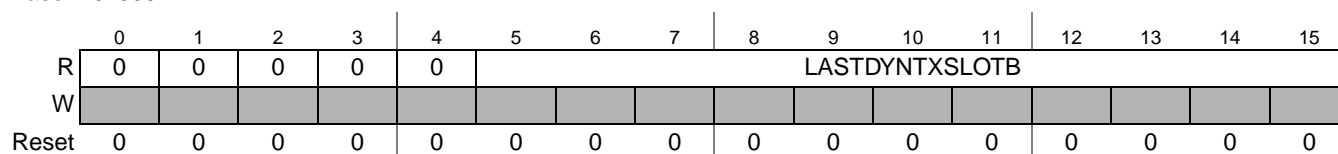
Figure 22-67. Last Dynamic Slot Channel B Register (LDTXSLBR)

This register provides the number of the last transmission slot in the dynamic segment for channel B. This register is updated after the end of the dynamic segment and before the start of the next communication cycle.

Table 22-76. LDTXSLBR Field Descriptions

| Field | Description |
|-----------------|---|
| LASTDYNTX SLOTB | Last Dynamic Transmission Slot Channel B — protocol related variable: <i>zLastDynTxSlot</i> channel B Number of the last transmission slot in the dynamic segment for channel B. If no frame was transmitted during the dynamic segment on channel B the value of this field is set to 0. |

22.5.2.67 Protocol Configuration Registers

The following configuration registers provide the necessary configuration information to the protocol engine. The individual values in the registers are described in [Table 22-77](#). For more details about the FlexRay related configuration parameters and the allowed parameter ranges, see *FlexRay Communications System Protocol Specification, Version 2.1 Rev A*.

Table 22-77. Protocol Configuration Register Fields

| Name | Description ¹ | Min | Max | Unit | PCR |
|--------------------------------------|---|-----|-----|-----------------------|-------|
| coldstart_attempts | gColdstartAttempts | | | number | 3 |
| action_point_offset | gdActionPointOffset - 1 | | | MT | 0 |
| cas_rx_low_max | gdCASRxLowMax - 1 | | | gdBit | 4 |
| dynamic_slot_idle_phase | gdDynamicSlotIdlePhase | | | minislot | 28 |
| minislot_action_point_offset | gdMinislotActionPointOffset - 1 | | | MT | 3 |
| minislot_after_action_point | gdMinislot - gdMinislotActionPointOffset - 1 | | | MT | 2 |
| static_slot_length | gdStaticSlot | | | MT | 0 |
| static_slot_after_action_point | gdStaticSlot - gdActionPointOffset - 1 | | | MT | 13 |
| symbol_window_exists | gdSymbolWindow !=0 | 0 | 1 | bool | 9 |
| symbol_window_after_action_point | gdSymbolWindow - gdActionPointOffset - 1 | | | MT | 6 |
| tss_transmitter | gdTSSTransmitter | | | gdBit | 5 |
| wakeup_symbol_rx_idle | gdWakeupSymbolRxIdle | | | gdBit | 5 |
| wakeup_symbol_rx_low | gdWakeupSymbolRxLow | | | gdBit | 3 |
| wakeup_symbol_rx_window | gdWakeupSymbolRxWindow | | | gdBit | 4 |
| wakeup_symbol_tx_idle | gdWakeupSymbolTxIdle | | | gdBit | 8 |
| wakeup_symbol_tx_low | gdWakeupSymbolTxLow | | | gdBit | 5 |
| noise_listen_timeout | (gListenNoise * pdListenTimeout) - 1 | | | μT | 16/17 |
| macro_initial_offset_a | pMacroInitialOffset[A] | | | MT | 6 |
| macro_initial_offset_b | pMacroInitialOffset[B] | | | MT | 16 |
| macro_per_cycle | gMacroPerCycle | | | MT | 10 |
| macro_after_first_static_slot | gMacroPerCycle - gdStaticSlot | | | MT | 1 |
| macro_after_offset_correction | gMacroPerCycle - gOffsetCorrectionStart | | | MT | 28 |
| max_without_clock_correction_fatal | gMaxWithoutClockCorrectionFatal | | | cyclepairs | 8 |
| max_without_clock_correction_passive | gMaxWithoutClockCorrectionPassive | | | cyclepairs | 8 |
| minislot_exists | gNumberOfMinislots !=0 | 0 | 1 | bool | 9 |
| minislots_max | gNumberOfMinislots - 1 | | | minislot | 29 |
| number_of_static_slots | gNumberOfStaticSlots | | | static slot | 2 |
| offset_correction_start | gOffsetCorrectionStart | | | MT | 11 |
| payload_length_static | gPayloadLengthStatic | | | 2-bytes | 19 |
| max_payload_length_dynamic | pPayloadLengthDynMax | | | 2-bytes | 24 |
| first_minislot_action_point_offset | max(gdActionPointOffset , gdMinislotActionPointOffset) - 1 | | | MT | 13 |
| allow_halt_due_to_clock | pAllowHaltDueToClock | | | bool | 26 |
| allow_passive_to_active | pAllowPassiveToActive | | | cyclepairs | 12 |

Table 22-77. Protocol Configuration Register Fields (continued)

| Name | Description ¹ | Min | Max | Unit | PCR |
|-------------------------------|--|-----------------|-------|----------|-------|
| cluster_drift_damping | <i>pClusterDriftDamping</i> | | | μT | 24 |
| comp_accepted_startup_range_a | <i>pdAcceptedStartupRange - pDelayCompensation[A]</i> | | | μT | 22 |
| comp_accepted_startup_range_b | <i>pdAcceptedStartupRange - pDelayCompensation[B]</i> | | | μT | 26 |
| listen_timeout | <i>pdListenTimeout - 1</i> | | | μT | 14/15 |
| key_slot_id | <i>pKeySlotId</i> | | | number | 18 |
| key_slot_used_for_startup | <i>pKeySlotUsedForStartup</i> | | | bool | 11 |
| key_slot_used_for_sync | <i>pKeySlotUsedForSync</i> | | | bool | 11 |
| latest_tx | <i>gNumberOfMinislots - pLatestTx</i> | | | minislot | 21 |
| sync_node_max | <i>gSyncNodeMax</i> | | | number | 30 |
| micro_initial_offset_a | <i>pMicroInitialOffset[A]</i> | | | μT | 20 |
| micro_initial_offset_b | <i>pMicroInitialOffset[B]</i> | | | μT | 20 |
| micro_per_cycle | <i>pMicroPerCycle</i> | | | μT | 22/23 |
| micro_per_cycle_min | <i>pMicroPerCycle - pdMaxDrift</i> | | | μT | 24/25 |
| micro_per_cycle_max | <i>pMicroPerCycle + pdMaxDrift</i> | | | μT | 26/27 |
| micro_per_macro_nom_half | $\text{round}(pMicroPerMacroNom / 2)$ | | | μT | 7 |
| offset_correction_out | <i>pOffsetCorrectionOut</i> | | | μT | 9 |
| rate_correction_out | <i>pRateCorrectionOut</i> | | | μT | 14 |
| single_slot_enabled | <i>pSingleSlotEnabled</i> | | | bool | 10 |
| wakeup_channel | <i>pWakeupChannel</i> | see Table 22-78 | | | 10 |
| wakeup_pattern | <i>pWakeupPattern</i> | | | number | 18 |
| decoding_correction_a | <i>pDecodingCorrection + pDelayCompensation[A] + 2</i> | | | μT | 19 |
| decoding_correction_b | <i>pDecodingCorrection + pDelayCompensation[B] + 2</i> | | | μT | 7 |
| key_slot_header_crc | header CRC for key slot | 0x000 | 0x7FF | number | 12 |
| extern_offset_correction | <i>pExternOffsetCorrection</i> | | | μT | 29 |
| extern_rate_correction | <i>pExternRateCorrection</i> | | | μT | 21 |

¹ See *FlexRay Communications System Protocol Specification, Version 2.1 Rev A* for detailed protocol parameter definitions

Table 22-78. Wakeup Channel Selection

| wakeup_channel | Wakeup Channel |
|----------------|----------------|
| 0 | A |
| 1 | B |

22.5.2.67.1 Protocol Configuration Register 0 (PCR0)

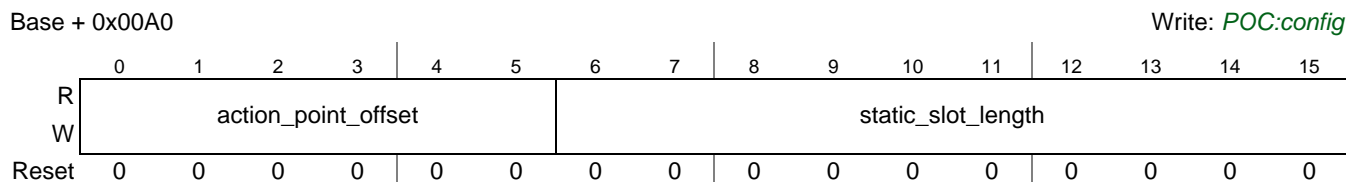

Figure 22-68. Protocol Configuration Register 0 (PCR0)

22.5.2.67.2 Protocol Configuration Register 1 (PCR1)

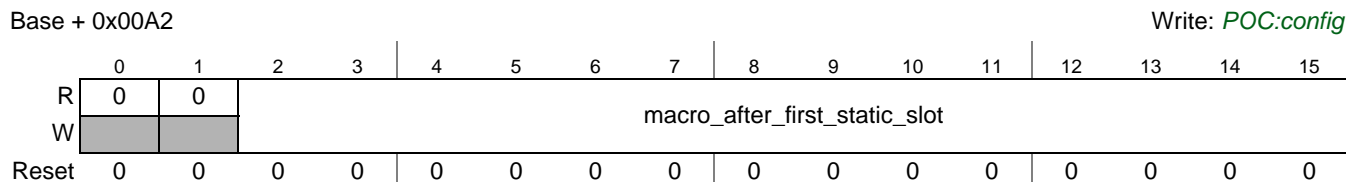

Figure 22-69. Protocol Configuration Register 1 (PCR1)

22.5.2.67.3 Protocol Configuration Register 2 (PCR2)

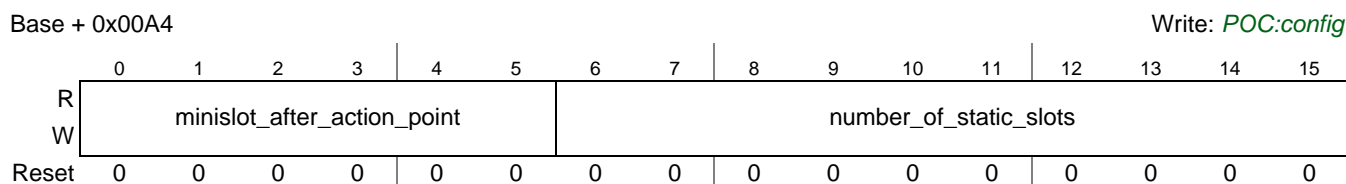

Figure 22-70. Protocol Configuration Register 2 (PCR2)

22.5.2.67.4 Protocol Configuration Register 3 (PCR3)

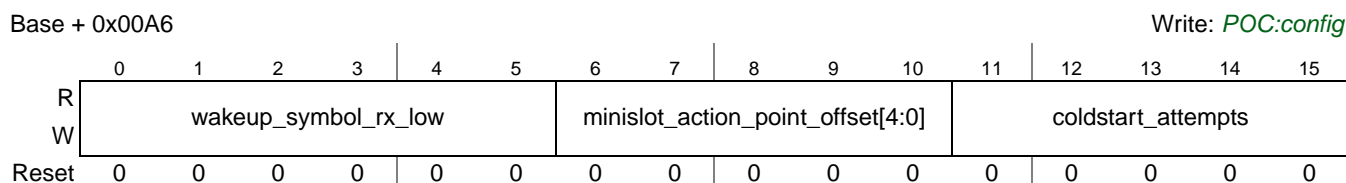

Figure 22-71. Protocol Configuration Register 3 (PCR3)

22.5.2.67.5 Protocol Configuration Register 4 (PCR4)

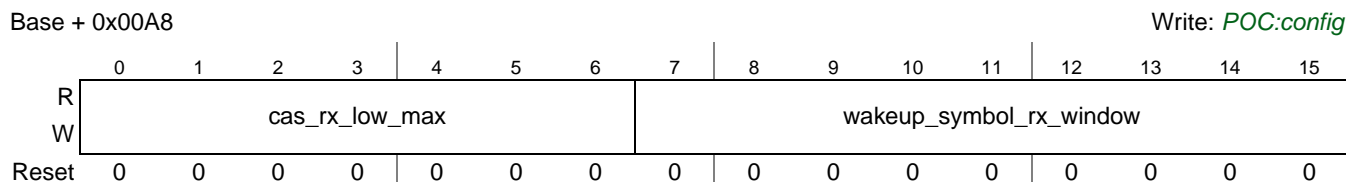

Figure 22-72. Protocol Configuration Register 4 (PCR4)

22.5.2.67.6 Protocol Configuration Register 5 (PCR5)

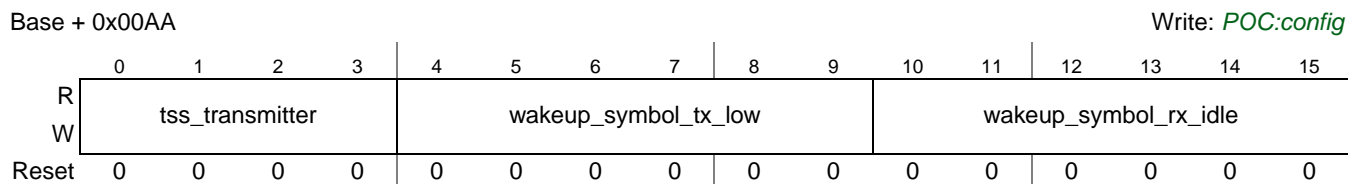

Figure 22-73. Protocol Configuration Register 5 (PCR5)

22.5.2.67.7 Protocol Configuration Register 6 (PCR6)

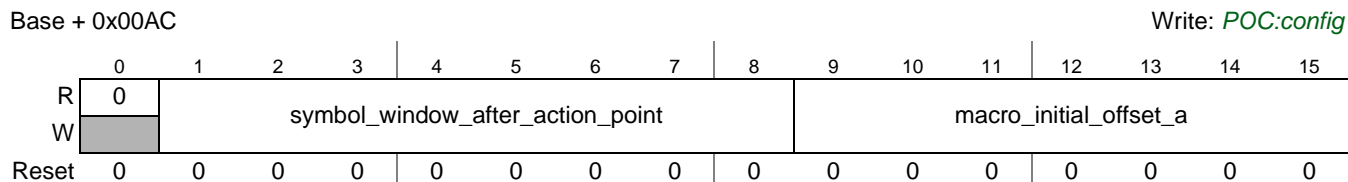

Figure 22-74. Protocol Configuration Register 6 (PCR6)

22.5.2.67.8 Protocol Configuration Register 7 (PCR7)

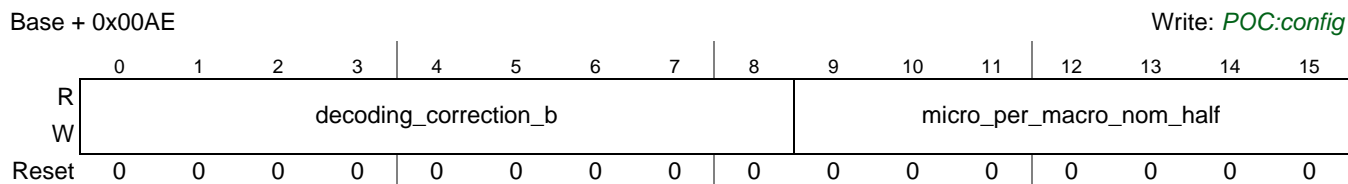

Figure 22-75. Protocol Configuration Register 7 (PCR7)

22.5.2.67.9 Protocol Configuration Register 8 (PCR8)

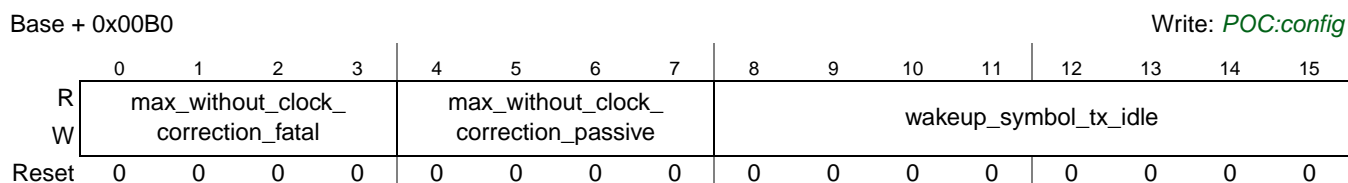

Figure 22-76. Protocol Configuration Register 8 (PCR8)

22.5.2.67.10 Protocol Configuration Register 9 (PCR9)

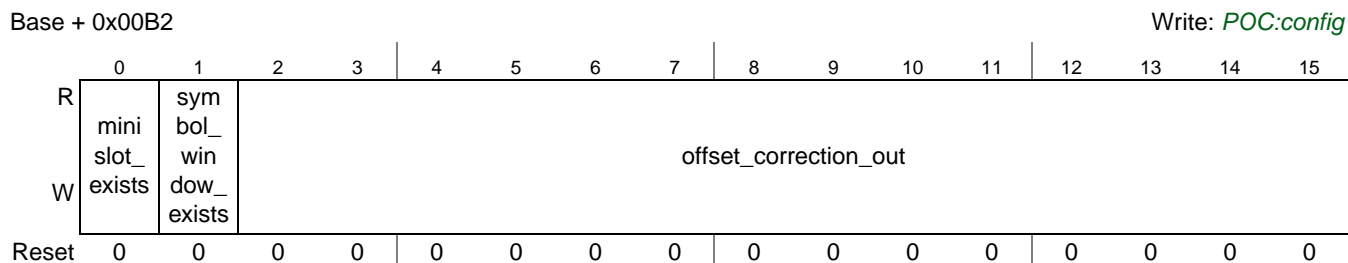

Figure 22-77. Protocol Configuration Register 9 (PCR9)

22.5.2.67.11 Protocol Configuration Register 10 (PCR10)

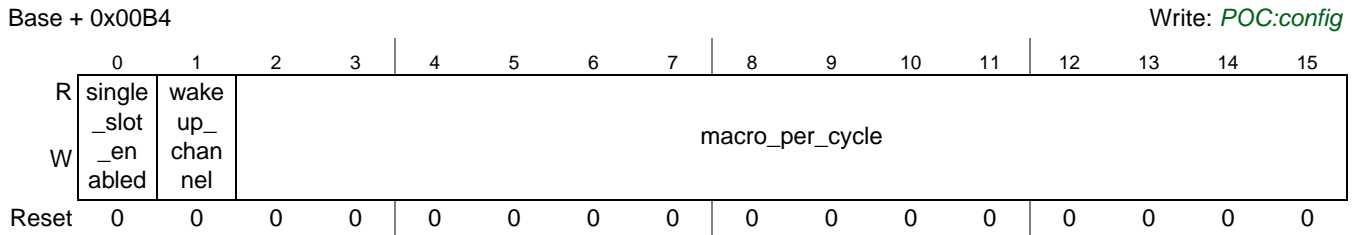

Figure 22-78. Protocol Configuration Register 10 (PCR10)

22.5.2.67.12 Protocol Configuration Register 11 (PCR11)

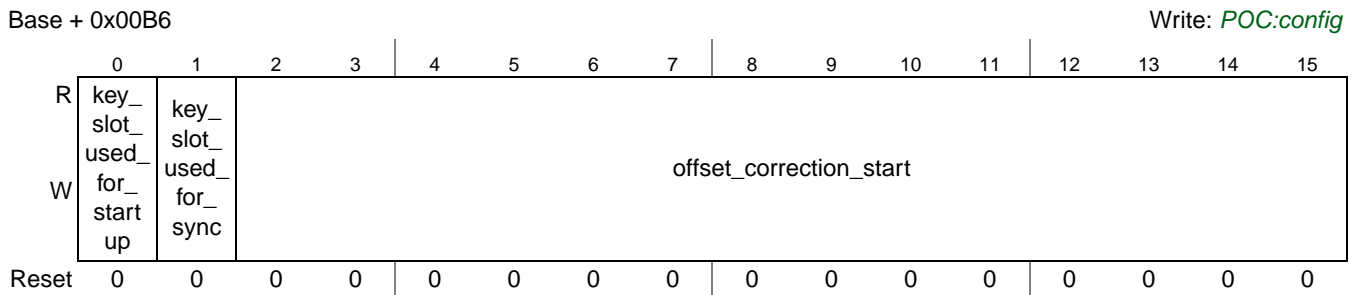

Figure 22-79. Protocol Configuration Register 11 (PCR11)

22.5.2.67.13 Protocol Configuration Register 12 (PCR12)

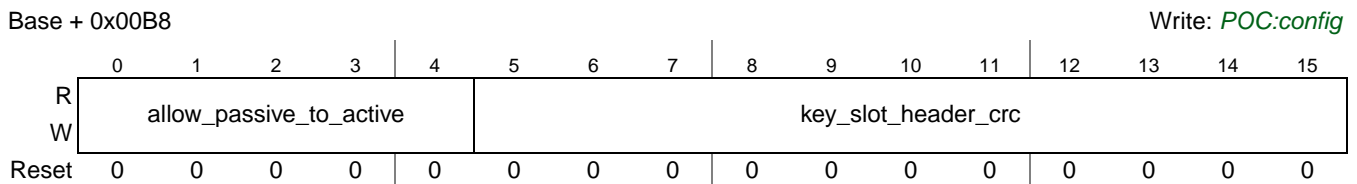

Figure 22-80. Protocol Configuration Register 12 (PCR12)

22.5.2.67.14 Protocol Configuration Register 13 (PCR13)

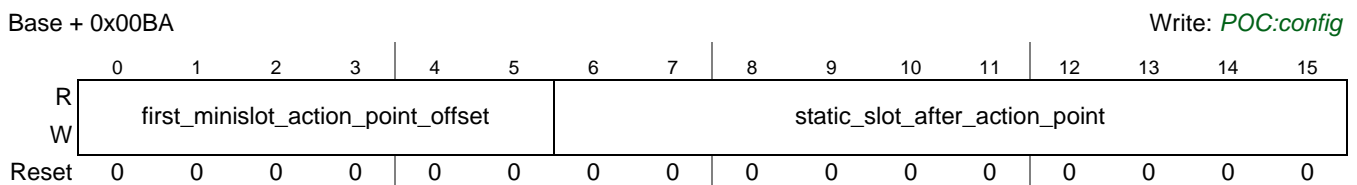

Figure 22-81. Protocol Configuration Register 13 (PCR13)

22.5.2.67.15 Protocol Configuration Register 14 (PCR14)

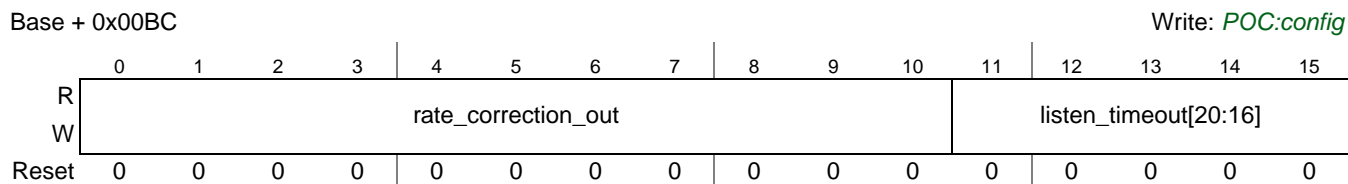

Figure 22-82. Protocol Configuration Register 14 (PCR14)

22.5.2.67.16 Protocol Configuration Register 15 (PCR15)

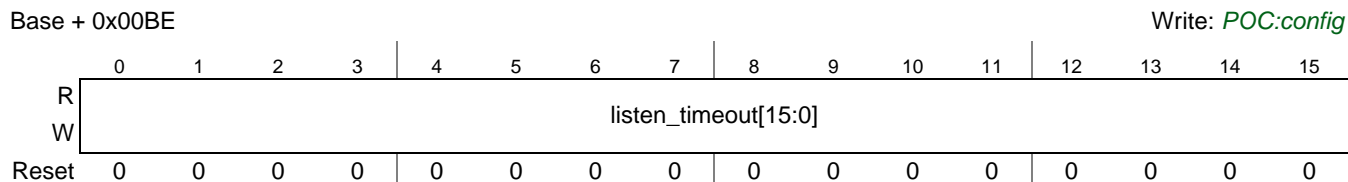

Figure 22-83. Protocol Configuration Register 15 (PCR15)

22.5.2.67.17 Protocol Configuration Register 16 (PCR16)

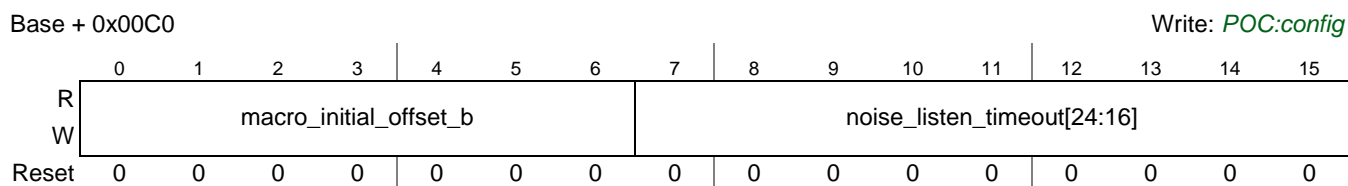

Figure 22-84. Protocol Configuration Register 16 (PCR16)

22.5.2.67.18 Protocol Configuration Register 17 (PCR17)

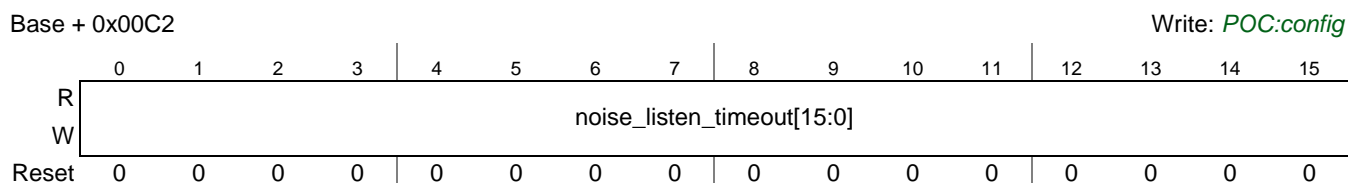

Figure 22-85. Protocol Configuration Register 17 (PCR17)

22.5.2.67.19 Protocol Configuration Register 18 (PCR18)

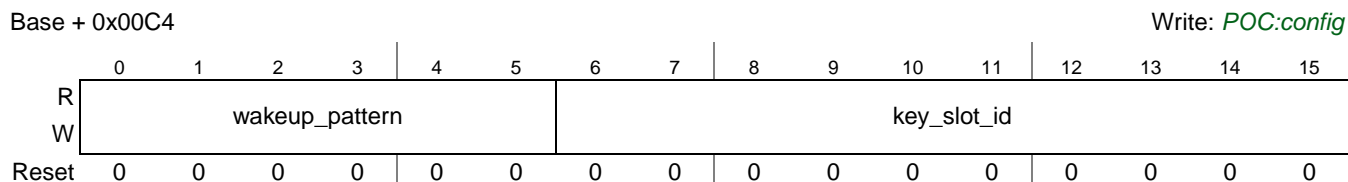

Figure 22-86. Protocol Configuration Register 18 (PCR18)

22.5.2.67.20 Protocol Configuration Register 19 (PCR19)

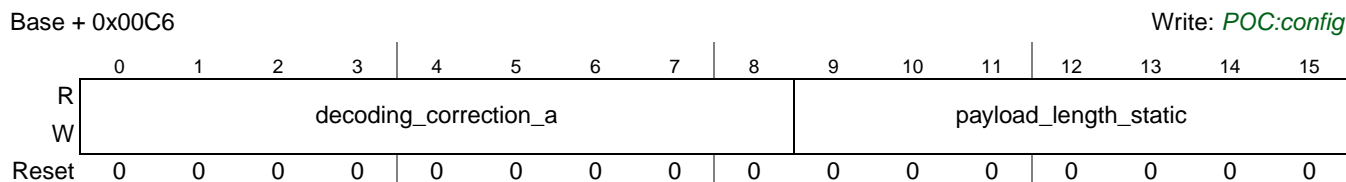

Figure 22-87. Protocol Configuration Register 19 (PCR19)

22.5.2.67.21 Protocol Configuration Register 20 (PCR20)

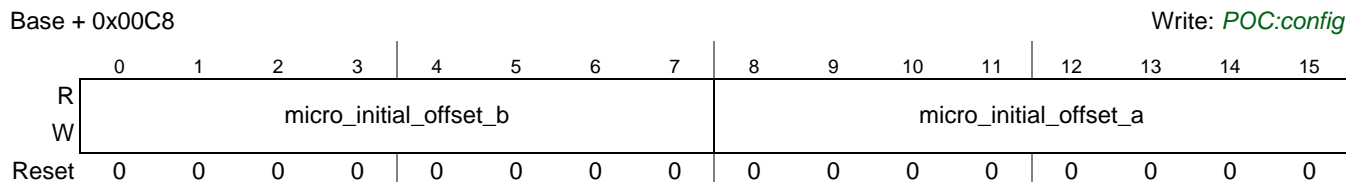

Figure 22-88. Protocol Configuration Register 20 (PCR20)

22.5.2.67.22 Protocol Configuration Register 21 (PCR21)

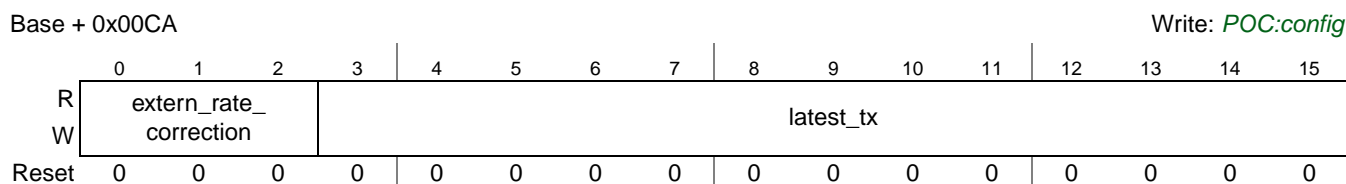

Figure 22-89. Protocol Configuration Register 21 (PCR21)

22.5.2.67.23 Protocol Configuration Register 22 (PCR22)

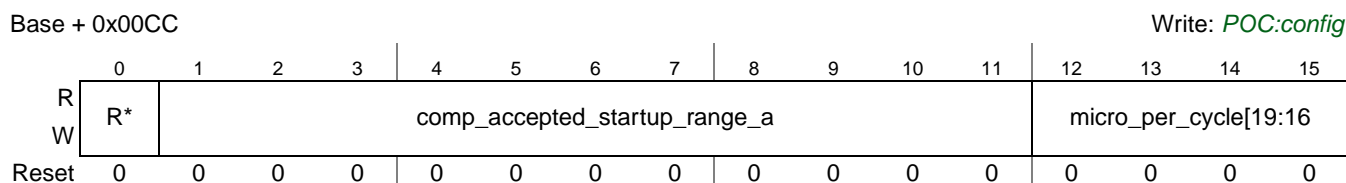

Figure 22-90. Protocol Configuration Register 22 (PCR22)

22.5.2.67.24 Protocol Configuration Register 23 (PCR23)

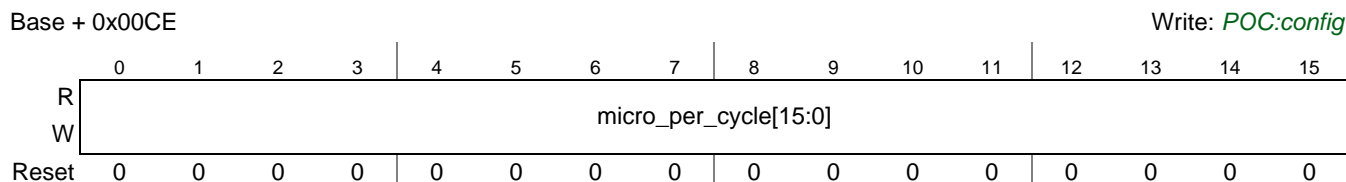

Figure 22-91. Protocol Configuration Register 23 (PCR23)

22.5.2.67.25 Protocol Configuration Register 24 (PCR24)

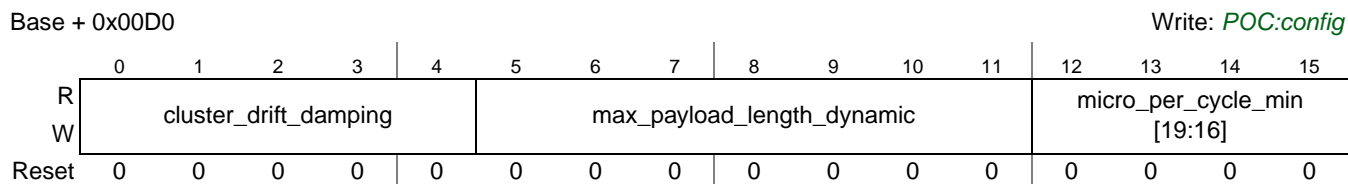

Figure 22-92. Protocol Configuration Register 24 (PCR24)

22.5.2.67.26 Protocol Configuration Register 25 (PCR25)

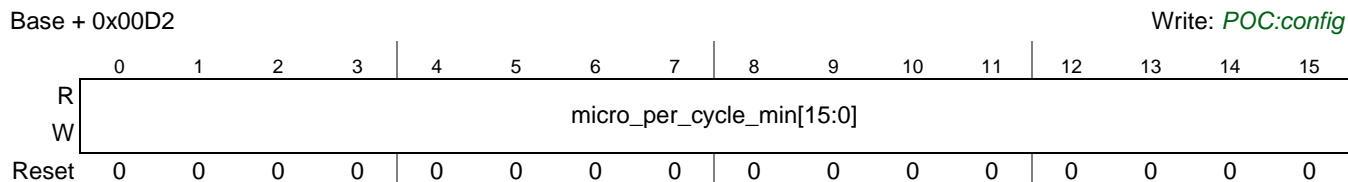

Figure 22-93. Protocol Configuration Register 25 (PCR25)

22.5.2.67.27 Protocol Configuration Register 26 (PCR26)

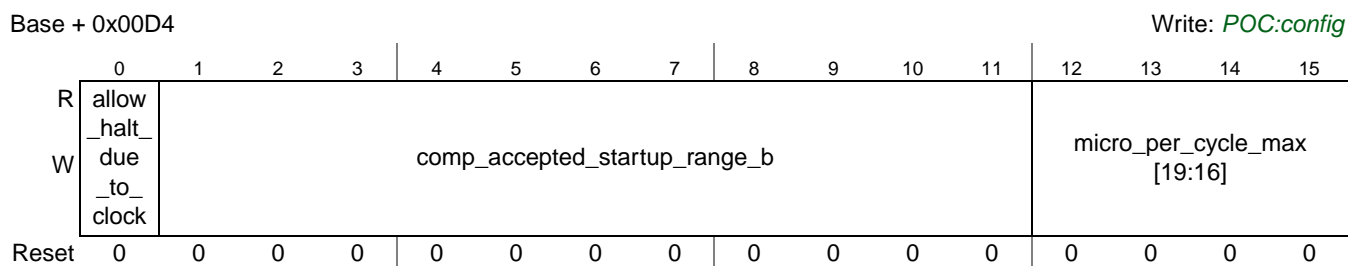

Figure 22-94. Protocol Configuration Register 26 (PCR26)

22.5.2.67.28 Protocol Configuration Register 27 (PCR27)

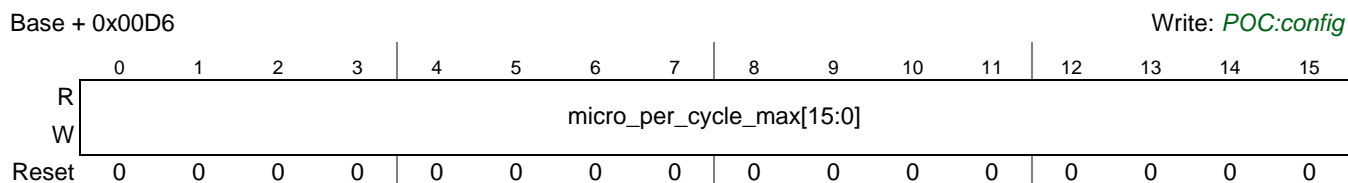

Figure 22-95. Protocol Configuration Register 27 (PCR27)

22.5.2.67.29 Protocol Configuration Register 28 (PCR28)

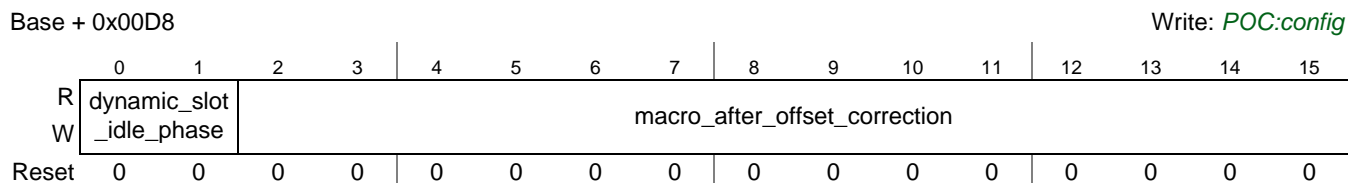

Figure 22-96. Protocol Configuration Register 28 (PCR28)

22.5.2.67.30 Protocol Configuration Register 29 (PCR29)

Base + 0x00DA Write: *POC:config*

| | | | | | | | | | | | | | | | | |
|-------|--------------------------|---|---|---------------|---|---|---|---|---|---|----|----|----|----|----|----|
| | 0 | 1 | 2 | 3 | 4 | 5 | 6 | 7 | 8 | 9 | 10 | 11 | 12 | 13 | 14 | 15 |
| R | extern_offset_correction | | | minislots_max | | | | | | | | | | | | |
| W | extern_offset_correction | | | minislots_max | | | | | | | | | | | | |
| Reset | 0 | 0 | 0 | 0 | 0 | 0 | 0 | 0 | 0 | 0 | 0 | 0 | 0 | 0 | 0 | 0 |

Figure 22-97. Protocol Configuration Register 29 (PCR29)

22.5.2.67.31 Protocol Configuration Register 30 (PCR30)

Base + 0x00DC Write: *POC:config*

| | | | | | | | | | | | | | | | | |
|-------|------------|---|---|---|---|---|---|---|---|---|----|---------------|---------------|----|----|----|
| | 0 | 1 | 2 | 3 | 4 | 5 | 6 | 7 | 8 | 9 | 10 | 11 | 12 | 13 | 14 | 15 |
| R | 0 | 0 | 0 | 0 | 0 | 0 | 0 | 0 | 0 | 0 | 0 | 0 | sync_node_max | | | |
| W | [Reserved] | | | | | | | | | | | sync_node_max | | | | |
| Reset | 0 | 0 | 0 | 0 | 0 | 0 | 0 | 0 | 0 | 0 | 0 | 0 | 0 | 0 | 0 | 0 |

Figure 22-98. Protocol Configuration Register 30 (PCR30)

22.5.2.68 Message Buffer Configuration, Control, Status Registers (MBCCSRn)

Base + 0x0100 (MBCCSR0) Write: MCM, MBT, MTD: *POC:config* or MB_DIS
 Base + 0x0108 (MBCCSR1) CMT: MB_LCK or MB_DIS
 ... EDT, LCKT, MBIE, MBIF: Normal Mode
 Base + 0x04F8 (MBCCSR127)

Additional Reset: CMT, DUP, DVAL, MBIF: Message Buffer Disable

| | | | | | | | | | | | | | | | | |
|-------|------------|-----|-----|-----|-----|-----|------|------|------------|------------|------------|------------|------------|------------|------------|------|
| | 0 | 1 | 2 | 3 | 4 | 5 | 6 | 7 | 8 | 9 | 10 | 11 | 12 | 13 | 14 | 15 |
| R | 0 | MCM | MBT | MTD | CMT | 0 | 0 | MBIE | 0 | 0 | 0 | DUP | DVAL | EDS | LCKS | MBIF |
| W | [Reserved] | MCM | MBT | MTD | rwm | EDT | LCKT | MBIE | [Reserved] | [Reserved] | [Reserved] | [Reserved] | [Reserved] | [Reserved] | [Reserved] | w1c |
| Reset | 0 | 0 | 0 | 0 | 0 | 0 | 0 | 0 | 0 | 0 | 0 | 0 | 0 | 0 | 0 | 0 |

Figure 22-99. Message Buffer Configuration, Control, Status Registers (MBCCSRn)

The content of these registers comprises message buffer configuration data, message buffer control data, message buffer status information, and message buffer interrupt flags. A detailed description of all flags can be found in [Section 22.6.6, Individual Message Buffer Functional Description](#)

If the application writes 1 to the EDT bit, no write access to the other register bits is performed.

If the application writes 0 to the EDT bit and 1 to the LCKT bit, no write access to the other bits is performed.

Table 22-79. MBCCSRn Field Descriptions

| Field | Description |
|-------------------------------------|---|
| Message Buffer Configuration | |
| MCM | Message Buffer Commit Mode — This bit configures the commit mode of a double buffered message buffer. 0 Streaming commit mode 1 Immediate commit mode |
| MBT | Message Buffer Type — This bit configures the buffering type of a transmit message buffer. 0 Single buffered message buffer 1 Double buffered message buffer |
| MTD | Message Buffer Transfer Direction — This bit configures the transfer direction of a message buffer. 0 Receive message buffer 1 Transmit message buffer |
| Message Buffer Control | |
| CMT | Commit for Transmission — This bit indicates if the transmit message buffer data are ready for transmission. 0 Message buffer data not ready for transmission 1 Message buffer data ready for transmission |
| EDT | Enable/Disable Trigger — If the application writes 1 to this bit, a message buffer enable or disable is triggered, depending on the current value EDS status bit is 0. 0 No effect 1 Message buffer enable or disable is triggered |
| LCKT | Lock/Unlock Trigger — If the application writes 1 to this bit, a message buffer lock or unlock is triggered, depending on the current value of the LCKS status bit. 0 No effect 1 Message buffer lock or unlock is triggered |
| MBIE | Message Buffer Interrupt Enable — This control bit defines whether the message buffer will generate an interrupt request when its MBIF flag is set. 0 Interrupt request generation disabled 1 Interrupt request generation enabled |
| Message Buffer Status | |
| DUP | Data Updated — This status bit indicates whether the frame header in the message buffer header field and the data in the message buffer data field were updated after a frame reception. 0 Frame Header and Message buffer data field not updated 1 Frame Header and Message buffer data field updated |
| DVAL | Data Valid — For receive message buffers this status bit indicates whether the message buffer data field contains valid frame data. For transmit message buffers the status bit indicates if a message is transferred again due to the state transmission mode of the message buffer. 0 receive message buffer contains no valid frame data / message is transmitted for the first time 1 receive message buffer contains valid frame data / message will be transferred again |
| EDS | Enable/Disable Status — This status bit indicates whether the message buffer is enabled or disabled. 0 Message buffer is disabled. 1 Message buffer is enabled. |
| LCKS | Lock Status — This status bit indicates the current lock status of the message buffer. 0 Message buffer is not locked by the application. 1 Message buffer is locked by the application. |
| MBIF | Message Buffer Interrupt Flag — This flag is set when the slot status field of the message buffer was updated after frame transmission or reception, or when a transmit message buffer was just enabled by the application. 0 No such event 1 Slot status field updated or transmit message buffer just enabled |

22.5.2.69 Message Buffer Cycle Counter Filter Registers (MBCCFRn)

Base + 0x0102 (MBCCFR0)

Base + 0x010A (MBCCFR1)

...

Base + 0x04FA (MBCCFR127)

Write: *POC:config* or MB_DIS

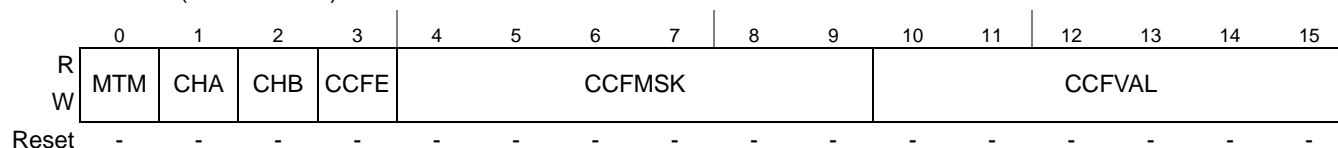

Figure 22-100. Message Buffer Cycle Counter Filter Registers (MBCCFRn)

This register contains message buffer configuration data for the transmission mode, the channel assignment, and for the cycle counter filtering. For detailed information on cycle counter filtering, refer to [Section 22.6.7.1, Message Buffer Cycle Counter Filtering](#).

Table 22-80. MBCCFRn Field Descriptions

| Field | Description |
|------------|--|
| MTM | Message Buffer Transmission Mode — This control bit applies only to transmit message buffers and defines the transmission mode. 0 Event transmission mode 1 State transmission mode |
| CHA CHB | Channel Assignment — These control bits define the channel assignment and control the receive and transmit behavior of the message buffer according to Table 22-81 . |
| CCFE | Cycle Counter Filtering Enable — This control bit is used to enable and disable the cycle counter filtering. 0 Cycle counter filtering disabled 1 Cycle counter filtering enabled |
| CCFMSK | Cycle Counter Filtering Mask — This field defines the filter mask for the cycle counter filtering. |
| CCFVAL | Cycle Counter Filtering Value — This field defines the filter value for the cycle counter filtering. |

Table 22-81. Channel Assignment Description

| CHA | CHB | Transmit Message Buffer | | Receive Message Buffer | |
|-----|-----|--|----------------------------|---|---|
| | | static segment | dynamic segment | static segment | dynamic segment |
| 1 | 1 | transmit on both channel A and channel B | transmit on channel A only | store first valid frame received on either channel A or channel B | store first valid frame received on channel A, ignore channel B |
| 0 | 1 | transmit on channel B | transmit on channel B | store first valid frame received on channel B | store first valid frame received on channel B |
| 1 | 0 | transmit on channel A | transmit on channel A | store first valid frame received on channel A | store first valid frame received on channel A |
| 0 | 0 | no frame transmission | no frame transmission | no frame stored | no frame stored |

NOTE

If at least one message buffer assigned to a certain slot is assigned to both channels, then all message buffers assigned to this slot have to be assigned to both channels. Otherwise, the message buffer configuration is illegal and the result of the message buffer search is not defined.

22.5.2.70 Message Buffer Frame ID Registers (MBFIDRn)

Base + 0x0104 (MBFIDR0)

 Write: *POC:config* or MB_DIS

Base + 0x010C (MBFIDR1)

...

Base + 0x04FC (MBFIDR127)

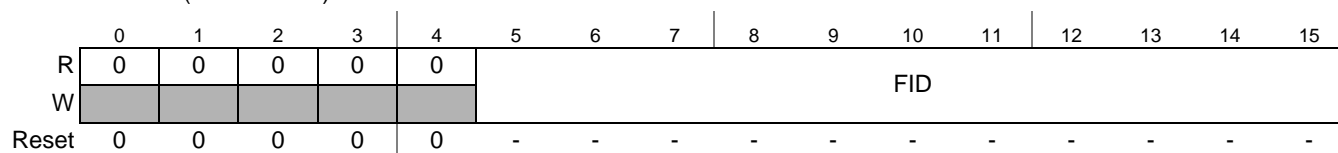

Figure 22-101. Message Buffer Frame ID Registers (MBFIDRn)

Table 22-82. MBFIDRn Field Descriptions

| Field | Description |
|-------|---|
| FID | <p>Frame ID — The semantic of this field depends on the message buffer transfer type.</p> <ul style="list-style-type: none"> <i>Receive Message Buffer</i>: This field is used as a filter value to determine if the message buffer is used for reception of a message received in a slot with the slot ID equal to FID. <i>Transmit Message Buffer</i>: This field is used to determine the slot in which the message in this message buffer should be transmitted. |

22.5.2.71 Message Buffer Index Registers (MBIDXRn)

Base + 0x0106 (MBIDXR0)

 Write: *POC:config* or MB_DIS

Base + 0x010E (MBIDXR1)

...

Base + 0x04FE (MBIDXR127)

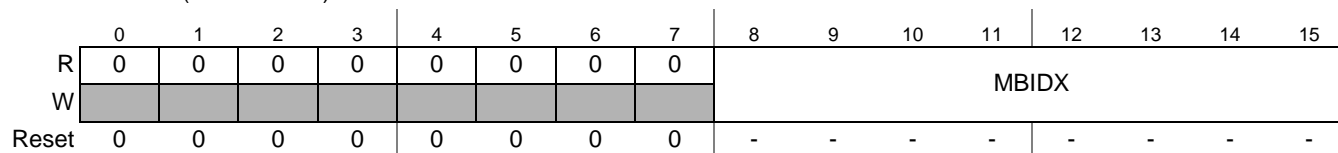

Figure 22-102. Message Buffer Index Registers (MBIDXRn)

Table 22-83. MBIDXRn Field Descriptions

| Field | Description |
|-------|---|
| MBIDX | <p>Message Buffer Index — This field provides the index of the message buffer header field of the physical message buffer that is currently associated with this message buffer.</p> <p>The application writes the index of the initially associated message buffer header field into this register. The controller updates this register after frame reception or transmission.</p> |

22.6 Functional Description

This section provides a detailed description of the functionality implemented in the controller.

22.6.1 Message Buffer Concept

The controller uses a data structure called *message buffer* to store frame data, configuration, control, and status data. Each message buffer consists of two parts, the *message buffer control data* and the *physical message buffer*. The message buffer control data are located in dedicated registers. The structure of the message buffer control data depends on the message buffer type and is described in [Section 22.6.3, Message Buffer Types](#). The physical message buffer is located in the flexray memory and is described in [Section 22.6.2, Physical Message Buffer](#).

22.6.2 Physical Message Buffer

All FlexRay messages and related frame and slot status information of received frames and of frames to be transmitted to the FlexRay bus are stored in data structures called *physical message buffers*. The physical message buffers are located in the flexray memory. The structure of a physical message buffer is depicted in [Figure 22-103](#).

A physical message buffer consists of two fields, the *message buffer header field* and the *message buffer data field*. The message buffer header field contains the *frame header*, the *data field offset*, and the *slot status*. The message buffer data field contains the *frame data*.

The connection between the two fields is established by the *data field offset*.

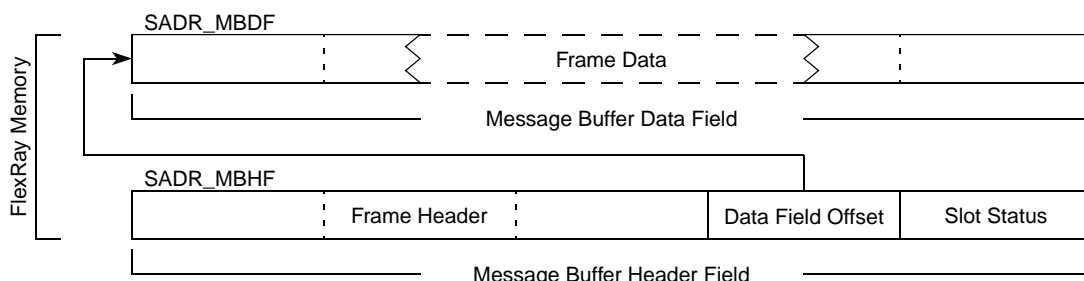

Figure 22-103. Physical Message Buffer Structure

22.6.2.1 Message Buffer Header Field

The message buffer header field is a contiguous region in the flexray memory and occupies ten bytes. It contains the frame header, the data field offset, and the slot status. Its structure is shown in [Figure 22-103](#). The physical start address *SADR_MBHF* of the message buffer header field must be 16-bit aligned.

22.6.2.1.1 Frame Header

The frame header occupies the first six bytes in the message buffer header field. It contains all FlexRay frame header related information according to the *FlexRay Communications System Protocol*

Specification, Version 2.1 Rev A. A detailed description of the usage and the content of the frame header is provided in [Section 22.6.5.2.1, Frame Header Description](#).

22.6.2.1.2 Data Field Offset

The data field offset follows the frame header in the message buffer data field and occupies two bytes. It contains the offset of the corresponding message buffer data field with respect to the controller flexray memory base address as provided by SMBA field in the [System Memory Base Address Register \(SYMBADR\)](#). The data field offset is used to determine the start address *SADR_MBDF* of the corresponding message buffer data field in the flexray memory according to [Equation 22-2](#).

$$\text{SADR_MBDF} = [\text{Data Field Offset}] + \text{SMBA} \quad \text{Eqn. 22-2}$$

22.6.2.1.3 Slot Status

The slot status occupies the last two bytes of the message buffer header field. It provides the slot and frame status related information according to the *FlexRay Communications System Protocol Specification, Version 2.1 Rev A*. A detailed description of the content and usage of the slot status is provided in [Section 22.6.5.2.3, Slot Status Description](#).

22.6.2.2 Message Buffer Data Field

The message buffer data field is a contiguous area of 2-byte entities. This field contains the frame payload data, or a part of it, of the frame to be transmitted to or received from the FlexRay bus. The minimum length of this field depends on the specific message buffer configuration and is specified in the message buffer descriptions given in [Section 22.6.3, Message Buffer Types](#).

22.6.3 Message Buffer Types

The controller provides three different types of message buffers.

- Individual Message Buffers
- Receive Shadow Buffers
- Receive FIFO Buffers

For each message buffer type the structure of the physical message buffer is identical. The message buffer types differ only in the structure and content of message buffer control data, which control the related physical message buffer. The message buffer control data are described in the following sections.

22.6.3.1 Individual Message Buffers

The individual message buffers are used for all types of frame transmission and for dedicated frame reception based on individual filter settings for each message buffer. The controller supports three types of individual message buffers, which are described in [Section 22.6.6, Individual Message Buffer Functional Description](#).

Each individual message buffer consists of two parts, the physical message buffer, which is located in the flexray memory, and the message buffer control data, which are located in dedicated registers. The structure of an individual message buffer is given in [Figure 22-104](#).

Each individual message buffer has a message buffer number n assigned, which determines the set of message buffer control registers associated to this individual message buffer. The individual message buffer with message buffer number n is controlled by the registers MBCCSR $_n$, MBCCFR $_n$, MBFIDR $_n$, and MBIDXR $_n$.

The connection between the message buffer control registers and the physical message buffer is established by the message buffer index field MBIDX in the [Message Buffer Index Registers \(MBIDXR \$_n\$ \)](#). The start address SADR_MBHF of the related message buffer header field in the flexray memory is determined according to [Equation 22-3](#).

$$\text{SADR_MBHF} = (\text{MBIDXR}_n[\text{MBIDX}] * 10) + \text{SMBA} \tag{Eqn. 22-3}$$

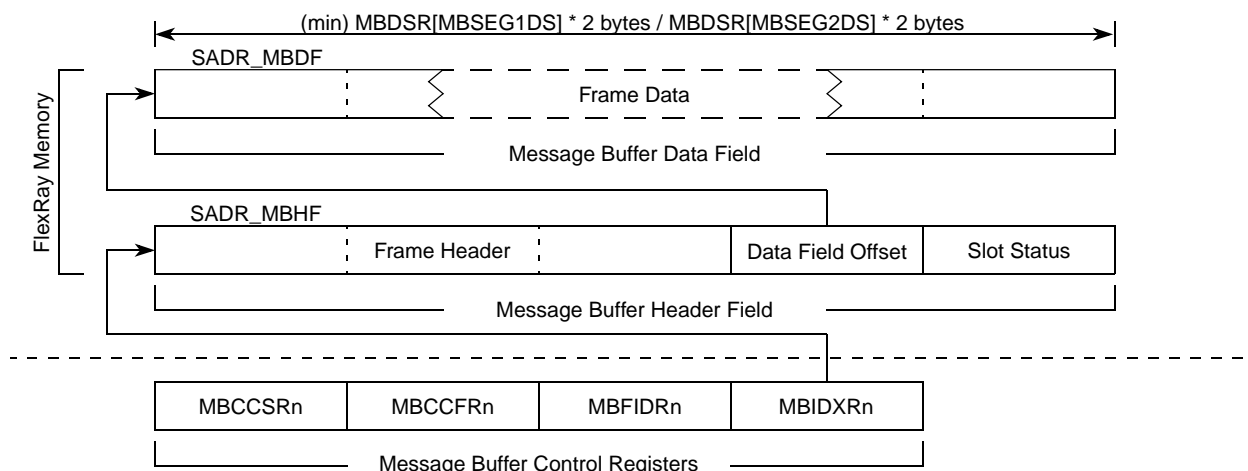

Figure 22-104. Individual Message Buffer Structure

22.6.3.1.1 Individual Message Buffer Segments

The set of the individual message buffers can be split up into two message buffer segments using the [Message Buffer Segment Size and Utilization Register \(MBSSUTR\)](#). All individual message buffers with a message buffer number $n \leq \text{MBSSUTR}[\text{LAST_MB_SEG1}]$ belong to the first message buffer segment. All individual message buffers with a message buffer number $n > \text{MBSSUTR}[\text{LAST_MB_SEG1}]$ belong to the second message buffer segment. The following rules apply to the length of the message buffer data field:

- all physical message buffers associated to individual message buffers that belong to the same message buffer segment must have message buffer data fields of the same length
- the minimum length of the message buffer data field for individual message buffers in the first message buffer segment is $2 * \text{MBDSR}[\text{MBSEG1DS}]$ bytes
- the minimum length of the message buffer data field for individual message buffers assigned to the second segment is $2 * \text{MBDSR}[\text{MBSEG2DS}]$ bytes.

22.6.3.2 Receive Shadow Buffers

The receive shadow buffers are required for the frame reception process for individual message buffers. The controller provides four receive shadow buffers, one receive shadow buffer per channel and per message buffer segment.

Each receive shadow buffer consists of two parts, the physical message buffer located in the flexray memory and the receive shadow buffer control registers located in dedicated registers. The structure of a receive shadow buffer is shown in Figure 22-105. The four internal shadow buffer control registers can be accessed by the [Receive Shadow Buffer Index Register \(RSBIR\)](#).

The connection between the receive shadow buffer control register and the physical message buffer for the selected receive shadow buffer is established by the receive shadow buffer index field RSBIDX in the [Receive Shadow Buffer Index Register \(RSBIR\)](#). The start address SADR_MBHF of the related message buffer header field in the flexray memory is determined according to [Equation 22-4](#).

$$\text{SADR_MBHF} = (\text{RSBIR}[\text{RSBIDX}] * 10) + \text{SMBA} \quad \text{Eqn. 22-4}$$

The length required for the message buffer data field depends on the message buffer segment that the receive shadow buffer is assigned to. For the receive shadow buffers assigned to the first message buffer segment, the length must be the same as for the individual message buffers assigned to the first message buffer segment. For the receive shadow buffers assigned to the second message buffer segment, the length must be the same as for the individual message buffers assigned to the second message buffer segment. The receive shadow buffer assignment is described in [Receive Shadow Buffer Index Register \(RSBIR\)](#).

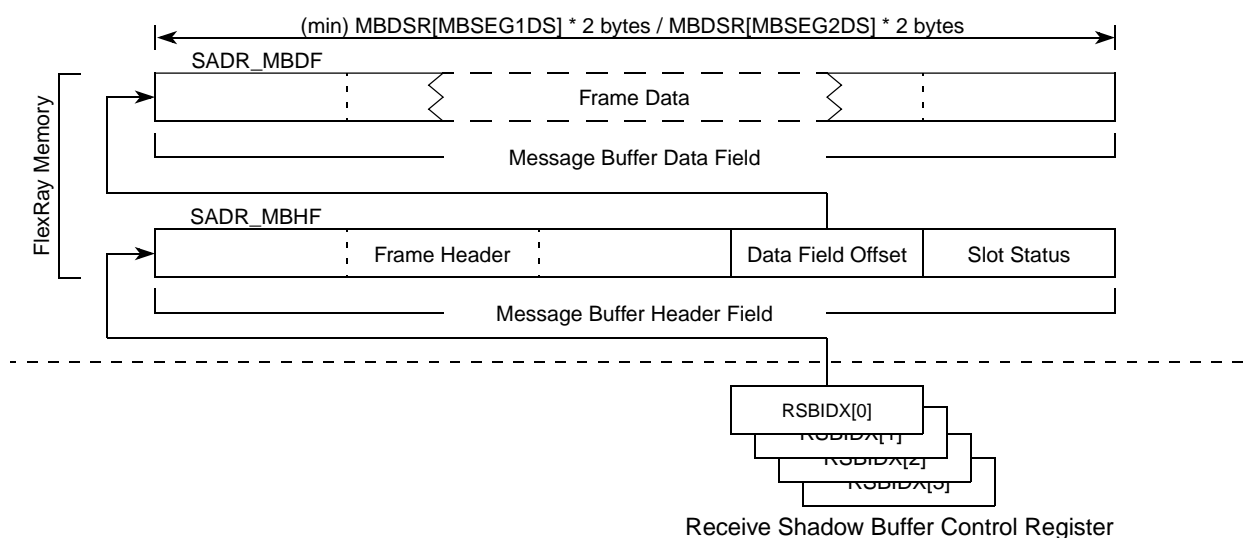

Figure 22-105. Receive Shadow Buffer Structure

22.6.3.3 Receive FIFO

The receive FIFO implements a frame reception system based on the FIFO concept. The controller provides two independent receive FIFOs, one per channel.

A receive FIFO consists of a set of physical message buffers in the flexray memory and a set of receive FIFO control registers located in dedicated registers. The structure of a receive FIFO is given in [Figure 22-106](#).

The connection between the receive FIFO control registers and the set of physical message buffers is established by the [Receive FIFO Start Index Register \(RFSIR\)](#), the [Receive FIFO Depth and Size Register \(RFDSR\)](#), and the [Receive FIFO A Read Index Register \(RFARIR\) / Receive FIFO B Read Index Register \(RFBRIR\)](#). The system memory base address SMBA is defined by the system memory base address register selected by the FIFO address mode bit MCR[FAM].

The start byte address SADR_MBHF[1] of the first message buffer header field that belongs to the receive FIFO in the flexray memory is determined according to [Equation 22-5](#).

$$\text{SADR_MBHF}[1] = (10 * \text{RFSIR}[\text{SIDX}]) + \text{SMBA} \quad \text{Eqn. 22-5}$$

The start byte address SADR_MBHF[n] of the last message buffer header field that belongs to the receive FIFO in the flexray memory is determined according to [Equation 22-6](#).

$$\text{SADR_MBHF}[n] = (10 * (\text{RFSIR}[\text{SIDX}] + \text{RFDSR}[\text{FIFO_DEPTH}])) + \text{SMBA} \quad \text{Eqn. 22-6}$$

NOTE

All message buffer header fields assigned to a receive FIFO must be a contiguous region.

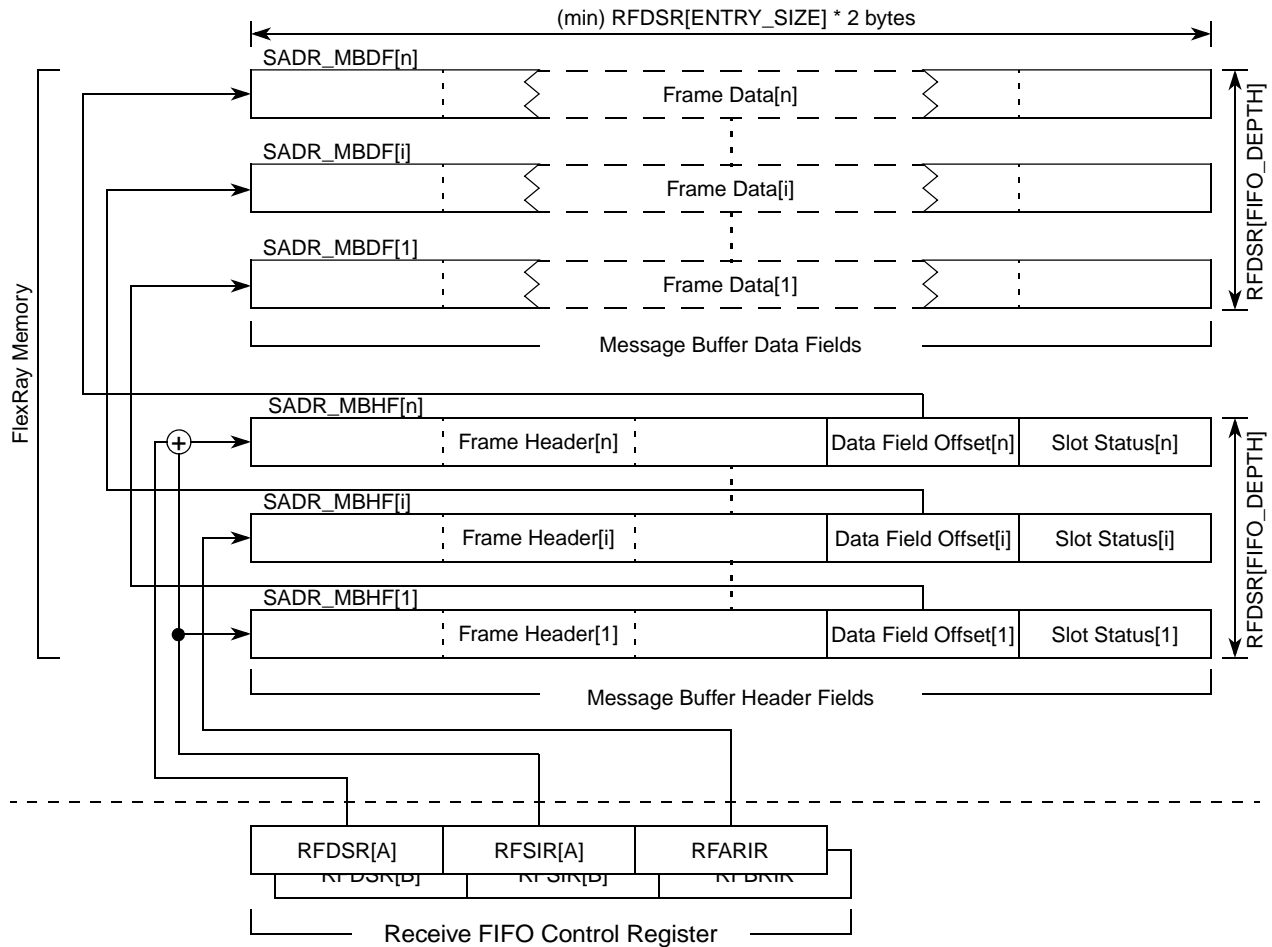

Figure 22-106. Receive FIFO Structure

22.6.3.4 Message Buffer Configuration and Control Data

This section describes the configuration and control data for each message buffer type.

22.6.3.4.1 Individual Message Buffer Configuration Data

Before an individual message buffer can be used for transmission or reception, it must be configured. There is a set of common configuration parameters that applies to all individual message buffers and a set of configuration parameters that applies to each message buffer individually.

Common Configuration Data

The set of common configuration data for individual message buffers is located in the following registers.

- [Message Buffer Data Size Register \(MBDSR\)](#)
The MBSEG2DS and MBSEG1DS fields define the minimum length of the message buffer data field with respect to the message buffer segment.
- [Message Buffer Segment Size and Utilization Register \(MBSSUTR\)](#)
The LAST_MB_SEG1 and LAST_MB_UTIL fields define the segmentation of the individual

message buffers and the number of individual message buffers that are used. For more details, see [Section 22.6.3.1.1, Individual Message Buffer Segments](#).

Specific Configuration Data

The set of message buffer specific configuration data for individual message buffers is located in the following registers.

- [Message Buffer Configuration, Control, Status Registers \(MBCCSRn\)](#)
The MCM, MBT, MTD bits configure the message buffer type.
- [Message Buffer Cycle Counter Filter Registers \(MBCCFRn\)](#)
The MTM, CHA, CHB bits configure the transmission mode and the channel assignment. The CCFE, CCFMSK, and CCFVAL bits and fields configure the cycle counter filter.
- [Message Buffer Frame ID Registers \(MBFIDRn\)](#)
For a transmit message buffer, the FID field is used to determine the slot in which the message in this message buffer will be transmitted.
- [Message Buffer Index Registers \(MBIDXRn\)](#)
This MBIDX field provides the index of the message buffer header field of the physical message buffer that is currently associated with this message buffer.

22.6.3.5 Individual Message Buffer Control Data

During normal operation, each individual message buffer can be controlled by the control and trigger bits CMT, LCKT, EDT, and MBIE in the [Message Buffer Configuration, Control, Status Registers \(MBCCSRn\)](#).

22.6.3.6 Receive Shadow Buffer Configuration Data

Before frame reception into the individual message buffers can be performed, the receive shadow buffers must be configured. The configuration data are provided by the [Receive Shadow Buffer Index Register \(RSBIR\)](#). For each receive shadow buffer, the application provides the message buffer header index. When the protocol is in the *POC:normal active* or *POC:normal passive* state, the receive shadow buffers are under full controller control.

22.6.3.7 Receive FIFO Control and Configuration Data

This section describes the configuration and control data for the two receive FIFOs.

22.6.3.7.1 Receive FIFO Configuration Data

The controller provides two functional independent receive FIFOs, one per channel. The FIFOs have a common subset of configuration data:

- [Receive FIFO System Memory Base Address Register \(RFSYMBADR\)](#)
- [Receive FIFO Periodic Timer Register \(RFPTR\)](#)

Each FIFO has its own set of configuration data. The configuration data are located in the following registers:

- Receive FIFO Watermark and Selection Register (RFWMSR)
- Receive FIFO Start Index Register (RFSIR)
- Receive FIFO Depth and Size Register (RFDSR)
- Receive FIFO Message ID Acceptance Filter Value Register (RFMIDAFVR)
- Receive FIFO Message ID Acceptance Filter Mask Register (RFMIAFMR)
- Receive FIFO Frame ID Rejection Filter Value Register (RFFIDRFVR)
- Receive FIFO Frame ID Rejection Filter Mask Register (RFFIDRFMR)
- Receive FIFO Range Filter Configuration Register (RFRFCFR)

22.6.3.7.2 Receive FIFO Control Data

The application can access the FIFOs at any time using the control bits in the following registers:

- Global Interrupt Flag and Enable Register (GIFER)
- Receive FIFO Fill Level and POP Count Register (RFFLPCR)

22.6.3.7.3 Receive FIFO Status Data

The current status of the receive fifo is provided in the following register:

- Global Interrupt Flag and Enable Register (GIFER)
- Receive FIFO A Read Index Register (RFARIR)
- Receive FIFO B Read Index Register (RFBRIR)
- Receive FIFO Fill Level and POP Count Register (RFFLPCR)

22.6.4 FlexRay Memory Layout

The controller supports a wide range of possible layouts for the flexray memory. Two basic layout modes can be selected by the FIFO address mode bit MCR[FAM].

22.6.4.1 FlexRay Memory Layout (MCR[FAM] = 0)

Figure 22-107 shows an example layout for the FIFO address mode MCR[FAM]=0. In this mode, the following set of rules applies to the layout of the flexray memory:

- The flexray memory is one contiguous region.
- The flexray memory size is maximum 64 Kbytes.
- The flexray memory starts at a 16 byte boundary

The flexray memory contains three areas: the *message buffer header area*, the *message buffer data area*, and the *sync frame table area*.

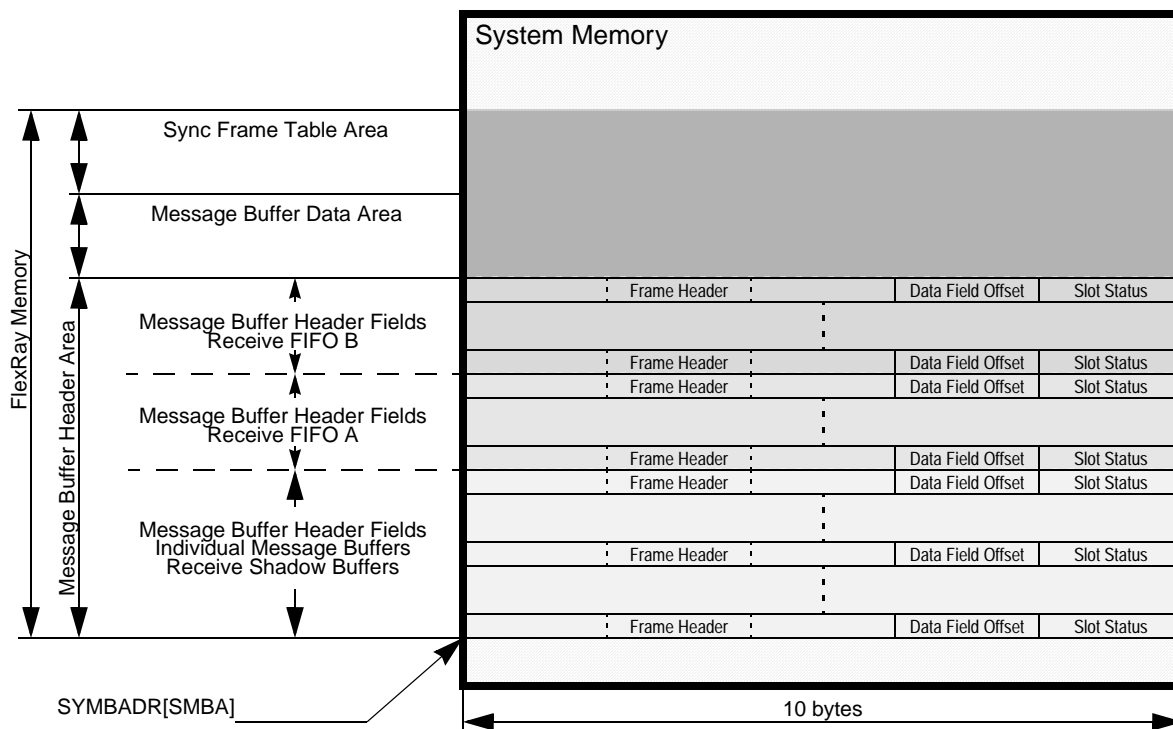

Figure 22-107. Example of FlexRay Memory Layout (MCR[FAM] = 0)

22.6.4.2 FlexRay Memory Layout (MCR[FAM] = 1)

Figure 22-108 shows an example layout for the FIFO address mode MCR[FAM]=1. The following set of rules applies to the layout of the flexray memory:

- The flexray memory consists of two contiguous regions.
- The size of each region is maximum 64 Kbytes.
- Each region start at a 16 byte boundary.

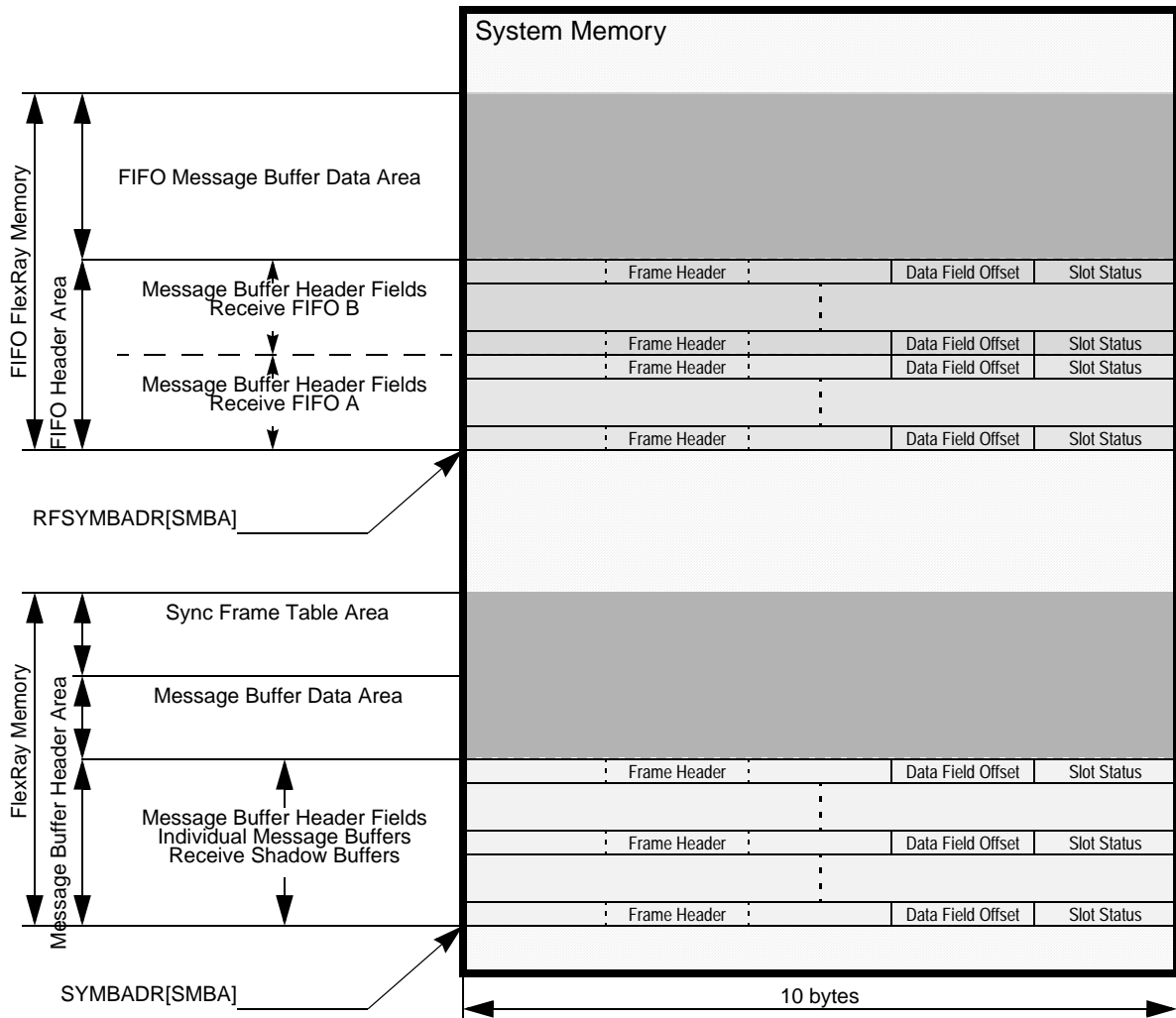

Figure 22-108. Example of FlexRay Memory Layout (MCR[FAM] = 1)

22.6.4.3 Message Buffer Header Area (MCR[FAM] = 0)

The message buffer header area contains all message buffer header fields of the physical message buffers for all message buffer types. The following rules apply to the message buffer header fields for the three type of message buffers.

1. The start byte address SADR_MBHF of each message buffer header field for *individual message buffers* and *receive shadow buffers* must fulfill Equation 22-7.

$$\text{SADR_MBHF} = (i * 10) + \text{SYMBADR}[\text{SMBA}]; (0 \leq i < 256) \quad \text{Eqn. 22-7}$$

2. The start byte address SADR_MBHF of each message buffer header field for the *FIFO* must fulfill Equation 22-8.

$$\text{SADR_MBHF} = (i * 10) + \text{SYMDARD}[\text{SMBA}]; (0 \leq i < 1024) \quad \text{Eqn. 22-8}$$

$$\text{SADR_MBHF} = (i * 10) + \text{SYMBADR}[\text{SMBA}]; (0 \leq i < 1024) \quad \text{Eqn. 22-9}$$

- The message buffer header fields for each FIFO have to be a contiguous area.

22.6.4.4 Message Buffer Header Area (MCR[FAM] = 1)

The message buffer header area contains all message buffer header fields of the physical message buffers for the individual message buffers and receiver shadow buffers. The following rules apply to the message buffer header fields for the two type of message buffers.

- The start address SADR_MBHF of each message buffer header field for *individual message buffers* and *receive shadow buffers* must fulfill [Equation 22-10](#).

$$\text{SADR_MBHF} = (i * 10) + \text{SYMBADR}[\text{SMBA}]; (0 \leq i < 256) \quad \text{Eqn. 22-10}$$

22.6.4.5 FIFO Message Buffer Header Area (MCR[FAM] = 1)

The FIFO message buffer header area contains all message buffer header fields of the physical message buffers for the FIFO. The following rules apply to the FIFO message buffer header fields.

- The start byte address SADR_MBHF of each message buffer header field for the *FIFO* must fulfill [Equation 22-11](#).

$$\text{SADR_MBHF} = (i * 10) + \text{RFSYMBADR}[\text{SMBA}]; (0 \leq i < 1024) \quad \text{Eqn. 22-11}$$

- The message buffer header fields for each FIFO have to be a contiguous area.

22.6.4.6 Message Buffer Data Area

The message buffer data area contains all the message buffer data fields of the physical message buffers. Each message buffer data field must start at a 16-bit boundary.

22.6.4.7 Sync Frame Table Area

The sync frame table area is used to provide a copy of the internal sync frame tables for application access. Refer to [Section 22.6.12, Sync Frame ID and Sync Frame Deviation Tables](#), for the description of the sync frame table area.

22.6.5 Physical Message Buffer Description

This section provides a detailed description of the usage and the content of the two parts of a physical message buffer, the message buffer header field and the message buffer data field.

22.6.5.1 Message Buffer Protection and Data Consistency

The physical message buffers are located in the flexray memory. The controller provides no means to protect the flexray memory from uncontrolled or illegal host or other client write access. To ensure data consistency of the physical message buffers, the application must follow the write access scheme that is given in the description of each of the physical message buffer fields.

22.6.5.2 Message Buffer Header Field Description

This section provides a detailed description of the usage and content of the message buffer header field. A description of the structure of the message buffer header fields is given in [Section 22.6.2.1, Message Buffer Header Field](#). Each message buffer header field consists of three sections: the frame header section, the data field offset, and the slot status section. For a detailed description of the Data Field Offset, see [Section 22.6.2.1.2, Data Field Offset](#).

22.6.5.2.1 Frame Header Description

Frame Header Content

The semantic and content of the frame header section depends on the message buffer type.

For individual receive message buffers and receive FIFOs, the frame header receives the frame header data of the *first valid frame* received on the assigned channels.

For receive shadow buffers, the frame header receives the frame header data of the current frame received regardless of whether the frame is valid or not.

For transmit message buffers, the application writes the frame header of the frame to be transmitted into this location. The frame header will be read out when the frame is transferred to the FlexRay bus.

The structure of the frame header in the message buffer header field for receive message buffers and the receive FIFO is given in [Figure 22-109](#). A detailed description is given in [Table 22-85](#).

| | | | | | | | | | | | | | | | | |
|-----|---|-----|--------|-----|-----|-------|---|--------|---|---|----|----|----|----|----|----|
| | 0 | 1 | 2 | 3 | 4 | 5 | 6 | 7 | 8 | 9 | 10 | 11 | 12 | 13 | 14 | 15 |
| 0x0 | R | PPI | NUF | SYF | SUF | FID | | | | | | | | | | |
| 0x2 | 0 | 0 | CYCCNT | | | | 0 | PLDLEN | | | | | | | | |
| 0x4 | 0 | 0 | 0 | 0 | 0 | HDCRC | | | | | | | | | | |

Figure 22-109. Frame Header Structure (Receive Message Buffer and Receive FIFO)

The structure of the frame header in the message buffer header field for transmit message buffers is given in [Figure 22-110](#). A detailed description is given in [Table 22-86](#). The checks that will be performed are described in [Frame Header Checks](#).

| | | | | | | | | | | | | | | | | |
|-----|---|-----|--------|-----|-----|-------|---|--------|---|---|----|----|----|----|----|----|
| | 0 | 1 | 2 | 3 | 4 | 5 | 6 | 7 | 8 | 9 | 10 | 11 | 12 | 13 | 14 | 15 |
| 0x0 | R | PPI | NUF | SYF | SUF | FID | | | | | | | | | | |
| 0x2 | | | CYCCNT | | | | | PLDLEN | | | | | | | | |
| 0x4 | | | | | | HDCRC | | | | | | | | | | |

= not used
 = checked
 = checked if static slot

Figure 22-110. Frame Header Structure (Transmit Message Buffer)

The structure of the frame header in the message buffer header field for transmit message buffers assigned to key slot is given in [Figure 22-111](#).

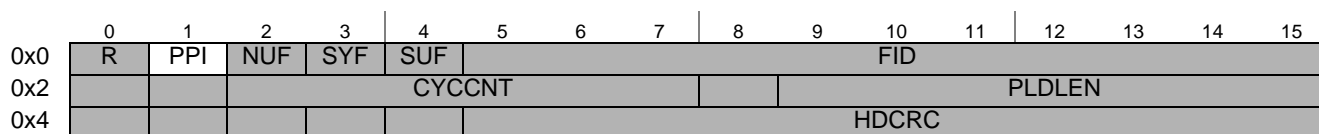

= not used

Figure 22-111. Frame Header Structure (Transmit Message Buffer for Key Slot)

Frame Header Access

The frame header is located in the flexray memory. To ensure data consistency, the application must follow the write access scheme described below.

For receive message buffers, receive shadow buffers, and receive FIFOs, the application must not write to the frame header field.

For transmit message buffers, the application must follow the write access restrictions given in [Table 22-84](#). This table shows the condition under which the application can write to the frame header entries without corrupting the FlexRay message transmission.

Table 22-84. Frame Header Write Access Constraints (Transmit Message Buffer)

| Field | Single Buffered | | Double Buffered | | | |
|--------------------|-----------------------------|-----------------|-----------------|---------------|-----------------|---------------|
| | Static Segment | Dynamic Segment | Static Segment | | Dynamic Segment | |
| | | | Commit Side | Transmit Side | Commit Side | Transmit Side |
| FID | <i>POC:config</i> or MB_DIS | | | | | |
| PPI, PLDLEN, HDCRC | | MB_LCK | | | MB_LCK | |

Frame Header Checks

As shown in [Figure 22-110](#) and [Figure 22-111](#) not all fields in the message buffer frame header are used for transmission. Some fields in the message buffer frame header are ignored, some are used for transmission, and some of them are checked for correct values. All checks that will be performed are described below.

For message buffers assigned to the key slot, no checks will be performed.

The value of the FID field must be equal to the value of the corresponding [Message Buffer Frame ID Registers \(MBFIDRn\)](#). If the controller detects a mismatch while transmitting the frame header, it will set the frame ID error flag FID_EF in the [CHI Error Flag Register \(CHIERFR\)](#). The value of the FID field will be ignored and replaced by the value provided in the [Message Buffer Frame ID Registers \(MBFIDRn\)](#).

For transmit message buffers assigned to the *static* segment, the PLDLEN value must be equal to the value of the payload_length_static field in the [Protocol Configuration Register 19 \(PCR19\)](#). If this is not fulfilled, the static payload length error flag SPL_EF in the [CHI Error Flag Register \(CHIERFR\)](#) is set when the message buffer is under transmission. A syntactically and semantically correct frame is generated with payload_length_static payload words and the payload length field in the transmitted frame header set to payload_length_static.

For transmit message buffers assigned to the *dynamic* segment, the PLDLEN value must be less than or equal to the value of the `max_payload_length_dynamic` field in the [Protocol Configuration Register 24 \(PCR24\)](#). If this is not fulfilled, the dynamic payload length error flag `DPL_EF` in the [CHI Error Flag Register \(CHIERFR\)](#) is set when the message buffer is under transmission. A syntactically and semantically correct dynamic frame is generated with PLDLEN payload words and the payload length field in the frame header set to PLDLEN.

Table 22-85. Frame Header Field Descriptions (Receive Message Buffer and Receive FFO)

| Field | Description |
|--------|---|
| R | Reserved Bit — This is the value of the Reserved bit of the received frame stored in the message buffer |
| PPI | Payload Preamble Indicator — This is the value of the Payload Preamble Indicator of the received frame stored in the message buffer. |
| NUF | Null Frame Indicator — This is the value of the Null Frame Indicator of the received frame stored in the message buffer. |
| SYF | Sync Frame Indicator — This is the value of the Sync Frame Indicator of the received frame stored in the message buffer. |
| SUF | Startup Frame Indicator — This is the value of the Startup Frame Indicator of the received frame stored in the message buffer. |
| FID | Frame ID — This is the value of the Frame ID field of the received frame stored in the message buffer. |
| CYCCNT | Cycle Count — This is the number of the communication cycle in which the frame stored in the message buffer was received. |
| PLDLEN | Payload Length — This is the value of the Payload Length field of the received frame stored in the message buffer. |
| HDCRC | Header CRC — This is the value of the Header CRC field of the received frame stored in the message buffer. |

Table 22-86. Frame Header Field Descriptions (Transmit Message Buffer)

| Field | Description |
|--------|---|
| R | Reserved Bit — This bit is not used, the value of the Reserved bit is generated internally according to <i>FlexRay Communications System Protocol Specification, Version 2.1 Rev A</i> . |
| PPI | Payload Preamble Indicator — This bit provides the value of the Payload Preamble Indicator for the frame transmitted from the message buffer. |
| NUF | Null Frame Indicator — This bit is not used, the value of the Null Frame Indicator is generated internally according to <i>FlexRay Communications System Protocol Specification, Version 2.1 Rev A</i> . |
| SYF | Sync Frame Indicator — This bit is not used, the value of the Sync Frame Indicator is generated internally according to <i>FlexRay Communications System Protocol Specification, Version 2.1 Rev A</i> . |
| SUF | Startup Frame Indicator — This bit is not used, the value of the Startup Frame Indicator is generated internally according to <i>FlexRay Communications System Protocol Specification, Version 2.1 Rev A</i> . |
| FID | Frame ID — This field is checked as described in Frame Header Checks . |
| CYCCNT | Cycle Count — This field is not used, the value of the transmitted Cycle Count field is taken from the internal communication cycle counter. |

Table 22-86. Frame Header Field Descriptions (Transmit Message Buffer) (continued)

| Field | Description |
|--------|--|
| PLDLEN | Payload Length — This field is checked and used as described in Frame Header Checks . |
| HDCRC | Header CRC — This field provides the value of the Header CRC field for the frame transmitted from the message buffer. |

22.6.5.2.2 Data Field Offset Description

Data Field Offset Content

For a detailed description of the Data Field Offset, see [Section 22.6.2.1.2, Data Field Offset](#).

Data Field Offset Access

The application shall program the Data Field Offset when configuring the message buffers either in the *POC:config* state or when the message buffer is disabled.

22.6.5.2.3 Slot Status Description

The slot status is a read-only structure for the application and a write-only structure for the controller. The meaning and content of the slot status in the message buffer header field depends on the message buffer type.

Receive Message Buffer and Receive FIFO Slot Status Description

This section describes the slot status structure for the individual receive message buffers and receive FIFOs. The content of the slot status structure for receive message buffers depends on the message buffer type and on the channel assignment for individual receive message buffers as given by [Table 22-87](#).

Table 22-87. Receive Message Buffer Slot Status Content

| Receive Message Buffer Type | Slot Status Content |
|--|-----------------------------------|
| Individual Receive Message Buffer assigned to both channels MBCCSRn[CHA]=1 and MBCCSRn[CHB]=1 | see Figure 22-112 |
| Individual Receive Message Buffer assigned to channel A MBCCSRn[CHA]=1 and MBCCSRn[CHB]=0 | see Figure 22-113 |
| Individual Receive Message Buffer assigned to channel B MBCCSRn[CHA]=0 and MBCCSRn[CHB]=1 | see Figure 22-114 |
| Receive FIFO Channel A Message Buffer | see Figure 22-113 |
| Receive FIFO Channel B Message Buffer | see Figure 22-114 |

The meaning of the bits in the slot status structure is explained in [Table 22-88](#).

| | | | | | | | | | | | | | | | | |
|-------|-----|-----|-----|-----|-----|-----|-----|----|-----|-----|-----|-----|-----|-----|-----|----|
| | 0 | 1 | 2 | 3 | 4 | 5 | 6 | 7 | 8 | 9 | 10 | 11 | 12 | 13 | 14 | 15 |
| R | VFB | SYB | NFB | SUB | SEB | CEB | BVB | CH | VFA | SYA | NFA | SUA | SEA | CEA | BVA | 0 |
| Reset | - | - | - | - | - | - | - | - | - | - | - | - | - | - | - | - |

Figure 22-112. Receive Message Buffer Slot Status Structure (ChAB)

| | | | | | | | | | | | | | | | | |
|-------|---|---|---|---|---|---|---|---|-----|-----|-----|-----|-----|-----|-----|----|
| | 0 | 1 | 2 | 3 | 4 | 5 | 6 | 7 | 8 | 9 | 10 | 11 | 12 | 13 | 14 | 15 |
| R | 0 | 0 | 0 | 0 | 0 | 0 | 0 | 0 | VFA | SYA | NFA | SUA | SEA | CEA | BVA | 0 |
| Reset | - | - | - | - | - | - | - | - | - | - | - | - | - | - | - | - |

Figure 22-113. Receive Message Buffer Slot Status Structure (ChA)

| | | | | | | | | | | | | | | | | |
|-------|-----|-----|-----|-----|-----|-----|-----|---|---|---|----|----|----|----|----|----|
| | 0 | 1 | 2 | 3 | 4 | 5 | 6 | 7 | 8 | 9 | 10 | 11 | 12 | 13 | 14 | 15 |
| R | VFB | SYB | NFB | SUB | SEB | CEB | BVB | 1 | 0 | 0 | 0 | 0 | 0 | 0 | 0 | 0 |
| Reset | - | - | - | - | - | - | - | - | - | - | - | - | - | - | - | - |

Figure 22-114. Receive Message Buffer Slot Status Structure (ChB)
Table 22-88. Receive Message Buffer Slot Status Field Descriptions

| Field | Description |
|--|--|
| Common Message Buffer Status Bits | |
| VFB | Valid Frame on Channel B — protocol related variable: <i>vSS!ValidFrame</i> channel B 0 <i>vSS!ValidFrame</i> = 0 1 <i>vSS!ValidFrame</i> = 1 |
| SYB | Sync Frame Indicator Channel B — protocol related variable: <i>vRF!Header!SyFIndicator</i> channel B 0 <i>vRF!Header!SyFIndicator</i> = 0 1 <i>vRF!Header!SyFIndicator</i> = 1 |
| NFB | Null Frame Indicator Channel B — protocol related variable: <i>vRF!Header!NFIndicator</i> channel B 0 <i>vRF!Header!NFIndicator</i> = 0 1 <i>vRF!Header!NFIndicator</i> = 1 |
| SUB | Startup Frame Indicator Channel B — protocol related variable: <i>vRF!Header!SuFIndicator</i> channel B 0 <i>vRF!Header!SuFIndicator</i> = 0 1 <i>vRF!Header!SuFIndicator</i> = 1 |
| SEB | Syntax Error on Channel B — protocol related variable: <i>vSS!SyntaxError</i> channel B 0 <i>vSS!SyntaxError</i> = 0 1 <i>vSS!SyntaxError</i> = 1 |
| CEB | Content Error on Channel B — protocol related variable: <i>vSS!ContentError</i> channel B 0 <i>vSS!ContentError</i> = 0 1 <i>vSS!ContentError</i> = 1 |
| BVB | Boundary Violation on Channel B — protocol related variable: <i>vSS!BViolation</i> channel B 0 <i>vSS!BViolation</i> = 0 1 <i>vSS!BViolation</i> = 1 |
| CH | Channel first valid received — This status bit applies only to receive message buffers assigned to the static segment and to both channels. It indicates the channel that has received the <i>first valid</i> frame in the slot. This flag is set to 0 if no valid frame was received at all in the subscribed slot. 0 first valid frame received on channel A, or no valid frame received at all 0 first valid frame received on channel B |
| VFA | Valid Frame on Channel A — protocol related variable: <i>vSS!ValidFrame</i> channel A 0 <i>vSS!ValidFrame</i> = 0 1 <i>vSS!ValidFrame</i> = 1 |

Table 22-88. Receive Message Buffer Slot Status Field Descriptions (continued)

| Field | Description |
|-------|--|
| SYA | Sync Frame Indicator Channel A — protocol related variable: <i>vRF!Header!SyFIndicator</i> channel A 0 <i>vRF!Header!SyFIndicator</i> = 0 1 <i>vRF!Header!SyFIndicator</i> = 1 |
| NFA | Null Frame Indicator Channel A — protocol related variable: <i>vRF!Header!NFIndicator</i> channel A 0 <i>vRF!Header!NFIndicator</i> = 0 1 <i>vRF!Header!NFIndicator</i> = 1 |
| SUA | Startup Frame Indicator Channel A — protocol related variable: <i>vRF!Header!SuFIndicator</i> channel A 0 <i>vRF!Header!SuFIndicator</i> = 0 1 <i>vRF!Header!SuFIndicator</i> = 1 |
| SEA | Syntax Error on Channel A — protocol related variable: <i>vSS!SyntaxError</i> channel A 0 <i>vSS!SyntaxError</i> = 0 1 <i>vSS!SyntaxError</i> = 1 |
| CEA | Content Error on Channel A — protocol related variable: <i>vSS!ContentError</i> channel A 0 <i>vSS!ContentError</i> = 0 1 <i>vSS!ContentError</i> = 1 |
| BVA | Boundary Violation on Channel A — protocol related variable: <i>vSS!BViolation</i> channel A 0 <i>vSS!BViolation</i> = 0 1 <i>vSS!BViolation</i> = 1 |

Transmit Message Buffer Slot Status Description

This section describes the slot status structure for transmit message buffers. Only the TCA and TCB status bits are directly related to the transmission process. All other status bits in this structure are related to a receive process that may have occurred. The content of the slot status structure for transmit message buffers depends on the channel assignment as given by [Table 22-89](#).

Table 22-89. Transmit Message Buffer Slot Status Content

| Transmit Message Buffer Type | Slot Status Content |
|---|-----------------------------------|
| Individual Transmit Message Buffer assigned to both channels MBCCSRn[CHA]=1 and MBCCSRn[CHB]=1 | see Figure 22-115 |
| Individual Transmit Message Buffer assigned to channel A MBCCSRn[CHA]=1 and MBCCSRn[CHB]=0 | see Figure 22-116 |
| Individual Transmit Message Buffer assigned to channel B MBCCSRn[CHA]=0 and MBCCSRn[CHB]=1 | see Figure 22-117 |

The meaning of the bits in the slot status structure is described in [Table 22-88](#).

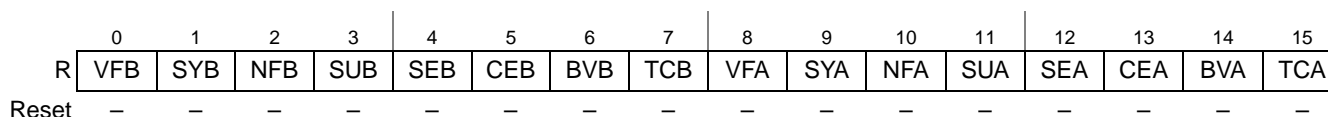
Figure 22-115. Transmit Message Buffer Slot Status Structure (ChAB)

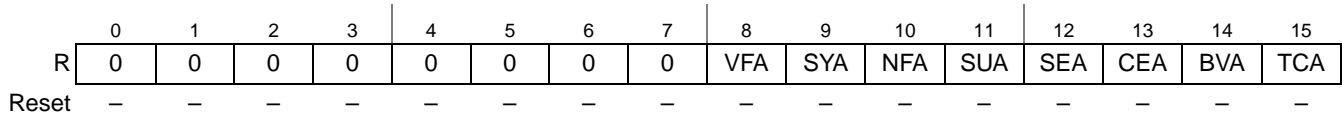
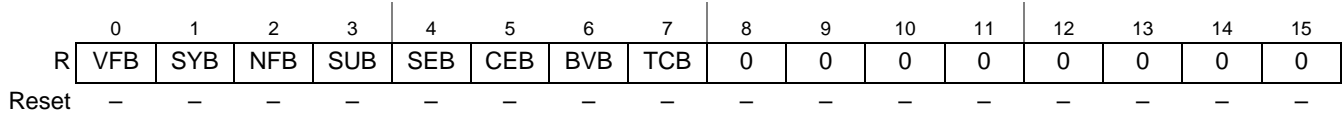
Figure 22-116. Transmit Message Buffer Slot Status Structure (ChA)

Figure 22-117. Transmit Message Buffer Slot Status Structure (ChB)
Table 22-90. Transmit Message Buffer Slot Status Structure Field Descriptions

| Field | Description |
|-------|--|
| VFB | Valid Frame on Channel B — protocol related variable: <i>vSS!ValidFrame</i> channel B 0 <i>vSS!ValidFrame</i> = 0 1 <i>vSS!ValidFrame</i> = 1 |
| SYB | Sync Frame Indicator Channel B — protocol related variable: <i>vRF!Header!SyFIndicator</i> channel B 0 <i>vRF!Header!SyFIndicator</i> = 0 1 <i>vRF!Header!SyFIndicator</i> = 1 |
| NFB | Null Frame Indicator Channel B — protocol related variable: <i>vRF!Header!NFIndicator</i> channel B 0 <i>vRF!Header!NFIndicator</i> = 0 1 <i>vRF!Header!NFIndicator</i> = 1 |
| SUB | Startup Frame Indicator Channel B — protocol related variable: <i>vRF!Header!SuFIndicator</i> channel B 0 <i>vRF!Header!SuFIndicator</i> = 0 1 <i>vRF!Header!SuFIndicator</i> = 1 |
| SEB | Syntax Error on Channel B — protocol related variable: <i>vSS!SyntaxError</i> channel B 0 <i>vSS!SyntaxError</i> = 0 1 <i>vSS!SyntaxError</i> = 1 |
| CEB | Content Error on Channel B — protocol related variable: <i>vSS!ContentError</i> channel B 0 <i>vSS!ContentError</i> = 0 1 <i>vSS!ContentError</i> = 1 |
| BVB | Boundary Violation on Channel B — protocol related variable: <i>vSS!BViolation</i> channel B 0 <i>vSS!BViolation</i> = 0 1 <i>vSS!BViolation</i> = 1 |
| TCB | Transmission Conflict on Channel B — protocol related variable: <i>vSS!TxConflict</i> channel B 0 <i>vSS!TxConflict</i> = 0 1 <i>vSS!TxConflict</i> = 1 |
| VFA | Valid Frame on Channel A — protocol related variable: <i>vSS!ValidFrame</i> channel A 0 <i>vSS!ValidFrame</i> = 0 1 <i>vSS!ValidFrame</i> = 1 |
| SYA | Sync Frame Indicator Channel A — protocol related variable: <i>vRF!Header!SyFIndicator</i> channel A 0 <i>vRF!Header!SyFIndicator</i> = 0 1 <i>vRF!Header!SyFIndicator</i> = 1 |
| NFA | Null Frame Indicator Channel A — protocol related variable: <i>vRF!Header!NFIndicator</i> channel A 0 <i>vRF!Header!NFIndicator</i> = 0 1 <i>vRF!Header!NFIndicator</i> = 1 |
| SUA | Startup Frame Indicator Channel A — protocol related variable: <i>vRF!Header!SuFIndicator</i> channel A 0 <i>vRF!Header!SuFIndicator</i> = 0 1 <i>vRF!Header!SuFIndicator</i> = 1 |

Table 22-90. Transmit Message Buffer Slot Status Structure Field Descriptions (continued)

| Field | Description |
|-------|--|
| SEA | Syntax Error on Channel A — protocol related variable: <i>vSS!SyntaxError</i> channel A 0 <i>vSS!SyntaxError</i> = 0 1 <i>vSS!SyntaxError</i> = 1 |
| CEA | Content Error on Channel A — protocol related variable: <i>vSS!ContentError</i> channel A 0 <i>vSS!ContentError</i> = 0 1 <i>vSS!ContentError</i> = 1 |
| BVA | Boundary Violation on Channel A — protocol related variable: <i>vSS!BViolation</i> channel A 0 <i>vSS!BViolation</i> = 0 1 <i>vSS!BViolation</i> = 1 |
| TCA | Transmission Conflict on Channel A — protocol related variable: <i>vSS!TxConflict</i> channel A 0 <i>vSS!TxConflict</i> = 0 1 <i>vSS!TxConflict</i> = 1 |

22.6.5.3 Message Buffer Data Field Description

The message buffer data field is used to store the frame payload data, or a part of it, of the frame to be transmitted to or received from the FlexRay bus. The minimum required length of this field depends on the message buffer type that the physical message buffer is assigned to and is given in [Table 22-91](#). The structure of the message buffer data field is given in [Figure 22-118](#).

Table 22-91. Message Buffer Data Field Minimum Length

| physical message buffer assigned to | minimum length defined by |
|--|------------------------------------|
| Individual Message Buffer in Segment 1 | MBDSR[MBSEG1DS] |
| Receive Shadow Buffer in Segment 1 | MBDSR[MBSEG1DS] |
| Individual Message Buffer in Segment 2 | MBDSR[MBSEG2DS] |
| Receive Shadow Buffer in Segment 2 | MBDSR[MBSEG2DS] |
| Receive FIFO for channel A | RFDSR[ENTRY_SIZE] (RFDSR[SEL] = 0) |
| Receive FIFO for channel B | RFDSR[ENTRY_SIZE] (RFDSR[SEL] = 1) |

NOTE

The controller will not access any locations outside the message buffer data field boundaries given by [Table 22-91](#).

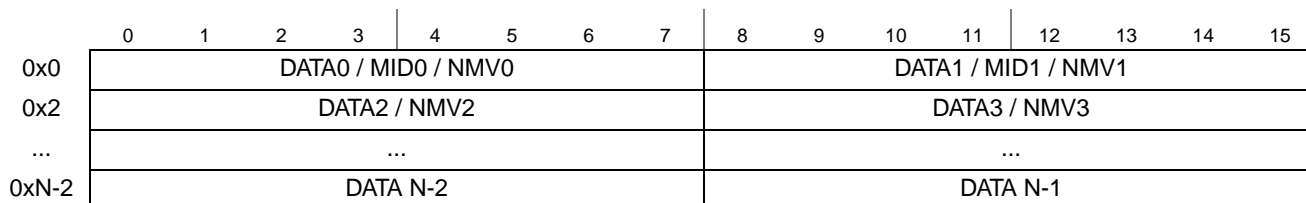
Figure 22-118. Message Buffer Data Field Structure

The message buffer data field is located in the flexray memory; thus, the controller has no means to control application write access to the field. To ensure data consistency, the application must follow a write and read access scheme.

22.6.5.3.1 Message Buffer Data Field Read Access

For transmit message buffers, the controller will not modify the content of the Message Buffer Data Field. Thus the application can read back the data at any time without any impact on data consistency.

For receive message buffers the application must lock the related receive message buffer and retrieve the message buffer header index from the [Message Buffer Index Registers \(MBIDXRn\)](#). While the message buffer is locked, the controller will not update the Message Buffer Data Field.

For receive FIFOs, the application can read the message buffer indicated by the [Receive FIFO A Read Index Register \(RFARIR\)](#) or the [Receive FIFO B Read Index Register \(RFBIRIR\)](#) when the related fill levels in the [Receive FIFO Fill Level and POP Count Register \(RFFLPCR\)](#) indicate a non-empty FIFO.

22.6.5.3.2 Message Buffer Data Field Write Access

For receive message buffers, receive shadow buffers, and receive FIFOs, the application must not write to the message buffer data field.

For transmit message buffers, the application must follow the write access restrictions given in [Table 22-92](#).

Table 22-92. Frame Data Write Access Constraints

| Field | single buffered | double buffered | |
|----------------|---------------------------------------|---------------------------------------|-----------------------------|
| | | commit side | transmit side |
| DATA, MID, NMV | <i>POC:config</i> or MB_DIS or MB_LCK | <i>POC:config</i> or MB_DIS or MB_LCK | <i>POC:config</i> or MB_DIS |

Table 22-93. Frame Data Field Descriptions

| Field | Description |
|---------------------------------------|--|
| DATA 0, DATA 1, ... DATA N-1 | Message Data — Provides the message data received or to be transmitted. For receive message buffer and receive FIFOs, this field provides the message data received for this message buffer. For transmit message buffers, the field provides the message data to be transmitted. |
| MID 0, MID 1 | Message Identifier — If the payload preamble bit PPI is set in the message buffer frame header, the MID field holds the message ID of a dynamic frame located in the message buffer. The receive FIFO filter uses the received message ID for message ID filtering. |
| NMV 0, NMV 1, ... NMV 11 | Network Management Vector — If the payload preamble bit PPI is set in the message buffer frame header, the network management vector field holds the network management vector of a static frame located in the message buffer. Note: The MID and NMV bytes replace the corresponding DATA bytes. |

22.6.6 Individual Message Buffer Functional Description

The controller provides three basic types of individual message buffers:

1. Single Transmit Message Buffers
2. Double Transmit Message Buffers
3. Receive Message Buffers

Before an individual message buffer can be used, it must be configured by the application. After the initial configuration, the message buffer can be reconfigured later. The set of the configuration data for individual message buffers is given in [Section 22.6.3.4.1, Individual Message Buffer Configuration Data](#).

22.6.6.1 Individual Message Buffer Configuration

The individual message buffer configuration consists of two steps. The first step is the allocation of the required amount of memory for the flexray memory. The second step is the programming of the message buffer configuration registers, which is described in this section.

22.6.6.1.1 Common Configuration Data

One part of the message buffer configuration data is common to all individual message buffers and the receive shadow buffers. These data can only be set when the protocol is in the *POC:config* state.

The application configures the number of utilized individual message buffers by writing the message buffer number of the last utilized message buffer into the LAST_MB_UTIL field in the [Message Buffer Segment Size and Utilization Register \(MBSSUTR\)](#).

The application configures the size of the two segments of individual message buffers by writing the message buffer number of the last message buffer in the first segment into the LAST_MB_SEG1 field in the [Message Buffer Segment Size and Utilization Register \(MBSSUTR\)](#).

The application configures the length of the message buffer data fields for both of the message buffer segments by writing to the MBSEG2DS and MBSEG1DS fields in the [Message Buffer Data Size Register \(MBDSR\)](#).

Depending on the current receive functionality of the controller, the application must configure the receive shadow buffers. For each segment and for each channel with at least one individual receive message buffer assigned, the application must configure the related receive shadow buffer using the [Receive Shadow Buffer Index Register \(RSBIR\)](#).

22.6.6.1.2 Specific Configuration Data

The second part of the message buffer configuration data is specific for each message buffer.

These data can be changed only when either

- the protocol is in the *POC:config* state or
- the message buffer is disabled, i.e. MBCCSRn[EDS] = 0

The individual message buffer type is defined by the MTD and MBT bits in the [Message Buffer Configuration, Control, Status Registers \(MBCCSRn\)](#) as given in [Table 22-94](#).

Table 22-94. Individual Message Buffer Types

| MBCCSRn[MTD] | MBCCSRn[MBT] | Individual Message Buffer Description |
|--------------|--------------|---------------------------------------|
| 0 | 0 | Receive Message Buffer |
| 0 | 1 | Reserved |
| 1 | 0 | Single Transmit Message Buffer |
| 1 | 1 | Double Transmit Message Buffer |

The message buffer specific configuration data are

1. MCM, MBT, MTD bits in [Message Buffer Configuration, Control, Status Registers \(MBCCSRn\)](#)
2. all fields and bits in [Message Buffer Cycle Counter Filter Registers \(MBCCFRn\)](#)
3. all fields and bits in [Message Buffer Frame ID Registers \(MBFIDRn\)](#)
4. all fields and bits in [Message Buffer Index Registers \(MBIDXRn\)](#)

The meaning of the specific configuration data depends on the message buffer type, as given in the detailed message buffer type descriptions [Section 22.6.6.2, Single Transmit Message Buffers](#), [Section 22.6.6.3, Receive Message Buffers](#), and [Section 22.6.6.4, Double Transmit Message Buffer](#).

22.6.6.2 Single Transmit Message Buffers

The section provides a detailed description of the functionality of single buffered transmit message buffers.

A single transmit message buffer is used by the application to provide message data to the controller that will be transmitted over the FlexRay Bus. The controller uses the transmit message buffers to provide information about the transmission process and status information about the slot in which message was transmitted.

The individual message buffer with message buffer number n is configured to be a single transmit message buffer by the following settings:

- $MBCCSRn[MBT] = 0$ (single buffered message buffer)
- $MBCCSRn[MTD] = 1$ (transmit message buffer)

22.6.6.2.1 Access Regions

To certain message buffer fields, both the application and the controller have access. To ensure data consistency, a message buffer locking scheme is implemented, which is used to control the access to the data, control, and status bits of a message buffer. The access regions for single transmit message buffers are depicted in [Figure 22-119](#). A description of the regions is given in [Table 22-95](#). If an region is active as indicated in [Table 22-96](#), the access scheme given for that region applies to the message buffer.

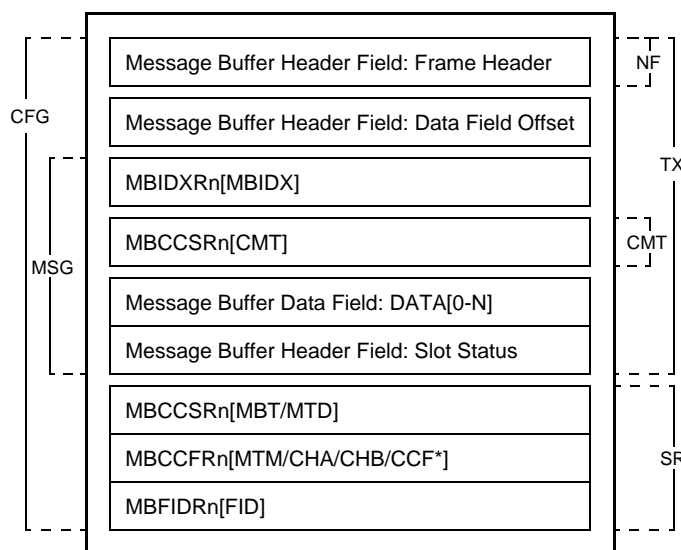

Figure 22-119. Single Transmit Message Buffer Access Regions

Table 22-95. Single Transmit Message Buffer Access Regions Description

| Region | Access from | | Region used for |
|--------|-------------|------------|---|
| | Application | Module | |
| CFG | read/write | - | Message Buffer Configuration |
| MSG | read/write | - | Message Data and Slot Status Access |
| NF | - | read-only | Message Header Access for Null Frame Transmission |
| TX | - | read/write | Message Transmission and Slot Status Update |
| CM | - | read-only | Message Buffer Validation |
| SR | - | read-only | Message Buffer Search |

The trigger bits MBCCSRn[EDT] and MBCCSRn[LCKT], and the interrupt enable bit MBCCSRn[MBIE] are not under access control and can be accessed from the application at any time. The status bits MBCCSRn[EDS] and MBCCSRn[LCKS] are not under access control and can be accessed from the controller at any time.

The interrupt flag MBCCSnR[MBIF] is not under access control and can be accessed from the application and the controller at any time. controller clear access has higher priority.

The controller restricts its access to the regions depending on the current state of the message buffer. The application must adhere to these restrictions in order to ensure data consistency. The transmit message buffer states are given in Figure 22-120. A description of the states is given in Table 22-96, which also provides the access scheme for the access regions.

The status bits MBCCSRn[EDS] and MBCCSRn[LCKS] provide the application with the required message buffer status information. The internal status information is not visible to the application.

22.6.6.2.2 Message Buffer States

This section describes the transmit message buffer states and provides a state diagram.

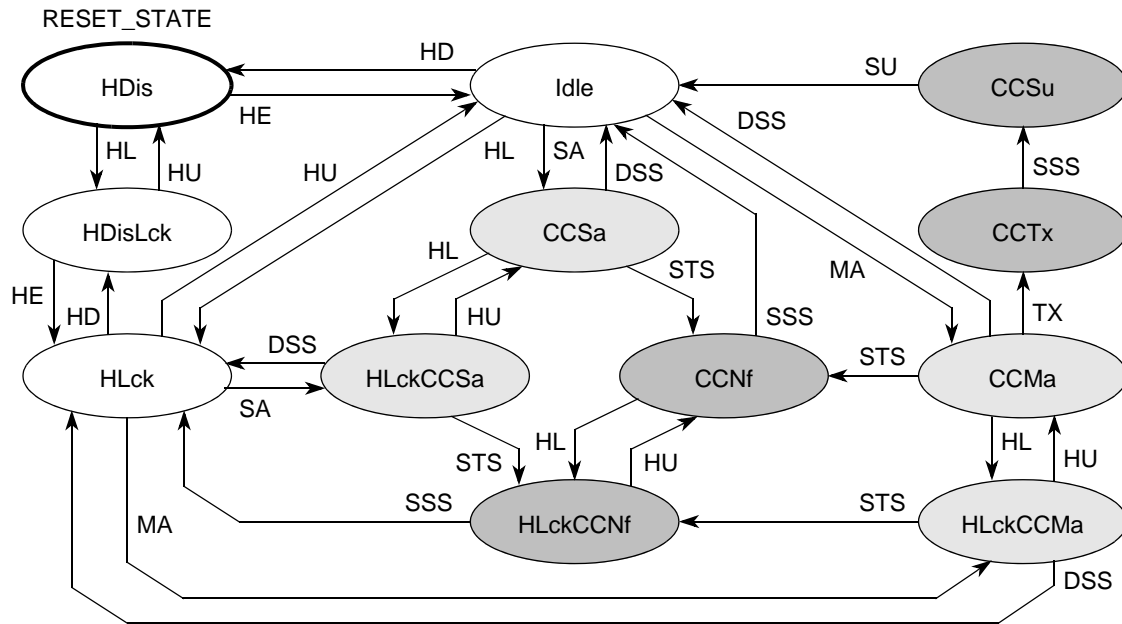

Figure 22-120. Single Transmit Message Buffer States

Table 22-96. Single Transmit Message Buffer State Description

| State | MBCCSRn | | Access Region | | Description |
|----------|---------|------|---------------|--------|---|
| | EDS | LCKS | Appl. | Module | |
| Idle | 1 | 0 | – | CM, SR | Idle - Message Buffer is idle. Included in message buffer search. |
| HDis | 0 | 0 | CFG | – | Disabled - Message Buffer under configuration. Excluded from message buffer search. |
| HDisLck | 0 | 1 | CFG | – | Disabled and Locked - Message Buffer under configuration. Excluded from message buffer search. |
| HLck | 1 | 1 | MSG | SR | Locked - Applications access to data, control, and status. Included in message buffer search. |
| CCSa | 1 | 0 | – | – | Slot Assigned - Message buffer assigned to next static slot. Ready for Null Frame transmission. |
| HLckCCSa | 1 | 1 | MSG | – | Locked and Slot Assigned - Applications access to data, control, and status. Message buffer assigned to next static slot |
| CCNf | 1 | 0 | – | NF | Null Frame Transmission Header is used for null frame transmission. |
| HLckCCNf | 1 | 1 | MSG | NF | Locked and Null Frame Transmission - Applications access to data, control, and status. Header is used for null frame transmission. |
| CCMa | 1 | 0 | – | CM | Message Available - Message buffer is assigned to next slot and cycle counter filter matches. |
| HLckCCMa | 1 | 1 | MSG | – | Locked and Message Available - Applications access to data, control, and status. Message buffer is assigned to next slot and cycle counter filter matches. |
| CCTx | 1 | 0 | – | TX | Message Transmission - Message buffer data transmit. Payload data from buffer transmitted |
| CCSu | 1 | 0 | – | TX | Status Update - Message buffer status update. Update of status flags, the slot status field, and the header index. |

22.6.6.2.3 Message Buffer Transitions

Application Transitions

The application transitions can be triggered by the application using the commands described in [Table 22-97](#). The application issues the commands by writing to the [Message Buffer Configuration, Control, Status Registers \(MBCCSRn\)](#). Only one command can be issued with one write access. Each command is executed immediately. If the command is ignored, it must be issued again.

Message Buffer Enable and Disable

The enable and disable commands issued by writing 1 to the trigger bit MBCCSRn[EDT]. The transition that will be triggered by each of these command depends on the current value of the status bit MBCCSRn[EDS]. If the command triggers the disable transition HD and the message buffer is in one of the states CCSa, HLckCCSa, CCMa, HLckCCMa, CCNf, HLckCCNf, or CCTx, the disable transition has no effect (command is ignored) and the message buffer state is not changed. No notification is given to the application.

Message Buffer Lock and Unlock

The lock and unlock commands issued by writing 1 to the trigger bit MBCCSRn[LCKT]. The transition that will be triggered by each of these commands depends on the current value of the status bit MBCCSRn[LCKS]. If the command triggers the lock transition HL and the message buffer is in the state CCTx, the lock transition has no effect (command is ignored) and message buffer state is not changed. In this case, the message buffer lock error flag LCK_EF in the [CHI Error Flag Register \(CHIERFR\)](#) is set.

Table 22-97. Single Transmit Message Buffer Application Transitions

| Transition | Command | Condition | Description |
|------------|-------------------|-------------------|--|
| HE | MBCCSRn[EDT]:= 1 | MBCCSRn[EDS] = 0 | Application triggers message buffer enable. |
| HD | | MBCCSRn[EDS] = 1 | Application triggers message buffer disable. |
| HL | MBCCSRn[LCKT]:= 1 | MBCCSRn[LCKS] = 0 | Application triggers message buffer lock. |
| HU | | MBCCSRn[LCKS] = 1 | Application triggers message buffer unlock. |

Module Transitions

The module transitions that can be triggered by the controller are described in [Table 22-98](#). Each transition will be triggered for certain message buffers when the related condition is fulfilled.

Table 22-98. Single Transmit Message Buffer Module Transitions

| Transition | Condition | Description |
|------------|-----------------------------------|--|
| SA | slot match and static slot | Slot Assigned - Message buffer is assigned to next static slot. |
| MA | slot match and CycleCounter match | Message Available - Message buffer is assigned to next slot and cycle counter filter matches. |
| TX | slot start and MBCCSRn[CMT] = 1 | Transmission Slot Start - Slot Start and commit bit CMT is set. In case of a dynamic slot, pLatestTx is not exceeded. |
| SU | status updated | Status Updated - Slot Status field and message buffer status flags updated. Interrupt flag set. |
| STS | static slot start | Static Slot Start - Start of static slot. |

Table 22-98. Single Transmit Message Buffer Module Transitions (continued)

| Transition | Condition | Description |
|------------|--|--|
| DSS | dynamic slot start or symbol window start or NIT start | Dynamic Slot or Segment Start. - Start of dynamic slot or symbol window or NIT. |
| SSS | slot start or symbol window start or NIT start | Slot or Segment Start - Start of static slot or dynamic slot or symbol window or NIT. |

Transition Priorities

The application can trigger only one transition at a time. There is no need to specify priorities among them.

As shown in the first part of [Table 22-99](#), the module transitions have a higher priority than the application transitions. For all states except the CCMA state, both a lock/unlock transition HL/HD and a module transition can be executed at the same time. The result state is reached by first applying the application transition and subsequently the module transition to the intermediately reached state. For example, if the message buffer is in the HLck state and the application unlocks the message buffer by the HU transition and the module triggers the slot assigned transition SA, the intermediate state is Idle and the resulting state is CCSa.

The priorities among the module transitions is given in the second part of [Table 22-99](#).

Table 22-99. Single Transmit Message Buffer Transition Priorities

| State | Priorities | Description |
|-------------------------------|------------|--|
| module vs. application | | |
| Idle, HLck | SA > HD | Slot Assigned > Message Buffer Disable |
| | MA > HD | Message Available > Message Buffer Disable |
| CCMa | TX > HL | Transmission Start > Message Buffer Lock |
| module internal | | |
| Idle, HLck | MA > SA | Message Available > Slot Assigned |
| CCMa | TX > STS | Transmission Slot Start > Static Slot Start |
| | TX > DSS | Transmission Slot Start > Dynamic Slot Start |

22.6.6.2.4 Transmit Message Setup

To transmit a message over the FlexRay bus, the application writes the message data into the message buffer data field and sets the commit bit CMT in the [Message Buffer Configuration, Control, Status Registers \(MBCCSRn\)](#). The physical access to the message buffer data field is described in [Section 22.6.3.1, Individual Message Buffers](#).

As indicated by [Table 22-96](#), the application shall write to the message buffer data field and change the commit bit CMT only if the transmit message buffer is in one of the states HDIs, HDIsLck, HLck, HLckCCSa, HLckCCMa, or HLckCCMa. The application can change the state of a message buffer if it issues the appropriate commands shown in [Table 22-97](#). The state change is indicated through the MBCCSRn[EDS] and MBCCSRn[LCKS] status bits.

If the transmit message buffer enters one of the states HDIs, HDIsLck, HLck, HLckCCSa, HLckCCMa, or HLckCCMa the MBCCSRn[DVAL] flag is negated.

22.6.6.2.5 Message Transmission

As a result of the message buffer search described in [Section 22.6.7, Individual Message Buffer Search](#), the controller triggers the message available transition MA for up to two transmit message buffers. This changes the message buffer state from Idle to CCMa and the message buffers can be used for message transmission in the next slot.

The controller transmits a message from a message buffer if both of the following two conditions are fulfilled at the start of the transmission slot:

1. the message buffer is in the message available state CCMa
2. the message data are still valid, i.e. $MBCCSR_n[CMT] = 1$

In this case, the controller triggers the TX transition and changes the message buffer state to CCTx. A transmit message buffer timing and state change diagram for message transmission is given in [Figure 22-121](#). In this example, the message buffer with message buffer number n is Idle at the start of the search slot, matches the slot and cycle number of the next slot, and message buffer data are valid, i.e. $MBCCSR_n[CMT] = 1$.

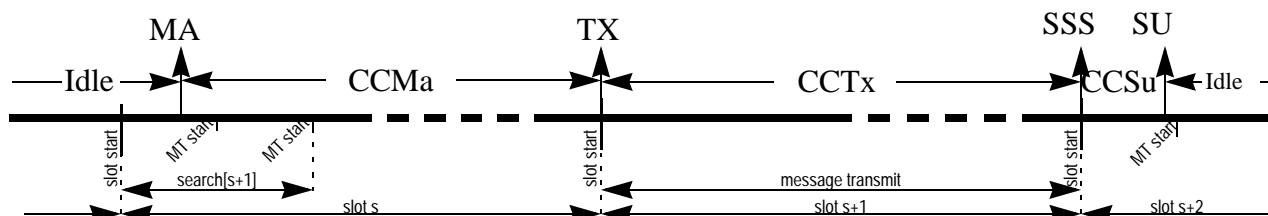

Figure 22-121. Message Transmission Timing

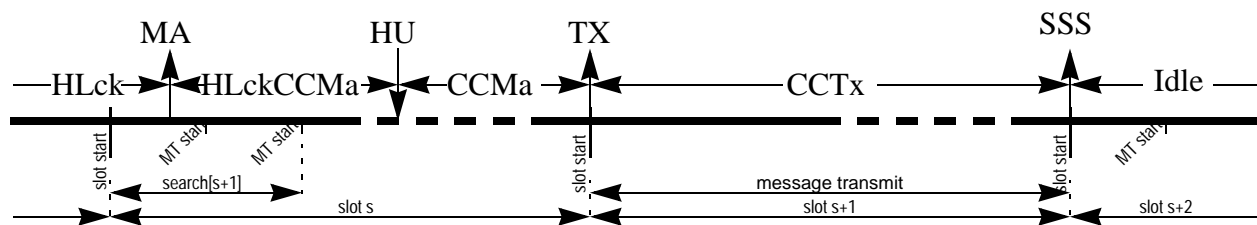

Figure 22-122. Message Transmission from HLck state with unlock

The amount of message data read from the flexray memory and transferred to the FlexRay bus is determined by the following three items:

- The message buffer segment that the message buffer is assigned to, as defined by the [Message Buffer Segment Size and Utilization Register \(MBSSUTR\)](#).
- The message buffer data field size, as defined by the related field of the [Message Buffer Data Size Register \(MBDSR\)](#)
- The value of the PLDLEN field in the message buffer header field, as described in [Section 22.6.5.2.1, Frame Header Description](#)

If a message buffer is assigned to message buffer segment 1, and $PLDLEN > MBSEG1DS$, then $2 * MBSEG1DS$ bytes will be read from the message buffer data field and zero padding is used for the remaining bytes for the FlexRay bus transfer. If $PLDLEN \leq MBSEG1DS$, the controller reads and transfers $2 * PLDLEN$ bytes. The same holds for segment 2 and $MBSEG2DS$.

22.6.6.2.6 Null Frame Transmission

A static slot with slot number S is assigned to the controller for channel A, if at least one transmit message buffer is configured with the $MBFIDRn[FID]$ set to S and $MBCCFRn[CHA]$ set to 1. A Null Frame is transmitted in the static slot S on channel A, if this slot is assigned to the controller for channel A, and all transmit message buffers with $MBFIDRn[FID] = s$ and $MBCCFRn[CHA] = 1$ are either not committed, i.e. $MBCCSRn[CMT] = 0$, or locked by the application, i.e. $MBCCSRn[LCKS] = 1$, or the cycle counter filter is enabled and does not match.

Additionally, the application can clear the commit bit of a message buffer that is in the $CCMa$ state, which is called *uncommit* or *transmit abort*. This message buffer will be used for null frame transmission.

As a result of the message buffer search described in [Section 22.6.7, Individual Message Buffer Search](#), the controller triggers the slot assigned transition SA for up to two transmit message buffers if at least one of the conditions mentioned above is fulfilled for these message buffers. The transition SA changes the message buffer states from either $Idle$ to $CCSa$ or from $HLck$ to $HLckCCSa$. In each case, these message buffers will be used for null frame transmission in the next slot. A message buffer timing and state change diagram for null frame transmission from $Idle$ state is given in [Figure 22-123](#).

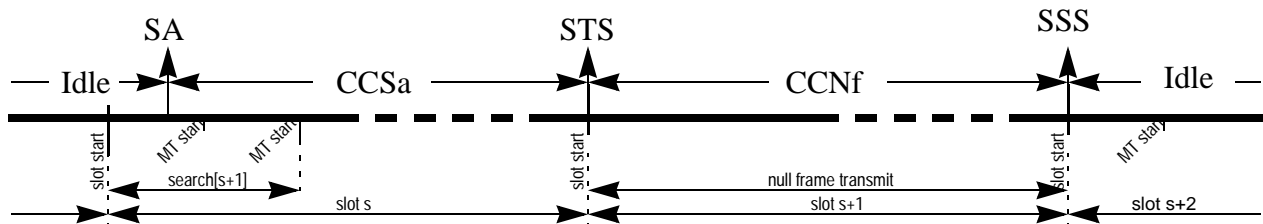

Figure 22-123. Null Frame Transmission from Idle state

A message buffer timing and state change diagram for null frame transmission from $HLck$ state is given in [Figure 22-124](#).

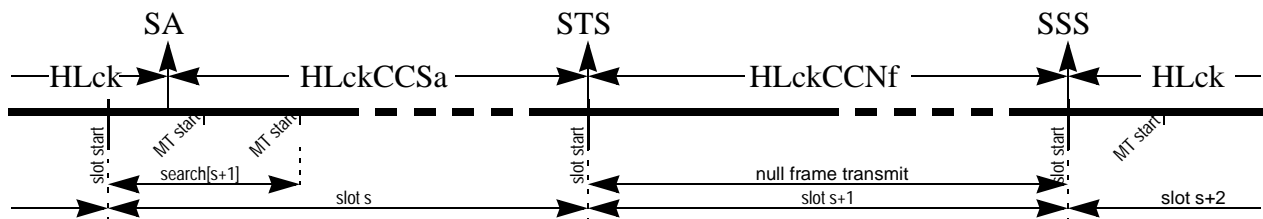

Figure 22-124. Null Frame Transmission from HLck state

If a transmit message buffer is in the $CCSa$ or $HLckCCSa$ state at the start of the transmission slot, a null frame is transmitted in any case, even if the message buffer is unlocked or committed before the transmission slot starts. A transmit message buffer timing and state change diagram for null frame transmission for this case is given in [Figure 22-125](#).

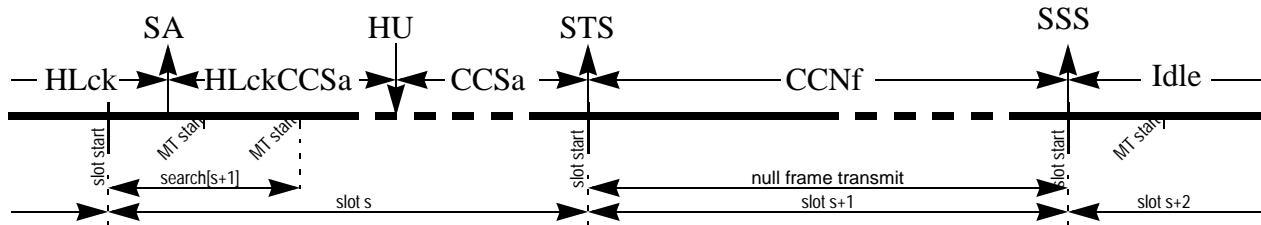

Figure 22-125. Null Frame Transmission from HLck state with unlock

Since the null frame transmission will not use the message buffer data, the application can lock/unlock the message buffer during null frame transmission. A transmit message buffer timing and state change diagram for null frame transmission for this case is given in Figure 22-126.

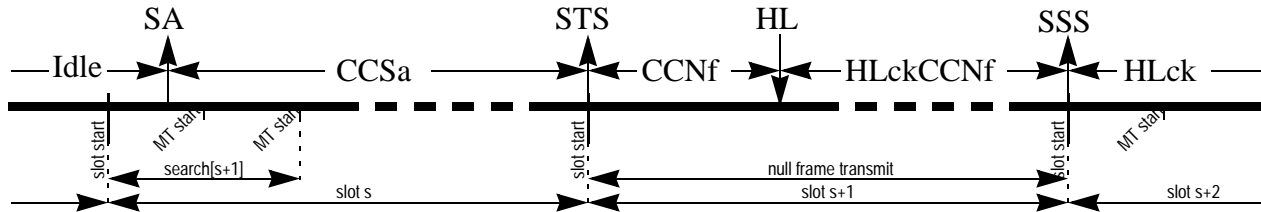

Figure 22-126. Null Frame Transmission from Idle state with locking

22.6.6.2.7 Message Buffer Status Update

After the end of each slot, the PE generates the slot status vector. Depending on the this status, the transmitted frame type, and the amount of transmitted data, the message buffer status is updated.

Message Buffer Status Update after Complete Message Transmission

The term complete message transmission refers to the fact that all payload data stored in the message buffer were send to FlexRay bus. In this case, the controller updates the slot status field of the message buffer and triggers the status updated transition SU. With the SU transition, the controller sets the message buffer interrupt flag MBCCSn[MBIF] to indicate the successful message transmission.

Depending on the transmission mode flag MBCCFRn[MTM], the controller changes the commit flag MBCCSRn[CMT] and the valid flag MBCCSRn[DVAL]. If the MBCCFRn[MTM] flag is negated, the message buffer is in the *event transmission mode*. In this case, each committed message is transmitted only once. The commit flag MBCCSRn[CMT] is cleared with the SU transition. If the MBCCFRn[MTM] flag is asserted, the message buffer is in the *state transmission mode*. In this case, each committed message is transmitted as long as the application provides new data or locks the message buffers. The controller will not clear the MBCCSRn[CMT] flag at the end of transmission and will set the valid flag MBCCSRn[DVAL] to indicate that the message will be transmitted again.

Message Buffer Status Update after Incomplete Message Transmission

The term incomplete message transmission refers to the fact that not all payload data that should be transmitted were sent to FlexRay bus. This may be caused by the following regular conditions in the dynamic segment:

1. The transmission slot starts in a minislot with a minislot number greater than *pLatestTx*.
2. The transmission slot did not exist in the dynamic segment at all.

Additionally, an incomplete message transmission can be caused by internal communication errors. If those error occur, the Protocol Engine Communication Failure Interrupt Flag PECF_IF is set in the [Protocol Interrupt Flag Register 1 \(PIFR1\)](#).

In any of these two cases, the status of the message buffer is not changed at all with the SU transition. The slot status field is not updated, the status and control flags are not changed, and the interrupt flag is not set.

Message Buffer Status Update after Null Frame Transmission

After the transmission of a null frame, the status of the message buffer that was used for the null frame transmission is not changed at all. The slot status field is not updated, the status and control flags are not changed, and the interrupt flag is not set.

22.6.6.3 Receive Message Buffers

The section provides a detailed description of the functionality of the receive message buffers.

A receive message buffer is used to receive a message from the FlexRay Bus based on individual filter criteria. The controller uses the receive message buffer to provide the following data to the application

1. message data received
2. information about the reception process
3. status information about the slot in which the message was received

A individual message buffer with message buffer number *n* is configured as a receive message buffer by the following configuration settings

- MBCCSRn[MBT] = 0 (single buffered message buffer)
- MBCCSRn[MTD] = 0 (receive message buffer)

To certain message buffer fields, both the application and the controller have access. To ensure data consistency, a message buffer locking scheme is implemented that is used to control the access to the data, control, and status bits of a message buffer. The access regions for receive message buffers are depicted in [Figure 22-127](#). A description of the regions is given in [Table 22-100](#). If an region is active as indicated in [Table 22-101](#), the access scheme given for that region applies to the message buffer.

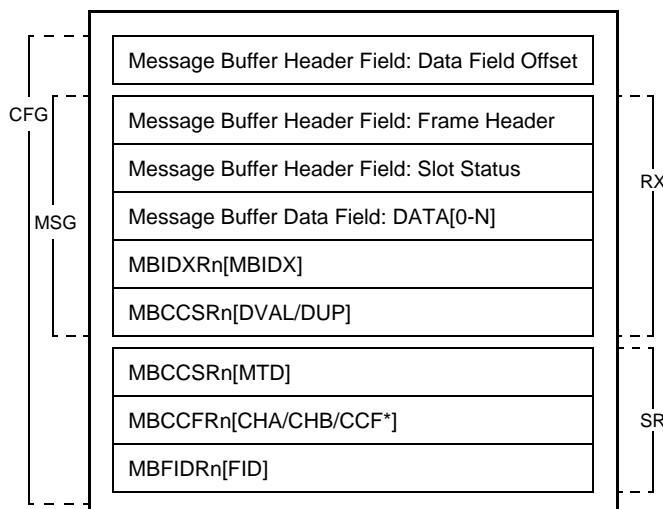

Figure 22-127. Receive Message Buffer Access Regions

Table 22-100. Receive Message Buffer Access Region Description

| Region | Access from | | Region used for |
|--------|-------------|------------|--|
| | Application | Module | |
| CFG | read/write | - | Message Buffer Configuration, Message Data and Status Access |
| MSG | read/write | - | Message Data, Header, and Status Access |
| RX | - | write-only | Message Reception and Status Update |
| SR | - | read-only | Message Buffer Search Data |

The trigger bits MBCCSRn[EDT] and MBCCSRn[LCKT] and the interrupt enable bit MBCCSRn[MBIE] are not under access control and can be accessed from the application at any time. The status bits MBCCSRn[EDS] and MBCCSRn[LCKS] are not under access control and can be accessed from the controller at any time.

The interrupt flag MBCCSRn[MBIF] is not under access control and can be accessed from the application and the controller at any time. controller set access has higher priority.

The controller restricts its access to the regions depending on the current state of the message buffer. The application must adhere to these restrictions in order to ensure data consistency. The receive message buffer states are given in Figure 22-128. A description of the message buffer states is given in Table 22-96, which also provides the access scheme for the access regions.

The status bits MBCCSRn[EDS] and MBCCSRn[LCKS] provide the application with the required status information. The internal status information is not visible to the application.

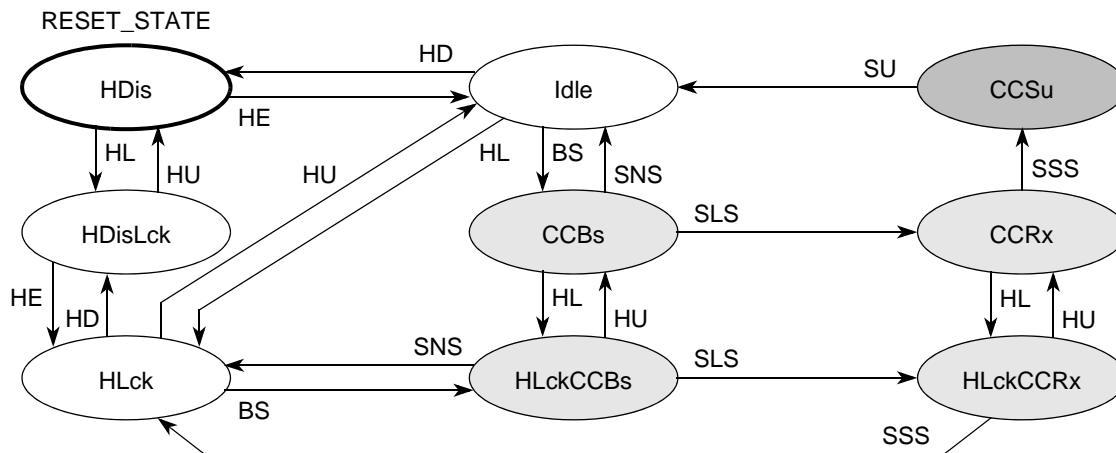

Figure 22-128. Receive Message Buffer States

Table 22-101. Receive Message Buffer States and Access

| State | MBCCSRn | | Access from | | Description |
|----------|---------|------|-------------|--------|---|
| | EDS | LCKS | Appl. | Module | |
| Idle | 1 | 0 | – | SR | Idle - Message Buffer is idle. Included in message buffer search. |
| HDis | 0 | 0 | CFG | – | Disabled - Message Buffer under configuration. Excluded from message buffer search. |
| HDisLck | 0 | 1 | CFG | – | Disabled and Locked - Message Buffer under configuration. Excluded from message buffer search. |
| HLck | 1 | 1 | MSG | – | Locked - Applications access to data, control, and status. Included in message buffer search. |
| CCBs | 1 | 0 | – | – | Buffer Subscribed - Message buffer subscribed for reception. Filter matches next (slot, cycle, channel) tuple. |
| HLckCCBs | 1 | 1 | MSG | – | Locked and Buffer Subscribed - Applications access to data, control, and status. Message buffer subscribed for reception. |
| CCRx | 1 | 0 | – | – | Message Receive - Message data received into related shadow buffer. |
| HLckCCRx | 1 | 1 | MSG | – | Locked and Message Receive - Applications access to data, control, and status. Message data received into related shadow buffer. |
| CCSu | 1 | 0 | – | RX | Status Update - Message buffer status update. Update of status flags, the slot status field, and the header index. |

22.6.6.3.1 Message Buffer Transitions

Application Transitions

The application transitions that can be triggered by the application using the commands described in [Table 22-102](#). The application issues the commands by writing to the [Message Buffer Configuration, Control, Status Registers \(MBCCSRn\)](#). Only one command can be issued with one write access. Each command is executed immediately. If the command is ignored, it must be issued again.

Message Buffer Enable and Disable

The enable and disable commands issued by writing 1 to the trigger bit MBCCSRn[EDT]. The transition that will be triggered by each of these command depends on the current value of the status bit MBCCSRn[EDS]. If the command triggers the disable transition HD and the message buffer is in one of the states CCBs, HLckCCBs, or CCRx, the disable transition has no effect (command is ignored) and the message buffer state is not changed. No notification is given to the application.

Message Buffer Lock and Unlock

The lock and unlock commands issued by writing 1 to the trigger bit MBCCSRn[LCKT]. The transition that will be triggered by each of these commands depends on the current value of the status bit MBCCSRn[LCKS]. If the command triggers the lock transition HL while the message buffer is in the state CCRx, the lock transition has no effect (command is ignored) and message buffer state is not changed. In this case, the message buffer lock error flag LCK_EF in the [CHI Error Flag Register \(CHIERFR\)](#) is set.

Table 22-102. Receive Message Buffer Application Transitions

| Transition | Host Command | Condition | Description |
|------------|-------------------|-------------------|--|
| HE | MBCCSRn[EDT]:= 1 | MBCCSRn[EDS] = 0 | Application triggers message buffer enable. |
| HD | | MBCCSRn[EDS] = 1 | Application triggers message buffer disable. |
| HL | MBCCSRn[LCKT]:= 1 | MBCCSRn[LCKS] = 0 | Application triggers message buffer lock. |
| HU | | MBCCSRn[LCKS] = 1 | Application triggers message buffer unlock. |

Module Transitions

The module transitions that can be triggered by the controller are described in [Table 22-103](#). Each transition will be triggered for certain message buffers when the related condition is fulfilled.

Table 22-103. Receive Message Buffer Module Transitions

| Transition | Condition | Description |
|------------|--|---|
| BS | slot match and CycleCounter match | Buffer Subscribed - The message buffer filter matches next slot and cycle. |
| SLS | slot start | Slot Start - Start of either Static Slot or Dynamic Slot. |
| SNS | symbol window start or NIT start | Symbol Window or NIT Start - Start of either Symbol Window or NIT. |
| SSS | slot start or symbol window start or NIT start | Slot or Segment Start - Start of either Static Slot, Dynamic Slot, Symbol Window, or NIT. |
| SU | status updated | Status Updated - Slot Status field, message buffer status flags, header index updated. Interrupt flag set. |

Transition Priorities

The application can trigger only one transition at a time. There is no need to specify priorities among them.

As shown in [Table 22-104](#), the module transitions have a higher priority than the application transitions. For all states except the CCRx state, a module transition and the application lock/unlock transition HL/HU and can be executed at the same time. The result state is reached by first applying the module transition and subsequently the application transition to the intermediately reached state. For example, if the message buffer is in the buffer subscribed state CCBs and the module triggers the slot start transition SLS at the

same time as the application locks the message buffer by the HL transition, the intermediate state is CCRx and the resulting state is locked buffer subscribed state HLckCCRx.

Table 22-104. Receive Message Buffer Transition Priorities

| State | Priorities | Description |
|-------------------------------|------------|---|
| module vs. application | | |
| Idle | BS > HD | Buffer Subscribed > Message Buffer Disable |
| HLck | BS > HD | Buffer Subscribed > Message Buffer Disable |
| CCRx | SSS > HL | Slot or Segment Start > Message Buffer Lock |

22.6.6.3.2 Message Reception

As a result of the message buffer search, the controller changes the state of up to two enabled receive message buffers from either idle state Idle or locked state HLck to the either subscribed state CCBs or locked buffer subscribed state HLckCCBs by triggering the buffer subscribed transition BS.

If the receive message buffers for the next slot are assigned to both channels, then at most one receive message buffer is changed to a buffer subscribed state.

If more than one matching message buffers assigned to a certain channel, then only the message buffer with the lowest message buffer number is in one of the states mentioned above.

With the start of the next static or dynamic slot the module trigger the slot start transition SLS. This changes the state of the subscribed receive message buffers from either CCBs to CCRx or from HLckCCBs to HLckCCRx, respectively.

During the reception slot, the received frame data are written into the shadow buffers. For details on receive shadow buffers, see [Section 22.6.6.3.5, Receive Shadow Buffers Concept](#). The data and status of the receive message buffers that are the CCRx or HLckCCRx are not modified in the reception slot.

22.6.6.3.3 Message Buffer Update

With the start of the next static or dynamic slot or with the start of the symbol window or NIT, the module triggers the slot or segment start transition SSS. This transition changes the state of the receiving receive message buffers from either CCRx to CCSu or from HLckCCRx to HLck, respectively.

If a message buffer was in the locked state HLckCCRx, no update will be performed. The received data are lost. This is indicated by setting the Frame Lost Channel A/B Error Flag FRLA_EF/FRLB_EF in the [CHI Error Flag Register \(CHIERFR\)](#).

If a message buffer was in the CCRx state it is now in the CCSu state. After the evaluation of the slot status provided by the PE the message buffer is updated. The message buffer update depends on the slot status bits and the segment the message buffer is assigned to. This is described in [Table 22-105](#).

Table 22-105. Receive Message Buffer Update

| <i>vSS!ValidFrame</i> | <i>vRF!Header!NFIndicator</i> | Update description |
|-----------------------|-------------------------------|---|
| 1 | 1 | Valid non-null frame received. - Message Buffer Data Field updated. - Frame Header Field updated. - Slot Status Field updated. - DUP:= 1 - DVAL:= 1 - MBIF:= 1 |
| 1 | 0 | Valid null frame received. - Message Buffer Data Field <i>not</i> updated. - Frame Header Field <i>not</i> updated. - Slot Status Field updated. - DUP:= 0 - DVAL <i>not</i> changed - MBIF:= 1 |
| 0 | x | No valid frame received. - Message Buffer Data Field not updated. - Frame Header Field not updated. - Slot Status Field updated. - DUP:= 0 - DVAL <i>not</i> changed. - MBIF:= 1, if the slot was not an empty dynamic slot. Note: An empty dynamic slot is indicated by the following frame and slot status bit values: <i>vSS!ValidFrame</i> = 0 and <i>vSS!SyntaxError</i> = 0 and <i>vSS!ContentError</i> = 0 and <i>vSS!BViolation</i> = 0. |

NOTE

If the number of the last slot in the current communication cycle on a given channel is n , then all receive message buffers assigned to this channel with $MBFIDR_n[FID] > n$ will not be updated at all.

When the receive message buffer update has finished the status updated transition SU is triggered, which changes the buffer state from CCSu to Idle. An example receive message buffer timing and state change diagram for a normal frame reception is given in Figure 22-129.

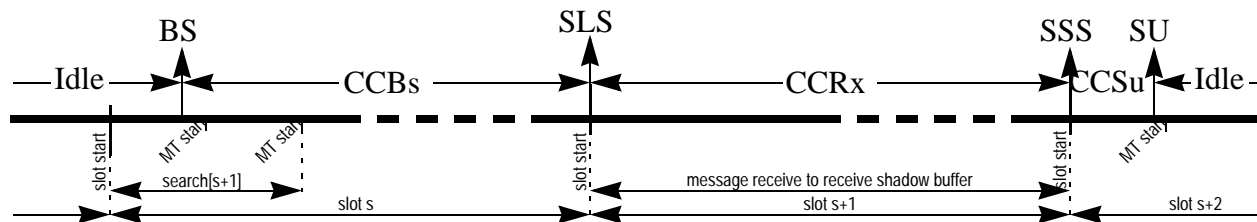

Figure 22-129. Message Reception Timing

The amount of message data written into the message buffer data field of the receive shadow buffer is determined by the following two items:

1. the message buffer segment that the message buffer is assigned to, as defined by the [Message Buffer Segment Size and Utilization Register \(MBSSUTR\)](#).

2. the message buffer data field size, as defined by the related field of the [Message Buffer Data Size Register \(MBDSR\)](#)
3. the number of bytes received over the FlexRay bus

If the message buffer is assigned to the message buffer segment 1, and the number of received bytes is greater than $2 * \text{MBDSR.MBSEG1DS}$, the controller writes only $2 * \text{MBDSR.MBSEG1DS}$ bytes into the message buffer data field of the receive shadow buffer. If the number of received bytes is less than $2 * \text{MBDSR.MBSEG1DS}$, the controller writes only the received number of bytes and will not change the trailing bytes in the message buffer data field of the receive shadow buffer. The same holds for the message buffer segment 2 with MBDSR.MBSEG2DS .

22.6.6.3.4 Received Message Access

To access the message data received over the FlexRay bus, the application reads the message data stored in the message buffer data field of the corresponding receive message buffer. The access to the message buffer data field is described in [Section 22.6.3.1, Individual Message Buffers](#).

The application can read the message buffer data field if the receive message buffer is one of the states `HDis`, `HDisLck`, or `HLck`. If the message buffer is in one of these states, the controller will not change the content of the message buffer.

22.6.6.3.5 Receive Shadow Buffers Concept

The receive shadow buffer concept applies only to individual receive message buffers. The intention of this concept is to ensure that only syntactically and semantically valid received non-null frames are presented to the application in a receive message buffer. The basic structure of a receive shadow buffer is described in [Section 22.6.3.2, Receive Shadow Buffers](#).

The receive shadow buffers temporarily store the received frame header and message data. After the slot boundary the slot status information is generated. If the slot status information indicates the reception of the valid non-null frame (see [Table 22-105](#)), the controller writes the slot status into the slot status field of the receive shadow buffer and exchanges the content of the [Message Buffer Index Registers \(MBIDXRn\)](#) with the content of the corresponding internal shadow buffer index register. In all other cases, the controller writes the slot status into the identified receive message buffer, depending on the slot status and the FlexRay segment the message buffer is assigned to.

The shadow buffer concept, with its index exchange, results in the fact that the flexray memory located message buffer associated to an individual receive message buffer changes after successful reception of a valid frame. This means that the message buffer area in the flexray memory accessed by the application for reading the received message is different from the initial setting of the message buffer. Therefore, the application must not rely on the index information written initially into the [Message Buffer Index Registers \(MBIDXRn\)](#). Instead, the index of the message buffer header field must be fetched from the [Message Buffer Index Registers \(MBIDXRn\)](#).

22.6.6.4 Double Transmit Message Buffer

The section provides a detailed description of the functionality of the double transmit message buffers.

Double transmit message buffers are used by the application to provide the controller with the message data to be transmitted over the FlexRay Bus. The controller uses this message buffer to provide information to the application about the transmission process, and status information about the slot in which message data was transmitted.

In contrast to the single transmit message buffers, the application can provide new transmission data while the transmission of the previously provided message data is running. This scheme is called double buffering and can be considered as a FIFO of depth 2.

Double transmit message buffers are implemented by combining two individual message buffers that form the two sides of an double transmit message buffer. One side is called the *commit side* and will be accessed by the application to provide the message data. The other side is called the *transmit side* and is used by the controller to transmit the message data to the FlexRay bus. The two sides are located in adjacent individual message buffers. The message buffer that implements the commit side has an even message buffer number $2n$. The transmit side message buffer follows the commit side message buffer and has the message buffer number $2n+1$. The basic structure and data flow of a double transmit message buffer is given in [Figure 22-130](#).

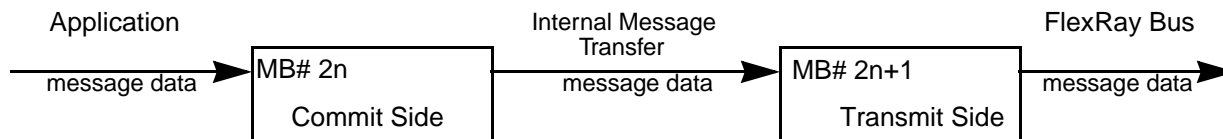

Figure 22-130. Double Transmit Buffer Structure and Data Flow

NOTE

Both the commit and the transmit side must be configured with identical values except for the [Message Buffer Index Registers \(MBIDXRn\)](#).

22.6.6.4.1 Access Regions

To certain message buffer fields, both the application and the controller have access. To ensure data consistency, a message buffer locking scheme is implemented, which controls the exclusive access to the data, control, and status bits of the message buffer.

The access scheme for double transmit message buffers is depicted in [Figure 22-131](#). The given regions represent fields that can be accessed from both the application and the controller and, thus, require access restrictions. A description of the regions is given in [Table 22-106](#).

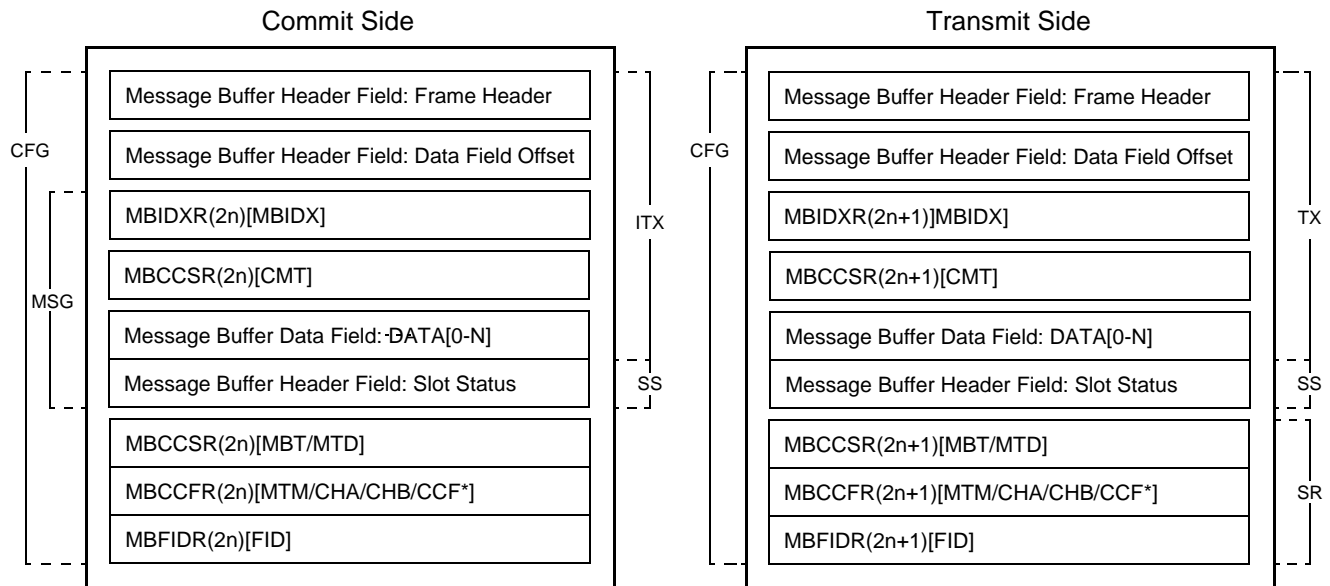
Figure 22-131. Double Transmit Message Buffer Access Regions Layout
Table 22-106. Double Transmit Message Buffer Access Regions Description

| Access | | | Description |
|----------------------|-------------|------------|---|
| Region | Type | | |
| | Application | Module | |
| Commit Side | | | |
| CFG | read/write | - | Message Buffer Configuration |
| MSG | read/write | - | Message Buffer Data and Control access |
| ITX | - | read/write | Internal Message Transfer. |
| SS | - | write-only | Slot Status Update |
| Transmit Side | | | |
| CFG | read/write | - | Message Buffer Configuration |
| SR | - | read-only | Message Buffer Search |
| TX | - | read-only | Internal Message Transfer, Message Transmission |
| SS | - | write-only | Slot Status Update |

The trigger bits MBCCSRn[EDT] and MBCCSRn[LCKT], and the interrupt enable bit MBCCSRn[MBIE] are not under access control and can be accessed from the application at any time. The status bits MBCCSRn[EDS] and MBCCSRn[LCKS] are not under access control and can be accessed from the controller at any time.

The interrupt flag MBCCSnR.MBIF is not under access control and can be accessed from the application and the controller at any time. controller set access has higher priority.

The controller restricts its access to the regions, depending on the current state of the corresponding part of the double transmit message buffer. The application must adhere to these restrictions in order to ensure data consistency. The states for the commit side of a double transmit message buffer are given in [Figure 22-132](#). A description of the states is given in [Table 22-108](#). The states for the transmit side of a

double transmit message buffer are given in [Figure 22-133](#). A description of the states is given in [Table 22-108](#). The description tables also provide the access scheme for the access regions.

The status bits MBCCSRn[EDS] and MBCCSRn[LCKS] provide the application with the required message buffer status information. The internal status information is not visible to the application.

22.6.6.4.2 Message Buffer States

This section describes the transmit message buffer states and provides a state diagram.

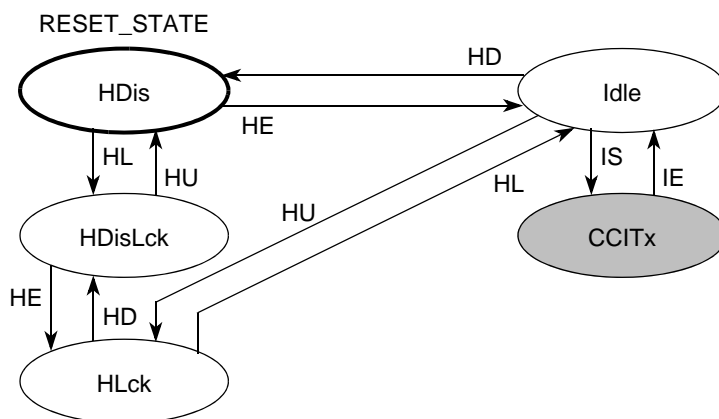
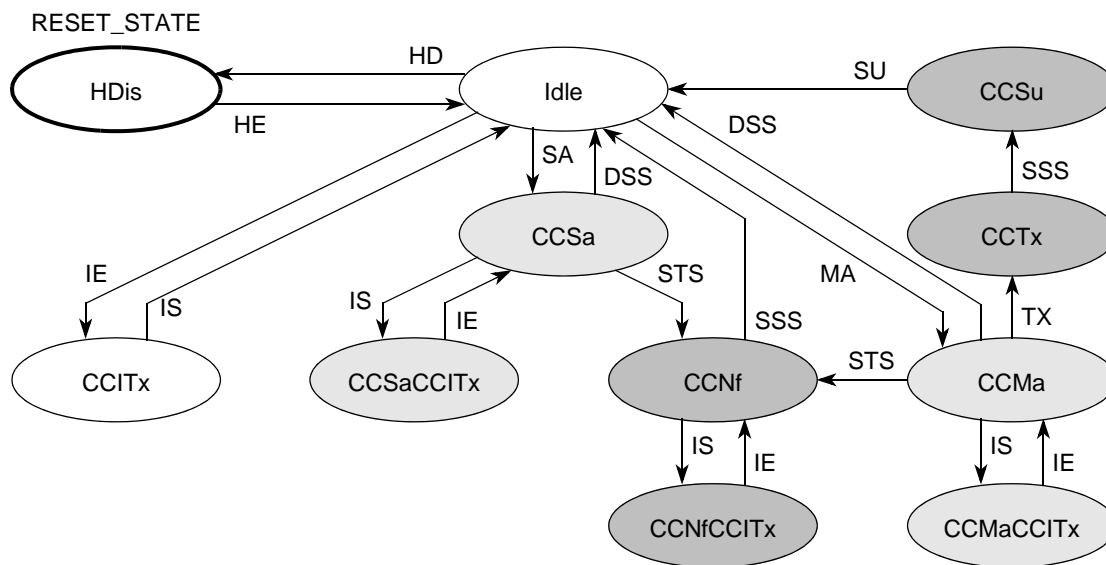

Figure 22-132. Double Transmit Message Buffer State Diagram (Commit Side)

A description of the states of the commit side of a double transmit message buffer is given in [Table 22-107](#).

Table 22-107. Double Transmit Message Buffer State Description (Commit Side)

| State | MBCCSR(2n) | | Access Region | | Description |
|-----------------------------|------------|------|---------------|---------|---|
| | EDS | LCKS | Appl. | Module | |
| common states | | | | | |
| HDis | 0 | 0 | CFG | – | Disabled - Message Buffer under configuration. Commit Side can <i>not</i> be used for internal message transfer. |
| CCITx | 1 | 0 | – | ITX | Internal Message Transfer - Message Buffer Data transferred from commit side to transmit side. |
| commit side specific states | | | | | |
| Idle | 1 | 0 | – | ITX, SS | Idle - Message Buffer Commit Side is idle. Commit Side can be used for internal message transfer. |
| HDisLck | 0 | 1 | CFG | SS | Disabled and Locked - Message Buffer under configuration. Commit Side can <i>not</i> be used for internal message transfer. |
| HLck | 1 | 1 | MSG | SS | Locked - Applications access to data, control, and status. Commit Side can <i>not</i> be used for internal message transfer. |

Figure 22-133. Double Transmit Message Buffer State Diagram (Transmit Side)

A description of the states of the transmit side of a double transmit message buffer is given in [Table 22-108](#).

Table 22-108. Double Transmit Message Buffer State Description (Transmit Side)

| State | MBCCSRn | | Access Region | | Description |
|-------------------------------|---------|------|---------------|--------|--|
| | EDS | LCKS | Appl. | Module | |
| common states | | | | | |
| HDis | 0 | 0 | CFG | – | Disabled - Message Buffer under configuration. Excluded from message buffer search. |
| CCITx | 1 | 0 | – | TX | Internal Message Transfer - Message Buffer Data transferred from commit side to transmit side. |
| transmit side specific states | | | | | |
| Idle | 1 | 0 | – | SR | Idle - Message Buffer Transmit Side is idle. Transmit Side is included in message buffer search. |
| CCSa | 1 | 0 | – | – | Slot Assigned - Message buffer assigned to next static slot. Ready for Null Frame transmission. |
| CCSaCCITx | 1 | 0 | – | TX | Slot Assigned and Internal Message Transfer - Message buffer assigned to next static slot and Message Buffer Data transferred from commit side to transmit side. |
| CCNf | 1 | 0 | – | TX | Null Frame Transmission Header is used for null frame transmission. |
| CCNfCCITx | 1 | 0 | – | TX | Null Frame Transmission and Internal Message Transfer - Header is used for null frame transmission and Message Buffer Data transferred from commit side to transmit side. |
| CCMa | 1 | 0 | – | – | Message Available - Message buffer is assigned to next slot and cycle counter filter matches. |
| CCMaCCITx | 1 | 0 | – | – | Message Available and Internal Message Transfer - Message buffer is assigned to next slot and cycle counter filter matches and Message Buffer Data transferred from commit side to transmit side. |

Table 22-108. Double Transmit Message Buffer State Description (Transmit Side) (continued)

| State | MBCCSRn | | Access Region | | Description |
|-------|---------|------|---------------|--------|--|
| | EDS | LCKS | Appl. | Module | |
| CCTx | 1 | 0 | – | TX | Message Transmission - Message buffer data transmit. Payload data from buffer transmitted |
| CCSu | 1 | 0 | – | SS | Status Update - Message buffer status update. Update of status flags, the slot status field, and the header index. Note: The slot status field of the commit side is updated too, even if the application has locked the commit side. |

22.6.6.4.3 Message Buffer Transitions

Application Transitions

The application transitions that can be triggered by the application using the commands described in [Table 22-109](#). The application issues the commands by writing to the [Message Buffer Configuration, Control, Status Registers \(MBCCSRn\)](#). Only one command can be issued with one write access. Each command is executed immediately. If the command is ignored, it must be issued again.

Message Buffer Enable and Disable

The enable and disable commands can be issued on the transmit side only. Any enable or disable command issued on the commit side will be ignored without notification. The transitions that will be triggered depends on the value of the EDS bit. The enable and disable commands will affect both the commit side and the transmit side at the same time. If the application triggers the disable transition HD while the transmit side is in one of the states CCSa, CCSaCCITx, CCNf, CCNfCCITx, CCMa, CCMaCCITx, CCTx, or CCSu, the disable transition has no effect (command is ignored) and the message buffer state is not changed. No notification is given to the application.

Message Buffer Lock and Unlock

The lock and unlock commands can be issued on the commit side only. Any lock or unlock command issued on the transmit side will be ignored and the double transmit buffer lock error flag DBL_EF in the [CHI Error Flag Register \(CHIERFR\)](#) will be set. The transitions that will be triggered depends on the current value of the LCKS bit. The lock and unlock commands will only affect the commit side. If the application triggers the lock transition HL while the commit side is in the state CCITx, the message buffer state will not be changed and the message buffer lock error flag LCK_EF in the [CHI Error Flag Register \(CHIERFR\)](#) will be set.

Table 22-109. Double Transmit Message Buffer Host Transitions

| Transition | Host Command | Condition | Description |
|------------|----------------------|-----------------------|--|
| HE | MBCCSR(2n+1)[EDT]:=1 | MBCCSR(2n+1)[EDS] = 0 | Application triggers message buffer enable. |
| HD | | MBCCSR(2n+1)[EDS] = 1 | Application triggers message buffer disable. |
| HL | MBCCSR(2n)[LCKT]:=1 | MBCCSR(2n)[LCKS] = 0 | Application triggers message buffer lock. |
| HU | | MBCCSR(2n)[LCKS] = 1 | Application triggers message buffer unlock. |

Module Transitions

The module transitions that can be triggered by the controller are described in [Table 22-110](#). The transitions C1 and C2 apply to both sides of the message buffer and are applied at the same time. All other controller transitions apply to the transmit side only.

Table 22-110. Double Transmit Message Buffer Module Transitions

| Transition | Condition | Description |
|------------------------------------|---|--|
| common transitions | | |
| IS | see Section 22.6.6.4.5 , Internal Message Transfer | Internal Message Transfer Start - Start transfer of message data from commit side to transmit side. |
| IE | | Internal Message Transfer End - Stop transfer of message data from commit side to transmit side. Note: The internal message transfer is stopped before the slot or segment start. |
| transmit side specific transitions | | |
| SA | slot match and static slot | Slot Assigned - Message buffer is assigned to next static slot. |
| MA | slot match and CycleCounter match | Message Available - Message buffer is assigned to next slot and cycle counter filter matches. |
| TX | slot start and $MBCCSR(2n+1)[CMT]=1$ | Transmission Slot Start - Slot Start and commit bit CMT is set. In case of a dynamic slot, pLatestTx is not exceeded. |
| SU | status updated | Status Updated - Slot Status field and message buffer status flags updated. Interrupt flag set. |
| STS | static slot start | Static Slot Start - Start of static slot. |
| DSS | dynamic slot start or symbol window start or NIT start | Dynamic Slot or Segment Start . - Start of dynamic slot or symbol window or NIT. |
| SSS | slot start or symbol window start or NIT start | Slot or Segment Start - Start of static slot or dynamic slot or symbol window or NIT. |

Transition Priorities

The application can trigger only one transition at a time. There is no need to specify priorities among them.

As shown in the first part of [Table 22-111](#), the module transitions have a higher priority than the application transitions. The priorities among the controller transitions and the related states are given in the second part of [Table 22-111](#). These priorities apply only to the transmit side. The internal message transmit start transition IS has the lowest priority.

Table 22-111. Double Transmit Message Buffer Transition Priorities

| State | Priority | Description |
|-------------------------------|----------------------|---|
| module vs. application | | |
| Idle | IS > HD IS > HL | Internal Message Transfer Start > Message Buffer Disable Internal Message Transfer Start > Message Buffer Lock |
| module internal | | |
| Idle | MA > SA | Message Available > Slot Assigned |
| CCMa | TX > STS TX > DSS | Transmission Slot Start > Static Slot Start Transmission Slot Start > Dynamic Slot Start |

22.6.6.4.4 Message Preparation

The application provides the message data through the commit side. The transmission itself is executed from the transmit side. The transfer of the message data from the commit side to the transmit side is done by the *Internal Message Transfer*, which is described in [Section 22.6.6.4.5, Internal Message Transfer](#)

To transmit a message over the FlexRay bus, the application writes the message data into the message buffer data field of the commit side and sets the commit bit CMT in the [Message Buffer Configuration, Control, Status Registers \(MBCCSRn\)](#). The physical access to the message buffer data field is described in [Section 22.6.3.1, Individual Message Buffers](#).

As indicated by [Table 22-107](#), the application shall write to the message buffer data field and change the commit bit CMT only if the transmit message buffer is in one of the states HDis, HDisLck, or HLck. The application can change the state of a message buffer if it issues the appropriate commands shown in [Table 22-109](#). The state change is indicated through the MBCCSRn[EDS] and MBCCSRn[LCKS] status bits.

22.6.6.4.5 Internal Message Transfer

The internal message transfer transfers the message data from the commit side to the transmit side. The internal message transfer is implemented as the swapping of the content of the [Message Buffer Index Registers \(MBIDXRn\)](#) of the commit side and the transmit side. After the swapping, the commit side CMT bit is cleared, the commit side interrupt flag MBIF is set, the transmit side CMT bit is set, and the transmit side DVAL bit is cleared.

The conditions and the point in time when the internal message transfer is started are controlled by the message buffer commit mode bit MCM in the [Message Buffer Configuration, Control, Status Registers \(MBCCSRn\)](#). The MCM bit configures the message buffer for either the streaming commit mode or the immediate commit mode. A detailed description is given in [Streaming Commit Mode](#) and [Immediate Commit Mode](#). The Internal Message Transfer is triggered with the transition IS. Both sides of the message buffer enter one of the CCITx states. The internal message transfer is finished with the transition IE.

Streaming Commit Mode

The intention of the streaming commit mode is to ensure that each committed message is transmitted *at least once*. The controller will not start the Internal Message Transfer for a message buffer as long as the message data on the transmit side is not transmitted at least once.

The streaming commit mode is configured by clearing the message buffer commit mode bit MCM in the [Message Buffer Configuration, Control, Status Registers \(MBCCSRn\)](#).

In this mode, the internal message transfer from the commit side to the transmit side is started for a double transmit message buffer when all of the following conditions are fulfilled

1. the commit side is in the Idle state
2. the commit site message data are valid, i.e. MBCCSR(2n)[CMT] = 1
3. the transmit side is in one of the states Idle, CCSa, or CCMa
4. the transmit side contains either no valid message data, i.e. MBCCSR(2n+1)[CMT] = 0 or the message data were transmitted at least once, i.e. MBCCSR(2n+1)[DVAL] = 1

An example of a streaming commit mode state change diagram is given in [Figure 22-134](#). In this example, both the commit and the transmit side do not contain valid message data and the application provides two messages. The message buffer does not match the next slot.

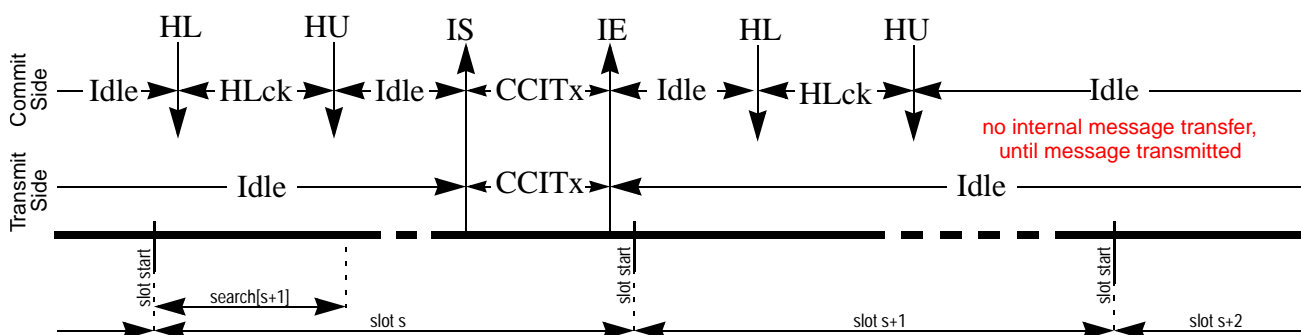

Figure 22-134. Internal Message Transfer in Streaming Commit Mode

Immediate Commit Mode

The intention of the immediate commit mode is to transmit the *latest* data provided by the application. This implies that it is not guaranteed that each provided message will be transmitted at least once.

The immediate commit mode is configured by setting the message buffer commit mode bit MCM in the [Message Buffer Configuration, Control, Status Registers \(MBCCSRn\)](#).

In this mode, the internal message transfer from the commit side to the transmit side is started for one double transmit message buffer when all of the following conditions are fulfilled

1. the commit side is in the Idle state
2. the commit site message data are valid, i.e. $MBCCSR(2n)[CMT] = 1$
3. the transmit side is in one of the states Idle, CCSa, or CCMa

It is not checked whether the transmit side contains no valid message data or valid message data were transmitted at least once. If message data are valid and not transmitted, they may be overwritten.

An example of a streaming commit mode state change diagram is given in [Figure 22-135](#). In this example, both the commit and the transmit side do not contain valid message data, and the application provides two messages and the first message is gets overwritten. The message buffer does not match the next slot.

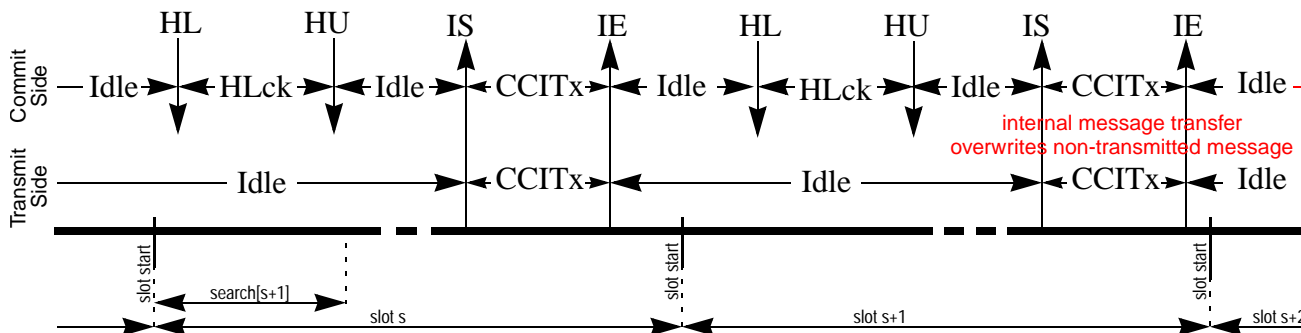

Figure 22-135. Internal Message Transfer in Immediate Commit Mode

22.6.6.4.6 Message Transmission

For double transmit message buffers, the message buffer search checks only the transmit side part. The internal scheduling ensures, that the internal message transfer is stopped on the message buffer search start. Thus, the transmit side of message buffer, that is not in its transmission or status update slot, is always in the Idle state.

The message transmit behavior and transmission state changes of the transmit side of a double transmit message buffer are the same as for single buffered transmit buffers, except that the transmit side of double buffers can not be locked by the application, i.e. the HU and HL transition do not exist. Therefore, refer to [Section 22.6.6.2.5, Message Transmission](#).

22.6.6.4.7 Message Buffer Status Update

The message buffer status update behavior of the transmit side of a double transmit message buffer is the same as for single transmit message buffers which is described in [Section 22.6.6.2.7, Message Buffer Status Update](#).

Additionally, the slot status field of the commit side is update after the update of the slot status field of the transmit side, even if the commit side is locked by the application. This is implemented to provide the slot status of the most recent transmission slot.

22.6.7 Individual Message Buffer Search

This section provides a detailed description of the message buffer search algorithm.

The message buffer search determines for each enabled channel if a slot s in a communication cycle c is assigned for frame or null frame transmission or if it is subscribed for frame reception on that channel.

The message buffer search is a sequential algorithm which is invoked at the following protocol related events:

1. NIT start
2. slot start in the static segment
3. minislot start in the dynamic segment

The message buffer search within the NIT searches for message buffers assigned or subscribed to slot 1. The message buffer search within slot n searches for message buffers assigned or subscribed to slot $n+1$.

In general, the message buffer search for the next slot n considers only message buffers which are

1. enabled, i.e. $\text{MBCCSR}_n[\text{EDS}] = 1$, and
2. matches the next slot n , i.e. $\text{MBFIDR}_n[\text{FID}] = n$, and
3. are the transmit side buffer in case of a double transmit message buffer.

On top of that, for the static segment only those message buffers are considered, that match the condition of at least one row of [Table 22-112](#). For the dynamic segment only those message buffers are considered, that match the condition of at least one row of [Table 22-113](#). These message buffers are called *matching* message buffers.

For each enabled channel the message buffer search may identify multiple *matching* message buffers. Among all matching message buffers the message buffers with highest priority according to [Table 22-112](#) for the static segment and according to [Table 22-113](#) for the dynamic segment are selected.

Table 22-112. Message Buffer Search Priority (static segment)

| Priority | MTD | LCKS | CMT | CCFM ¹ | Description | Transition |
|-------------|-----|------|-----|-------------------|--|------------|
| (highest) 0 | 1 | 0 | 1 | 1 | transmit buffer, matches cycle count, not locked and committed | MA |
| 1 | 1 | - | 0 | 1 | transmit buffer, matches cycle count, not committed | SA |
| | 1 | 1 | - | 1 | transmit buffer, matches cycle count, locked | SA |
| 2 | 1 | - | - | - | transmit buffer | SA |
| 3 | 0 | 0 | n/a | 1 | receive buffer, matches cycle count, not locked | SB |
| (lowest) 4 | 0 | 1 | n/a | 1 | receive buffer, matches cycle count, locked | SB |

¹ Cycle Counter Filter Match, see [Section 22.6.7.1, Message Buffer Cycle Counter Filtering](#).

Table 22-113. Message Buffer Search Priority (dynamic segment)

| Priority | MTD | LCKS | CMT | CCFM ¹ | Description | Transition |
|-------------|-----|------|-----|-------------------|--|------------|
| (highest) 0 | 1 | 0 | 1 | 1 | transmit buffer, matches cycle count, not locked and committed | MA |
| 1 | 0 | 0 | n/a | 1 | receive buffer, matches cycle count, not locked | SB |
| (lowest) 2 | 0 | 1 | n/a | 1 | receive buffer, matches cycle count, locked | SB |

¹ Cycle Counter Filter Match, see [Section 22.6.7.1, Message Buffer Cycle Counter Filtering](#).

If there are multiple message buffer with highest priority, the message buffer with the lowest message buffer number is selected. All message buffer which have the highest priority must have a consistent channel assignment as specified in [Section 22.6.7.2, Message Buffer Channel Assignment Consistency](#).

Depending on the message buffer channel assignment the same message buffer can be found for both channel A and channel B. In this case, this message buffer is used as described in [Section 22.6.3.1, Individual Message Buffers](#).

22.6.7.1 Message Buffer Cycle Counter Filtering

The message buffer cycle counter filter is a value-mask filter defined by the CCFE, CCFMSK, and CCFVAL fields in the [Message Buffer Cycle Counter Filter Registers \(MBCCFRn\)](#). This filter determines a set of communication cycles in which the message buffer is considered for message reception or message transmission. If the cycle counter filter is disabled, i.e. CCFE = 0, this set of cycles consists of all communication cycles.

If the cycle counter filter of a message buffer does not match a certain communication cycle number, this message buffer is not considered for message transmission or reception in that communication cycle. In case of a transmit message buffer assigned to a slot in the static segment, though, this buffer is added to the matching message buffers to indicate the slot assignment and to trigger the null frame transmission.

The cycle counter filter of a message buffer matches the communication cycle with the number CYCCNT if at least one of the following conditions evaluates to true:

$$MBCCFR_n[CCFE] = 0 \quad \text{Eqn. 22-12}$$

$$CYCCNT \& MBCCFR_n[CCFMSK] = MBCCFR_n[CCFVAL] \& MBCCFR_n[CCFMSK] \quad \text{Eqn. 22-13}$$

22.6.7.2 Message Buffer Channel Assignment Consistency

The message buffer channel assignment given by the CHA and CHB bits in the [Message Buffer Cycle Counter Filter Registers \(MBCCFR_n\)](#) defines the channels on which the message buffer will receive or transmit. The message buffer with number *n* transmits or receives on channel A if MBCCFR_n[CHA] = 1 and transmits or receives on channel B if MBCCFR_n[CHB] = 1.

To ensure correct message buffer operation, all message buffers assigned to the same slot and with the same priority must have a *consistent* channel assignment. That means they must be either assigned to one channel only, or must be assigned to *both* channels. The behavior of the message buffer search is not defined, if both types of channel assignments occur for one slot and priority. An inconsistent channel assignment for message buffer 0 and message buffer 1 is depicted in [Figure 22-136](#).

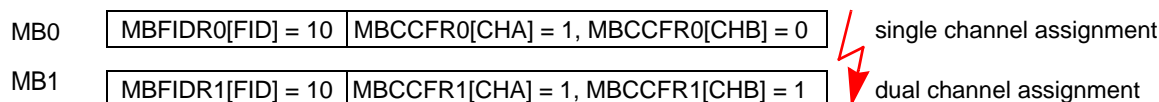

Figure 22-136. Inconsistent Channel Assignment

22.6.7.3 Node Related Slot Multiplexing

The term *Node Related Slot Multiplexing* applies to the dynamic segment only and refers to the functionality if there are transmit as well as receive message buffers are configured for the same slot.

According to [Table 22-113](#) the transmit buffer is only found if the cycle counter filter matches, and the buffer is not locked and committed. In all other cases, the receive buffer will be found. Thus, if the block has no data to transmit in a dynamic slot, it is able to receive frames on that slot.

22.6.7.4 Message Buffer Search Error

If the message buffer search is running while the next message buffer search start event appears, the message buffer search is stopped and the Message Buffer Search Error Flag MSB_EF is set in the [CHI Error Flag Register \(CHIERFR\)](#). This appears only if the CHI frequency is too low to search through all message buffers within the NIT or a minislot. The message buffer result is not defined in this case. For more details see [Section 22.7.3, Number of Usable Message Buffers](#).

22.6.8 Individual Message Buffer Reconfiguration

The initial configuration of each individual message buffer can be changed even when the protocol is not in the *POC:config* state. This is referred to as individual message buffer *reconfiguration*. The configuration bits and fields that can be changed are given in the section on [Specific Configuration Data](#).

The common configuration data given in the section on [Specific Configuration Data](#) can not be reconfigured when the protocol is out of the *POC:config* state.

22.6.8.1 Reconfiguration Schemes

Depending on the target and destination basic state of the message buffer that is to be reconfigured, there are three reconfiguration schemes.

22.6.8.1.1 Basic Type Not Changed (RC1)

A reconfiguration will not change the basic type of the individual message buffer, if both the message buffer transfer direction bit MBCCSn[MTD] and the message buffer type bit MBCCSn[MBT] are not changed. This type of reconfiguration is denoted by RC1 in [Figure 22-137](#). Single transmit and receive message buffers can be RC1-reconfigured when in the HDis or HDisLck state. Double transmit message buffers can be RC1-reconfigured if both the transmit side and the commit side are in the HDis state.

22.6.8.1.2 Buffer Type Not Changed (RC2)

A reconfiguration will not change the buffer type of the individual message buffer if the message buffer type bit MBCCSRn[MBT] is not changed. This type of reconfiguration is denoted by RC2 in [Figure 22-137](#). It applies only to single transmit and receive message buffers. Single transmit and receive message buffers can be RC2-reconfigured when in the HDis or HDisLck state.

22.6.8.1.3 Buffer Type Changed (RC3)

A reconfiguration will change the buffer type of the individual message buffer if the message buffer type bit MBCCSRn[MBT] is changed. This type of reconfiguration is denoted by RC3 in [Figure 22-137](#). The RC3 reconfiguration splits one double buffer into two single buffers or combines two single buffer into one double buffer. In the later case, the two single message buffers must have consecutive message buffer numbers and the smaller one must be even. Message Buffers can be RC3 reconfigured if they are in the HDis state.

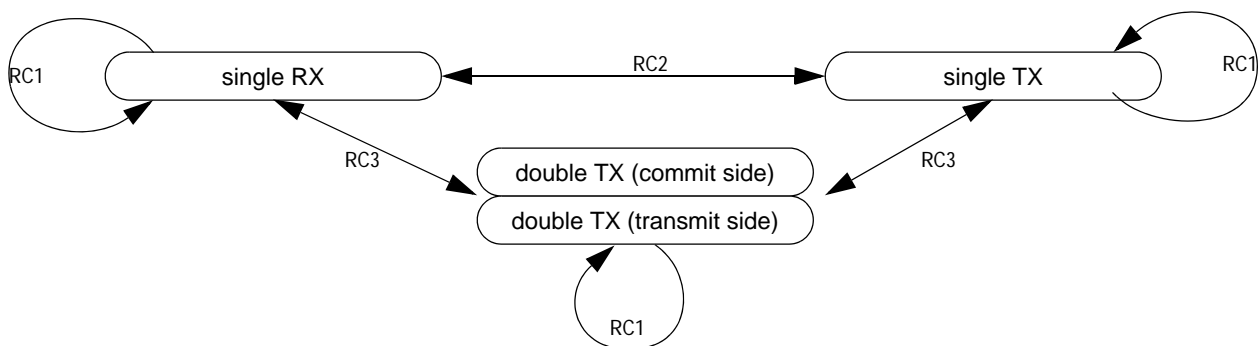

Figure 22-137. Message Buffer Reconfiguration Scheme

22.6.9 Receive FIFOs

This section provides the functional description of the two receive FIFOs.

22.6.9.1 Overview

The two receive FIFOs implement the queued message buffer concept defined by the *FlexRay Communications System Protocol Specification, Version 2.1 Rev A*. One FIFO is assigned to channel A, the other FIFO is assigned to channel B. Both FIFOs work completely independent from each other.

The message buffer structure of each FIFO is described in [Section 22.6.3.3, Receive FIFO](#). The area in the flexray memory for each of the two FIFOs is characterized by:

- The FIFO system memory base address
- The index of the first FIFO entry given by [Receive FIFO Start Index Register \(RFSIR\)](#)
- The number of FIFO entries and the length of each FIFO entry as given by [Receive FIFO Depth and Size Register \(RFDSR\)](#)

22.6.9.2 FIFO Configuration

The FIFOs can be configured for two different locations of the system memory base address via the FIFO address mode bit FAM in the [Module Configuration Register \(MCR\)](#).

22.6.9.2.1 Single System Memory Base Address Mode

This mode is configured, when the FIFO address mode flag MCR[FAM] is set to 0. In this mode, the location of the system memory base address for the FIFO buffers is [System Memory Base Address Register \(SYMBADR\)](#).

22.6.9.2.2 Dual System Memory Base Address Mode

This mode is configured, when the FIFO address mode flag MCR[FAM] is set to 1. In this mode, the location of the system memory base address for the FIFO buffers is [Receive FIFO System Memory Base Address Register \(RFSYMBADR\)](#).

The FIFO control and configuration data are given in [Section 22.6.3.7, Receive FIFO Control and Configuration Data](#). The configuration of the FIFOs consists of two steps.

The first step is the allocation of the required amount of flexray memory for the FlexRay window. This includes the allocation of the message buffer header area and the allocation of the message buffer data fields. For more details see [Section 22.6.4, FlexRay Memory Layout](#).

The second step is the programming of the configuration data register while the PE is in *POC:config*.

The following steps configure the layout of the FIFO.

- Configure the FIFO update and address modes in [Module Configuration Register \(MCR\)](#)
- Configure the FIFO system memory base address
- Configure the [Receive FIFO Start Index Register \(RFSIR\)](#) with the first message buffer header index that belongs to the FIFO
- Configure the [Receive FIFO Depth and Size Register \(RFDSR\)](#) with FIFO entry size
- Configure the [Receive FIFO Depth and Size Register \(RFDSR\)](#) with FIFO depth
- Configure the FIFO Filters

22.6.9.3 FIFO Periodic Timer

The FIFO periodic timer is used to generate an FIFO almost-full interrupt at certain point in time, if the almost-full watermark is not reached, but the FIFO is not empty. This can be used to prevent frames from get stuck in the FIFO for a long time.

The FIFO periodic timer is configured via the [Receive FIFO Periodic Timer Register \(RFPTR\)](#). If the periodic timer duration $RFPTIR[PTD]$ is configured to $0x0000$, the periodic timer is continuously expired. If the periodic timer duration $RFPTIR[PTD]$ is configured to $0x3FFF$, the periodic timer never expires. If the periodic timer is configured to a value ptd , greater than $0x0000$ and smaller $0x3FFF$, the periodic timer expires and is restarted at the start of every communication cycle, and expires and is restarted after ptd macroticks have been elapsed.

22.6.9.4 FIFO Reception

The FIFO reception is a controller internal operation.

A message frame reception is directed into the FIFO, if no individual message buffer is assigned for transmission or subscribed for reception for the current slot. In this case the FIFO filter path shown in [Figure 22-138](#) is activated.

If the FIFO filter path indicates that the received frame has to be appended to the FIFO and the FIFO is not full, the controller writes the received frame header into the message buffer header field indicated by the controller internal FIFO write index. The frame payload data are written into the corresponding message buffer data field. If the status of the received frame indicates a valid non-null frame, the slot status information is written into the message buffer header field and the controller internal FIFO write index is updated by 1 and the fifo fill level FLA (FLB) in the [Receive FIFO Fill Level and POP Count Register \(RFFLPCR\)](#) is incremented. If the status of the received frame indicates an invalid or null frame, the frame is not appended to the FIFO.

22.6.9.5 FIFO Almost-Full Interrupt Generation

If the fifo fill level FLA (FLB) is updated after a frame reception and exceeds the FIFO watermark level WM , i.e. $FLA > WM_A$ ($FLB > WM_B$), then the FIFO almost-full interrupt flag $GIFER[FAFAIF]$ ($GIFER[FAFBIF]$) is asserted. If the periodic timer expires, and $FIFOA$ ($FIFOB$) is not empty, i.e. $FLA > 0$ ($FLB > 0$), then the FIFO almost-full interrupt flag $GIFER[FAFAIF]$ ($GIFER[FAFBIF]$) is asserted.

22.6.9.6 FIFO Overflow Error Generation

If the $FIFOA$ ($FIFOB$) is full, i.e. $FLA = FIFO_DEPTH_A$ ($FLB = FIFO_DEPTH_B$) and the conditions for a FIFO reception as described in [Section 22.6.9.4, FIFO Reception](#), are fulfilled, then the fifo overflow error flag $CHIERFR[FOVA_EF]$ ($CHIERFR[FOVB_EF]$) is asserted.

22.6.9.7 FIFO Message Access

The $FIFOA$ ($FIFOB$) contains valid messages if the FIFO fill level FLA (FLB) is greater than 0. The [Receive FIFO A Read Index Register \(RFARIR\)](#) ([Receive FIFO B Read Index Register \(RFBRIR\)](#)) pointing to a message buffer with valid content and the oldest frames stored in the FIFO.

If the FIFO fill level FLA (FLB) is 0, then the FIFOA (FIFOB) contains no valid messages and the [Receive FIFO A Read Index Register \(RFARIR\)](#) ([Receive FIFO B Read Index Register \(RFBRIR\)](#)) pointing to a message buffer with invalid content. In this case the application must not read data from the FIFO.

To access the oldest message in the FIFOA (FIFOB), the application first reads the read index RDIDX out of the [Receive FIFO A Read Index Register \(RFARIR\)](#) ([Receive FIFO B Read Index Register \(RFBRIR\)](#)). This read index points to the message buffer header field of the oldest message buffer that contains valid received message data. The application can access the message data as described in [Section 22.6.3.3, Receive FIFO](#). When the application has read the message buffer data and status information, it can update the FIFO as described in [Section 22.6.9.8, FIFO Update](#).

22.6.9.8 FIFO Update

The application updates the FIFOA (FIFOB) by writing a pop count value pc different from 0 to the PCA (PCB) field in the [Receive FIFO Fill Level and POP Count Register \(RFFLPCR\)](#).

As a result of this operation, the controller removes the oldest pc entries from FIFOA (FIFOB).

If the specified pop count value pc is greater than the current fill level fl provided in FLA (FAB) field, then only fl entries are removed from the FIFOA (FIFOB), the remaining $fl-pc$ requested pop operations are discarded without any notification. In this case FIFOA (FIFOB) is empty after the update operation.

The read index in the [Receive FIFO A Read Index Register \(RFARIR\)](#) ([Receive FIFO B Read Index Register \(RFBRIR\)](#)) is incremented by the number of removed items. If the read index reaches the top of the FIFO, it wraps around to the FIFO start index defined in [Receive FIFO Start Index Register \(RFSIR\)](#) automatically.

22.6.9.8.1 FIFO Interrupt Flag Update

When the FIFO Interrupt Flag Update mode is configured, when the FIFO update mode flag MCR[FUM] is set to 0. In this mode FIFOA (FIFOB) will be updated by 1 entry, when the interrupt flag GIFER[FAFAIF] (GIFER[FAFBIF]) is written with 1 by the application.

If the FIFO is empty, the update request is ignored without any notification.

The read index in the [Receive FIFO A Read Index Register \(RFARIR\)](#) ([Receive FIFO B Read Index Register \(RFBRIR\)](#)) is incremented by 1, if the FIFO was not empty. If the read index reaches the top of the FIFO, it wraps around to the FIFO start index automatically.

22.6.9.9 FIFO Filtering

The FIFO filtering is activated after all enabled individual receive message buffers have been searched without success for a message buffer to receive the current frame.

The controller provides three sets of FIFO filters. The FIFO filters are applied to valid non-null frames only. The FIFO will not receive invalid or null-frames. For each FIFO filter, the pass criteria is specified in the related section given below. Only frames that have passed all filters will be appended to the FIFO. The FIFO filter path is depicted in [Figure 22-138](#).

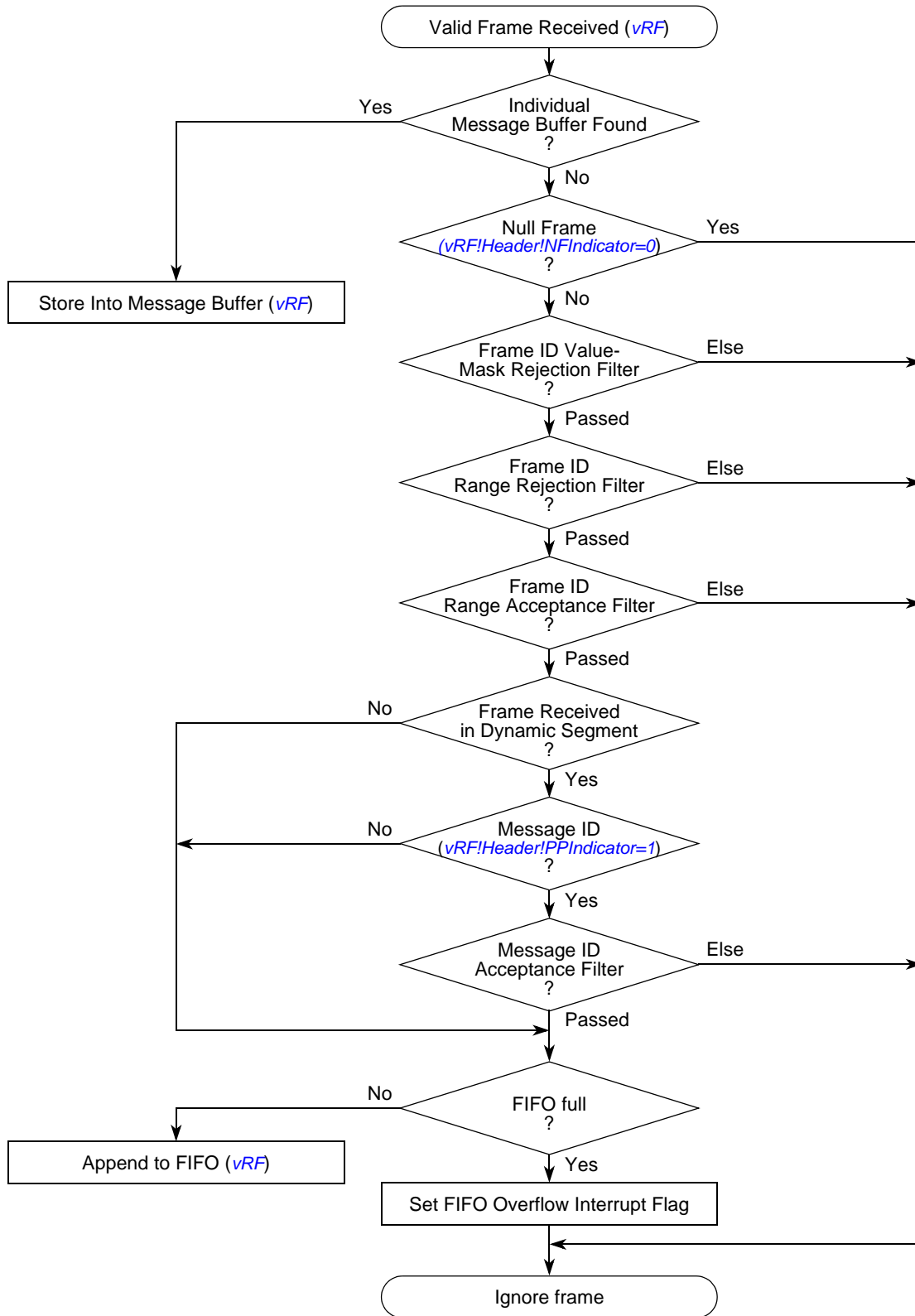

Figure 22-138. Received Frame FIFO Filter Path

A received frame passes the FIFO filtering if it has passed all three type of filter.

22.6.9.9.1 RX FIFO Frame ID Value-Mask Rejection Filter

The frame ID value-mask rejection filter is a value-mask filter and is defined by the fields in the [Receive FIFO Frame ID Rejection Filter Value Register \(RFFIDRFVR\)](#) and the [Receive FIFO Frame ID Rejection Filter Mask Register \(RFFIDRFMR\)](#). Each received frame with a frame ID FID that does not match the value-mask filter value passes the filter, i.e. is not rejected.

Consequently, a received valid frame with the frame ID FID passes the RX FIFO Frame ID Value-Mask Rejection Filter if [Equation 22-14](#) is fulfilled.

$$ID \& RFFIDRFMR[FIDRFMSK] \neq RFFIDRFVR[FIDRFVAL] \& RFFIDRFMR[FIDRFMSK] \quad \text{Eqn. 22-14}$$

The RX FIFO Frame ID Value-Mask Rejection Filter can be configured to pass all frames by the following settings.

- RFFIDRFVR[FIDRFVAL]:= 0x000 and RFFIDRFMR[FIDRFMSK]:= 0x7FF

Using the settings above, only the frame with frame ID 0 will be rejected, which is an invalid frame. All other frames will pass.

The RX FIFO Frame ID Value-Mask Rejection Filter can be configured to reject all frames by the following settings.

- RFFIDRFMR[FIDRFMSK]:= 0x000

Using the settings above, [Equation 22-14](#) can never be fulfilled ($0 \neq 0$) and thus all frames are rejected; no frame will pass. This is the reset value for the RX FIFO.

22.6.9.9.2 RX FIFO Frame ID Range Rejection Filter

Each of the four RX FIFO Frame ID Range filters can be configured as a rejection filter. The filters are configured by the [Receive FIFO Range Filter Configuration Register \(RFRFCFR\)](#) and controlled by the [Receive FIFO Range Filter Control Register \(RFRFCTR\)](#). The RX FIFO Frame ID range filters apply to all received valid frames. A received frame with the frame ID FID passes the RX FIFO Frame ID Range rejection filters if either no rejection filter is enabled, or, for all of the enabled RX FIFO Frame ID Range rejection filters, i.e. $RFRFCTR.FiMD = 1$ and $RFRFCTR.FiEN = 1$, [Equation 22-15](#) is fulfilled.

$$FID < RFRFCFR_{SEL}[SID_{IBD=0}] \text{ or } (RFRFCFR_{SEL}[SID_{IBD=1}] < FID) \quad \text{Eqn. 22-15}$$

Consequently, all frames with a frame ID that fulfills [Equation 22-16](#) for at least one of the enabled rejection filters will be rejected and thus not pass.

$$\exists RFRFCFR_{SEL}[SID_{IBD=0}] \leq FID \leq RFRFCFR_{SEL}[SID_{IBD=1}] \quad \text{Eqn. 22-16}$$

22.6.9.9.3 RX FIFO Frame ID Range Acceptance filter

Each of the four RX FIFO Frame ID Range filters can be configured as an acceptance filter. The filters are configured by the [Receive FIFO Range Filter Configuration Register \(RFRFCFR\)](#) and controlled by the [Receive FIFO Range Filter Control Register \(RFRFCTR\)](#). The RX FIFO Frame ID range filters apply to all received valid frames. A received frame with the frame ID FID passes the RX FIFO Frame ID Range

acceptance filters if either no acceptance filter is enabled, or, for at least one of the enabled RX FIFO Frame ID Range acceptance filters, i.e. $RFRFCR.FiMD = 0$ and $RFRFCR.FiEN = 1$, [Equation 22-17](#) is fulfilled.

$$\{RFRFCR_{SEL}[SID_{IBD=0}] \leq FID \leq RFRFCR_{SEL}[SID_{IBD=1}]\} \quad \text{Eqn. 22-17}$$

22.6.9.9.4 RX FIFO Message ID Acceptance Filter

The RX FIFO Message ID Acceptance Filter is a value-mask filter and is defined by the [Receive FIFO Message ID Acceptance Filter Value Register \(RFMIDAFVR\)](#) and the [Receive FIFO Message ID Acceptance Filter Mask Register \(RFMIAFMR\)](#). This filter applies only to valid frames received in the dynamic segment with the payload preamble indicator bit PPI set to 1. All other frames will pass this filter.

A received valid frame in the dynamic segment with the payload preamble indicator bit PPI set to 1 and with the message ID MID (the first two bytes of the payload) will pass the RX FIFO Message ID Acceptance Filter if [Equation 22-18](#) is fulfilled.

$$MID \& RFMIDAFMR[MIDAFMSK] = RFMIDAFMR[MIDAFVAL] \& RFMIDAFMR[MIDAFMSK] \quad \text{Eqn. 22-18}$$

The RX FIFO Message ID Acceptance Filter can be configured to accept all frames by setting

- $RFMIDAFMR[MIDAFMSK] := 0x000$

Using the settings above, [Equation 22-18](#) is always fulfilled and all frames will pass.

22.6.10 Channel Device Modes

This section describes the two FlexRay channel device modes that are supported by the controller.

22.6.10.1 Dual Channel Device Mode

In the dual channel device mode, both FlexRay ports are connected to physical FlexRay bus lines. The FlexRay port consisting of FR_A_RX , FR_A_TX , and $\overline{FR_A_TX_EN}$ is connected to the physical bus channel A and the FlexRay port consisting of FR_B_RX , FR_B_TX , and $\overline{FR_B_TX_EN}$ is connected to the physical bus channel B. The dual channel system is shown in [Figure 22-139](#).

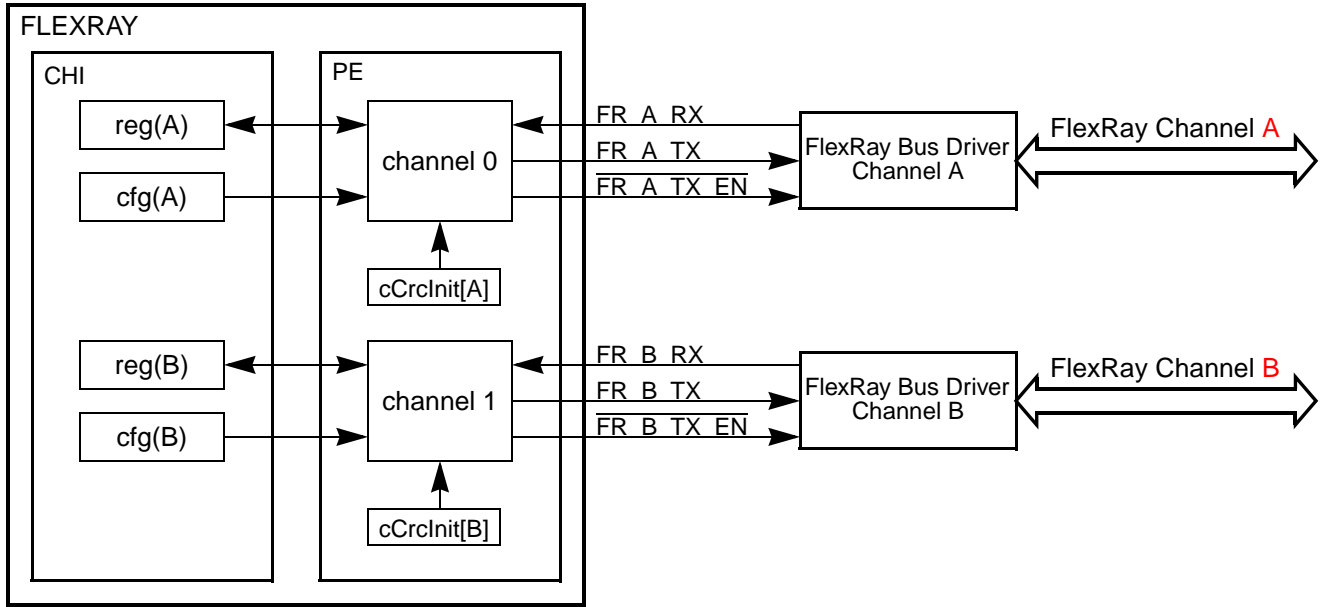

Figure 22-139. Dual Channel Device Mode

22.6.10.2 Single Channel Device Mode

The single channel device mode supports devices that have only one FlexRay port available. This FlexRay port consists of the signals FR_A_RX, FR_A_TX, and $\overline{\text{FR_A_TX_EN}}$ and can be connected to either the physical bus channel A (shown in Figure 22-140) or the physical bus channel B (shown in Figure 22-141).

If the device is configured as a single channel device by setting MCR.SCD to 1, only the internal channel A and the FlexRay Port A is used. Depending on the setting of MCR.CHA and MCR.CHB, the internal channel A behaves either as a FlexRay Channel A or FlexRay Channel B. The bit MCR.CHA must be set, if the FlexRay Port A is connected to a FlexRay Channel A. The bit MCR.CHB must be set if the FlexRay Port A is connected to a FlexRay Channel B. The two FlexRay channels differ only in the initial value for the frame CRC *cCrclnit*. For a single channel device, the application can access and configure only the registers related to internal channel A.

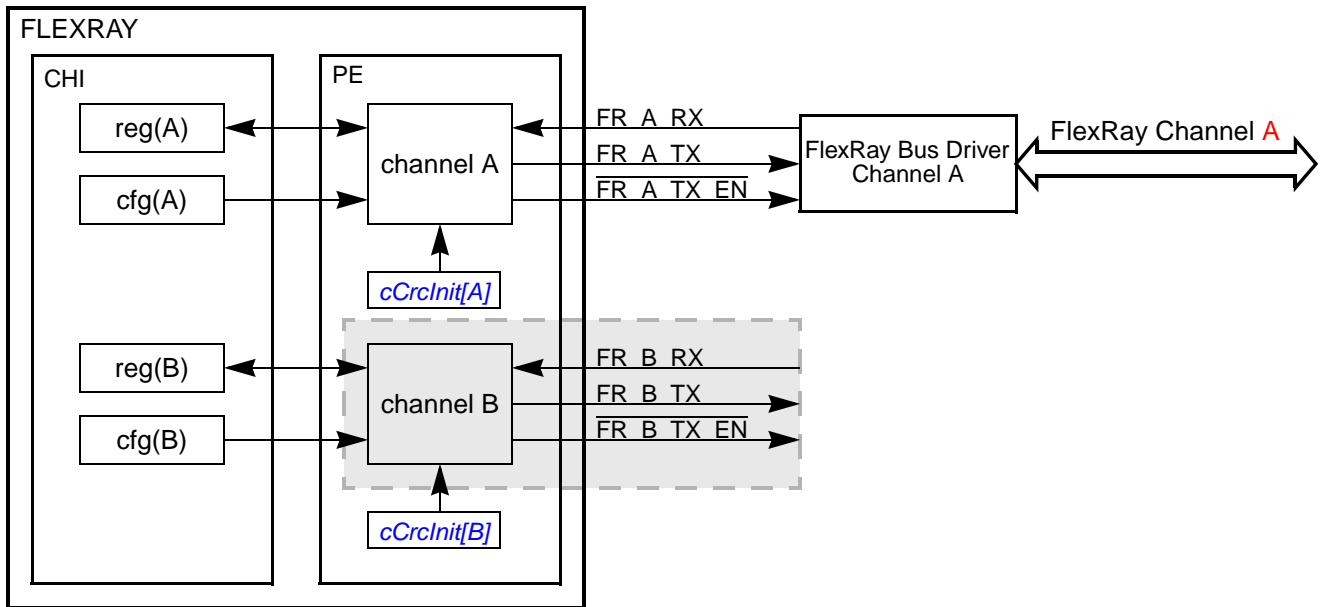

Figure 22-140. Single Channel Device Mode (Channel A)

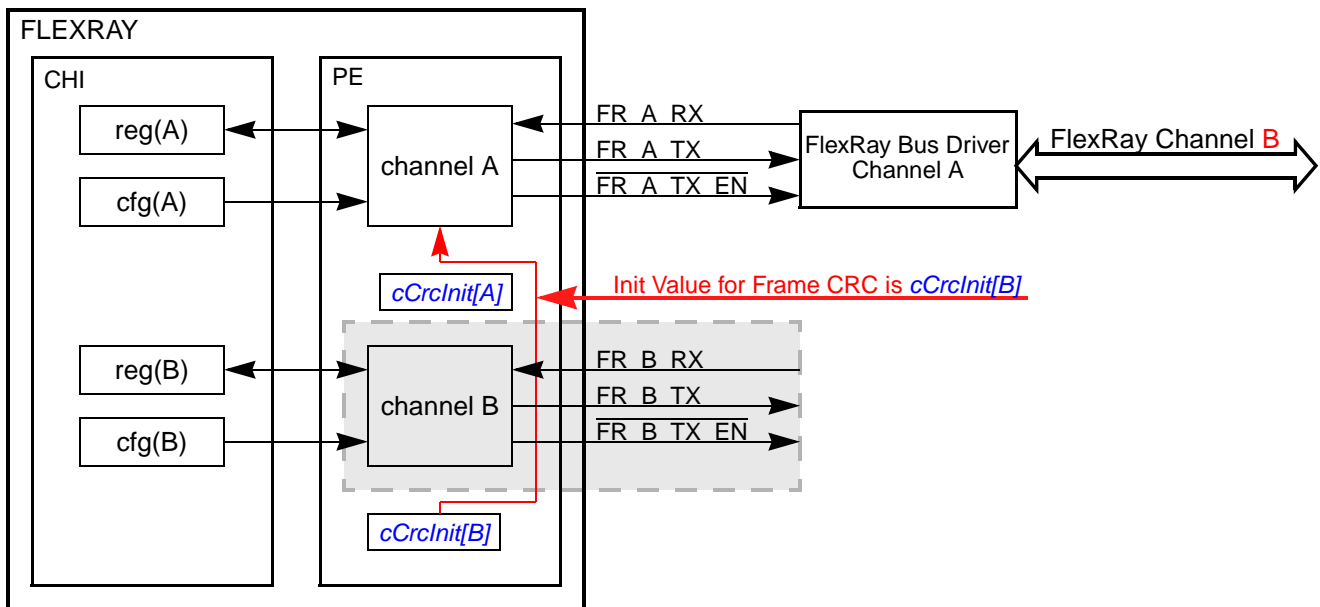

Figure 22-141. Single Channel Device Mode (Channel B)

22.6.11 External Clock Synchronization

The application of the external rate and offset correction is triggered when the application writes to the EOC_AP and ERC_AP fields in the [Protocol Operation Control Register \(POCR\)](#). The PE applies the external correction values in the next even-odd cycle pair as shown in [Figure 22-142](#) and [Figure 22-143](#).

NOTE

The values provided in the EOC_AP and ERC_AP fields are the values that were written from the application most recently. If these value were already applied, they will not be applied in the current cycle pair again.

If the offset correction applied in the NIT of cycle $2n+1$ shall be affect by the external offset correction, the EOC_AP field must be written to after the start of cycle $2n$ and before the end of the static segment of cycle $2n+1$. If this field is written to after the end of the static segment of cycle $2n+1$, it is not guaranteed that the external correction value is applied in cycle $2n+1$. If the value is not applied in cycle $2n+1$, then the value will be applied in the cycle $2n+3$. Refer to [Figure 22-142](#) for timing details.

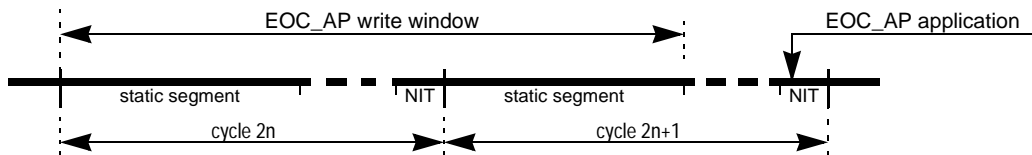

Figure 22-142. External Offset Correction Write and Application Timing

If the rate correction for the cycle pair $[2n+2, 2n+3]$ shall be affect by the external offset correction, the ERC_AP field must be written to after the start of cycle $2n$ and before the end of the static segment start of cycle $2n+1$. If this field is written to after the end of the static segment of cycle $2n+1$, it is not guaranteed that the external correction value is applied in cycle pair $[2n+2, 2n+3]$. If the value is not applied for cycle pair $[2n+2, 2n+3]$, then the value will be applied for cycle pair $[2n+4, 2n+5]$. Refer to [Figure 22-143](#) for details.

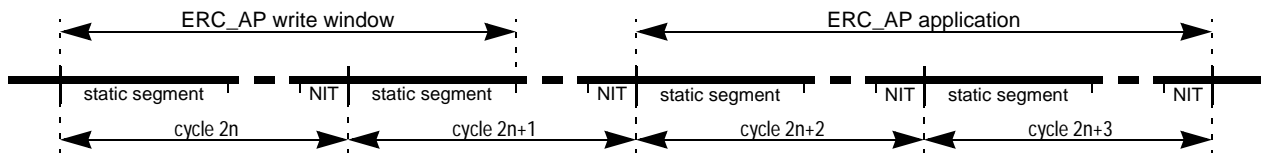

Figure 22-143. External Rate Correction Write and Application Timing

22.6.12 Sync Frame ID and Sync Frame Deviation Tables

The FlexRay protocol requires the provision of a snapshot of the Synchronization Frame ID tables for the even and odd communication cycle for both channels. The controller provides the means to write a copy of these internal tables into the flexray memory and ensures application access to consistent tables by means of table locking. Once the application has locked the table successfully, the controller will not overwrite these tables and the application can read a consistent snapshot.

NOTE

Only synchronization frames that have passed the synchronization frame filters are considered for clock synchronization and appear in the sync frame tables.

22.6.12.1 Sync Frame ID Table Content

The Sync Frame ID Table is a snapshot of the protocol related variables *vsSyncIdListA* and *vsSyncIdListB* for each even and odd communication cycle. This table provides a list of the frame IDs of the synchronization frames received on the corresponding channel and cycle that are used for the clock synchronization.

22.6.12.2 Sync Frame Deviation Table Content

The Sync Frame Deviation Table is a snapshot of the protocol related variable *zsDev(id)(oe)(ch)!Value*. Each Sync Frame Deviation Table entry provides the deviation value for the sync frame, with the frame ID presented in the corresponding entry in the Sync Frame ID Table.

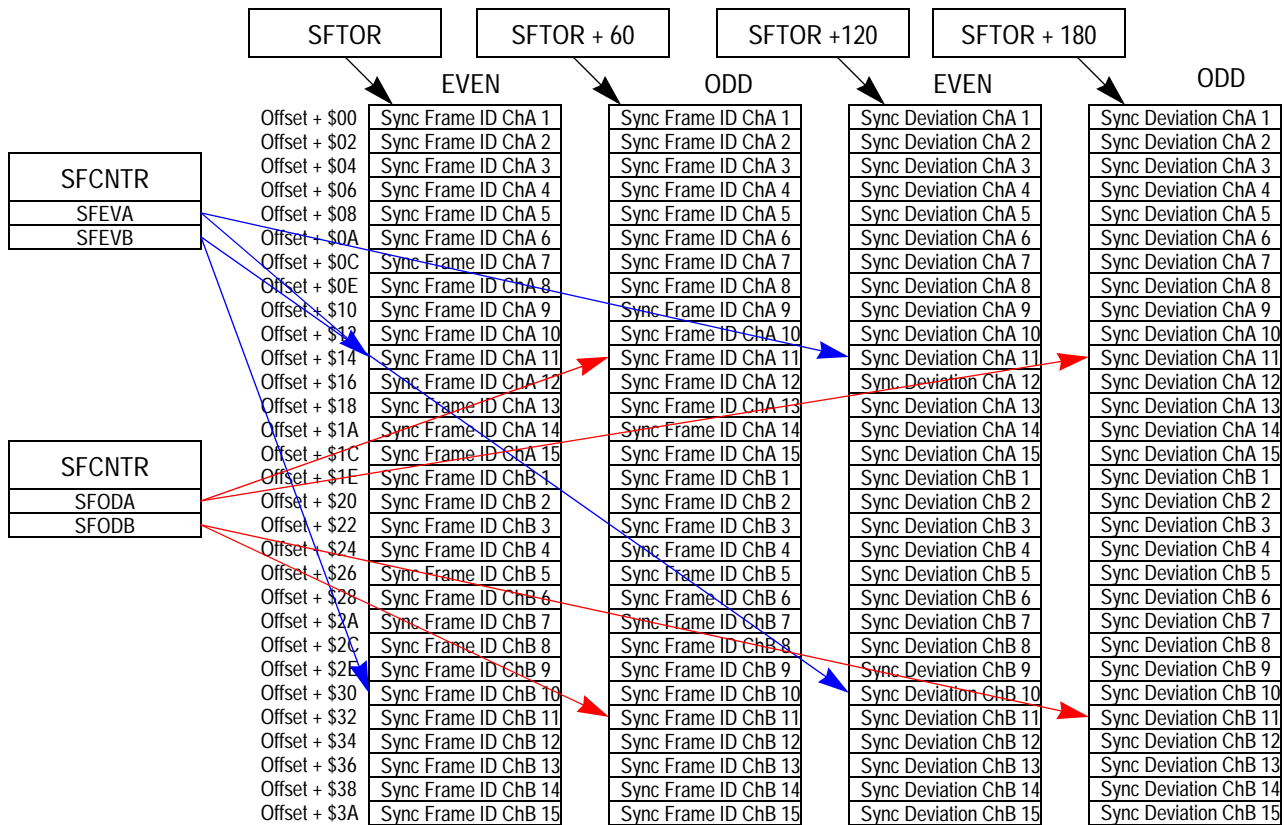

Figure 22-144. Sync Table Memory Layout

22.6.12.3 Sync Frame ID and Sync Frame Deviation Table Setup

The controller writes a copy of the internal synchronization frame ID and deviation tables into the flexray memory if requested by the application. The application must provide the appropriate amount of flexray memory for the tables. The memory layout of the tables is given in Figure 22-144. Each table occupies 120 16-bit entries.

While the protocol is in *POC:config* state, the application must program the offsets for the tables into the [Sync Frame Table Offset Register \(SFTOR\)](#).

22.6.12.4 Sync Frame ID and Sync Frame Deviation Table Generation

The application controls the generation process of the Sync Frame ID and Sync Frame Deviation Tables into the flexray memory using the [Sync Frame Table Configuration, Control, Status Register \(SFTCCSR\)](#). A summary of the copy modes is given in [Table 22-114](#).

Table 22-114. Sync Frame Table Generation Modes

| SFTCCSR | | | Description |
|---------|-------|-------|--|
| OPT | SDVEN | SIDEN | |
| 0 | 0 | 0 | No Sync Frame Table copy |
| 0 | 0 | 1 | Sync Frame ID Tables will be copied continuously |
| 0 | 1 | 0 | Reserved |
| 0 | 1 | 1 | Sync Frame ID Tables and Sync Frame Deviation Tables will be copied continuously |
| 1 | 0 | 0 | No Sync Frame Table copy |
| 1 | 0 | 1 | Sync Frame ID Tables for next even-odd-cycle pair will be copied |
| 0 | 1 | 0 | Reserved |
| 1 | 1 | 1 | Sync Frame ID Tables and Sync Frame Deviation Tables for next even-odd-cycle pair will be copied |

The Sync Frame Table generation process is described in the following for the even cycle. The same sequence applies to the odd cycle.

If the application has enabled the sync frame table generation by setting SFTCCSR.SIDEN to 1, the controller starts the update of the even cycle related tables after the start of the NIT of the next even cycle. The controller checks if the application has locked the tables by reading the SFTCCSR.ELKS lock status bit. If this bit is set, the controller will not update the table in this cycle. If this bit is cleared, the controller locks this table and starts the table update. To indicate that these tables are currently updated and may contain inconsistent data, the controller clears the even table valid status bit SFTCCSR[EVAL]. Once all table entries related to the even cycle have been transferred into the flexray memory, the controller sets the even table valid bit SFTCCSR[EVAL] and the Even Cycle Table Written Interrupt Flag EVT_IF in the [Protocol Interrupt Flag Register 1 \(PIFR1\)](#). If the interrupt enable flag EVT_IE is set, an interrupt request is generated.

To read the generated tables, the application must lock the tables to prevent the controller from updating these tables. The locking is initiated by writing a 1 to the even table lock trigger SFTCCSR.ELKT. When the even table is not currently updated by the controller, the lock is granted and the even table lock status bit SFTCCSR.ELKS is set. This indicates that the application has successfully locked the even sync tables and the corresponding status information fields SFRA, SFRB in the [Sync Frame Counter Register \(SFCNTR\)](#). The value in the SFTCCSR.CYCNUM field provides the number of the cycle that this table is related to.

The number of available table entries per channel is provided in the SFCNTR.SFEVA and SFCNTR.SFEVB fields. The application can now start to read the sync table data from the locations given in [Figure 22-144](#).

After reading all the data from the locked tables, the application must unlock the table by writing to the even table lock trigger SFTCCSR.ELKT again. The even table lock status bit SFTCCSR.ELKS is reset immediately.

If the sync frame table generation is disabled, the table valid bits SFTCCSR[EVAL] and SFTCCSR[EVAL] are reset when the counter values in the [Sync Frame Counter Register \(SFCNTR\)](#) are updated. This is done because the tables stored in the flexray memory are no longer related to the values in the [Sync Frame Counter Register \(SFCNTR\)](#).

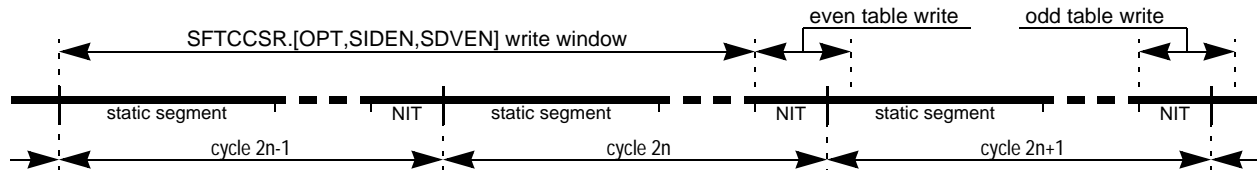

Figure 22-145. Sync Frame Table Trigger and Generation Timing

22.6.12.5 Sync Frame Table Access

The sync frame tables will be transferred into the flexray memory during the table write windows shown in [Figure 22-145](#). During the table write, the application can not lock the table that is currently written. If the application locks the table outside of the table write window, the lock is granted immediately.

22.6.12.5.1 Sync Frame Table Locking and Unlocking

The application locks the even/odd sync frame table by writing 1 to the lock trigger bit ELKT/OLKT in the [Sync Frame Table Configuration, Control, Status Register \(SFTCCSR\)](#). If the affected table is not currently written to the flexray memory, the lock is granted immediately, and the lock status bit ELKS/OLKS is set. If the affected table is currently written to the flexray memory, the lock is not granted. In this case, the application must issue the lock request again until the lock is granted.

The application unlocks the even/odd sync frame table by writing 1 to the lock trigger bit ELKT/OLKT. The lock status bit ELKS/OLKS is cleared immediately.

22.6.13 MTS Generation

The controller provides a flexible means to request the transmission of the Media Access Test Symbol MTS in the symbol window on channel A or channel B.

The application can configure the set of communication cycles in which the MTS will be transmitted over the FlexRay bus by programming the CYCCNTMSK and CYCCNTVAL fields in the [MTS A Configuration Register \(MTSACFR\)](#) and [MTS B Configuration Register \(MTSBCFR\)](#).

The application enables or disables the generation of the MTS on either channel by setting or clearing the MTE control bit in the [MTS A Configuration Register \(MTSACFR\)](#) or [MTS B Configuration Register \(MTSBCFR\)](#). If an MTS is to be transmitted in a certain communication cycle, the application must set the MTE control bit during the static segment of the preceding communication cycle.

The MTS is transmitted over channel A in the communication cycle with number CYCCNT, if [Equation 22-20](#), [Equation 22-21](#), and [Equation 22-21](#) are fulfilled.

$$PSR0[PROTSTATE] = POC:normal\ active \tag{Eqn. 22-19}$$

$$MTSACRF[MTE] = 1 \tag{Eqn. 22-20}$$

$$CYCCNT \& MTSACFR[CYCCNTMSK] = MTSACFR[CYCCNTVAL] \& MTSACFR[CYCCNTMSK] \tag{Eqn. 22-21}$$

The MTS is transmitted over channel B in the communication cycle with number CYCCNT, if Equation 22-19, Equation 22-22, and Equation 22-23 are fulfilled.

$$MTSBCRF[MTE] = 1 \tag{Eqn. 22-22}$$

$$CYCCNT \& MTSBCFR[CYCCNTMSK] = MTSBCFR[CYCCNTVAL] \& MTSBCFR[CYCCNTMSK] \tag{Eqn. 22-23}$$

22.6.14 Key Slot Transmission

22.6.14.1 Key Slot Assignment

A key slot is assigned to the controller if the key_slot_id field in the Protocol Configuration Register 18 (PCR18) is configured with a value greater than 0 and less or equal to number_of_static_slots in Protocol Configuration Register 2 (PCR2), otherwise no key slot is assigned.

22.6.14.2 Key Slot Transmission in POC:startup

If a key slot is assigned and the controller is in the POC:startup state, startup null frames will be transmitted as specified by FlexRay Communications System Protocol Specification, Version 2.1 Rev A.

22.6.14.3 Key Slot Transmission in POC:normal active

If a key slot is assigned and the controller is in POC:normal active, a frame of the type as shown in Table 22-115 is transmitted. If a transmit message buffer is configured for the key slot and a valid message is available, a message frame is transmitted (see Section 22.6.6.2.5, Message Transmission). If no transmit message buffer is configured for the key slot or no valid message is available, a null frame is transmitted (see Section 22.6.6.2.6, Null Frame Transmission).

Table 22-115. Key Slot Frame Type

| PCR11[key_slot_used_for_sync] | PCR11[key_slot_used_for_startup] | key slot frame type |
|-------------------------------|----------------------------------|---------------------------|
| 0 | 0 | normal frame |
| 0 | 1 | normal frame ¹ |
| 1 | 0 | sync frame |
| 1 | 1 | startup frame |

¹ The frame transmitted has an semantically incorrect header and will be detected as an invalid frame at the receiver.

22.6.15 Sync Frame Filtering

Each received synchronization frame must pass the Sync Frame Acceptance Filter and the Sync Frame Rejection Filter before it is considered for clock synchronization. If the synchronization frame filtering is

globally disabled, i.e. the SFFE control bit in the [Module Configuration Register \(MCR\)](#) is cleared, all received synchronization frames are considered for clock synchronization. If a received synchronization frame did not pass at least one of the two filters, this frame is processed as a normal frame and is not considered for clock synchronization.

22.6.15.1 Sync Frame Acceptance Filtering

The synchronization frame acceptance filter is implemented as a value-mask filter. The value is configured in the [Sync Frame ID Acceptance Filter Value Register \(SFIDAFVR\)](#) and the mask is configured in the [Sync Frame ID Acceptance Filter Mask Register \(SFIDAFMR\)](#). A received synchronization frame with the frame ID FID passes the sync frame acceptance filter, if [Equation 22-24](#) or [Equation 22-25](#) evaluates to true.

$$\text{MCR}[\text{SFFE}] = 0 \quad \text{Eqn. 22-24}$$

$$\text{ID} \ \& \ \text{SFIDAFMR}[\text{FMSK}] = \text{SFIDAFVR}[\text{FVAL}] \ \& \ \text{SFIDAFMR}[\text{FMSK}] \quad \text{Eqn. 22-25}$$

NOTE

Sync frames are transmitted in the static segment only. Thus $\text{FID} \leq 1023$.

22.6.15.2 Sync Frame Rejection Filtering

The synchronization frame rejection filter is a comparator. The compare value is defined by the [Sync Frame ID Rejection Filter Register \(SFIDRFR\)](#). A received synchronization frame with the frame ID FID passes the sync frame rejection filter if [Equation 22-26](#) or [Equation 22-27](#) evaluates to true.

$$\text{MCR}[\text{SFFE}] = 0 \quad \text{Eqn. 22-26}$$

$$\text{FID} \neq \text{SFIDRFR}[\text{SYNFRID}] \quad \text{Eqn. 22-27}$$

NOTE

Sync frames are transmitted in the static segment only. Thus $\text{FID} \leq 1023$.

22.6.16 Strobe Signal Support

The controller provides a number of strobe signals for observing internal protocol timing related signals in the protocol engine. The signals are listed and described in [Table 22-12](#).

22.6.16.1 Strobe Signal Assignment

Each of the strobe signals listed in [Table 22-12](#) can be assigned to one of the four strobe ports using the [Strobe Signal Control Register \(STBSCR\)](#). To assign multiple strobe signals, the application must write multiple times to the [Strobe Signal Control Register \(STBSCR\)](#) with appropriate settings.

To read out the current settings for a strobe signal with number N, the application must execute the following sequence.

1. Write to STBSCR with $\text{WMD} = 1$ and $\text{SEL} = \text{N}$. (updates SEL field only)

2. Read STBCSR.

The SEL field provides N and the ENB and STBPSEL fields provides the settings for signal N.

22.6.16.2 Strobe Signal Timing

This section provides detailed timing information of the strobe signals with respect to the protocol engine clock.

The strobe signals display internal PE signals. Due to the internal architecture of the PE, some signals are generated several PE clock cycles before the actual action is performed on the FlexRay Bus. These signals are listed in Table 22-12 with a negative clock offset. An example waveform is given in Figure 22-146.

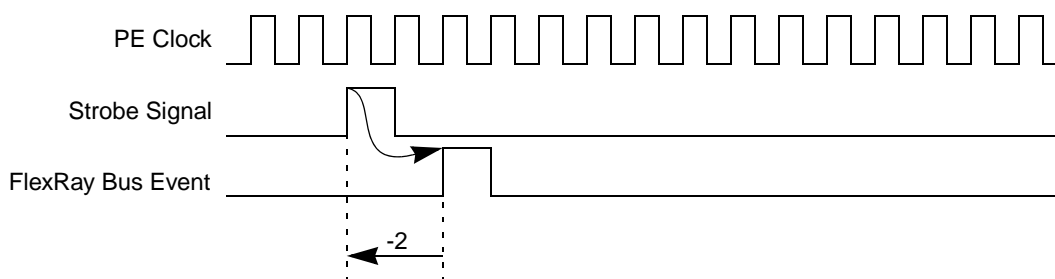

Figure 22-146. Strobe Signal Timing (type = pulse, clk_offset = -2)

Other signals refer to events that occurred on the FlexRay Bus some cycles before the strobe signal is changed. These signals are listed in Table 22-12 with a positive clock offset. An example waveform is given in Figure 22-147.

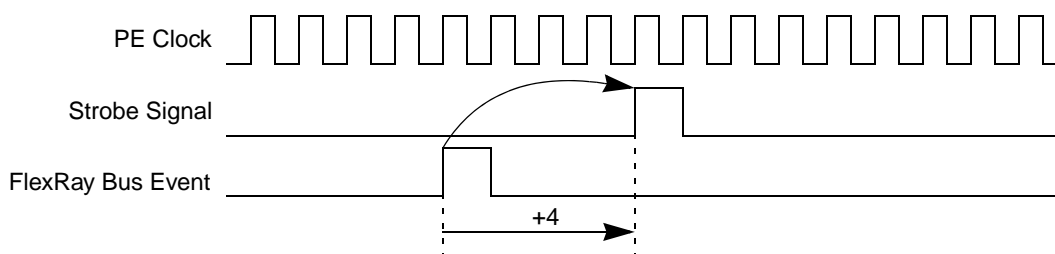

Figure 22-147. Strobe Signal Timing (type = pulse, clk_offset = +4)

22.6.17 Timer Support

The controller provides two timers, which run on the FlexRay time base. Each timer generates a maskable interrupt when it reaches a configured point in time. Timer T1 is an absolute timer. Timer T2 can be configured to be an absolute or a relative timer. Both timers can be configured to be repetitive. In the non-repetitive mode, timer stops if it expires. In repetitive mode, timer is restarted when it expires.

Both timers are active only when the protocol is in *POC:normal active* or *POC:normal passive* state. If the protocol is not in one of these modes, the timers are stopped. The application must restart the timers when the protocol has reached the *POC:normal active* or *POC:normal passive* state.

22.6.17.1 Absolute Timer T1

The absolute timer T1 has the protocol cycle count and the macrotick count as the time base. The timer 1 interrupt flag TI1_IF in the [Protocol Interrupt Flag Register 0 \(PIFR0\)](#) is set at the macrotick start event, if [Equation](#) and [Equation 22-29](#) are fulfilled

Eqn. 22-28

$$\text{CYCTR}[\text{CTCCNT}] \& \text{TI1CYSR}[\text{T1_CYC_MSK}] = \text{TI1CYSR}[\text{T1_CYC_VAL}] \& \text{TI1CYSR}[\text{T1_CYC_MSK}]$$

$$\text{MTCTR}[\text{MTCT}] = \text{TI1MTOR}[\text{T1_MTOFFSET}] \quad \text{Eqn. 22-29}$$

If the timer 1 interrupt enable bit TI1_IE in the [Protocol Interrupt Enable Register 0 \(PIER0\)](#) is asserted, an interrupt request is generated.

The status bit T1ST is set when the timer is triggered, and is cleared when the timer expires and is non-repetitive. If the timer expires but is repetitive, the T1ST bit is not cleared and the timer is restarted immediately. The T1ST is cleared when the timer is stopped.

22.6.17.2 Absolute / Relative Timer T2

The timer T2 can be configured to be an absolute or relative timer by setting the T2_CFG control bit in the [Timer Configuration and Control Register \(TICCR\)](#). The status bit T2ST is set when the timer is triggered, and is cleared when the timer expires and is non-repetitive. If the timer expires but is repetitive, the T2ST bit is not cleared and the timer is restarted immediately. The T2ST is cleared when the timer is stopped.

22.6.17.2.1 Absolute Timer T2

If timer T2 is configured as an absolute timer, it has the same functionality timer T1 but the configuration from [Timer 2 Configuration Register 0 \(TI2CR0\)](#) and [Timer 2 Configuration Register 1 \(TI2CR1\)](#) is used. On expiration of timer T2, the interrupt flag TI2_IF in the [Protocol Interrupt Flag Register 0 \(PIFR0\)](#) is set. If the timer 1 interrupt enable bit TI1_IE in the [Protocol Interrupt Enable Register 0 \(PIER0\)](#) is asserted, an interrupt request is generated.

22.6.17.2.2 Relative Timer T2

If the timer T2 is configured as a relative timer, the interrupt flag TI2_IF in the [Protocol Interrupt Flag Register 0 \(PIFR0\)](#) is set, when the programmed amount of macroticks MT[31:0], defined by [Timer 2 Configuration Register 0 \(TI2CR0\)](#) and [Timer 2 Configuration Register 1 \(TI2CR1\)](#), has expired since the trigger or restart of timer 2. The relative timer is implemented as a down counter and expires when it has reached 0. At the macrotick start event, the value of MT[31:0] is checked and then decremented. Thus, if the timer is started with MT[31:0] == 0, it expires at the next macrotick start.

22.6.18 Slot Status Monitoring

The controller provides several means for slot status monitoring. All slot status monitors use the same slot status vector provided by the PE. The PE provides a slot status vector for each static slot, for each dynamic slot, for the symbol window, and for the NIT, on a per channel base. The content of the slot status vector is described in [Table 22-116](#). The PE provides the slot status vector within the first macrotick after the end of the related slot/window/NIT, as shown in [Figure 22-148](#).

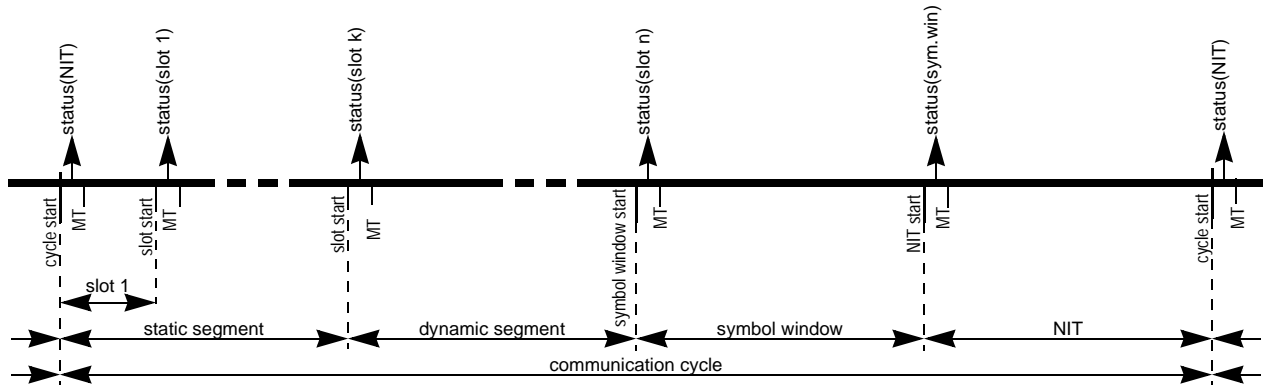

Figure 22-148. Slot Status Vector Update

NOTE

The slot status for the NIT of cycle n is provided after the start of cycle n+1.

Table 22-116. Slot Status Content

| | Status Content |
|-----------------------------|--|
| static / dynamic Slot | slot related status <i>vSS!ValidFrame</i> - valid frame received <i>vSS!SyntaxError</i> - syntax error occurred while receiving <i>vSS!ContentError</i> - content error occurred while receiving <i>vSS!BViolation</i> - boundary violation while receiving for slots in which the module transmits: <i>vSS!TxConflict</i> - reception ongoing while transmission starts for slots in which the module does not transmit: <i>vSS!TxConflict</i> - reception ongoing while transmission starts first valid - channel that has received the first valid frame received frame related status extracted from a) header of valid frame, if <i>vSS!ValidFrame</i> = 1 b) last received header, if <i>vSS!ValidFrame</i> = 0 c) set to 0, if nothing was received <i>vRF!Header!NFIndicator</i> - Null Frame Indicator (0 for null frame) <i>vRF!Header!SuFIndicator</i> - Startup Frame Indicator <i>vRF!Header!SyFIndicator</i> - Sync Frame Indicator |
| Symbol Window | window related status <i>vSS!ValidFrame</i> - always 0 <i>vSS!ContentError</i> - content error occurred while receiving <i>vSS!SyntaxError</i> - syntax error occurred while receiving <i>vSS!BViolation</i> - boundary violation while receiving <i>vSS!TxConflict</i> - reception ongoing while transmission starts received symbol related status <i>vSS!ValidMTS</i> - valid Media Test Access Symbol received received frame related status see <i>static/dynamic slot</i> |
| NIT | NIT related status <i>vSS!ValidFrame</i> - always 0 <i>vSS!ContentError</i> - content error occurred while receiving <i>vSS!SyntaxError</i> - syntax error occurred while receiving <i>vSS!BViolation</i> - boundary violation while receiving <i>vSS!TxConflict</i> - always 0 received frame related status see <i>static/dynamic slot</i> |

22.6.18.1 Channel Status Error Counter Registers

The two channel status error counter registers, [Channel A Status Error Counter Register \(CASERCR\)](#) and [Channel B Status Error Counter Register \(CBSERCR\)](#), incremented by one, if at least one of four slot status error bits, *vSS!SyntaxError*, *vSS!ContentError*, *vSS!BViolation*, or *vSS!TxConflict* is set to 1. The status vectors for all slots in the static and dynamic segment, in the symbol window, and in the NIT are taken into account. The counters wrap round after they have reached the maximum value.

22.6.18.2 Protocol Status Registers

The [Protocol Status Register 2 \(PSR2\)](#) provides slot status information about the Network Idle Time NIT and the Symbol Window. The [Protocol Status Register 3 \(PSR3\)](#) provides aggregated slot status information.

22.6.18.3 Slot Status Registers

The eight slot status registers, [Slot Status Registers \(SSR0–SSR7\)](#), can be used to observe the status of static slots, dynamic slots, the symbol window, or the NIT without individual message buffers. These registers provide all slot status related and received frame / symbol related status information, as given in [Table 22-116](#), except of the *first valid* indicator for non-transmission slots.

22.6.18.4 Slot Status Counter Registers

The controller provides four slot status error counter registers, [Slot Status Counter Registers \(SSCR0–SSCR3\)](#). Each of these slot status counter registers is updated with the value of an internal slot status counter at the start of a communication cycle. The internal slot status counter is incremented if its increment condition, defined by the [Slot Status Counter Condition Register \(SSCCR\)](#), matches the status vector provided by the PE. All static slots, the symbol window, and the NIT status are taken into account. *Dynamic slots are excluded.* The internal slot status counting and update timing is shown in [Figure 22-149](#).

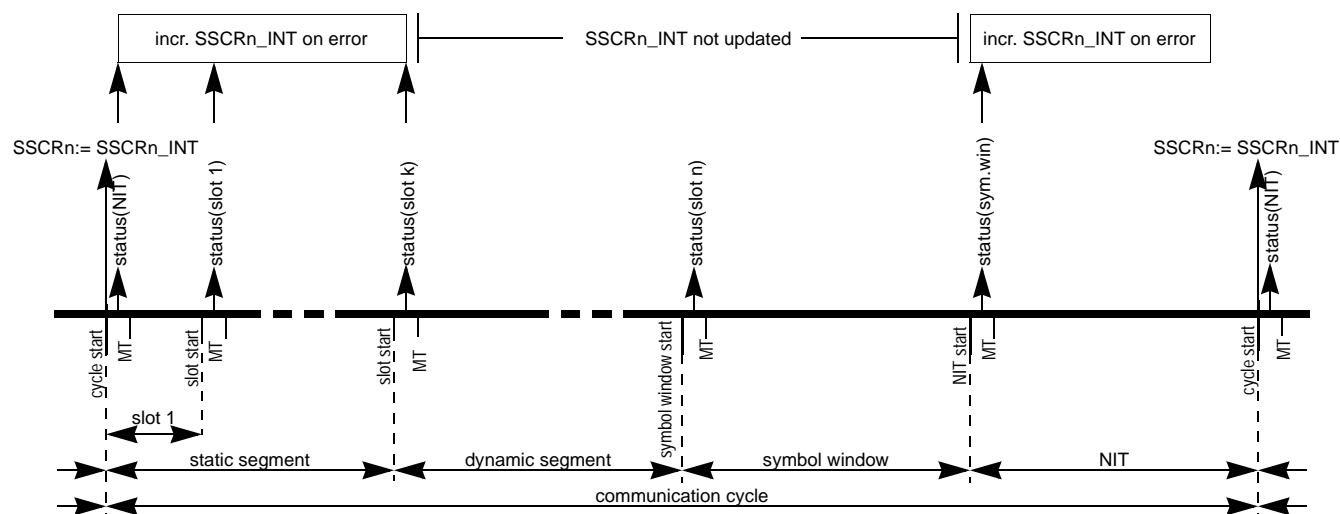

Figure 22-149. Slot Status Counting and SSCRn Update

The PE provides the status of the NIT in the first slot of the next cycle. Due to these facts, the SSCRn register reflects, in cycle n, the status of the NIT of cycle n-2, and the status of all static slots and the symbol window of cycle n-1.

The increment condition for each slot status counter consists of two parts, the frame related condition part and the slot related condition part. The internal slot status counter SSCRn_INT is incremented if at least one of the conditions is fulfilled:

1. frame related condition:

- (SSCCRn.VFR | SSSCCRn.SYF | SSSCCRn.NUF | SSSCCRn.SUF) // count on frame condition = 1;

and

- ((~SSCCRn.VFR | *vSS!ValidFrame*) & // valid frame restriction
 (~SSCCRn.SYF | *vRF!Header!SyFIndicator*) & // sync frame indicator restriction
 (~SSCCRn.NUF | *~vRF!Header!NFIndicator*) & // null frame indicator restriction
 (~SSCCRn.SUF | *vRF!Header!SuFIndicator*) // startup frame indicator restriction = 1;

NOTE

The indicator bits SYF, NUF, and SUF are valid only when a valid frame was received. Thus it is required to set the VFR always, whenever count on frame condition is used.

2. slot related condition:

- ((SSCCRn.STATUSMASK[3] & *vSS!ContentError*) | // increment on content error
 (SSCCRn.STATUSMASK[2] & *vSS!SyntaxError*) | // increment on syntax error
 (SSCCRn.STATUSMASK[1] & *vSS!BViolation*) | // increment on boundary violation
 (SSCCRn.STATUSMASK[0] & *vSS!TxConflict*)) // increment on transmission conflict = 1;

If the slot status counter is in single cycle mode, i.e. SSSCCRn.MCY = 0, the internal slot status counter SSSCCRn_INT is reset at each cycle start. If the slot status counter is in the multicycle mode, i.e. SSSCCRn.MCY = 1, the counter is not reset and incremented, until the maximum value is reached.

22.6.18.5 Message Buffer Slot Status Field

Each individual message buffer and each FIFO message buffer provides a slot status field, which provides the information shown in [Table 22-116](#) for the static/dynamic slot. The update conditions for the slot status field depend on the message buffer type. Refer to the Message Buffer Update Sections in [Section 22.6.6, Individual Message Buffer Functional Description](#).

22.6.19 System Bus Access

This section provides a description of the system bus accesses performed by the controller.

All flexray memory data located in the system memory are accessed via the system bus. There are two types of failures that can occur during the system bus access, the system bus illegal address access and the system bus access timeout.

The behavior of the controller after the occurrence of a system bus failure is defined by the SBFF bit in the [Module Configuration Register \(MCR\)](#).

22.6.19.1 System Bus Illegal Address Access

If the system bus detects an controller access to an illegal address, the controller receives a notification from the system bus about this event and sets the ILSA_EF flag in the [CHI Error Flag Register \(CHIERFR\)](#).

22.6.19.2 System Bus Access Timeout

The controller starts a timer when it has send an access request to the system bus. This timer expires after $2 * SYMATOR.TIMEOUT + 2$ system bus clock cycles. If the access is not finished within this amount of time, the SBCF_EF flag in the [CHI Error Flag Register \(CHIERFR\)](#) is set.

22.6.19.3 Continue after System Bus Failure

If the SBFF bit in the [Module Configuration Register \(MCR\)](#) is 0, the controller will continue its operation after the occurrence of the system bus access failure but will not generate any system bus accesses until the start of the next communication cycle.

If a frame is under transmission when the system bus failure occurs, a correct frame is generated with the remaining header and frame data are replaced by all zeros. Depending on the point in time this can affect the PPI bit, the Header CRC, the Payload Length in case of an dynamic slot, and the payload data. Starting from the next slot in the current cycle, no frames will be transmitted and received, except for the key slot, where a sync or startup null-frame is transmitted, if the key slot is assigned.

If a frame is received when the system bus failure occurs, the reception is aborted and the related receive message buffer is not updated.

Normal operation is resumed after the start of next communication cycle.

22.6.19.4 Freeze after System Bus Failure

If the SBFF bit in the [Module Configuration Register \(MCR\)](#) is set to 1, the controller will go into the freeze mode immediately after the occurrence of one of the system bus access failures.

22.6.20 Interrupt Support

The controller provides 172 individual interrupt sources and five combined interrupt sources.

22.6.20.1 Individual Interrupt Sources

22.6.20.1.1 Message Buffer Interrupts

The controller provides 128 message buffer interrupt sources.

Each individual message buffer provides an interrupt flag MBCCSn[MBIF] and an interrupt enable bit MBCCSn[MBIE]. The controller sets the interrupt flag when the slot status of the message buffer was updated. If the interrupt enable bit is asserted, an interrupt request is generated.

22.6.20.1.2 FIFO Interrupts

The controller provides 2 FIFO interrupt sources.

Each of the 2 FIFO provides a Receive FIFO Almost Full Interrupt Flag. The controller sets the Receive FIFO Almost Full Interrupt Flags (GIFER.FAFBIF, GIFER.FAFAIF) in the [Global Interrupt Flag and Enable Register \(GIFER\)](#) if the corresponding Receive FIFO fill level exceeds the defined watermark.

22.6.20.1.3 Wakeup Interrupt

The controller provides one interrupt source related to the wakeup.

The controller sets the Wakeup Interrupt Flag GIFER.WUPIF when it has received a wakeup symbol on the FlexRay bus. The controller generates an interrupt request if the interrupt enable bit GIFER.WUPIE is asserted.

22.6.20.1.4 Protocol Interrupts

The controller provides 25 interrupt sources for protocol related events. For details, see [Protocol Interrupt Flag Register 0 \(PIFR0\)](#) and [Protocol Interrupt Flag Register 1 \(PIFR1\)](#). Each interrupt source has its own interrupt enable bit.

22.6.20.1.5 CHI Error Interrupts

The controller provides 16 interrupt sources for CHI related error events. For details, see [CHI Error Flag Register \(CHIERFR\)](#). There is one common interrupt enable bit GIFER.CHIIE for all CHI error interrupt sources.

22.6.20.2 Combined Interrupt Sources

Each combined interrupt source generates an interrupt request only when at least one of the interrupt sources that is combined generates an interrupt request.

22.6.20.2.1 Receive Message Buffer Interrupt

The combined receive message buffer interrupt request RBIRQ is generated when at least one of the individual receive message buffers generates an interrupt request MBXIRQ[n] and the interrupt enable bit GIFER.RBIE is set.

22.6.20.2.2 Transmit Message Buffer Interrupt

The combined transmit message buffer interrupt request TBIRQ is generated when at least one of the individual transmit message buffers generates an interrupt request MBXIRQ[n] and the interrupt enable bit GIFER.TBIE is asserted.

22.6.20.2.3 Protocol Interrupt

The combined protocol interrupt request PRTIRQ is generated when at least one of the individual protocol interrupt sources generates an interrupt request and the interrupt enable bit GIFER.PRIE is set.

22.6.20.2.4 CHI Error Interrupt

The combined CHI error interrupt request CHIIRQ is generated when at least one of the individual chi error interrupt sources generates an interrupt request and the interrupt enable bit GIFER.CHIE is set.

22.6.20.2.5 Module Interrupt

The combined module interrupt request MIRQ is generated if at least one of the combined interrupt sources generates an interrupt request and the interrupt enable bit GIFER.MIE is set.

Interrupt Sources
 $n = \# \text{ Message Buffers}$
Interrupt Signals

Figure 22-150. Scheme of cascaded interrupt request

Figure 22-151.

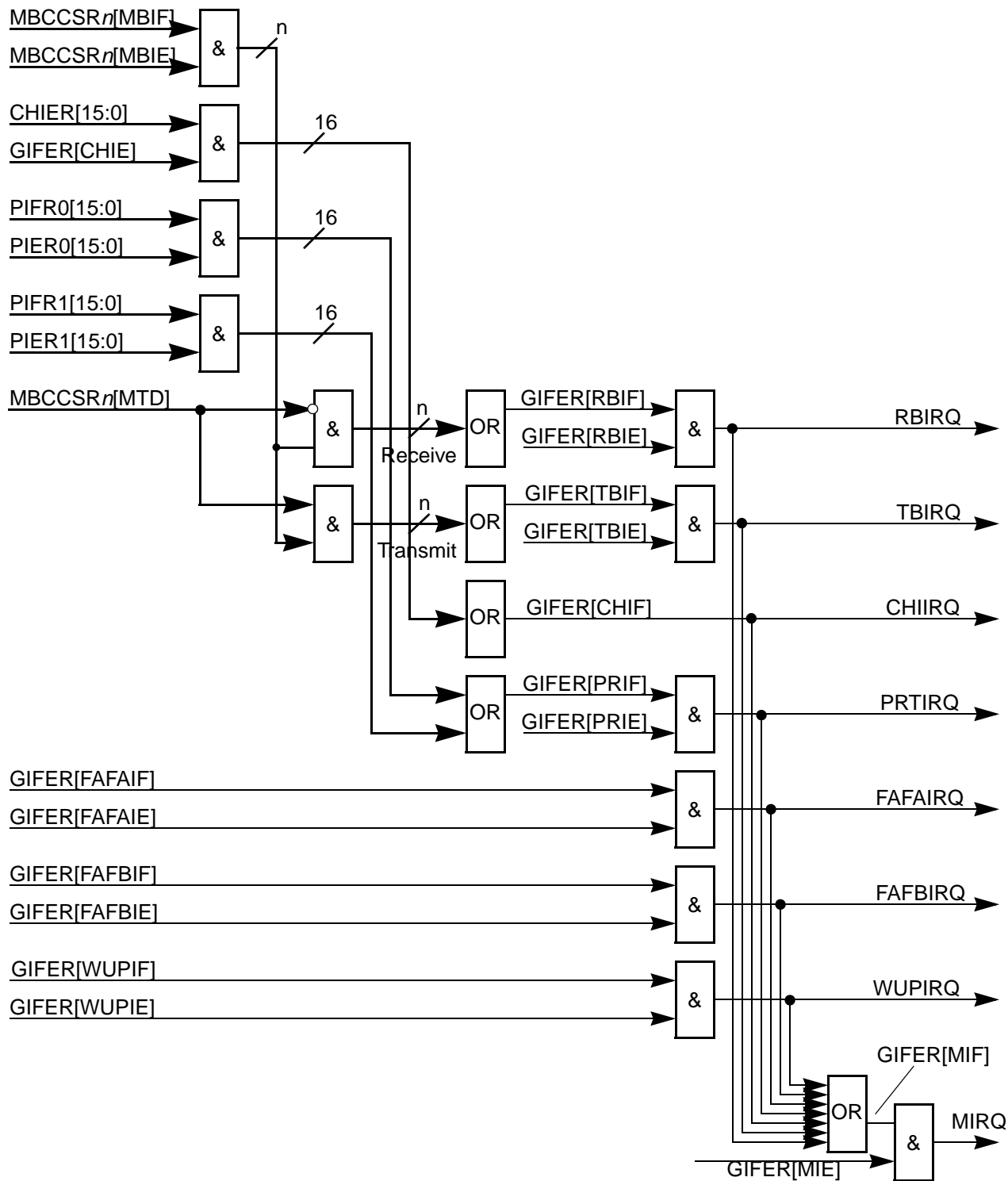
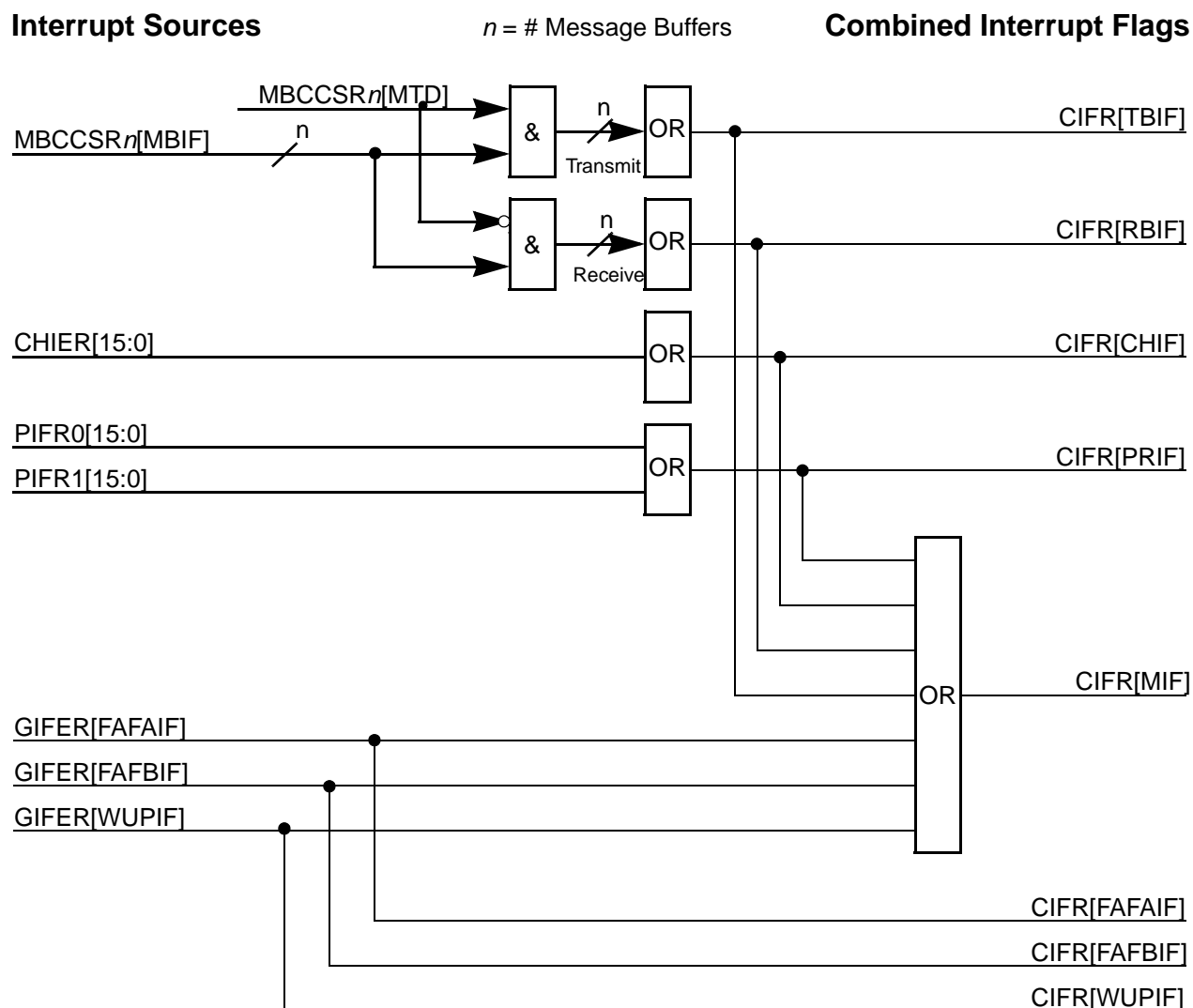

Figure 22-152. Scheme of combined interrupt flags

22.6.21 Lower Bit Rate Support

The controller supports a number of lower bit rates on the FlexRay bus channels. The lower bit rates are implemented by modifying the duration of the microtick *pdMicrotick*, the number of samples per microtick *pSamplesPerMicrotick*, the number of samples per bit *cSamplesPerBit*, and the strobe offset *cStrobeOffset*. The application configures the FlexRay channel bit rate by setting the BITRATE field in the **Module Configuration Register (MCR)**. The protocol values are set internally. The available bit rates, the related BITRATE field configuration settings and related protocol parameter values are shown in [Table 22-117](#).

Table 22-117. FlexRay Channel Bit Rate Control

| FlexRay Channel Bit Rate [Mbit/s] | MCR.BITRATE | $p_{dMicrotick}$ [ns] | $g_{dSampleClockPeriod}$ [ns] | $p_{SamplesPerMicrotick}$ | $c_{SamplesPerBit}$ | $c_{StrobeOffset}$ |
|-----------------------------------|-------------|-----------------------|-------------------------------|---------------------------|---------------------|--------------------|
| 10.0 | 000 | 25.0 | 12.5 | 2 | 8 | 5 |
| 8.0 | 011 | 25.0 | 12.5 | 2 | 10 | 6 |
| 5.0 | 001 | 25.0 | 25.0 | 1 | 8 | 5 |
| 2.5 | 010 | 50.0 | 50.0 | 1 | 8 | 5 |

NOTE

The bit rate of 8 Mbit/s is not defined by the *FlexRay Communications System Protocol Specification, Version 2.1 Rev A*.

22.7 Application Information

22.7.1 Initialization Sequence

This section describes the required steps to initialize the controller. The first subsection describes the steps required after a system reset, the second section describes the steps required after preceding shutdown of the controller.

22.7.1.1 Module Initialization

This section describes the module related initialization steps after a system reset.

1. Configure controller.
 - a) configure the control bits in the [Module Configuration Register \(MCR\)](#)
 - b) configure the system memory base address in [System Memory Base Address Register \(SYMBADR\)](#)
2. Enable the controller.
 - a) write 1 to the module enable bit MEN in the [Module Configuration Register \(MCR\)](#)

The controller now enters the Normal Mode. The application can commence with the protocol initialization described in [Section 22.7.1.2, Protocol Initialization](#).

22.7.1.2 Protocol Initialization

This section describes the protocol related initialization steps.

1. Configure the Protocol Engine.
 - a) issue CONFIG command via [Protocol Operation Control Register \(POCR\)](#)
 - b) wait for *POC:config* in [Protocol Status Register 0 \(PSR0\)](#)
 - c) configure the PCR0,..., PCR30 registers to set all protocol parameters
2. Configure the Message Buffers and FIFOs.
 - a) set the number of message buffers used and the message buffer segmentation in the [Message Buffer Segment Size and Utilization Register \(MBSSUTR\)](#)
 - b) define the message buffer data size in the [Message Buffer Data Size Register \(MBDSR\)](#)
 - c) configure each message buffer by setting the configuration values in the [Message Buffer Configuration, Control, Status Registers \(MBCCSRn\)](#), [Message Buffer Cycle Counter Filter Registers \(MBCCFRn\)](#), [Message Buffer Frame ID Registers \(MBFIDRn\)](#), [Message Buffer Index Registers \(MBIDXRn\)](#)
 - d) configure the FIFOs
 - e) issue CONFIG_COMPLETE command via [Protocol Operation Control Register \(POCR\)](#)
 - f) wait for *POC:ready* in [Protocol Status Register 0 \(PSR0\)](#)

After this sequence, the controller is configured as a FlexRay node and is ready to integrate into the FlexRay cluster.

22.7.2 Shut Down Sequence

This section describes a secure shut down sequence to stop the controller gracefully. The main targets of this sequence are

- finish all ongoing reception and transmission
- do not corrupt FlexRay bus and do not disturb ongoing FlexRay bus communication

For a graceful shutdown the application shall perform the following tasks:

1. Disable all enabled message buffers.
 - a) repeatedly write 1 to MBCCSRn[EDT] until MBCCSRn[EDS] == 0.
2. Stop Protocol Engine.
 - a) issue HALT command via [Protocol Operation Control Register \(POCR\)](#)
 - b) wait for *POC:halt* in [Protocol Status Register 0 \(PSR0\)](#)

22.7.3 Number of Usable Message Buffers

This section describes the relationship between the number of message buffers that can be utilized and the required minimum CHI clock frequency. Additional constraints for the minimum CHI clock frequency are given in [Section 22.3, Controller Host Interface Clocking](#).

The controller uses a sequential search algorithm to determine the individual message buffer assigned or subscribed to the next slot. This search must be finished within one FlexRay slot. The shortest FlexRay slot is an empty dynamic slot. An empty dynamic slot is a minislot and consists of $gdMinislot$ macroticks with a nominal duration of $gdMacrotick$. The minimum duration of a corrected macrotick is $gdMacrotick_{min} = 39 \mu\mu T$. This results in a minimum slot length of

$$\Delta_{slotmin} = 39 \cdot pdMicrotick \cdot gdMinislot \quad Eqn. 22-30$$

The search engine is located in the CHI and runs on the CHI clock. It evaluates one individual message buffer per CHI clock cycle. For internal status update and double buffer commit operations, and as a result of the clock domain crossing jitter, an additional amount of 10 CHI clock cycles is required to ensure correct operation. For a given number of message buffers and for a given CHI clock frequency f_{chi} , this results in a search duration of

$$\Delta_{search} = \frac{1}{f_{chi}} \cdot (\# MessageBuffers + 10) \quad Eqn. 22-31$$

The message buffer search must be finished within one slot which requires that Equation 22-32 must be fulfilled

$$\Delta_{search} \leq \Delta_{slotmin} \quad Eqn. 22-32$$

This results in the formula given in Equation 22-33 which determines the required minimum CHI frequency for a given number of message buffers that are utilized.

$$f_{chi} \geq \frac{\# MessageBuffers + 10}{39 \cdot pdMicrotick \cdot gdMinislot} \quad Eqn. 22-33$$

The minimum CHI frequency for a selected set of relevant protocol parameters is given in Table 22-118.

Table 22-118. Minimum f_{chi} [MHz] examples (128 message buffers)

| $pdMicrotick$ [ns] | $gdMinislot$ | | | | | |
|-----------------------|--------------|-------|-------|-------|-------|-------|
| | 2 | 3 | 4 | 5 | 6 | 7 |
| 25.0 | 70.77 | 47.18 | 35.39 | 28.31 | 23.59 | 20.22 |
| 50.0 | 35.39 | 23.59 | 17.70 | 14.16 | 11.80 | 10.11 |

22.7.4 Protocol Control Command Execution

This section considers the issues of the protocol control command execution.

The application issues any of the protocol control commands listed in the POCCMD field of Table 22-15 by writing the command to the POCCMD field of the Protocol Operation Control Register (POCR). As a result the controller sets the BSY bit while the command is transferred to the PE. When the PE has accepted the command, the BSY flag is cleared. All commands are accepted by the PE.

The PE maintains a protocol command vector. For each command that was accepted by the PE, the PE sets the corresponding command bit in the protocol command vector. If a command is issued while the corresponding command bit is set, the command is not queued and is lost.

If the command execution block of the PE is idle, it selects the next accepted protocol command with the highest priority from the current protocol command vector according to the protocol control command priorities given in [Table 22-119](#). If the current protocol state does not allow the execution of this protocol command (see POC state changes in *FlexRay Communications System Protocol Specification, Version 2.1 Rev A*) the controller asserts the illegal protocol command interrupt flag IPC_IF in the [Protocol Interrupt Flag Register 1 \(PIFR1\)](#). The protocol command is not executed in this case.

Some protocol commands may be interrupted by other commands or the detection of a fatal protocol error as indicated by [Table 22-119](#). If the application issues the FREEZE or READY command, or if the PE detects a fatal protocol error, some commands already stored in the command vector will be removed from this vector.

Table 22-119. Protocol Control Command Priorities

| Protocol Command | Priority | Interrupted By | Cleared and Terminated By |
|------------------|-------------|---|---|
| FREEZE | (highest) 1 | none | |
| READY | 2 | | |
| CONFIG_COMPLETE | 3 | | |
| ALL_SLOTS | 4 | FREEZE, READY, CONFIG_COMPLETE, fatal protocol error | FREEZE, READY, CONFIG_COMPLETE, fatal protocol error |
| ALLOW_COLDSTART | 5 | | |
| RUN | 6 | | FREEZE, fatal protocol error |
| WAKEUP | 7 | | FREEZE, fatal protocol error |
| DEFAULT_CONFIG | 8 | | FREEZE, fatal protocol error |
| CONFIG | 9 | | |
| HALT | (lowest) 10 | | FREEZE, READY, CONFIG_COMPLETE, fatal protocol error |

22.7.5 Message Buffer Search on Simple Message Buffer Configuration

This sections describes the message buffer search behavior for a simplified message buffer configuration. The FIFO behavior is not considered in this section.

22.7.5.1 Simple Message Buffer Configuration

A simple message buffer configuration is a configuration that has at most one transmit message buffer and at most one receive message buffer assigned to a slot *S*. The simple configuration used in this section utilizes two message buffers, one single buffered transmit message buffer and one receive message buffer.

The transmit message buffer has the message buffer number *t* and has following configuration

Table 22-120. Transmit Buffer Configuration

| Register | Field | Value | Description |
|------------|--------|--------|---|
| MBCCSR t | MCM | - | used only for double buffers |
| | MBT | 0 | single transmit buffer |
| | MTD | 1 | transmit buffer |
| MBCCFR t | MTM | 0 | event transition mode |
| | CHA | 1 | assigned to channel A |
| | CHB | 0 | not assigned to channel B |
| | CCFE | 1 | cycle counter filter enabled |
| | CCFMSK | 000011 | cycle set = $\{4n\} = \{0,4,8,12,\dots\}$ |
| | CCFVAL | 000000 | |
| MBFIDR t | FID | S | assigned to slot S |

The availability of data in the transmit buffer is indicated by the commit bit MBCCSR t [CMT] and the lock bit MBCCSR t [LCKS].

The receive message buffer has the message buffer number r and has following configuration

Table 22-121. Receive Buffer Configuration

| Register | Field | Value | Description |
|------------|--------|--------|--|
| MBCCSR r | MCM | - | n/a |
| | MBT | - | n/a |
| | MTD | 0 | receive buffer |
| MBCCFR r | MTM | - | n/a |
| | CHA | 1 | assigned to channel A |
| | CHB | 0 | not assigned to channel B |
| | CCFE | 1 | cycle counter filter enabled |
| | CCFMSK | 000001 | cycle set = $\{2n\} = \{0,2,4,6,\dots\}$ |
| | CCFVAL | 000000 | |
| MBFIDR r | FID | S | subscribed slot |

Furthermore the assumption is that both message buffers are enabled (MBCCSR t [EDS] = 1 and MBCCSR r [EDS] = 1)

NOTE

The cycle set $\{4n+2\} = \{2,6,10,\dots\}$ is assigned to the receive buffer only.

The cycle set $\{4n\} = \{0,4,8,12,\dots\}$ is assigned to both buffers.

- b) for the cycles in the set $\{4n+2\}$, which is assigned to the receive buffer only, the receive buffer will be found and the node can receive data.

The receive and transmit cycles are shown in [Figure 22-153](#)

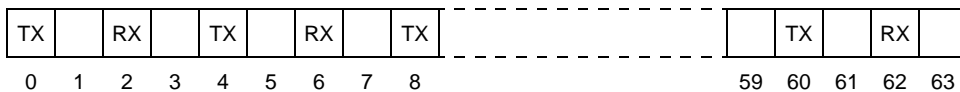

Figure 22-154. Transmit Data Not Available



Chapter 23

Enhanced Modular Input/Output Subsystem (eMIOS200)

23.1 Introduction

The eMIOS200 provides functionality to generate or measure time events. The eMIOS200 is implemented with its own configuration of timer channels to suit the target applications needs, while providing a consistent user interface with previous eMIOS implementations. The PXR40 has one eMIOS200 module that implements 24-bitcounters.

23.1.1 Block Diagram

Figure 23-1 shows the eMIOS200 block diagram.

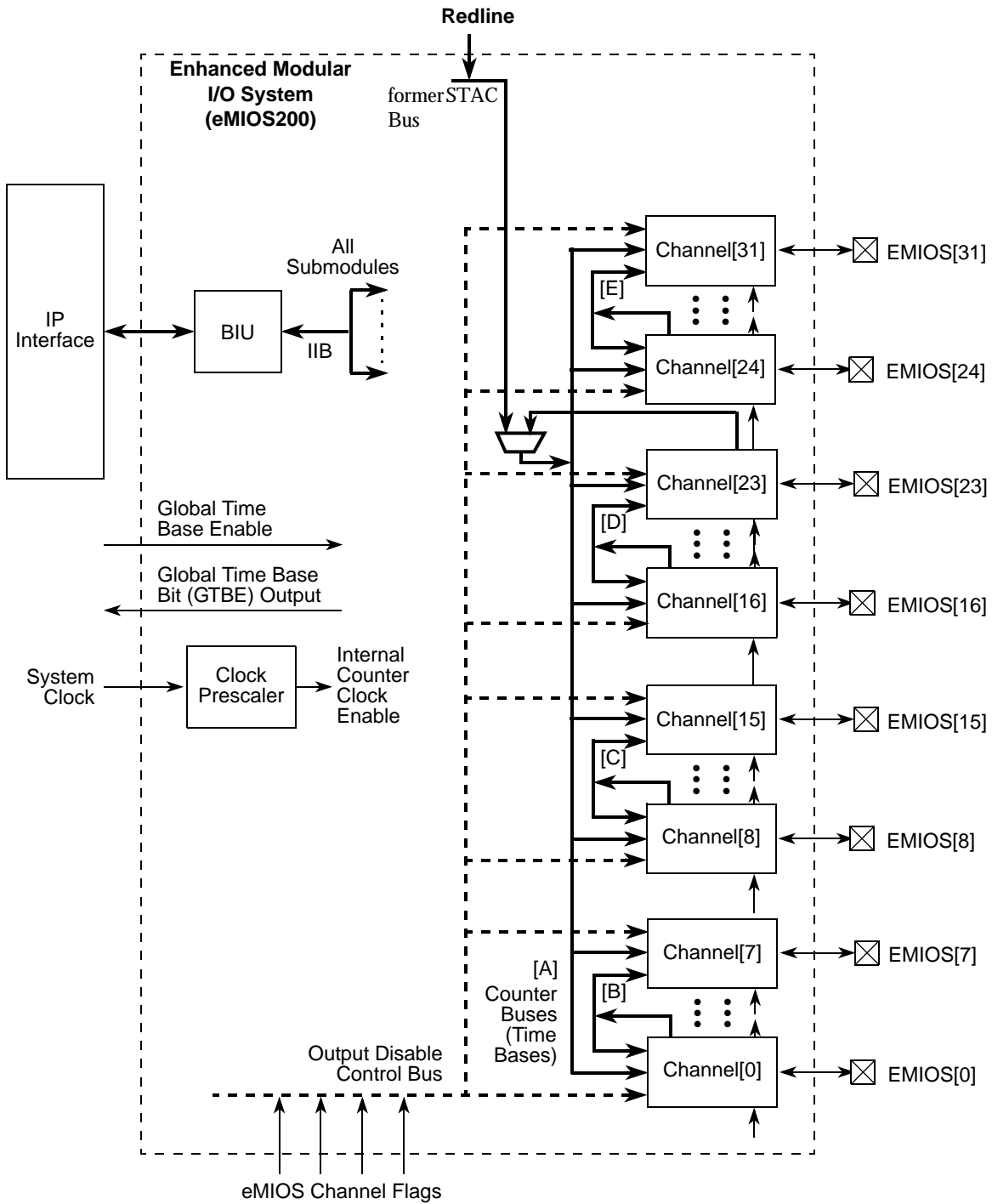

Figure 23-1. eMIOS200 Block Diagram

23.1.2 Features

- 32 unified channels (UC)
- Channel features:
 - 24-bit registers for captured/match values
 - 24-bit internal counter
 - Internal prescaler
 - Selectable time base
 - Can generate its own time base
- Five 24-bit-wide counter buses
 - Counter bus A can be driven by unified channel 23 or by the STAC bus.
 - Counter buses B, C, D, and E are driven by unified channels 0, 8, 16, and 24, respectively
 - Counter bus A can be shared among all unified channels. UCs 0 to 7, 8 to 15, 16 to 23, and 24 to 31 can share counter buses B, C, D, and E, respectively
- One global prescaler
- The output signal from the module configuration register's global time base enable bit (EMIOS_MCR[GTBE]) is wrapped back into the global timebase enable input so that the timebase of each channel can be started simultaneously.
- Shared time bases through the counter buses
- Shadow FLAG register
- State of eMIOS200 can be frozen for debug purposes
- Debug mode is supported

23.1.3 Modes of Operation

There are three main operating modes of eMIOS200: run mode, module disable mode, and debug mode. These modes are briefly described in this section.

Run mode is the normal operation mode and is described in [Section 23.4, Functional Description](#).

Module disable mode is used for MCU power management. The clock to the non-memory-mapped logic in the eMIOS200 is stopped while in module disable mode. Module disable mode is entered when $MDIS = 1$ in the EMIOS_MCR.

Debug mode is individually programmed for each channel. When entering this mode, the unified channel registers' contents are frozen, but remain available for read and write access through the IP interface.

23.1.4 eMIOS200 Channel Configurations

[Table 23-1](#) lists the eMIOS modes supported on the unified channels for this device. All included modes are on all channels.

Table 23-1. eMIOS Modes

| Description | Name | Section/Page |
|--|--------|-----------------------------------|
| General Purpose Input / Output | GPIO | 23.4.1.1.1/23-22 |
| Single Action Input Capture | SAIC | 23.4.1.1.2/23-23 |
| Single Action Output Compare | SAOC | 23.4.1.1.3/23-24 |
| Input Pulse-Width Measurement | IPWM | 23.4.1.1.4/23-26 |
| Input Period Measurement | IPM | 23.4.1.1.5/23-27 |
| Double Action Output Compare | DAOC | 23.4.1.1.6/23-29 |
| Pulse Edge Accumulation | PEA | 23.4.1.1.7/23-31 |
| Pulse Edge Counting | PEC | 23.4.1.1.8/23-33 |
| Quadrature Decode | QDEC | 23.4.1.1.9/23-35 |
| Windowed Programmable Time Accumulation | WPTA | 23.4.1.1.10/23-36 |
| Modulus Counter | MC | 23.4.1.1.11/23-37 |
| Modulus Counter Buffered (Up / Down) | MCB | 23.4.1.1.12/23-39 |
| Output Pulse Width and Frequency Modulation | OPWFM | 23.4.1.1.13/23-42 |
| Output Pulse Width and Frequency Modulation Buffered | OPWFMB | 23.4.1.1.14/23-43 |
| Center-Aligned Output PWM with Dead Time | OPWMC | 23.4.1.1.15/23-48 |
| Center-Aligned Output PWM Buffered with Dead Time | OPWMCB | 23.4.1.1.16/23-51 |
| Output Pulse Width Modulation | OPWM | 23.4.1.1.18/23-58 |
| Output Pulse Width Modulation Buffered | OPWMB | 23.4.1.1.18/23-58 |

23.2 External Signal Description

Refer to [Section 2.2, External Signal Descriptions, Pin Multiplexing, and Attributes](#), and [Section 2.3, Detailed Signal Description](#), for detailed signal descriptions.

23.2.1 eMIOS[*n*]

eMIOS[*n*] are the eMIOS channel pins. When used as an input, an eMIOS[*n*] signal is available to be read by the MCU through the UCIN bit in the EMIOS_CSR[*n*] register. When used as an output, the UCOUT bit of the EMIOS_CSR[*n*] register reflects the state of the output pin.

NOTE

All eMIOS channels support both input and output functions. When the eMIOS function is the primary function of a pin, then both the input and output functions are supported. When the eMIOS function is not the primary function of the pin, then only the output functions are supported.

23.2.2 Output Disable Input — eMIOS200 Output Disable Input Signal

Each output pin may be disabled by the assertion of a selected eMIOS channel FLAG bit from the EMIOS_GFR register described in [23.3.2.2/23-9](#). The choice of FLAG is defined by the ODIS and ODISSL bit fields of the EMIOS_CCR[*n*] described in section [23.3.2.7/23-12](#)

23.3 Memory Map and Register Description

This section provides a detailed description of all eMIOS200 registers.

23.3.1 Memory Map

The eMIOS200 memory map is shown in [Table 23-2](#). The address of each register is given as an offset to the eMIOS200 base address. Registers are listed in address order, identified by complete name and mnemonic, and lists the type of accesses allowed.

Table 23-2. eMIOS200 Memory Map

| Offset from EMIOS_BASE (0xC3FA_0000) | Register | Bits | Access ¹ | Reset Value | Section/Page |
|--------------------------------------|--|------|---------------------|-------------|--------------------------------|
| Global Registers | | | | | |
| 0x0000 | EMIOS_MCR—Module Configuration Register | 32 | R/W | 0x0000_0000 | 23.3.2.1/23-8 |
| 0x0004 | EMIOS_GFR—Global Flag Register | 32 | R | 0x0000_0000 | 23.3.2.2/23-9 |
| 0x0008 | EMIOS_OUDR—Output Update Disable Register | 32 | R/W | 0x0000_0000 | 23.3.2.3/23-10 |
| 0x000C–0x001F | Reserved | | | | |
| Unified Channel 0 Registers | | | | | |
| 0x0020 | EMIOS_CADR[0]—Channel A Data Register | 32 | R/W | 0x0000_0000 | 23.3.2.4/23-10 |
| 0x0024 | EMIOS_CBDR[0]—Channel B Data Register | 32 | R/W | 0x0000_0000 | 23.3.2.5/23-11 |
| 0x0028 | EMIOS_CCNTR[0]—Channel Counter Register | 32 | R | 0x0000_0000 | 23.3.2.6/23-12 |
| 0x002C | EMIOS_CCR[0]—Channel Control Register | 32 | R/W | 0x0000_0000 | 23.3.2.7/23-12 |
| 0x0030 | EMIOS_CSR[0]—Channel Status Register | 32 | R | 0x0000_0000 | 23.3.2.8/23-18 |
| 0x0034 | EMIOS_ALTA[0] ² —Alternate A Register | 32 | R/W | 0x0000_0000 | 23.3.2.9/23-19 |
| 0x0038–0x003F | Reserved | | | | |
| Unified Channel 1 Registers | | | | | |
| 0x0040 | EMIOS_CADR[1]—A Register | 32 | R/W | 0x0000_0000 | 23.3.2.4/23-10 |
| 0x0044 | EMIOS_CBDR[1]—B Register | 32 | R/W | 0x0000_0000 | 23.3.2.5/23-11 |
| 0x0048 | EMIOS_CCNTR[1]—Counter Register | 32 | R | 0x0000_0000 | 23.3.2.6/23-12 |
| 0x004C | EMIOS_CCR[1]—Control Register | 32 | R/W | 0x0000_0000 | 23.3.2.7/23-12 |
| 0x0050 | EMIOS_CSR[1]—Status Register | 32 | R | 0x0000_0000 | 23.3.2.8/23-18 |
| 0x0054 | EMIOS_ALTA[1] ² —Alternate A Register | 32 | R/W | 0x0000_0000 | 23.3.2.9/23-19 |
| 0x0058–0x005F | Reserved | | | | |
| Unified Channel 2 Registers | | | | | |
| 0x0060 | EMIOS_CADR[2]—A Register | 32 | R/W | 0x0000_0000 | 23.3.2.4/23-10 |
| 0x0064 | EMIOS_CBDR[2]—B Register | 32 | R/W | 0x0000_0000 | 23.3.2.5/23-11 |

Table 23-2. eMIOS200 Memory Map (continued)

| Offset from EMIOS_BASE (0xC3FA_0000) | Register | Bits | Access ¹ | Reset Value | Section/Page |
|---------------------------------------|---|------|---------------------|-------------|--------------------------------|
| 0x0068 | EMIOS_CCNTR[2]—Counter Register | 32 | R | 0x0000_0000 | 23.3.2.6/23-12 |
| 0x006C | EMIOS_CCR[2]—Control Register | 32 | R/W | 0x0000_0000 | 23.3.2.7/23-12 |
| 0x0070 | EMIOS_CSR[2]—Status Register | 32 | R | 0x0000_0000 | 23.3.2.8/23-18 |
| 0x0074 | EMIOS_ALTA[2] ² —Alternate A Register | 32 | R/W | 0x0000_0000 | 23.3.2.9/23-19 |
| 0x0078–0x007F | Reserved | | | | |
| Unified Channel 3–31 Registers | | | | | |
| 0x0080–0x041F | Same as other Channel Registers (e.g. EMIOS_CADR[2], EMIOS_CBDR[2], etc.) | 32 | — | — | — |
| 0x0420–0x3FFF | Reserved | | | | |

¹ Note that R/W registers may contain some read-only or write-only bits.

² The alternate address register provides an alternate read-only address to access A2 channel registers in pulse edge counting (PEC) and windowed programmable time accumulation (WPTA) modes. If EMIOS_CADR[*n*] register is used with EMIOS_ALTA[*n*], both A1 and A2 registers can be accessed in these modes.

Table 23-3. Unified Channel Base Offsets

| Unified Channel | Offset from EMIOS_BASE (0xC3FA_0000) | Unified Channel | Offset from EMIOS_BASE (0xC3FA_0000) |
|--------------------|--------------------------------------|--------------------|--------------------------------------|
| Unified Channel 0 | 0x0020 | Unified Channel 16 | 0x0220 |
| Unified Channel 1 | 0x0040 | Unified Channel 17 | 0x0240 |
| Unified Channel 2 | 0x0060 | Unified Channel 18 | 0x0260 |
| Unified Channel 3 | 0x0080 | Unified Channel 19 | 0x0280 |
| Unified Channel 4 | 0x00A0 | Unified Channel 20 | 0x02A0 |
| Unified Channel 5 | 0x00C0 | Unified Channel 21 | 0x02C0 |
| Unified Channel 6 | 0x00E0 | Unified Channel 22 | 0x02E0 |
| Unified Channel 7 | 0x0100 | Unified Channel 23 | 0x0300 |
| Unified Channel 8 | 0x0120 | Unified Channel 24 | 0x0320 |
| Unified Channel 9 | 0x0140 | Unified Channel 25 | 0x0340 |
| Unified Channel 10 | 0x0160 | Unified Channel 26 | 0x0360 |
| Unified Channel 11 | 0x0180 | Unified Channel 27 | 0x0380 |
| Unified Channel 12 | 0x01A0 | Unified Channel 28 | 0x03A0 |
| Unified Channel 13 | 0x01C0 | Unified Channel 29 | 0x03C0 |
| Unified Channel 14 | 0x01E0 | Unified Channel 30 | 0x03E0 |
| Unified Channel 15 | 0x0200 | Unified Channel 31 | 0x0400 |

23.3.2 Register Descriptions

This section lists the eMIOS200 registers in address order and describes the registers and their bit fields.

23.3.2.1 eMIOS200 Module Configuration Register (EMIOS_MCR)

The EMIOS_MCR contains global control bits for the eMIOS200 block.

Offset: EMIOS_BASE + 0x0000

Access: User read/write

| | | | | | | | | | | | | | | | | |
|-------|-----------|------|-----|------|-----|-------|----|----|----|----|----|----|----------|----|----|----|
| | 0 | 1 | 2 | 3 | 4 | 5 | 6 | 7 | 8 | 9 | 10 | 11 | 12 | 13 | 14 | 15 |
| R | | | | | | | 0 | 0 | 0 | 0 | 0 | 0 | SRV[0:3] | | | |
| W | | MDIS | FRZ | GTBE | ETB | GPREN | | | | | | | | | | |
| Reset | 0 | 0 | 0 | 0 | 0 | 0 | 0 | 0 | 0 | 0 | 0 | 0 | 0 | 0 | 0 | 0 |
| | 16 | 17 | 18 | 19 | 20 | 21 | 22 | 23 | 24 | 25 | 26 | 27 | 28 | 29 | 30 | 31 |
| R | GPRE[0:7] | | | | | | | | 0 | 0 | 0 | 0 | 0 | 0 | 0 | 0 |
| W | | | | | | | | | | | | | | | | |
| Reset | 0 | 0 | 0 | 0 | 0 | 0 | 0 | 0 | 0 | 0 | 0 | 0 | 0 | 0 | 0 | 0 |

Figure 23-2. eMIOS200 Module Configuration Register (EMIOS_MCR)

Table 23-4. EMIOS_MCR Field Descriptions

| Field | Description |
|-----------|--|
| 0 | Reserved. Note: Writing to this bit updates the register value, and reading it returns the last value written, but the bit has no other effect. |
| 1 MDIS | Module Disable Bit. Puts the eMIOS200 in low-power mode. The MDIS bit is used to stop the clock of the block, except the access to registers EMIOS_MCR and EMIOS_OUDR. 0 Clock is running. 1 Enter low-power mode. |
| 2 FRZ | Freeze Bit. Enables the eMIOS200 to freeze the registers of the unified channels when debug mode is requested at MCU level. Each unified channel must have FREN bit set in order to enter freeze mode. While in freeze mode, the eMIOS200 continues to operate to allow the MCU access to the unified channel registers. The unified channel remains frozen until the FRZ bit is written to 0 or the MCU exits debug mode or the unified channel FREN bit is cleared. 0 Exit freeze mode. 1 Stops unified channel operation when in debug mode and the FREN bit is set in the EMIOS_CCR[n] register. |
| 3 GTBE | Global Time Base Enable Bit. The GTBE bit is used to export a global time base enable from the module and provide a method to start time bases of several blocks simultaneously. 0 Global time base enable out signal negated. 1 Global time base enable out signal asserted. Note: The global time base enable input pin controls the internal counters. When asserted, internal counters are enabled. When negated, internal counters are disabled. |
| 4 ETB | External Time Base Bit. The ETB bit selects the time base source that drives counter bus[A]. 0 Counter bus[A] assigned to Unified Channel 23 1 STAC drives counter bus [A] If ETB is set to select STAC as the counter bus[A] source, the GTBE must be set to enable the STAC to counter bus[A]. See the STAC bus configuration register (ETPU_REDCR) section of the eTPU chapter for more information about the STAC. |

Table 23-4. EMIOS_MCR Field Descriptions (continued)

| Field | Description | | | | | | | | | | | | | | | | | | | | |
|---------------|--|------|--------------|-----------|---|-----------|---|-----------|---|-----------|---|---|---|---|---|---|---|-----------|-----|-----------|-----|
| 5 GPREN | Global Prescaler Enable Bit. The GPREN bit enables the prescaler counter. 0 Prescaler disabled and prescaler counter is cleared. 1 Prescaler enabled. | | | | | | | | | | | | | | | | | | | | |
| 6–11 | Reserved | | | | | | | | | | | | | | | | | | | | |
| 12–15 SRV | Server time slot. Selects the address of a specific STAC server to which the STAC client submodule is assigned. See Section 23.4.3, STAC Client Submodule . 0000 eTPU engine A, TCR1 0001 eTPU engine B, TCR1 0010 eTPU engine A, TCR2 0011 eTPU engine B, TCR2 0100–1111 Reserved | | | | | | | | | | | | | | | | | | | | |
| 16–23 GPRE | Global Prescaler Bits. The GPRE bits select the clock divider value for the global prescaler. <table border="1" style="margin-left: auto; margin-right: auto;"> <thead> <tr> <th>GPRE</th> <th>Divide Ratio</th> </tr> </thead> <tbody> <tr> <td>0000_0000</td> <td>1</td> </tr> <tr> <td>0000_0001</td> <td>2</td> </tr> <tr> <td>0000_0010</td> <td>3</td> </tr> <tr> <td>0000_0011</td> <td>4</td> </tr> <tr> <td>.</td> <td>.</td> </tr> <tr> <td>.</td> <td>.</td> </tr> <tr> <td>.</td> <td>.</td> </tr> <tr> <td>1111_1110</td> <td>255</td> </tr> <tr> <td>1111_1111</td> <td>256</td> </tr> </tbody> </table> | GPRE | Divide Ratio | 0000_0000 | 1 | 0000_0001 | 2 | 0000_0010 | 3 | 0000_0011 | 4 | . | . | . | . | . | . | 1111_1110 | 255 | 1111_1111 | 256 |
| GPRE | Divide Ratio | | | | | | | | | | | | | | | | | | | | |
| 0000_0000 | 1 | | | | | | | | | | | | | | | | | | | | |
| 0000_0001 | 2 | | | | | | | | | | | | | | | | | | | | |
| 0000_0010 | 3 | | | | | | | | | | | | | | | | | | | | |
| 0000_0011 | 4 | | | | | | | | | | | | | | | | | | | | |
| . | . | | | | | | | | | | | | | | | | | | | | |
| . | . | | | | | | | | | | | | | | | | | | | | |
| . | . | | | | | | | | | | | | | | | | | | | | |
| 1111_1110 | 255 | | | | | | | | | | | | | | | | | | | | |
| 1111_1111 | 256 | | | | | | | | | | | | | | | | | | | | |
| 24–31 | Reserved | | | | | | | | | | | | | | | | | | | | |

23.3.2.2 eMIOS200 Global Flag Register (EMIOS_GFR)

Offset: EMIOS_BASE + 0x0004

Access: User read-only

| | | | | | | | | | | | | | | | | |
|-------|-----|-----|-----|-----|-----|-----|-----|-----|-----|-----|-----|-----|-----|-----|-----|-----|
| | 0 | 1 | 2 | 3 | 4 | 5 | 6 | 7 | 8 | 9 | 10 | 11 | 12 | 13 | 14 | 15 |
| R | F31 | F30 | F29 | F28 | F27 | F26 | F25 | F24 | F23 | F22 | F21 | F20 | F19 | F18 | F17 | F16 |
| W | | | | | | | | | | | | | | | | |
| Reset | 0 | 0 | 0 | 0 | 0 | 0 | 0 | 0 | 0 | 0 | 0 | 0 | 0 | 0 | 0 | 0 |
| | 16 | 17 | 18 | 19 | 20 | 21 | 22 | 23 | 24 | 25 | 26 | 27 | 28 | 29 | 30 | 31 |
| R | F15 | F14 | F13 | F12 | F11 | F10 | F9 | F8 | F7 | F6 | F5 | F4 | F3 | F2 | F1 | F0 |
| W | | | | | | | | | | | | | | | | |
| Reset | 0 | 0 | 0 | 0 | 0 | 0 | 0 | 0 | 0 | 0 | 0 | 0 | 0 | 0 | 0 | 0 |

Figure 23-3. eMIOS200 Global Flag Register (EMIOS_GFR)

Table 23-5. EMIOS_GFR Field Descriptions

| Field | Description |
|------------------------------|---|
| 0–31 <i>F_n</i> | FLAG Bits. The EMIOS_GFR is a read-only register that groups the FLAG bits from all channels. These bits are mirrors of the FLAG bits of each channel register (EMIOS_CSR[<i>n</i>]). |

23.3.2.3 eMIOS200 Output Update Disable Register (EMIOS_OUDR)

Offset: EMIOS_BASE + 0x0008

Access: User read/write

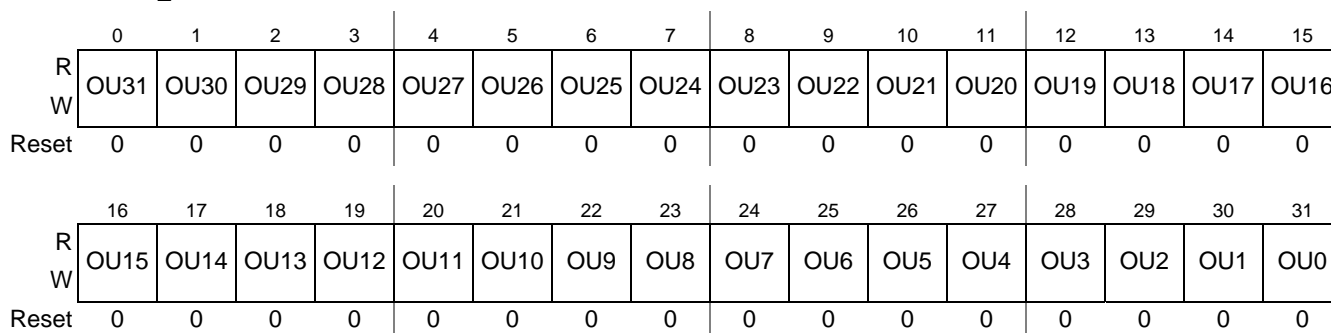

Figure 23-4. eMIOS200 Output Update Disable Register (EMIOS_OUDR)

Table 23-6. EMIOS_OUDR Field Descriptions

| Field | Description |
|-------------------------------|---|
| 0–31 <i>OU_n</i> | Channel [<i>n</i>] Output Update Disable Bits. When running MC, MCB, or an output mode, values are written to registers A2 and B2. <i>OU_n</i> bits are used to disable transfers from registers A2 to A1 and B2 to B1. Each bit controls one channel. 0 Transfer enabled. Depending on the operation mode, transfer may occur immediately or in the next period. Unless stated otherwise, transfer occurs immediately. 1 Transfers disabled. |

23.3.2.4 eMIOS200 A Register (EMIOS_CADR[*n*])

Offset: UC[*n*] base address + 0x0000

Access: User read/write

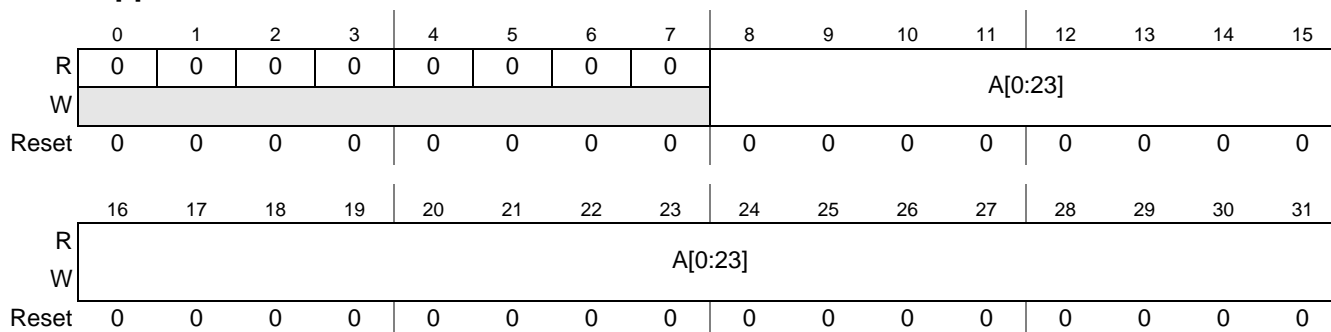

Figure 23-5. eMIOS200 A Register (EMIOS_CADR[*n*])

Depending on the mode of operation, internal registers A1 or A2, used for matches and captures, can be assigned to address EMIOS_CADR[*n*]. A1 and A2 are cleared by reset. [Table 23-7](#) summarizes the EMIOS_CADR[*n*] writing and reading accesses for all operation modes. For more information see [Section 23.4.1.1, Unified Channel Modes of Operation](#).

23.3.2.5 eMIOS200 B Register (EMIOS_CBDR[n])

Offset: UC[n] base address + 0x0004

Access: User read/write

| | | | | | | | | | | | | | | | | |
|-------|---------|----|----|----|----|----|----|----|---------|----|----|----|----|----|----|----|
| | 0 | 1 | 2 | 3 | 4 | 5 | 6 | 7 | 8 | 9 | 10 | 11 | 12 | 13 | 14 | 15 |
| R | 0 | 0 | 0 | 0 | 0 | 0 | 0 | 0 | B[0:23] | | | | | | | |
| W | | | | | | | | | | | | | | | | |
| Reset | 0 | 0 | 0 | 0 | 0 | 0 | 0 | 0 | 0 | 0 | 0 | 0 | 0 | 0 | 0 | 0 |
| | 16 | 17 | 18 | 19 | 20 | 21 | 22 | 23 | 24 | 25 | 26 | 27 | 28 | 29 | 30 | 31 |
| R | B[0:23] | | | | | | | | | | | | | | | |
| W | | | | | | | | | | | | | | | | |
| Reset | 0 | 0 | 0 | 0 | 0 | 0 | 0 | 0 | 0 | 0 | 0 | 0 | 0 | 0 | 0 | 0 |

Figure 23-6. eMIOS200 B Register (EMIOS_CBDR[n])

Depending on the mode of operation, internal registers B1 or B2 can be assigned to address EMIOS_CBDR[n]. Both B1 and B2 are cleared by reset. Table 23-7 summarizes the EMIOS_CBDR writing and reading accesses for all operation modes. For more information see section Section 23.4.1.1, Unified Channel Modes of Operation.

Depending on the channel configuration, it may have the EMIOS_CBDR register or not. This means that if at least one mode that requires the register is implemented, then the register is present. Otherwise, it is absent. PXR40 has register B (EMIOS_CBDR) in all channels.

Table 23-7. EMIOS_CADR[n], EMIOS_CBDR[n], and EMIOS_ALTA[n] Values Assignment

| Operation Mode | Register Access | | | | | |
|-------------------|-----------------|------|--------|------|-----------------|----------------|
| | Write | Read | Write | Read | Alternate Write | Alternate Read |
| GPIO | A1, A2 | A1 | B1, B2 | B1 | A2 | A2 |
| SAIC ¹ | — | A2 | B2 | B2 | — | — |
| SAOC ¹ | A2 | A1 | B2 | B2 | — | — |
| IPWM | — | A2 | — | B1 | — | — |
| IPM | — | A2 | — | B1 | — | — |
| DAOC | A2 | A1 | B2 | B1 | — | — |
| PEA | A1 | A2 | — | B1 | — | — |
| PEC ¹ | A1 | A1 | B1 | B1 | — | A2 |
| QDEC ¹ | A1 | A1 | B2 | B2 | — | — |
| WPTA | A1 | A1 | B1 | B1 | — | A2 |
| MC ¹ | A2 | A1 | B2 | B2 | — | — |
| OPWFM | A2 | A1 | B2 | B1 | — | — |
| OPWMC | A2 | A1 | B2 | B1 | — | — |
| OPWM | A2 | A1 | B2 | B1 | — | — |
| MCB ¹ | A2 | A1 | B2 | B2 | — | — |

Table 23-7. EMIOS_CADR[n], EMIOS_CBDR[n], and EMIOS_ALTA[n] Values Assignment (continued)

| Operation Mode | Register Access | | | | | |
|----------------|-----------------|------|-------|------|-----------------|----------------|
| | Write | Read | Write | Read | Alternate Write | Alternate Read |
| OPWFMB | A2 | A1 | B2 | B1 | — | — |
| OPWMCB | A2 | A1 | B2 | B1 | — | — |
| OPWMB | A2 | A1 | B2 | B1 | — | — |

¹ In these modes, the register EMIOS_CBDR[n] is not used, but B2 can be accessed.

23.3.2.6 eMIOS200 Counter Register (EMIOS_CCNTR[n])

Offset: UC[n] base address + 0x0008

Access: User read/write

| | | | | | | | | | | | | | | | | |
|-------|--------------|----|----|----|----|----|----|----|---------|----|----|----|----|----|----|----|
| | 0 | 1 | 2 | 3 | 4 | 5 | 6 | 7 | 8 | 9 | 10 | 11 | 12 | 13 | 14 | 15 |
| R | 0 | 0 | 0 | 0 | 0 | 0 | 0 | 0 | C[0:23] | | | | | | | |
| W | [Greyed out] | | | | | | | | | | | | | | | |
| Reset | 0 | 0 | 0 | 0 | 0 | 0 | 0 | 0 | 0 | 0 | 0 | 0 | 0 | 0 | 0 | 0 |
| | 16 | 17 | 18 | 19 | 20 | 21 | 22 | 23 | 24 | 25 | 26 | 27 | 28 | 29 | 30 | 31 |
| R | C[0:23] | | | | | | | | | | | | | | | |
| W | [Greyed out] | | | | | | | | | | | | | | | |
| Reset | 0 | 0 | 0 | 0 | 0 | 0 | 0 | 0 | 0 | 0 | 0 | 0 | 0 | 0 | 0 | 0 |

¹ In GPIO mode or freeze action, this register is writable.

Figure 23-7. eMIOS200 Counter Register (EMIOS_CCNTR[n])

The EMIOS_CCNTR[n] register contains the value of the internal counter for eMIOS channel *n*. When GPIO mode is selected or the channel is frozen, the EMIOS_CCNTR[n] register is read/write. For all other modes, the EMIOS_CCNTR[n] is a read-only register. When entering some operation modes, this register is automatically cleared (refer to [Section 23.4.1.1, Unified Channel Modes of Operation](#), for details).

Depending on the channel configuration it may have an internal counter or not. It means that if at least one mode that requires the counter is implemented, then the counter is present, otherwise it is absent.

23.3.2.7 eMIOS200 Control Register (EMIOS_CCR[n])

Offset: UC[n] base address + 0x000C

Access: User read/write

| | | | | | | | | | | | | | | | | |
|-------|--------------|--------------|--------------|--------------|--------------|--------------|--------------|--------------|--------------|--------------|--------------|--------------|--------------|--------------|--------------|--------------|
| | 0 | 1 | 2 | 3 | 4 | 5 | 6 | 7 | 8 | 9 | 10 | 11 | 12 | 13 | 14 | 15 |
| R | FREN | ODIS | ODISSL | | UCPRE | UC | PREN | DMA | 0 | IF | | | FCK | FEN | 0 | |
| W | [Greyed out] | [Greyed out] | [Greyed out] | [Greyed out] | [Greyed out] | [Greyed out] | [Greyed out] | [Greyed out] | [Greyed out] | [Greyed out] | [Greyed out] | [Greyed out] | [Greyed out] | [Greyed out] | [Greyed out] | [Greyed out] |
| Reset | 0 | 0 | 0 | 0 | 0 | 0 | 0 | 0 | 0 | 0 | 0 | 0 | 0 | 0 | 0 | 0 |
| | 16 | 17 | 18 | 19 | 20 | 21 | 22 | 23 | 24 | 25 | 26 | 27 | 28 | 29 | 30 | 31 |
| R | 0 | 0 | FORC | FORC | 0 | BSL | | ED | ED | MODE | | | | | | |
| W | [Greyed out] | [Greyed out] | MA | MB | [Greyed out] | [Greyed out] | [Greyed out] | SEL | POL | [Greyed out] | [Greyed out] | [Greyed out] | [Greyed out] | [Greyed out] | [Greyed out] | [Greyed out] |
| Reset | 0 | 0 | 0 | 0 | 0 | 0 | 0 | 0 | 0 | 0 | 0 | 0 | 0 | 0 | 0 | 0 |

Figure 23-8. eMIOS200 Control Register (EMIOS_CCR[n])

The control register gathers bits reflecting the status of the unified channel input/output signals and the overflow condition of the internal counter, as well as several read/write control bits.

Table 23-8. EMIOS_CCR[n] Field Descriptions

| Field | Description | | | | | | | | | | |
|---------------|--|--------|---------------------------|----|----|----|----|----|---|----|---|
| 0 FREN | Freeze Enable Bit. The FREN bit, if set and validated by FRZ bit in EMIOS_MCR register, freezes all registers' values when in debug mode, allowing the MCU to perform debug functions. 0 Normal operation. 1 Freeze unified channel registers' values. | | | | | | | | | | |
| 1 ODIS | Output Disable Bit. The ODIS bit allows disabling the output pin when running any of the output modes with the exception of GPIO mode. 0 The output pin operates normally. 1 If the selected output disable input signal is asserted, the output pin goes to EDPOL for OPWFMB and OPWMB modes and to the complement of EDPOL for other modes, but the unified channel continues to operate normally, i.e., it continues to produce FLAG and matches. When the selected output disable input signal is negated, the output pin operates normally. | | | | | | | | | | |
| 2–3 ODISSL | Output Disable Select Bits. The ODISSL bits select an eMIOS channel flag to disable an output when the flag asserts. <table border="1" data-bbox="550 795 1256 1047" style="margin-left: auto; margin-right: auto;"> <thead> <tr> <th>ODISSL</th> <th>eMIOS Channel Flag Number</th> </tr> </thead> <tbody> <tr> <td>00</td> <td>11</td> </tr> <tr> <td>01</td> <td>10</td> </tr> <tr> <td>10</td> <td>9</td> </tr> <tr> <td>11</td> <td>8</td> </tr> </tbody> </table> | ODISSL | eMIOS Channel Flag Number | 00 | 11 | 01 | 10 | 10 | 9 | 11 | 8 |
| ODISSL | eMIOS Channel Flag Number | | | | | | | | | | |
| 00 | 11 | | | | | | | | | | |
| 01 | 10 | | | | | | | | | | |
| 10 | 9 | | | | | | | | | | |
| 11 | 8 | | | | | | | | | | |
| 4–5 UCPRE | Prescaler Bits. The UCPRE bits select the clock divider value for the internal prescaler of unified channel. <table border="1" data-bbox="566 1136 1239 1388" style="margin-left: auto; margin-right: auto;"> <thead> <tr> <th>UCPRE</th> <th>Divide Ratio</th> </tr> </thead> <tbody> <tr> <td>00</td> <td>1</td> </tr> <tr> <td>01</td> <td>2</td> </tr> <tr> <td>10</td> <td>3</td> </tr> <tr> <td>11</td> <td>4</td> </tr> </tbody> </table> | UCPRE | Divide Ratio | 00 | 1 | 01 | 2 | 10 | 3 | 11 | 4 |
| UCPRE | Divide Ratio | | | | | | | | | | |
| 00 | 1 | | | | | | | | | | |
| 01 | 2 | | | | | | | | | | |
| 10 | 3 | | | | | | | | | | |
| 11 | 4 | | | | | | | | | | |
| 6 UCPREN | Prescaler Enable Bit. The UCPREN bit enables the prescaler counter. 0 Prescaler disabled. 1 Prescaler enabled and the prescaler counter is loaded with UCCPRE value. | | | | | | | | | | |
| 7 DMA | Direct Memory Access Bit. The DMA bit selects whether the FLAG generation is used as an interrupt or as a DMA request. 0 FLAG/overflow assigned to interrupt request. 1 FLAG/overflow assigned to DMA request. | | | | | | | | | | |
| 8 | Reserved | | | | | | | | | | |

Table 23-8. EMIOS_CCR[n] Field Descriptions (continued)

| Field | Description | | | | | | | | | | | | | | |
|-----------------|--|-----------------|---|------|-----------------------|------|----|------|----|------|----|------|----|------------|----------|
| 9–12 IF | <p>Input Filter Bits. The IF bits control the programmable input filter, selecting the minimum input pulse width that can pass through the filter. For output modes, these bits have no meaning.</p> <table border="1" style="margin-left: auto; margin-right: auto;"> <thead> <tr> <th>IF¹</th> <th>Minimum Input Pulse Width [FLT_CLK Periods]</th> </tr> </thead> <tbody> <tr> <td>0000</td> <td>Bypassed²</td> </tr> <tr> <td>0001</td> <td>02</td> </tr> <tr> <td>0010</td> <td>04</td> </tr> <tr> <td>0100</td> <td>08</td> </tr> <tr> <td>1000</td> <td>16</td> </tr> <tr> <td>All others</td> <td>Reserved</td> </tr> </tbody> </table> <p>¹ Filter latency is three clock edges. ² The input signal is synchronized before arriving to the digital filter.</p> | IF ¹ | Minimum Input Pulse Width [FLT_CLK Periods] | 0000 | Bypassed ² | 0001 | 02 | 0010 | 04 | 0100 | 08 | 1000 | 16 | All others | Reserved |
| IF ¹ | Minimum Input Pulse Width [FLT_CLK Periods] | | | | | | | | | | | | | | |
| 0000 | Bypassed ² | | | | | | | | | | | | | | |
| 0001 | 02 | | | | | | | | | | | | | | |
| 0010 | 04 | | | | | | | | | | | | | | |
| 0100 | 08 | | | | | | | | | | | | | | |
| 1000 | 16 | | | | | | | | | | | | | | |
| All others | Reserved | | | | | | | | | | | | | | |
| 13 FCK | <p>Filter Clock Select Bit. The FCK bit selects the clock source for the programmable input filter.</p> <p>0 Prescaled clock. 1 Main clock.</p> | | | | | | | | | | | | | | |
| 14 FEN | <p>FLAG Enable Bit. The FEN bit allows the unified channel FLAG bit to generate an interrupt signal or a DMA request signal (the type of signal to be generated is defined by the DMA bit).</p> <p>0 Disable (FLAG does not generate an interrupt or DMA request). 1 Enable (FLAG generates an interrupt or DMA request).</p> | | | | | | | | | | | | | | |
| 15–17 | Reserved | | | | | | | | | | | | | | |
| 18 FORCMA | <p>Force Match A Bit. For output modes, the FORCMA bit is equivalent to a successful comparison on comparator A (except that the FLAG bit is not set). This bit is cleared by reset and is always read as 0. This bit is valid for every output operation mode which uses comparator A, otherwise it has no effect.</p> <p>0 Has no effect. 1 Force a match at comparator A.</p> <p>For input modes, the FORCMA bit is not used and writing to it has no effect.</p> | | | | | | | | | | | | | | |
| 19 FORCMB | <p>Force Match B Bit. For output modes, the FORCMB bit is equivalent to a successful comparison on comparator B (except that the FLAG bit is not set). This bit is cleared by reset and is always read as 0. This bit is valid for every output operation mode which uses comparator B, otherwise it has no effect.</p> <p>0 Has no effect. 1 Force a match at comparator B.</p> <p>For input modes, the FORCMB bit is not used and writing to it has no effect.</p> | | | | | | | | | | | | | | |
| 20 | Reserved | | | | | | | | | | | | | | |

Table 23-8. EMIOS_CCR[n] Field Descriptions (continued)

| Field | Description | | | | | | | | | | |
|--------------|---|-----|--------------|----|------------------------------|----|---|----|----------|----|--------------------------------|
| 21–22 BSL | <p data-bbox="337 275 1469 331">Bus Select Bits. The BSL bits are used to select either one of the counter buses or the internal counter to be used by the unified channel.</p> <table border="1" data-bbox="568 348 1237 688"> <thead> <tr> <th data-bbox="573 354 769 405">BSL</th> <th data-bbox="769 354 1232 405">Selected Bus</th> </tr> </thead> <tbody> <tr> <td data-bbox="573 405 769 455">00</td> <td data-bbox="769 405 1232 455">All channels: counter bus[A]</td> </tr> <tr> <td data-bbox="573 455 769 594">01</td> <td data-bbox="769 455 1232 594"> Channels 0 to 7: counter bus[B] Channels 8 to 15: counter bus[C] Channels 16 to 23: counter bus[D] Channels 24 to 31: counter bus[E] </td> </tr> <tr> <td data-bbox="573 594 769 644">10</td> <td data-bbox="769 594 1232 644" style="background-color: #cccccc;">Reserved</td> </tr> <tr> <td data-bbox="573 644 769 688">11</td> <td data-bbox="769 644 1232 688">All channels: internal counter</td> </tr> </tbody> </table> | BSL | Selected Bus | 00 | All channels: counter bus[A] | 01 | Channels 0 to 7: counter bus[B] Channels 8 to 15: counter bus[C] Channels 16 to 23: counter bus[D] Channels 24 to 31: counter bus[E] | 10 | Reserved | 11 | All channels: internal counter |
| BSL | Selected Bus | | | | | | | | | | |
| 00 | All channels: counter bus[A] | | | | | | | | | | |
| 01 | Channels 0 to 7: counter bus[B] Channels 8 to 15: counter bus[C] Channels 16 to 23: counter bus[D] Channels 24 to 31: counter bus[E] | | | | | | | | | | |
| 10 | Reserved | | | | | | | | | | |
| 11 | All channels: internal counter | | | | | | | | | | |
| 23 EDSEL | <p data-bbox="337 709 1469 793">Edge Selection Bit. For input modes, the EDSEL bit selects if the internal counter is triggered by both edges of a pulse or by a single edge only as defined by the EDPOL bit. When not shown in the mode of operation description, this bit has no effect.</p> <p data-bbox="337 793 885 856"> 0 Single edge triggering defined by the EDPOL bit. 1 Both edges triggering. </p> <p data-bbox="337 884 1084 968"> For GPIO in mode, the EDSEL bit selects if a FLAG can be generated. 0 A FLAG is generated as defined by the EDPOL bit. 1 No FLAG is generated. </p> <p data-bbox="337 1001 1284 1085"> For SAOC mode, the EDSEL bit selects the behavior of the output flip-flop at each match. 0 The EDPOL value is transferred to the output flip-flop. 1 The output flip-flop is toggled. </p> | | | | | | | | | | |

Table 23-8. EMIOS_CCR[n] Field Descriptions (continued)

| Field | Description |
|---------------|---|
| 24 EDPOL | <p>Edge Polarity Bit. For input modes, the EDPOL bit asserts which edge triggers either the internal counter or an input capture or a FLAG. When not shown in the mode of operation description, this bit has no effect.</p> <p>0 Trigger on a falling edge. 1 Trigger on a rising edge.</p> <p>For QDEC (MODE[6] cleared), the EDPOL bit selects the count direction according to <i>direction</i> signal (UC[n] input).</p> <p>0 counts down when UC[n] is asserted 1 counts up when UC[n] is asserted</p> <p>Note: UC[n-1] EDPOL bit selects which edge clocks the internal counter of UC[n]</p> <p>0 Trigger on a falling edge 1 Trigger on a rising edge</p> <p>For QDEC (MODE[6] set), the EDPOL bit selects the count direction according to the phase difference.</p> <p>0 internal counter decrements if phase_A is ahead phase_B signal 1 internal counter increments if phase_A is ahead phase_B signal</p> <p>Note: In order to operate properly, EDPOL bit must contain the same value in UC[n] and UC[n-1]</p> <p>For output modes, the EDPOL bit is used to select the logic level on the output pin.</p> <p>0 A match on comparator A clears the output flip-flop, while a match on comparator B sets it. 1 A match on comparator A sets the output flip-flop, while a match on comparator B clears it.</p> |
| 25–31 MODE | <p>Mode Selection Bits. The MODE bits select the mode of operation of the unified channel, as shown in Table 23-9. Refer to Table 23-1 for more information on the different modes.</p> <p>Note: If a reserved value is written to MODE, the results are unpredictable.</p> |

Table 23-9. MODE Bits

| MODE | Mode | Description |
|----------|---------------|--|
| 000_0000 | GPIO (input) | General-Purpose Input/Output mode (input) |
| 000_0001 | GPIO (output) | General-Purpose Input/Output mode (output) |
| 000_0010 | SAIC | Single Action Input Capture |
| 000_0011 | SAOC | Single Action Output Compare |
| 000_0100 | IPWM | Input Pulse Width Measurement |
| 000_0101 | IPM | Input Period Measurement |
| 000_0110 | DAOC | Double Action Output compare (with FLAG set on B match) |
| 000_0111 | DAOC | Double Action Output compare (with FLAG set on both match) |
| 000_1000 | PEA | Pulse/Edge Accumulation (continuous) |
| 000_1001 | PEA | Pulse/Edge Accumulation (single-shot) |
| 000_1010 | PEC | Pulse/Edge Counting (continuous) |
| 000_1011 | PEC | Pulse/Edge Counting (single-shot) |
| 000_1100 | QDEC | Quadrature Decode (for count & direction encoders type) |

Table 23-9. MODE Bits (continued)

| MODE | Mode | Description |
|---------------------|----------|---|
| 000_1101 | QDEC | Quadrature Decode (for phase_A & phase_B encoders type) |
| 000_1110 | WPTA | Windowed Programmable Time Accumulation |
| 000_1111 | Reserved | |
| 001_0000 | MC | Modulus Counter (Up counter with clear on match start, internal clock) |
| 001_0001 | MC | Modulus Counter (Up counter with clear on match start, external clock) |
| 001_0010 | MC | Modulus Counter (Up counter with clear on match end, internal clock) |
| 001_0011 | MC | Modulus Counter (Up counter with clear on match end, external clock) |
| 001_0100 | MC | Modulus Counter (Up/Down counter with flag on A match, internal clock) |
| 001_0101 | MC | Modulus Counter (Up/Down counter with flag on A match, external clock) |
| 001_0110 | MC | Modulus Counter (Up/Down counter with flag on A match or cycle boundary, internal clock) |
| 001_0111 | MC | Modulus Counter (Up/Down counter with flag on A match or cycle boundary, external clock) |
| 001_1000 | OPWFM | Output Pulse Width and Frequency Modulation (flag on B match, immediate update) |
| 001_1001 | OPWFM | Output Pulse Width and Frequency Modulation (flag on B match, next period update) |
| 001_1010 | OPWFM | Output Pulse Width and Frequency Modulation (flag on A or B matches, immediate update) |
| 001_1011 | OPWFM | Output Pulse Width and Frequency Modulation (flag on A or B matches, next period update) |
| 001_1100 | OPWMC | Center Aligned Output Pulse Width Modulation (flag in trailing edge, trailing edge dead time) |
| 001_1101 | OPWMC | Center Aligned Output Pulse Width Modulation (flag in trailing edge, leading edge dead time) |
| 001_1110 | OPWMC | Center Aligned Output Pulse Width Modulation (flag in both edges, trailing edge dead time) |
| 001_1111 | OPWMC | Center Aligned Output Pulse Width Modulation (flag in both edges, leading edge dead time) |
| 010_0000 | OPWM | Output Pulse Width Modulation (flag on B match, immediate update) |
| 010_0001 | OPWM | Output Pulse Width Modulation (flag on B match, next period update) |
| 010_0010 | OPWM | Output Pulse Width Modulation (flag on B match, immediate update) |
| 010_0011 | OPWM | Output Pulse Width Modulation (flag on B match, next period update) |
| 010_0100 – 100_1111 | Reserved | |
| 101_0000 | MCB | Modulus Counter Buffered (Up counter with clear on match start, internal clock) |
| 101_0001 | MCB | Modulus Counter Buffered (Up counter with clear on match start, external clock) |
| 101_0010 – 101_0011 | Reserved | |
| 101_0100 | MCB | Modulus Counter Buffered (Up/Down counter with flag on A match, internal clock) |

Table 23-9. MODE Bits (continued)

| MODE | Mode | Description |
|---------------------|----------|--|
| 101_0101 | MCB | Modulus Counter Buffered (Up/Down counter with flag on A match, external clock) |
| 101_0110 | MCB | Modulus Counter Buffered (Up/Down counter with flag on A match or cycle boundary, internal clock) |
| 101_0111 | MCB | Modulus Counter Buffered (Up/Down counter with flag on A match or cycle boundary, external clock) |
| 101_1000 | OPWFMB | Output Pulse Width and Frequency Modulation Buffered, (flag on B match) |
| 101_1001 | Reserved | |
| 101_1010 | OPWFMB | Output Pulse Width and Frequency Modulation Buffered, (flag on A or B matches) |
| 101_1011 | Reserved | |
| 101_1100 | OPWMCB | Center Aligned Output Pulse Width Modulation Buffered (flag in trailing edge, trailing edge dead time) |
| 101_1101 | OPWMCB | Center Aligned Output Pulse Width Modulation Buffered (flag in trailing edge, leading edge dead time) |
| 101_1110 | OPWMCB | Center Aligned Output Pulse Width Modulation Buffered (flag in both edges, trailing edge dead time) |
| 101_1111 | OPWMCB | Center Aligned Output Pulse Width Modulation Buffered (flag in both edges, leading edge dead time) |
| 110_0000 | OPWMB | Output Pulse Width Modulation Buffered (flag on B match) |
| 110_0001 | Reserved | |
| 110_0010 | OPWMB | Output Pulse Width Modulation Buffered (flag on A or B matches) |
| 110_0011 – 111_1111 | Reserved | |

23.3.2.8 eMIOS200 Status Register (EMIOS_CSR[n])

Offset: UC[n] base address + 0x0010

Access: User read/write

| | | | | | | | | | | | | | | | | | |
|-------|------|----|----|----|----|----|----|----|----|----|----|----|----|------|-------|------|-----|
| | 0 | 1 | 2 | 3 | 4 | 5 | 6 | 7 | 8 | 9 | 10 | 11 | 12 | 13 | 14 | 15 | |
| R | OVR | 0 | 0 | 0 | 0 | 0 | 0 | 0 | 0 | 0 | 0 | 0 | 0 | 0 | 0 | 0 | |
| W | w1c | | | | | | | | | | | | | | | | |
| Reset | 0 | 0 | 0 | 0 | 0 | 0 | 0 | 0 | 0 | 0 | 0 | 0 | 0 | 0 | 0 | 0 | |
| | 16 | 17 | 18 | 19 | 20 | 21 | 22 | 23 | 24 | 25 | 26 | 27 | 28 | 29 | 30 | 31 | |
| R | OVFL | 0 | 0 | 0 | 0 | 0 | 0 | 0 | 0 | 0 | 0 | 0 | 0 | UCIN | UCOUT | FLAG | |
| W | w1c | | | | | | | | | | | | | | | | w1c |
| Reset | 0 | 0 | 0 | 0 | 0 | 0 | 0 | 0 | 0 | 0 | 0 | 0 | 0 | 0 | 0 | 0 | |

Figure 23-9. eMIOS200 Status Register (EMIOS_CSR[n])

Table 23-10. EMIOS_CSR[n] Field Descriptions

| Field | Description |
|-------------|--|
| 0 OVR | Overrun Bit. The OVR bit indicates that FLAG generation occurred when the FLAG bit was already set. This bit can be cleared by clearing the FLAG bit or by software writing a 1. 0 Overrun has not occurred. 1 Overrun has occurred. |
| 1–15 | Reserved |
| 16 OVFL | Overflow Bit. The OVFL bit indicates that an overflow has occurred in the internal counter. This bit must be cleared by software writing a 1. 0 An overflow has not occurred. 1 An overflow has occurred. |
| 17–28 | Reserved |
| 29 UCIN | Unified Channel Input Pin Bit. The UCIN bit reflects the input pin state after being filtered and synchronized. |
| 30 UCOUT | Unified Channel Output. The UCOUT bit reflects the output pin state. |
| 31 FLAG | FLAG Bit. The FLAG bit is set when an input capture or a match event in the comparators occurred. This bit must be cleared by software writing a 1. 0 FLAG cleared. 1 FLAG set event has occurred. Note: emios_flag_out reflects the FLAG bit value. When the DMA bit is set, the FLAG bit can be cleared by the DMA controller. |

23.3.2.9 eMIOS200 Alternate A Register (EMIOS_ALTA[n])

UC[n] base address + 0x0014

Access: User read/write

| | | | | | | | | | | | | | | | | |
|-------|------------|----|----|----|----|----|----|----|------------|----|----|----|----|----|----|----|
| | 0 | 1 | 2 | 3 | 4 | 5 | 6 | 7 | 8 | 9 | 10 | 11 | 12 | 13 | 14 | 15 |
| R | 0 | 0 | 0 | 0 | 0 | 0 | 0 | 0 | ALTA[0:23] | | | | | | | |
| W | | | | | | | | | | | | | | | | |
| Reset | 0 | 0 | 0 | 0 | 0 | 0 | 0 | 0 | 0 | 0 | 0 | 0 | 0 | 0 | 0 | 0 |
| | 16 | 17 | 18 | 19 | 20 | 21 | 22 | 23 | 24 | 25 | 26 | 27 | 28 | 29 | 30 | 31 |
| R | ALTA[0:23] | | | | | | | | | | | | | | | |
| W | | | | | | | | | | | | | | | | |
| Reset | 0 | 0 | 0 | 0 | 0 | 0 | 0 | 0 | 0 | 0 | 0 | 0 | 0 | 0 | 0 | 0 |

Figure 23-10. eMIOS200 Alternate A Register (EMIOS_ALTA[n])

The EMIOS_ALTA[n] register provides an alternate read-only address to access A2 channel registers in GPIO, PEC, WPTA, and OPWMT modes. If the EMIOS_CADR[n] register is used with EMIOS_ALTA[n], both A1 and A2 registers can be accessed in these modes.

23.4 Functional Description

The eMIOS200 provides independently operating unified channels (UC) that can be configured and accessed by a host MCU. The five time bases can be shared by the channels through five counter buses and each unified channel can generate its own time base.

The eMIOS200 block is reset asynchronously. All registers are cleared on reset.

23.4.1 Unified Channel (UC)

Figure • shows the unified channel block diagram. Each unified channel consists of:

- Counter bus selector, which selects the time base to be used by the channel for all timing functions
- A programmable clock prescaler
- Two double-buffered data registers, A and B, that allow up to two input capture and/or output compare events to occur before software intervention is needed
- Two comparators (equal only), A and B, which compare the selected counter bus with the value in the data registers
- Internal counter, which can be used as a local time base or to count input events
- Programmable input filter, which ensures that only valid pin transitions are received by channel
- Programmable input edge detector, which detects the rising, falling or either edges
- An output flip-flop, which holds the logic level to be applied to the output pin
- eMIOS200 status and control register

- An output disable input selector, which selects the output disable input signal to be used as output disable

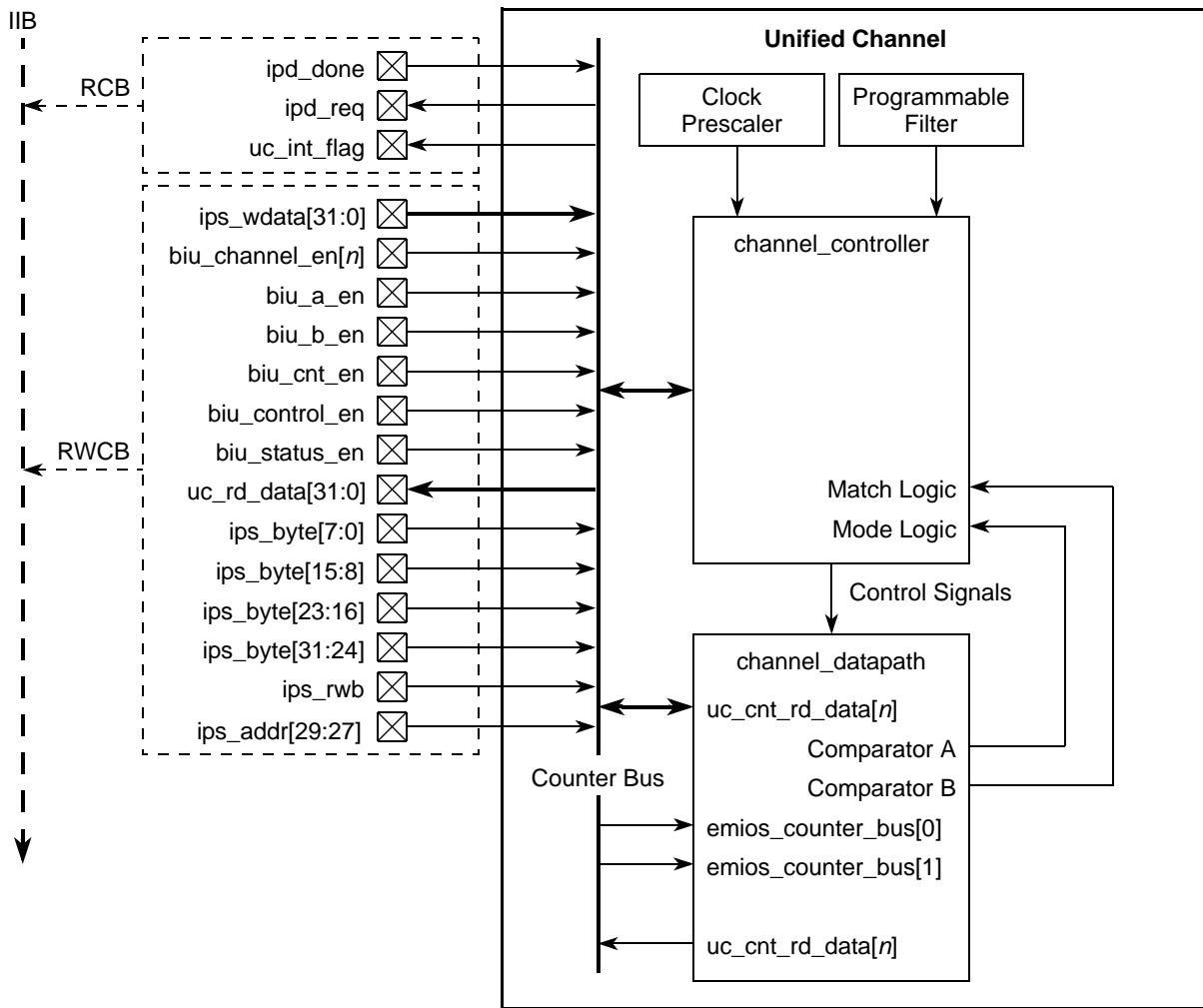

Figure 23-11. Unified Channel Block Diagram

Figure 23-12 shows the unified channel control block diagram.

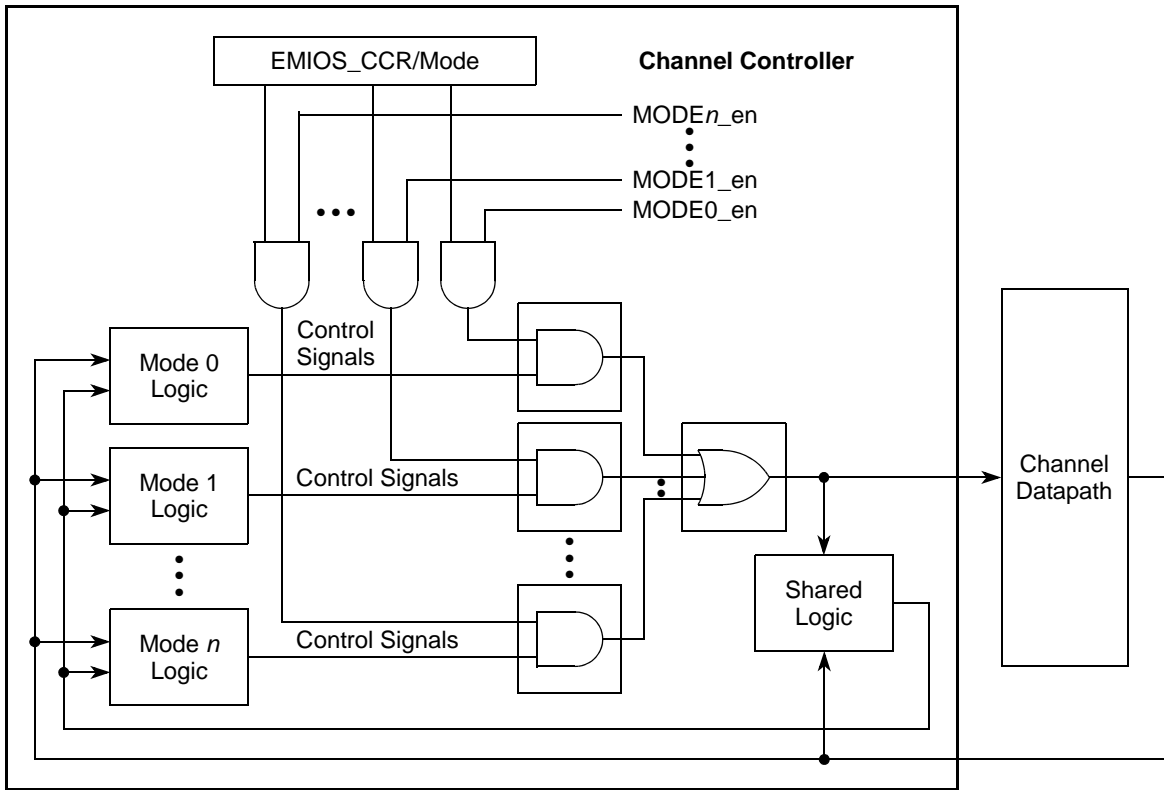

Figure 23-12. Unified Channel Control Block Diagram

23.4.1.1 Unified Channel Modes of Operation

The mode of operation of the unified channel is determined by the mode select bits MODE in the EMIOS_CCR[n] register (see Table 23-9 for details).

When entering an output mode (except for GPIO mode), the output flip-flop is set to the complement of the EDPOL bit in the EMIOS_CCR[n] register.

As the internal counter EMIOS_CCNTR[n] continues to run in all modes (except for GPIO mode), it is possible to use this as a time base if the resource is not used in the current mode.

In order to provide smooth waveform generation even if A and B registers are changed on the fly, the MCB, OPWFMB, OPWMB and OPWMCB modes are available. In these modes, the A and B registers are double-buffered. These modes are presented in separate sections since basic differences exist between these modes and the MC, OPWFM, OPWM, and OPWMC modes, respectively.

23.4.1.1.1 General-Purpose Input/Output (GPIO) Mode

In GPIO mode, all input capture and output compare functions of the unified channel are disabled, the internal counter (EMIOS_CCNTR[n] register) is cleared and disabled. All control bits remain accessible. In order to prepare the unified channel for a new operation mode, writing to registers EMIOS_CADR[n] or EMIOS_CBDR[n] stores the same value in registers A1/A2 or B1/B2, respectively.

The MODE[6] bit selects between input (MODE[6] = 0) and output (MODE[6] = 1) modes.

When changing the MODE bits, the application software must go to GPIO mode first to reset the unified channel's internal functions properly. Failure to do this could lead to invalid and unexpected output compare or input capture results or the FLAGs being set incorrectly.

In GPIO input mode (MODE = 000_0000), the FLAG generation is determined according to EDPOL and EDSEL bits and the input pin status can be determined by reading the UCIN bit.

In GPIO output mode (MODE = 000_0001), the unified channel is used as a single output port pin and the value of the EDPOL bit is permanently transferred to the output flip-flop.

23.4.1.1.2 Single Action Input Capture (SAIC) Mode

In SAIC mode (MODE = 000_0010), when a triggering event occurs on the input pin, the value on the selected time base is captured into register A2. At the same time, the FLAG bit is set to indicate that an input capture has occurred. The EMIOS_CADR[n] register returns the value of register A2. The channel is ready to capture events as soon as SAIC mode is entered coming out from GPIO mode. The events are captured as soon as they occur, thus reading register A (EMIOS_CADR) always returns the value of the latest captured event. Subsequent captures are enabled with no need of further reads from the EMIOS_CADR[n] register. The FLAG bit is set at any time a new event is captured.

The input capture is triggered by a rising, falling, or either edge on the input pin, as configured by the EDPOL and EDSEL bits in EMIOS_CCR[n] register.

Figure 23-13 and Figure 23-14 show how the unified channel can be used for input capture.

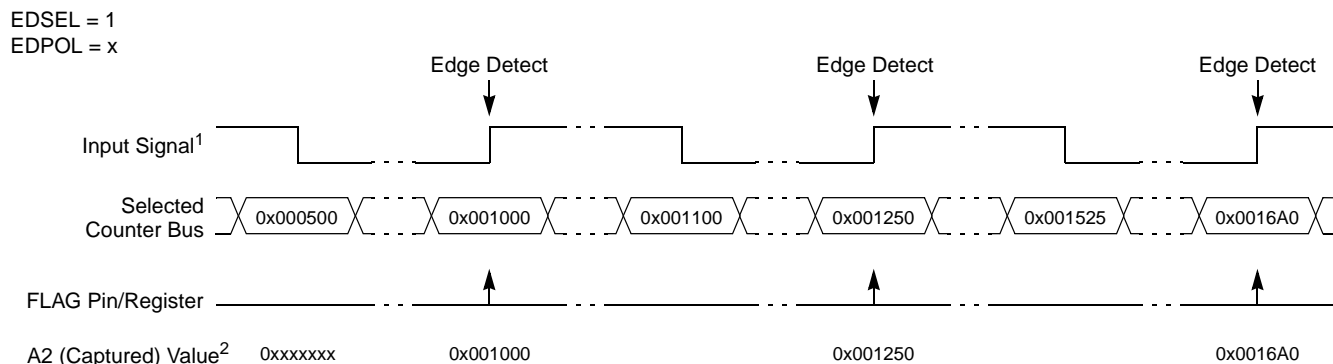

- Notes:
1. After input filter
 2. EMIOS_CADR[n] ≤ A2

Figure 23-13. SAIC with Rising Edge Triggering Example

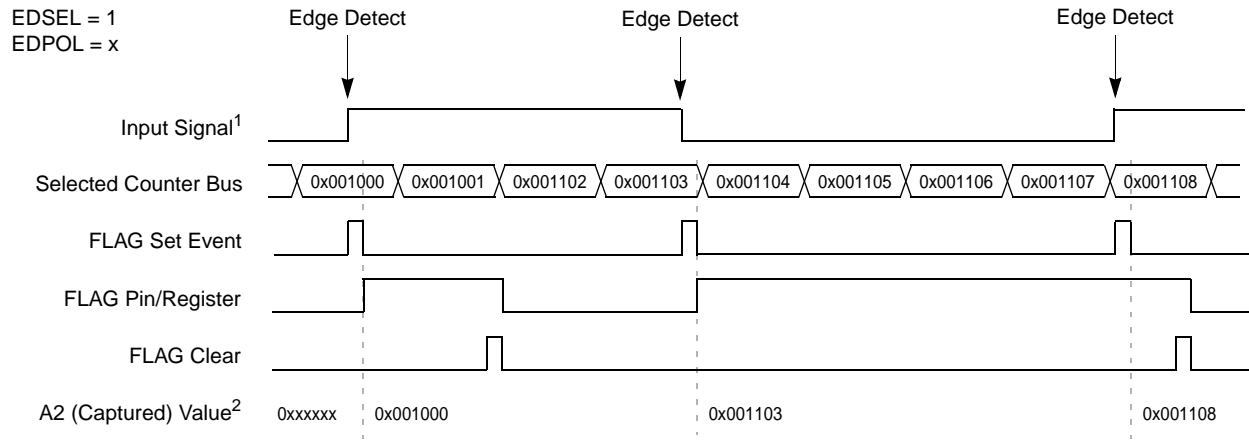

Notes: 1 After input filter
2 EMIOS_CADR[n] ≤ A2

Figure 23-14. SAIC with Both Edges Triggering Example

23.4.1.1.3 Single Action Output Compare (SAOC) Mode

In SAOC mode (MODE = 000_0011), a match value is loaded in register A2 and then transferred to register A1 to be compared with the selected time base. When a match occurs, the EDSEL bit selects whether the output flip-flop is toggled or the value in EDPOL is transferred to it. At the same time, the FLAG bit is set to indicate that the output compare match has occurred. Writing to the EMIOS_CADR[n] register stores the value in register A2 and reading to the EMIOS_CADR[n] register returns the value of register A1.

An output compare match can be simulated in software by setting the FORCMA bit in the EMIOS_CCR[n] register. In this case, the FLAG bit is not set.

When SAOC mode is entered coming out of GPIO mode, the output flip-flop is set to the complement of the EDPOL bit in the EMIOS_CCR[n] register.

The counter bus can be either internal or external and is selected through the BSL bits.

Figure 23-15 and Figure 23-16 show how the unified channel can be used to perform a single output compare with the EDPOL value being transferred to the output flip-flop and toggling the output flip-flop at each match, respectively. Note that once in SAOC mode, the matches are enabled. Thus the desired match value on register A1 must be written before the mode is entered. Register A1 can be updated at any time, thus modifying the match value, which is reflected in the output signal generated by the channel. Subsequent matches are enabled with no need of further writes to EMIOS_CADR[n]. The FLAG bit is set at the same time a match occurs (see Figure 23-17).

NOTE

In SAOC mode, the internal channel counter is free-running, and starts counting as soon as the SAOC mode is entered.

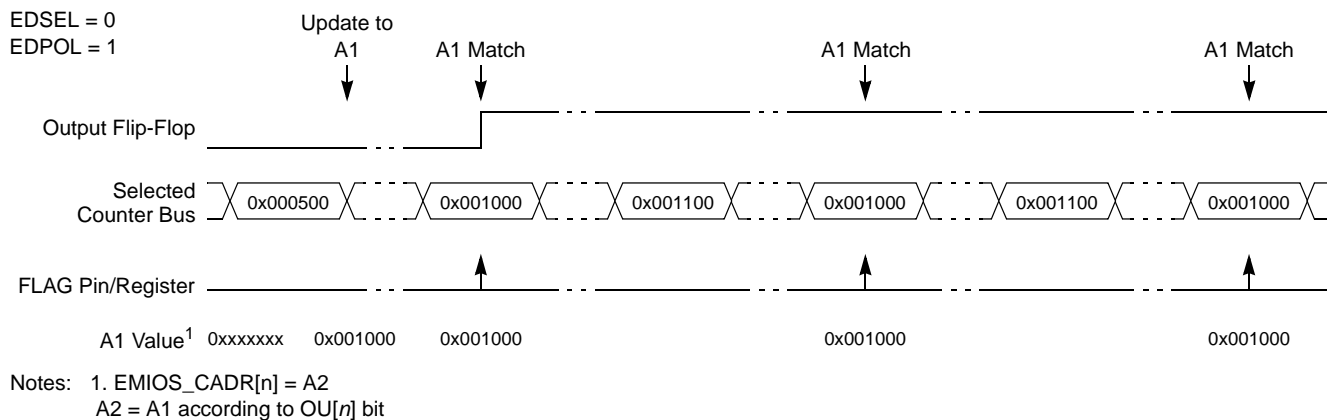
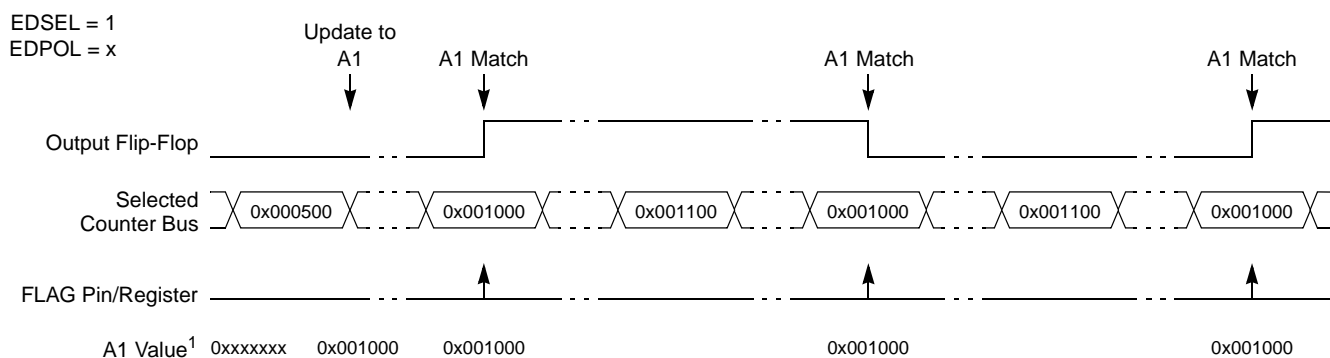
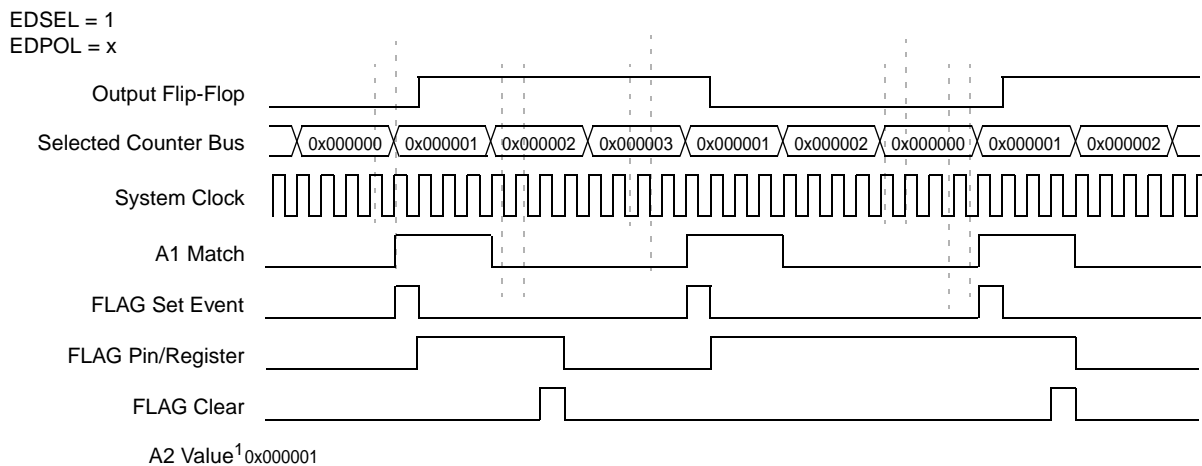

Figure 23-15. SAOC Example — EDPOL Value Being Transferred to the Output Flip-flop



Note: 1. EMIOS_CADR[n] = A2

Figure 23-16. SAOC Example — Toggling the Output Flip-Flop



Note: 1. EMIOS_CADR[n] ≤ A2

Figure 23-17. SAOC Example with Flag Behavior

23.4.1.1.4 Input Pulse-Width Measurement (IPWM) Mode

The IPWM mode (MODE = 000_0100) allows measuring the width of a positive or negative pulse by capturing the leading edge on register B1 and the trailing edge on register A2. Successive captures are done on consecutive edges of opposite polarity. The leading edge sensitivity (i.e., pulse polarity) is selected by the EDPOL bit in the EMIOS_CCR[n] register. Registers EMIOS_CADR[n] and EMIOS_CBDR[n] return the values in register A2 and B1, respectively.

The capture function of register A2 remains disabled until the first leading edge triggers the first input capture on register B2. When this leading edge is detected, the count value of the selected time base is latched into register B2; the FLAG bit is not set. When the trailing edge is detected, the count value of the selected time base is latched into register A2. At the same time, the FLAG bit is set and the content of register B2 is transferred to register B1 and to register A1.

If subsequent input capture events occur while the corresponding FLAG bit is set, registers A2, B1, and A1 are updated with the latest captured values and the FLAG remains set. Registers EMIOS_CADR[n] and EMIOS_CBDR[n] return the value in registers A2 and B1, respectively.

In order to guarantee coherent access, reading EMIOS_CADR[n] forces B1 to be updated with the content of register A1. At the same time, transfers between B2 and B1 are disabled until the next read of EMIOS_CBDR[n] register. Reading EMIOS_CBDR[n] register forces B1 be updated with A1 register content and re-enables transfers from B2 to B1, to take effect at the next trailing edge capture. Transfers from B2 to A1 are not blocked at any time.

The input pulse width is calculated by subtracting the value in B1 from A2.

Figure 23-18 shows how the unified channel can be used for input pulse-width measurement.

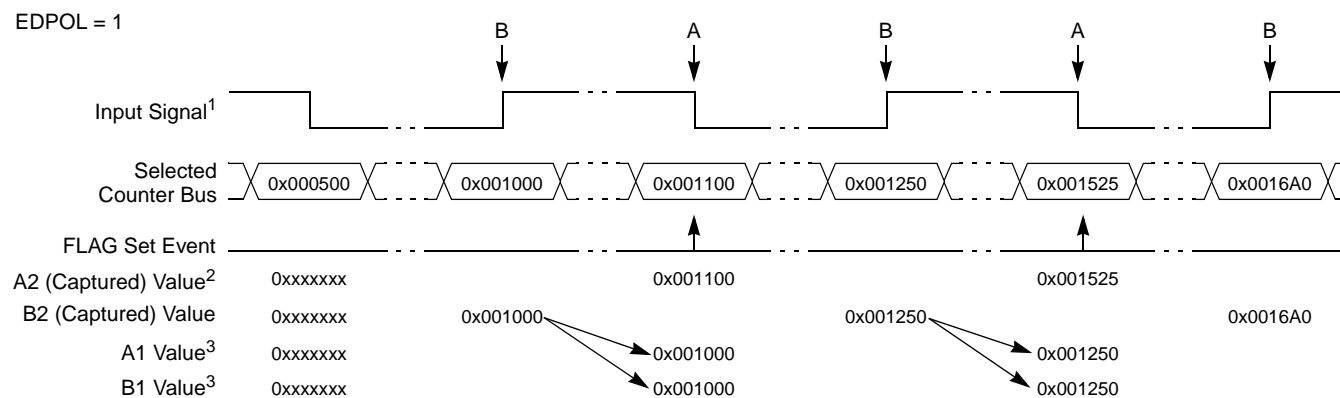

- Notes:
1. After input filter
 2. EMIOS_CADR[n] = A2
 3. EMIOS_CBDR[n] = B1

Figure 23-18. IPWM Example

Figure 23-19 shows the A1 and B1 updates when EMIOS_CADR[n] and EMIOS_CBDR[n] register reads occur. The A1 register has always coherent data related to the A2 register. When a EMIOS_CADR[n] read is performed, the B1 register is loaded with the A1 register content. This guarantees that the data in register B1 always has the coherent data related to the last EMIOS_CADR[n] read. The B1 register updates remain

locked until a `EMIOS_CBDR[n]` read occurs. If a read of `EMIOS_CADR[n]` is performed, B1 is updated with contents of A1 even if the B1 update is locked by a previous `EMIOS_CADR[n]` read operation.

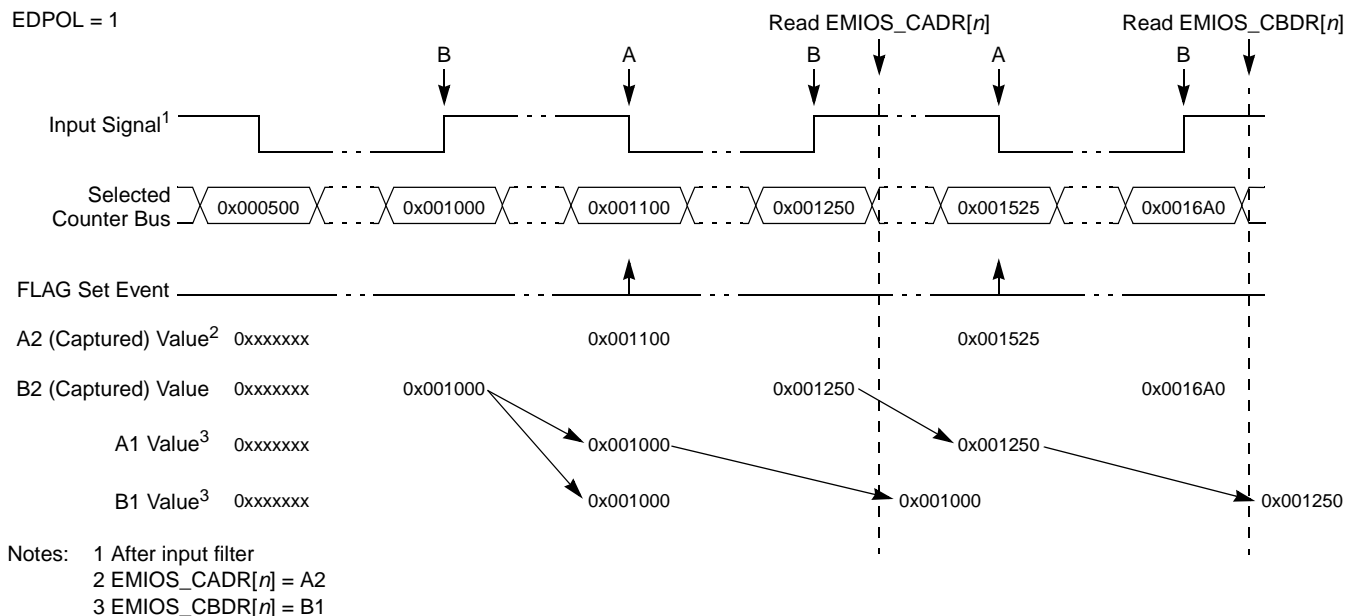

Figure 23-19. B1 and A1 Updates at `EMIOS_CADR[n]` and `EMIOS_CBDR[n]` Reads

Reading `EMIOS_CADR[n]` followed by `EMIOS_CBDR[n]` always provides coherent data. If coherent data is not required, the sequence of reads should be inverted, and `EMIOS_CBDR[n]` should be read before `EMIOS_CADR[n]`. Even in this case, register B1 updates are blocked after `EMIOS_CADR[n]` is read. Therefore, a second `EMIOS_CBDR[n]` read is required to release the B1 register updates.

23.4.1.1.5 Input Period Measurement (IPM) Mode

The IPM mode (`MODE = 000_0101`) allows the measurement of the period of an input signal by capturing two consecutive rising edges or two consecutive falling edges. Successive input captures are done on consecutive edges of the same polarity. The edge polarity is defined by the `EDPOL` bit in the `EMIOS_CCR[n]` register.

When the first edge of selected polarity is detected, the selected time base is latched into the registers A2 and B2, and the data previously held in register B2 is transferred to register B1. On this first capture the `FLAG` line is not set and the values in registers B1 are meaningless. On the second and subsequent captures, the `FLAG` line is set and data in register B2 is transferred to register B1.

When the second edge of the same polarity is detected, the counter bus value is latched into registers A2 and B2, and the data previously held in register B2 is transferred to data register B1 and to register A1. The `FLAG` bit is set to indicate that the start and end points of a complete period have been captured. This sequence of events is repeated for each subsequent capture. The `EMIOS_CADR[n]` and `EMIOS_CBDR[n]` registers return the values in the A2 and B1 registers, respectively.

To allow coherent data, reading `EMIOS_CADR[n]` forces A1 content be transferred to B1 register and disables transfers between B2 and B1. These transfers are disabled until the next read of the

EMIOS_CBDR[n] register. Reading EMIOS_CBDR[n] register forces A1 content to be transferred to B1 and re-enables transfers from B2 to B1, to take effect at the next edge capture.

The input pulse period is calculated by subtracting the value in B1 from A2.

Figure 23-20 shows how the unified channel can be used for input period measurement.

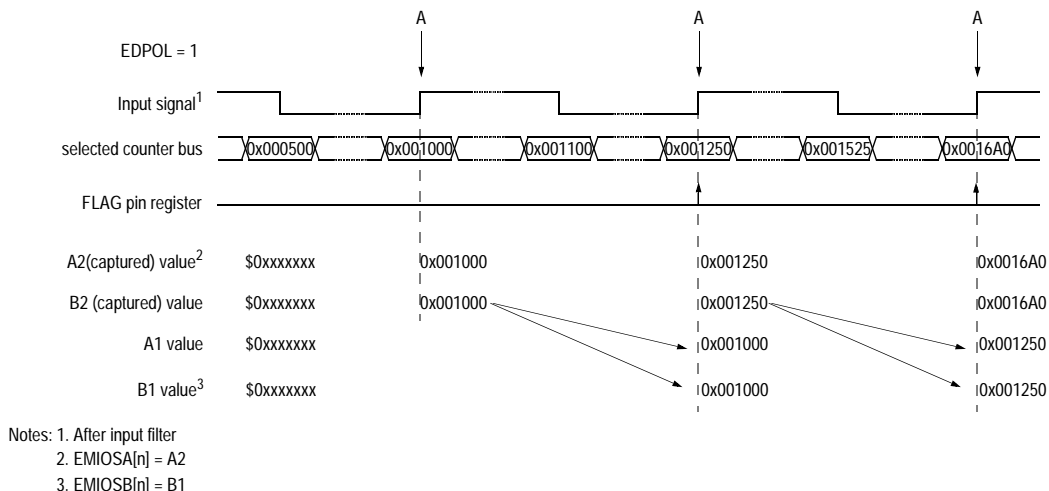

Figure 23-20. IPM Example

Figure 23-21 shows the A1 and B1 register updates when EMIOS_CADR[n] and EMIOS_CBDR[n] read operations are performed. When a EMIOS_CADR[n] read occurs, the contents of A1 are transferred to B1, thus providing coherent data in the A2 and B1 registers. Transfers from B2 to B1 are then blocked until EMIOS_CBDR[n] is read. After EMIOS_CBDR[n] is read, the contents of register A1 are transferred to register B1 and the transfers from B2 to B1 are re-enabled to occur at the transfer edges, which is the leading edge in the Figure 23-21 example.

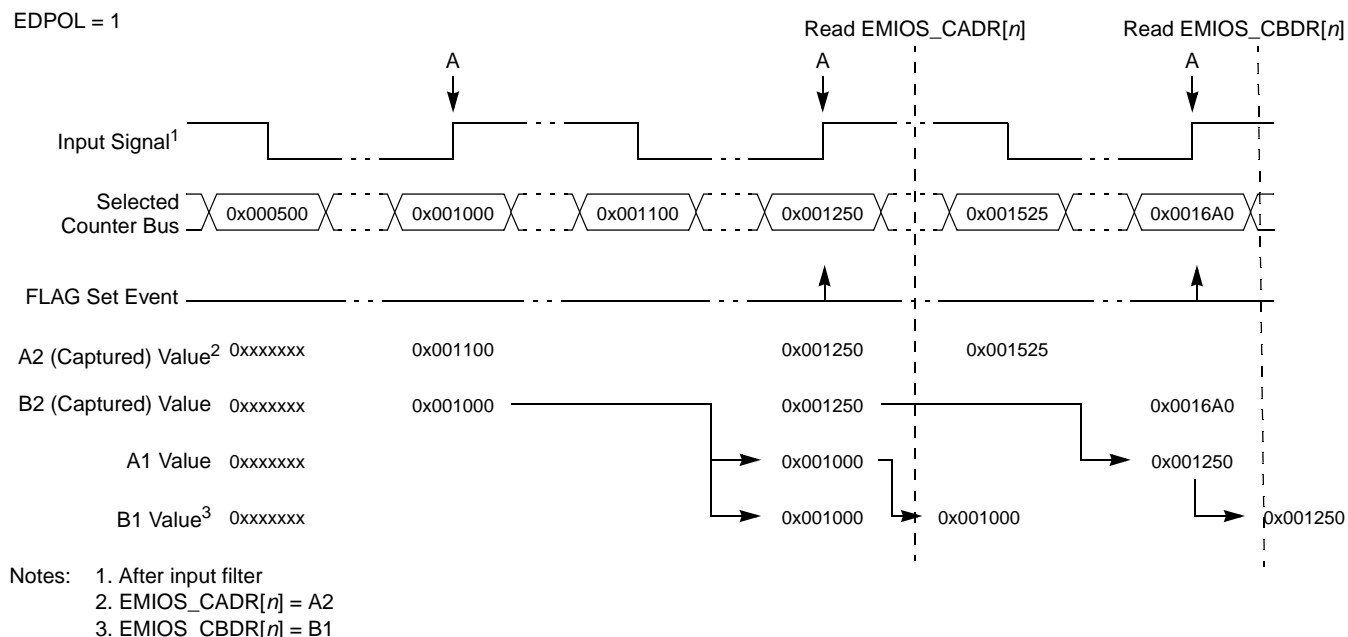

Figure 23-21. A1 and B1 Updates at EMIOS_CADR[n] and EMIOS_CBDR[n] Reads

23.4.1.1.6 Double Action Output Compare (DAOC) Mode

In the DAOC mode the leading and trailing edges of the variable pulse-width output are generated by matches occurring on comparators A and B, respectively.

When the DAOC mode is entered (coming out of GPIO mode), both comparators are disabled and the output flip-flop is set to the complement of the EDPOL bit in the EMIOS_CCR[n] register

Data written to A2 and B2 are transferred to A1 and B1, respectively, on the next system clock cycle if the OU[n] bit in EMIOS_OUDR register is cleared (see [Figure 23-24](#)). The transfer is blocked if the OU[n] bit is set. Comparator A is enabled only after the transfer to A1 register occurs, and is disabled on the next A match. Comparator B is enabled only after the transfer to B1 register occurs, and is disabled on the next B match. Comparators A and B are enabled and disabled independently.

The output flip-flop is set to the value of EDPOL when a match occurs on comparator A and to the complement of EDPOL when a match occurs on comparator B.

MODE[6] controls if the FLAG bit is set on both matches or on the second match only (see [Table 23-9](#) for details). FLAG bit assertion depends on comparator enabling.

If subsequent enabled output compares occur on registers A1 and B1, pulses continue to be generated, regardless of the state of the FLAG bit.

At any time, the FORCMA and FORCMB bits allow the software to force the output flip-flop to the level corresponding to a comparison event in comparator A or B, respectively. The FLAG bit is not affected by these forced operations.

NOTE

If both A1 and B1 registers are loaded with the same value, the B match prevails concerning the output pin state. The output flip-flop is set to the complement of EDPOL, the FLAG bit is set, and both comparators are disabled.

[Figure 23-22](#) and [Figure 23-23](#) show how the unified channel can be used to generate a single output pulse with FLAG bit being set on the second match or on both matches, respectively.

Enhanced Modular Input/Output Subsystem (eMIOS200)

MODE[6] = 0

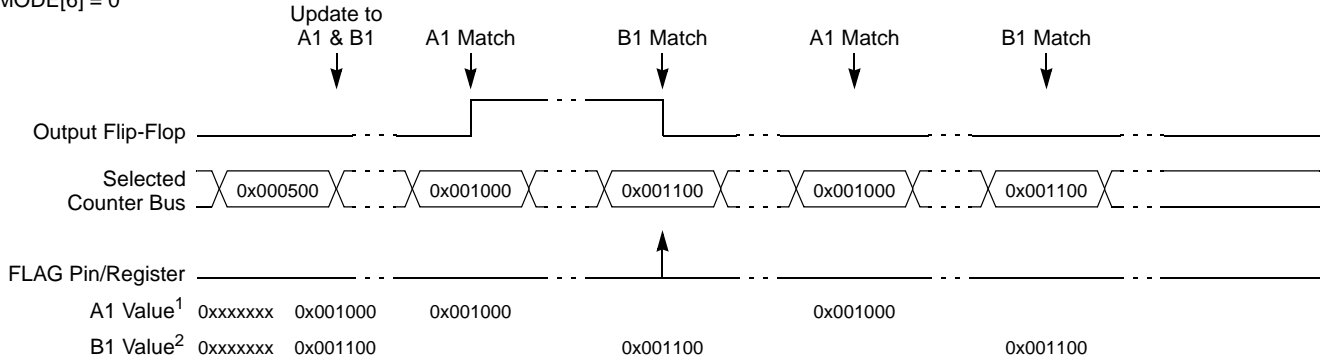

- Notes: 1. EMIOS_CADR[n] = A1
 2. EMIOS_CBDR[n] = B1
 A2 = A1 according to OU[n] bit
 B2 = B1 according to OU[n] bit

Figure 23-22. DAOC with FLAG Set on the Second Match

MODE[6] = 1

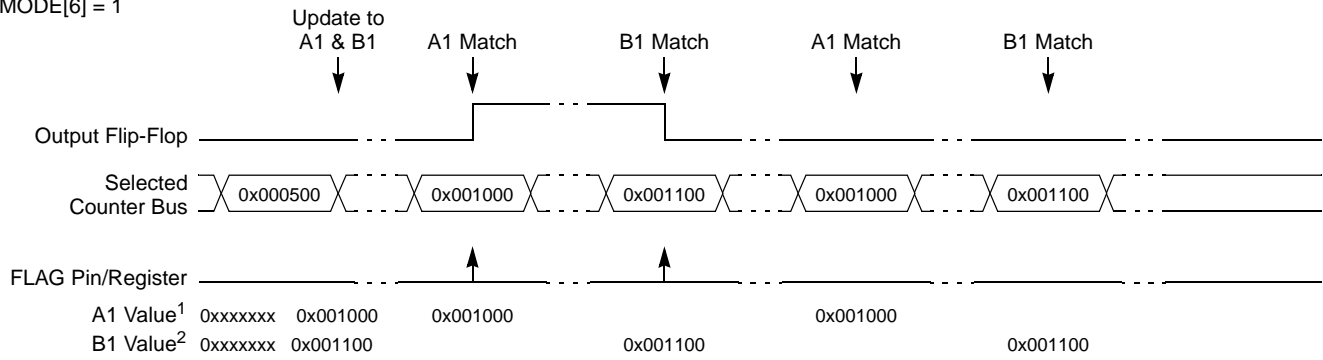

- Notes: 1. EMIOS_CADR[n] = A1
 2. EMIOS_CBDR[n] = B1
 A2 = A1 according to OU[n] bit
 B2 = B1 according to OU[n] bit

Figure 23-23. DAOC with FLAG Set on Both Matches

MODE[6] = 1
 EDSEL = 1
 EDPOL = x

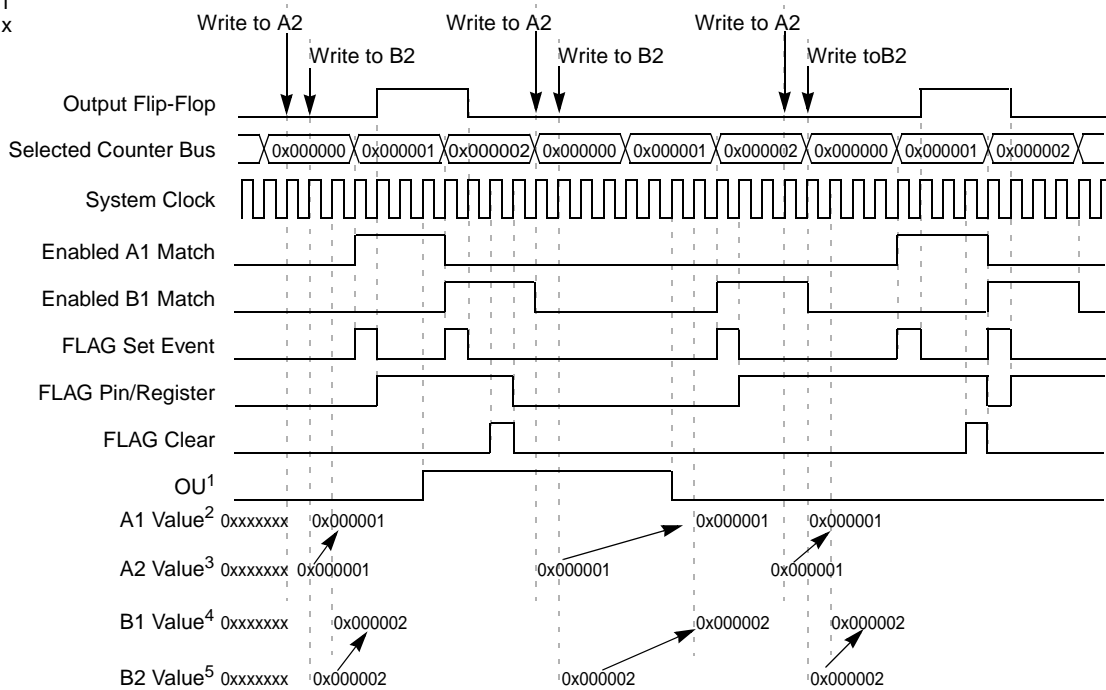

Note: 1. OU[n] bit of EMIOS_OUDR register

2. EMIOS_CADR[n] = A1 (when reading)

3. EMIOS_CADR[n] = A2 (when writing)

4. EMIOS_CBDR[n] = B1 (when reading)

5. EMIOS_CBDR[n] = B2 (when writing)

Figure 23-24. DAOC with Transfer Disabling Example

23.4.1.1.7 Pulse/Edge Accumulation (PEA) Mode

The PEA mode returns the time taken to detect a desired number of input events. The MODE[6] bit selects between continuous or single-shot operation.

After writing to register A1, the internal counter is cleared on the first input event, ready to start counting input events, and the selected timebase is latched into register B2. On the match between the internal counter and register A1, a counter bus capture is triggered to register A2 and B2. The data previously held in register B2 is transferred to register B1 and the FLAG bit is set to indicate that an event has occurred. The desired time interval can be determined by subtracting register B1 from A2. Registers EMIOS_CADR[n] and EMIOS_CBDR[n] return the values in register A2 and B1, respectively.

As part of the coherency mechanism, reading EMIOS_CADR[n] disables transfers from B2 to B1. These transfers are disabled until the next read of the EMIOS_CBDR[n] register. Reading the EMIOS_CBDR[n] register re-enables transfers from B2 to B1, to take effect at the next transfer event, as previously described.¹

1. If B1 was not updated due to B2 to B1 transfer being disabled after reading register EMIOS_CADR[n], further EMIOS_CADR[n] and EMIOS_CBDR[n] reads will not return coherent data until a new bus capture is triggered to registers A2 and B2. This capture event is indicated by the channel FLAG being asserted. If enabled, the FLAG also generates an interrupt.

In order to have coherent data in continuous operation mode, the following steps should be performed, assuming the FLAG bit is initially cleared:

1. Wait for FLAG assertion.
2. Read the EMIOS_CADR[n] register.
3. Read the EMIOS_CBDR[n] register.
4. Clear the FLAG bit.
5. Return to step #1.

Accumulation cycles may be lost if the read is not performed in a timely manner. Whenever the Overrun bit is asserted it means that one or more cycles have been lost.

Triggering of the counter clock (input event) is done by a rising or falling edge or both edges on the input pin. The polarity of the triggering edge is selected by the EDSEL and EDPOL bits in EMIOS_CCR[n] register.

For continuous mode operation (MODE[6] cleared, MODE[0:6] = 000_1000), the counter is cleared on the next input event after a FLAG generation and continues to operate as previously described.

For single-shot operation (MODE[6] set, MODE[0:6] = 000_1001), the counter is not cleared or incremented after a FLAG generation until a new writing operation to register A (EMIOS_CADR) is performed.

Figure 23-25 and Figure 23-26 show how the unified channel can be used for continuous and single-shot pulse/edge accumulation mode.

MODE[6] = 0

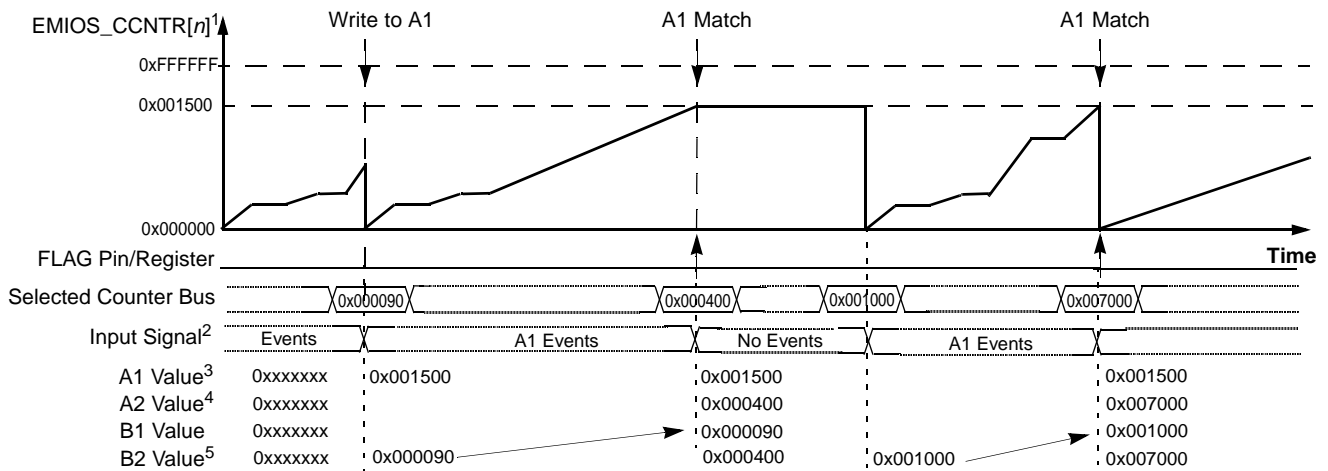

- Notes:
1. Cleared on the first input event after writing to register A1
 2. After input filter
 3. EMIOS_CADR[n] = A1 (when writing)
 4. EMIOS_CADR[n] = A2 (when reading)
 5. EMIOS_CBDR[n] = B1

Figure 23-25. PEA Continuous Mode Example

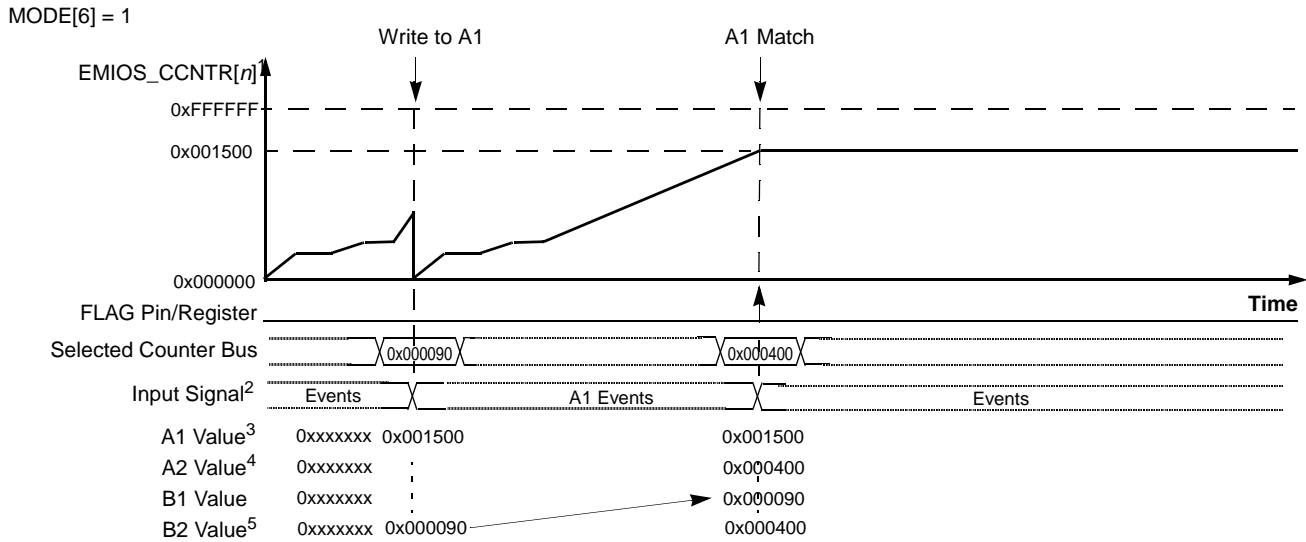

- Notes:
1. Cleared on the first input event after writing to register A1
 2. After input filter
 3. $EMIOS_CADR[n] = A1$ (when writing)
 4. $EMIOS_CADR[n] = A2$ (when reading)
 5. $EMIOS_CBDR[n] = B1$

Figure 23-26. PEA Single-Shot Mode Example

23.4.1.1.8 Pulse/Edge Counting (PEC) Mode

The PEC mode returns the amount of pulses or edges detected on the input for a desired time window. The MODE[6] bit selects between continuous or single-shot operation.

Triggering of the internal counter is done by a rising or falling edge or both edges on the input signal. The polarity and the triggering edge is selected by EDSEL and EDPOL bits in the EMIOS_CCR[n] register.

Register A1 holds the start time and register B1 holds the stop time for the time window. After writing to register A1, when a match occur between comparator A and the selected timebase, the internal counter is cleared and it is ready to start counting input events. When the time base matches comparator B, the internal counter is disabled and its content is transferred to register A2. At the same time the FLAG bit is set. Reading registers EMIOS_CCNTR[n] or A2 returns the amount of detected pulses.

For continuous operation (MODE[6] cleared, MODE[0:6] = 000_1010), the next match between comparator A and the selected time base clears the internal counter and counting is enabled again. In order to guarantee coherent measurements when reading EMIOS_CCNTR[n] after the FLAG is set, the software must check if the time base value is out of the time interval defined by registers A1 and B1. Alternatively register A2 always holds the latest available measurement providing coherent data at any time after the first FLAG had occurred. This register is addressed by the alternate address EMIOS_ALTA[n].

For single-shot operation (MODE[6] set, MODE[0:6] = 000_1011), the next match between comparator A and the selected time base has no effect, until a new write to register A (EMIOS_CADR) is performed. The EMIOS_CCNTR content is also transferred to register A2 when a match in the B comparator occurs.

Figure 23-27 and Figure 23-28 show how the unified channel can be used for continuous or single-shot pulse/edge counting mode.

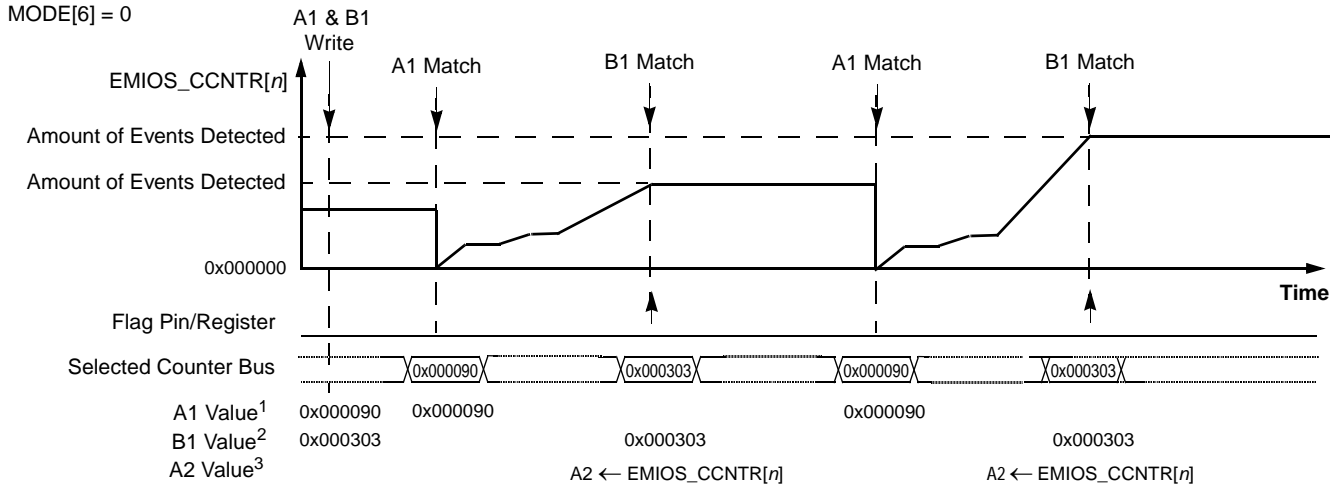

Notes: 1. EMIOS_CADR[n] = A1
 2. EMIOS_CBDR[n] = B1
 3. EMIOS_ALTA[n] = A2

Figure 23-27. PEC Continuous Mode Example

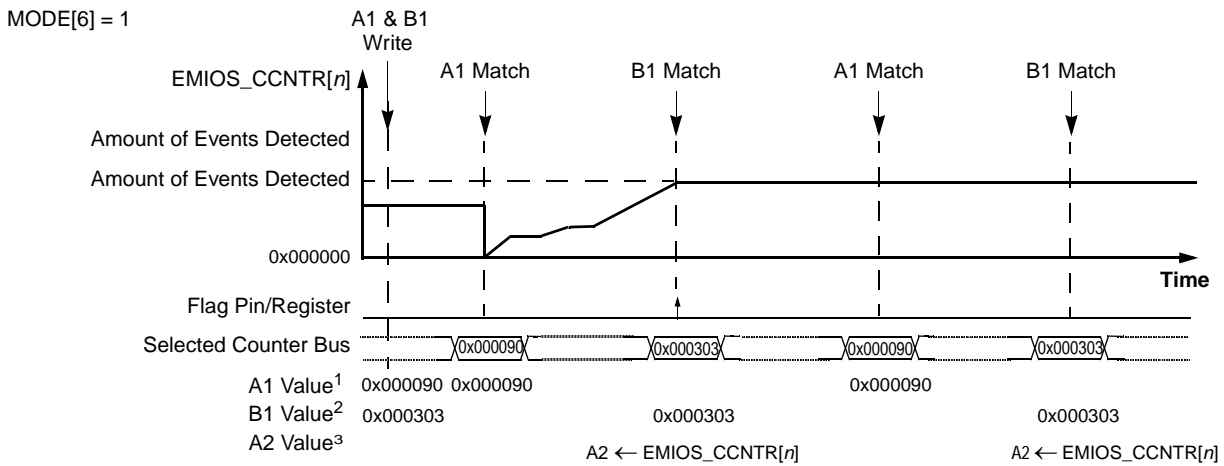

Notes: 1. EMIOS_CADR[n] = A1
 2. EMIOS_CBDR[n] = B1
 3. EMIOS_ALTA[n] = A2

Figure 23-28. PEC Single-Shot Mode Example

23.4.1.1.9 Quadrature Decode (QDEC) Mode

QDEC mode uses UC[n] operating in QDEC mode and the input programmable filter (IPF) from UC[n - 1]. Note that UC[n - 1] can be configured, at the same time, to an operation mode that does not use I/O pins, such as modulus counter mode (MC). The connection among the unified channels is circular, i.e., when UC[0] is running in QDEC mode, the input programmable filter from UC[31] is being used.

This mode generates a FLAG every time the internal counter matches A1 register. The internal counter is automatically selected and is not cleared when entering this mode.

MODE[6] bit selects which type of encoder is used: *count & direction* encoder or *phase_A & phase_B* encoder.

When operating with *count & direction* encoder (MODE[6] cleared), the UC[n] input pin must be connected to the *direction* signal and the UC[n - 1] input pin must be connected to the count signal of the quadrature encoder. The EDPOL bit for UC[n] selects the count direction according to the *direction* signal and the EDPOL bit for UC[n - 1] selects whether the internal counter is clocked by the rising or falling edge of the *count* signal.

When operating with *phase_A & phase_B* encoder (MODE[6] set), the UC[n] input pin must be connected to the *phase_A* signal and the UC[n - 1] input pin must be connected to the *phase_B* signal of the quadrature encoder. The EDPOL bit selects the count direction according to the phase difference between *phase_A & phase_B* signals.

Figure 23-29 and Figure 23-30 show two unified channels configured to quadrature decode mode for *count & direction* encoder and *phase_A & phase_B* encoders, respectively.

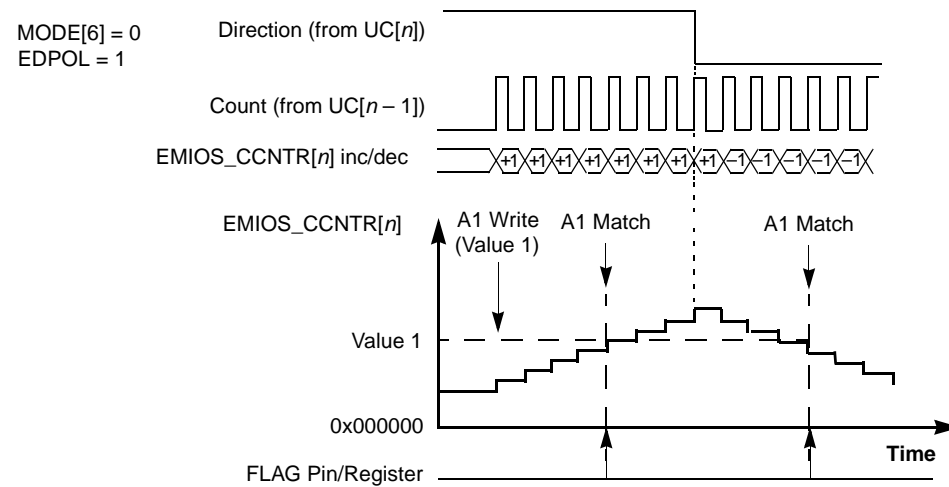

Note: EMIOS_CADR[n] ≥ A1

Figure 23-29. QDEC Mode Example with *Count & Direction* Encoder

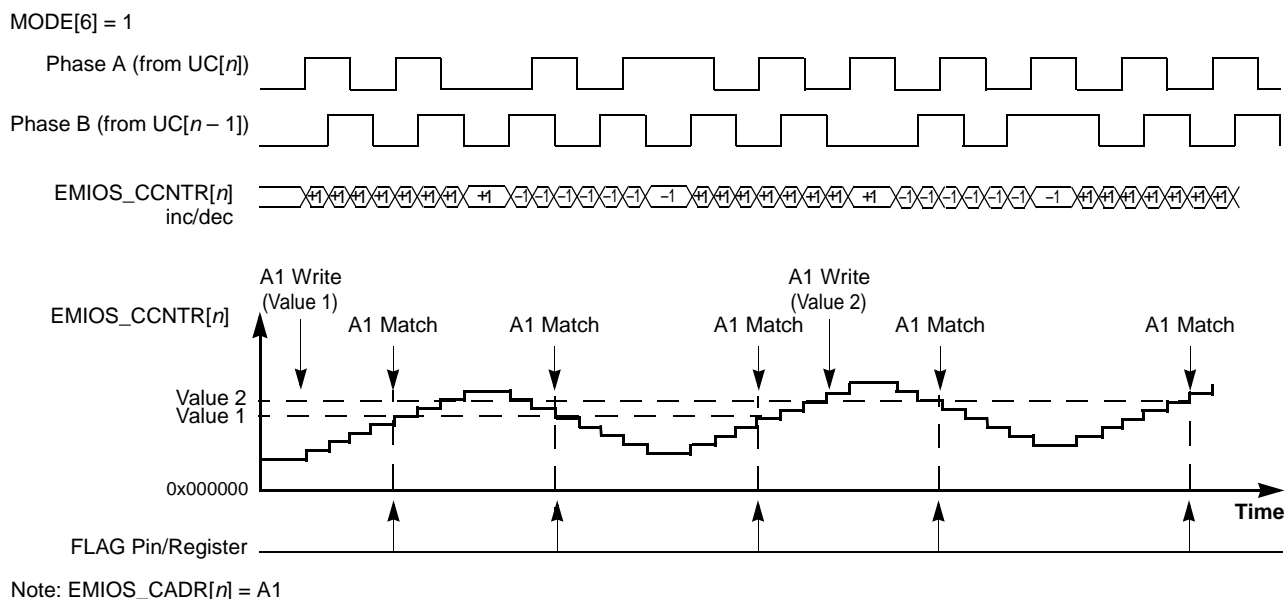

Figure 23-30. QDEC Example with *Phase_A* & *Phase_B* Encoder

23.4.1.1.10 Windowed Programmable Time Accumulation (WPTA) Mode

The WPTA mode (MODE = 000_1110) accumulates the sum of the total high time or low time of an input signal over a programmable interval (time window).

The UCPRE[1:0] prescaler bits in the EMIOS_CCR[n] register define the increment rate of the internal counter.

Register A1 holds the start time and register B1 holds the stop time of the programmable time interval. When a match occurs between register A (EMIOS_CADR) and the selected timebase, the internal counter is cleared and it is ready to start counting. The internal counter is used as a time accumulator, i.e., it counts up when the input signal has the same polarity of the EDPOL bit in the EMIOS_CCR[n] register and does not count otherwise. When a match occurs in comparator B, the internal counter is disabled regardless of the input signal polarity and the FLAG bit is set. At the same time, the contents of the EMIOS_CCNTR[n] register is transferred to register A2. Reading registers EMIOS_CCNTR[n] or A2 returns the high or low time of the input signal.

Note that EMIOS_CCNTR[n] is stable only outside the time window defined from A1 to B1 matches. Otherwise, its contents reflect a count in progress and not the final value. Alternatively to EMIOS_CCNTR[n], register A2 returns the latest available measurement. Since this register is updated only at comparator B matches, it always contains stable and up-to-date data. In this mode, this register is accessible through the alternate register address EMIOS_ALTA[n].

Figure 23-31 shows how the unified channel can be used to accumulate high time.

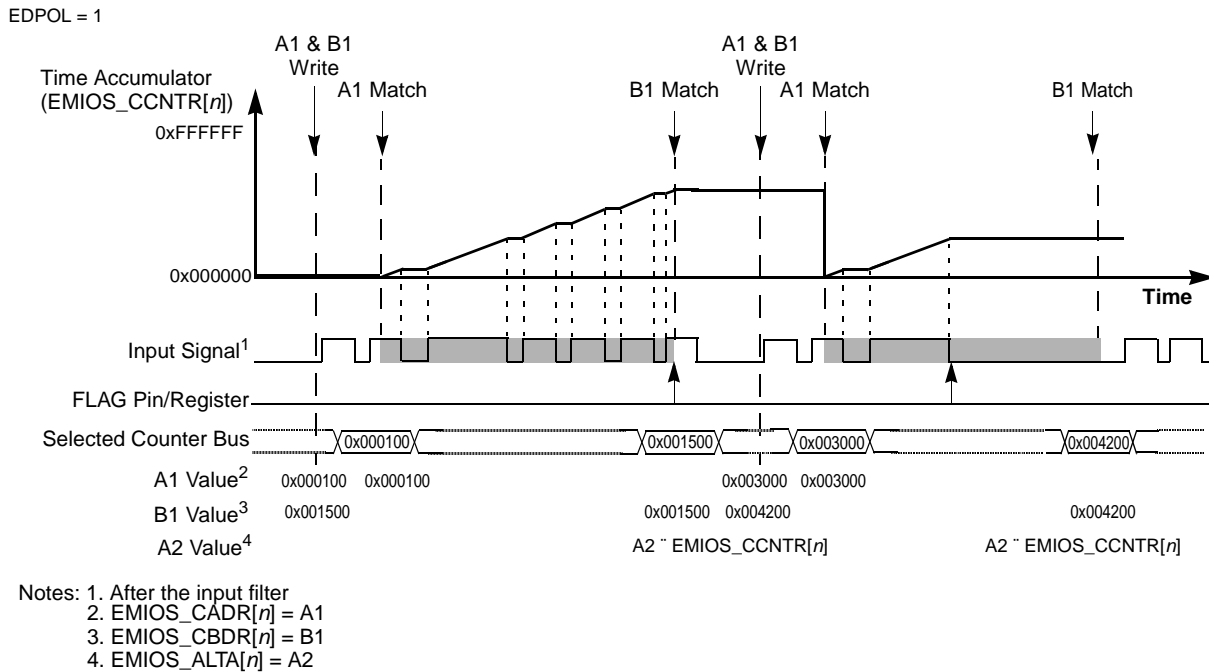

Figure 23-31. WTPA Example

23.4.1.1.11 Modulus Counter (MC) Mode

The MC mode can be used to provide a time base for a counter bus or as a general purpose timer.

The MODE[6] bit selects the internal or external clock source when cleared or set, respectively. When the external clock is selected, the input signal pin is used as the source and the triggering polarity edge is selected by the EDPOL and EDSEL bits in the EMIOS_CCR[n] register.

The internal counter counts up from the current value until it matches the value in register A1. Register B1 is cleared and is not accessible to the MCU. The MODE[4] bit selects up mode or up/down mode, when cleared or set, respectively.

When in up count mode, a match between the internal counter and register A1 sets the FLAG and clears the internal counter. The timing of those events varies according to the MC mode setup as follows:

- Internal counter clearing on match start (MODE = 001_000b)
 - When MODE[6] is set, the external clock is selected. In this case, the internal counter clears as soon as the match signal occurs. The channel FLAG bit is set at the same time the match occurs. Note that by having the internal counter cleared as soon as the match occurs and incremented at the next input event, a shorter zero count is generated. See [Figure 23-61](#) and [Figure 23-63](#).
 - When MODE[6] is cleared, the internal clock source is selected. In this case, the counter clears as soon as the match signal occurs. The channel FLAG bit is set at the same time the match occurs. At the next prescaler tick after the match, the internal counter remains at 0 and only resumes counting on the following tick. See [Figure 23-61](#) and [Figure 23-64](#).
- Internal counter clearing on match end (MODE = 001_001b)

- When MODE[6] is set, the external clock is selected. In this case, the internal counter clears when the match signal is asserted and the input event occurs. The channel FLAG bit is set at the same time the counter is cleared. See [Figure 23-61](#) and [Figure 23-65](#).
- When MODE[6] is cleared, the internal clock source is selected. In this case, the internal counter clears when the match signal is asserted and the prescaler tick occurs. The channel FLAG bit is set at the same time the counter is cleared. See [Figure 23-61](#) and [Figure 23-65](#).

NOTE

If the internal clock source is selected and the prescaler of the internal counter is set to 1, the MC mode behaves the same way even in Clear on Match Start or Clear on Match End sub-modes.

When in up/down count mode (MODE = 001_01bb), a match between the internal counter and register A1 sets the FLAG and changes the counter direction from increment to decrement. A match between register B1 and the internal counter changes the counter direction from decrement to increment and sets the FLAG only if MODE[5] bit is set.

Only values other than 0x00_0000 must be written into register A (EMIOS_CADR). Loading 0x00_0000 leads to unpredictable results.

Updates on register A (EMIOS_CADR) or the counter in MC mode may cause a loss of match in the current cycle if the transfer occurs near the match. In this case, the counter may roll over and resume operation in the next cycle.

[Figure 23-32](#) and [Figure 23-33](#) show how the unified channel can be used as a modulus counter in up mode and up/down mode, respectively.

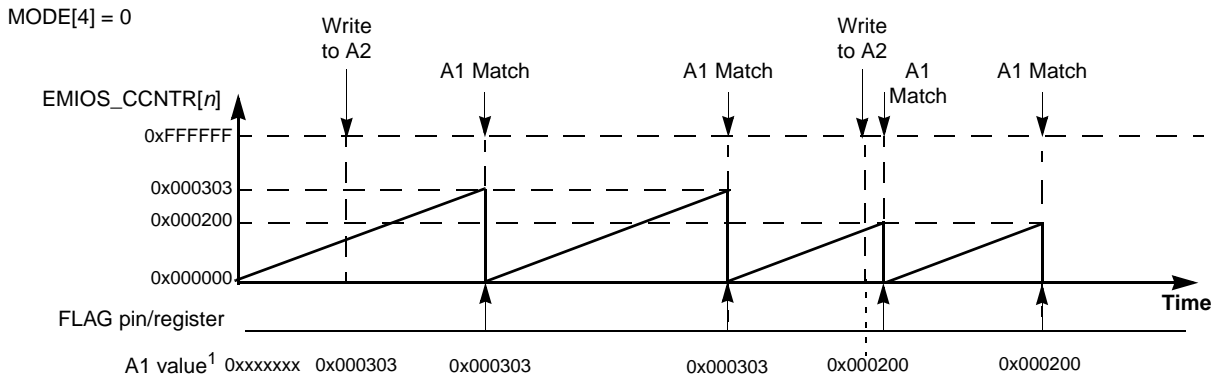

Notes: 1. EMIOS_CADR[n] = A1
A2 = A1 according to OU[n] bit

Figure 23-32. MC Up Mode Example

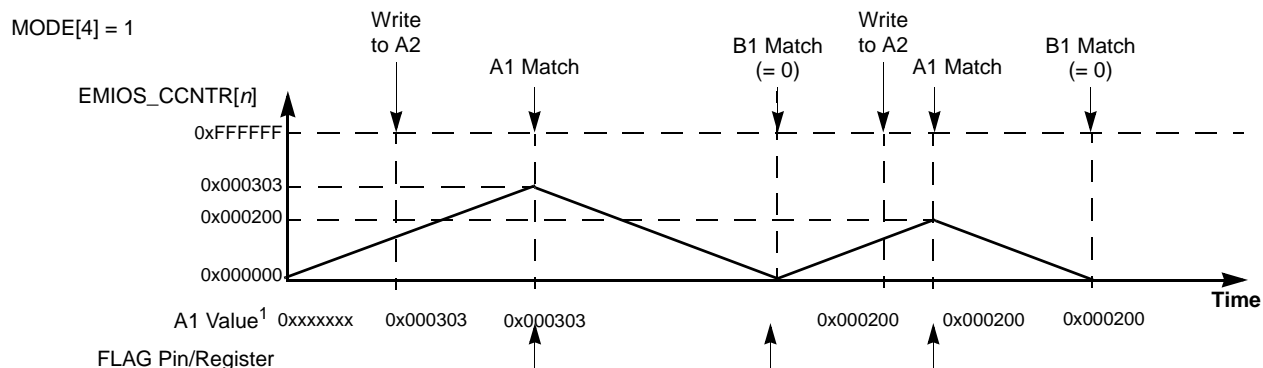

Notes: 1. EMIOS_CADR[n] = A1
A2 = A1 according to OU[n] bit

Figure 23-33. MC Up/Down Mode Example

23.4.1.1.12 Modulus Counter Buffered (MCB) Mode

The MCB mode provides a time base that can be shared with other channels through the internal counter buses. Register A1 is double-buffered, thus allowing smooth transitions between cycles when changing the A2 register value on the fly. Register A1 is updated at the cycle boundary, which is defined as when the internal counter reaches the value 0x00_0001.

The internal counter values operate within a range from 0x00_0001 up to the value of register A1 in MCB mode. When entering MCB mode (coming out of GPIO mode), the internal counter value must be within that range. Otherwise, the first A match will not occur, causing the channel internal counter to wrap at the maximum counter value of 0xFF_FFFF. After the counter wrap occurs, it returns to 0x00_0001 and resumes normal MCB mode operation. To avoid this counter wrap condition, make sure the internal counter value is within the 0x00_0001 to A1 register value range when entering the MCB mode.

MODE[6] bit selects the internal clock source if set to 0, or external if set to 1. When the external clock is selected, the input channel pin is used as the channel clock source. The active edge of this clock is defined by the EDPOL and EDSEL bits in the EMIOS_CCR[n] channel register.

When entering MCB mode, if the up counter is selected by MODE[4] = 0, the internal counter starts counting up from its current value until the A1 match occurs. On the next system clock cycle after the A1 match, the internal counter is set to 0x00_0001 and the FLAG bit is set to '1'.

If the up/down counter is selected by setting MODE[4] = 1, the counter changes direction at the A1 match and counts down until it reaches 0x00_0001. After it reaches 0x00_0001, it counts up again. Register B1 is set to 0x00_0001 on entering MCB mode cannot be changed while this mode is selected. B1 is used to generate a match to set the internal counter in up-count direction if up/down mode is selected.

The MCB mode counts between 0x00_0001 and the value in the A1 register. Only values greater than 0x00_0001 are allowed to be written to the A1 register. Loading values other than those leads to unpredictable results. The counter cycle period is equal to A1 value in up counter mode. If in up/down counter mode the period is defined by the expression: $(2 \times A1) - 2$.

Figure 23-34 shows the counter cycle for several A1 values. Register A1 is loaded with the value in A2 at the cycle boundary. Any value written to the A2 register within cycle (n) is updated to A1 at the next cycle

boundary and therefore is used on cycle $(n + 1)$. The cycle boundary between cycle (n) and cycle $(n + 1)$ is defined as the first system clock cycle of cycle $(n + 1)$. The flags are generated as soon as the A1 match occurs.

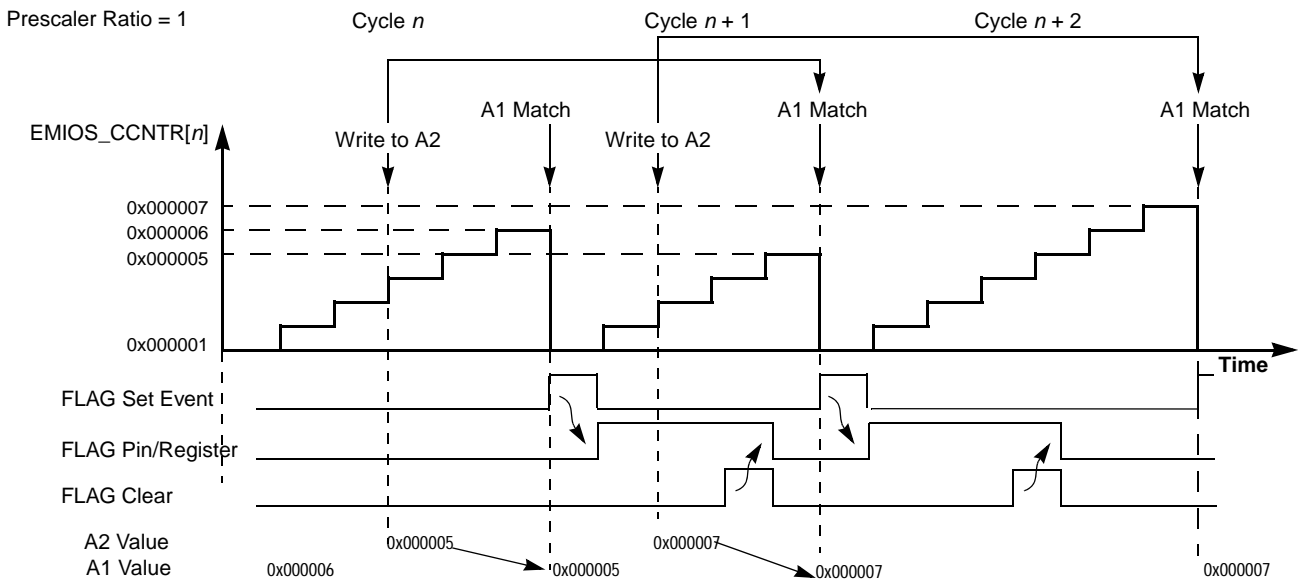

Figure 23-34. Modulus Counter Buffered (MCB) Up Count Mode

Figure 23-35 shows the MCB in up/down counter mode. Register A1 is updated at the cycle boundary. If A2 is written in cycle (n) , this new value is used in cycle $(n + 1)$ for an A1 match. When MODE[5] is cleared, flags are generated only on an A1 match. If MODE[5] is set to 1, flags are also generated at the cycle boundary.

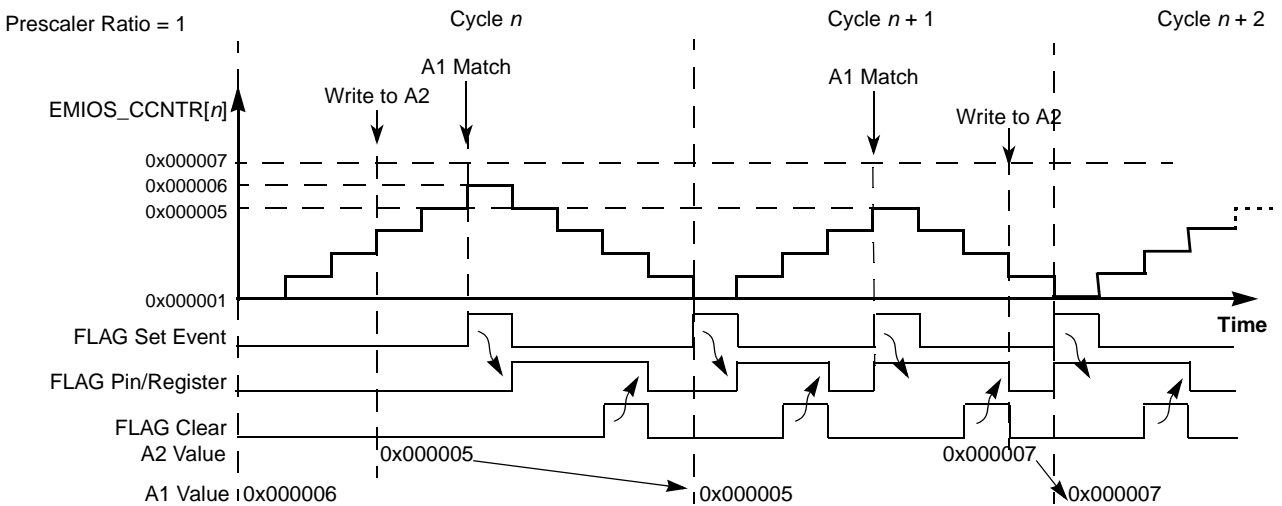

Figure 23-35. MCB Up/Down Mode

Figure 23-36 shows the A1 register update process in up counter mode. The A1 load signal is generated at the last system clock period of a counter cycle.

The A1 load signal is generated based on the detection of the internal counter reaching 0x00_0001 and has the duration of one system clock cycle. During the load pulse, A1 still holds its previous value. It is updated at the second system clock cycle only. Thus, A1 is updated with A2 value at the same time that the counter (EMIOS_CCNTR[n]) is loaded with 0x00_0001. The load signal pulse has the duration of one system clock period. If A2 is written within cycle (n), its value is available at A1 at the first clock of cycle (n + 1) and the new value is used for match at cycle (n + 1). The update disable bits OU[n] of the EMIOS_OUDR register can be used to control the update of this register, thus allowing the A1 register update to be delayed for synchronization purposes.

Prescaler Ratio = 2

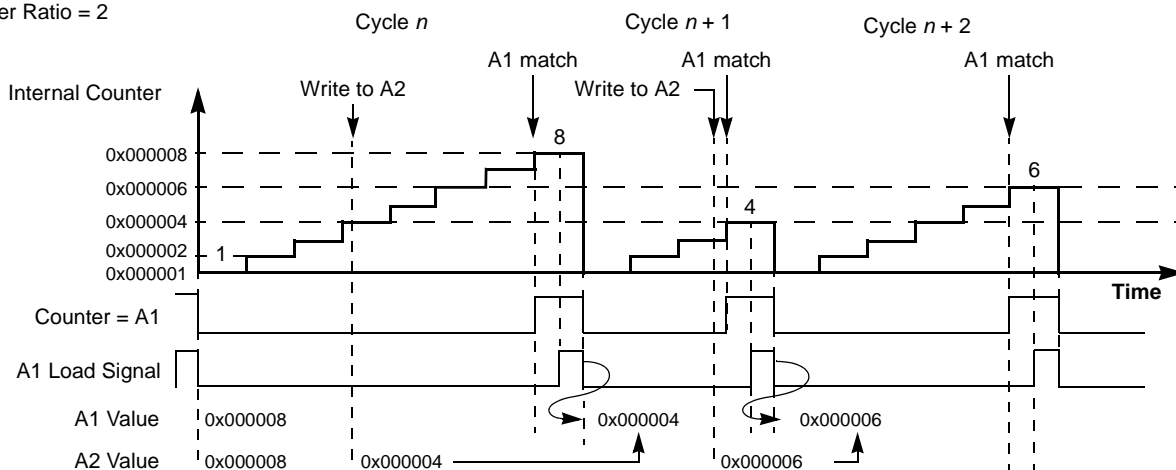

Figure 23-36. MCB Mode A1 Register Update in Up Counter Mode

Figure 23-37 shows the A1 register update in up/down counter mode. Note that A2 can be written at any time within cycle (n) in order to be used in cycle (n + 1). Thus A1 receives this new value at the next cycle boundary. The update disable bits (OU[n] in EMIOS_OUDR) can be used to disable the update of A1 register.

Prescaler Ratio = 2

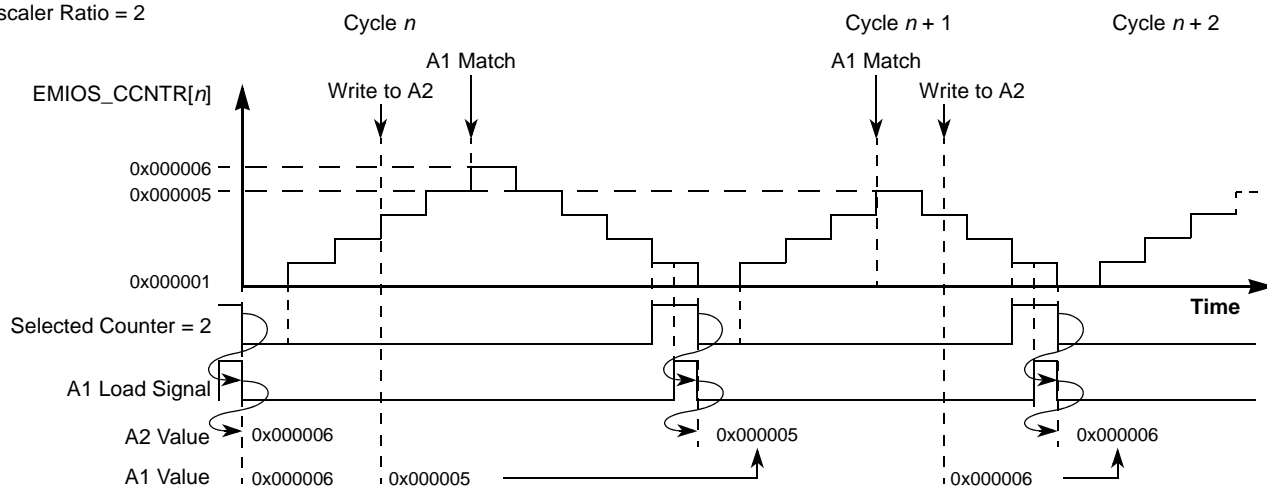

Figure 23-37. MCB Mode A1 Register Update in Up/Down Counter Mode

23.4.1.1.13 Output Pulse Width and Frequency Modulation (OPWFM) Mode

In the OPWFM mode, the duty cycle of the output signal is the value defined in register A1 plus 0x1, and the period is the value defined in register B1 plus 0x1. MODE[6] bit controls the transfer from register B2 to B1, which can be done either immediately (MODE[6] cleared, MODE = 00110b0), providing the fastest change in the duty cycle, or at every match of register A1 (MODE[6] set, MODE = 00110b1).

When OPWFM mode is entered, coming out from GPIO mode, the output flip-flop is set to the complement of the EDPOL bit in the EMIOS_CCR[n] register.

The internal counter is automatically selected as a time base, therefore the BSL[1:0] bits in register EMIOS_CCR[n] have no meaning. When a match on comparator A occurs, the output flip-flop is set to the value of the EDPOL bit. When a match occurs on comparator B, the output flip-flop is set to the complement of the EDPOL bit and the internal counter is cleared.

FLAG can be generated at match B, when MODE[5] is cleared, or in both matches, when MODE[5] is set.

At any time, the FORCMA and FORCMB bits allow the software to force the output flip-flop to the level corresponding to a match on A or B respectively. Also, FORCMB clears the internal counter. Note that the FLAG bit is not set by the FORCMA or FORCMB operations.

If subsequent comparisons occur on comparators A and B, the PWFPM pulses continue to be output, regardless of the state of the FLAG bit.

In order to achieve 100% duty cycle, both registers A1 and B1 must be set to the same value. When a simultaneous match occurs on comparators A and B, the output flip-flop is set to the value of EDPOL bit. 0% duty cycle is possible by writing 0x0 to register A (EMIOS_CADR). When a match occurs, the output flip-flop is set at every period to the complement of EDPOL bit. The transfer from register B2 to B1 is still controlled by MODE[6] bit.

NOTE

Writing 0x0 to A1 and B1 produces a duty cycle of 0%.

Figure 23-38 shows the unified channel running in OPWFM mode with immediate register update and Figure 23-39 shows the unified channel running in OPWFM mode with next period update.

MODE[6] = 0

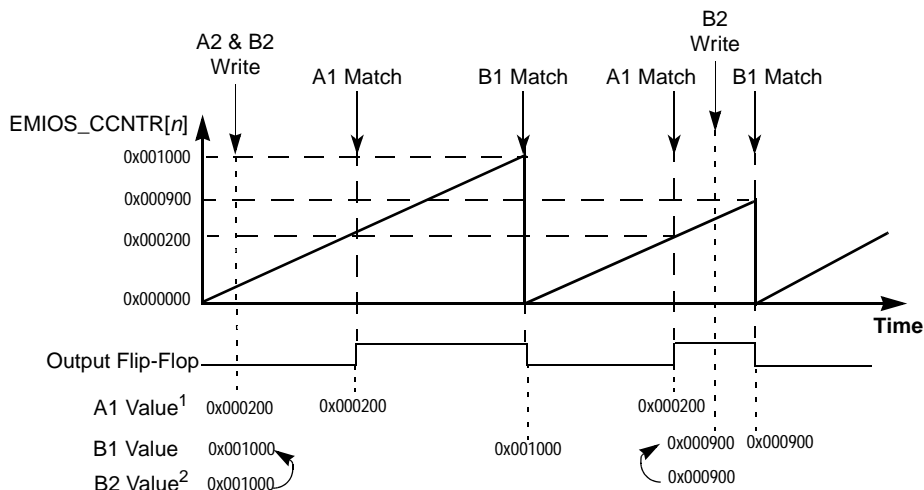

Notes: 1. EMIOS_CADR[n] = A1
 2. EMIOS_CBDR[n] = B2
 A2 = A1 according to OU[n] bit
 B2 = B1 according to OU[n] bit

Figure 23-38. OPWFM with Immediate Update

MODE[6] = 1

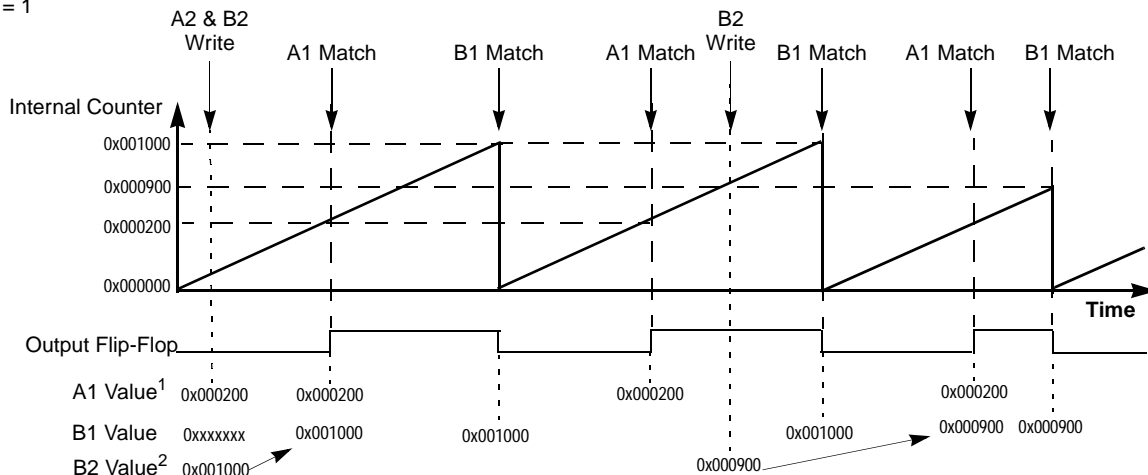

Notes: 1. EMIOS_CADR[n] = A1
 2. EMIOS_CBDR[n] = B2
 A2 = A1 according to OU[n] bit
 B2 = B1 according to OU[n] bit

Figure 23-39. OPWFM with Next Period Update

23.4.1.1.14 Output Pulse-Width and Frequency Modulation Buffered (OPWFMB) Mode

The OPWFMB mode provides waveforms with variable duty cycle and frequency. The internal channel counter is automatically selected as the time base when this mode is selected. The A1 register indicates the duty cycle and the B1 register indicates the frequency. Both A1 and B1 registers are double-buffered to allow smooth signal generation when changing the registers values on the fly. This mode supports 0% and 100% duty cycles.

At OPWFMB mode entry, the output flip-flop is set to the value of the EDPOL bit in the EMIOS_CCR[n] register.

To provide smooth and consistent channel operation, this mode differs substantially from the OPWFM mode. The main differences reside in the A1 and B1 registers update, on the delay from the A1 match to the output pin transition, and on the internal counter values, which range from 0x00_0001 up to the value in register B1.

When entering OPWFMB mode (coming out of GPIO mode), if the internal counter value is not within that range, then the B match will not occur, causing the channel internal counter to wrap at the maximum counter value which is 0xFF_FFFF. After the counter wrap occurs, the value returns to 0x00_0001 and the counter resumes normal OPWFMB mode operation. Thus in order to avoid the counter wrap condition, make sure its initial value is within the range between 0x00_0001 and the B1 register value the OPWFMB mode is entered.

When a match on comparator A occurs, the output register is set to the value of EDPOL. When a match on comparator B occurs, the output register is set to the complement of EDPOL. B1 match also causes the internal counter to transition to 0x00_0001, thus restarting the counter cycle.

Only values greater than 0x00_0001 are allowed to be written to the B1 register. Loading values other than those leads to unpredictable results.

Figure 23-40 shows the operation of the OPWFMB mode regarding output pin transitions and A1/B1 registers match events. The output pin transition occurs when the A1 or B1 match signal is deasserted, which is indicated by the A1 match negative edge detection signal. If register A1 is set to 0x00_0004, the output pin transitions four counter periods after the cycle has started, plus one system clock cycle. In the example shown in Figure 23-40 the internal counter prescaler has a ratio of two.

Prescaler Ratio = 2
EDPOL = 0

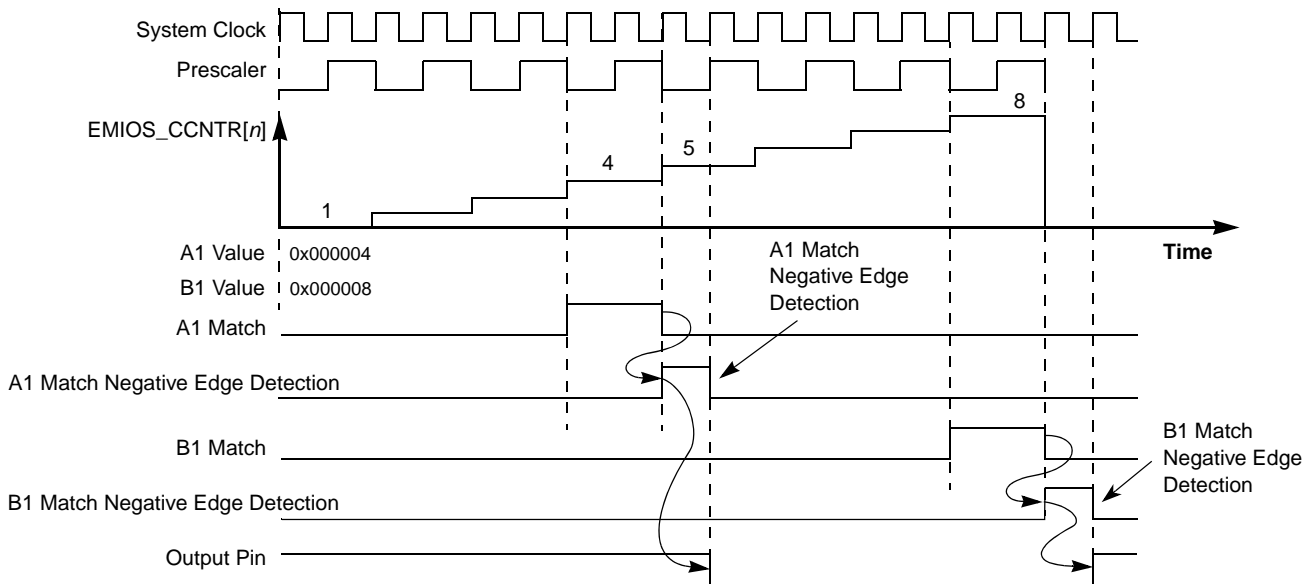

Figure 23-40. OPWFMB A1 and B1 Match to Output Register Delay

Figure 23-41 shows the generated output signal if A1 is set to 0x0. Because the counter does not reach 0 in this mode, the channel internal logic infers a match as if A1 = 0x00_0001 with the difference that in this case, the positive edge of the match signal is used to trigger the output pin transition instead of the negative edge used when A1 = 0x00_0001. An A1 positive edge match signal from cycle ($n + 1$) occurs at the same time as B1 negative edge match signal from cycle (n). This allows using the A1 positive edge match to mask the B1 negative edge match when they occur at the same time. The result is that no transition occurs on the output flip-flop and a 0% duty cycle is generated.

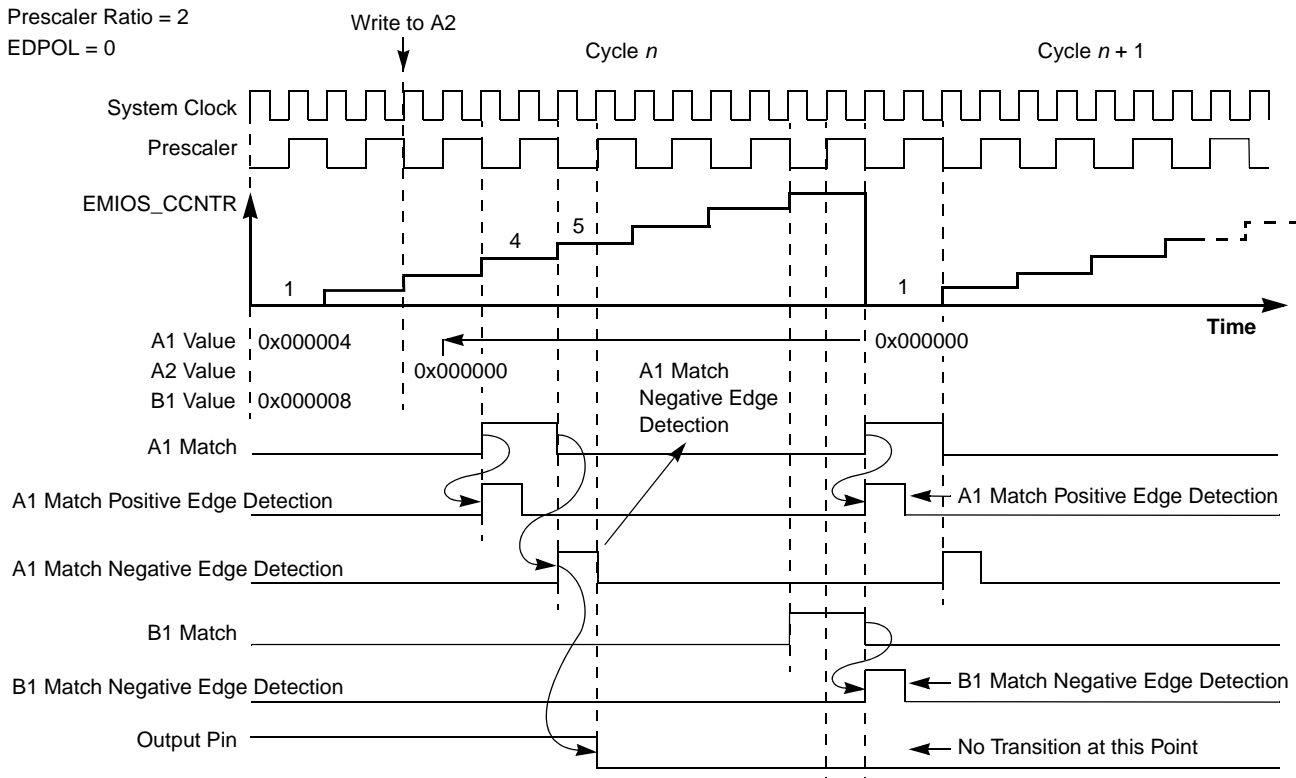

Figure 23-41. OPWFMB Mode with A1 = 0 (0% duty cycle)

Figure 23-42 shows the timing for the A1 and B1 registers load. The A1 and B1 load use the same signal which is generated at the last system clock period of a counter cycle. Thus, A1 and B1 are updated respectively with A2 and B2 values at the same time that the EMIOS_CCNTR[n] counter is loaded with 0x00_0001. This event is defined as the cycle boundary. The load signal pulse has the duration of one system clock period. If A2 and B2 are written within cycle (n), their values are loaded into A1 and B1, respectively, at the first clock of cycle ($n + 1$) and the new values are used for matches at cycle ($n + 1$). The update disable bits (OU[n] in EMIOS_OUDR) can be used to control the update of these registers, thus allowing to delay the A1 and B1 registers update for synchronization purposes.

In Figure 23-42, it is assumed that both the channel and global prescalers are set to 0x00_0001 (each divide ratio is two), meaning that the channel internal counter transitions at every four system clock cycles. FLAGS can be generated only on B1 matches when MODE[5] is cleared, or on either A1 or B1 matches when MODE[5] is set. Because the B1 FLAG occurs at the cycle boundary, this flag can be used to indicate that A2 or B2 data written on cycle (n) were loaded to A1 or B1, respectively, thus generating matches in

cycle ($n + 1$). Note that the FLAG has a synchronous operation, meaning that it is asserted one system clock cycle after the FLAG set event.

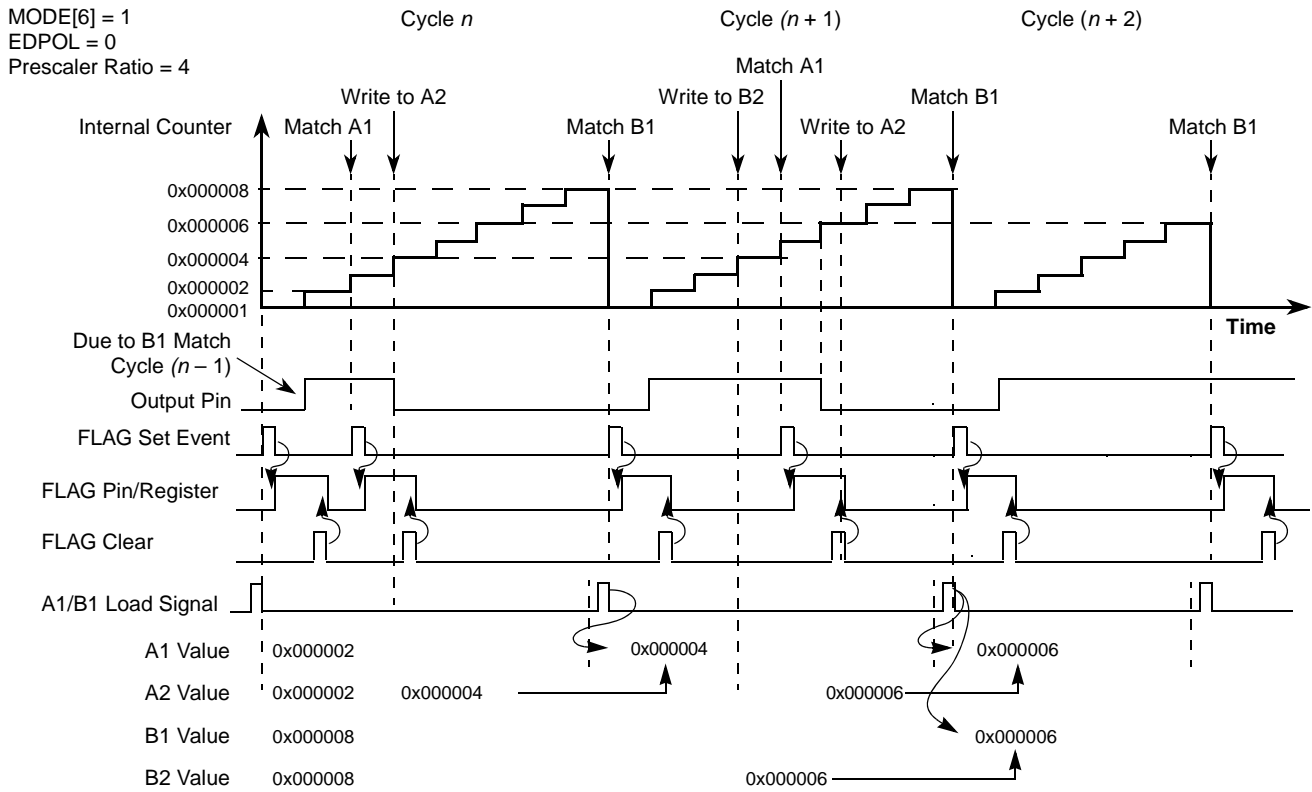

Figure 23-42. OPWFMB A1 and B1 Registers Update and Flags

Figure 23-43 shows the operation of the output disable feature in OPWFMB mode. In contrast to the OPWFM mode, the output disable forces the channel output flip-flop to the value of the EDPOL bit. This functionality targets applications that use active-high signals and a high-to-low transition at A1 match. In this case, EDPOL should be set to 0. Note that both the channel and global prescalers are set to 0x00_0000 (each divide ratio is one), meaning that the channel internal counter transitions at every system clock cycle.

MODE[6] = 1
 EDPOL = 0
 Prescaler Ratio = 1

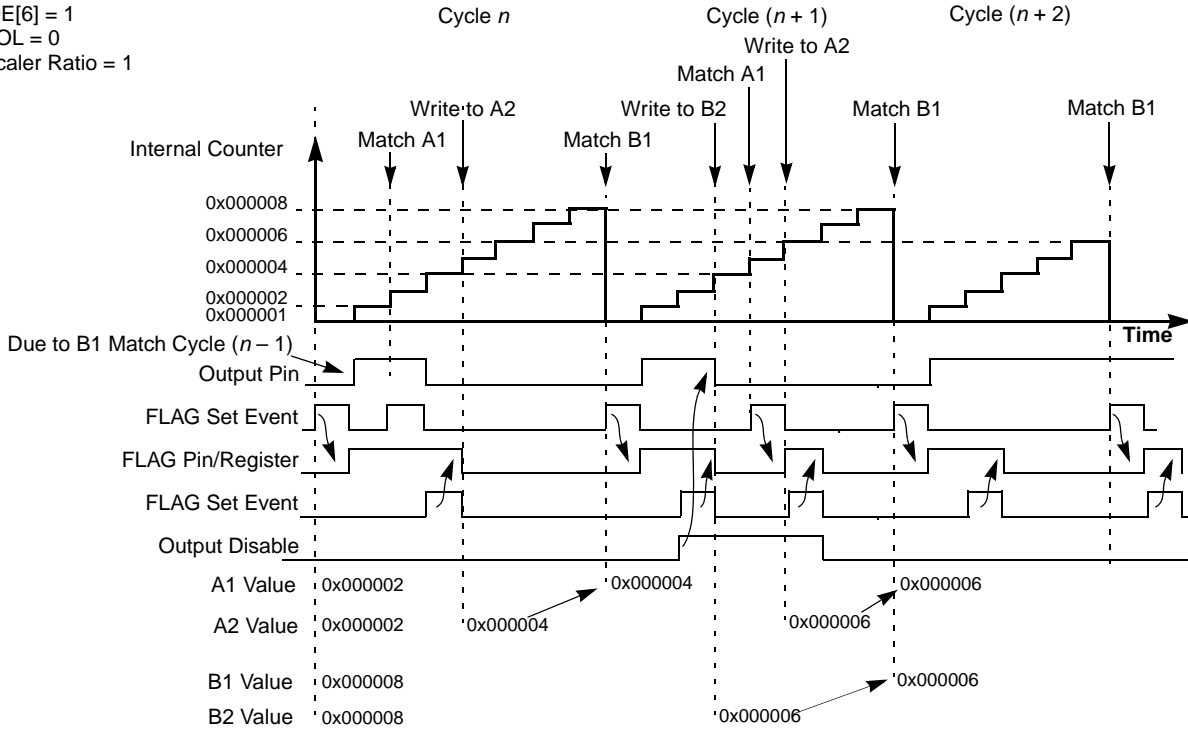

Figure 23-43. OPWFMB Mode with Active Output Disable

The output disable has a synchronous operation, meaning that the assertion of the output disable input pin causes the channel output flip-flop to transition to EDPOL at the next system clock cycle. If the output disable input is deasserted the output pin transition at the following A1 or B1 match.

In [Figure 23-43](#) it is assumed that the output disable input is enabled and selected for the channel. Refer to [Section 23.3.2.7, eMIOS200 Control Register \(EMIOS_CCR\[n\]\)](#), for a description of how the ODIS and ODISSL bits enable and select the output disable inputs.

The FORCMA and FORCMB bits allow the software to force the output flip-flop to the level corresponding to a match on comparators A or B, respectively. Similar to a B1 match, FORCMB sets the internal counter to 0x00_0001. The FLAG bit is not set by the FORCMA or FORCMB bits being asserted.

[Figure 23-44](#) shows the generation of 100% and 0% duty cycle signals. It is assumed EDPOL = 0 and the resultant prescaler value is 1. Initially, A1 = 0x00_0008 and B1 = 0x00_0008. In this case, the B1 match has precedence over the A1 match, thus the output flip-flop is set to the complement of EDPOL bit. This cycle corresponds to a 100% duty cycle signal. The same output signal can be generated for any A1 value greater or equal to B1.

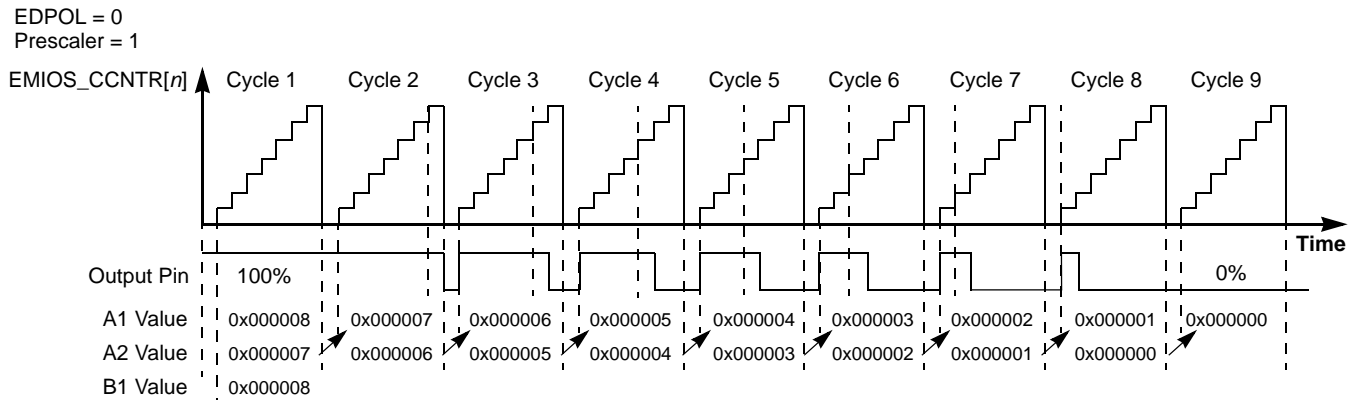

Figure 23-44. OPWFB Mode from 100% to 0% Duty Cycle

A 0% duty cycle signal is generated if A1 = 0x00_0000 as shown in cycle 9 in Figure 23-44. In this case, the B1 = 0x00_0008 match from cycle 8 occurs at the same time as the A1 = 0x00_0000 match from cycle 9. Refer to Figure 23-41 for a description of the A1 and B1 match generation. In this case, the A1 match has precedence over the B1 match and the output signal transitions to EDPOL.

23.4.1.1.15 Center Aligned Output Pulse Width Modulation with Dead Time (OPWMC) Mode

The OPWMC mode generates a center aligned PWM with dead time insertion in the leading (MODE = 001_11b1) or trailing edge (MODE = 001_11b0).

The selected counter bus must be running an up/down time base, as shown in Figure 23-33. BSL[1:0] bits select the time base. Register A1 contains the ideal duty cycle for the PWM signal and is compared with the selected time base. Register B1 contains the dead time value and is compared with the internal counter. For a leading-edge dead time insertion, the output PWM duty cycle is equal to the difference between register A1 and register B1, and for a trailing edge dead time insertion, the output PWM duty cycle is equal to the sum of register A1 and register B1. Mode[6] bit selects between trailing and leading dead time insertion.

NOTE

The internal counter may be running in the internal prescaler ratio, while the selected time base may be running in a different prescaler ratio. The output signal may produce an unexpected output if the dead time interval is greater than the duty cycle of the PWM signal.

When OPWMC mode is entered, coming out from GPIO mode, the output flip-flop is set to the complement of the EDPOL bit in the EMIOS_CCR[n] register.

When operating with leading edge dead time insertion, the first match between A1 and the selected time base clears the internal counter and switches the selected time base to the internal counter. When a match occurs between register B1 and the selected time base, the output flip-flop is set to the value of the EDPOL bit and the time base is switched to the selected counter bus. In the next match between register A1 and the selected time base, the output flip-flop is set to the complement of the EDPOL bit. This sequence repeats continuously.

When operating with trailing edge dead time insertion, the first match between A1 and the selected time base sets the output flip-flop to the value of the EDPOL bit. In the next match between register A1 and the selected time base, the internal counter is cleared and the selected time base is switched to the internal counter. When a match occurs between register B1 and the selected time base, the output flip-flop is set to the complement of the EDPOL bit and the time base is switched to the selected counter bus. This sequence repeats continuously.

FLAG can be generated in the trailing edge of the output PWM signal when MODE[5] is cleared, or in both edges, when MODE[5] is set.

At any time, the FORCMA or FORCMB bits are equivalent to a successful comparison on comparator A or B with the exception that the FLAG bit is not set.

NOTE

When in freeze state, the FORCMA or FORCMB bits only allow the software to force the output flip-flop to the level corresponding of a match on A or B respectively.

If subsequent matches occur on comparators A and B, the PWM pulses continue to be generated, regardless of the state of the FLAG bit.

In order to achieve a duty cycle of 100%, both registers A1 and B1 must be set to the same value. When a simultaneous match occurs between the selected time base and registers A1 and B1, the output flip-flop is set to the value of EDPOL bit and the selected time base switches to the selected counter bus, allowing a new cycle to begin at any time, as previously described. 0% duty cycle is possible by writing 0x00_0000 to register A (EMIOS_CADR). When a match occurs, the output flip-flop is set to the complement of EDPOL bit and the selected time base switches to the selected counter bus, allowing a new cycle to begin at any time, as previously described. In both cases, FLAG is generated regardless of the MODE[6] bit.

NOTE

If A1 and B1 are set to 0x00_0000, a 0% duty cycle waveform is produced.

Figure 23-45 and Figure 23-46 show the unified channel running in OPWMC with leading and trailing dead time, respectively.

MODE[0] = 1

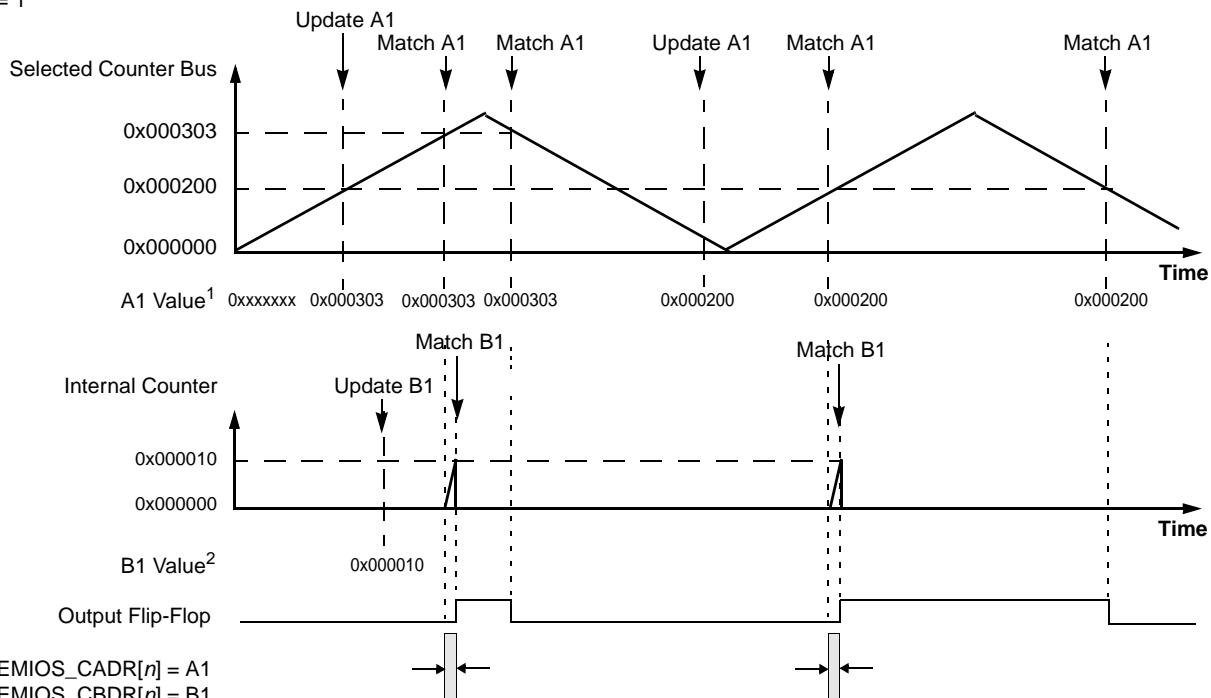

Notes: 1. EMIOS_CADR[n] = A1
 2. EMIOS_CBDR[n] = B1
 A2 = A1 according to OU[n] bit
 B2 = B1 according to OU[n] bit

Figure 23-45. OPWMC with Leading Dead Time Insertion

MODE[0] = 1

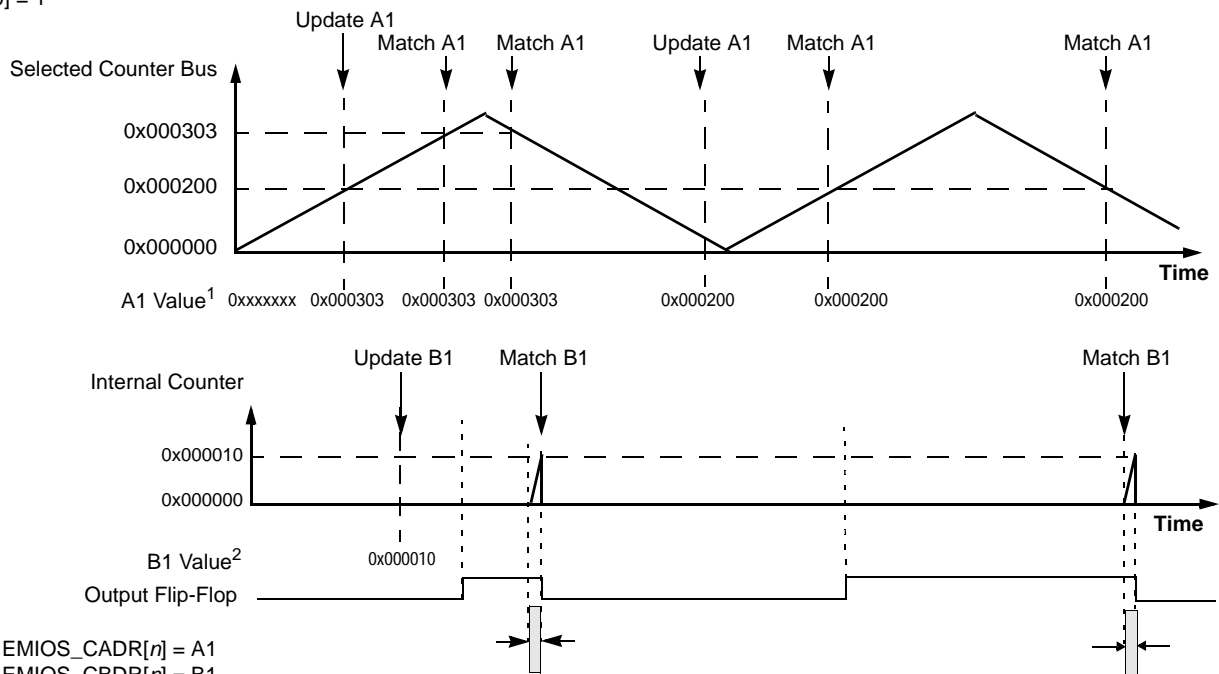

Notes: 1. EMIOS_CADR[n] = A1
 2. EMIOS_CBDR[n] = B1
 A2 = A1 according to OU[n] bit
 B2 = B1 according to OU[n] bit

Figure 23-46. OPWMC with Trailing Dead Time Insertion

23.4.1.1.16 Center-Aligned Output PWM Buffered with Dead Time (OPWMCB) Mode

The OPWMCB mode generates a center-aligned PWM with dead time insertion to the leading or trailing edge. A1 and B1 registers are double-buffered to allow smooth output signal generation when changing A2 or B2 registers values on the fly.

The BSL bits select the time base. The time base selected for a channel configured to OPWMCB mode should be a channel configured to MCB Up/Down mode, as shown in [Figure 23-35](#). It is recommended to start the MCB channel time base after the OPWMCB mode is entered in order to avoid missing A matches at the very first duty cycle.

Register A1 contains the ideal duty cycle for the PWM signal and is compared with the selected time base.

Register B1 contains the dead time value and is compared against the internal counter. For a leading edge dead time insertion, the output PWM duty cycle is equal to the difference between register A1 and register B1. For a trailing edge dead time insertion, the output PWM duty cycle is equal to the sum of register A1 and register B1. Mode[6] selects between trailing and leading dead time insertion.

NOTE

The internal counter runs in the internal prescaler ratio, while the selected time base may be running in a different prescaler ratio.

When OPWMCB mode is entered (coming out of GPIO mode), the output flip-flop is set to the complement of the EDPOL bit in the EMIOS_CCR[n] register.

The following basic steps summarize proper OPWMCB startup, assuming the channels are initially in GPIO mode:

1. [global] Disable Global Prescaler.
2. [MCB channel] Disable Channel Prescaler.
3. [MCB channel] Write \$1 at internal counter.
4. [MCB channel] Set A register.
5. [MCB channel] Set channel to MCB Up mode.
6. [MCB channel] Set prescaler ratio.
7. [MCB channel] Enable Channel Prescaler.
8. [OPWMCB channel] Disable Channel Prescaler.
9. [OPWMCB channel] Set A register.
10. [OPWMCB channel] Set B register.
11. [OPWMCB channel] Select time base input through BSL[1:0] bits.
12. [OPWMCB channel] Enter OPWMCB mode.
13. [OPWMCB channel] Set prescaler ratio.
14. [OPWMCB channel] Enable Channel Prescaler.
15. [global] Enable Global Prescaler.

[Figure 23-47](#) shows the load of A1 and B1 registers, which occurs when the selected counter bus transitions from 0x00_0002 to 0x00_0001. This event defines the cycle boundary. Values written to A2 or

B2 within cycle (n) are loaded into A1 or B1 registers, respectively, and used to generate matches in cycle ($n + 1$).

Prescaler Ratio = 2

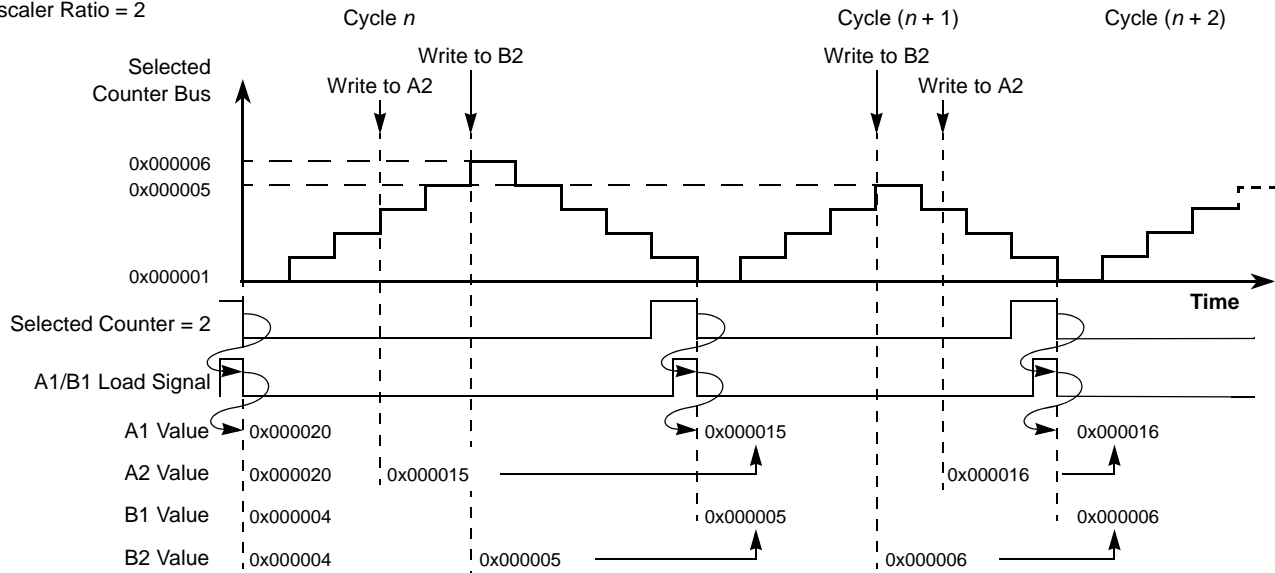

Figure 23-47. OPWMCB A1 and B1 Registers Load

The (OU[n] in EMIOS_OUDR) bit can be used to disable the A1 and B1 updates, thus allowing to synchronize the load on these registers with the load of A1 or B1 registers in others channels. Using the update disable bit, A1 and B1 registers can be updated at the same counter cycle, allowing both registers to change at the same time.

In this mode A1 matches always sets the internal counter to 0x00_0001. When operating with leading edge dead time insertion the first A1 match sets the internal counter to 0x00_0001. When a match occurs between register B1 and the internal time base, the output flip-flop is set to the value of the EDPOL bit. In the following match between register A1 and the selected time base, the output flip-flop is set to the complement of the EDPOL bit. This sequence repeats continuously. The internal counter should not reach 0x00_0000 as consequence of a rollover. To avoid this, the user must not write a value greater than twice the difference between external count up limit and EMIOS_CADR[n] value to the EMIOS_CBDR[n] register.

Figure 23-48 shows two cycles of a center-aligned PWM signal. Both A1 and B1 register values are changing within the same cycle, which allows to vary at the same time the duty cycle and dead time values.

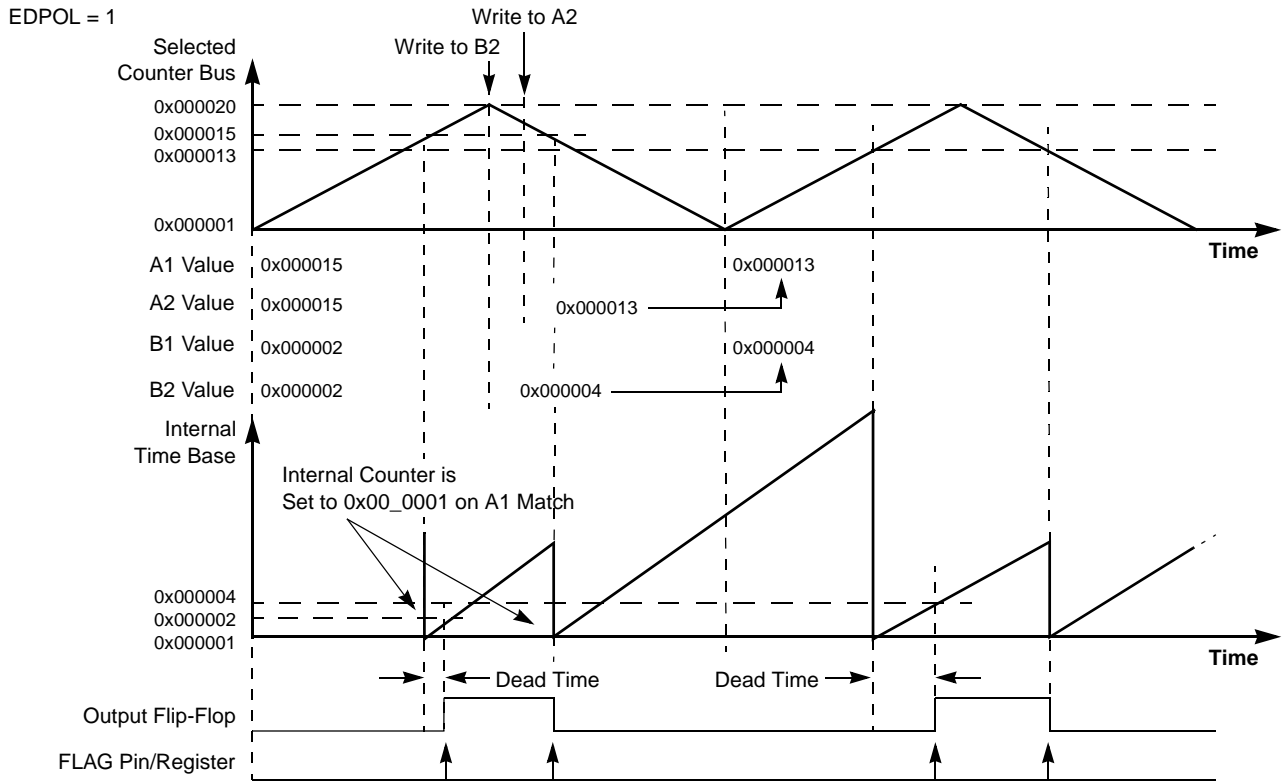

Figure 23-48. OPWMCB with Leading Dead Time Insertion

When operating with trailing edge dead time insertion, the first match between A1 and the selected time base sets the output flip-flop to the value of the EDPOL bit and sets the internal counter to 0x00_0001. In the second match between register A1 and the selected time base, the internal counter is set to 0x00_0001 and B1 matches are enabled. When the match between register B1 and the selected time base occurs, the output flip-flop is set to the complement of the EDPOL bit. This sequence repeats continuously.

EDPOL = 1

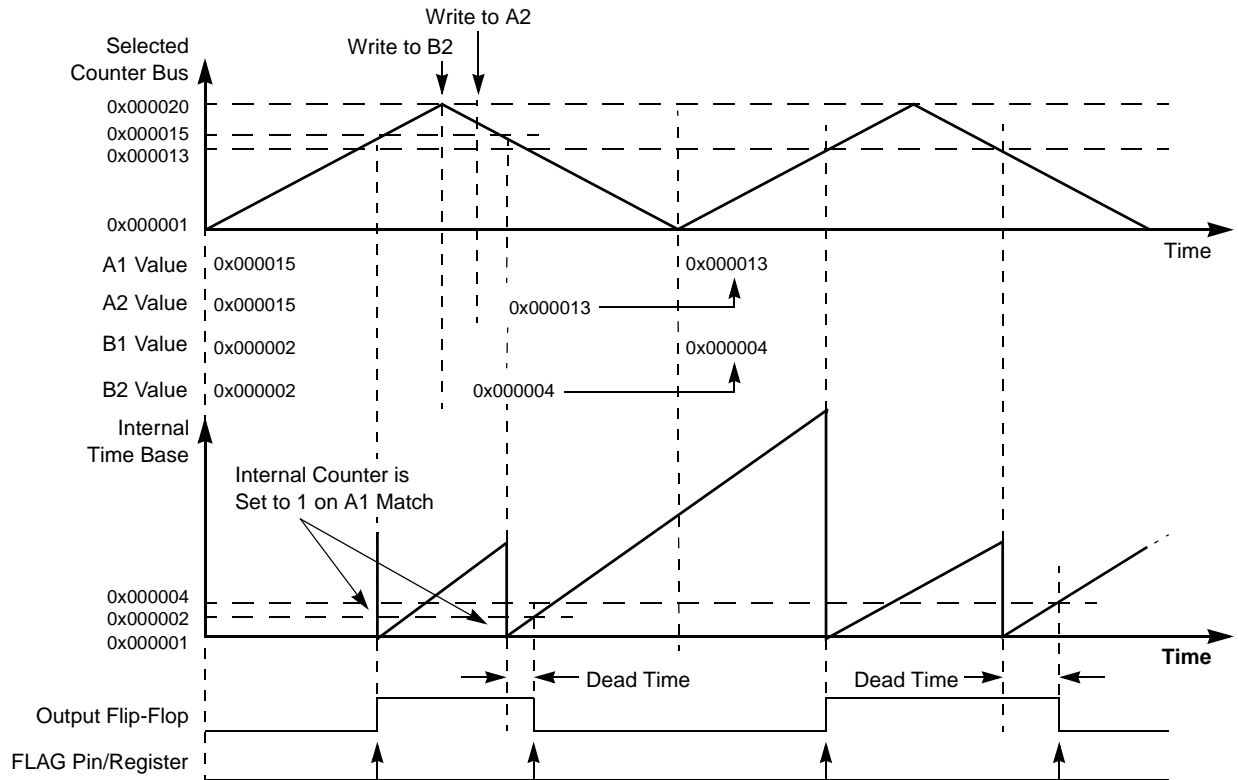

Figure 23-49. OPWMCB with Trailing Dead Time Insertion

FLAG can be generated in the trailing edge of the output PWM signal when MODE[5] is cleared, or in both edges when MODE[5] is set. If subsequent matches occur on comparators A and B, the PWM pulses continue to be generated regardless of the state of the FLAG bit.

NOTE

In OPWMCB mode, FORCMA and FORCMB do not have the same behavior as a regular match. Instead they force the output flip-flop to constant value, which depends on the selected dead time insertion mode, leading or trailing, and the value of the EDPOL bit.

FORCMA has different behaviors depending on the selected dead time insertion mode, leading or trail. In leading dead time insertion, FORCMA forces a transition in the output flip-flop to the opposite of the EDPOL bit. In trailing dead time insertion, the output flip-flop is forced to the value of the EDPOL bit.

If the FORCMB bit is set, the output flip-flop value depends on the selected dead time insertion mode. In leading dead time insertion, FORCMB forces the output flip-flop to transition to the EDPOL bit value. In trailing dead time insertion the output flip-flop is forced to the opposite of the EDPOL bit value.

NOTE

The FORCMA bit set does not set the internal time-base to 0x00_0001 as a regular A1 match.

The FLAG bit is not set either in case of FORCMA or FORCMB, even if both forces are issued at the same time.

NOTE

FORCMA and FORCMB have the same behavior even in freeze or normal mode regarding the output pin transition.

When FORCMA is issued along with FORCMB, the output flip-flop is set to the opposite of the EDPOL bit value. This is the equivalent of saying that FORCMA has precedence over FORCMB when leading dead time insertion is selected, and FORCMB has precedence over FORCMA when trailing dead time insertion is selected.

Duty cycles from 0% to 100% can be generated by setting appropriate values to the A1 and B1 registers relative to the period of the external time base. Setting $A1 = 0x00_0001$ generates a 100% duty cycle waveform. If A1 is greater than the maximum value of the selected counter bus period, then a 0% duty cycle is produced. Assuming EDPOL is set to 1 in OPWMCB mode with trailing dead time insertion, 100% duty cycle signals can be generated if B1 occurs at or after the cycle boundary (external counter = 1).

If A1 is greater than the maximum value of the selected counter bus period, then a 0% duty cycle is produced, only if the pin starts the current cycle in the opposite of the EDPOL value. In case of 100% duty cycle, the transition from EDPOL to the opposite of EDPOL may be obtained by forcing the pin using FORCMA and/or FORCMB.

NOTE

If A1 is set to $0x00_0001$ at OPWMCB entry the 100% duty cycle may not be obtained in the very first PWM cycle due to the pin condition at mode entry.

Only values different than 0x0 are allowed to be written to A1 register. If $0x00_0000$ is loaded to A1, the results are unpredictable.

NOTE

A special case occurs when A1 is set to $(\text{external counter bus period})/2$, which is the maximum value of the external counter. In this case, the output flip-flop is constantly set to the EDPOL bit value.

The internal channel logic prevents matches from one cycle to propagate to the next cycle. In trailing dead time insertion, a B1 match from cycle (n) could eventually cross the cycle boundary and occur in cycle ($n + 1$). In this case, the B1 match is masked out and does not cause the output flip-flop to transition. Therefore, matches in cycle ($n + 1$) are not affected by the late B1 matches from cycle (n).

Figure 23-50 shows a 100% duty cycle output signal generated by setting $A1 = 4$ and $B1 = 3$. In this case the trailing edge is positioned at the boundary of cycle $n + 1$, which is actually considered to belong to cycle $n + 2$ and therefore does not cause the output flip-flop to transition.

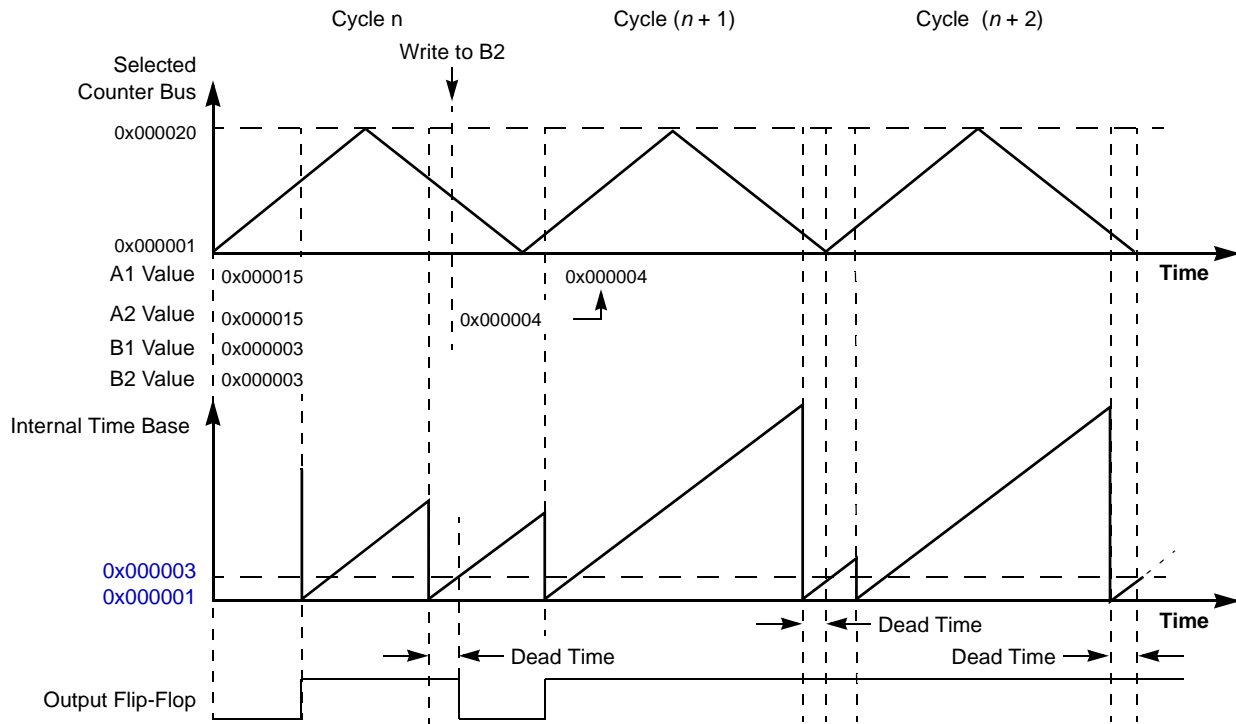

Figure 23-50. OPWMCB with 100% Duty Cycle (A1 = 4 and B1 = 3)

The output disable feature, if enabled, causes the output flip-flop to transition to the EDPOL inverted state. This feature allows an application to force the channel output pin to a “safe” state. The internal channel matches continue to occur even in this case, thus generating flags. As soon as the output disable is deasserted, the channel output pin is again controlled by the A1 and B1 matches. This process is synchronous, meaning that the output channel pin transitions on system clock edges only.

It is important to notice that, as in OPWMB and OPWFMB modes, the match signal used to set or clear the channel output flip-flop is generated on the deassertion of the channel combinational comparator output signal, which compares the selected time base with A1 or B1 register values. Refer to [Figure 23-40](#), which shows the delay from matches to output flip-flop transition in OPWFMB mode. The operation of OPWMCB mode is similar to OPWFMB regarding matches and output pin transition.

23.4.1.1.17 Output Pulse Width Modulation (OPWM) Mode

In OPWM mode, registers A1 and B1 define the leading and trailing edges of the PWM output pulse, respectively. The MODE[6] bit controls the transfer from register B2 to B1, which can be done either immediately (MODE[6] cleared, MODE = 010_00b0), providing the fastest change in the duty cycle, or at every match of register A1 (MODE[6] set, MODE = 010_00b1).

The value loaded in register A1 is compared with the value on the selected time base. When a match on comparator A occurs, the output flip-flop is set to the value of the EDPOL bit. When a match occurs on comparator B, the output flip-flop is set to the complement of the EDPOL bit.

FLAG can be generated at match B, when MODE[5] is cleared, or in both matches, when MODE[5] is set.

At any time, the FORCMA and FORCMB bits allow the software to force the output flip-flop to the level corresponding to a match on A or B respectively. Note that FLAG bit is not set by the FORCMA and FORCMB operations.

If subsequent matches occur on comparators A and B, the PWM pulses continue to be generated, regardless of the state of the FLAG bit.

At OPWM mode entry, the output flip-flop is set to the complement of the EDPOL bit in the EMIOS_CCR[n] register.

In order to achieve 100% duty cycle, both registers A1 and B1 must be set to the same value. When a simultaneous match on comparators A and B occur, the output flip-flop is set at every period to the value of EDPOL bit. 0% duty cycle is possible by writing 0x0 to register A (EMIOS_CADR). When a match occurs, the output flip-flop is set at every period to the complement of EDPOL bit. The transfer from register B2 to B1 is still controlled by MODE[6] bit.

NOTE

If A1 and B1 are set to 0x00_0000, a 0% duty cycle waveform is produced.

Figure 23-51 and Figure 23-52 show the unified channel running in OPWM with immediate update and next period update, respectively.

MODE[6] = 0

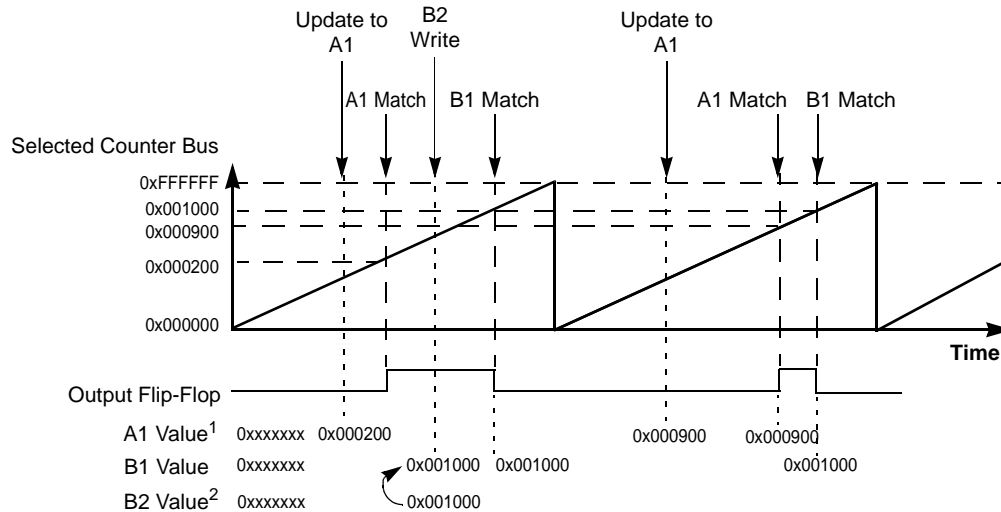

- Notes: 1. EMIOS_CADR[n] = A1
- 2. EMIOS_CBDR[n] = B2
- A2 = A1 according to OU[n] bit
- B2 = B1 according to OU[n] bit

Figure 23-51. OPWM with Immediate Update

MODE[6] = 1

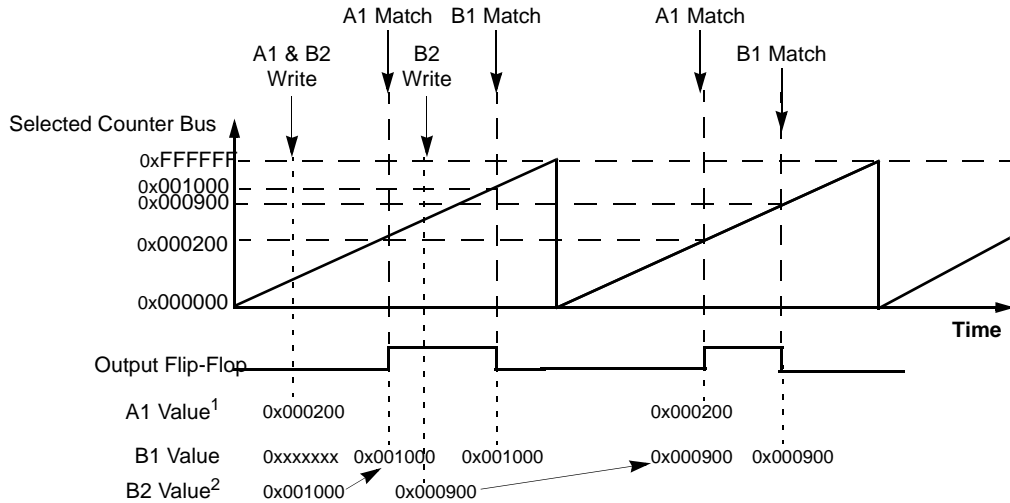

Notes: 1. EMIOS_CADR[n] = A1
 2. EMIOS_CBDR[n] = B2
 A2 = A1 and A2 = A1 according to OU[n] bit

Figure 23-52. OPWM with Next Period Update

23.4.1.1.18 Output Pulse-Width Modulation Buffered (OPWMB) Mode

OPWMB mode (MODE = 110_00b0) is used to generate pulses with programmable leading- and trailing-edge placement. An external counter must be selected from one of the counter buses. The A1 register value defines the first edge and B1 defines the second edge. The output signal polarity is defined by the EDPOL bit. If EDPOL is 0, a negative edge occurs when A1 matches the selected counter bus; and a positive edge occurs when B1 matches the selected counter bus.

The A1 and B1 registers are double buffered and updated from A2 and B2, respectively, at the cycle boundary. The load operation is similar to the OPWFMB mode. Please refer to Figure 23-42 for more information about A1 and B1 registers update.

FLAG can be generated at B1 matches, when MODE[5] is cleared, or in both A1 and B1 matches, when MODE[5] is set. If subsequent matches occur on comparators A and B, the PWM pulses continue to be generated, regardless of the state of the FLAG bit.

FORCMA and FORCMB bits allow the software to force the output flip-flop to the level corresponding to a match on A1 or B1 respectively. The FLAG bit is not set by the FORCMA and FORCMB operations.

At OPWMB mode entry the output flip-flop is set to the value of the EDPOL bit in the EMIOS_CCR[n] register.

Some rules applicable to the OPWMB mode include:

- B1 matches have precedence over A1 matches if they occur at the same time within the same counter cycle
- A1 = 0 match from cycle(n) has precedence over B1 match from cycle(n - 1)
- A1 matches are masked out if they occur after B1 match within the same cycle

- Any value written to A2 or B2 on cycle(n) is loaded to A1 and B1 registers at the following cycle boundary (assuming $OU[n]$ in $EMIOS_OUDR$) is not asserted). The new values are used for A1 and B1 matches in cycle($n + 1$)

Figure 23-53 shows the operation of the OPWMB mode regarding A1 and B1 matches and the transition of the channel output pin. In this example, $EDPOL$ is set to 0.

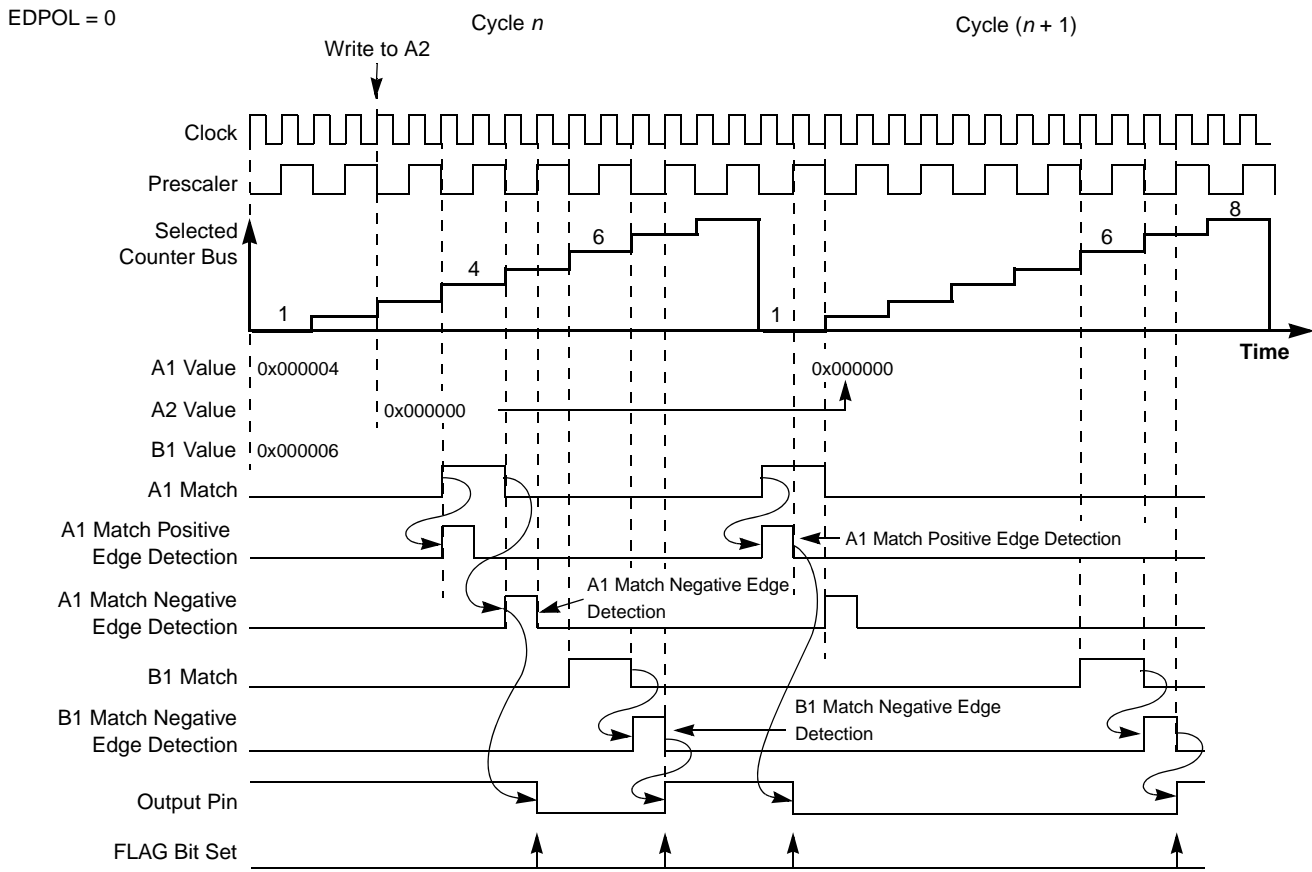

Figure 23-53. OPWMB Mode Matches and Flags

The output pin transitions are based on the negative edges of the A1 and B1 match signals. Figure 23-53 shows in cycle($n + 1$) the value of the A1 register being set to 0. In this case, the match positive edge is used instead of the negative edge to transition the output flip-flop.

Figure 23-54 shows the channel operation for 0% duty cycle. Note that the A1 match positive edge signal occurs at the same time as the B1 = 0x00_0008 negative edge signal. In this case A1 match has precedence over B1 match, causing the output pin to remain at $EDPOL$ bit value, thus generating a 0% duty cycle signal.

EDPOL = 0

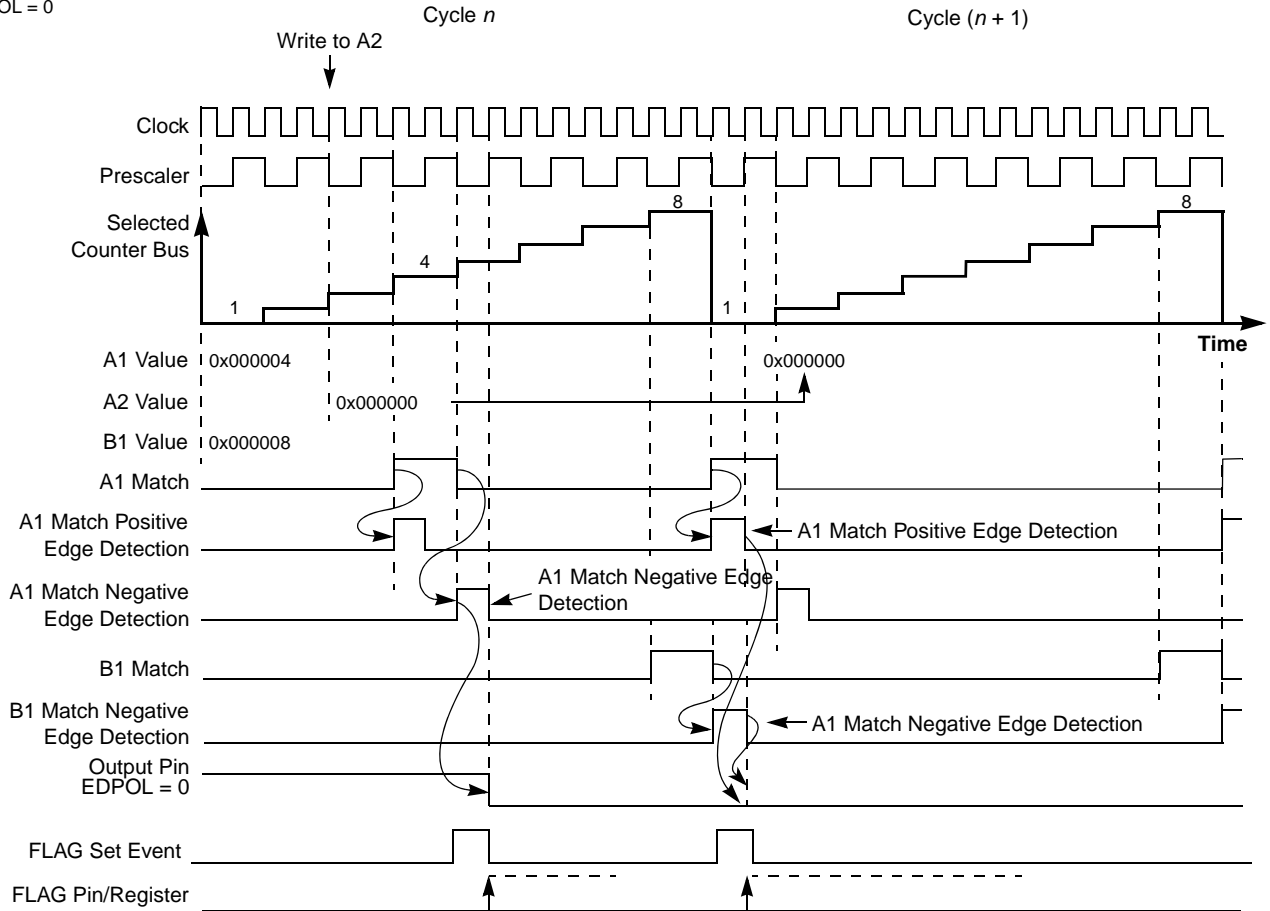

Figure 23-54. OPWMB Mode with 0% Duty Cycle

Figure 23-55 shows the operation of the OPWMB mode with the output disable signal asserted. The output disable forces a transition in the output pin to the EDPOL bit value. After deassertion, the output disable allows the output pin to transition at the following A1 or B1 match. The output disable does not modify the flag bit behavior. There is a delay of one system clock between the assertion of the output disable signal and the transition of the output pin to EDPOL.

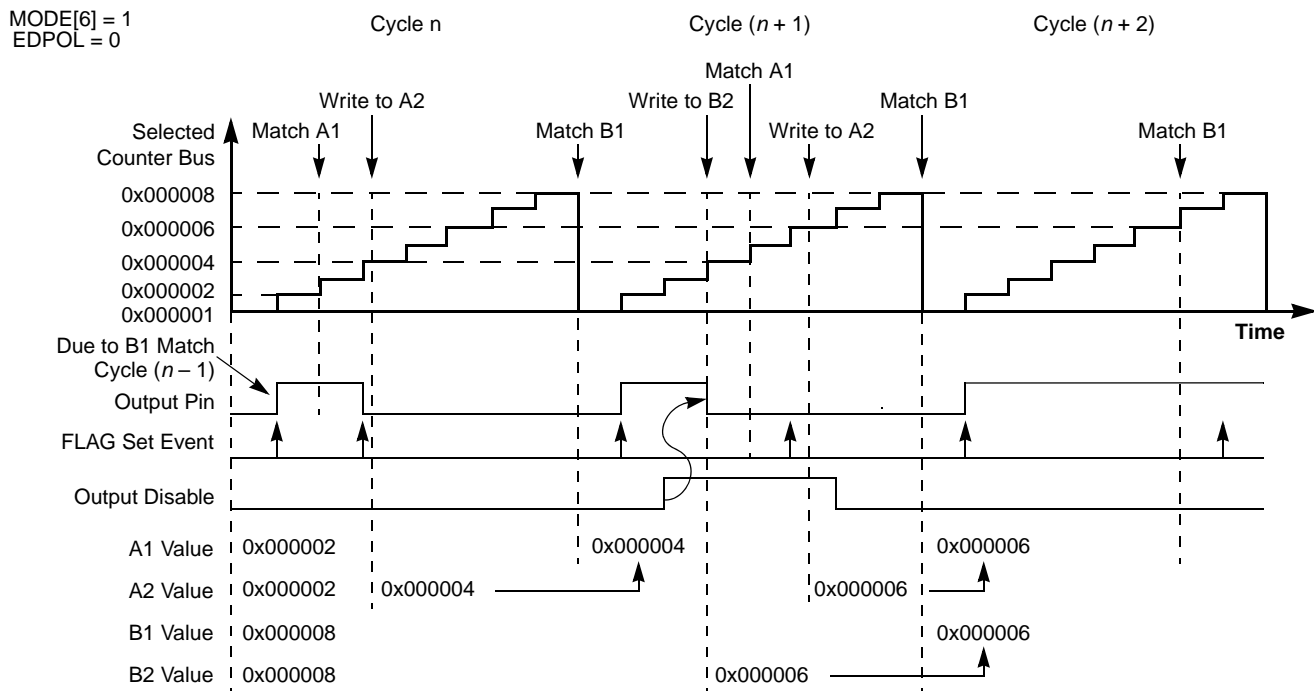

Figure 23-55. OPWMB Mode with Active Output Disable

Figure 23-56 shows a waveform changing from 100% to 0% duty cycle. In this case, EDPOL is 0. In this example, B1 is programmed to the same value as the period of the external selected time base.

EDPOL = 0
Prescaler = 1

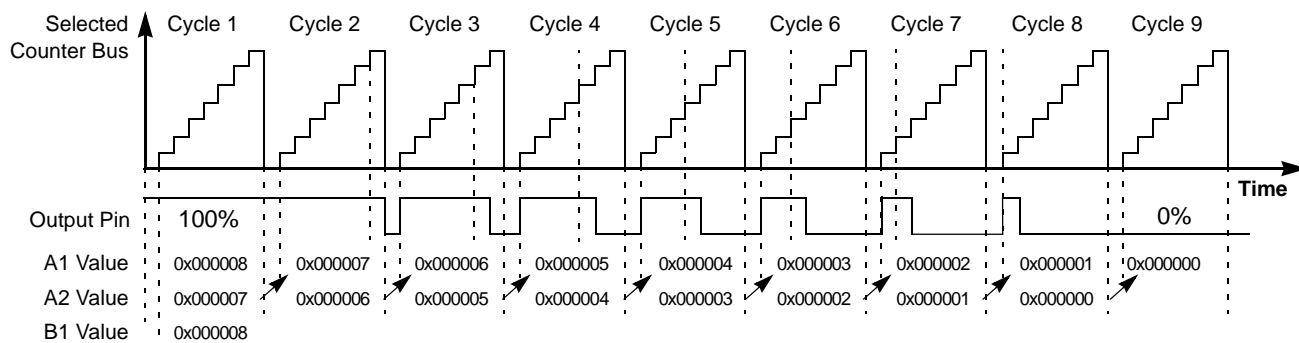

Figure 23-56. OPWMB Mode from 100% to 0% Duty Cycle

In Figure 23-56, if B1 is set to a value lower than 0x00_0008, it is not possible to achieve 0% duty cycle by changing only the A1 register value. Because B1 matches have precedence over A1 matches, the output pin transitions to the opposite of EDPOL bit at B1 match. If B1 is set to 0x00_0009, for instance, B1 match does not occur, thus a 0% duty cycle signal is generated.

23.4.1.2 Input Programmable Filter (IPF)

The IPF is a 5-bit programmable up counter that is incremented by the selected clock source, according to IF bits in EMIOS_CCR[n]. The IPF ensures that only valid input pin transitions are received by the unified channel edge detector. [Figure 23-57](#) shows a block diagram of the IPF.

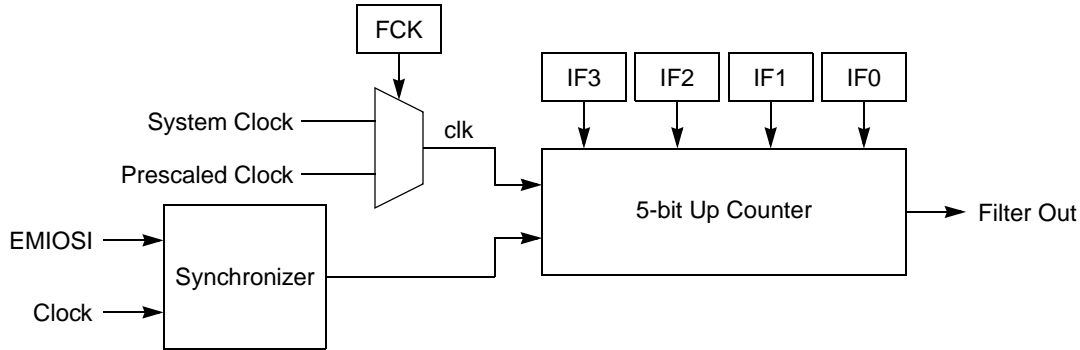

Figure 23-57. Input Programmable Filter Submodule Diagram

The input signal is synchronized by system clock. When a state change occurs in this signal, the 5-bit counter starts counting up. As long as the new state is stable on the pin, the counter remains incrementing. If a counter overflow occurs, the new pin value is validated. In this case, it is transmitted as a pulse edge to the edge detector. If the opposite edge appears on the pin before validation (overflow), the counter is reset. At the next pin transition, the counter starts counting again. Any pulse that is shorter than a full range of the masked counter is regarded as a glitch and it is not passed on to the edge detector. [Figure 23-58](#) shows a timing diagram of the input filter.

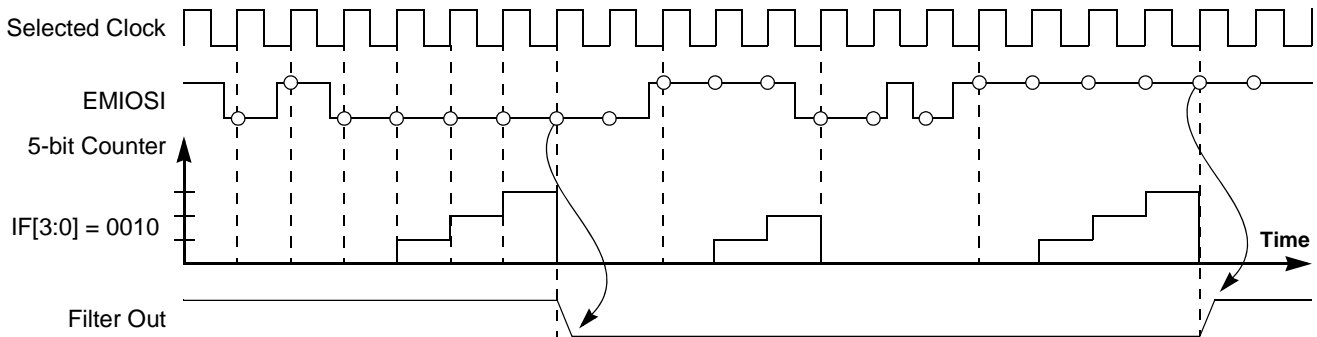

Figure 23-58. Input Programmable Filter Example

The filter is not disabled during either freeze state or negated GTBE input.

23.4.1.3 Clock Prescaler (CP)

The CP divides the GCP output signal to generate a clock enable for the internal counter of the unified channels. It is a programmable 2-bit down counter. The GCP output signal is prescaled by the value defined in the UCPRE bits in the EMIOS_CCR[n] register. The output is clocked every time the counter reaches zero. Counting is enabled by setting the UCPREN bit in the EMIOS_CCR[n]. The counter can be stopped at any time by clearing this bit, thereby stopping the internal counter in the unified channel.

In order to ensure safe working and avoid glitches the following steps must be performed whenever any update in the prescaling rate is desired:

1. Write 0 at both GPREN bit in EMIOSMCR register and UCPREN bit in EMIOS_CCR[n] register, thus disabling prescalers;
2. Write the desired value for prescaling rate at UCPRE[] bits in EMIOS_CCR[n] register;
3. Enable channel prescaler by writing 1 at UCPREN bit in EMIOS_CCR[n] register;
4. Enable global prescaler by writing 1 at GPREN bit in EMIOSMCR register.

The prescaler is not disabled during either freeze state or negated GTBE input.

23.4.1.4 Effect of Freeze on the Unified Channel

When in debug mode, if the FRZ bit in the EMIOS_MCR register and the FREN bit in the EMIOS_CCR[n] are both set, the internal counter and unified channel capture and compare functions are halted. The unified channel is frozen in its current state.

During freeze, all registers are accessible. When the unified channel is operating in an output mode, the force match functions remain available, allowing the software to force the output to the desired level.

During input modes, any input events that may occur while the channel is frozen are ignored.

When exiting debug mode or when the freeze enable bit is cleared (FRZ in the EMIOS_MCR or FREN in the EMIOS_CCR[n] register), the channel actions resume but may be inconsistent until the channel enters GPIO mode again.

23.4.2 IP Bus Interface Unit (BIU)

The BIU provides the interface between the internal interface bus (IIB) and the peripheral bus, allowing communication among all submodules and this IP interface.

The BIU allows 8-, 16-, and 32-bit access. They are performed over a 32-bit data bus in a single cycle clock.

23.4.2.1 Effect of Freeze on the BIU

When the FRZ bit in the EMIOS_MCR register is set and the module is in debug mode, the operation of BIU is not affected.

23.4.3 STAC Client Submodule

The shared time and angle count (STAC) bus provides access to one external time base, imported from the STAC bus to the eMIOS unified channels. The eTPU module's time bases and angle count can be exported and/or imported through the STAC client submodule interface. Time bases and/or angle information of either eTPU engine can be exported to the other eTPU engine and to the eMIOS module, which is only a STAC client. There are restrictions on engine export/import targets: one engine cannot export from or import to itself, nor can it import time base and/or angle count if in angle mode.

The device's STAC server identification assignment is shown in Table 23-11. The time slot assignment is fixed, so only time bases running at system clock divided by four or slower can be integrally exported. The STAC client submodule runs with the system clock, and its time slot timing is synchronized with the eTPU timing on reset. The time slot sequence is 0-1-2-3, such that they alternate between engines one and two.

Table 23-11. STAC Client Submodule Server Slot Assignment

| Engine | Time Base | Server ID |
|--------|-----------|-----------|
| 1 | TCR1 | 0 |
| 1 | TCR2 | 2 |
| 2 | TCR1 | 1 |
| 2 | TCR2 | 3 |

Figure 23-59 provides a block diagram for the STAC client submodule.

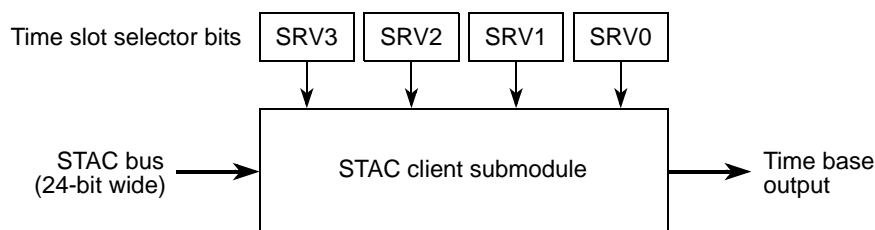
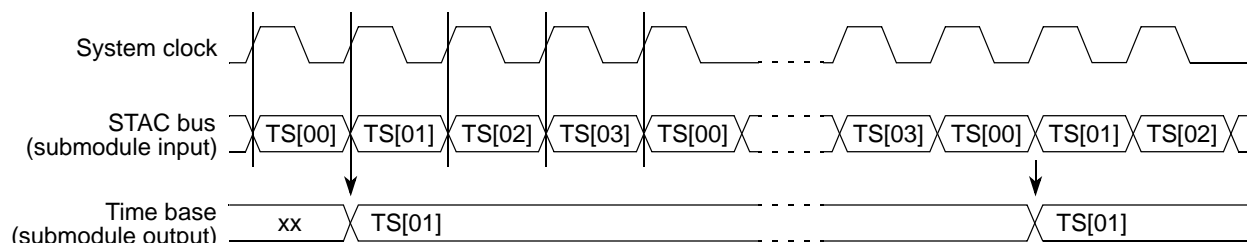
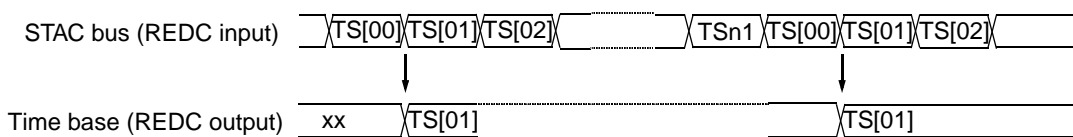

Figure 23-59. STAC Client Submodule Block Diagram

EMIOS_MCR[SRV] bits select the time slot of the STAC output bus. Figure 23-60 shows a timing diagram for the STAC client submodule.



The SRV bits are set to capture TS[01].



- NOTES:
1. Maximum of 16 time slots (TS_n)
 2. The SRV bits capture TS[01]

Figure 23-60. Timing Diagram for the STAC Bus and STAC Client Submodule Output

Every time the selected time slot changes, the STAC client submodule output is updated.

23.4.3.1 Effect of Freeze on the STAC Client Submodule

When the FRZ bit in the EMIOS_MCR is set and the module is in debug mode, the operation of the STAC client submodule is not affected; that is, there is no freeze function in this submodule.

23.4.4 Global Clock Prescaler Submodule (GCP)

The GCP divides the system clock to generate a clock for the clock prescalers (CP) of the unified channels. It is a programmable 8-bit up counter. The main clock signal is prescaled by the value defined in the GPRE bits in EMIOS_MCR. The output is clocked every time the counter overflows. Counting is enabled by setting the GPREN bit in the EMIOS_MCR. The counter can be stopped at any time by clearing this bit, thereby stopping the internal counter in all the unified channels.

In order to ensure safe working and avoid glitches the following steps must be performed whenever any update in the prescaling rate is desired:

1. Write 0 at GPREN bit in EMIOSMCR register, thus disabling global prescaler;
2. Write the desired value for prescaling rate at GPRE[0:7] bits in EMIOSMCR register;
3. Enable global prescaler by writing 1 at GPREN bit in EMIOSMCR register.

The prescaler is not disabled during either freeze state or negated GTBE input.

23.4.4.1 Effect of Freeze on the GCP

When the FRZ bit in the EMIOS_MCR register is set and the module is in debug mode, the operation of GCP submodule is not affected, i.e., there is no freeze function in this submodule.

23.5 Reset

The eMIOS200 is reset by the global asynchronous system reset signal.

The MDIS bit in the EMIOS_MCR register is cleared during reset.

On resetting the eMIOS200 all unified channels enter GPIO input mode.

23.6 Interrupts

The eMIOS200 can generate one interrupt per channel. An interrupt request is generated according to the configuration of the channel and input events or matches. See [Chapter 10, Interrupts and Interrupt Controller \(INTC\)](#), for details on the eMIOS200 interrupt vectors.

23.7 Initialization/Application Information

On resetting the eMIOS200 all unified channels enter GPIO input mode.

23.7.1 Considerations

Before changing an operating mode, the unified channel must be programmed to GPIO mode and EMIOS_CADR[*n*] and EMIOS_CBDR[*n*] registers must be updated with the correct values for the next operating mode. Then the EMIOS_CCR[*n*] register can be written with the new operating mode. If a unified channel is changed from one mode to another without performing this procedure, the first operation cycle of the selected time base can be random, i.e., matches can occur in random time if the contents of EMIOS_CADR[*n*] or EMIOS_CBDR[*n*] were not updated with the correct value before the time base matches the previous contents of EMIOS_CADR[*n*] or EMIOS_CBDR[*n*].

When interrupts are enabled, the software must clear the FLAG bits before exiting the interrupt service routine.

23.7.2 Application Information

Correlated output signals can be generated by all output operation modes. The OU[*n*] bits in EMIOS_OUDR can be used to control the update of these output signals.

In order to guarantee the internal counters of correlated channels are incremented in the same clock cycle, the internal prescalers must be set before enabling the global prescaler. If the internal prescalers are set after enabling the global prescaler, the internal counters may increment in the same ratio but at a different clock cycle.

23.7.3 Time Base Generation

For MC, OPWFM, and OPWM with internal clock source operation modes, the internal counter rate can be modified by configuring the clock prescaler ratio. [Figure 23-61](#) shows an example of a time base with prescaler ratio equal to one. When the prescaler is greater than one, the counter is immediately cleared on a match and then incremented in the next prescaled clock edge, except when running in OPWFM mode or MC mode with internal clock source. In these cases, the counter will skip the next prescaled clock edge and continue incremented on subsequent edges, as shown in [Figure 23-62](#).

NOTE

MCB, OPWFMB, and OPWMB modes have a different behavior.

PRESCALED CLOCK RATIO = 1 (Bypassed)

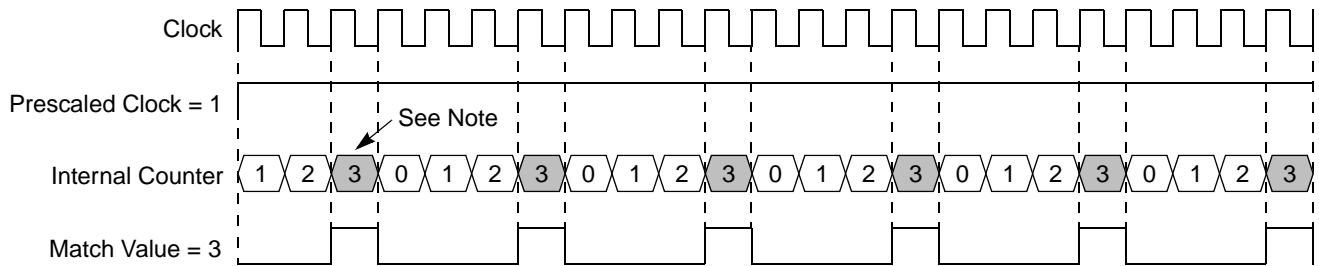

Note: When a match occurs, the first clock cycle is used to clear the internal counter, starting another period.

Figure 23-61. Time Base Period when Running in the Fastest Prescaler Ratio

If the prescaler ratio is greater than one or external clock is selected, the counter may behave in three different ways depending on the channel mode:

- If MC mode and Clear on Match Start and External Clock source are selected the internal counter behaves as described in [Figure 23-63](#).
- If MC mode and Clear on Match Start and Internal Clock source are selected the internal counter behaves as described in [Figure 23-64](#).
- If MC mode and Clear on Match End are selected the internal counter behaves as described in [Figure 23-65](#).
- If OPWFM mode is selected the internal counter behaves as described in [Figure 23-64](#). The internal counter clears at the start of the match signal, skips the next prescaled clock edge and then increments in the subsequent prescaled clock edge.

NOTE

MCB and OPWFMB modes have a different behavior.

PRESCALED CLOCK RATIO = 3

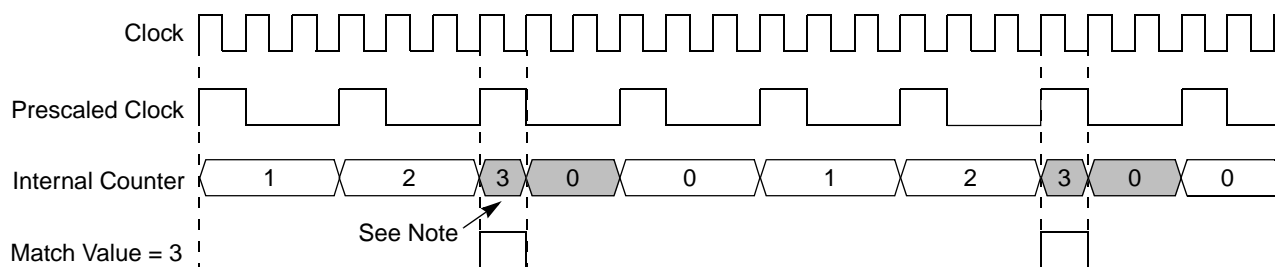

Note: When a match occurs, the first clock cycle is used to clear the internal counter, and only after a second edge of prescaled clock the counter will start counting.

Figure 23-62. Time Base Period when Running with a Prescaler Ratio Greater Than 1

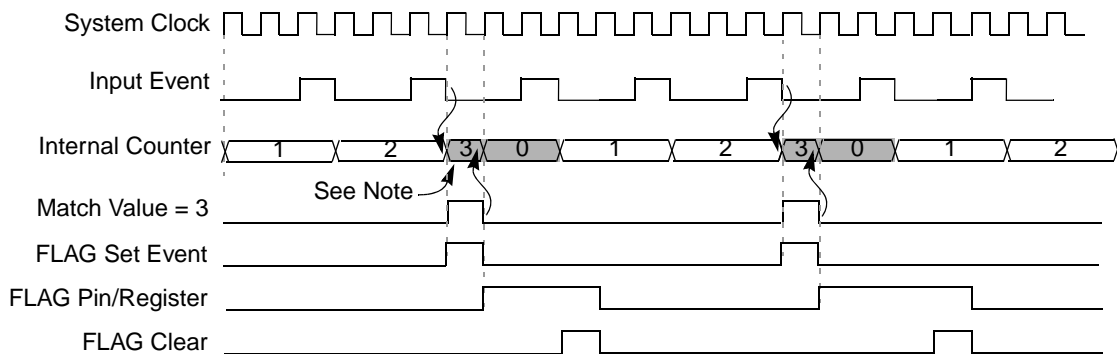

Note: When a match occurs, the first system clock cycle is used to clear the internal counter, and at the next edge of prescaler clock enable the counter will start counting.

Figure 23-63. Time Base Generation with External Clock and Clear on Match Start

PRESCALED CLOCK RATIO = 3

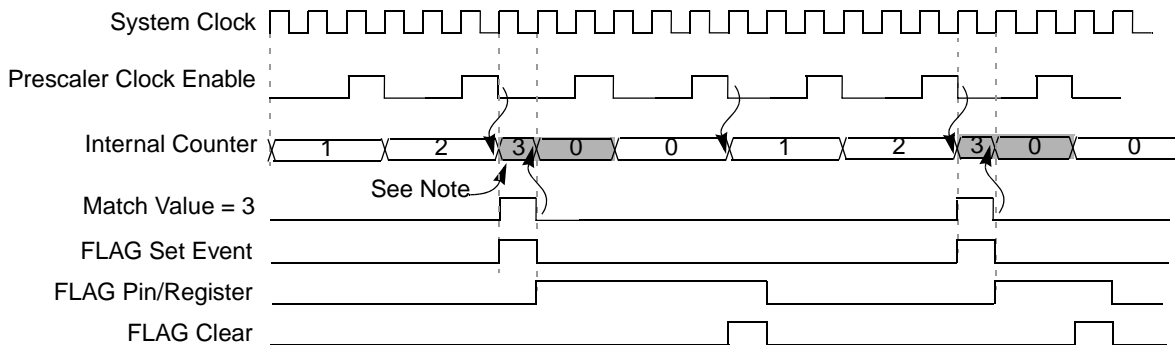

Note: When a match occurs, the first clock cycle is used to clear the internal counter, and only after a second edge of prescaled clock the counter will start counting.

Figure 23-64. Time Base Generation with Internal Clock and Clear on Match Start

PRESCALED CLOCK RATIO = 3

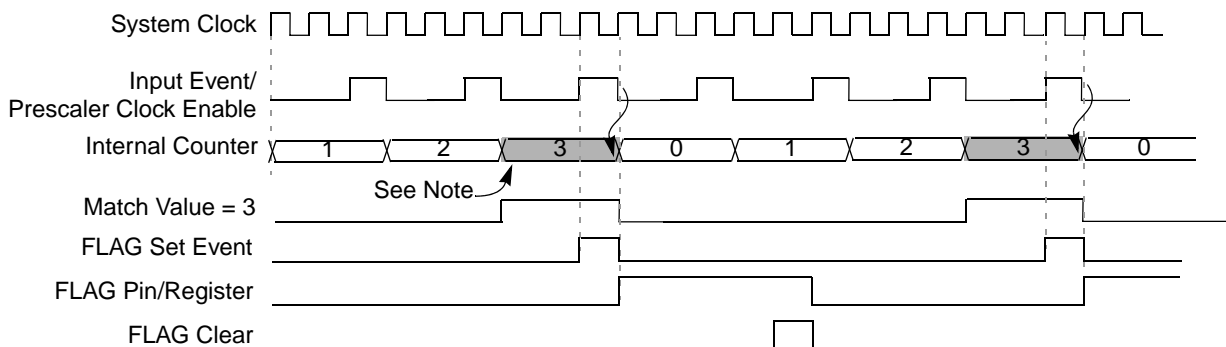

Note: The match occurs only when the input event/prescaler clock enable is active. Then, the internal counter is immediately cleared.

Figure 23-65. Time Base Generation with Clear on Match End

23.7.4 Coherent Accesses

For IPWM and IPM modes, it is recommended that the software wait for a new FLAG set event before reading EMIOS_CADR[*n*] and EMIOS_CBDR[*n*] registers to get a new measurement. The FLAG indicates that new data has been captured and it is the only way to assure data coherency.

The FLAG set event can be detected by polling the FLAG bit or by enabling the interrupt or DMA request generation.

Reading the EMIOS_CADR[*n*] register again in the same period of the last read of EMIOS_CBDR[*n*] register may lead to incoherent results. This occurs if the last read of EMIOS_CBDR[*n*] register occurred after a disabled B2 to B1 transfer.



Chapter 24

FlexCAN Module

24.1 Introduction

This device has four FlexCAN modules: A, B, C, and D. The remainder of this chapter describes one module.

Each FlexCAN module is a communication controller implementing the CAN protocol according to the CAN 2.0B protocol specification [Ref. 1]. A general block diagram is shown in [Figure 24-1](#), which describes the main sub-blocks implemented in the FlexCAN module, including two embedded memories, one for storing Message Buffers (MB) and another one for storing Rx Individual Mask Registers. Support for 64 Message Buffers is provided. The functions of the sub-modules are described in subsequent sections.

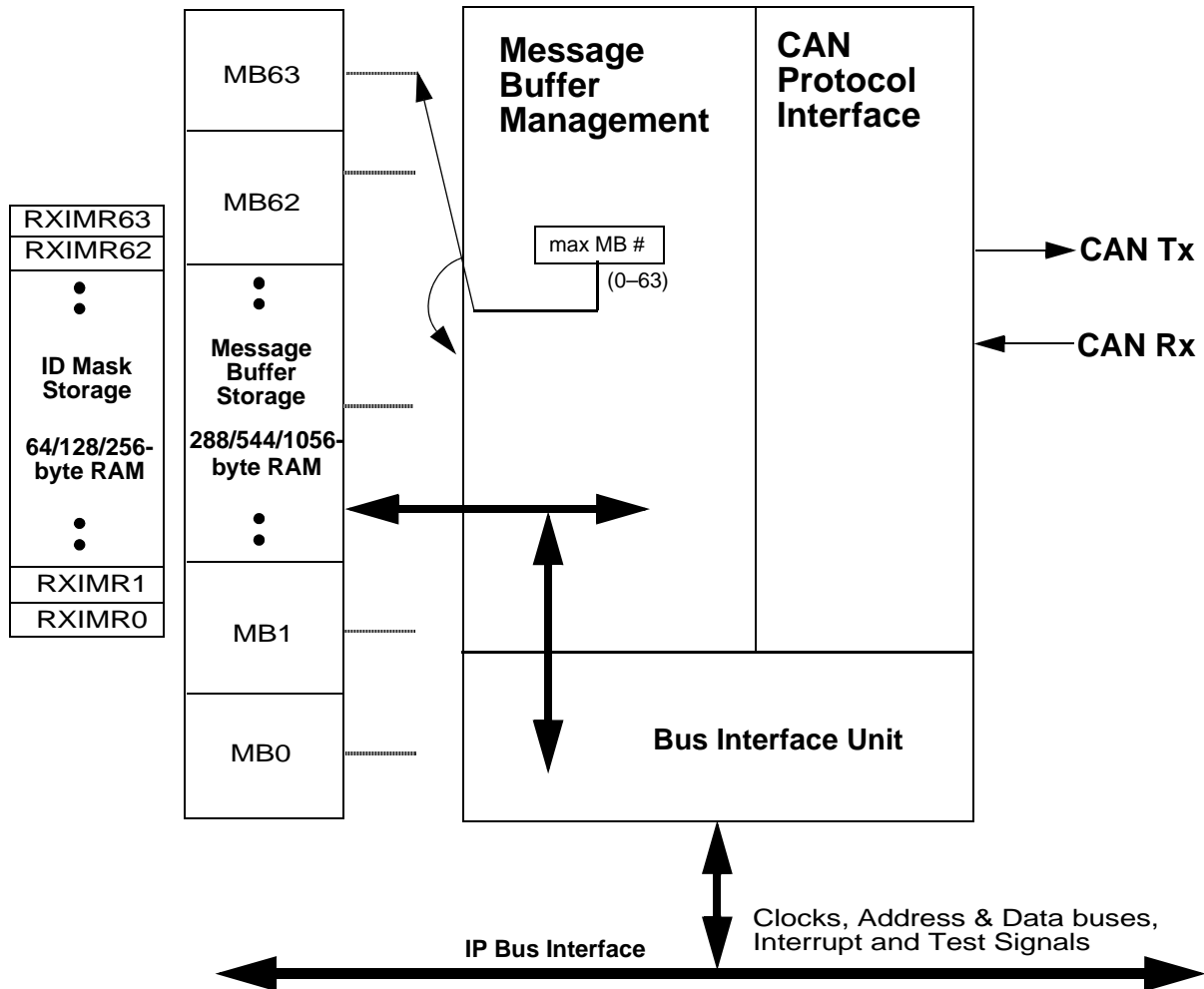

Figure 24-1. FlexCAN Block Diagram

24.1.1 Overview

The CAN protocol was primarily, but not only, designed to be used as a vehicle serial data bus, meeting the specific requirements of this field: real-time processing, reliable operation in the EMI environment of a vehicle, cost-effectiveness and required bandwidth. The FlexCAN module is a full implementation of the CAN protocol specification, Version 2.0 B [Ref. 1], which supports both standard and extended message frames. A flexible number of Message Buffers (16, 32 or 64) is also supported. The Message Buffers are stored in an embedded RAM dedicated to the FlexCAN module. Please refer to the Device User Guide for the actual number of Message Buffer configured in the MCU

The CAN Protocol Interface (CPI) sub-module manages the serial communication on the CAN bus, requesting RAM access for receiving and transmitting message frames, validating received messages and performing error handling. The Message Buffer Management (MBM) sub-module handles Message Buffer selection for reception and transmission, taking care of arbitration and ID matching algorithms. The Bus Interface Unit (BIU) sub-module controls the access to and from the internal interface bus, in order to establish connection to the CPU and to other blocks. Clocks, address and data buses, interrupt outputs and test signals are accessed through the Bus Interface Unit.

24.1.2 FlexCAN Module Features

The FlexCAN module includes these distinctive features:

- Full Implementation of the CAN protocol specification, Version 2.0B
 - Standard data and remote frames
 - Extended data and remote frames
 - Zero to eight bytes data length
 - Programmable bit rate up to 1 Mb/sec
 - Content-related addressing
- Flexible Message Buffers (64) of zero to eight bytes data length
- Each MB configurable as Rx or Tx, all supporting standard and extended messages
- Individual Rx Mask Registers per Message Buffer
- Includes 1056 bytes (64 MBs) of RAM used for MB storage
- Includes 256 bytes (64 MBs) of RAM used for individual Rx Mask Registers
- Full featured Rx FIFO with storage capacity for 6 frames and internal pointer handling
- Powerful Rx FIFO ID filtering, capable of matching incoming IDs against either 8 extended, 16 standard or 32 partial (8 bits) IDs, with individual masking capability
- Selectable backwards compatibility with previous FlexCAN version
- Programmable clock source to the CAN Protocol Interface, either bus clock or crystal oscillator
- Unused MB and Rx Mask Register space can be used as general purpose RAM space
- Listen only mode capability
- Programmable loop-back mode supporting self-test operation
- Programmable transmission priority scheme: lowest ID, lowest buffer number or highest priority
- Time Stamp based on 16-bit free-running timer
- Global network time, synchronized by a specific message
- Maskable interrupts
- Independent of the transmission medium (an external transceiver is assumed)
- Short latency time due to an arbitration scheme for high-priority messages

- Low power modes

24.1.3 Modes of Operation

The FlexCAN module has these functional modes: Normal Mode (User and Supervisor), Freeze Mode, Listen-Only Mode and Loop-Back Mode. There are also these low power modes: Disable Mode and Stop Mode.

- Normal Mode (User or Supervisor):

In Normal Mode, the module operates receiving and/or transmitting message frames, errors are handled normally and all the CAN Protocol functions are enabled. User and Supervisor Modes differ in the access to some restricted control registers.
- Freeze Mode:

It is enabled when the FRZ bit in the FLEXCAN_x_MCR Register is asserted. If enabled, Freeze Mode is entered when the HALT bit in FLEXCAN_x_MCR is set or when Debug Mode is requested at MCU level. In this mode, no transmission or reception of frames is done and synchronicity to the CAN bus is lost. See [Section 24.4.9.1, Freeze Mode](#), for more information.
- Listen-Only Mode:

The module enters this mode when the LOM bit in the Control Register is asserted. In this mode, transmission is disabled, all error counters are frozen and the module operates in a CAN Error Passive mode [Ref. 1]. Only messages acknowledged by another CAN station will be received. If FlexCAN detects a message that has not been acknowledged, it will flag a BIT0 error (without changing the REC), as if it was trying to acknowledge the message.
- Loop-Back Mode:

The module enters this mode when the LPB bit in the Control Register is asserted. In this mode, FlexCAN performs an internal loop back that can be used for self test operation. The bit stream output of the transmitter is internally fed back to the receiver input. The Rx CAN input pin is ignored and the Tx CAN output goes to the recessive state (logic '1'). FlexCAN behaves as it normally does when transmitting and treats its own transmitted message as a message received from a remote node. In this mode, FlexCAN ignores the bit sent during the ACK slot in the CAN frame acknowledge field to ensure proper reception of its own message. Both transmit and receive interrupts are generated.
- Module Disable Mode:

This low power mode is entered when the MDIS bit in the FLEXCAN_x_MCR Register is asserted by the CPU. When the FlexCAN module is disabled, the module sends a request to disable the clocks to the CAN Protocol Interface and Message Buffer Management sub-modules. Exit from this mode is done by negating the MDIS bit in the FLEXCAN_x_MCR Register. See [Section 24.4.9.2, Module Disable Mode](#), for more information.
- Stop Mode:

This low power mode is entered when Stop Mode is requested at MCU level. When in Stop Mode, the module puts itself in an inactive state and then informs the CPU that the clocks can be shut down globally. Exit from this mode happens when the Stop Mode request is removed.

24.2 External Signal Description

24.2.1 Overview

The FlexCAN module has two I/O signals connected to the external MCU pins. These signals are summarized in [Table 24-1](#) and described in more detail in the next subsections.

Table 24-1. FlexCAN Signals

| Signal Name ¹ | Direction | Description |
|--------------------------|-----------|------------------|
| CAN Rx | Input | CAN Receive Pin |
| CAN Tx | Output | CAN Transmit Pin |

NOTES:

¹ The actual MCU pins may have different names. Please consult the Device User Guide for the actual signal names.

24.2.2 Signal Descriptions

24.2.2.1 CAN Rx

This pin is the receive pin from the CAN bus transceiver. Dominant state is represented by logic level '0'. Recessive state is represented by logic level '1'.

24.2.2.2 CAN Tx

This pin is the transmit pin to the CAN bus transceiver. Dominant state is represented by logic level '0'. Recessive state is represented by logic level '1'.

24.3 Memory Map/Register Definition

This section describes the registers and data structures in the FlexCAN module. The base address of the module depends on the particular memory map of the MCU. The addresses presented here are relative to the base address.

The address space occupied by FlexCAN has 96 bytes for registers starting at the module base address, followed by MB storage space in embedded RAM starting at address 0x0060, and an extra ID Mask storage space in a separate embedded RAM starting at address 0x0880.

24.3.1 FlexCAN Memory Mapping

The complete memory map for a FlexCAN module with 64 MBs capability is shown in [Table 24-2](#). Each individual register is identified by its complete name and the corresponding mnemonic. The access type is always Supervisor (S).

The FLEXCAN_x_IFLAG2 and FLEXCAN_x_IMASK2 registers are considered reserved space when FlexCAN is configured with 16 or 32 MBs. The Rx Global Mask (FLEXCAN_x_RXGMASK), Rx Buffer 14 Mask (FLEXCAN_x_RX14MASK) and the Rx Buffer 15 Mask (FLEXCAN_x_RX15MASK)

registers are provided for backwards compatibility, and are not used when the MBFEN bit in FLEXCAN_x_MCR is asserted.

The address ranges 0x0060–0x047F and 0x0880–0x097F are occupied by two separate embedded memories. These two ranges are completely occupied by RAM (1056 and 256 bytes, respectively) only when FlexCAN is configured with 64 MBs. When it is configured with 16 MBs, the memory sizes are 288 and 64 bytes, so the address ranges 0x0180–0x047F and 0x08C0–0x097F are considered reserved space. When it is configured with 32 MBs, the memory sizes are 544 and 128 bytes, so the address ranges 0x0280–0x047F and 0x0900–0x097F are considered reserved space. Furthermore, if the MBFEN bit in FLEXCAN_x_MCR is negated, then the whole Rx Individual Mask Registers address range (0x0880–0x097F) is considered reserved space.

Table 24-2. Module Memory Map

| Address ¹ | Register | Bits | Access | Reset Value | Affected by Hard Reset | Affected by Soft Reset | Section/Page |
|----------------------|--|------|--------|-------------|------------------------|------------------------|------------------------------|
| Base + 0x0000 | FLEXCAN_x_MCR—Module Configuration | 32 | S | 0x5990_000F | Yes | Yes | 24.3.4.1/14 |
| Base + 0x0004 | FLEXCAN_x_CTRL—Control Register | 32 | S | 0x0000_0000 | Yes | No | 24.3.4.2/18 |
| Base + 0x0008 | FLEXCAN_x_TIMER—Free Running Timer | 32 | S | 0x0000_0000 | Yes | Yes | 24.3.4.3/21 |
| Base + 0x000C | Reserved | | | | | | |
| Base + 0x0010 | FLEXCAN_x_RXGMASK—Rx Global Mask | 32 | S | 0xFFFF_FFFF | Yes | No | 24.3.4.4/22 |
| Base + 0x0014 | FLEXCAN_x_RX14MASK—Rx Buffer 14 Mask | 32 | S | 0xFFFF_FFFF | Yes | No | 24.3.4.5/22 |
| Base + 0x0018 | FLEXCAN_x_RX15MASK—Rx Buffer 15 Mask | 32 | S | 0xFFFF_FFFF | Yes | No | 24.3.4.6/23 |
| Base + 0x001C | FLEXCAN_x_ECR—Error Counter Register | 32 | S | 0x0000_0000 | Yes | Yes | 24.3.4.7/23 |
| Base + 0x0020 | FLEXCAN_x_ESR—Error and Status Register | 32 | S | 0x0000_0000 | Yes | Yes | 24.3.4.8/25 |
| Base + 0x0024 | FLEXCAN_x_IMASK2—Interrupt Masks 2 | 32 | S | 0x0000_0000 | Yes | Yes | 24.3.4.9/28 |
| Base + 0x0028 | FLEXCAN_x_IMASK1—Interrupt Masks 1 | 32 | S | 0x0000_0000 | Yes | Yes | 24.3.4.10/28 |
| Base + 0x002C | FLEXCAN_x_IFLAG2—Interrupt Flags 2 | 32 | S | 0x0000_0000 | Yes | Yes | 24.3.4.11/29 |
| Base + 0x0030 | FLEXCAN_x_IFLAG1—Interrupt Flags 1 | 32 | S | 0x0000_0000 | Yes | Yes | 24.3.4.12/30 |
| Base + 0x0034–0x005F | Reserved | | | | | | |
| Base + 0x0060–0x007F | Reserved | | | | | | |
| Base + 0x0080–0x017F | Message Buffers MB0–MB15 | — | S | — | No | No | — |
| Base + 0x0180–0x027F | Message Buffers MB16–MB31 | — | S | — | No | No | — |
| Base + 0x0280–0x047F | Message Buffers MB32–MB63 | — | S | — | No | No | — |
| Base + 0x0480–0x087F | Reserved | | | | | | |
| Base + 0x0880–0x08BF | RXIMR0–RXIMR15—Rx Individual Mask Registers | | S | | No | No | 24.3.4.13/32 |
| Base + 0x08C0–0x08FF | RXIMR16–RXIMR31—Rx Individual Mask Registers | | S | | No | No | 24.3.4.13/32 |
| Base + 0x0900–0x097F | RXIMR32–RXIMR63—Rx Individual Mask Registers | | S | | No | No | 24.3.4.13/32 |

NOTES:

- ¹ FLEXCAN_A = 0xFFFC_0000
- FLEXCAN_B = 0xFFFC_4000
- FLEXCAN_C = 0xFFFC_8000
- FLEXCAN_D = 0xFFFC_C000

The FlexCAN module stores CAN messages for transmission and reception using a Message Buffer structure. Each individual MB is formed by 16 bytes mapped in memory as described in [Table 24-3](#). [Table 24-3](#) shows a Standard/Extended Message Buffer (MB0) memory map, using 16 bytes total (0x80–0x8F space).

Table 24-3. Message Buffer MB0 Memory Mapping

| Address Offset | MB Field |
|----------------|---|
| 0x80 | Control and Status (C/S) |
| 0x84 | Identifier Field |
| 0x88–0x8F | Data Field 0 – Data Field 7 (1 byte each) |

24.3.2 Message Buffer Structure

The Message Buffer structure used by the FlexCAN module is represented in [Figure 24-2](#). Both Extended and Standard Frames (29-bit Identifier and 11-bit Identifier, respectively) used in the CAN specification (Version 2.0 Part B) are represented.

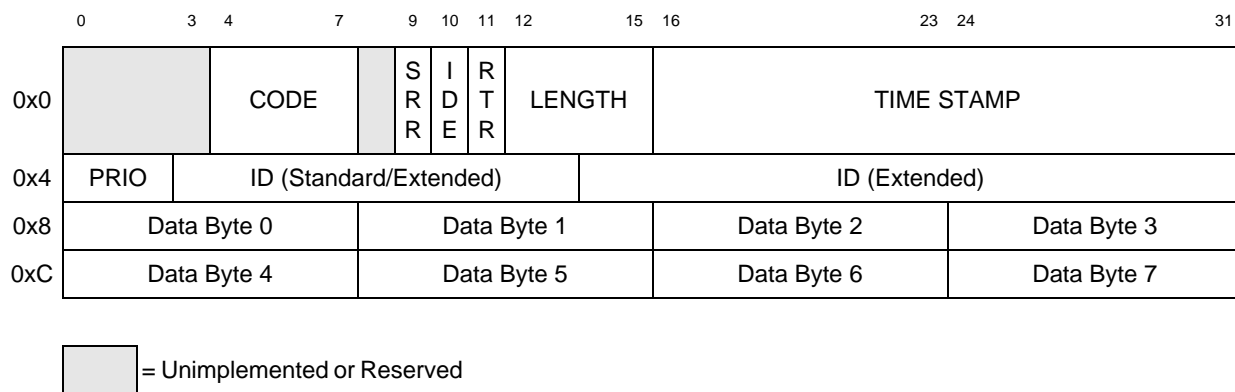

Figure 24-2. Message Buffer Structure

Table 24-4. Message Buffer Structure Field Descriptions

| Field | Description |
|------------|---|
| CODE | <p>Message Buffer Code</p> <p>This 4-bit field can be accessed (read or write) by the CPU and by the Flexcan module itself, as part of the message buffer matching and arbitration process. The encoding is shown in Table 24-5 and Table 24-6. See Section 24.4, Functional Description, for additional information.</p> |
| SRR | <p>Substitute Remote Request</p> <p>Fixed recessive bit, used only in extended format. It must be set to '1' by the user for transmission (Tx Buffers) and will be stored with the value received on the CAN bus for Rx receiving buffers. It can be received as either recessive or dominant. If FlexCAN receives this bit as dominant, then it is interpreted as arbitration loss.</p> <p>0 Dominant is not a valid value for transmission in Extended Format frames 1 Recessive value is compulsory for transmission in Extended Format frames</p> |
| IDE | <p>ID Extended Bit</p> <p>This bit identifies whether the frame format is standard or extended.</p> <p>0 Frame format is standard 1 Frame format is extended</p> |
| RTR | <p>Remote Transmission Request</p> <p>This bit is used for requesting transmissions of a data frame. If FlexCAN transmits this bit as '1' (recessive) and receives it as '0' (dominant), it is interpreted as arbitration loss. If this bit is transmitted as '0' (dominant), then if it is received as '1' (recessive), the FlexCAN module treats it as bit error. If the value received matches the value transmitted, it is considered as a successful bit transmission.</p> <p>0 Indicates the current MB has a Data Frame to be transmitted 1 Indicates the current MB has a Remote Frame to be transmitted</p> |
| LENGTH | <p>Length of Data in Bytes</p> <p>This 4-bit field is the length (in bytes) of the Rx or Tx data, which is located in offset 0x8 through 0xF of the MB space (see Figure 24-2). In reception, this field is written by the FlexCAN module, copied from the DLC (Data Length Code) field of the received frame. In transmission, this field is written by the CPU and corresponds to the DLC field value of the frame to be transmitted. When RTR=1, the Frame to be transmitted is a Remote Frame and does not include the data field, regardless of the Length field.</p> |
| TIME STAMP | <p>Free-Running Counter Time Stamp</p> <p>This 16-bit field is a copy of the Free-Running Timer, captured for Tx and Rx frames at the time when the beginning of the Identifier field appears on the CAN bus.</p> |
| PRIO | <p>Local priority</p> <p>This 3-bit field is only used when LPRIO_EN bit is set in FLEXCAN_x_MCR and it only makes sense for Tx buffers. These bits are not transmitted. They are appended to the regular ID to define the transmission priority. See Section 24.4.3, Arbitration process.</p> |
| ID | <p>Frame Identifier</p> <p>In Standard Frame format, only the 11 most significant bits (3 to 13) are used for frame identification in both receive and transmit cases. The 18 least significant bits are ignored. In Extended Frame format, all bits are used for frame identification in both receive and transmit cases.</p> |
| DATA | <p>Data Field</p> <p>Up to eight bytes can be used for a data frame. For Rx frames, the data is stored as it is received from the CAN bus. For Tx frames, the CPU prepares the data field to be transmitted within the frame.</p> |

Table 24-5. Message Buffer Code for Rx buffers

| Rx Code BEFORE Rx New Frame | Description | Rx Code AFTER Rx New Frame | Comment |
|-----------------------------|---|----------------------------|---|
| 0000 | INACTIVE: MB is not active. | – | MB does not participate in the matching process. |
| 0100 | EMPTY: MB is active and empty. | 0010 | MB participates in the matching process. When a frame is received successfully, the code is automatically updated to FULL. |
| 0010 | FULL: MB is full. | 0010 | The act of reading the C/S word followed by unlocking the MB does not make the code return to EMPTY. It remains FULL. If a new frame is written to the MB after the C/S word was read and the MB was unlocked, the code still remains FULL. |
| | | 0110 | If the MB is FULL and a new frame is overwritten to this MB before the CPU had time to read it, the code is automatically updated to OVERRUN. Refer to Section 24.4.5, Matching Process , for details about overrun behavior. |
| 0110 | OVERRUN: a frame was overwritten into a full buffer. | 0010 | If the code indicates OVERRUN but the CPU reads the C/S word and then unlocks the MB, when a new frame is written to the MB the code returns to FULL. |
| | | 0110 | If the code already indicates OVERRUN, and yet another new frame must be written, the MB will be overwritten again, and the code will remain OVERRUN. Refer to Section 24.4.5, Matching Process , for details about overrun behavior. |
| 0XY1 ¹ | BUSY: Flexcan is updating the contents of the MB. The CPU must not access the MB. | 0010 | An EMPTY buffer was written with a new frame (XY was 01). |
| | | 0110 | A FULL/OVERRUN buffer was overwritten (XY was 11). |

NOTES:

¹ Note that for Tx MBs (see [Table 24-6](#)), the BUSY bit should be ignored upon read, except when AEN bit is set in the FLEXCAN_x_MCR register.

Table 24-6. Message Buffer Code for Tx buffers

| RTR | Initial Tx code | Code after successful transmission | Description |
|-----|-----------------|------------------------------------|---|
| X | 1000 | – | INACTIVE: MB does not participate in the arbitration process. |
| X | 1001 | – | ABORT: MB was configured as Tx and CPU aborted the transmission. This code is only valid when AEN bit in FLEXCAN_x_MCR is asserted. MB does not participate in the arbitration process. |
| 0 | 1100 | 1000 | Transmit data frame unconditionally once. After transmission, the MB automatically returns to the INACTIVE state. |

Table 24-6. Message Buffer Code for Tx buffers (continued)

| RTR | Initial Tx code | Code after successful transmission | Description |
|-----|-----------------|------------------------------------|--|
| 1 | 1100 | 0100 | Transmit remote frame unconditionally once. After transmission, the MB automatically becomes an Rx MB with the same ID. |
| 0 | 1010 | 1010 | Transmit a data frame whenever a remote request frame with the same ID is received. This MB participates simultaneously in both the matching and arbitration processes. The matching process compares the ID of the incoming remote request frame with the ID of the MB. If a match occurs this MB is allowed to participate in the current arbitration process and the Code field is automatically updated to '1110' to allow the MB to participate in future arbitration runs. When the frame is eventually transmitted successfully, the Code automatically returns to '1010' to restart the process again. |
| 0 | 1110 | 1010 | This is an intermediate code that is automatically written to the MB by the MBM as a result of match to a remote request frame. The data frame will be transmitted unconditionally once and then the code will automatically return to '1010'. The CPU can also write this code with the same effect. |

24.3.3 Rx FIFO Structure

When the FEN bit is set in the FLEXCAN_x_MCR, the memory area from 0x80 to 0xFC (which is normally occupied by MBs 0 to 7) is used by the reception FIFO engine. [Figure 24-3](#) shows the Rx FIFO data structure. The region 0x80-0x8C contains an MB structure which is the port through which the CPU reads data from the FIFO (the oldest frame received and not read yet). The region 0x90-0xDC is reserved for internal use of the FIFO engine. The region 0xE0-0xFC contains an 8-entry ID table that specifies filtering criteria for accepting frames into the FIFO. [Figure 24-4](#) shows the three different formats that the elements of the ID table can assume, depending on the IDAM field of the FLEXCAN_x_MCR. Note that all elements of the table must have the same format. See [Section 24.4.7, Rx FIFO](#), for more information.

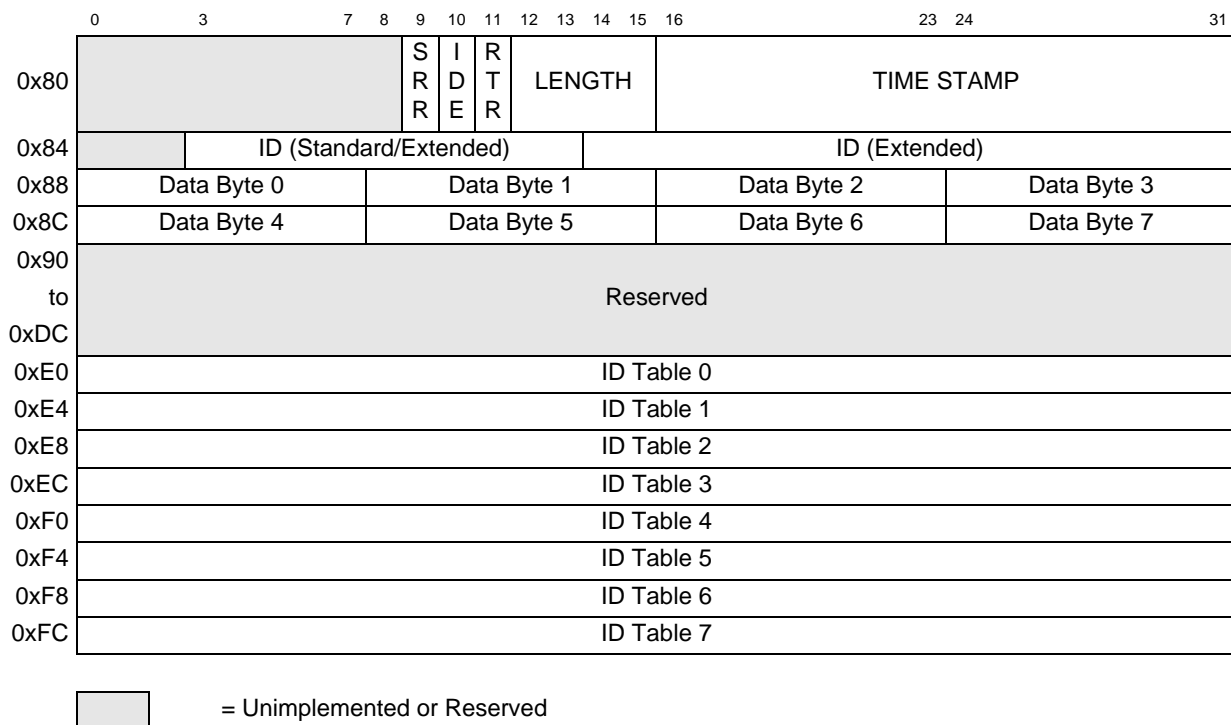
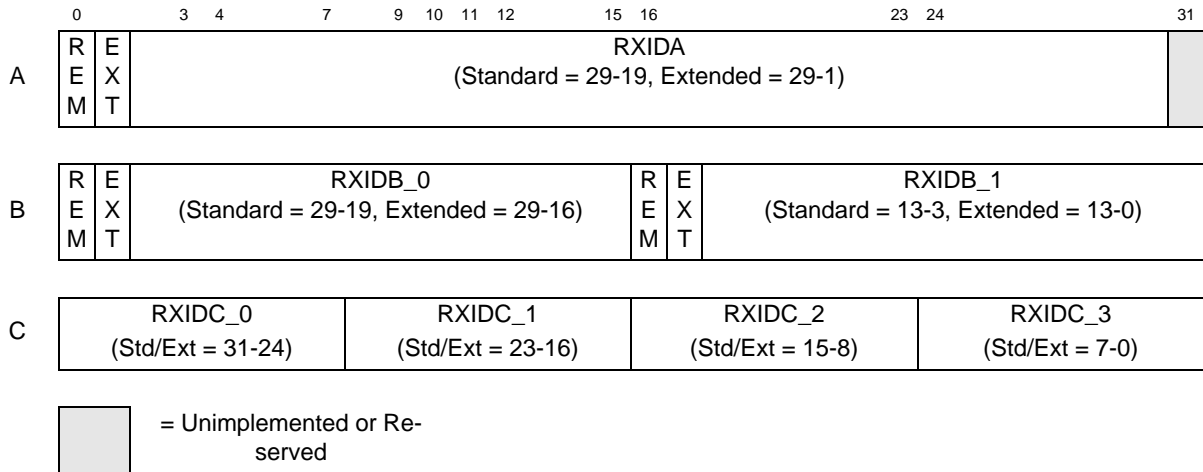

Figure 24-3. Rx FIFO Structure

Figure 24-4. ID Table 0 - 7
Table 24-7. Rx FIFO Structure Field Descriptions

| Field | Description |
|--|--|
| REM | Remote Frame This bit specifies if Remote Frames are accepted into the FIFO if they match the target ID. 0 Remote Frames are rejected and data frames can be accepted 1 Remote Frames can be accepted and data frames are rejected |
| EXT | Extended Frame Specifies whether extended or standard frames are accepted into the FIFO if they match the target ID. 0 Extended frames are rejected and standard frames can be accepted 1 Extended frames can be accepted and standard frames are rejected |
| RXIDA | Rx Frame Identifier (Format A) Specifies an ID to be used as acceptance criteria for the FIFO. In the standard frame format, only the 11 most significant bits (3 to 13) are used for frame identification. In the extended frame format, all bits are used. |
| RXIDB_0 RXIDB_1 | Rx Frame Identifier (Format B) Specifies an ID to be used as acceptance criteria for the FIFO. In the standard frame format, the 11 most significant bits (a full standard ID) (3 to 13) are used for frame identification. In the extended frame format, all 14 bits of the field are compared to the 14 most significant bits of the received ID. |
| RXIDC_0 RXIDC_1 RXIDC_2 RXIDC_3 | Rx Frame Identifier (Format C) Specifies an ID to be used as acceptance criteria for the FIFO. In both standard and extended frame formats, all 8 bits of the field are compared to the 8 most significant bits of the received ID. |

24.3.4 Register Descriptions

The FlexCAN registers are described in this section in ascending address order.

24.3.4.1 Module Configuration Register (FLEXCAN_x_MCR)

This register defines global system configurations, such as the module operation mode (e.g., low power) and maximum message buffer configuration. Most of the fields in this register can be accessed at any time, except the MAXMB field, which should only be changed while the module is in Freeze Mode.

Base + 0x0000

| | | | | | | | | | | | | | | | | |
|--------|------|-----|-----------|------|---------|----|----------|---------|------|-------|--------|----------|----|------|---------|--------|
| | 0 | 1 | 2 | 3 | 4 | 5 | 6 | 7 | 8 | 9 | 10 | 11 | 12 | 13 | 14 | 15 |
| R | MDIS | FRZ | FEN | HALT | NOT_RDY | 0 | SOFT_RST | FRZ_ACK | SUPV | 0 | WRN_EN | MDI-SACK | 0 | DOZE | SRX_DIS | MBF_EN |
| W | | | | | | | | | | | | | | | | |
| RESET: | 0 | 1 | 0 | 1 | 1 | 0 | 0 | 1 | 1 | 0 | 0 | 1 | 0 | 0 | 0 | 0 |
| | 16 | 17 | 18 | 19 | 20 | 21 | 22 | 23 | 24 | 25 | 26 | 27 | 28 | 29 | 30 | 31 |
| R | 0 | 0 | LPRI_O_EN | AEN | 0 | 0 | IDAM | 0 | 0 | MAXMB | | | | | | |
| W | | | | | | | | | | | | | | | | |
| RESET: | 0 | 0 | 0 | 0 | 0 | 0 | 0 | 0 | 0 | 0 | 0 | 0 | 1 | 1 | 1 | 1 |

Figure 24-5. Module Configuration Register (FLEXCAN_x_MCR)

Table 24-8. FLEXCAN_x_MCR Field Descriptions

| Field | Description |
|-----------|--|
| 0 MDIS | <p>Module Disable</p> <p>This bit controls whether FlexCAN is enabled or not. When disabled, FlexCAN shuts down the clocks to the CAN Protocol Interface and Message Buffer Management sub-modules. This is the only bit in FLEXCAN_x_MCR not affected by soft reset. See Section 24.4.9.2, Module Disable Mode, for more information.</p> <p>0 Enable the FlexCAN module 1 Disable the FlexCAN module</p> |
| 1 FRZ | <p>Freeze Enable</p> <p>The FRZ bit specifies the FlexCAN behavior when the HALT bit in the FLEXCAN_x_MCR Register is set or when Debug Mode is requested at MCU level. When FRZ is asserted, FlexCAN is enabled to enter Freeze Mode. Negation of this bit field causes FlexCAN to exit from Freeze Mode.</p> <p>0 Not enabled to enter Freeze Mode 1 Enabled to enter Freeze Mode</p> |
| 2 FEN | <p>FIFO Enable</p> <p>This bit controls whether the FIFO feature is enabled or not. When FEN is set, MBs 0 to 7 cannot be used for normal reception and transmission because the corresponding memory region (0x80-0xFF) is used by the FIFO engine. See Section 24.3.3, Rx FIFO Structure and Section 24.4.7, Rx FIFO, for more information.</p> <p>0 FIFO not enabled 1 FIFO enabled</p> |

Table 24-8. FLEXCAN_x_MCR Field Descriptions (continued)

| Field | Description |
|---------------|--|
| 3 HALT | <p>Halt FlexCAN Assertion of this bit puts the FlexCAN module into Freeze Mode. The CPU should clear it after initializing the Message Buffers and Control Register. No reception or transmission is performed by FlexCAN before this bit is cleared. While in Freeze Mode, the CPU has write access to the Error Counter Register, that is otherwise read-only. Freeze Mode can not be entered while FlexCAN is in any of the low power modes. See Section 24.4.9.1, Freeze Mode, for more information.</p> <p>0 No Freeze Mode request. 1 Enters Freeze Mode if the FRZ bit is asserted.</p> |
| 4 NOT_RDY | <p>FlexCAN Not Ready This read-only bit indicates that FlexCAN is either in Disable Mode, Stop Mode or Freeze Mode. It is negated once FlexCAN has exited these modes.</p> <p>0 FlexCAN module is either in Normal Mode, Listen-Only Mode or Loop-Back Mode 1 FlexCAN module is either in Disable Mode, Stop Mode or Freeze Mode</p> |
| 5 | Reserved |
| 6 SOFT_RST | <p>Soft Reset When this bit is asserted, FlexCAN resets its internal state machines and some of the memory mapped registers. The following registers are reset: FLEXCAN_x_MCR (except the MDIS bit), FLEXCAN_x_TIMER, FLEXCAN_x_ECR, FLEXCAN_x_ESR, FLEXCAN_x_IMASK1, FLEXCAN_x_IMASK2, FLEXCAN_x_IFLAG1, FLEXCAN_x_IFLAG2. Configuration registers that control the interface to the CAN bus are not affected by soft reset. The following registers are unaffected:</p> <ul style="list-style-type: none"> • FLEXCAN_x_CTRL • RXIMR0–RXIMR63 • FLEXCAN_x_RXGMASK, FLEXCAN_x_RX14MASK, FLEXCAN_x_RX15MASK • all Message Buffers <p>The SOFT_RST bit can be asserted directly by the CPU when it writes to the FLEXCAN_x_MCR Register, but it is also asserted when global soft reset is requested at MCU level. Since soft reset is synchronous and has to follow a request/acknowledge procedure across clock domains, it may take some time to fully propagate its effect. The SOFT_RST bit remains asserted while reset is pending, and is automatically negated when reset completes. Therefore, software can poll this bit to know when the soft reset has completed.</p> <p>Soft reset cannot be applied while clocks are shut down in any of the low power modes. The module should be first removed from low power mode, and then soft reset can be applied.</p> <p>0 No reset request 1 Resets the registers marked as “affected by soft reset” in Table 24-2</p> |
| 7 FRZ_ACK | <p>Freeze Mode Acknowledge This read-only bit indicates that FlexCAN is in Freeze Mode and its prescaler is stopped. The Freeze Mode request cannot be granted until current transmission or reception processes have finished. Therefore the software can poll the FRZ_ACK bit to know when FlexCAN has actually entered Freeze Mode. If Freeze Mode request is negated, then this bit is negated once the FlexCAN prescaler is running again. If Freeze Mode is requested while FlexCAN is in any of the low power modes, then the FRZ_ACK bit will only be set when the low power mode is exited. See Section 24.4.9.1, Freeze Mode, for more information.</p> <p>0 FlexCAN not in Freeze Mode, prescaler running 1 FlexCAN in Freeze Mode, prescaler stopped</p> |

Table 24-8. FLEXCAN_x_MCR Field Descriptions (continued)

| Field | Description |
|---------------|---|
| 8 SUPV | <p>Supervisor Mode</p> <p>Although the FlexCAN module provides a differentiation between Supervisor and User access types, all accesses will be always considered of the Supervisor type. As a consequence, the SUPV bit in the Module Configuration Register (FLEXCAN_x_MCR) has no effect on the module behavior.</p> <p>1 Affected registers are in Supervisor memory space. Any access without supervisor permission behaves as though the access was done to an unimplemented register location</p> |
| 9 | Reserved |
| 10 WRN_EN | <p>Warning Interrupt Enable</p> <p>When asserted, this bit enables the generation of the TWRN_INT and RWRN_INT flags in the Error and Status Register. If WRN_EN is negated, the TWRN_INT and RWRN_INT flags will always be zero, independent of the values of the error counters, and no warning interrupt will ever be generated.</p> <p>0 TWRN_INT and RWRN_INT bits are zero, independent of the values in the error counters. 1 TWRN_INT and RWRN_INT bits are set when the respective error counter transition from <96 to ≥ 96.</p> |
| 11 MDISACK | <p>Module Disable Acknowledge</p> <p>This read-only bit indicates that FlexCAN is either in Disable Mode or Stop Mode. Either of these low power modes can not be entered until all current transmission or reception processes have finished, so the CPU can poll the MDISACK bit to know when FlexCAN has actually entered low power mode. See Section 24.4.9.2, Module Disable Mode, and Section 24.4.9.3, Stop Mode, for more information.</p> <p>0 FlexCAN not in any of the low power modes 1 FlexCAN is either in Disable Mode or Stop mode</p> |
| 12 | Reserved |
| 13 DOZE | <p>Doze Mode Enable</p> <p>Doze Mode is not supported on this device. Leave this bit as '0'.</p> <p>0 FlexCAN is not enabled to enter low power mode when Doze Mode is requested</p> |
| 14 SRX_DIS | <p>Self Reception Disable</p> <p>This bit defines whether FlexCAN is allowed to receive frames transmitted by itself. If this bit is asserted, frames transmitted by the module will not be stored in any MB, regardless if the MB is programmed with an ID that matches the transmitted frame, and no interrupt flag or interrupt signal will be generated due to the frame reception.</p> <p>0 Self reception enabled 1 Self reception disabled</p> |
| 15 MBFEN | <p>Message buffer filter enable. This bit provides the capability of enabling either individual masking of every message buffer, or global masking of message buffers.</p> <p>This bit is provided to support backwards compatibility with previous FlexCAN versions. When this bit is negated, the following configuration is applied:</p> <ul style="list-style-type: none"> Individual Rx ID masking is disabled. Instead of individual ID masking per MB, FlexCAN uses its previous masking scheme with FLEXCAN_x_RXGMASK, FLEXCAN_x_RX14MASK and FLEXCAN_x_RX15MASK. The reception queue feature is disabled. Upon receiving a message, if the first MB with a matching ID that is found is still occupied by a previous unread message, FlexCAN will not look for another matching MB. It will override this MB with the new message and set the CODE field to '0110' (overrun). Upon reset this bit is negated, allowing legacy software to work without modification. <p>0 Individual Rx masking and queue feature are disabled. 1 Individual Rx masking and queue feature are enabled.</p> |
| 16–17 | Reserved |

Table 24-8. FLEXCAN_x_MCR Field Descriptions (continued)

| Field | Description |
|----------------|--|
| 18 LPRIO_EN | Local Priority Enable This bit is provided for backwards compatibility reasons. It controls whether the local priority feature is enabled or not. It is used to extend the ID used during the arbitration process. With this extended ID concept, the arbitration process is done based on the full 32-bit word, but the actual transmitted ID still has 11-bit for standard frames and 29-bit for extended frames. 0 Local Priority disabled 1 Local Priority enabled |
| 19 AEN | Abort Enable This bit is supplied for backwards compatibility reasons. When asserted, it enables the Tx abort feature. This feature guarantees a safe procedure for aborting a pending transmission, so that no frame is sent in the CAN bus without notification. 0 Abort disabled 1 Abort enabled |
| 20–21 | Reserved |
| 22–23 IDAM | ID Acceptance Mode This 2-bit field identifies the format of the elements of the Rx FIFO filter table, as shown in Table 24-9 . Note that all elements of the table are configured at the same time by this field (they are all the same format). See Section 24.3.3, Rx FIFO Structure . |
| 24–25 | Reserved |
| 26–31 MAXMB | Maximum Number of Message Buffers This 6-bit field defines the maximum number of message buffers that will take part in the matching and arbitration processes. The reset value (0x0F) is equivalent to 16 MB configuration. This field should be changed only while the module is in Freeze Mode. Maximum MBs in use = MAXMB + 1. Note: MAXMB must be programmed with a value smaller or equal to the number of available Message Buffers, otherwise FlexCAN can transmit and receive wrong messages. |

Table 24-9. IDAM Coding

| IDAM | Format | Explanation |
|------|--------|--|
| 00 | A | One full ID (standard or extended) per filter element. |
| 01 | B | Two full standard IDs or two partial 14-bit extended IDs per filter element. |
| 10 | C | Four partial 8-bit IDs (standard or extended) per filter element. |
| 11 | D | All frames rejected. |

24.3.4.2 Control Register (FLEXCAN_x_CTRL)

This register is defined for specific FlexCAN control features related to the CAN bus, such as bit-rate, programmable sampling point within an Rx bit, Loop Back Mode, Listen Only Mode, Bus Off recovery behavior and interrupt enabling (Bus-Off, Error, Warning). It also determines the Division Factor for the clock prescaler. Most of the fields in this register should only be changed while the module is in Disable Mode or in Freeze Mode. Exceptions are the BOFF_MSK, ERR_MSK, TWRN_MSK, RWRN_MSK and BOFF_REC bits, that can be accessed at any time.

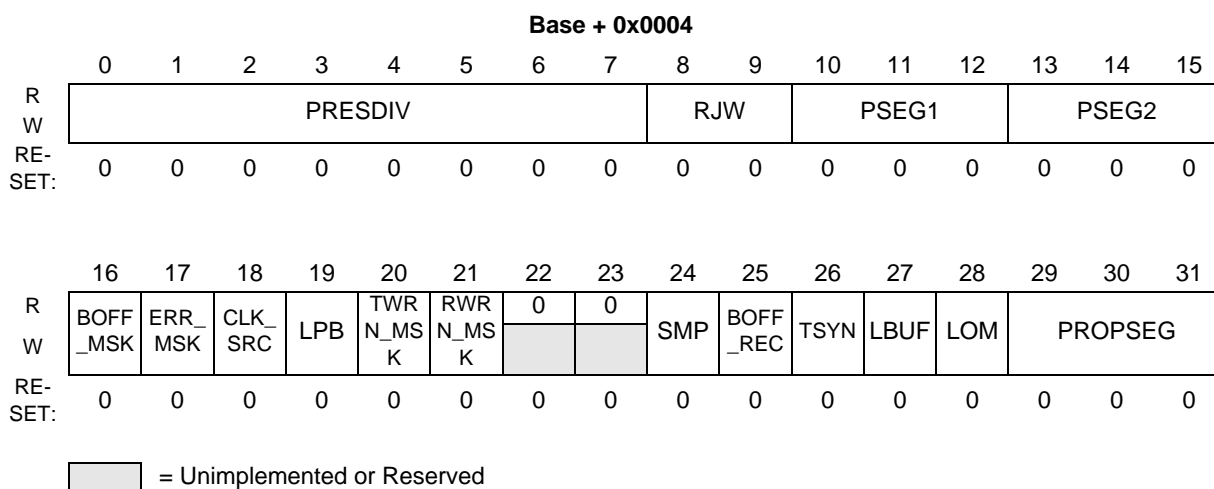

Figure 24-6. Control Register (FLEXCAN_x_CTRL)

Table 24-10. FLEXCAN_x_CTRL Field Descriptions

| Field | Description |
|-----------------|---|
| 0–7 PRES DIV | Prescaler Division Factor This 8-bit field defines the ratio between the CPI clock frequency and the Serial Clock (Sclock) frequency. The Sclock period defines the time quantum of the CAN protocol. For the reset value, the Sclock frequency is equal to the CPI clock frequency. The Maximum value of this register is 0xFF, that gives a minimum Sclock frequency equal to the CPI clock frequency divided by 256. For more information refer to Section 24.4.8.4, Protocol Timing . Sclock frequency = CPI clock frequency / (PRES DIV + 1) |
| 8–9 RJW | Resync Jump Width This 2-bit field defines the maximum number of time quanta ¹ that a bit time can be changed by one re-synchronization. The valid programmable values are 0–3. Resync Jump Width = RJW + 1. |
| 10–12 PSEG1 | Phase Segment 1 This 3-bit field defines the length of Phase Buffer Segment 1 in the bit time. The valid programmable values are 0–7. Phase Buffer Segment 1 = (PSEG1 + 1) x Time-Quanta. |
| 13–15 PSEG2 | Phase Segment 2 This 3-bit field defines the length of Phase Buffer Segment 2 in the bit time. The valid programmable values are 1–7. Phase Buffer Segment 2 = (PSEG2 + 1) x Time-Quanta. |
| 16 BOFF_MSK | Bus Off Mask This bit provides a mask for the Bus Off Interrupt. 0 Bus Off interrupt disabled 1 Bus Off interrupt enabled |

Table 24-10. FLEXCAN_x_CTRL Field Descriptions (continued)

| Field | Description |
|----------------|---|
| 17 ERR_MSK | <p>Error Mask</p> <p>This bit provides a mask for the Error Interrupt.</p> <p>0 Error interrupt disabled 1 Error interrupt enabled</p> |
| 18 CLK_SRC | <p>CAN Engine Clock Source</p> <p>This bit selects the clock source to the CAN Protocol Interface (CPI) to be either the system clock (driven by the PLL) or the crystal oscillator clock (direct feed from the oscillator pin EXTAL). The selected clock is the one fed to the prescaler to generate the Serial Clock (Sclk). In order to guarantee reliable operation, this bit should only be changed while the module is in Disable Mode. See Section 24.4.8.4, Protocol Timing, for more information.</p> <p>0 The CAN engine clock source is the oscillator clock 1 The CAN engine clock source is the bus clock</p> |
| 19 TWRN_MSK | <p>Tx Warning Interrupt Mask</p> <p>This bit provides a mask for the Tx Warning Interrupt associated with the TWRN_INT flag in the Error and Status Register. This bit has no effect if the WRN_EN bit in FLEXCAN_x_MCR is negated and it is read as zero when WRN_EN is negated.</p> <p>0 Tx Warning Interrupt disabled 1 Tx Warning Interrupt enabled</p> |
| 20 RWRN_MSK | <p>Rx Warning Interrupt Mask</p> <p>This bit provides a mask for the Rx Warning Interrupt associated with the RWRN_INT flag in the Error and Status Register. This bit has no effect if the WRN_EN bit in FLEXCAN_x_MCR is negated and it is read as zero when WRN_EN is negated.</p> <p>0 Rx Warning Interrupt disabled 1 Rx Warning Interrupt enabled</p> |
| 21 LPB | <p>Loop Back</p> <p>This bit configures FlexCAN to operate in Loop-Back Mode. In this mode, FlexCAN performs an internal loop back that can be used for self test operation. The bit stream output of the transmitter is fed back internally to the receiver input. The Rx CAN input pin is ignored and the Tx CAN output goes to the recessive state (logic '1'). FlexCAN behaves as it normally does when transmitting, and treats its own transmitted message as a message received from a remote node. In this mode, FlexCAN ignores the bit sent during the ACK slot in the CAN frame acknowledge field, generating an internal acknowledge bit to ensure proper reception of its own message. Both transmit and receive interrupts are generated.</p> <p>0 Loop Back disabled 1 Loop Back enabled</p> |
| 22–23 | Reserved |
| 24 SMP | <p>Sampling Mode</p> <p>This bit defines the sampling mode of CAN bits at the Rx input.</p> <p>0 Just one sample is used to determine the bit value 1 Three samples are used to determine the value of the received bit: the regular one (sample point) and 2 preceding samples, a majority rule is used</p> |

Table 24-10. FLEXCAN_x_CTRL Field Descriptions (continued)

| Field | Description |
|------------------|--|
| 25 BOFF_REC | <p>Bus Off Recovery Mode</p> <p>This bit defines how FlexCAN recovers from Bus Off state. If this bit is negated, automatic recovering from Bus Off state occurs according to the CAN Specification 2.0B. If the bit is asserted, automatic recovering from Bus Off is disabled and the module remains in Bus Off state until the bit is negated by the user. If the negation occurs before 128 sequences of 11 recessive bits are detected on the CAN bus, then Bus Off recovery happens as if the BOFF_REC bit had never been asserted. If the negation occurs after 128 sequences of 11 recessive bits occurred, then FlexCAN will re-synchronize to the bus by waiting for 11 recessive bits before joining the bus. After negation, the BOFF_REC bit can be re-asserted again during Bus Off, but it will only be effective the next time the module enters Bus Off. If BOFF_REC was negated when the module entered Bus Off, asserting it during Bus Off will not be effective for the current Bus Off recovery.</p> <p>0 Automatic recovering from Bus Off state enabled, according to CAN Spec 2.0 part B 1 Automatic recovering from Bus Off state disabled</p> |
| 26 TSYN | <p>Timer Sync Mode</p> <p>This bit enables a mechanism that resets the free-running timer each time a message is received in Message Buffer 0. This feature provides means to synchronize multiple FlexCAN stations with a special “SYNC” message (i.e., global network time). If the FEN bit in FLEXCAN_x_MCR is set (FIFO enabled), MB8 is used for timer synchronization instead of MB0.</p> <p>0 Timer Sync feature disabled 1 Timer Sync feature enabled</p> |
| 27 LBUF | <p>Lowest Buffer Transmitted First</p> <p>This bit defines the ordering mechanism for Message Buffer transmission. When asserted, the LPRIO_EN bit does not affect the priority arbitration.</p> <p>0 Buffer with highest priority is transmitted first 1 Lowest number buffer is transmitted first</p> |
| 28 LOM | <p>Listen-Only Mode</p> <p>This bit configures FlexCAN to operate in Listen Only Mode. In this mode, transmission is disabled, all error counters are frozen and the module operates in a CAN Error Passive mode [Ref. 1]. Only messages acknowledged by another CAN station will be received. If FlexCAN detects a message that has not been acknowledged, it will flag a BIT0 error (without changing the REC), as if it was trying to acknowledge the message.</p> <p>0 Listen Only Mode is deactivated 1 FlexCAN module operates in Listen Only Mode</p> |
| 29–31 PROPSEG | <p>Propagation Segment</p> <p>This 3-bit field defines the length of the Propagation Segment in the bit time. The valid programmable values are 0–7.</p> <p>Propagation Segment Time = (PROPSEG + 1) * Time-Quanta. Time-Quantum = one Sclock period.</p> |

NOTES:

¹ One time quantum is equal to the Sclock period.

24.3.4.3 Free Running Timer (FLEXCAN_x_TIMER)

This register represents a 16-bit free running counter that can be read and written by the CPU. The timer starts from 0x0000 after Reset, counts linearly to 0xFFFF, and wraps around.

The timer is clocked by the FlexCAN bit-clock (which defines the baud rate on the CAN bus). During a message transmission/reception, it increments by one for each bit that is received or transmitted. When there is no message on the bus, it counts using the previously programmed baud rate. During Freeze Mode, the timer is not incremented.

The timer value is captured at the beginning of the identifier field of any frame on the CAN bus. This captured value is written into the Time Stamp entry in a message buffer after a successful reception or transmission of a message.

Writing to the timer is an indirect operation. The data is first written to an auxiliary register and then an internal request/acknowledge procedure across clock domains is executed. All this is transparent to the user, except for the fact that the data will take some time to be actually written to the register. If desired, software can poll the register to discover when the data was actually written.

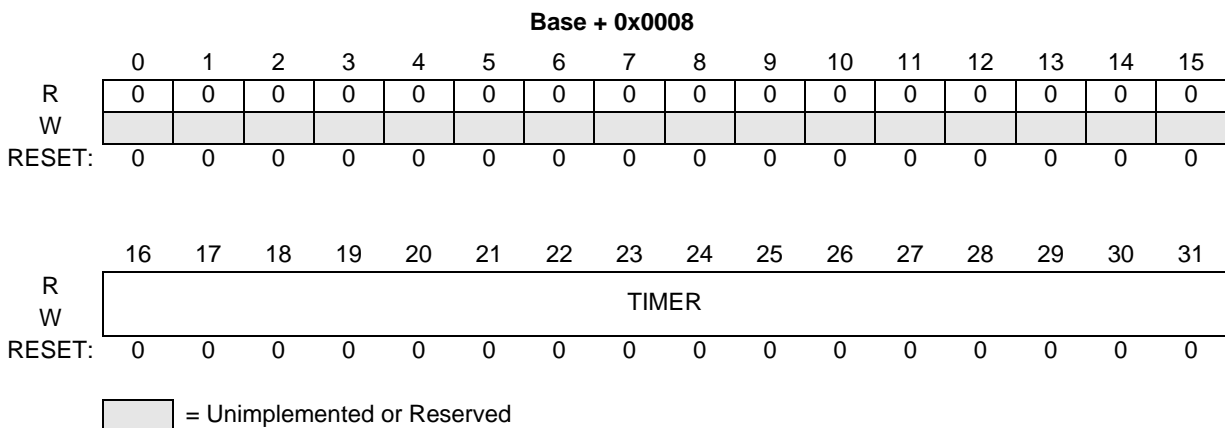

Figure 24-7. Free Running Timer (FLEXCAN_x_TIMER)

24.3.4.4 Rx Global Mask (FLEXCAN_x_RXGMASK)

This register is provided for legacy support. Setting the MBFEN bit in FLEXCAN_x_MCR causes the FLEXCAN_x_RXGMASK Register to have no effect on the module operation.

FLEXCAN_x_RXGMASK is used as acceptance mask for all Rx MBs, excluding MBs 14–15, which have individual mask registers. When the FEN bit in FLEXCAN_x_MCR is set (FIFO enabled), the FLEXCAN_x_RXGMASK also applies to all elements of the ID filter table, except elements 6–7, which have individual masks.

The contents of this register must be programmed while the module is in Freeze Mode, and must not be modified when the module is transmitting or receiving frames.

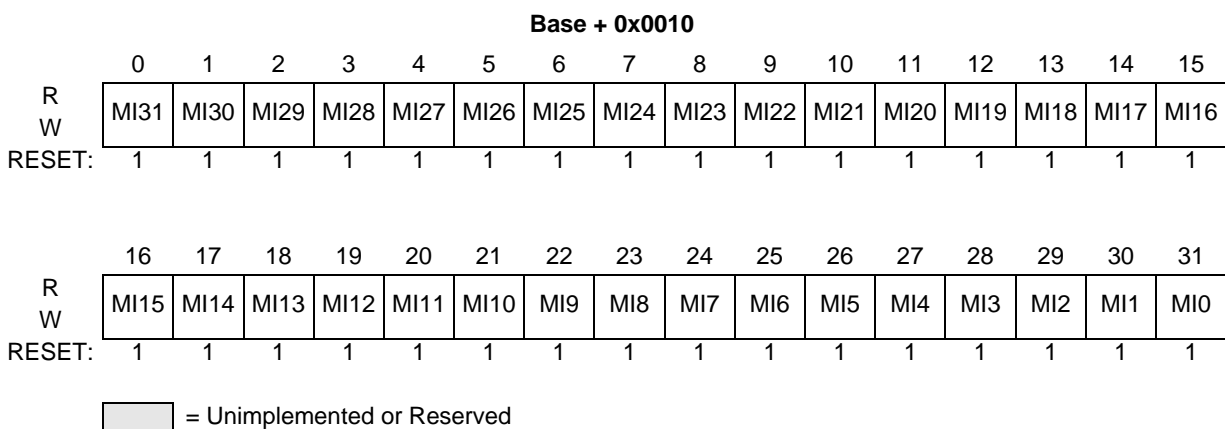

Figure 24-8. Rx Global Mask Register (FLEXCAN_x_RXGMASK)

Table 24-11. FLEXCAN_x_RXGMASK Field Descriptions

| Field | Description |
|------------------|--|
| 0–31 MI31–MI0 | Mask Bits For normal Rx MBs, the mask bits affect the ID filter programmed on the MB. For the Rx FIFO, the mask bits affect all bits programmed in the filter table (ID, IDE, RTR). 0 The corresponding bit in the filter is “don’t care” 1 The corresponding bit in the filter is checked against the one received |

24.3.4.5 Rx 14 Mask (FLEXCAN_x_RX14MASK)

This register is provided for legacy support. Setting the MBFEN bit in FLEXCAN_x_MCR causes the FLEXCAN_x_RX14MASK Register to have no effect on the module operation.

FLEXCAN_x_RX14MASK is used as acceptance mask for the Identifier in Message Buffer 14. When the FEN bit in FLEXCAN_x_MCR is set (FIFO enabled), the RXG14MASK also applies to element 6 of the ID filter table. This register has the same structure as the Rx Global Mask Register. It must be programmed while the module is in Freeze Mode, and must not be modified when the module is transmitting or receiving frames.

- Address Offset: 0x14
- Reset Value: 0xFFFF_FFFF

24.3.4.6 Rx 15 Mask (FLEXCAN_x_RX15MASK)

This register is provided for legacy support. Setting the MBFEN bit in FLEXCAN_x_MCR causes the FLEXCAN_x_RX15MASK Register to have no effect on the module operation.

When the MBFEN bit is negated, FLEXCAN_x_RX15MASK is used as acceptance mask for the Identifier in Message Buffer 15. When the FEN bit in FLEXCAN_x_MCR is set (FIFO enabled), the RXG14MASK also applies to element 7 of the ID filter table. This register has the same structure as the Rx Global Mask Register. It must be programmed while the module is in Freeze Mode, and must not be modified when the module is transmitting or receiving frames.

- Address Offset: 0x18
- Reset Value: 0xFFFF_FFFF

24.3.4.7 Error Counter Register (FLEXCAN_x_ECR)

This register has 2 8-bit fields reflecting the value of two FlexCAN error counters: Transmit Error Counter (Tx_Err_Counter field) and Receive Error Counter (Rx_Err_Counter field). The rules for increasing and decreasing these counters are described in the CAN protocol and are completely implemented in the FlexCAN module. Both counters are read only except in Freeze Mode, where they can be written by the CPU.

Writing to the Error Counter Register while in Freeze Mode is an indirect operation. The data is first written to an auxiliary register and then an internal request/acknowledge procedure across clock domains is executed. All this is transparent to the user, except for the fact that the data will take some time to be actually written to the register. If desired, software can poll the register to discover when the data was actually written.

FlexCAN responds to any bus state as described in the protocol, e.g. transmit 'Error Active' or 'Error Passive' flag, delay its transmission start time ('Error Passive') and avoid any influence on the bus when in 'Bus Off' state. The following are the basic rules for FlexCAN bus state transitions.

- If the value of Tx_Err_Counter or Rx_Err_Counter increases to be greater than or equal to 128, the FLT_CONF field in the Error and Status Register is updated to reflect 'Error Passive' state.
- If the FlexCAN state is 'Error Passive', and either Tx_Err_Counter or Rx_Err_Counter decrements to a value less than or equal to 127 while the other already satisfies this condition, the FLT_CONF field in the Error and Status Register is updated to reflect 'Error Active' state.
- If the value of Tx_Err_Counter increases to be greater than 255, the FLT_CONF field in the Error and Status Register is updated to reflect 'Bus Off' state, and an interrupt may be issued. The value of Tx_Err_Counter is then reset to zero.
- If FlexCAN is in 'Bus Off' state, then Tx_Err_Counter is cascaded together with another internal counter to count the 128th occurrences of 11 consecutive recessive bits on the bus. Hence, Tx_Err_Counter is reset to zero and counts in a manner where the internal counter counts 11 such bits and then wraps around while incrementing the Tx_Err_Counter. When Tx_Err_Counter reaches the value of 128, the FLT_CONF field in the Error and Status Register is updated to be 'Error Active' and both error counters are reset to zero. At any instance of dominant bit following

a stream of less than 11 consecutive recessive bits, the internal counter resets itself to zero without affecting the Tx_Err_Counter value.

- If during system start-up, only one node is operating, then its Tx_Err_Counter increases in each message it is trying to transmit, as a result of acknowledge errors (indicated by the ACK_ERR bit in the Error and Status Register). After the transition to ‘Error Passive’ state, the Tx_Err_Counter does not increment anymore by acknowledge errors. Therefore the device never goes to the ‘Bus Off’ state.
- If the Rx_Err_Counter increases to a value greater than 127, it is not incremented further, even if more errors are detected while being a receiver. At the next successful message reception, the counter is set to a value between 119 and 127 to resume to ‘Error Active’ state.

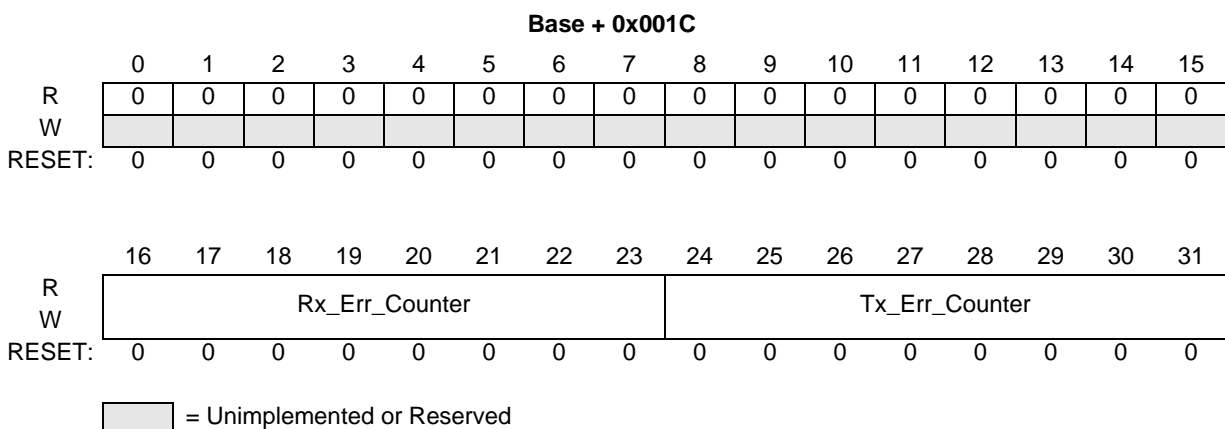

Figure 24-9. Error Counter Register (FLEXCAN_x_ECR)

24.3.4.8 Error and Status Register (FLEXCAN_x_ESR)

This register reflects various error conditions, some general status of the device and it is the source of four interrupts to the CPU. The reported error conditions (bits 16-21) are those that occurred since the last time the CPU read this register. The CPU read action clears bits 16-23. Bits 22-28 are status bits.

Most bits in this register are read only, except TWRN_INT, RWRN_INT, BOFF_INT and ERR_INT, that are interrupt flags that can be cleared by writing '1' to them (writing '0' has no effect). See [Section 24.4.10, Interrupts](#), for more details.

| | | Base + 0x0020 | | | | | | | | | | | | | | | |
|--------|--|---------------|---|---|---|---|---|---|---|---|---|----|----|----|----|----------|----------|
| | | 0 | 1 | 2 | 3 | 4 | 5 | 6 | 7 | 8 | 9 | 10 | 11 | 12 | 13 | 14 | 15 |
| R | | 0 | 0 | 0 | 0 | 0 | 0 | 0 | 0 | 0 | 0 | 0 | 0 | 0 | 0 | TWRN_INT | RWRN_INT |
| W | | | | | | | | | | | | | | | | | |
| RESET: | | 0 | 0 | 0 | 0 | 0 | 0 | 0 | 0 | 0 | 0 | 0 | 0 | 0 | 0 | 0 | 0 |

| | | 16 | 17 | 18 | 19 | 20 | 21 | 22 | 23 | 24 | 25 | 26 | 27 | 28 | 29 | 30 | 31 |
|--------|--|----------|----------|---------|---------|---------|---------|--------|--------|------|------|----------|----|----|----------|---------|----|
| R | | BIT1_ERR | BIT0_ERR | ACK_ERR | CRC_ERR | FRM_ERR | STF_ERR | TX_WRN | RX_WRN | IDLE | TXRX | FLT_CONF | 0 | 0 | BOFF_INT | ERR_INT | 0 |
| W | | | | | | | | | | | | | | | | | |
| RESET: | | 0 | 0 | 0 | 0 | 0 | 0 | 0 | 0 | 0 | 0 | 0 | 0 | 0 | 0 | 0 | 0 |

= Unimplemented or Reserved

Figure 24-10. Error and Status Register

Table 24-12. FLEXCAN_x_ESR Field Descriptions

| Field | Description |
|----------------|--|
| 0–13 | Reserved |
| 14 TWRN_INT | <p>Tx Warning Interrupt Flag</p> <p>If the WRN_EN bit in FLEXCAN_x_MCR is asserted, the TWRN_INT bit is set when the TX_WRN flag transition from '0' to '1', meaning that the Tx error counter reached 96. If the corresponding mask bit in the Control Register (TWRN_MSK) is set, an interrupt is generated to the CPU. This bit is cleared by writing it to '1'. Writing '0' has no effect.</p> <p>0 No such occurrence 1 The Tx error counter transition from < 96 to ≥ 96</p> |
| 15 RWRN_INT | <p>Rx Warning Interrupt Flag</p> <p>If the WRN_EN bit in FLEXCAN_x_MCR is asserted, the RWRN_INT bit is set when the RX_WRN flag transition from '0' to '1', meaning that the Rx error counters reached 96. If the corresponding mask bit in the Control Register (RWRN_MSK) is set, an interrupt is generated to the CPU. This bit is cleared by writing it to '1'. Writing '0' has no effect.</p> <p>0 No such occurrence 1 The Rx error counter transition from < 96 to ≥ 96</p> |
| 16 BIT1_ERR | <p>Bit1 Error</p> <p>This bit indicates when an inconsistency occurs between the transmitted and the received bit in a message.</p> <p>0 No such occurrence 1 At least one bit sent as recessive is received as dominant</p> <p>Note: This bit is not set by a transmitter in case of arbitration field or ACK slot, or in case of a node sending a passive error flag that detects dominant bits.</p> |
| 17 BIT0_ERR | <p>Bit0 Error</p> <p>This bit indicates when an inconsistency occurs between the transmitted and the received bit in a message.</p> <p>0 No such occurrence 1 At least one bit sent as dominant is received as recessive</p> |
| 18 ACK_ERR | <p>Acknowledge Error</p> <p>This bit indicates that an Acknowledge Error has been detected by the transmitter node, i.e., a dominant bit has not been detected during the ACK SLOT.</p> <p>0 No such occurrence 1 An ACK error occurred since last read of this register</p> |
| 19 CRC_ERR | <p>Cyclic Redundancy Check Error</p> <p>This bit indicates that a CRC Error has been detected by the receiver node, i.e., the calculated CRC is different from the received.</p> <p>0 No such occurrence 1 A CRC error occurred since last read of this register.</p> |
| 20 FRM_ERR | <p>Form Error</p> <p>This bit indicates that a Form Error has been detected by the receiver node, i.e., a fixed-form bit field contains at least one illegal bit.</p> <p>0 No such occurrence 1 A Form Error occurred since last read of this register</p> |
| 21 STF_ERR | <p>Stuffing Error</p> <p>This bit indicates that a Stuffing Error has been detected.</p> <p>0 No such occurrence. 1 A Stuffing Error occurred since last read of this register.</p> |
| 22 TX_WRN | <p>TX Error Counter</p> <p>This bit indicates when repetitive errors are occurring during message transmission.</p> <p>0 No such occurrence 1 TX_Err_Counter ≥ 96</p> |

Table 24-12. FLEXCAN_x_ESR Field Descriptions (continued)

| Field | Description |
|-------------------|---|
| 23 RX_WRN | Rx Error Counter This bit indicates when repetitive errors are occurring during message reception. 0 No such occurrence 1 Rx_Err_Counter \geq 96 |
| 24 IDLE | CAN bus IDLE state This bit indicates when CAN bus is in IDLE state. 0 No such occurrence 1 CAN bus is now IDLE |
| 25 TXRX | Current FlexCAN status (transmitting/receiving) This bit indicates if FlexCAN is transmitting or receiving a message when the CAN bus is not in IDLE state. This bit has no meaning when IDLE is asserted. 0 FlexCAN is receiving a message (IDLE=0) 1 FlexCAN is transmitting a message (IDLE=0) |
| 26–27 FLT_CONF | Fault Confinement State This 2-bit field indicates the Confinement State of the FlexCAN module, as shown below. If the LOM bit in the Control Register is asserted, the FLT_CONF field will indicate “Error Passive”. Since the Control Register is not affected by soft reset, the FLT_CONF field will not be affected by soft reset if the LOM bit is asserted. 00 Error Active 01 Error Passive 1X Bus Off |
| 28 | Reserved |
| 29 BOFF_INT | ‘Bus Off’ Interrupt This bit is set when FlexCAN enters ‘Bus Off’ state. If the corresponding mask bit in the Control Register (BOFF_MSK) is set, an interrupt is generated to the CPU. This bit is cleared by writing it to ‘1’. Writing ‘0’ has no effect. 0 No such occurrence 1 FlexCAN module entered ‘Bus Off’ state |
| 30 ERR_INT | Error Interrupt This bit indicates that at least one of the Error Bits (bits 16-21) is set. If the corresponding mask bit in the Control Register (ERR_MSK) is set, an interrupt is generated to the CPU. This bit is cleared by writing it to ‘1’. Writing ‘0’ has no effect. 0 No such occurrence 1 Indicates setting of any Error Bit in the Error and Status Register |
| 31 | Reserved |

24.3.4.9 Interrupt Masks 2 Register (FLEXCAN_x_IMASK2)

This register allows any number of a range of 32 Message Buffer Interrupts to be enabled or disabled. It contains one interrupt mask bit per buffer, enabling the CPU to determine which buffer generates an interrupt after a successful transmission or reception (i.e. when the corresponding FLEXCAN_x_IFLAG2 bit is set).

Base + 0x0024

| | | | | | | | | | | | | | | | | |
|--------|-----|-----|-----|-----|-----|-----|-----|-----|-----|-----|-----|-----|-----|-----|-----|-----|
| | 0 | 1 | 2 | 3 | 4 | 5 | 6 | 7 | 8 | 9 | 10 | 11 | 12 | 13 | 14 | 15 |
| R | BUF | BUF | BUF | BUF | BUF | BUF | BUF | BUF | BUF | BUF | BUF | BUF | BUF | BUF | BUF | BUF |
| W | 63M | 62M | 61M | 60M | 59M | 58M | 57M | 56M | 55M | 54M | 53M | 52M | 51M | 50M | 49M | 48M |
| RESET: | 0 | 0 | 0 | 0 | 0 | 0 | 0 | 0 | 0 | 0 | 0 | 0 | 0 | 0 | 0 | 0 |
| | 16 | 17 | 18 | 19 | 20 | 21 | 22 | 23 | 24 | 25 | 26 | 27 | 28 | 29 | 30 | 31 |
| R | BUF | BUF | BUF | BUF | BUF | BUF | BUF | BUF | BUF | BUF | BUF | BUF | BUF | BUF | BUF | BUF |
| W | 47M | 46M | 45M | 44M | 43M | 42M | 41M | 40M | 39M | 38M | 37M | 36M | 35M | 34M | 33M | 32M |
| RESET: | 0 | 0 | 0 | 0 | 0 | 0 | 0 | 0 | 0 | 0 | 0 | 0 | 0 | 0 | 0 | 0 |

Figure 24-11. Interrupt Masks 2 Register (FLEXCAN_x_IMASK2)

Table 24-13. FLEXCAN_x_IMASK2 Field Descriptions

| Field | Description |
|-------------------------------|--|
| 0–31 BUF63M –BUF32 M | <p>Buffer MB_i Mask</p> <p>Each bit enables or disables the respective FlexCAN Message Buffer (MB32 to MB63) Interrupt.</p> <p>0 The corresponding buffer Interrupt is disabled</p> <p>1 The corresponding buffer Interrupt is enabled</p> <p>Note: Setting or clearing a bit in the FLEXCAN_x_IMASK2 Register can assert or negate an interrupt request, if the corresponding FLEXCAN_x_IFLAG2 bit is set.</p> |

24.3.4.10 Interrupt Masks 1 Register (FLEXCAN_x_IMASK1)

This register allows to enable or disable any number of a range of 32 Message Buffer Interrupts. It contains one interrupt mask bit per buffer, enabling the CPU to determine which buffer generates an interrupt after a successful transmission or reception (i.e., when the corresponding FLEXCAN_x_IFLAG1 bit is set).

Base + 0x0028

| | | | | | | | | | | | | | | | | |
|--------|-----|-----|-----|-----|-----|-----|-----|-----|-----|-----|-----|-----|-----|-----|-----|-----|
| | 0 | 1 | 2 | 3 | 4 | 5 | 6 | 7 | 8 | 9 | 10 | 11 | 12 | 13 | 14 | 15 |
| R | BUF | BUF | BUF | BUF | BUF | BUF | BUF | BUF | BUF | BUF | BUF | BUF | BUF | BUF | BUF | BUF |
| W | 31M | 30M | 29M | 28M | 27M | 26M | 25M | 24M | 23M | 22M | 21M | 20M | 19M | 18M | 17M | 16M |
| RESET: | 0 | 0 | 0 | 0 | 0 | 0 | 0 | 0 | 0 | 0 | 0 | 0 | 0 | 0 | 0 | 0 |
| | 16 | 17 | 18 | 19 | 20 | 21 | 22 | 23 | 24 | 25 | 26 | 27 | 28 | 29 | 30 | 31 |
| R | BUF | BUF | BUF | BUF | BUF | BUF | BUF | BUF | BUF | BUF | BUF | BUF | BUF | BUF | BUF | BUF |
| W | 15M | 14M | 13M | 12M | 11M | 10M | 9M | 8M | 7M | 6M | 5M | 4M | 3M | 2M | 1M | 0M |
| RESET: | 0 | 0 | 0 | 0 | 0 | 0 | 0 | 0 | 0 | 0 | 0 | 0 | 0 | 0 | 0 | 0 |

Figure 24-12. Interrupt Masks 1 Register (FLEXCAN_x_IMASK1)

Table 24-14. FLEXCAN_x_IMASK1 Field Descriptions

| Field | Description |
|--------------------------|---|
| 0–31 BUF31M –BUF0M | Buffer MB _i Mask Each bit enables or disables the respective FlexCAN Message Buffer (MB0 to MB31) Interrupt. 0 The corresponding buffer Interrupt is disabled 1 The corresponding buffer Interrupt is enabled Note: Setting or clearing a bit in the FLEXCAN_x_IMASK1 Register can assert or negate an interrupt request, if the corresponding FLEXCAN_x_IFLAG1 bit is set. |

24.3.4.11 Interrupt Flags 2 Register (FLEXCAN_x_IFLAG2)

This register defines the flags for 32 Message Buffer interrupts. It contains one interrupt flag bit per buffer. Each successful transmission or reception sets the corresponding FLEXCAN_x_IFLAG2 bit. If the corresponding FLEXCAN_x_IMASK2 bit is set, an interrupt will be generated. The interrupt flag must be cleared by writing it to '1'. Writing '0' has no effect.

When the AEN bit in the FLEXCAN_x_MCR is set (Abort enabled), while the FLEXCAN_x_IFLAG2 bit is set for a MB configured as Tx, the writing access done by CPU into the corresponding MB will be blocked.

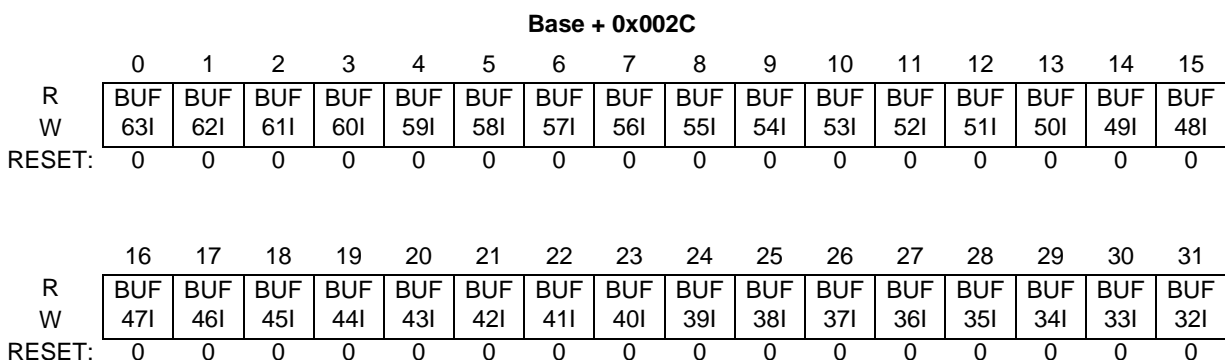
Figure 24-13. Interrupt Flags 2 Register (FLEXCAN_x_IFLAG2)
Table 24-15. FLEXCAN_x_IFLAG2 Field Descriptions

| Field | Description |
|---------------------------|---|
| 0–31 BUF32I– BUF63I | Buffer MB _i Interrupt Each bit flags the respective FlexCAN Message Buffer (MB32 to MB63) interrupt. 0 No such occurrence 1 The corresponding buffer has successfully completed transmission or reception |

24.3.4.12 Interrupt Flags 1 Register (FLEXCAN_x_IFLAG1)

This register defines the flags for 32 Message Buffer interrupts and FIFO interrupts. It contains one interrupt flag bit per buffer. Each successful transmission or reception sets the corresponding FLEXCAN_x_IFLAG1 bit. If the corresponding FLEXCAN_x_IMASK1 bit is set, an interrupt will be generated. The Interrupt flag must be cleared by writing it to '1'. Writing '0' has no effect.

When the AEN bit in the FLEXCAN_x_MCR is set (Abort enabled), while the FLEXCAN_x_IFLAG1 bit is set for a MB configured as Tx, the writing access done by CPU into the corresponding MB will be blocked.

When the FEN bit in the FLEXCAN_x_MCR is set (FIFO enabled), the function of the 8 least significant interrupt flags (BUF7I - BUF0I) is changed to support the FIFO operation. BUF7I, BUF6I and BUF5I indicate operating conditions of the FIFO, while BUF4I to BUF0I are not used.

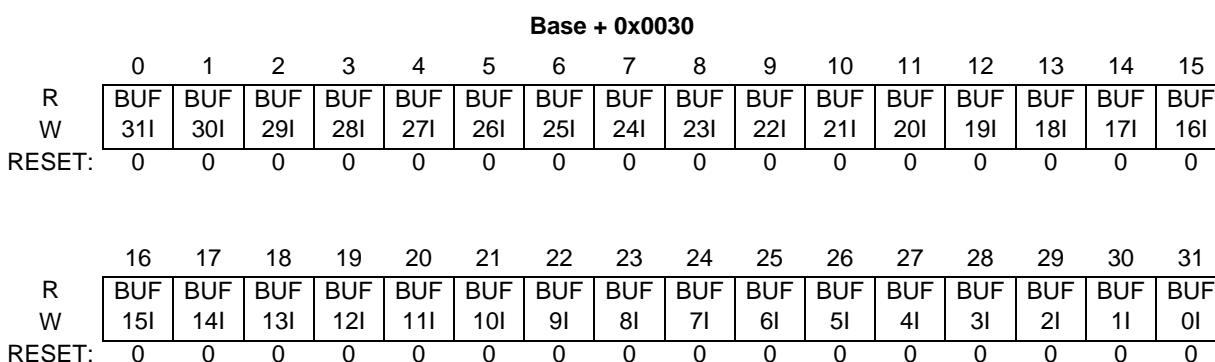

Figure 24-14. Interrupt Flags 1 Register (FLEXCAN_x_IFLAG1)

Table 24-16. FLEXCAN_x_IFLAG1 Field Descriptions

| Field | Description |
|--------------------------|--|
| 0–23 BUF31I– BUF8I | Buffer MB _i Interrupt Each bit flags the respective FlexCAN Message Buffer (MB8 to MB31) interrupt. 0 No such occurrence 1 The corresponding MB has successfully completed transmission or reception |

Table 24-16. FLEXCAN_x_IFLAG1 Field Descriptions (continued)

| Field | Description |
|--------------------------|--|
| 24 BUF7I | Buffer MB7 Interrupt or “FIFO Overflow” If the FIFO is not enabled, this bit flags the interrupt for MB7. If the FIFO is enabled, this flag indicates an overflow condition in the FIFO (frame lost because FIFO is full). 0 No such occurrence 1 MB7 completed transmission/reception or FIFO overflow |
| 25 BUF6I | Buffer MB6 Interrupt or “FIFO Warning” If the FIFO is not enabled, this bit flags the interrupt for MB6. If the FIFO is enabled, this flag indicates that 5 out of 6 buffers of the FIFO are already occupied (FIFO almost full). 0 No such occurrence 1 MB6 completed transmission/reception or FIFO almost full |
| 26 BUF5I | Buffer MB5 Interrupt or “Frames available in FIFO” If the FIFO is not enabled, this bit flags the interrupt for MB5. If the FIFO is enabled, this flag indicates that at least one frame is available to be read from the FIFO. 0 No such occurrence 1 MB5 completed transmission/reception or frames available in the FIFO |
| 27–31 BUF4I–B UF0I | Buffer MB _i Interrupt or “reserved” If the FIFO is not enabled, these bits flag the interrupts for MB0 to MB4. If the FIFO is enabled, these flags are not used and must be considered as reserved locations. 0 No such occurrence 1 Corresponding MB completed transmission/reception |

24.3.4.13 Rx Individual Mask Registers (RXIMR0–RXIMR63)

These registers are used as acceptance masks for ID filtering in Rx MBs and the FIFO. If the FIFO is not enabled, one mask register is provided for each available Message Buffer, providing ID masking capability on a per Message Buffer basis. When the FIFO is enabled (FEN bit in FLEXCAN_x_MCR is set), the first 8 Mask Registers apply to the 8 elements of the FIFO filter table (on a one-to-one correspondence), while the rest of the registers apply to the regular MBs, starting from MB8.

The Individual Rx Mask Registers are implemented in RAM, so they are not affected by reset and must be explicitly initialized prior to any reception. Furthermore, they can only be accessed by the CPU while the module is in Freeze Mode. Out of Freeze Mode, write accesses are blocked and read accesses will return “all zeros”. Furthermore, if the MBFEN bit in the FLEXCAN_x_MCR Register is negated, any read or write operation to these registers results in access error.



Figure 24-15. Rx Individual Mask Registers (RXIMR0 - RXIMR63)

Table 24-17. RXIMR0 — RXIMR63 Field Descriptions

| Field | Description |
|------------------|---|
| 0–31 MI31–MI0 | Mask Bits For normal Rx MBs, the mask bits affect the ID filter programmed on the MB. For the Rx FIFO, the mask bits affect all bits programmed in the filter table (ID, IDE, RTR). 0 The corresponding bit in the filter is “don’t care” 1 The corresponding bit in the filter is checked against the one received\ |

24.4 Functional Description

24.4.1 Overview

The FlexCAN module is a CAN protocol engine with a very flexible mailbox system for transmitting and receiving CAN frames. The mailbox system is composed by a set of 64 Message Buffers (MB) that store configuration and control data, time stamp, message ID and data (see [Section 24.3.2, Message Buffer Structure](#)). The memory corresponding to the first 8 MBs can be configured to support a FIFO reception scheme with a powerful ID filtering mechanism, capable of checking incoming frames against a table of IDs (up to 8 extended IDs or 16 standard IDs or 32 8-bit ID slices), each one with its own individual mask register. Simultaneous reception through FIFO and mailbox is supported. For mailbox reception, a matching algorithm makes it possible to store received frames only into MBs that have the same ID programmed on its ID field. A masking scheme makes it possible to match the ID programmed on the MB with a range of IDs on received CAN frames. For transmission, an arbitration algorithm decides the

prioritization of MBs to be transmitted based on the message ID (optionally augmented by 3 local priority bits) or the MB ordering.

Before proceeding with the functional description, an important concept must be explained. A Message Buffer is said to be “active” at a given time if it can participate in the matching and arbitration algorithms that are happening at that time. An Rx MB with a ‘0000’ code is inactive (refer to [Table 24-5](#)). Similarly, a Tx MB with a ‘1000’ or ‘1001’ code is also inactive (refer to [Table 24-6](#)). An MB not programmed with ‘0000’, ‘1000’ or ‘1001’ will be temporarily deactivated (will not participate in the current arbitration or matching run) when the CPU writes to the C/S field of that MB (see [Section 24.4.6.2, Message Buffer Deactivation](#)).

24.4.2 Transmit Process

In order to transmit a CAN frame, the CPU must prepare a Message Buffer for transmission by executing the following procedure:

- If the MB is active (transmission pending), write ‘1000’ to the Code field to deactivate the MB. The deactivated MB can transmit without setting IFLAG and without updating the CODE field (see [Section 24.4.6.2, Message Buffer Deactivation](#)).
- Write the ID word.
- Write the data bytes.
- Write the Length, Control and Code fields of the Control and Status word to activate the MB.

Once the MB is activated in the fourth step, it will participate into the arbitration process and eventually be transmitted according to its priority. At the end of the successful transmission, the value of the Free Running Timer is written into the Time Stamp field, the Code field in the Control and Status word is updated, a status flag is set in the Interrupt Flag Register and an interrupt is generated if allowed by the corresponding Interrupt Mask Register bit. The new Code field after transmission depends on the code that was used to activate the MB in step four (see [Table 24-5](#) and [Table 24-6](#) in [Section 24.3.2, Message Buffer Structure](#)). When the Abort feature is enabled (AEN in FLEXCAN_x_MCR is asserted), after the Interrupt Flag is asserted for a MB configured as transmit buffer, the MB is blocked, therefore the CPU is not able to update it until the Interrupt Flag be negated by CPU. It means that the CPU must clear the corresponding IFLAG before starting to prepare this MB for a new transmission or reception.

24.4.3 Arbitration process

The arbitration process is an algorithm executed by the MBM that scans the whole MB memory looking for the highest priority message to be transmitted. All MBs programmed as transmit buffers will be scanned to find the lowest ID¹ or the lowest MB number or the highest priority, depending on the LBUF and LPRIO_EN bits on the Control Register. The arbitration process is triggered in the following events:

- During the CRC field of the CAN frame
- During the error delimiter field of the CAN frame

1. Actually, if LBUF is negated, the arbitration considers not only the ID, but also the RTR and IDE bits placed inside the ID at the same positions they are transmitted in the CAN frame.

- During Intermission, if the winner MB defined in a previous arbitration was deactivated, or if there was no MB to transmit, but the CPU wrote to the C/S word of any MB after the previous arbitration finished
- When MBM is in Idle or Bus Off state and the CPU writes to the C/S word of any MB
- Upon leaving Freeze Mode

When LBUF is asserted, the LPRIO_EN bit has no effect and the lowest number buffer is transmitted first. When LBUF and LPRIO_EN are both negated, the MB with the lowest ID is transmitted first but. If LBUF is negated and LPRIO_EN is asserted, the PRIO bits augment the ID used during the arbitration process. With this extended ID concept, arbitration is done based on the full 32-bit ID and the PRIO bits define which MB should be transmitted first, therefore MBs with PRIO = 000 have higher priority. If two or more MBs have the same priority, the regular ID will determine the priority of transmission. If two or more MBs have the same priority (3 extra bits) and the same regular ID, the lowest MB will be transmitted first.

Once the highest priority MB is selected, it is transferred to a temporary storage space called Serial Message Buffer (SMB), which has the same structure as a normal MB but is not user accessible. This operation is called “move-out” and after it is done, write access to the corresponding MB is blocked (if the AEN bit in FLEXCAN_x_MCR is asserted). The write access is released in the following events:

- After the MB is transmitted
- FlexCAN enters in HALT or BUS OFF
- FlexCAN loses the bus arbitration or there is an error during the transmission

At the first opportunity window on the CAN bus, the message on the SMB is transmitted according to the CAN protocol rules. FlexCAN transmits up to eight data bytes, even if the DLC (Data Length Code) value is bigger.

24.4.4 Receive Process

To be able to receive CAN frames into the mailbox MBs, the CPU must prepare one or more Message Buffers for reception by executing the following steps:

- If the MB has a pending transmission, write an ABORT code (‘1001’) to the Code field of the Control and Status word to request an abortion of the transmission, then read back the Code field and the IFLAG register to check if the transmission was aborted (see [Section 24.4.6.1, Transmission Abort Mechanism](#)). If backwards compatibility is desired (AEN in FLEXCAN_x_MCR negated), just write ‘1000’ to the Code field to inactivate the MB, but then the pending frame may be transmitted without notification (see [Section 24.4.6.2, Message Buffer Deactivation](#)). If the MB already programmed as a receiver, just write ‘0000’ to the Code field of the Control and Status word to keep the MB inactive.
- Write the ID word
- Write ‘0100’ to the Code field of the Control and Status word to activate the MB

Once the MB is activated in the third step, it will be able to receive frames that match the programmed ID. At the end of a successful reception, the MB is updated by the MBM as follows:

- The value of the Free Running Timer is written into the Time Stamp field
- The received ID, Data (8 bytes at most) and Length fields are stored
- The Code field in the Control and Status word is updated (see [Table 24-5](#) and [Table 24-6](#) in [Section 24.3.2, Message Buffer Structure](#))
- A status flag is set in the Interrupt Flag Register and an interrupt is generated if allowed by the corresponding Interrupt Mask Register bit

Upon receiving the MB interrupt, the CPU should service the received frame using the following procedure:

- Read the Control and Status word (mandatory – activates an internal lock for this buffer)
- Read the ID field (optional – needed only if a mask was used)
- Read the Data field
- Read the Free Running Timer (optional – releases the internal lock)

Upon reading the Control and Status word, if the BUSY bit is set in the Code field, then the CPU should defer the access to the MB until this bit is negated. Reading the Free Running Timer is not mandatory. If not executed the MB remains locked, unless the CPU reads the C/S word of another MB. Note that only a single MB is locked at a time. The only mandatory CPU read operation is the one on the Control and Status word to assure data coherency (see [Section 24.4.6, Data Coherence](#)).

The CPU should synchronize to frame reception by the status flag bit for the specific MB in one of the IFLAG Registers and not by the Code field of that MB. Polling the Code field does not work because once a frame was received and the CPU services the MB (by reading the C/S word followed by unlocking the MB), the Code field will not return to EMPTY. It will remain FULL, as explained in [Table 24-5](#). If the CPU tries to workaround this behavior by writing to the C/S word to force an EMPTY code after reading the MB, the MB is actually deactivated from any currently ongoing matching process. As a result, a newly received frame matching the ID of that MB may be lost. In summary: *never do polling by reading directly the C/S word of the MBs. Instead, read the IFLAG registers.*

Note that the received ID field is always stored in the matching MB, thus the contents of the ID field in an MB may change if the match was due to masking. Note also that FlexCAN does receive frames transmitted by itself if there exists an Rx matching MB, provided the SRX_DIS bit in the FLEXCAN_x_MCR is not asserted. If SRX_DIS is asserted, FlexCAN will not store frames transmitted by itself in any MB, even if it contains a matching MB, and no interrupt flag or interrupt signal will be generated due to the frame reception.

To be able to receive CAN frames through the FIFO, the CPU must enable and configure the FIFO during Freeze Mode (see [Section 24.4.7, Rx FIFO](#)). Upon receiving the frames available interrupt from FIFO, the CPU should service the received frame using the following procedure:

- Read the Control and Status word (optional – needed only if a mask was used for IDE and RTR bits)
- Read the ID field (optional – needed only if a mask was used)
- Read the Data field

- Clear the frames available interrupt (mandatory – release the buffer and allow the CPU to read the next FIFO entry)

24.4.5 Matching Process

The matching process is an algorithm executed by the MBM that scans the MB memory looking for Rx MBs programmed with the same ID as the one received from the CAN bus. If the FIFO is enabled, the 8-entry ID table from FIFO is scanned first and then, if a match is not found within the FIFO table, the other MBs are scanned. In the event that the FIFO is full, the matching algorithm will always look for a matching MB outside the FIFO region.

When the frame is received, it is temporarily stored in a hidden auxiliary MB called Serial Message Buffer (SMB). The matching process takes place during the CRC field of the received frame. If a matching ID is found in the FIFO table or in one of the regular MBs, the contents of the SMB will be transferred to the FIFO or to the matched MB during the 6th bit of the End-Of-Frame field of the CAN protocol. This operation is called “move-in”. If any protocol error (CRC, ACK, etc.) is detected, than the move-in operation does not happen.

For the regular mailbox MBs, an MB is said to be “free to receive” a new frame if the following conditions are satisfied:

- The MB is not locked (see [Section 24.4.6.3, Message Buffer Lock Mechanism](#))
- The Code field is either EMPTY or else it is FULL or OVERRUN but the CPU has already serviced the MB (read the C/S word and then unlocked the MB)

If the first MB with a matching ID is not “free to receive” the new frame, then the matching algorithm keeps looking for another free MB until it finds one. If it can not find one that is free, then it will overwrite the last matching MB (unless it is locked) and set the Code field to OVERRUN (refer to [Table 24-5](#) and [Table 24-6](#)). If the last matching MB is locked, then the new message remains in the SMB, waiting for the MB to be unlocked (see [Section 24.4.6.3, Message Buffer Lock Mechanism](#)).

Suppose, for example, that the FIFO is disabled and there are two MBs with the same ID, and FlexCAN starts receiving messages with that ID. Let us say that these MBs are the second and the fifth in the array. When the first message arrives, the matching algorithm will find the first match in MB number 2. The code of this MB is EMPTY, so the message is stored there. When the second message arrives, the matching algorithm will find MB number 2 again, but it is not “free to receive,” so it will keep looking and find MB number 5 and store the message there. If yet another message with the same ID arrives, the matching algorithm finds out that there are no matching MBs that are “free to receive,” so it decides to overwrite the last matched MB, which is number 5. In doing so, it sets the Code field of the MB to indicate OVERRUN.

The ability to match the same ID in more than one MB can be exploited to implement a reception queue (in addition to the full featured FIFO) to allow more time for the CPU to service the MBs. By programming more than one MB with the same ID, received messages will be queued into the MBs. The CPU can examine the Time Stamp field of the MBs to determine the order in which the messages arrived.

The matching algorithm described above can be changed to be the same one used in previous versions of the FlexCAN module. When the MBFEN bit in FLEXCAN_x_MCR is negated, the matching algorithm

stops at the first MB with a matching ID that it finds, whether this MB is free or not. As a result, the message queuing feature does not work if the MBFEN bit is negated.

Matching to a range of IDs is possible by using ID Acceptance Masks. FlexCAN supports individual masking per MB. Please refer to [Section 24.3.4.13, Rx Individual Mask Registers \(RXIMR0–RXIMR63\)](#). During the matching algorithm, if a mask bit is asserted, then the corresponding ID bit is compared. If the mask bit is negated, the corresponding ID bit is “don’t care”. Please note that the Individual Mask Registers are implemented in RAM, so they are not initialized out of reset. Also, they can only be programmed if the MBFEN bit is asserted and while the module is in Freeze Mode.

FlexCAN also supports an alternate masking scheme with only three mask registers (RGXMASK, FLEXCAN_x_RX14MASK and FLEXCAN_x_RX15MASK) for backwards compatibility. This alternate masking scheme is enabled when the MBFEN bit in the FLEXCAN_x_MCR Register is negated.

24.4.6 Data Coherence

In order to maintain data coherency and FlexCAN proper operation, the CPU must obey the rules described in [Section 24.4.2, Transmit Process](#) and [Section 24.4.4, Receive Process](#). Any form of CPU accessing an MB structure within FlexCAN other than those specified may cause FlexCAN to behave in an unpredictable way.

24.4.6.1 Transmission Abort Mechanism

The abort mechanism provides a safe way to request the abortion of a pending transmission. A feedback mechanism is provided to inform the CPU if the transmission was aborted or if the frame could not be aborted and was transmitted instead. In order to maintain backwards compatibility, the abort mechanism must be explicitly enabled by asserting the AEN bit in the FLEXCAN_x_MCR.

In order to abort a transmission, the CPU must write a specific abort code (1001) to the Code field of the Control and Status word. When the abort mechanism is enabled, the active MBs configured as transmission must be aborted first and then they may be updated. If the abort code is written to an MB that is currently being transmitted, or to an MB that was already loaded into the SMB for transmission, the write operation is blocked and the MB is not deactivated, but the abort request is captured and kept pending until one of the following conditions are satisfied:

- The module loses the bus arbitration
- There is an error during the transmission
- The module is put into Freeze Mode

If none of conditions above are reached, the MB is transmitted correctly, the interrupt flag is set in the IFLAG register and an interrupt to the CPU is generated (if enabled). The abort request is automatically cleared when the interrupt flag is set. In the other hand, if one of the above conditions is reached, the frame is not transmitted, therefore the abort code is written into the Code field, the interrupt flag is set in the IFLAG and an interrupt is (optionally) generated to the CPU.

If the CPU writes the abort code before the transmission begins internally, then the write operation is not blocked, therefore the MB is updated and no interrupt flag is set. In this way the CPU just needs to read the abort code to make sure the active MB was deactivated. Although the AEN bit is asserted and the CPU

wrote the abort code, in this case the MB is deactivated and not aborted, because the transmission did not start yet. One MB is only aborted when the abort request is captured and kept pending until one of the previous conditions are satisfied.

The abort procedure can be summarized as follows:

- CPU writes 1001 into the code field of the C/S word
- CPU reads the CODE field and compares it to the value that was written
- If the CODE field that was read is different from the value that was written, the CPU must read the corresponding IFLAG to check if the frame was transmitted or it is being currently transmitted. If the corresponding IFLAG is set, the frame was transmitted. If the corresponding IFLAG is reset, the CPU must wait for it to be set, and then the CPU must read the CODE field to check if the MB was aborted (CODE=1001) or it was transmitted (CODE=1000).

NOTE

An abort request to a TxMB can block any write operation into its CODE field. Therefore, the TxMB cannot be aborted or deactivated until it completes a transmission by winning the CAN bus arbitration.

24.4.6.2 Message Buffer Deactivation

Deactivation is mechanism provided to maintain data coherence when the CPU writes to the Control and Status word of active MBs out of Freeze Mode. Any CPU write access to the Control and Status word of an MB causes that MB to be excluded from the transmit or receive processes during the current matching or arbitration round. The deactivation is temporary, affecting only for the current match/arbitration round.

The purpose of deactivation is data coherency. The match/arbitration process scans the MBs to decide which MB to transmit or receive. If the CPU updates the MB in the middle of a match or arbitration process, the data of that MB may no longer be coherent, therefore deactivation of that MB is done.

Even with the coherence mechanism described above, writing to the Control and Status word of active MBs when not in Freeze Mode may produce undesirable results. Examples are:

- Matching and arbitration are one-pass processes. If MBs are deactivated after they are scanned, no re-evaluation is done to determine a new match/winner. If an Rx MB with a matching ID is deactivated during the matching process after it was scanned, then this MB is marked as invalid to receive the frame, and FlexCAN will keep looking for another matching MB within the ones it has not scanned yet. If it can not find one, then the message will be lost. Suppose, for example, that two MBs have a matching ID to a received frame, and the user deactivated the first matching MB after FlexCAN has scanned the second. The received frame will be lost even if the second matching MB was “free to receive”.
- If a Tx MB containing the lowest ID is deactivated after FlexCAN has scanned it, then FlexCAN will look for another winner within the MBs that it has not scanned yet. Therefore, it may transmit an MB with ID that may not be the lowest at the time because a lower ID might be present in one of the MBs that it had already scanned before the deactivation.
- There is a point in time until which the deactivation of a Tx MB causes it not to be transmitted (end of move-out). After this point, it is transmitted but no interrupt is issued and the Code field is not

updated. In order to avoid this situation, the abort procedures described in [Section 24.4.6.1, Transmission Abort Mechanism](#), should be used.

24.4.6.3 Message Buffer Lock Mechanism

Besides MB deactivation, FlexCAN has another data coherence mechanism for the receive process. When the CPU reads the Control and Status word of an “active not empty” Rx MB, FlexCAN assumes that the CPU wants to read the whole MB in an atomic operation, and thus it sets an internal lock flag for that MB. The lock is released when the CPU reads the Free Running Timer (global unlock operation), or when it reads the Control and Status word of another MB. The MB locking is done to prevent a new frame to be written into the MB while the CPU is reading it.

NOTE

The locking mechanism only applies to Rx MBs which have a code different than INACTIVE ('0000') or EMPTY¹ ('0100'). Also, Tx MBs can not be locked.

Suppose, for example, that the FIFO is disabled and the second and the fifth MBs of the array are programmed with the same ID, and FlexCAN has already received and stored messages into these two MBs. Suppose now that the CPU decides to read MB number 5 and at the same time another message with the same ID is arriving. When the CPU reads the Control and Status word of MB number 5, this MB is locked. The new message arrives and the matching algorithm finds out that there are no “free to receive” MBs, so it decides to override MB number 5. However, this MB is locked, so the new message can not be written there. It will remain in the SMB waiting for the MB to be unlocked, and only then will be written to the MB. If the MB is not unlocked in time and yet another new message with the same ID arrives, then the new message overwrites the one on the SMB and there will be no indication of lost messages either in the Code field of the MB or in the Error and Status Register.

While the message is being moved-in from the SMB to the MB, the BUSY bit on the Code field is asserted. If the CPU reads the Control and Status word and finds out that the BUSY bit is set, it should defer accessing the MB until the BUSY bit is negated.

NOTE

If the BUSY bit is asserted or if the MB is empty, then reading the Control and Status word does not lock the MB.

Deactivation takes precedence over locking. If the CPU deactivates a locked Rx MB, then its lock status is negated and the MB is marked as invalid for the current matching round. Any pending message on the SMB will not be transferred anymore to the MB.

24.4.7 Rx FIFO

The receive-only FIFO is enabled by asserting the FEN bit in the FLEXCAN_x_MCR. The reset value of this bit is zero to maintain software backwards compatibility with previous versions of the module that did not have the FIFO feature. When the FIFO is enabled, the memory region normally occupied by the first

1. In previous FlexCAN versions, reading the C/S word locked the MB even if it was EMPTY. This behavior will be honoured when the MBFEN bit is negated.

8 MBs (0x80-0xFF) is now reserved for use of the FIFO engine (see [Section 24.3.3, Rx FIFO Structure](#)). Management of read and write pointers is done internally by the FIFO engine. The CPU can read the received frames sequentially, in the order they were received, by repeatedly accessing a Message Buffer structure at the beginning of the memory.

The FIFO can store up to 6 frames pending service by the CPU. An interrupt is sent to the CPU when new frames are available in the FIFO. Upon receiving the interrupt, the CPU must read the frame (accessing an MB in the 0x80 address) and then clear the interrupt. The act of clearing the interrupt triggers the FIFO engine to replace the MB in 0x80 with the next frame in the queue, and then issue another interrupt to the CPU. If the FIFO is full and more frames continue to be received, an OVERFLOW interrupt is issued to the CPU and subsequent frames are not accepted until the CPU creates space in the FIFO by reading one or more frames. A warning interrupt is also generated when 5 frames are accumulated in the FIFO.

A powerful filtering scheme is provided to accept only frames intended for the target application, thus reducing the interrupt servicing work load. The filtering criteria is specified by programming a table of 8 32-bit registers that can be configured to one of the following formats (see also [Section 24.3.3, Rx FIFO Structure](#)):

- Format A: 8 extended or standard IDs (including IDE and RTR)
- Format B: 16 standard IDs or 16 extended 14-bit ID slices (including IDE and RTR)
- Format C: 32 standard or extended 8-bit ID slices

NOTE

A chosen format is applied to all 8 registers of the filter table. It is not possible to mix formats within the table.

The eight elements of the filter table are individually affected by the first eight Individual Mask Registers (RXIMR0 - RXIMR7), allowing very powerful filtering criteria to be defined. The rest of the RXIMR, starting from RXIM8, continue to affect the regular MBs, starting from MB8. If the MBFEN bit is negated (or if the RXIMR are not available for the particular MCU), then the FIFO filter table is affected by the legacy mask registers as follows: element 6 is affected by FLEXCAN_x_RX14MASK, element 7 is affected by FLEXCAN_x_RX15MASK and the other elements (0 to 5) are affected by FLEXCAN_x_RXGMASK.

24.4.7.1 Precautions when using Global Mask and Individual Mask registers

Mask filtering alignment is affected based on the setting of the FEN and BCC of MCR. [Table 24-18](#) table shows recommended actions depending on FEN and BCC settings.

Table 24-18. Recommended FEN and BCC settings

| Case | MCR[FEN] RxFIFO | MCR[BCC] Rx Individual Mask | Notes |
|--------|--------------------|--------------------------------|--|
| Case 1 | FEN = 0 | BCC = 0 | RXGMASK, RX14MASK, and RX15MASK can safely be used. This allows backwards compatibility to older devices (e.g., devices without the individual masks feature). In this case, individual masks are not used. |
| Case 2 | FEN = 1 | BCC = 0 | 1st alternative: Do not use RXGMASK, RX14MASK, and RX15MASK in this case, leave the masks in their reset state. |
| Case 3 | FEN = 1 | BCC = 0 | 2nd alternative: Do not configure any MB as Rx (i.e., let all MBs as either Tx or inactive). In this case, RXGMASK, RX14MASK, and RX15MASK can be used to affect ID Tables without affecting the filtering process for Rx MBs. |
| Case 4 | Don't care | BCC = 1 | If MCR[BCC] = 1, then the RXIMRs are enabled. Thus, RXGMASK, RX14MASK, and RX15MASK are not used. Particularly, when MCR[FEN] = 0, RxFIFO is disabled; RXGMASK, RX14MASK, and RX15MASK do not affect filtering. Individual masks are used. |

24.4.8 CAN protocol Related Features

24.4.8.1 Remote Frames

A remote frame is a special kind of frame. The user can program a MB to be a Request Remote frame by writing the MB as Transmit with the RTR bit set to '1'. After the Remote Request frame is transmitted successfully, the MB becomes a Receive Message Buffer, with the same ID as before.

When a Remote Request frame is received by the FlexCAN module, its ID is compared to the IDs of the transmit message buffers with the Code field '1010'. If there is a matching ID, then this MB frame is transmitted. Note that if the matching MB has the RTR bit set, then the FlexCAN module transmits a Remote Frame as a response.

A received Remote Request frame is not stored in a receive buffer. It is only used to trigger a transmission of a frame in response. The mask registers are not used in remote frame matching, and all ID bits (except RTR) of the incoming received frame should match.

In the case that a Remote Request frame was received and matched an MB, this message buffer immediately enters the internal arbitration process, but is considered as normal Tx MB, with no higher priority. The data length of this frame is independent of the DLC field in the remote frame that initiated its transmission.

24.4.8.2 Overload Frames

FlexCAN does transmit overload frames due to detection of following conditions on CAN bus:

- Detection of a dominant bit in the first/second bit of Intermission

- Detection of a dominant bit at the 7th bit (last) of End of Frame field (Rx frames)
- Detection of a dominant bit at the 8th bit (last) of Error Frame Delimiter or Overload Frame Delimiter

24.4.8.3 Time Stamp

The value of the Free Running Timer is sampled at the beginning of the Identifier field on the CAN bus, and is stored at the end of “move-in” in the TIME STAMP field, providing network behavior with respect to time.

Note that the Free Running Timer can be reset upon a specific frame reception, enabling network time synchronization. Refer to TSYN description in [Section 24.3.4.2, Control Register \(FLEXCAN_x_CTRL\)](#).

24.4.8.4 Protocol Timing

Figure 24-16 shows the structure of the clock generation circuitry that feeds the CAN Protocol Interface (CPI) sub-module. The clock source bit (CLK_SRC) in the FLEXCAN_x_CTRL Register defines whether the internal clock is connected to the output of a crystal oscillator (Oscillator Clock) or to the Peripheral (system) Clock from PLL). In order to guarantee reliable operation, the clock source should be selected while the module is in Disable Mode (bit MDIS set in the Module Configuration Register).

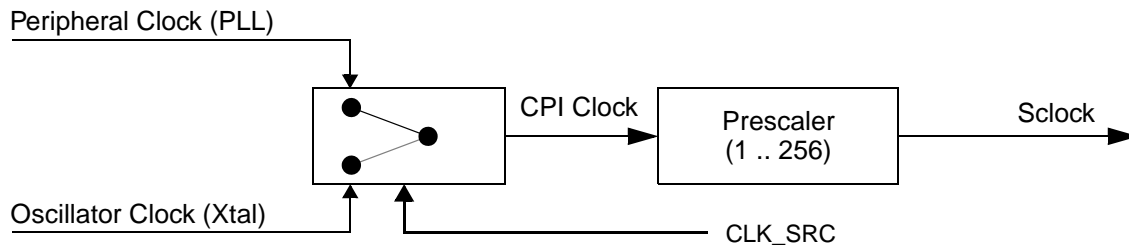

Figure 24-16. CAN Engine Clocking Scheme

The crystal oscillator clock should be selected whenever a tight tolerance (up to 0.1%) is required in the CAN bus timing. The crystal oscillator clock has better jitter performance than PLL generated clocks.

The FlexCAN module supports a variety of means to setup bit timing parameters that are required by the CAN protocol. The Control Register has various fields used to control bit timing parameters: PRESDIV, PROPSEG, PSEG1, PSEG2 and RJW. See [Section 24.3.4.2, Control Register \(FLEXCAN_x_CTRL\)](#).

The PRESDIV field controls a prescaler that generates the Serial Clock (Sclock), whose period defines the ‘time quantum’ used to compose the CAN waveform. A time quantum is the atomic unit of time handled by the CAN engine.

$$f_{Tq} = \frac{f_{CANCLK}}{(Prescaler\ value)}$$

A bit time is subdivided into three segments¹ (reference [Figure 24-17](#) and [Table 24-19](#)):

- SYNC_SEG: This segment has a fixed length of one time quantum. Signal edges are expected to happen within this section
- Time Segment 1: This segment includes the Propagation Segment and the Phase Segment 1 of the CAN standard. It can be programmed by setting the PROPSEG and the PSEG1 fields of the FLEXCAN_x_CTRL Register so that their sum (plus 2) is in the range of 4 to 16 time quanta
- Time Segment 2: This segment represents the Phase Segment 2 of the CAN standard. It can be programmed by setting the PSEG2 field of the FLEXCAN_x_CTRL Register (plus 1) to be 2 to 8 time quanta long

$$\text{Bit Rate} = \frac{f_{Tq}}{(\text{number of Time Quanta})}$$

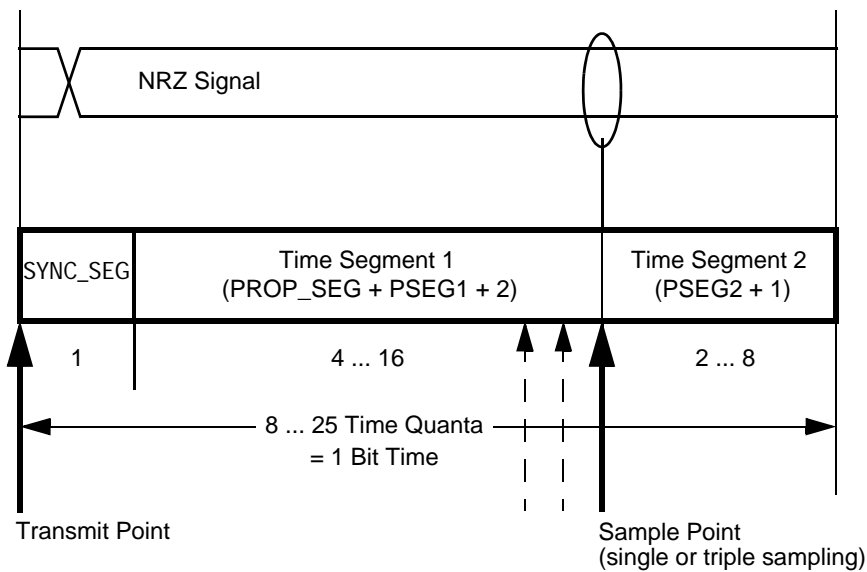

Figure 24-17. Segments within the Bit Time

Table 24-19. Time Segment Syntax

| Syntax | Description |
|----------------|--|
| SYNC_SEG | System expects transitions to occur on the bus during this period. |
| Transmit Point | A node in transmit mode transfers a new value to the CAN bus at this point. |
| Sample Point | A node samples the bus at this point. If the three samples per bit option is selected, then this point marks the position of the third sample. |

Table 24-20 gives an overview of the CAN compliant segment settings and the related parameter values.

1. For further explanation of the underlying concepts please refer to ISO/DIS 11519-1, Section 10.3. Reference also the Bosch CAN 2.0A/B protocol specification dated September 1991 for bit timing.

Table 24-20. CAN Standard Compliant Bit Time Segment Settings

| Time Segment 1 | Time Segment 2 | Re-synchronization Jump Width |
|----------------|----------------|-------------------------------|
| 5 .. 10 | 2 | 1 .. 2 |
| 4 .. 11 | 3 | 1 .. 3 |
| 5 .. 12 | 4 | 1 .. 4 |
| 6 .. 13 | 5 | 1 .. 4 |
| 7 .. 14 | 6 | 1 .. 4 |
| 8 .. 15 | 7 | 1 .. 4 |
| 9 .. 16 | 8 | 1 .. 4 |

NOTE

It is the user's responsibility to ensure the bit time settings are in compliance with the CAN standard. For bit time calculations, use an IPT (Information Processing Time) of 2, which is the value implemented in the FlexCAN module.

24.4.8.5 Arbitration and Matching Timing

During normal transmission or reception of frames, the arbitration, matching, move-in and move-out processes are executed during certain time windows inside the CAN frame, as shown in [Figure 24-18](#).

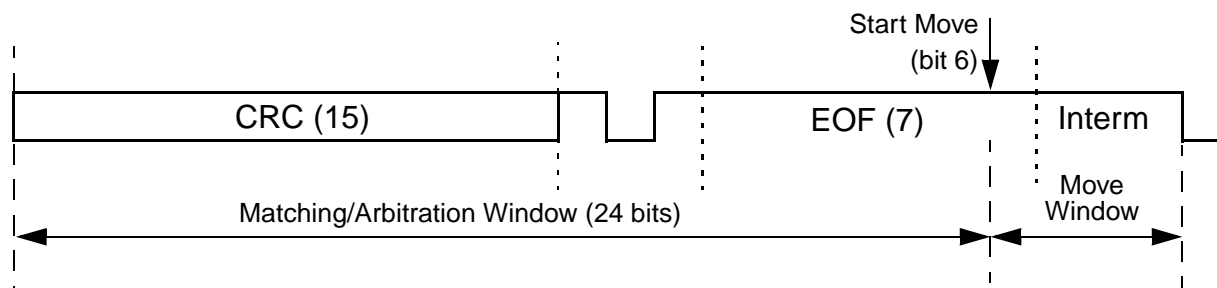
Figure 24-18. Arbitration, Match and Move Time Windows

When doing matching and arbitration, FlexCAN needs to scan the whole Message Buffer memory during the available time slot. In order to have sufficient time to do that, the following requirements must be observed:

- A valid CAN bit timing must be programmed, as indicated in [Table 24-20](#)
- The peripheral clock frequency can not be smaller than the oscillator clock frequency, i.e. the PLL can not be programmed to divide down the oscillator clock
- There must be a minimum ratio between the peripheral clock frequency and the CAN bit rate, as specified in [Table 24-21](#)

Table 24-21. Minimum Ratio Between Peripheral Clock Frequency and CAN Bit Rate

| Number of Message Buffers | Minimum Ratio |
|---------------------------|---------------|
| 16 | 8 |
| 32 | 8 |
| 64 | 16 |

A direct consequence of the first requirement is that the minimum number of time quanta per CAN bit must be 8, so the oscillator clock frequency should be at least 8 times the CAN bit rate. The minimum frequency ratio specified in [Table 24-21](#) can be achieved by choosing a high enough peripheral clock frequency when compared to the oscillator clock frequency, or by adjusting one or more of the bit timing parameters (PRES DIV, PROPSEG, PSEG1, PSEG2). As an example, taking the case of 64 MBs, if the oscillator and peripheral clock frequencies are equal and the CAN bit timing is programmed to have 8 time quanta per bit, then the prescaler factor (PRES DIV + 1) should be at least 2. For prescaler factor equal to one and CAN bit timing with 8 time quanta per bit, the ratio between peripheral and oscillator clock frequencies should be at least 2.

24.4.9 Modes of Operation Details

24.4.9.1 Freeze Mode

This mode is entered by asserting the HALT bit in the FLEXCAN_x_MCR Register or when the MCU is put into Debug Mode. In both cases it is also necessary that the FRZ bit is asserted in the FLEXCAN_x_MCR Register and the module is not in any of the low power modes (Disable, Stop). When Freeze Mode is requested during transmission or reception, FlexCAN does the following:

- Waits to be in either Intermission, Passive Error, Bus Off or Idle state
- Waits for all internal activities like arbitration, matching, move-in and move-out to finish
- Ignores the Rx input pin and drives the Tx pin as recessive
- Stops the prescaler, thus halting all CAN protocol activities
- Grants write access to the Error Counters Register, which is read-only in other modes
- Sets the NOT_RDY and FRZ_ACK bits in FLEXCAN_x_MCR

After requesting Freeze Mode, the user must wait for the FRZ_ACK bit to be asserted in FLEXCAN_x_MCR before executing any other action, otherwise FlexCAN may operate in an unpredictable way. In Freeze mode, all memory mapped registers are accessible.

Exiting Freeze Mode is done in one of the following ways:

- CPU negates the FRZ bit in the FLEXCAN_x_MCR Register
- The MCU is removed from Debug Mode and/or the HALT bit is negated

Once out of Freeze Mode, FlexCAN tries to re-synchronize to the CAN bus by waiting for 11 consecutive recessive bits.

24.4.9.2 Module Disable Mode

This low power mode is entered when the MDIS bit in the FLEXCAN_x_MCR Register is asserted. If the FlexCAN module is disabled during Freeze Mode, the module sends a request to disable the clocks to the CAN Protocol Interface (CPI) and Message Buffer Management (MBM) sub-modules, sets the MDISACK bit and negates the FRZ_ACK bit. If the module is disabled during transmission or reception, FlexCAN does the following:

- Waits to be in either Idle or Bus Off state, or else waits for the third bit of Intermission and then checks it to be recessive
- Waits for all internal activities like arbitration, matching, move-in and move-out to finish
- Ignores its Rx input pin and drives its Tx pin as recessive
- Shuts down the clocks to the CPI and MBM sub-modules
- Sets the NOT_RDY and MDISACK bits in FLEXCAN_x_MCR

The Bus Interface Unit continues to operate, enabling the CPU to access memory mapped registers, except the Free Running Timer, the Error Counter Register and the Message Buffers, which cannot be accessed when the module is in Disable Mode. Exiting from this mode is done by negating the MDIS bit, which will resume the clocks and negate the MDISACK bit.

24.4.9.3 Stop Mode

This is a system low power mode in which all MCU clocks are stopped for maximum power savings. If FlexCAN receives the global Stop Mode request during Freeze Mode, it sets the MDISACK bit, negates the FRZ_ACK bit and then sends a Stop Acknowledge signal to the CPU, in order to shut down the clocks globally. If Stop Mode is requested during transmission or reception, FlexCAN does the following:

- Waits to be in either Idle or Bus Off state, or else waits for the third bit of Intermission and checks it to be recessive
- Waits for all internal activities like arbitration, matching, move-in and move-out to finish
- Ignores its Rx input pin and drives its Tx pin as recessive
- Sets the NOT_RDY and MDISACK bits in FLEXCAN_x_MCR
- Sends a Stop Acknowledge signal to the CPU, so that it can shut down the clocks globally

Exiting Stop Mode is done by CPU resuming the clocks and removing the Stop Mode request.

24.4.10 Interrupts

The module can generate up to 69 interrupt sources (64 interrupts due to message buffers and 5 interrupts due to ORed interrupts from MBs, Bus Off, Error, Tx Warning, and Rx Warning). The number of actual sources depends on the configured number of Message Buffers.

Each one of the message buffers can be an interrupt source, if its corresponding IMASK bit is set. There is no distinction between Tx and Rx interrupts for a particular buffer, under the assumption that the buffer is initialized for either transmission or reception. Each of the buffers has assigned a flag bit in the IFLAG

Registers. The bit is set when the corresponding buffer completes a successful transmission/reception and is cleared when the CPU writes it to '1' (unless another interrupt is generated at the same time).

NOTE

It must be guaranteed that the CPU only clears the bit causing the current interrupt. For this reason, bit manipulation instructions (BSET) must not be used to clear interrupt flags. These instructions may cause accidental clearing of interrupt flags which are set after entering the current interrupt service routine.

If the Rx FIFO is enabled (bit FEN on FLEXCAN_x_MCR set), the interrupts corresponding to MBs 0 to 7 have a different behavior. Bit 7 of the FLEXCAN_x_IFLAG1 becomes the "FIFO Overflow" flag; bit 6 becomes the FIFO Warning flag, bit 5 becomes the "Frames Available in FIFO flag" and bits 4-0 are unused. See [Section 24.3.4.12, Interrupt Flags 1 Register \(FLEXCAN_x_IFLAG1\)](#), for more information.

A combined interrupt for all MBs is also generated by an Or of all the interrupt sources from MBs. This interrupt gets generated when any of the MBs generates an interrupt. In this case the CPU must read the IFLAG Registers to determine which MB caused the interrupt.

The other 4 interrupt sources (Bus Off, Error, Tx Warning, and Rx Warning) generate interrupts like the MB ones, and can be read from the Error and Status Register. The Bus Off, Error, Tx Warning and Rx Warning interrupt mask bits are located in the Control Register.

24.4.11 Bus Interface

The CPU access to FlexCAN registers are subject to the following rules:

- Read and write access to supervisor registers in User Mode results in access error.
- Read and write access to unimplemented or reserved address space also results in access error. Any access to unimplemented MB or Rx Individual Mask Register locations results in access error. Any access to the Rx Individual Mask Register space when the MBFEN bit in FLEXCAN_x_MCR is negated results in access error.
- If MAXMB is programmed with a value smaller than the available number of MBs, then the unused memory space can be used as general purpose RAM space. Note that the Rx Individual Mask Registers can only be accessed in Freeze Mode, and this is still true for unused space within this memory. Note also that reserved words within RAM cannot be used. As an example, suppose FlexCAN is configured with 64 MBs and MAXMB is programmed with zero. The maximum number of MBs in this case becomes one. The MB memory starts at 0x0060, but the space from 0x0060 to 0x007F is reserved (for SMB usage), and the space from 0x0080 to 0x008F is used by the one MB. This leaves us with the available space from 0x0090 to 0x047F. The available memory in the Mask Registers space would be from 0x0884 to 0x097F.

NOTE

Unused MB space must not be used as general purpose RAM while FlexCAN is transmitting and receiving CAN frames.

24.5 Initialization/Application Information

This section provide instructions for initializing the FlexCAN module.

24.5.1 FlexCAN Initialization Sequence

The FlexCAN module may be reset in three ways:

- MCU level hard reset, which resets all memory mapped registers asynchronously
- MCU level soft reset, which resets some of the memory mapped registers synchronously (refer to [Table 24-2](#) to see what registers are affected by soft reset)
- SOFT_RST bit in FLEXCAN_x_MCR, which has the same effect as the MCU level soft reset

Soft reset is synchronous and has to follow an internal request/acknowledge procedure across clock domains. Therefore, it may take some time to fully propagate its effects. The SOFT_RST bit remains asserted while soft reset is pending, so software can poll this bit to know when the reset has completed. Also, soft reset can not be applied while clocks are shut down in any of the low power modes. The low power mode should be exited and the clocks resumed before applying soft reset.

The clock source (CLK_SRC bit) should be selected while the module is in Disable Mode. After the clock source is selected and the module is enabled (MDIS bit negated), FlexCAN automatically goes to Freeze Mode. In Freeze Mode, FlexCAN is un-synchronized to the CAN bus, the HALT and FRZ bits in FLEXCAN_x_MCR Register are set, the internal state machines are disabled and the FRZ_ACK and NOT_RDY bits in the FLEXCAN_x_MCR Register are set. The Tx pin is in recessive state and FlexCAN does not initiate any transmission or reception of CAN frames. Note that the Message Buffers and the Rx Individual Mask Registers are not affected by reset, so they are not automatically initialized.

For any configuration change/initialization it is required that FlexCAN is put into Freeze Mode (see [Section 24.4.9.1, Freeze Mode](#)). The following is a generic initialization sequence applicable to the FlexCAN module:

- Initialize the Module Configuration Register
 - Enable the individual filtering per MB and reception queue features by setting the MBFEN bit
 - Enable the warning interrupts by setting the WRN_EN bit
 - If required, disable frame self reception by setting the SRX_DIS bit
 - Enable the FIFO by setting the FEN bit
 - Enable the abort mechanism by setting the AEN bit
 - Enable the local priority feature by setting the LPRIO_EN bit
- Initialize the Control Register
 - Determine the bit timing parameters: PROPSEG, PSEG1, PSEG2, RJW
 - Determine the bit rate by programming the PRESDIV field
 - Determine the internal arbitration mode (LBUF bit)

- Initialize the Message Buffers
 - The Control and Status word of all Message Buffers must be initialized
 - If FIFO was enabled, the 8-entry ID table must be initialized
 - Other entries in each Message Buffer should be initialized as required
- Initialize the Rx Individual Mask Registers
- Set required interrupt mask bits in the IMASK Registers (for all MB interrupts), in FLEXCAN_x_CTRL Register (for Bus Off and Error interrupts)
- Negate the HALT bit in FLEXCAN_x_MCR

Starting with the last event, FlexCAN attempts to synchronize to the CAN bus.

24.5.2 FlexCAN Addressing and RAM size configurations

There are 3 RAM configurations that can be implemented within the FlexCAN module. The possible configurations are:

- For 16 MBs: 288 bytes for MB memory and 64 bytes for Individual Mask Registers
- For 32 MBs: 544 bytes for MB memory and 128 bytes for Individual Mask Registers

In each configuration the user can program the maximum number of MBs that will take part in the matching and arbitration processes using the MAXMB field in the FLEXCAN_x_MCR Register. For 16 MB configuration, MAXMB can be any number between 0–15. For 32 MB configuration, MAXMB can be any number between 0–31. For 64 MB configuration, MAXMB can be any number between 0–63.



Chapter 25

Deserial Serial Peripheral Interface (DSPI)

25.1 Introduction

This device includes four DSPI blocks (DSPI_A, DSPI_B, DSPI_C, DSPI_D).

Figure 25-1 is a block diagram of a single Deserial Serial Peripheral Interface (DSPI) block.

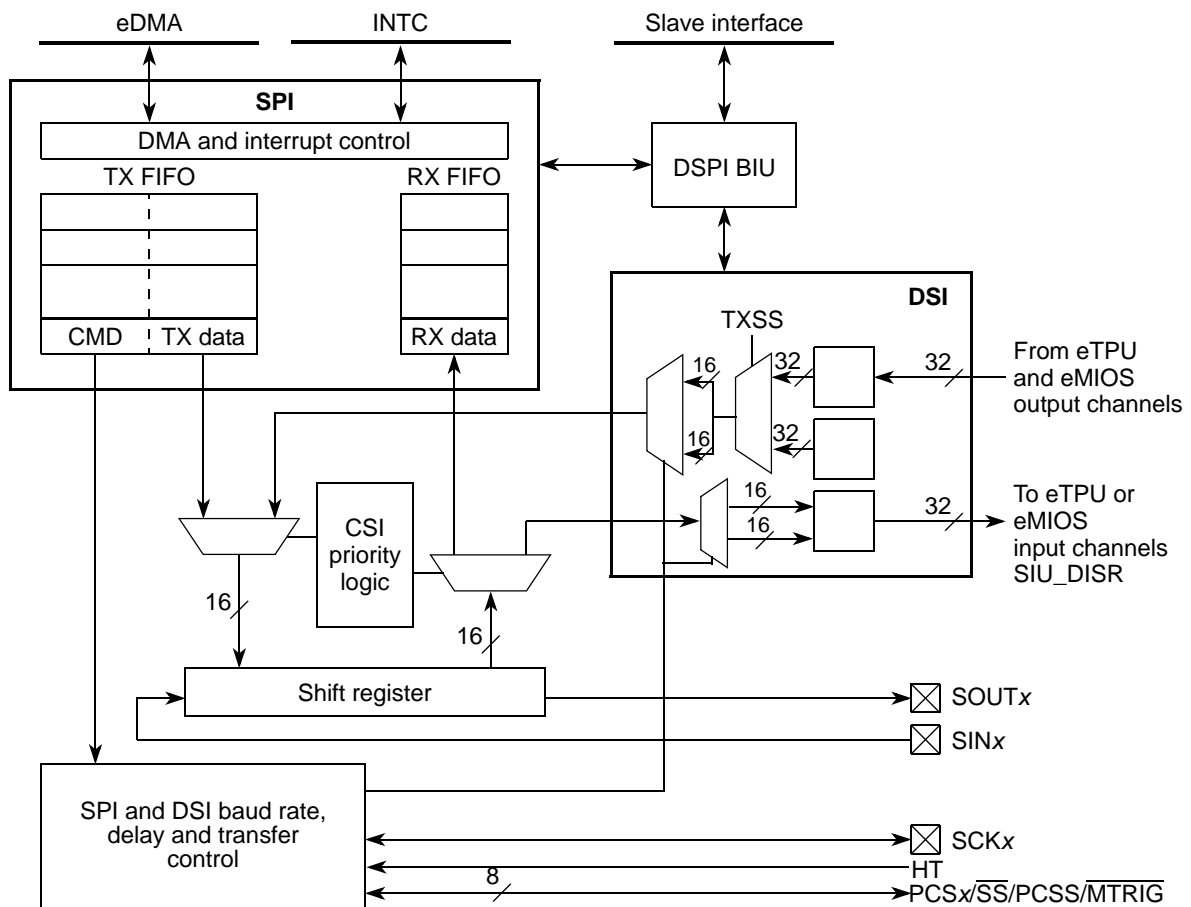

Figure 25-1. DSPI Block Diagram

NOTE

The TXSS signal is described on [Section 25.3.2.1, DSPI Module Configuration Register \(DSPI_MCR\)](#). For details on 32 bits operation see [Section 25.4.9, Timed Serial Bus \(TSB\)](#).

25.1.1 Overview

The Deserial Serial Peripheral Interface (DSPI) block provides a synchronous serial bus for communication between an MCU and an external peripheral device. The DSPI supports pin count reduction through serialization and deserialization of parallel signals transmitted over the SPI serial link. The DSPI has three configurations:

- Serial Peripheral interface (SPI) Configuration where the DSPI operates as a basic SPI or as a queued SPI through the use of internal FIFOs.
- Deserial serial interface (DSI) configuration where the DSPI serializes eTPU and eMIOS output channels and deserializes the received data by placing the data on the eTPU and eMIOS input channels and as inputs to the external interrupt request submodule of the SIU.
- Combined Serial Interface (CSI) Configuration where the DSPI operates in both SPI and DSI configurations interleaving DSI frames with SPI frames, giving priority to SPI frames.

For queued operations the SPI queues reside in system RAM which is external to the DSPI. Data transfers between the queues and the DSPI FIFOs are accomplished through the use of a DMA controller or through host software. [Figure 25-2](#) shows a DSPI with external queues in system RAM.

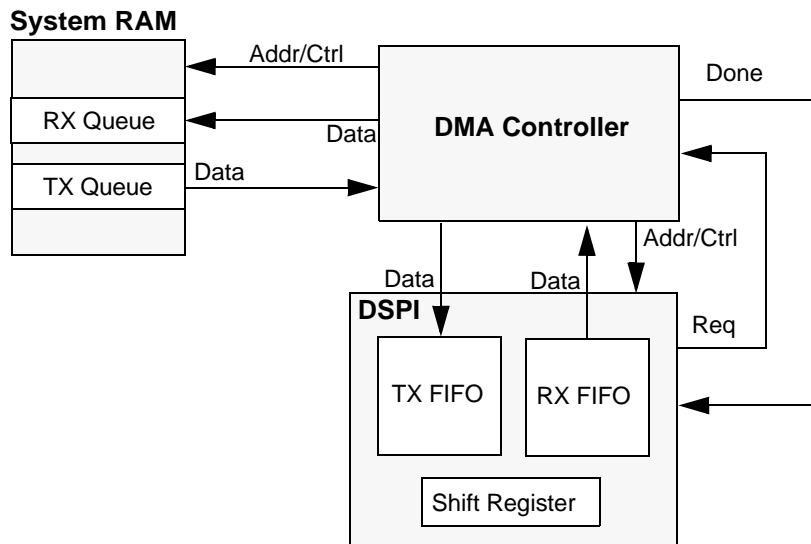

Figure 25-2. DSPI with Queues and DMA

25.1.2 Features

The DSPI supports these SPI features:

- Full-duplex, three-wire synchronous transfers
- Master and Slave Mode
- Buffered transmit operation using the TX FIFO (depth of 4 entries)
- Buffered receive operation using the RX FIFO (depth of 4 entries)
- TX and RX FIFOs can be disabled individually for low-latency updates to SPI queues
- Visibility into TX and RX FIFOs for ease of debugging

- Programmable transfer attributes on a per-frame basis:
 - Eight transfer attribute registers
 - Serial clock with programmable polarity and phase
 - Various programmable delays
 - Programmable serial frame size of 4 to 32 bits, expandable by software control
 - Continuously held chip select capability
- 8 Peripheral Chip Selects, expandable to 256 with external demultiplexer
- Deglitching support for up to 128 Peripheral Chip Select with external demultiplexer
- DMA support for adding entries to TX FIFO and removing entries from RX FIFO:
 - TX FIFO is not full (TFFF)
 - RX FIFO is not empty (RFDF)
- 6 Interrupt conditions:
 - End of queue reached (EOQF)
 - TX FIFO is not full (TFFF)
 - Transfer of current frame complete (TCF)
 - Attempt to transmit with an empty Transmit FIFO (TFUF)
 - RX FIFO is not empty (RFDF)
 - Frame received while Receive FIFO is full (RFOF)
- Modified SPI transfer formats for communication with slower peripheral devices
- Power-saving architectural features
 - Support for Stop Mode

The DSPI also supports pin reduction through serialization and deserialization.

- Two sources of serialized data:
 - DSPI memory-mapped register
 - Parallel Input signals
- Deserialized data is provided as Parallel Output signals and as bits in a memory-mapped register
- Transfer initiation conditions:
 - Continuous
 - Edge sensitive hardware trigger
 - Change in data
- Support for parallel and serial chaining of up to four DSPI blocks
- Pin serialization/deserialization with interleaved SPI frames for control and diagnostics
- Continuous serial communications clock
- Enhanced DSI logic to implement a 32 bits Timed Serial Bus (TSB) configuration, supporting the Micro Second Bus downstream frame format.

DSPI_C clock and data signals are available on LVDS pairs to support microsecond bus functionality. Table 25-1 is an example of the options for PA on two balls, where “true” and “complement” LVDS outputs are multiplexed with SCKC and SINC.

Table 25-1. LVDS Example

| PCR235 ¹ [PA] Selection | PCR236 ² [PA] Selection | SCKC Ball function | SINC Ball function |
|---------------------------------------|---------------------------------------|-----------------------|-----------------------|
| SCKC | SINC | SCKC | SINC |
| LVDS | LVDS | SCK_C_LVDS+ | SCK_C_LVDS- |
| SCKC | LVDS | SCKC | undriven |
| LVDS | SINC | undriven | SINC |

NOTES:

¹ SCKC_SCK_C_LVDSM_GPIO235

² SINC_SCK_C_LVDSM_GPIO236

Signals lvds_opt0 and lvds_opt1 control the voltage swing on the LVDS pad. These two signals are controlled by bits SRC[0:1] of the respective PCR register. Table 25-2 gives the configuration for these bits.

Table 25-2. LVDS Pads Voltage Swing

| SRC[0] | SRC[1] | Current flowing in the driver | Differential Voltage across pad_p and pad_n |
|--------|--------|----------------------------------|--|
| 0 | 0 | normal | default |
| 0 | 1 | decreased | decreased |
| 1 | 0 | increased | increased |
| 1 | 1 | normal | same as default |

25.1.3 DSPI Configurations

The DSPI block has three distinct serial transmission configurations: SPI, DSI and CSI.

25.1.3.1 SPI Configuration

The SPI Configuration allows the DSPI to send and receive serial data. This configuration allows the DSPI to operate as a basic SPI block with the FIFOs providing support for external queue operation. Data to be transmitted and data received reside in separate FIFOs. The FIFOs can be popped and pushed by host software or by a DMA controller.

25.1.3.2 DSI Configuration

In the DSI Configuration the DSPI serializes up to 16 Parallel Input signals or register bits. The DSPI also deserializes the received data to Parallel Output signals or to a memory-mapped register. The data is transferred using a SPI-like protocol.

Specifically in the TSB configuration, detailed on [Section 25.4.9, Timed Serial Bus \(TSB\)](#), the DSPI serializes from 4 to 32 Parallel Input signals or register bits. The TSB downstream frame used to communicate with a single slave is shown in [Figure 25-38](#). The DSPI does not use dedicated pad configuration registers (PCRs). Instead the SIU selects either GPIO, ETPU or EMIOS bits for serialization, and generates serialized DSPI_A, _B, _C, _D outputs accordingly. These then connect to the 4 DSPIs.

25.1.3.3 CSI Configuration

The CSI configuration is a combination of the SPI and DSI configurations. In this configuration the DSPI interleaves DSI data with SPI data. Interleaving is done on the frame boundaries. In this configuration transmission of SPI data has higher priority than DSI data.

25.1.4 Modes of Operation

The DSPI's modes of operation can be divided into two categories: block-specific modes such as Master, Slave, and Module Disable Modes, and MCU-specific modes like External Stop and Debug Modes.

The block-specific modes are entered by host software writing to a register. The MCU-specific modes are controlled by signals external to the DSPI. The MCU-specific modes are modes that the entire MCU may enter, in parallel to the DSPI being in one of its block-specific modes.

25.1.4.1 Master Mode

Master Mode allows the DSPI to initiate and control serial communication. In this mode, the SCK signal and the PCS[x] signals are controlled by the DSPI and configured as outputs.

25.1.4.2 Slave Mode

The Slave Mode allows the DSPI to communicate with SPI/DSI bus masters. In this mode the DSPI responds to externally controlled serial transfers. The DSPI cannot control serial transfers in Slave Mode. In this mode, the SCK signal and the PCS[0]/ \overline{SS} signal are configured as inputs and provided by a bus master.

25.1.4.3 Module Disable Mode

The Module Disable Mode is used for MCU power management. The clock to the non-memory mapped logic in the DSPI can be stopped while in the Module Disable Mode. Logic external to the DSPI is needed to fully implement the Module Disable Mode.

25.1.4.4 External Stop Mode

The External Stop Mode is used for MCU power management. The DSPI supports the Stop Mode mechanism. When a request is made to enter External Stop Mode, the DSPI block acknowledges the request and completes the transfer in progress. When the DSPI reaches the frame boundary it signals that the system clocks to the DSPI block may be shut off.

25.1.4.5 Debug Mode

The Debug Mode is used for system development and debugging. If the device enters Debug Mode while the FRZ bit in the DSPI_MCR is set, the DSPI stops all serial transfers. If the device enters Debug Mode while the FRZ bit is negated, the DSPI behavior is unaffected and remains dictated by the block-specific mode and configuration of the DSPI.

25.2 External Signal Description

25.2.1 Overview

Table 25-3 lists the signals that may connect off chip.

Table 25-3. Signal Properties

| Name | I/O Type | Function | |
|---|----------------|---|-------------------------------|
| | | Master Mode | Slave Mode |
| PCS[0]/ \overline{SS} | Output / Input | Peripheral Chip Select 0 | Slave Select |
| PCS[1] - PCS[3] | Output | Peripheral Chip Select 1 - 3 | Unused |
| PCS[4]/ \overline{MTRIG} ¹ | Output | Peripheral Chip Select 4 | Master Trigger ² |
| PCS[5]/ \overline{PCSS} | Output | Peripheral Chip Select 5 / Peripheral Chip Select Strobe | Unused |
| SIN | Input | Serial Data In | Serial Data In |
| SOUT | Output | Serial Data Out | Serial Data Out |
| SCK | Output / Input | Serial Clock (output) | Serial Clock (input) |
| HT ¹ | Input | Hardware Trigger | Hardware Trigger ² |

NOTES:

¹ MTRIG and HT are internal connections and not available on a pin.

² The Master and Hardware Trigger signals are specifically for MTO mode, and not used in standard SPI slave mode.

25.2.2 Detailed Signal Description

25.2.2.1 PCS[0]/ \overline{SS} — Peripheral Chip Select/Slave Select

In Master Mode, the PCS[0] signal is a Peripheral Chip Select output that selects which slave device the current transmission is intended for.

In Slave Mode, the \overline{SS} signal is a Slave Select input signal that allows a SPI master to select the DSPI as the target for transmission.

25.2.2.2 PCS[1] - PCS[3] — Peripheral Chip Selects 1 - 3

PCS[1] - PCS[3] are Peripheral Chip Select output signals in Master Mode. In Slave Mode these signals are not used.

25.2.2.3 PCS[4]/ $\overline{\text{MTRIG}}$ — Peripheral Chip Select 4/Master Trigger

NOTE

MTRIG is an internal connection and not available on a pin.

In Master Mode, PCS[4] is a Peripheral Chip Select output signal.

In Slave Mode, $\overline{\text{MTRIG}}$ is an output trigger signal that indicates that a change in data to be serialized has occurred. The $\overline{\text{MTRIG}}$ provides a pulse in DSI Configuration when a change in data to be serialized occurs. The $\overline{\text{MTRIG}}$ pulse is four system clock cycles in duration. If the DSPI is in Slave Mode and the MTO is disabled, the PCS[4]/ $\overline{\text{MTRIG}}$ signal is unused.

25.2.2.4 PCS[5]/ $\overline{\text{PCSS}}$ — Peripheral Chip Select 5/Peripheral Chip Select Strobe

PCS[5] is a Peripheral Chip Select output signal. When the DSPI is in Master Mode and PCSSE bit in the DSPI_MCR is negated, this signal is used to select which slave device the current transfer is intended for.

$\overline{\text{PCSS}}$ provides a strobe signal that can be used with an external demultiplexer for deglitching of the PCS signals. When the DSPI is in Master Mode and the PCSSE bit in the DSPI_MCR is set, the $\overline{\text{PCSS}}$ provides the appropriate timing for the decoding of the PCS[0] - PCS[4] and PCS[6] - PCS[7] signals which prevents glitches from occurring.

This signal is not used in Slave Mode.

25.2.2.5 SIN — Serial Input

SIN is a serial data input signal.

25.2.2.6 SOUT — Serial Output

SOUT is a serial data output signal.

25.2.2.7 SCK — Serial Clock

SCK is a serial communication clock signal. In Master Mode, the DSPI generates the SCK. In Slave Mode, SCK is an input from an external bus master.

25.2.2.8 HT — Hardware Trigger

HT is an internal connection and not available on a pin.

HT is a trigger input signal to the DSPI module that is used with Multiple Transfer Operations in DSI Configuration.

In Master Mode while in DSI or CSI Configurations, the HT signal initiates a data transfer when the TRRE bit in the DSPI_DSICR is set and a rising or falling edge is detected on HT. Which edge to trigger on is determined by the TPOL bit in the DSPI_DSICR.

In Slave Mode, the DSPI generates a trigger pulse on the $\overline{\text{MTRIG}}$ pin when a rising or falling edge is detected on HT. Which edge that generates an output pulse is selected by the TPOL bit in the DSPI_DSICR.

25.3 Memory Map and Register Definition

25.3.1 Memory Map

Register accesses to memory addresses that are reserved or undefined result in a transfer error. Write access to the DSPI_POPR register also result in a transfer error.

Table 25-4 shows the DSPI memory map.

Table 25-4. DSPI Memory Map

| Address | Register | Bits | Access | Reset Value | Section/Page |
|---------------------------------------|--|------|--------|-------------|------------------------------|
| DSPI_BASE ¹ | DSPI_MCR—DSPI Module Configuration Register | 32 | R/W | 0x0000_0001 | 25.3.2.1/9 |
| DSPI_BASE+0x4 | Reserved | | | | |
| DSPI_BASE+0x8 | DSPI_TCR—DSPI Transfer Count Register | 32 | R/W | 0x0000_0000 | 25.3.2.2/11 |
| DSPI_BASE+0xC– DSPI_BASE+0x28 | DSPI_CTAR0—DSPI Clock and Transfer Attributes Register 0 - DSPI_CTAR7—DSPI Clock and Transfer Attributes Register 7 | 32 | R/W | 0x7800_0000 | 25.3.2.3/12 |
| DSPI_BASE+0x2C | DSPI_SR—DSPI Status Register | 32 | R/W | 0x0200_0000 | 25.3.2.4/18 |
| DSPI_BASE+0x30 | DSPI_RSER—DSPI DMA/Interrupt Request Select and Enable Register | 32 | R/W | 0x0000_0000 | 25.3.2.5/20 |
| FIFO Registers | | | | | |
| DSPI_BASE+0x34 | DSPI_PUSHR—DSPI Push TX FIFO Register | 32 | R/W | 0x0000_0000 | 25.3.2.6/22 |
| DSPI_BASE+0x38 | DSPI_POPR—DSPI Pop RX FIFO Register | 32 | R | 0x0000_0000 | 25.3.2.7/23 |
| DSPI_BASE+0x3C - DSPI_BASE+0x48 | DSPI_TXFR0—DSPI Transmit FIFO Register 0 - DSPI_TXFR3—DSPI Transmit FIFO Register 3 | 32 | R | 0x0000_0000 | 25.3.2.8/24 |
| DSPI_BASE+0x4C - DSPI_BASE+0x78 | Reserved | | | | |
| DSPI_BASE+0x7C - DSPI_BASE+0x88 | DSPI_RXFR0—DSPI Receive FIFO Register 0 - DSPI_RXFR3—DSPI Receive FIFO Register 3 | 32 | R | 0x0000_0000 | 25.3.2.9/25 |
| DSPI_BASE+0x8C - DSPI_BASE+0xB8 | Reserved | | | | |
| DSI Registers | | | | | |
| DSPI_BASE+0xBC | DSPI_DSICR—DSPI DSI Configuration Register | 32 | R/W | 0x0000_0000 | 25.3.2.10/25 |
| DSPI_BASE+0xC0 | DSPI_SDR—DSPI DSI Serialization Data Register | 32 | R | 0x0000_0000 | 25.3.2.11/27 |

Table 25-4. DSPI Memory Map (continued)

| Address | Register | Bits | Access | Reset Value | Section/Page |
|----------------|---|------|--------|-------------|------------------------------|
| DSPI_BASE+0xC4 | DSPI_AS DR—DSPI DSI Alternate Serialization Data Register | 32 | R/W | 0x0000_0000 | 25.3.2.12/28 |
| DSPI_BASE+0xC8 | DSPI_COMPR—DSPI DSI Transmit Comparison Register | 32 | R | 0x0000_0000 | 25.3.2.13/29 |
| DSPI_BASE+0xCC | DSPI_DDR—DSPI DSI Deserialization Data Register | 32 | R | 0x0000_0000 | 25.3.2.14/29 |
| DSPI_BASE+0xD0 | DSPI_DSICR1—DSPI DSI TSB Configuration Register 1 | 32 | R/W | 0x0000_0000 | 25.3.2.15/30 |

NOTES:

- ¹ DSPI_A = 0xFFFF9_0000
 DSPI_B = 0xFFFF9_4000
 DSPI_C = 0xFFFF9_8000
 DSPI_D = 0xFFFF9_C000

25.3.2 Register Descriptions

25.3.2.1 DSPI Module Configuration Register (DSPI_MCR)

The DSPI_MCR contains bits which configure various attributes associated with DSPI operation. The HALT and MDIS bits can be changed at any time but will only take effect on the next frame boundary. Only the HALT and MDIS bits in the DSPI_MCR may be changed while the DSPI is in the Running state.

Address: DSPI_BASE

Access: R/W

| | 0 | 1 | 2 | 3 | 4 | 5 | 6 | 7 | 8 | 9 | 10 | 11 | 12 | 13 | 14 | 15 |
|-------|------|-----------|---|-------|-----|------|-------|------|---|---|-------|-------|-------|-------|-------|-------|
| R | | | | | | | | | 0 | 0 | | | | | | |
| W | MSTR | CONT_SCKE | | DCONF | FRZ | MTFE | PCSSE | ROOE | | | PCSI5 | PCSI4 | PCSI3 | PCSI2 | PCSI1 | PCSI0 |
| Reset | 0 | 0 | 0 | 0 | 0 | 0 | 0 | 0 | 0 | 0 | 0 | 0 | 0 | 0 | 0 | 0 |

| | 16 | 17 | 18 | 19 | 20 | 21 | 22 | 23 | 24 | 25 | 26 | 27 | 28 | 29 | 30 | 31 |
|-------|------|------|---------|---------|---------|---------|----|---------|----|----|----|----|----|----|----|------|
| R | | | | | | | | | 0 | 0 | 0 | 0 | 0 | 0 | 0 | |
| W | DOZE | MDIS | DIS_TXF | DIS_RXF | CLR_TXF | CLR_RXF | | SMPL_PT | | | | | | | | HALT |
| Reset | 0 | 0 | 0 | 0 | 0 | 0 | 0 | 0 | 0 | 0 | 0 | 0 | 0 | 0 | 0 | 1 |

Figure 25-3. DSPI Module Configuration Register (DSPI_MCR)

Table 25-5. DSPI_MCR Field Descriptions

| Field | Description | | | | | | | | | | |
|-------------------|--|-------|--------------------|----|-----|----|-----|----|-----|----|----------|
| 0 MSTR | Master/Slave Mode Select. The MSTR bit configures the DSPI for either Master Mode or Slave Mode. 0 DSPI is in Slave Mode 1 DSPI is in Master Mode | | | | | | | | | | |
| 1 CONT_SCKE | Continuous SCK Enable. The CONT_SCKE bit enables the Serial Communication Clock (SCK) to run continuously. See Section 25.4.8, Continuous Serial Communications Clock , for details. 0 Continuous SCK disabled 1 Continuous SCK enabled | | | | | | | | | | |
| 2–3 DCONF[0:1] | DSPI Configuration. The DCONF field selects between the three different configurations of the DSPI. The values below list the DCONF values for the various configurations. <table border="1" style="margin-left: auto; margin-right: auto;"> <thead> <tr> <th>DCONF</th> <th>DSPI Configuration</th> </tr> </thead> <tbody> <tr> <td>00</td> <td>SPI</td> </tr> <tr> <td>01</td> <td>DSI</td> </tr> <tr> <td>10</td> <td>CSI</td> </tr> <tr> <td>11</td> <td>Reserved</td> </tr> </tbody> </table> | DCONF | DSPI Configuration | 00 | SPI | 01 | DSI | 10 | CSI | 11 | Reserved |
| DCONF | DSPI Configuration | | | | | | | | | | |
| 00 | SPI | | | | | | | | | | |
| 01 | DSI | | | | | | | | | | |
| 10 | CSI | | | | | | | | | | |
| 11 | Reserved | | | | | | | | | | |
| 4 FRZ | Freeze. The FRZ bit enables the DSPI transfers to be stopped on the next frame boundary when the device enters Debug Mode. 0 Do not stop serial transfers 1 Stop serial transfers | | | | | | | | | | |
| 5 MTFE | Modified Timing Format Enable. The MTFE bit enables a modified transfer format to be used. See Section 25.4.7.4, Modified SPI/DSI Transfer Format (MTFE = 1, CPHA = 1) , for more information. 0 Modified SPI transfer format disabled 1 Modified SPI transfer format enabled | | | | | | | | | | |
| 6 PCSSE | Peripheral Chip Select Strobe Enable. The PCSSE bit enables the PCS[5]/PCSS to operate as an PCS Strobe output signal. See Section 25.4.6.5, Peripheral Chip Select Strobe Enable (PCSS) , for more information. 0 PCS[5]/PCSS is used as the Peripheral Chip Select[5] signal 1 PCS[5]/PCSS is used as an active-low PCS Strobe signal | | | | | | | | | | |
| 7 ROOE | Receive FIFO Overflow Overwrite Enable. The ROOE bit enables an RX FIFO overflow condition to either ignore the incoming serial data or to overwrite existing data. If the RX FIFO is full and new data is received, the data from the transfer that generated the overflow is either ignored or shifted in to the shift register. If the ROOE bit is asserted, the incoming data is shifted in to the shift register. If the ROOE bit is negated, the incoming data is ignored. See Section 25.4.10.6, Receive FIFO Overflow Interrupt Request , for more information. 0 Incoming data is ignored 1 Incoming data is shifted in to the shift register | | | | | | | | | | |
| 8–9 | Reserved, should be cleared | | | | | | | | | | |
| 10–15 PCSiSx | Peripheral Chip Select Inactive State. The PCSiS bit determines the inactive state of the PCSx signal. 0 The inactive state of PCSx is low 1 The inactive state of PCSx is high | | | | | | | | | | |
| 16 DOZE | Doze Enable. The DOZE bit provides support for externally controlled Doze Mode power-saving mechanism. See Section 25.4.11, Power Saving Features , for details. | | | | | | | | | | |

Table 25-5. DSPI_MCR Field Descriptions (continued)

| Field | Description | | | | | | | | | | |
|------------------|--|---------|---|----|---|----|---|----|---|----|----------|
| 17 MDIS | Module Disable. The MDIS bit allows the clock to be stopped to the non-memory mapped logic in the DSPI effectively putting the DSPI in a software controlled power-saving state. See Section 25.4.11, Power Saving Features , for more information. 0 Enable DSPI clocks. 1 Allow external logic to disable DSPI clocks. | | | | | | | | | | |
| 18 DIS_TXF | Disable Transmit FIFO. The DIS_TXF bit provides a mechanism to disable the TX FIFO. When the TX FIFO is disabled, the transmit part of the DSPI operates as a simplified double-buffered SPI. See Section 25.4.3.3, FIFO Disable Operation , for details. 0 TX FIFO is enabled 1 TX FIFO is disabled | | | | | | | | | | |
| 19 DIS_RXF | Disable Receive FIFO. The DIS_RXF bit provides a mechanism to disable the RX FIFO. When the RX FIFO is disabled, the receive part of the DSPI operates as a simplified double-buffered SPI. See Section 25.4.3.3, FIFO Disable Operation , for details. 0 RX FIFO is enabled 1 RX FIFO is disabled | | | | | | | | | | |
| 20 CLR_TXF | Clear TX FIFO. CLR_TXF is used to flush the TX FIFO. Writing a '1' to CLR_TXF clears the TX FIFO Counter. The CLR_TXF bit is always read as zero. 0 Do not clear the TX FIFO Counter 1 Clear the TX FIFO Counter | | | | | | | | | | |
| 21 CLR_RXF | Clear RX FIFO. CLR_RXF is used to flush the RX FIFO. Writing a '1' to CLR_RXF clears the RX Counter. The CLR_RXF bit is always read as zero. 0 Do not clear the RX FIFO Counter 1 Clear the RX FIFO Counter | | | | | | | | | | |
| 22–23 SMPL_PT | SMPL_PT — Sample Point. SMPL_PT allows the host software to select when the DSPI Master samples SIN in Modified Transfer Format. Figure 25-31 shows where the Master can sample the SIN pin. The table below lists the various delayed sample points. <table border="1" style="margin-left: auto; margin-right: auto;"> <thead> <tr> <th>SMPL_PT</th> <th>Number of system clock cycles between odd-numbered edge of SCK and sampling of SIN.</th> </tr> </thead> <tbody> <tr> <td>00</td> <td>0</td> </tr> <tr> <td>01</td> <td>1</td> </tr> <tr> <td>10</td> <td>2</td> </tr> <tr> <td>11</td> <td>Reserved</td> </tr> </tbody> </table> | SMPL_PT | Number of system clock cycles between odd-numbered edge of SCK and sampling of SIN. | 00 | 0 | 01 | 1 | 10 | 2 | 11 | Reserved |
| SMPL_PT | Number of system clock cycles between odd-numbered edge of SCK and sampling of SIN. | | | | | | | | | | |
| 00 | 0 | | | | | | | | | | |
| 01 | 1 | | | | | | | | | | |
| 10 | 2 | | | | | | | | | | |
| 11 | Reserved | | | | | | | | | | |
| 24–30 | Reserved, should be cleared. | | | | | | | | | | |
| 31 HALT | Halt. The HALT bit provides a mechanism by software to start and stop DSPI transfers. See Section 25.4.2, Start and Stop of DSPI Transfers , for details on the operation of this bit. 0 Start transfers 1 Stop transfers | | | | | | | | | | |

25.3.2.2 DSPI Transfer Count Register (DSPI_TCR)

The DSPI_TCR contains a counter that indicates the number of SPI transfers made. The transfer counter is intended to assist in queue management. The user must not write to the DSPI_TCR while the DSPI is in the Running state.

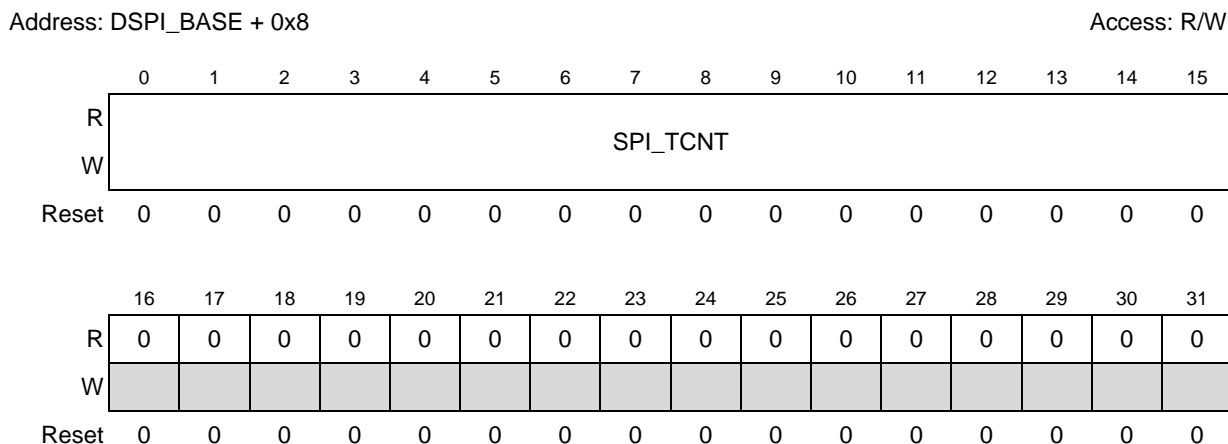

Figure 25-4. DSPI Transfer Count Register (DSPI_TCR)

Table 25-6. DSPI_TCR Field Descriptions

| Field | Description |
|------------------|--|
| 0–15 SPI_TCNT | SPI Transfer Counter. SPI_TCNT is used to keep track of the number of SPI transfers made. The SPI_TCNT field counts the number of SPI transfers the DSPI makes. The SPI_TCNT field is incremented every time the last bit of a SPI frame is transmitted. A value written to SPI_TCNT presets the counter to that value. SPI_TCNT is reset to zero at the beginning of the frame when the CTCNT field is set in the executing SPI command. The Transfer Counter ‘wraps around’ i.e. incrementing the counter past 65535 resets the counter to zero. |
| 16–31 | Reserved, should be cleared. |

25.3.2.3 DSPI Clock and Transfer Attributes Registers 0–7 (DSPI_CTAR0–DSPI_CTAR7)

The DSPI_CTAR registers are used to define different transfer attribute configurations. SPI and DSI transfers select which one of the DSPI_CTARs to get their transfer attributes from. The user must not write to the DSPI_CTAR registers while the DSPI is in the Running state.

In Master Mode, the DSPI_CTAR0 - DSPI_CTAR7 registers define combinations of transfer attributes such as frame size, clock phase and polarity, data bit ordering, baud rate, and various delays. In Slave Mode, a subset of the bitfields in the DSPI_CTAR0 and DSPI_CTAR1 registers are used to set the slave transfer attributes. See the individual bit descriptions for details on which bits are used in Slave Modes.

When the DSPI is configured as a SPI Master, the CTAS field in the command portion of the TX FIFO entry selects which of the DSPI_CTAR register is used. When the DSPI is configured as a SPI bus Slave, the DSPI_CTAR0 register is used.

When the DSPI is configured as a DSI Master, the DSICTAS field in the [DSPI DSI Configuration Register \(DSPI_DSICR\)](#), selects which of the DSPI_CTAR register is used. When the DSPI is configured as a DSI bus Slave, the DSPI_CTAR1 register is used.

In CSI Configuration, the transfer attributes are selected based on whether the current frame is SPI data or DSI data. SPI transfers in CSI Configuration follow the protocol described for SPI Configuration, and DSI transfers in CSI Configuration follow the protocol described for DSI Configuration. CSI Configuration is

only valid in conjunction with Master Mode. See [Section 25.4.5, Combined Serial Interface \(CSI\) Configuration](#), for more details.

In continuous clock mode, only t_{DT} is supported for TSB. However, in TSB non continuous clock mode, both the PDT and DT delays are valid.

Address: DSPI_BASE + 0xC–DSPI_BASE + 0x28

Access: R/W

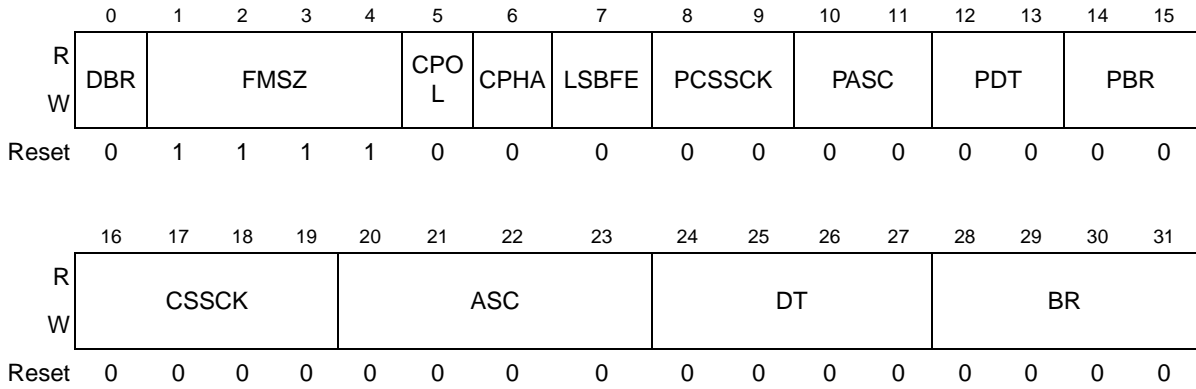

Figure 25-5. DSPI Clock and Transfer Attributes Register 0–7 (DSPI_CTAR0–DSPI_CTAR7)

Table 25-7. DSPI_CTAR n Field Descriptions

| Field | Descriptions | | | | | | | | | | |
|---------------|---|--------|----------------------------------|----|---|----|---|----|---|----|---|
| 0 DBR | <p>Double Baud Rate. The DBR bit doubles the effective baud rate of the Serial Communications Clock (SCK). This field is only used in Master Mode. It effectively halves the Baud Rate division ratio supporting faster frequencies and odd division ratios for the Serial Communications Clock (SCK). When the DBR bit is set, the duty cycle of the Serial Communications Clock (SCK) depends on the value in the Baud Rate Prescaler and the Clock Phase bit as listed in Table 25-8. See the BR[0:3] field description for details on how to compute the baud rate. If the overall baud rate is divide by two or divide by three of the system clock then neither the Continuous SCK Enable or the Modified Timing Format Enable bits should be set.</p> <p>0 The baud rate is computed normally with a 50/50 duty cycle 1 The baud rate is doubled with the duty cycle depending on the Baud Rate Prescaler</p> | | | | | | | | | | |
| 1–4 FMSZ | <p>Frame Size. The FMSZ field selects the number of bits transferred per frame. The FMSZ field is used in Master Mode and Slave Mode. Table 25-9 lists the frame size encodings. When operating in TSB configuration, detailed in Section 25.4.9, Timed Serial Bus (TSB), the FMSZ defines the point with in the 32-bit (maximum length) frame where control of the CS switches from the DSPI_DSICR to the DSPI_DSICR1 register. The cross over point must range between 4 bits and 16 bits and is encoded per Table 25-9. The remaining frame after the cross over point, regardless of how many bits are remaining, will be controlled by the DSPI_DSICR1 register.</p> | | | | | | | | | | |
| 5 CPOL | <p>Clock Polarity. The CPOL bit selects the inactive state of the Serial Communications Clock (SCK). This bit is used in both Master and Slave Mode. For successful communication between serial devices, the devices must have identical clock polarities. When the Continuous Selection Format is selected, switching between clock polarities without stopping the DSPI can cause errors in the transfer due to the peripheral device interpreting the switch of clock polarity as a valid clock edge.</p> <p>0 The inactive state value of SCK is low 1 The inactive state value of SCK is high</p> | | | | | | | | | | |
| 6 CPHA | <p>Clock Phase. The CPHA bit selects which edge of SCK causes data to change and which edge causes data to be captured. This bit is used in both Master and Slave Mode. For successful communication between serial devices, the devices must have identical clock phase settings. Continuous SCK is only supported for CPHA=1.</p> <p>0 Data is captured on the leading edge of SCK and changed on the following edge 1 Data is changed on the leading edge of SCK and captured on the following edge</p> | | | | | | | | | | |
| 7 LSBFE | <p>LSB First. The LSBFE bit selects if the LSB or MSB of the frame is transferred first. This bit is only used in Master Mode. When operating in TSB configuration, this bit should be always 1.</p> <p>0 Data is transferred MSB first 1 Data is transferred LSB first</p> | | | | | | | | | | |
| 8–9 PCSSCK | <p>PCS to SCK Delay Prescaler. The PCSSCK field selects the prescaler value for the delay between assertion of PCS and the first edge of the SCK. This field is only used in Master Mode. The table below lists the prescaler values. See the CSSCK[0:3] field description for details on how to compute the PCS to SCK Delay.</p> <table border="1" style="margin-left: auto; margin-right: auto;"> <thead> <tr> <th>PCSSCK</th> <th>PCS to SCK Delay Prescaler Value</th> </tr> </thead> <tbody> <tr> <td>00</td> <td>1</td> </tr> <tr> <td>01</td> <td>3</td> </tr> <tr> <td>10</td> <td>5</td> </tr> <tr> <td>11</td> <td>7</td> </tr> </tbody> </table> | PCSSCK | PCS to SCK Delay Prescaler Value | 00 | 1 | 01 | 3 | 10 | 5 | 11 | 7 |
| PCSSCK | PCS to SCK Delay Prescaler Value | | | | | | | | | | |
| 00 | 1 | | | | | | | | | | |
| 01 | 3 | | | | | | | | | | |
| 10 | 5 | | | | | | | | | | |
| 11 | 7 | | | | | | | | | | |

Table 25-7. DSPI_CTAR n Field Descriptions (continued)

| Field | Descriptions | | | | | | | | | | |
|---------------|---|------|--------------------------------------|----|---|----|---|----|---|----|---|
| 10–11 PASC | <p>After SCK Delay Prescaler. The PASC field selects the prescaler value for the delay between the last edge of SCK and the negation of PCS. This field is only used in Master Mode. The table below lists the prescaler values. See the ASC[0:3] field description for details on how to compute the After SCK Delay.</p> <table border="1" data-bbox="566 422 1205 659"> <thead> <tr> <th>PASC</th> <th>After SCK Delay Prescaler Value</th> </tr> </thead> <tbody> <tr> <td>00</td> <td>1</td> </tr> <tr> <td>01</td> <td>3</td> </tr> <tr> <td>10</td> <td>5</td> </tr> <tr> <td>11</td> <td>7</td> </tr> </tbody> </table> | PASC | After SCK Delay Prescaler Value | 00 | 1 | 01 | 3 | 10 | 5 | 11 | 7 |
| PASC | After SCK Delay Prescaler Value | | | | | | | | | | |
| 00 | 1 | | | | | | | | | | |
| 01 | 3 | | | | | | | | | | |
| 10 | 5 | | | | | | | | | | |
| 11 | 7 | | | | | | | | | | |
| 12–13 PDT | <p>Delay after Transfer Prescaler. The PDT field selects the prescaler value for the delay between the negation of the PCS signal at the end of a frame and the assertion of PCS at the beginning of the next frame. The PDT field is only used in Master Mode. The table below lists the prescaler values. See the DT[0:3] field description for details on how to compute the Delay after Transfer.</p> <table border="1" data-bbox="587 842 1190 1079"> <thead> <tr> <th>PDT</th> <th>Delay after Transfer Prescaler Value</th> </tr> </thead> <tbody> <tr> <td>00</td> <td>1</td> </tr> <tr> <td>01</td> <td>3</td> </tr> <tr> <td>10</td> <td>5</td> </tr> <tr> <td>11</td> <td>7</td> </tr> </tbody> </table> | PDT | Delay after Transfer Prescaler Value | 00 | 1 | 01 | 3 | 10 | 5 | 11 | 7 |
| PDT | Delay after Transfer Prescaler Value | | | | | | | | | | |
| 00 | 1 | | | | | | | | | | |
| 01 | 3 | | | | | | | | | | |
| 10 | 5 | | | | | | | | | | |
| 11 | 7 | | | | | | | | | | |
| 14–15 PBR | <p>Baud Rate Prescal. The PBR field selects the prescaler value for the baud rate. This field is only used in Master Mode. The Baud Rate is the frequency of the Serial Communications Clock (SCK). The system clock is divided by the prescaler value before the baud rate selection takes place. The Baud Rate Prescaler values are listed in the table below. See the BR[0:3] field description for details on how to compute the baud rate.</p> <table border="1" data-bbox="604 1289 1175 1526"> <thead> <tr> <th>PBR</th> <th>Baud Rate Prescaler Value</th> </tr> </thead> <tbody> <tr> <td>00</td> <td>2</td> </tr> <tr> <td>01</td> <td>3</td> </tr> <tr> <td>10</td> <td>5</td> </tr> <tr> <td>11</td> <td>7</td> </tr> </tbody> </table> | PBR | Baud Rate Prescaler Value | 00 | 2 | 01 | 3 | 10 | 5 | 11 | 7 |
| PBR | Baud Rate Prescaler Value | | | | | | | | | | |
| 00 | 2 | | | | | | | | | | |
| 01 | 3 | | | | | | | | | | |
| 10 | 5 | | | | | | | | | | |
| 11 | 7 | | | | | | | | | | |

Table 25-7. DSPI_CTAR_n Field Descriptions (continued)

| Field | Descriptions |
|----------------|--|
| 16–19 CSSCK | <p>PCS to SCK Delay Scaler. The CSSCK field selects the scaler value for the PCS to SCK delay. This field is only used in Master Mode. The PCS to SCK Delay is the delay between the assertion of PCS and the first edge of the SCK. Table 25-10 list the scaler values. The PCS to SCK Delay is a multiple of the system clock period and it is computed according to the following equation:</p> $t_{CSC} = \frac{1}{f_{periph}} \times PCSSCK \times CSSCK \quad \text{Eqn. 25-1}$ <p>See Section 25.4.6.2, PCS to SCK Delay (tCSC), for more details.</p> |
| 20–23 ASC | <p>After SCK Delay Scaler. The ASC field selects the scaler value for the After SCK Delay. This field is only used in Master Mode. The After SCK Delay is the delay between the last edge of SCK and the negation of PCS. Table 25-11 list the scaler values. The After SCK Delay is a multiple of the system clock period, and it is computed according to the following equation:</p> $t_{ASC} = \frac{1}{f_{periph}} \times PASC \times ASC \quad \text{Eqn. 25-2}$ <p>See Section 25.4.6.3, After SCK Delay (tASC), for more details.</p> |
| 24–27 DT | <p>Delay after Transfer Scaler. The DT field selects the Delay after Transfer Scaler. This field is only used in Master Mode. The Delay after Transfer is the time between the negation of the PCS signal at the end of a frame and the assertion of PCS at the beginning of the next frame. Table 25-12 lists the scaler values. In the Continuous Serial Communications Clock operation the DT value is fixed to one TSCK, except when the TSBC bit from DSPI_DSICR register is enabling the TSB configuration. See detailed information on Section 25.4.9, Timed Serial Bus (TSB). The Delay after Transfer is a multiple of the system clock period and it is computed according to the following equation:</p> $t_{DT} = \frac{1}{f_{periph}} \times PDT \times DT \quad \text{Eqn. 25-3}$ <p>See Section 25.4.6.4, Delay after Transfer (tDT), for more details.</p> |
| 28–31 BR | <p>Baud Rate Scaler. The BR field selects the scaler value for the baud rate. This field is only used in Master Mode. The prescaled system clock is divided by the Baud Rate Scaler to generate the frequency of the SCK. Table 25-13 lists the Baud Rate Scaler values. The baud rate is computed according to the following equation:</p> $\text{SCK baud rate} = \frac{f_{periph}}{PBR} \times \frac{1 + DBR}{BR} \quad \text{Eqn. 25-4}$ <p>See Section 25.4.6.1, Baud Rate Generator, for more details.</p> |

Table 25-8. DSPI SCK Duty Cycle

| DBR | CPHA | PBR | SCK Duty Cycle |
|-----|------|-----|----------------|
| 0 | any | any | 50/50 |
| 1 | 0 | 00 | 50/50 |
| 1 | 0 | 01 | 33/66 |
| 1 | 0 | 10 | 40/60 |
| 1 | 0 | 11 | 43/57 |

Table 25-8. DSPI SCK Duty Cycle (continued)

| DBR | CPHA | PBR | SCK Duty Cycle |
|-----|------|-----|----------------|
| 1 | 1 | 00 | 50/50 |
| 1 | 1 | 01 | 66/33 |
| 1 | 1 | 10 | 60/40 |
| 1 | 1 | 11 | 57/43 |

Table 25-9. DSPI Transfer Frame Size

| FMSZ | Framesize | FMSZ | Framesize |
|------|-----------|------|-----------|
| 0000 | Reserved | 1000 | 9 |
| 0001 | Reserved | 1001 | 10 |
| 0010 | Reserved | 1010 | 11 |
| 0011 | 4 | 1011 | 12 |
| 0100 | 5 | 1100 | 13 |
| 0101 | 6 | 1101 | 14 |
| 0110 | 7 | 1110 | 15 |
| 0111 | 8 | 1111 | 16 |

Table 25-10. DSPI PCS to SCK Delay Scaler

| CSSCK | PCS to SCK Delay Scaler Value | CSSCK | PCS to SCK Delay Scaler Value |
|-------|-------------------------------|-------|-------------------------------|
| 0000 | 2 | 1000 | 512 |
| 0001 | 4 | 1001 | 1024 |
| 0010 | 8 | 1010 | 2048 |
| 0011 | 16 | 1011 | 4096 |
| 0100 | 32 | 1100 | 8192 |
| 0101 | 64 | 1101 | 16384 |
| 0110 | 128 | 1110 | 32768 |
| 0111 | 256 | 1111 | 65536 |

Table 25-11. DSPI After SCK Delay Scaler

| ASC | After SCK Delay Scaler Value | ASC | After SCK Delay Scaler Value |
|------|------------------------------|------|------------------------------|
| 0000 | 2 | 1000 | 512 |
| 0001 | 4 | 1001 | 1024 |
| 0010 | 8 | 1010 | 2048 |
| 0011 | 16 | 1011 | 4096 |

Table 25-11. DSPI After SCK Delay Scaler (continued)

| ASC | After SCK Delay Scaler Value | ASC | After SCK Delay Scaler Value |
|------|------------------------------|------|------------------------------|
| 0100 | 32 | 1100 | 8192 |
| 0101 | 64 | 1101 | 16384 |
| 0110 | 128 | 1110 | 32768 |
| 0111 | 256 | 1111 | 65536 |

Table 25-12. DSPI Delay after Transfer Scaler

| DT | Delay after Transfer Scaler Value | DT | Delay after Transfer Scaler Value |
|------|-----------------------------------|------|-----------------------------------|
| 0000 | 2 | 1000 | 512 |
| 0001 | 4 | 1001 | 1024 |
| 0010 | 8 | 1010 | 2048 |
| 0011 | 16 | 1011 | 4096 |
| 0100 | 32 | 1100 | 8192 |
| 0101 | 64 | 1101 | 16384 |
| 0110 | 128 | 1110 | 32768 |
| 0111 | 256 | 1111 | 65536 |

Table 25-13. DSPI Baud Rate Scaler

| BR | Baud Rate Scaler Value | BR | Baud Rate Scaler Value |
|------|------------------------|------|------------------------|
| 0000 | 2 | 1000 | 256 |
| 0001 | 4 | 1001 | 512 |
| 0010 | 6 | 1010 | 1024 |
| 0011 | 8 | 1011 | 2048 |
| 0100 | 16 | 1100 | 4096 |
| 0101 | 32 | 1101 | 8192 |
| 0110 | 64 | 1110 | 16384 |
| 0111 | 128 | 1111 | 32768 |

25.3.2.4 DSPI Status Register (DSPI_SR)

The DSPI_SR contains status and flag bits. The bits reflect the status of the DSPI and indicate the occurrence of events that can generate interrupt or DMA requests. Software can clear flag bits in the DSPI_SR by writing a ‘1’ to it. Writing a ‘0’ to a flag bit has no effect. This register may not be writable in MDIS Mode due to the use of power saving mechanisms.

Address: DSPI_BASE + 0x2C

Access: R/W

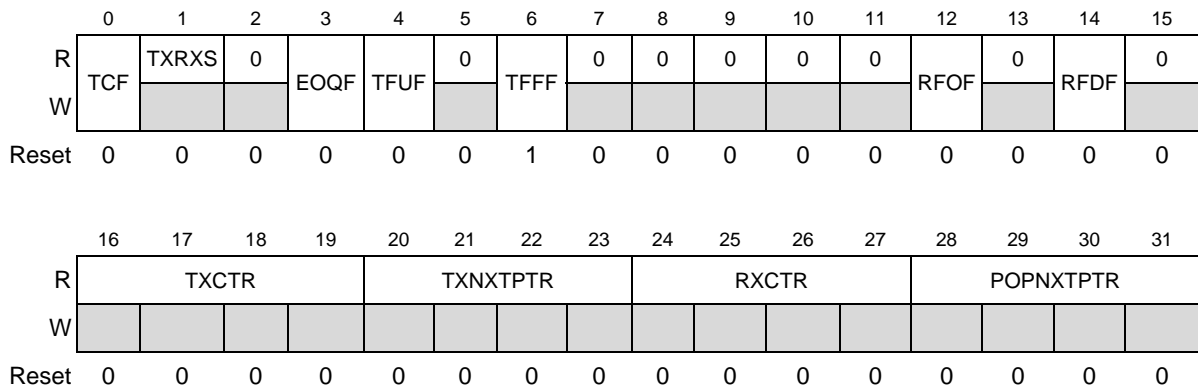

Figure 25-6. DSPI Status Register (DSPI_SR)

Table 25-14. DSPI_SR Field Descriptions

| Field | Description |
|------------|--|
| 0 TCF | Transfer Complete Flag. The TCF bit indicates that all bits in a frame have been shifted out. The TCF bit is set at the end of the frame transfer. The TCF bit remains set until cleared by software. 0 Transfer not complete 1 Transfer complete |
| 1 TXRXS | TX & RX Status. The TXRXS bit reflects the status of the DSPI. See Section 25.4.2, Start and Stop of DSPI Transfers , for information on how what causes this bit to be negated or asserted. 0 TX and RX operations are disabled (DSPI is in STOPPED state) 1 TX and RX operations are enabled (DSPI is in RUNNING state) |
| 2 | Reserved, should be cleared. |
| 3 EOQF | End of Queue Flag. The EOQF bit indicates that transmission in progress is the last entry in a queue. The EOQF bit is set when TX FIFO entry has the EOQ bit set in the command halfword and the end of the transfer is reached. The EOQF bit remains set until cleared by software. When the EOQF bit is set, the TXRXS bit is automatically cleared. 0 EOQ is not set in the executing command 1 EOQ bit is set in the executing SPI command |
| 4 TFUF | Transmit FIFO Underflow Flag. The TFUF bit indicates that an underflow condition in the TX FIFO has occurred. The transmit underflow condition is detected only for DSPI blocks operating in slave mode and SPI configuration. The TFUF bit is set when the TX FIFO of a DSPI operating in SPI slave mode is empty, and a transfer is initiated by an external SPI master. The TFUF bit remains set until cleared by software. 0 TX FIFO underflow has not occurred 1 TX FIFO underflow has occurred |
| 5 | Reserved, should be cleared. |
| 6 TFFF | Transmit FIFO Fill Flag. The TFFF bit provides a method for the DSPI to request more entries to be added to the TX FIFO. The TFFF bit is set while the TX FIFO is not full. The TFFF bit can be cleared by host software or an acknowledgement from the DMA controller when the TX FIFO is full. 0 TX FIFO is full 1 TX FIFO is not full |
| 7–11 | Reserved, should be cleared. |

Table 25-14. DSPI_SR Field Descriptions (continued)

| Field | Description |
|-------------------|--|
| 12 RFOF | Receive FIFO Overflow Flag. The RFOF bit indicates that an overflow condition in the RX FIFO has occurred. The bit is set when the RX FIFO and shift register are full and a transfer is initiated. The bit remains set until cleared by software. 0 RX FIFO overflow has not occurred 1 RX FIFO overflow has occurred |
| 13 | Reserved, should be cleared. |
| 14 RFDF | Receive FIFO Drain Flag. The RFDF bit provides a method for the DSPI to request that entries be removed from the RX FIFO. The bit is set while the RX FIFO is not empty. The RFDF bit can be cleared by host software or an acknowledgement from the DMA controller when the RX FIFO is empty. 0 RX FIFO is empty 1 RX FIFO is not empty |
| 15 | Reserved, should be cleared. |
| 16–20 TXCTR | TX FIFO Counter. The TXCTR field indicates the number of valid entries in the TX FIFO. The TXCTR is incremented every time the DSPI_PUSH is written. The TXCTR is decremented every time a SPI command is executed and the SPI data is transferred to the shift register. |
| 20–23 TXNXTPTR | Transmit Next Pointer. The TXNXTPTR field indicates which TX FIFO Entry will be transmitted during the next transfer. The TXNXTPTR field is updated every time SPI data is transferred from the TX FIFO to the shift register. See Section 25.4.10.4, Transmit FIFO Underflow Interrupt Request , for more details. |
| 24–27 RXCTR | RX FIFO Counter. The RXCTR field indicates the number of entries in the RX FIFO. The RXCTR is decremented every time the DSPI_POP is read. The RXCTR is incremented every time data is transferred from the shift register to the RX FIFO. |
| 28–31 POPXTPTR | Pop Next Pointer. The POPXTPTR field contains a pointer to the RX FIFO entry that will be returned when the DSPI_POP is read. The POPXTPTR is updated when the DSPI_POP is read. See Section 25.4.3.5, Receive First In First Out (RX FIFO) Buffering Mechanism , for more details. |

25.3.2.5 DSPI DMA/Interrupt Request Select and Enable Register (DSPI_RSER)

The DSPI_RSER serves two purposes. It enables flag bits in the DSPI_SR to generate DMA requests or interrupt requests. The DSPI_RSER also selects the type of request to be generated. See the individual bit descriptions for information on the types of requests the bits support. The user must not write to the DSPI_RSER while the DSPI is in the Running state.

Address: DSPI_BASE + 0x30

Access: R/W

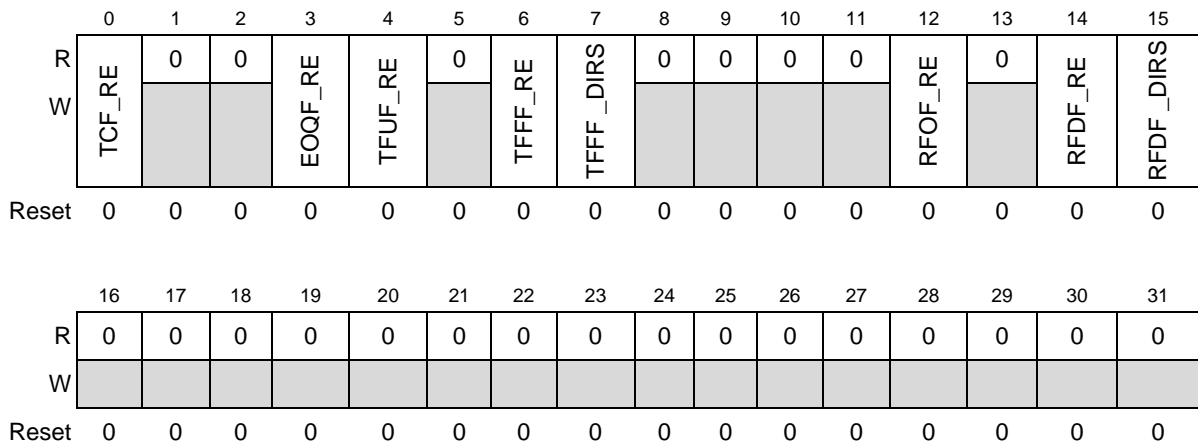

Figure 25-7. DSPI DMA/Interrupt Request Select and Enable Register (DSPI_RSER)

Table 25-15. DSPI_RSER Field Descriptions

| Field | Description |
|----------------|--|
| 0 TCF_RE | Transmission Complete Request Enable. The TCF_RE bit enables TCF flag in the DSPI_SR to generate an interrupt request. 0 TCF interrupt requests are disabled 1 TCF interrupt requests are enabled |
| 1–2 | Reserved, should be cleared. |
| 3 EOQF_RE | DSPI Finished Request Enable. The EOQF_RE bit enables the EOQF flag in the DSPI_SR to generate an interrupt request. 0 EOQF interrupt requests are disabled 1 EOQF interrupt requests are enabled |
| 4 TFUF_RE | Transmit FIFO Underflow Request Enable. The TFUF_RE bit enables the TFUF flag in the DSPI_SR to generate an interrupt request. 0 TFUF interrupt requests are disabled 1 TFUF interrupt requests are enabled |
| 5 | Reserved, should be cleared. |
| 6 TFFF_RE | Transmit FIFO Fill Request Enable. The TFFF_RE bit enables the TFFF flag in the DSPI_SR to generate a request. The TFFF_DIRS bit selects between generating an interrupt request or a DMA requests. 0 TFFF interrupt requests or DMA requests are disabled 1 TFFF interrupt requests or DMA requests are enabled |
| 7 TFFF_DIRS | Transmit FIFO Fill DMA or Interrupt Request Select. The TFFF_DIRS bit selects between generating a DMA request or an interrupt request. When the TFFF flag bit in the DSPI_SR is set, and the TFFF_RE bit in the DSPI_RSER register is set, this bit selects between generating an interrupt request or a DMA request. 0 Interrupt request will be generated 1 DMA request will be generated |
| 8–11 | Reserved, should be cleared. |

Table 25-15. DSPI_RSER Field Descriptions (continued)

| Field | Description |
|-----------------|---|
| 12 RFOF_RE | Receive FIFO Overflow Request Enable. The RFOF_RE bit enables the RFOF flag in the DSPI_SR to generate an interrupt requests. 0 RFOF interrupt requests are disabled 1 RFOF interrupt requests are enabled |
| 13 | Reserved, should be cleared. |
| 14 RFDF_RE | Receive FIFO Drain Request Enable. The RFDF_RE bit enables the RFDF flag in the DSPI_SR to generate a request. The RFDF_DIRS bit selects between generating an interrupt request or a DMA request. 0 RFDF interrupt requests or DMA requests are disabled 1 RFDF interrupt requests or DMA requests are enabled |
| 15 RFDF_DIRS | Receive FIFO Drain DMA or Interrupt Request Select. The RFDF_DIRS bit selects between generating a DMA request or an interrupt request. When the RFDF flag bit in the DSPI_SR is set, and the RFDF_RE bit in the DSPI_RSER register is set, the RFDF_DIRS bit selects between generating an interrupt request or a DMA request. 0 Interrupt request will be generated 1 DMA request will be generated |
| 16–31 | Reserved, should be cleared. |

25.3.2.6 DSPI PUSH TX FIFO Register (DSPI_PUSHR)

The DSPI_PUSHR provides a means to write to the TX FIFO. Data written to this register is transferred to the TX FIFO. See [Section 25.4.3.4, Transmit First In First Out \(TX FIFO\) Buffering Mechanism](#), for more information. Eight or sixteen bit write accesses to the DSPI_PUSHR will transfer 32 bits to the TX FIFO.

Address: DSPI_BASE + 0x34

Access: R/W

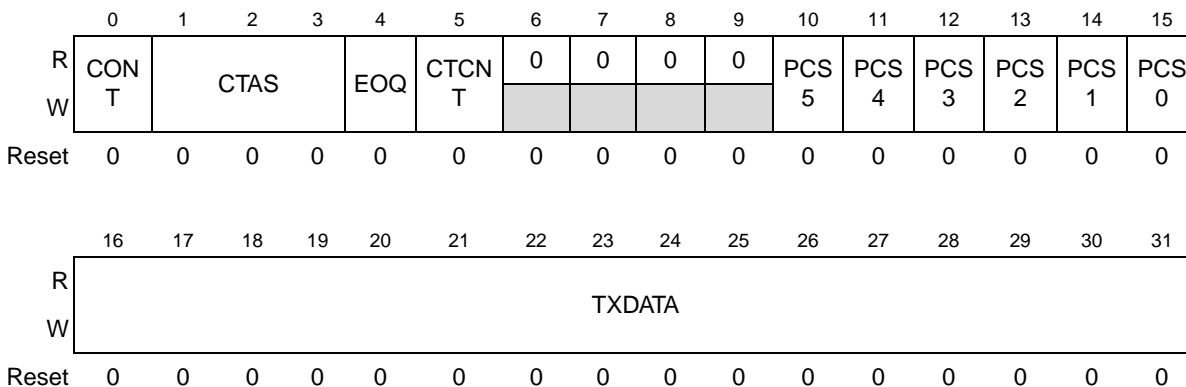

Figure 25-8. DSPI PUSH TX FIFO Register (DSPI_PUSHR)

Table 25-16. DSPI_PUSHR Field Descriptions

| Field | Descriptions | | | | | | | | | | | | | | | | | | | | |
|-----------------|--|------|--|------|--|-----|------------|-----|------------|-----|------------|-----|------------|-----|------------|-----|------------|-----|------------|-----|------------|
| 0 CONT | Continuous Peripheral Chip Select Enable. The CONT bit selects a Continuous Selection Format. The bit is used in SPI Master Mode. The bit enables the selected PCS signals to remain asserted between transfers. See Section 25.4.7.5, Continuous Selection Format , for more information. 0 Return Peripheral Chip Select signals to their inactive state between transfers 1 Keep Peripheral Chip Select signals asserted between transfers | | | | | | | | | | | | | | | | | | | | |
| 1–3 CTAS | Clock and Transfer Attributes Select. The CTAS field selects which of the DSPI_CTAR register is used to set the transfer attributes for the associated SPI frame. The field is only used in SPI Master Mode. In SPI Slave Mode DSPI_CTAR0 is used. The table below shows how the CTAS values map to the DSPI_CTAR registers. The number of DSPI_CTAR registers is implementation specific. <table border="1" style="margin: 10px auto;"> <thead> <tr> <th>CTAS</th> <th>Use Clock and Transfer Attributes from</th> <th>CTAS</th> <th>Use Clock and Transfer Attributes from</th> </tr> </thead> <tbody> <tr> <td>000</td> <td>DSPI_CTAR0</td> <td>100</td> <td>DSPI_CTAR4</td> </tr> <tr> <td>001</td> <td>DSPI_CTAR1</td> <td>101</td> <td>DSPI_CTAR5</td> </tr> <tr> <td>010</td> <td>DSPI_CTAR2</td> <td>110</td> <td>DSPI_CTAR6</td> </tr> <tr> <td>011</td> <td>DSPI_CTAR3</td> <td>111</td> <td>DSPI_CTAR7</td> </tr> </tbody> </table> | CTAS | Use Clock and Transfer Attributes from | CTAS | Use Clock and Transfer Attributes from | 000 | DSPI_CTAR0 | 100 | DSPI_CTAR4 | 001 | DSPI_CTAR1 | 101 | DSPI_CTAR5 | 010 | DSPI_CTAR2 | 110 | DSPI_CTAR6 | 011 | DSPI_CTAR3 | 111 | DSPI_CTAR7 |
| CTAS | Use Clock and Transfer Attributes from | CTAS | Use Clock and Transfer Attributes from | | | | | | | | | | | | | | | | | | |
| 000 | DSPI_CTAR0 | 100 | DSPI_CTAR4 | | | | | | | | | | | | | | | | | | |
| 001 | DSPI_CTAR1 | 101 | DSPI_CTAR5 | | | | | | | | | | | | | | | | | | |
| 010 | DSPI_CTAR2 | 110 | DSPI_CTAR6 | | | | | | | | | | | | | | | | | | |
| 011 | DSPI_CTAR3 | 111 | DSPI_CTAR7 | | | | | | | | | | | | | | | | | | |
| 4 EOQ | End Of Queue. The EOQ bit provides a means for host software to signal to the DSPI that the current SPI transfer is the last in a queue. At the end of the transfer the EOQF bit in the DSPI_SR is set. 0 The SPI data is not the last data to transfer 1 The SPI data is the last data to transfer | | | | | | | | | | | | | | | | | | | | |
| 5 CTCNT | Clear SPI_TCNT. The CTCNT provides a means for host software to clear the SPI transfer counter. The CTCNT bit clears the SPI_TCNT field in the DSPI_TCR register. The SPI_TCNT field is cleared before transmission of the current SPI frame begins. 0 Do not clear SPI_TCNT field in the DSPI_TCR 1 Clear SPI_TCNT field in the DSPI_TCR | | | | | | | | | | | | | | | | | | | | |
| 6–9 | Reserved, should be cleared | | | | | | | | | | | | | | | | | | | | |
| 10–15 PCSx | Peripheral Chip Select 0–5. The PCS bits select which PCS signals will be asserted for the transfer. 0 Negate the PCS[x] signal 1 Assert the PCS[x] signal | | | | | | | | | | | | | | | | | | | | |
| 16–31 TXDATA | Transmit Data. The TXDATA field holds SPI data to be transferred according to the associated SPI command. | | | | | | | | | | | | | | | | | | | | |

25.3.2.7 DSPI POP RX FIFO Register (DSPI_POPR)

The DSPI_POPR provides a means to read the RX FIFO. See [Section 25.4.3.5, Receive First In First Out \(RX FIFO\) Buffering Mechanism](#), for a description of the RX FIFO operations. Eight or sixteen bit read accesses to the DSPI_POPR will read from the RX FIFO and update the counter and pointer.

Address: DSPI_BASE + 0x38

Access: Read Only

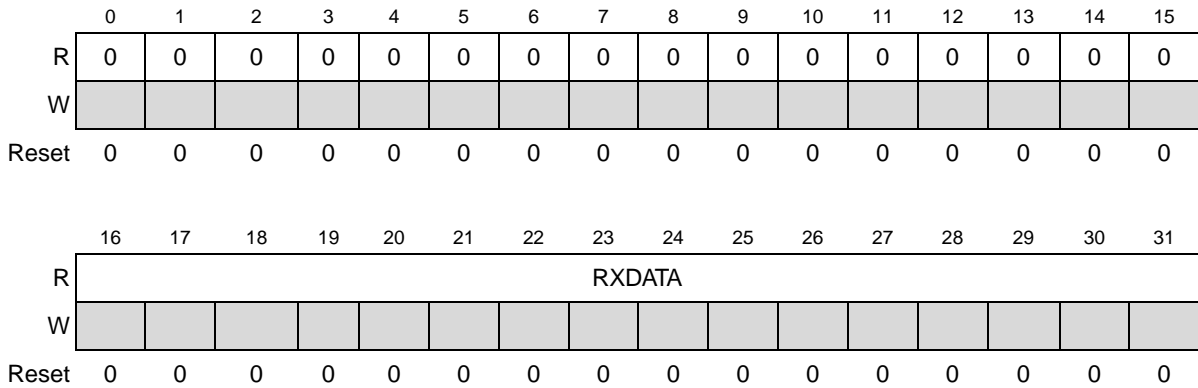

Figure 25-9. DSPI POP RX FIFO Register (DSPI_POPR)

Table 25-17. DSPI_POPR Field Descriptions

| Field | Description |
|-----------------|---|
| 0–15 | Reserved, should be cleared. |
| 16–31 RXDATA | Received Data. The RXDATA field contains the SPI data from the RX FIFO entry pointed to by the Pop Next Data Pointer. |

25.3.2.8 DSPI Transmit FIFO Registers 0–3 (DSPI_TXFR0–DSPI_TXFR3)

The DSPI_TXFR0 - DSPI_TXFR3 registers provide visibility into the TX FIFO for debugging purposes. Each register is an entry in the TX FIFO. The registers are read-only and cannot be modified. Reading the DSPI_TXFRx registers does not alter the state of the TX FIFO. The number of registers used to implement the TX FIFO is four for this device

Address: DSPI_BASE+0x3C–DSPI_BASE+0x78

Access: Read Only

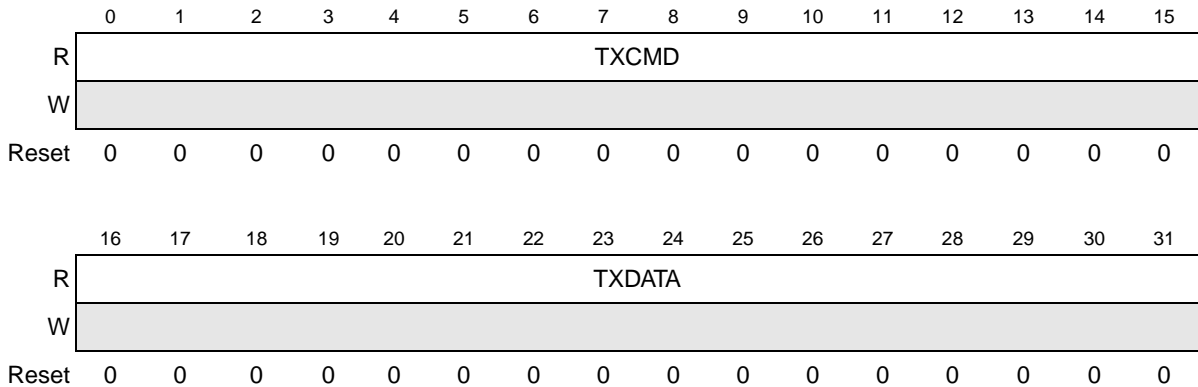

Figure 25-10. DSPI Transmit FIFO Register 0–15 (DSPI_TXFR0–DSPI_TXFR15)

Table 25-18. DSPI_TXFR n Field Descriptions

| Field | Description |
|-----------------|--|
| 0–15 TXCMD | Transmit Command. The TXCMD field contains the command that sets the transfer attributes for the SPI data. See Section 25.3.2.6, DSPI PUSH TX FIFO Register (DSPI_PUSHR) , for details on the command field. |
| 16–31 TXDATA | Transmit Data. The TXDATA field contains the SPI data to be shifted out. |

25.3.2.9 DSPI Receive FIFO Registers 0–3 (DSPI_RXFR0–DSPI_RXFR3)

The DSPI_RXFR0 - DSPI_RXFR3 registers provide visibility into the RX FIFO for debugging purposes. Each register is an entry in the RX FIFO. The DSPI_RXFR registers are read-only. Reading the DSPI_RXFR x registers does not alter the state of the RX FIFO. The number of registers used to implement the RX FIFO is four for this device.

Address: DSPI_BASE + 0x7C–DSPI_BASE + 0xB8

Access: Read Only

| | | | | | | | | | | | | | | | | |
|-------|--------|----|----|----|----|----|----|----|----|----|----|----|----|----|----|----|
| | 0 | 1 | 2 | 3 | 4 | 5 | 6 | 7 | 8 | 9 | 10 | 11 | 12 | 13 | 14 | 15 |
| R | 0 | 0 | 0 | 0 | 0 | 0 | 0 | 0 | 0 | 0 | 0 | 0 | 0 | 0 | 0 | 0 |
| W | | | | | | | | | | | | | | | | |
| Reset | 0 | 0 | 0 | 0 | 0 | 0 | 0 | 0 | 0 | 0 | 0 | 0 | 0 | 0 | 0 | 0 |
| | 16 | 17 | 18 | 19 | 20 | 21 | 22 | 23 | 24 | 25 | 26 | 27 | 28 | 29 | 30 | 31 |
| R | RXDATA | | | | | | | | | | | | | | | |
| W | | | | | | | | | | | | | | | | |
| Reset | 0 | 0 | 0 | 0 | 0 | 0 | 0 | 0 | 0 | 0 | 0 | 0 | 0 | 0 | 0 | 0 |

Figure 25-11. DSPI Receive FIFO Registers 0–15 (DSPI_RXFR0–DSPI_RXFR15)
Table 25-19. DSPI_RXFR n Field Descriptions

| Field | Description |
|-----------------|--|
| 0–15 | Reserved, should be cleared. |
| 16–31 RXDATA | Receive Data. The RXDATA field contains the received SPI data. |

25.3.2.10 DSPI DSI Configuration Register (DSPI_DSICR)

The DSI Configuration Register selects various attributes associated with DSI and CSI Configurations. The user must not write to the DSPI_DSICR while the DSPI is in the Running state.

Address: DSPI_BASE + 0xBC

Access: R/W

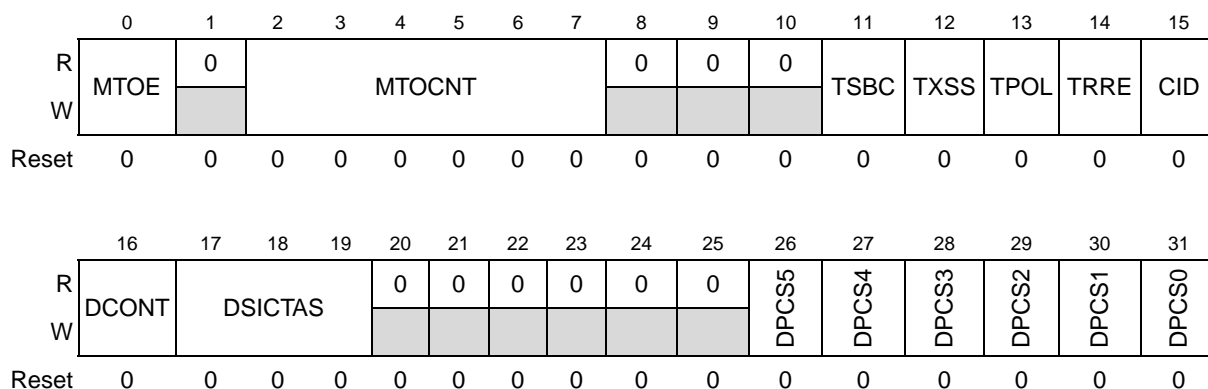

Figure 25-12. DSPI DSI Configuration Register (DSPI_DSICR)

Table 25-20. DSPI_DSICR Field Descriptions

| Field | Description |
|---------------|---|
| 0 MTOE | Multiple Transfer Operation Enable. The MTOE bit enables multiple DSPIs to be connected in a parallel or serial configuration. See Section 25.4.4.6, Multiple Transfer Operation (MTO) , for more information. 0 Multiple Transfer Operation disabled 1 Multiple Transfer Operation enabled The MTOE feature is not supported in TSB configuration and should be disabled in this mode. |
| 1 | Reserved, should be cleared. |
| 2–7 MTOCNT | Multiple Transfer Operation Count. The MTOCNT field selects number of bits to be shifted out during a transfer in Multiple Transfer Operation. The field sets the number of SCK cycles that the bus Master will generate to complete the transfer. The number of SCK cycles used will be one more than the value in the MTOCNT field. The number of SCK cycles defined by MTOCNT must be equal to or greater than the frame size. When TSBC is set, MTOCNT is not used, and its value is ignored. |
| 8–10 | Reserved, should be cleared. |
| 11 TSBC | Timed Serial Bus Configuration. The TSBC bit enables the Timed Serial Bus Configuration. This configuration allows 32-bit data to be used. It also allows t_{DT} to be programmable. See Section 25.4.9, Timed Serial Bus (TSB) , for detailed information. 0 Timed Serial Bus Configuration disabled 1 Timed Serial Bus Configuration enabled If this bit is 0 the DSPI_DSICR1 register should not be used. |
| 12 TXSS | Transmit Data Source Select. The TXSS bit selects the source of data to be serialized. The source can be either data from host Software written to the DSPI DSI Alternate Serialization Data Register (DSPI_ASDR), or Parallel Input pin states latched into the DSPI DSI Serialization Data Register (DSPI_SDR). 0 Source of serialized data is the DSPI_SDR 1 Source of serialized data is the DSPI_ASDR |
| 13 TPOL | Trigger Polarity. The TPOL bit selects the active edge of the hardware trigger input signal (HT). The bit selects which edge will initiate a transfer in the DSI configuration. See Section 25.4.4.5, DSI Transfer Initiation Control , for more information. When TSBC bit is set, bits TPOL bit is used for both DSICR and DSICR1 registers. 0 Falling edge will initiate a transfer 1 Rising edge will initiate a transfer |

Table 25-20. DSPI_DSICR Field Descriptions (continued)

| Field | Description | | | | | | | | | | | | | | | | | | | | |
|------------------|--|---------|---|---------|---|-----|------------|-----|------------|-----|------------|-----|------------|-----|------------|-----|------------|-----|------------|-----|------------|
| 14 TRRE | Trigger Reception Enable. The TRRE bit enables the DSPI to initiate a transfer when an external trigger signal is received. The bit is only valid in DSI configuration. See Section 25.4.4.5, DSI Transfer Initiation Control , for more information. When TSBC bit is set, TRRE bit is used for both DSICR and DSICR1 registers. 0 Trigger signal reception disabled 1 Trigger signal reception enabled | | | | | | | | | | | | | | | | | | | | |
| 15 CID | Change In Data Transfer Enable. The CID bit enables a change in serialization data to initiate a transfer. The bit is used in Master Mode in DSI and CSI configurations to control when to initiate transfers. When the CID bit is set, serialization is initiated when the current DSI data differs from the previous DSI data shifted out. The DSPI_COMPR register is compared with the DSPI_SDR or DSPI_AS DR register to detect a change in data. Refer to Section 25.4.4.5, DSI Transfer Initiation Control , for more information. When TSBC bit is set, CID bit is used for both DSICR and DSICR1 registers. | | | | | | | | | | | | | | | | | | | | |
| 16 DCONT | DSI Continuous Peripheral Chip Select Enable. The DCONT bit enables the PCS signals to remain asserted between transfers. The DCONT bit only affects the PCS signals in DSI Master Mode. See Section 25.4.7.5, Continuous Selection Format , for details. When TSBC bit is set, DCONT bit is used for both DSICR and DSICR1 registers. 0 Return Peripheral Chip Select signals to their inactive state after transfer is complete 1 Keep Peripheral Chip Select signals asserted after transfer is complete | | | | | | | | | | | | | | | | | | | | |
| 17–19 DSICTAS | DSI Clock and Transfer Attributes Select. The DSICTAS field selects which of the DSPI_CTAR register is used to provide transfer attributes in DSI configuration. The DSICTAS field is used in DSI Master Mode. In DSI Slave Mode, the DSPI_CTAR1 is always selected. The table below shows how the DSICTAS values map to the DSPI_CTAR registers. When TSB configuration is selected the DSICTAS bits control all 32 bits. <table border="1" style="margin: 10px auto;"> <thead> <tr> <th>DSICTAS</th> <th>DSI Clock and Transfer Attributes Controlled by</th> <th>DSICTAS</th> <th>DSI Clock and Transfer Attributes Controlled by</th> </tr> </thead> <tbody> <tr> <td>000</td> <td>DSPI_CTAR0</td> <td>100</td> <td>DSPI_CTAR4</td> </tr> <tr> <td>001</td> <td>DSPI_CTAR1</td> <td>101</td> <td>DSPI_CTAR5</td> </tr> <tr> <td>010</td> <td>DSPI_CTAR2</td> <td>110</td> <td>DSPI_CTAR6</td> </tr> <tr> <td>011</td> <td>DSPI_CTAR3</td> <td>111</td> <td>DSPI_CTAR7</td> </tr> </tbody> </table> | DSICTAS | DSI Clock and Transfer Attributes Controlled by | DSICTAS | DSI Clock and Transfer Attributes Controlled by | 000 | DSPI_CTAR0 | 100 | DSPI_CTAR4 | 001 | DSPI_CTAR1 | 101 | DSPI_CTAR5 | 010 | DSPI_CTAR2 | 110 | DSPI_CTAR6 | 011 | DSPI_CTAR3 | 111 | DSPI_CTAR7 |
| DSICTAS | DSI Clock and Transfer Attributes Controlled by | DSICTAS | DSI Clock and Transfer Attributes Controlled by | | | | | | | | | | | | | | | | | | |
| 000 | DSPI_CTAR0 | 100 | DSPI_CTAR4 | | | | | | | | | | | | | | | | | | |
| 001 | DSPI_CTAR1 | 101 | DSPI_CTAR5 | | | | | | | | | | | | | | | | | | |
| 010 | DSPI_CTAR2 | 110 | DSPI_CTAR6 | | | | | | | | | | | | | | | | | | |
| 011 | DSPI_CTAR3 | 111 | DSPI_CTAR7 | | | | | | | | | | | | | | | | | | |
| 20–25 | Reserved, should be cleared. | | | | | | | | | | | | | | | | | | | | |
| 26–31 DPCSx | DSI Peripheral Chip Select 0–7. The DPCS bits select which of the PCS signals to assert during a DSI transfer. The DPCS bits only control the assertions of the PCS signals in DSI Master Mode. 0 Negate PCS[x] 1 Assert PCS[x] | | | | | | | | | | | | | | | | | | | | |

25.3.2.11 DSPI DSI Serialization Data Register (DSPI_SDR)

The DSPI_SDR contains the signal states of the Parallel Input signals. The pin states of the Parallel Input signals are latched into the DSPI_SDR on the rising edge of every system clock. The DSPI_SDR is read-only. When the TXSS bit in the DSPI_DSICR is negated, the data in the DSPI_SDR is the source of the serialized data.

The DSPI_SDR is a 32-bit register. All 32 bits are used in TSB configuration and only the least significant 16 bits are used in all other configurations.

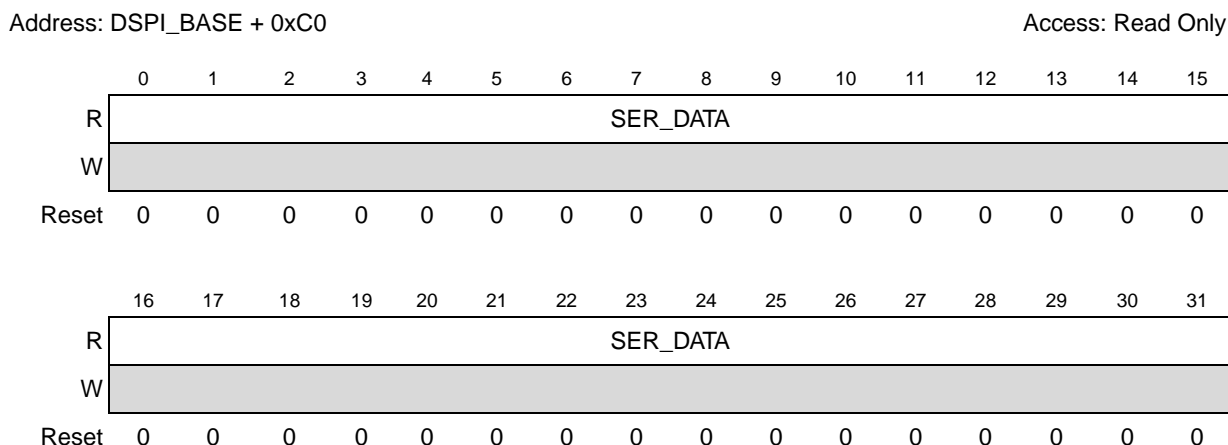

Figure 25-13. DSPI DSI Serialization Data Register (DSPI_SDR)

Table 25-21. DSPI_SDR Field Descriptions

| Field | Description |
|------------------|---|
| 0–31 SER_DATA | Serialized Data. The SER_DATA field contains the signal states of the Parallel Input signals. |

25.3.2.12 DSPI DSI Alternate Serialization Data Register (DSPI_ASDR)

The DSPI_ASDR provides a means for host software to write the data to be serialized. When the TXSS bit in the DSPI_DSICR is set, the data in the DSPI_ASDR is the source of the serialized data. Writes to the DSPI_ASDR take effect on the next frame boundary.

The DSPI_ASDR is a 32 bits register, the upper 16 bits are only used, when TSB is enabled. For non TSB configurations only the least 16 significant bits are used.

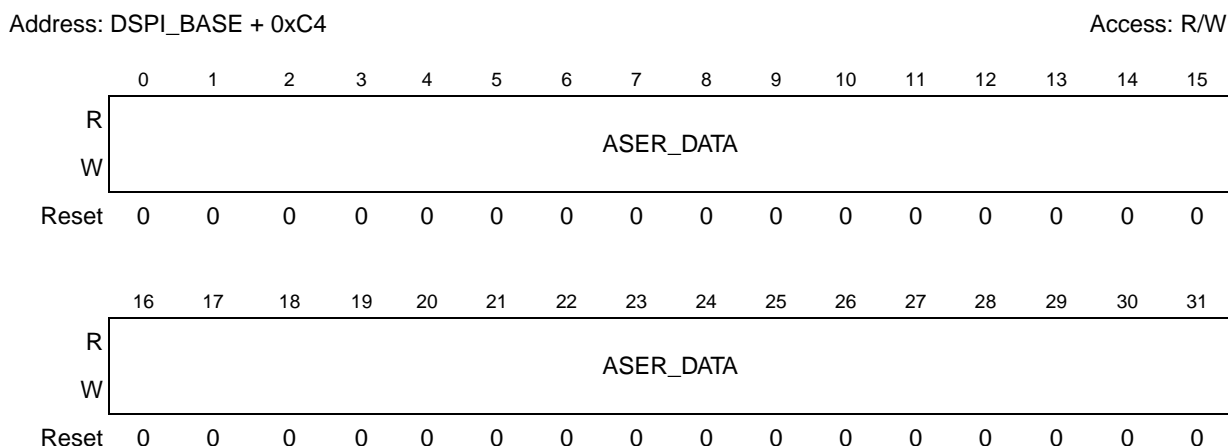

Figure 25-14. DSPI DSI Alternate Serialization Data Register (DSPI_ASDR)

Table 25-22. DSPI_ASDR Field Descriptions

| Field | Descriptions |
|-------------------|---|
| 0–31 ASER_DATA | Alternate Serialized Data. The ASER_DATA field holds the alternate data to be serialized. |

25.3.2.13 DSPI DSI Transmit Comparison Register (DSPI_COMPR)

The DSPI_COMPR holds a copy of the last transmitted DSI data. The DSPI_COMPR is read-only. DSI data is transferred to this register as it is loaded into the TX Shift Register.

The DSPI_COMPR is a 32 bits register, the upper 16 bits are only used, when TSB is enabled. For non TSB configurations only the least 16 significant bits are used.

Address: DSPI_BASE + 0xC8

Access: Read Only

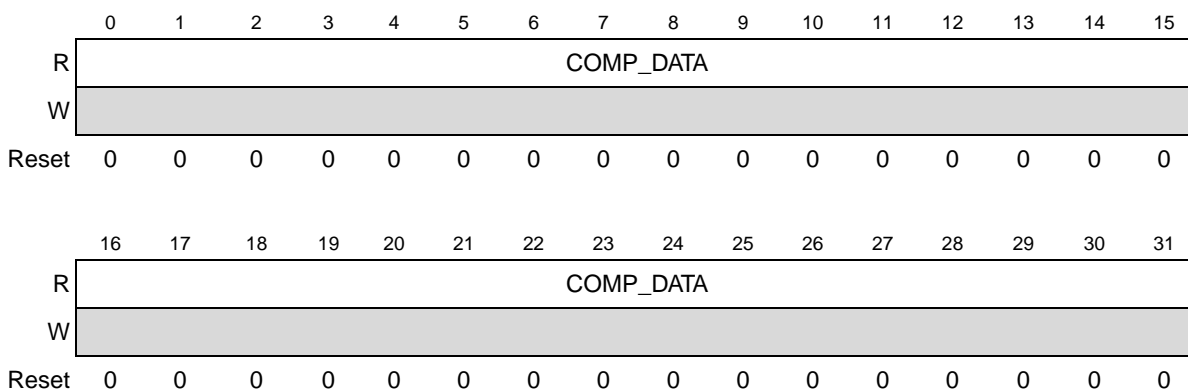
Figure 25-15. DSPI DSI Transmit Comparison Register (DSPI_COMPR)
Table 25-23. DSPI_COMPR Field Descriptions

| Field | Description |
|-------------------|---|
| 0–31 COMP_DATA | Compare Data. The COMP_DATA field holds the last serialized DSI data. |

25.3.2.14 DSPI DSI Deserialization Data Register (DSPI_DDR)

The DSPI_DDR register holds the signal states for the Parallel Output signals. The DSPI_DDR is read-only and it is memory mapped so that host software can read the incoming DSI frames.

Address: DSPI_BASE + 0xCC Access: Read Only

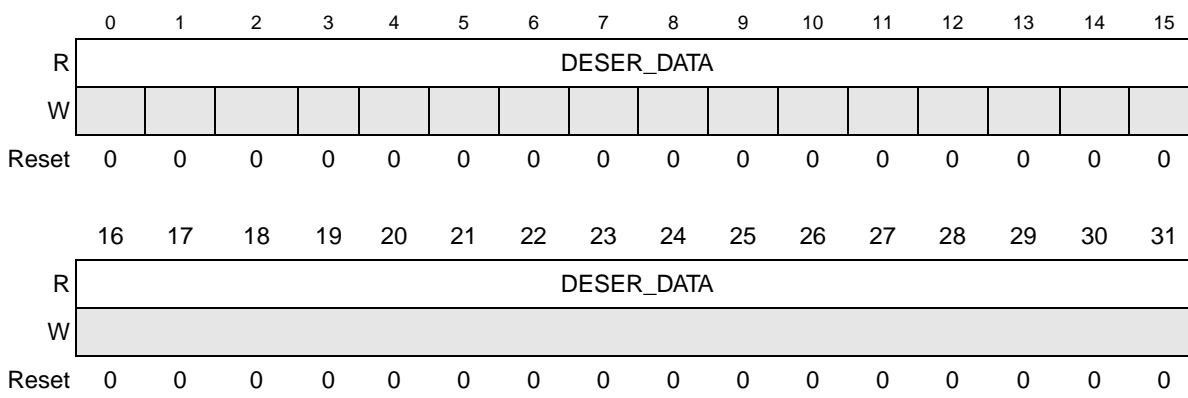

Figure 25-16. DSPI Deserialization Data Register (DSPI_DDR)

Table 25-24. DSPI_DDR Field Descriptions

| Field | Descriptions |
|-------------------------|---|
| 0–15 DESER_DAT A | Deserialized Data. When TSB configuration is set, the DESER_DATA field holds deserialized data which is presented as signal states to the Parallel Output signals. If TSB is disabled these bits are ignored, and only the lower 16 bits are valid. |
| 16–31 DESER_DAT A | Deserialized Data. The DESER_DATA field holds deserialized data which is presented as signal states to the Parallel Output signals. |

25.3.2.15 DSPI DSI Configuration Register 1 (DSPI_DSICR1)

The DSI Configuration Register 1 selects various attributes associated with TSB Configuration. The user must not write to the DSPI_DSICR1 while the DSPI is in the Running state. If TSB configuration is not used the register value is ignored.

Address: DSPI_BASE + 0xD0 Access: R/W

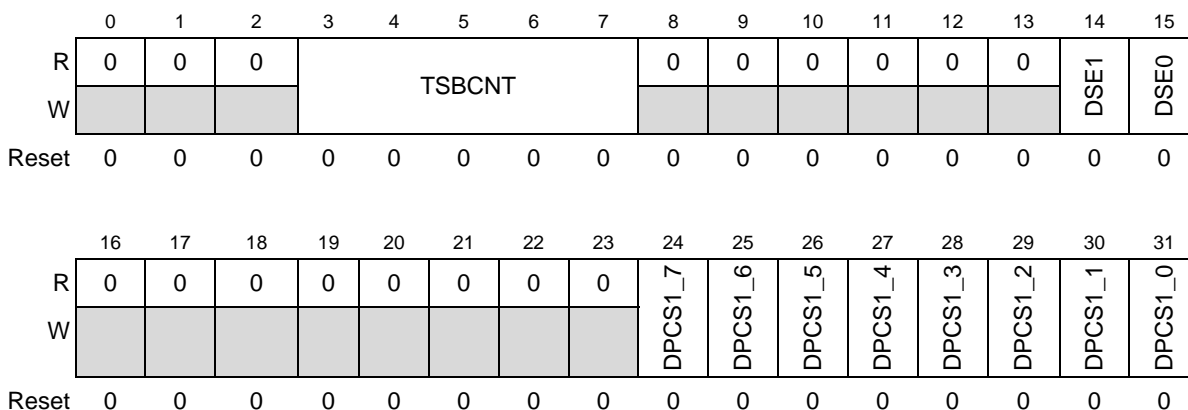

Figure 25-17. DSPI DSI Configuration Register 1 (DSPI_DSICR1)

Table 25-25. DSPI_SDR Field Descriptions

| Field | Description | | | | | | | | | | | | | | | | | | |
|------------------|--|--------|-----------|-------|----------|-------|----------|-------|----------|-------|---|-------|---|-------|---|-----|-----|-------|----|
| 0–2 | Reserved, should be cleared. | | | | | | | | | | | | | | | | | | |
| 3–7 TSBCNT | <p>Timed Serial Bus Operation Count. When TSBC is set, TSBCNT defines the length of the TSB frame. A number between 4 and 32.</p> <p>The TSBCNT field selects number of bits to be shifted out during a transfer in TSB Operation. The field sets the number of SCK cycles that the bus Master will generate to complete the transfer. The number of SCK cycles used will be one more than the value in the TSBCNT field. The number of SCK cycles defined by TSBCNT must be equal to or greater than the frame size.</p> <table border="1" style="margin-left: auto; margin-right: auto;"> <thead> <tr> <th>TSBCNT</th> <th>Framesize</th> </tr> </thead> <tbody> <tr> <td>00000</td> <td>Reserved</td> </tr> <tr> <td>00001</td> <td>Reserved</td> </tr> <tr> <td>00010</td> <td>Reserved</td> </tr> <tr> <td>00011</td> <td>4</td> </tr> <tr> <td>00100</td> <td>5</td> </tr> <tr> <td>00101</td> <td>6</td> </tr> <tr> <td>...</td> <td>...</td> </tr> <tr> <td>11111</td> <td>32</td> </tr> </tbody> </table> | TSBCNT | Framesize | 00000 | Reserved | 00001 | Reserved | 00010 | Reserved | 00011 | 4 | 00100 | 5 | 00101 | 6 | ... | ... | 11111 | 32 |
| TSBCNT | Framesize | | | | | | | | | | | | | | | | | | |
| 00000 | Reserved | | | | | | | | | | | | | | | | | | |
| 00001 | Reserved | | | | | | | | | | | | | | | | | | |
| 00010 | Reserved | | | | | | | | | | | | | | | | | | |
| 00011 | 4 | | | | | | | | | | | | | | | | | | |
| 00100 | 5 | | | | | | | | | | | | | | | | | | |
| 00101 | 6 | | | | | | | | | | | | | | | | | | |
| ... | ... | | | | | | | | | | | | | | | | | | |
| 11111 | 32 | | | | | | | | | | | | | | | | | | |
| 8–13 | Reserved, should be cleared. | | | | | | | | | | | | | | | | | | |
| 14 DSE1 | <p>Data Select Enable1. When TBSC bit is set, the DSE1 bit controls insertion of the zero bit (Data Select) in the middle of the data frame. The insertion bit position is defined by FMSZ field of DSPI_CTARn register, selected by DSICTAS field of the DSPI_DSICR register.</p> <p>0 No Zero bit inserted in the middle of the data frame. 1 Zero bit is inserted at the middle of the data frame. Total number of bits in the data frame is increased by 1.</p> | | | | | | | | | | | | | | | | | | |
| 15 DSE0 | <p>Data Select Enable0. When TBSC bit is set, the DSE0 bit controls insertion of the zero bit (Data Select) in the beginning of the data frame.</p> <p>0 No Zero bit inserted in the beginning of the frame 1 Zero bit is inserted at the beginning of the data frame. Total number of bits in the data frame is increased by 1.</p> | | | | | | | | | | | | | | | | | | |
| 16–23 | Reserved, should be cleared. | | | | | | | | | | | | | | | | | | |
| 24–31 DPCS1_x | <p>DSI Peripheral Chip Select 0–7. These bits define the CS to assert for the second part of the DSI frame when operating in TSB configuration with dual receiver. The DPCS1 bits select which of the PCS signals to assert during the second DSI transfer. The DPCS1 bits only control the assertions of the PCS signals in DSI Master Mode when in TSB configuration.</p> <p>0 Negate PCS[x] 1 Assert PCS[x]</p> | | | | | | | | | | | | | | | | | | |

25.4 Functional Description

The Deserial Serial Peripheral Interface (DSPI) block supports full-duplex, synchronous serial communications between MCUs and peripheral devices. The DSPI can also be used to reduce the number of pins required for I/O by serializing and deserializing up to 16 Parallel Input/Output signals. All

communications are through a SPI-like protocol. Specifically in the TSB configuration, the DSPI can serialize up to 32 Parallel Input signals or 32 registered bits.

The DSPI has three configurations:

- SPI Configuration in which the DSPI operates as a basic SPI or a queued SPI.
- DSI Configuration in which the DSPI serializes and deserializes Parallel Input/Output signals or bits from memory mapped registers.
- CSI Configuration in which the DSPI combines the functionality of the SPI and DSI configurations.

The DCONF field in the DSPI Module Configuration Register (DSPI_MCR) determines the DSPI Configuration. See [Table 25-5](#) for the DSPI configuration values.

The DSPI_CTAR0 - DSPI_CTAR7 registers hold clock and transfer attributes. The SPI configuration can select which CTAR to use on a frame by frame basis by setting a field in the SPI command. The DSI configuration statically selects which CTAR to use. In CSI Configuration priority logic determines if SPI data or DSI data is transferred. The type of data transferred dictates which CTAR register the CSI configuration will use. See [Section 25.3.2.3, DSPI Clock and Transfer Attributes Registers 0–7 \(DSPI_CTAR0–DSPI_CTAR7\)](#), for information on the fields of the DSPI_CTAR registers.

The 16-bit shift register in the Master and the 16-bit shift register in the Slave are linked by the SOUT and SIN signals to form a distributed 32-bit register. The Master and Slave use 16-bit shift registers regardless the TSBC bit is asserted in the DSPI_DSICR register. When a data transfer operation is performed, data is serially shifted a predetermined number of bit positions. Because the registers are linked, data is exchanged between the Master and the Slave; the data that was in the Master’s shift register is now in the shift register of the Slave, and vice versa. At the end of a transfer, the TCF bit in the DSPI_SR is set to indicate a completed transfer. [Figure 25-18](#) illustrates how Master and Slave data is exchanged.

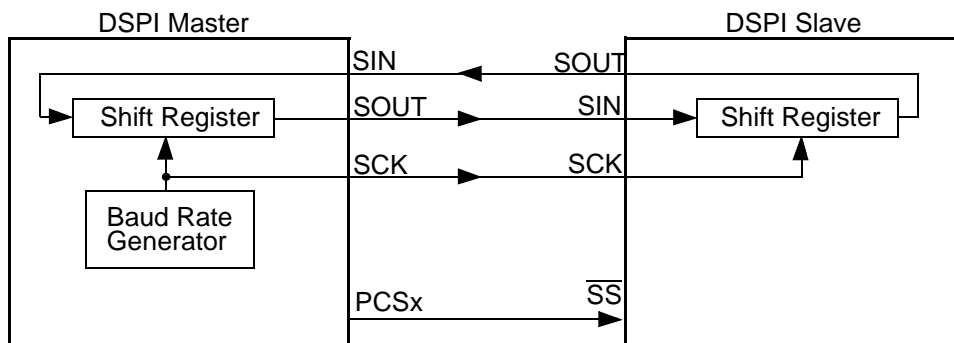

Figure 25-18. SPI and DSI Serial Protocol Overview

The DSPI has eight Peripheral Chip Select (PCS) signals that are used to select which of the Slaves to communicate with.

The three DSPI configurations share transfer protocol and timing properties so they are described independently of the configuration in [Section 25.4.7, Transfer Formats](#). The transfer rate and delay settings are described in [Section 25.4.6, DSPI Baud Rate and Clock Delay Generation](#).

See [Section 25.4.11, Power Saving Features](#), for information on the power-saving features of the DSPI.

25.4.1 Modes of Operation

The DSPI has these distinct modes:

- Master Mode
- Slave Mode
- Module Disable Mode
- External Stop Mode
- Debug Mode

Master, Slave, and Module Disable Modes are block-specific modes while External Stop and Debug Modes are MCU-specific modes.

The block-specific modes are determined by bits in the DSPI_MCR register. External Stop Mode and Debug Mode are modes that the entire MCU can enter in parallel with the DSPI being configured in one of its block-specific modes.

25.4.1.1 Master Mode

In Master Mode the DSPI can initiate communications with peripheral devices. The DSPI operates as bus master when the MSTR bit in the DSPI_MCR register is set. The Serial Communications Clock (SCK) is controlled by the Master DSPI. All three DSPI configurations are valid in Master Mode.

In SPI Configuration, Master Mode transfer attributes are controlled by the SPI command in the current TX FIFO entry. The CTAS field in the SPI command selects which of the eight DSPI_CTAR registers will be used to set the transfer attributes. Transfer attribute control is on a frame by frame basis. See [Section 25.4.3, Serial Peripheral Interface \(SPI\) Configuration](#), for more details.

In DSI Configuration, Master Mode transfer attributes are controlled by the DSPI DSI Configuration Register (DSPI_DSICR). The DSISCTAS field in the DSPI_DSICR selects which of the DSPI_CTAR registers will be used to set the transfer attributes. Transfer attributes are set up during initialization and should not be changed between frames. See [Section 25.4.4, Deserial Serial Interface \(DSI\) Configuration](#), for more details.

In CSI Configuration, the DSI data is transferred using DSI Configuration transfer attributes and SPI data is transferred using the SPI Configuration transfer attributes. In order for the bus slave to distinguish between DSI and SPI frames, the transfer attributes for the two types of frames must utilize different Peripheral Chip Select signals. See [Section 25.4.5, Combined Serial Interface \(CSI\) Configuration](#), for details.

25.4.1.2 Slave Mode

In Slave Mode the DSPI responds to transfers initiated by a SPI master. The DSPI operates as bus slave when the MSTR bit in the DSPI_MCR is negated. The DSPI slave is selected by a bus master by having the slave's SS asserted. In Slave Mode the SCK is provided by the bus master. All transfer attributes are controlled by the bus master but clock polarity, clock phase and numbers of bits to transfer must still be configured in the DSPI slave for proper communications.

The SPI and DSI configurations are valid in Slave Mode. In SPI Slave Mode the slave transfer attributes are set in the DSPI_CTAR0. In DSI Slave Mode the slave transfer attributes are set in the DSPI_CTAR1. In both SPI and DSI configurations the DSPI in Slave Mode transfers data MSB first. The LSBFE field of the associated CTAR is ignored.

25.4.1.3 Module Disable Mode

The Module Disable Mode is used for MCU power management. The clock to the non-memory mapped logic in the DSPI can be stopped while in Module Disable Mode. The DSPI enters the Module Disable Mode when the MDIS bit in DSPI_MCR is set or when a request for the DSPI to enter Doze Mode is asserted by an external controller while the DOZE bit in the DSPI_MCR is asserted. Logic external to the DSPI is needed to implement the Module Disable Mode. See [Section 25.4.11, Power Saving Features](#), for more details on the Module Disable Mode.

25.4.1.4 External Stop Mode

For devices with low-power modes, the DSPI supports the Stop Mode mechanism. The DSPI will not acknowledge the request to enter External Stop Mode until it has reached a frame boundary. When the DSPI has reached a frame boundary it will halt all operations and indicate that it is ready to have its clocks shut off. The DSPI exits External Stop Mode and resumes normal operation once the clocks are turned on. Serial communications or register accesses made while in External Stop Mode are ignored even if the clocks have not been shut off yet. See [Section 25.4.11, Power Saving Features](#), for more details on the External Stop Mode.

25.4.1.5 Debug Mode

The Debug Mode is used for system development and debugging. If the device enters Debug Mode while the FRZ bit in the DSPI_MCR is set, the DSPI stops all serial transfers and enters a stopped state. If the device enters Debug Mode while the FRZ bit is negated, the DSPI behavior is unaffected and remains dictated by the block-specific mode and configuration of the DSPI. The DSPI enters Debug Mode when a debug request is asserted by an external controller. See [Figure 25-19](#) for a state diagram.

25.4.2 Start and Stop of DSPI Transfers

The DSPI has two operating states; STOPPED and RUNNING. The states are independent of DSPI configuration. The default state of the DSPI is STOPPED. In the STOPPED state no serial transfers are initiated in Master Mode and no transfers are responded to in Slave Mode. The STOPPED state is also a safe state for writing the various configuration registers of the DSPI without causing undetermined results. The TXRXS bit in the DSPI_SR is negated in this state. In the RUNNING state serial transfers take place. The TXRXS bit in the DSPI_SR is asserted in the RUNNING state. [Figure 25-19](#) shows a state diagram of the start and stop mechanism. The transitions are described in [Table 25-26](#).

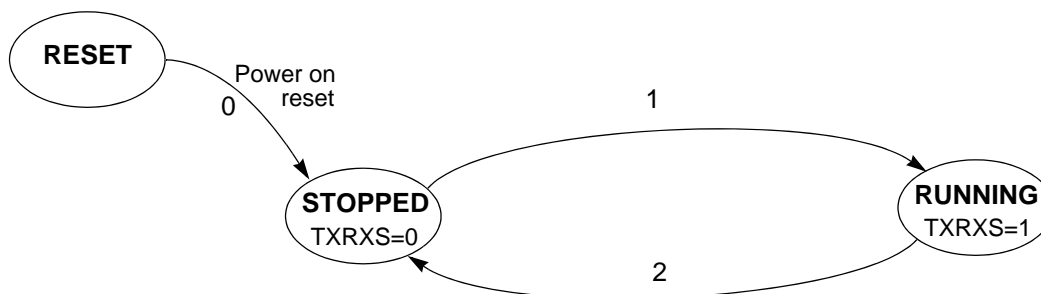

Figure 25-19. DSPI Start and Stop State Diagram

Table 25-26. State Transitions for Start and Stop of DSPI Transfers

| Transition # | Current State | Next State | Description |
|--------------|---------------|------------|---|
| 0 | RESET | STOPPED | Generic power-on-reset transition |
| 1 | STOPPED | RUNNING | The DSPI is started (DSPI transitions to RUNNING) when all of the following conditions are true: <ul style="list-style-type: none"> • EOQF bit is clear • Debug mode is unselected or the FRZ bit is clear • HALT bit is clear |
| 2 | RUNNING | STOPPED | The DSPI stops (transitions from RUNNING to STOPPED) after the current frame for any one of the following conditions: <ul style="list-style-type: none"> • EOQF bit is set • Debug mode is selected and the FRZ bit is set • HALT bit is set |

State transitions from RUNNING to STOPPED occur on the next frame boundary if a transfer is in progress, or on the next system clock cycle if no transfers are in progress.

25.4.3 Serial Peripheral Interface (SPI) Configuration

The SPI Configuration transfers data serially using a shift register and a selection of programmable transfer attributes. The DSPI is in SPI Configuration when the DCONF field in the DSPI_MCR is 0b00. The SPI frames can be from four to sixteen bits long. The data to be transmitted can come from queues stored in RAM external to the DSPI. Host software or a DMA Controller can transfer the SPI data from the queues to a First-In First-Out (FIFO) buffer. The received data is stored in entries in the Receive FIFO (RX FIFO) buffer. Host software or a DMA Controller transfer the received data from the RX FIFO to memory external to the DSPI. The FIFO buffer operations are described in [Section 25.4.3.4, Transmit First In First Out \(TX FIFO\) Buffering Mechanism](#), and [Section 25.4.3.5, Receive First In First Out \(RX FIFO\) Buffering Mechanism](#). The interrupt and DMA request conditions are described in [Section 25.4.10, Interrupts/DMA Requests](#).

The SPI Configuration supports two block-specific modes; Master Mode and Slave Mode. The FIFO operations are similar for the Master Mode and Slave Mode. The main difference is that in Master Mode the DSPI initiates and controls the transfer according to the fields in the SPI command field of the TX FIFO

entry. In Slave mode the DSPI only responds to transfers initiated by a bus master external to the DSPI and the SPI command field of the TX FIFO entry is ignored.

25.4.3.1 Master Mode

In SPI Master Mode the DSPI initiates the serial transfers by controlling the Serial Communications Clock (SCK) and the Peripheral Chip Select (PCS) signals. The SPI command field in the executing TX FIFO entry determines which CTAR registers will be used to set the transfer attributes and which PCS signal to assert. The command field also contains various bits that help with queue management and transfer protocol. See [Section 25.3.2.6, DSPI PUSH TX FIFO Register \(DSPI_PUSHR\)](#), for details on the SPI command fields. The data field in the executing TX FIFO entry is loaded into the shift register and shifted out on the Serial Out (SOUT) pin. In SPI Master Mode, each SPI frame to be transmitted has a command associated with it allowing for transfer attribute control on a frame by frame basis.

25.4.3.2 Slave Mode

In SPI Slave Mode the DSPI responds to transfers initiated by a SPI bus master. The DSPI does not initiate transfers. Certain transfer attributes such as clock polarity, clock phase and frame size must be set for successful communication with a SPI master. The SPI Slave Mode transfer attributes are set in the DSPI_CTAR0.

25.4.3.3 FIFO Disable Operation

The FIFO disable mechanisms allow SPI transfers without using the TX FIFO or RX FIFO. The DSPI operates as a double-buffered simplified SPI when the FIFOs are disabled. The TX and RX FIFOs are disabled separately. The TX FIFO is disabled by writing a '1' to the DIS_TXF bit in the DSPI_MCR. The RX FIFO is disabled by writing a '1' to the DIS_RXF bit in the DSPI_MCR.

The FIFO Disable mechanisms are transparent to the user and to host software; Transmit data and commands are written to the DSPI_PUSHR and received data is read from the DSPI_POPR. When the TX FIFO is disabled the TFFF, TFUF and TXCTR fields in DSPI_SR behave as if there is a one-entry FIFO but the contents of the DSPI_TXFR registers and TXNXTPTR are undefined. When the RX FIFO is disabled the RFDF, RFOF and RXCTR fields in the DSPI_SR behave as if there is a one-entry FIFO but the contents of the DSPI_RXFR registers and POPNXTPTR are undefined.

25.4.3.4 Transmit First In First Out (TX FIFO) Buffering Mechanism

The TX FIFO functions as a buffer of SPI data and SPI commands for transmission. The TX FIFO holds four words, each consisting of a command field and a data field. SPI commands and data are added to the TX FIFO by writing to the DSPI PUSH TX FIFO Register (DSPI_PUSHR). TX FIFO entries can only be removed from the TX FIFO by being shifted out or by flushing the TX FIFO.

The TX FIFO Counter field (TXCTR) in the DSPI Status Register (DSPI_SR) indicates the number of valid entries in the TX FIFO. The TXCTR is updated every time the DSPI_PUSHR is written or SPI data is transferred into the shift register from the TX FIFO.

The TXNXTPTR field indicates which TX FIFO Entry will be transmitted during the next transfer. The TXNXTPTR contains the positive offset from DSPI_TXFR0 in number of 32-bit registers. For example,

TXNXTPTR equal to two means that the DSPI_TXFR2 contains the SPI data and command for the next transfer. The TXNXTPTR field is incremented every time SPI data is transferred from the TX FIFO to the shift register.

25.4.3.4.1 Filling the TX FIFO

Host software or other intelligent blocks can add (push) entries to the TX FIFO by writing to the DSPI_PUSHR. When the TX FIFO is not full, the TX FIFO Fill Flag (TFFF) in the DSPI_SR is set. The TFFF bit is cleared when TX FIFO is full and the DMA controller indicates that a write to DSPI_PUSHR is complete or by host software writing a '1' to the TFFF in the DSPI_SR. The TFFF can generate a DMA request or an interrupt request. See [Section 25.4.10.2, Transmit FIFO Fill Interrupt or DMA Request](#), for details.

The DSPI ignores attempts to push data to a full TX FIFO, i.e. the state of the TX FIFO is unchanged. No error condition is indicated.

25.4.3.4.2 Draining the TX FIFO

The TX FIFO entries are removed (drained) by shifting SPI data out through the shift register. Entries are transferred from the TX FIFO to the shift register and shifted out as long as there are valid entries in the TX FIFO. Every time an entry is transferred from the TX FIFO to the shift register, the TX FIFO Counter is decremented by one. At the end of a transfer, the TCF bit in the DSPI_SR is set to indicate the completion of a transfer. The TX FIFO is flushed by writing a '1' to the CLR_TXF bit in DSPI_MCR.

If an external bus master initiates a transfer with a DSPI slave while the slave's DSPI TX FIFO is empty, the Transmit FIFO Underflow Flag (TFUF) in the slave's DSPI_SR is set. See [Section 25.4.10.4, Transmit FIFO Underflow Interrupt Request](#), for details.

25.4.3.5 Receive First In First Out (RX FIFO) Buffering Mechanism

The RX FIFO functions as a buffer for data received on the SIN pin. The RX FIFO holds four received SPI data frames. SPI data is added to the RX FIFO at the completion of a transfer when the received data in the shift register is transferred into the RX FIFO. SPI data are removed (popped) from the RX FIFO by reading the DSPI POP RX FIFO Register (DSPI_POPR). RX FIFO entries can only be removed from the RX FIFO by reading the DSPI_POPR or by flushing the RX FIFO.

The RX FIFO Counter field (RXCTR) in the DSPI Status Register (DSPI_SR) indicates the number of valid entries in the RX FIFO. The RXCTR is updated every time the DSPI_POPR is read or SPI data is copied from the shift register to the RX FIFO.

The POPNXTPTR field in the DSPI_SR points to the RX FIFO entry that is returned when the DSPI_POPR is read. The POPNXTPTR contains the positive offset from DSPI_RXFR0 in number of 32-bit registers. For example, POPNXTPTR equal to two means that the DSPI_RXFR2 contains the received SPI data that will be returned when DSPI_POPR is read. The POPNXTPTR field is incremented every time the DSPI_POPR is read.

25.4.3.5.1 Filling the RX FIFO

The RX FIFO is filled with the received SPI data from the shift register. While the RX FIFO is not full, SPI frames from the shift register are transferred to the RX FIFO. Every time a SPI frame is transferred to the RX FIFO the RX FIFO Counter is incremented by one.

If the RX FIFO and shift register are full and a transfer is initiated, the RFOF bit in the DSPI_SR is asserted indicating an overflow condition. Depending on the state of the ROOE bit in the DSPI_MCR, the data from the transfer that generated the overflow is either ignored or shifted in to the shift register. If the ROOE bit is asserted, the incoming data is shifted in to the shift register. If the ROOE bit is negated, the incoming data is ignored.

25.4.3.5.2 Draining the RX FIFO

Host software or other intelligent blocks can remove (pop) entries from the RX FIFO by reading the DSPI POP RX FIFO Register (DSPI_POPR). A read of the DSPI_POPR decrements the RX FIFO Counter by one. Attempts to pop data from an empty RX FIFO are ignored, the RX FIFO Counter remains unchanged. The data returned from reading an empty RX FIFO is undetermined.

When the RX FIFO is not empty, the RX FIFO Drain Flag (RFDF) in the DSPI_SR is set. The RFDF bit is cleared when the RX_FIFO is empty and the DMA controller indicates that a read from DSPI_POPR is complete or by host software writing a '1' to the RFDF.

25.4.4 Deserial Serial Interface (DSI) Configuration

The DSI Configuration supports pin count reduction by serializing Parallel Input signals or register bits and shifting them out in a SPI-like protocol. The timing and transfer protocol is described in [Section 25.4.7, Transfer Formats](#). The received serial frames are converted to a parallel form (deserialized) and placed on the Parallel Output signals or in a register. The various features of the DSI Configuration are set in DSPI DSI Configuration Register (DSPI_DSICR). The DSPI is in DSI Configuration when the DCONF field in the DSPI_MCR is 0b01.

The DSI frames can be from four to sixteen bits long, but four to 32 bits can be used in the TSB configuration (see [Section 25.4.9, Timed Serial Bus \(TSB\)](#), for detailed information). With Multiple Transfer Operation (MTO) the DSPI supports serial chaining of DSPI blocks within a device to create DSI frames consisting of concatenated bits from multiple DSPIs. The DSPI also supports parallel chaining allowing several DSPIs and off-chip SPI devices to share the same Serial Communications Clock (SCK) and Peripheral Chip Select (PCS) signals. See [Section 25.4.4.6, Multiple Transfer Operation \(MTO\)](#), for details on the serial and parallel chaining support.

25.4.4.1 DSI Master Mode

In DSI Master Mode the DSPI initiates and controls the DSI transfers. The DSI Master has four different conditions that can initiate a transfer:

- Continuous
- Change in data
- Trigger signal

- Trigger signal combined with a change in data

The four transfer initiation conditions are described in [Section 25.4.4.5, DSI Transfer Initiation Control](#). Transfer attributes are set during initialization. The DSICTAS field in the DSPI_DSICR determines which of the DSPI_CTAR registers will control the transfer attributes.

25.4.4.2 DSI Slave Mode

In DSI Slave Mode the DSPI responds to transfers initiated by a SPI or DSI bus master. In this mode the DSPI does not initiate DSI transfers. Certain transfer attributes such as clock polarity and phase must be set for successful communication with a DSI master. The DSI Slave Mode Transfer attributes are set in the DSPI_CTAR1.

If the CID bit in the DSPI_DSICR is set and the data in the DSPI_COMPR differs from the selected source of the serialized data, the slave DSPI will assert the $\overline{\text{MTRIG}}$ signal. If the slave's HT signal is asserted and the TRRE is set, the slave DSPI asserts $\overline{\text{MTRIG}}$. These features are included to support chaining of several DSPI. Details about the $\overline{\text{MTRIG}}$ signal is found in [Section 25.4.4.6, Multiple Transfer Operation \(MTO\)](#).

25.4.4.3 DSI Serialization

In the DSI Configuration from four to sixteen bits can be serialized using two different sources. The TXSS bit in the DSPI_DSICR selects between the DSPI DSI Serialization Data Register (DSPI_SDR) and the DSPI DSI Alternate Serialization Data Register (DSPI_ASDR) as the source of the serialized data. The DSPI_SDR holds the latest Parallel Input signal values which is sampled at every rising edge of the system clock. The DSPI_ASDR register is written by host software and used as an alternate source of serialized data.

A copy of the last 32-bit DSI frame shifted out of the Shift Register is stored in the DSPI DSI Transmit Comparison Register (DSPI_COMPR). This register provides added visibility for debugging and it serves as a reference for transfer initiation control. [Figure 25-20](#) shows the DSI Serialization logic.

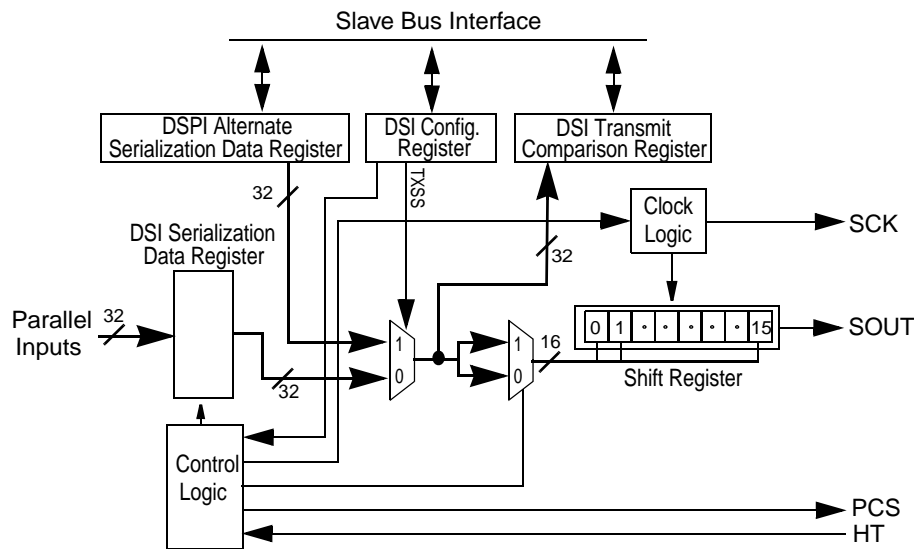
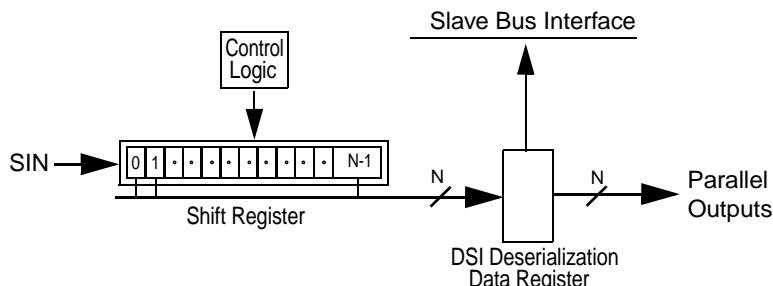

Figure 25-20. DSI Serialization Diagram

25.4.4.4 DSI Deserialization

When all bits in a DSI frame have been shifted in, the frame is copied to the DSPI DSI Deserialization Data Register (DSPI_DDR). This register presents the deserialized data as Parallel Output signal values. The DSPI_DDR is memory mapped to allow host software to read the deserialized data directly. Figure 25-21 shows the DSI Deserialization logic.



In TSB configuration the number of bits N = 32, for non TSB it values 16.

Figure 25-21. DSI Deserialization Diagram

25.4.4.5 DSI Transfer Initiation Control

Data transfers for a Master DSPI in DSI configuration are initiated by a condition. The transfer initiation conditions are selected by the TRRE and CID bits in the DSPI_DSICR. Table 25-27 lists the four transfer initiation conditions.

Table 25-27. DSI Data Transfer Initiation Control

| DSPI_DSICR Bits | | Transfer Initiation Control |
|-----------------|-----|-----------------------------|
| TRRE | CID | |
| 0 | 0 | Continuous |
| 0 | 1 | Change in Data |
| 1 | 0 | Triggered |
| 1 | 1 | Triggered or Change in Data |

25.4.4.5.1 Continuous Control

For Continuous Control the initiation of a transfer is based on the baud rate at which data is transferred between the DSPI and the external device. The baud rate is set in the DSPI_CTAR register selected by the DSICTAS field in the DSPI_DSICR. A new DSI frame shifts out when the previous transfer cycle has completed and the Delay after Transfer (t_{DT}) has elapsed.

25.4.4.5.2 Change In Data Control

For Change in Data Control a transfer is initiated when the data to be serialized has changed since the transfer of the last DSI frame. A copy of the previously transferred DSI data is stored in the DSPI_COMPR. When the data in the DSPI_SDR or the DSPI_AS DR is different from the data in the DSPI_COMPR a new DSI frame is transmitted. The TXSS bit in the DSPI_DSICR selects which register

the DSPI_COMPR is compared to. The $\overline{\text{MTRIG}}$ output signal is asserted every time a change in data is detected.

25.4.4.5.3 Triggered Control

For Triggered Control initiation of a transfer is controlled by the Hardware Trigger signal (HT). The TPOL bit in the DSPI_DSICR selects the active edge of HT. For HT to have any affect, the TRRE bit in the DSPI_DSICR must be set.

25.4.4.5.4 Triggered or Change In Data Control

For Triggered or Change in Data Control initiation of a transfer is controlled by the HT signal or by the detection of a change in data to be serialized.

25.4.4.6 Multiple Transfer Operation (MTO)

In DSI Configuration the MTO feature allows for multiple DSPIs within a device to be chained together in a parallel or serial configuration. The parallel chaining allows multiple DSPIs internal to a device and multiple SPI devices external to a device to share SCK and PCS signals thereby saving pins. The serial chaining allows bits from multiple DSPIs to be concatenated into a single DSI frame. MTO is enabled by setting the MTOE bit in the DSPI_DSICR.

In parallel and serial chaining there is one bus master and multiple bus slaves. The bus master initiates and controls the transfers, but the DSPI slaves generate trigger signals for the bus DSPI master when an internal condition in the slave warrants a transfer. The DSPI slaves also propagate triggers from other slaves to the master. When a DSPI slave detects a trigger signal on its HT input, the slave generates a trigger signal on the $\overline{\text{MTRIG}}$ output.

Serial and parallel chaining require multiplexing of signals external to the DSPI.

25.4.4.6.1 Parallel Chaining

NOTE

When using the DSPI in DSI mode, with MTO enabled, and clock phase set to leading edge capture (DSPIx_CTARn[CPHA]=0) the first bit shifted out of the master DSPI into the slave DSPI is read as “1”, regardless of the actual value. To account for this behavior, the following options are recommended:

- Select CPHA=1 (following edge capture), if suitable for external slave devices.
- Set the first bit of the transferred data to “1”, or ignore the first bit.
- Externally connect master SOUT to SIN of the first slave, rather than connecting via internal signals. This requires setting SIU_DISR_SINSELx bits of the first slave DSPI to “00” and configuring the first slave's SIN pin and master SOUT pin as DSPI SIN and DSPI SOUT, respectively.

Parallel chaining allows multiple DSPIs internal to a device and multiple SPI/DSI devices external to a device to share common SCK and PCS signals thereby saving pins. Two pins are saved per pair of DSPI/SPI. Figure 25-22 shows an example of how the blocks can be connected in a device.

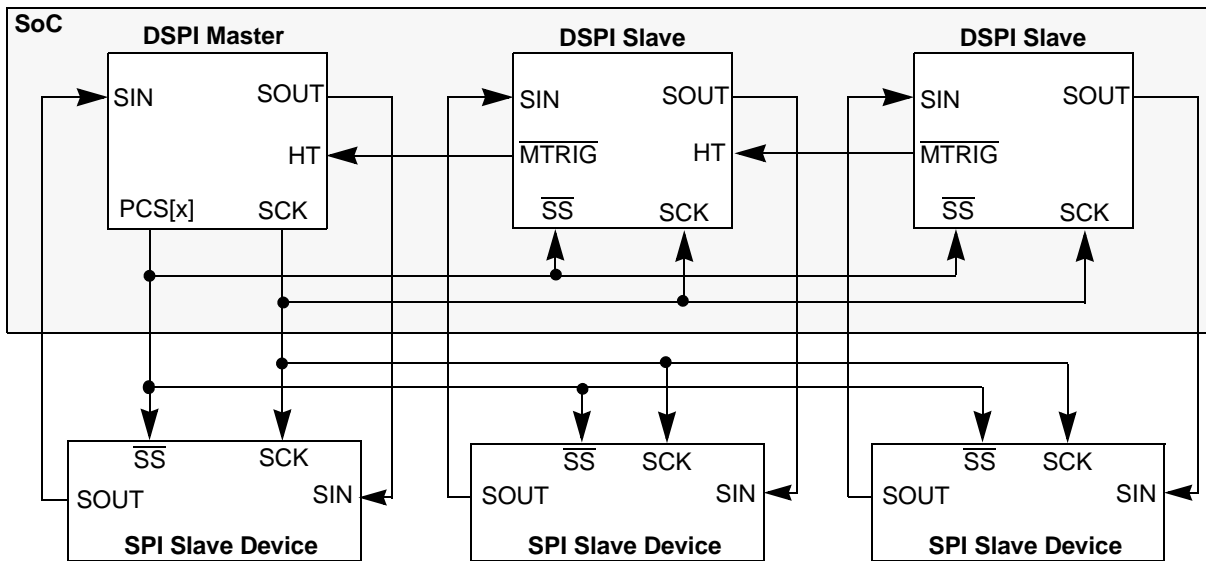

Figure 25-22. Example of Parallel Chaining of DSPIs

The DSPI master controls and initiates all transfer, but the DSPI slaves have a trigger output signal $\overline{\text{MTRIG}}$ that indicates to the master DSPI to start a transfer. When the DSPI slave has a change in its data to be serialized, it generates a pulse on the $\overline{\text{MTRIG}}$ signal to the master DSPI which initiates the transfer. When a DSPI slave has its HT signal asserted it also generates a pulse on its $\overline{\text{MTRIG}}$ signal thereby propagating trigger signals from other DSPI slaves to the DSPI master.

The MTOCNT field in the DSPI_DSICR must be written with the number of bits to be transferred. In parallel chaining the number written to MTOCNT must match the FMSZ field in the selected DSPI_CTAR register.

25.4.4.6.2 Serial Chaining

The serial chaining allows transfers of DSI frames of up to a total of 64 bits, using transfers of smaller DSI frames concatenated together by multiple DSPIs. Figure 25-23 shows an example of how the blocks can be connected in a device.

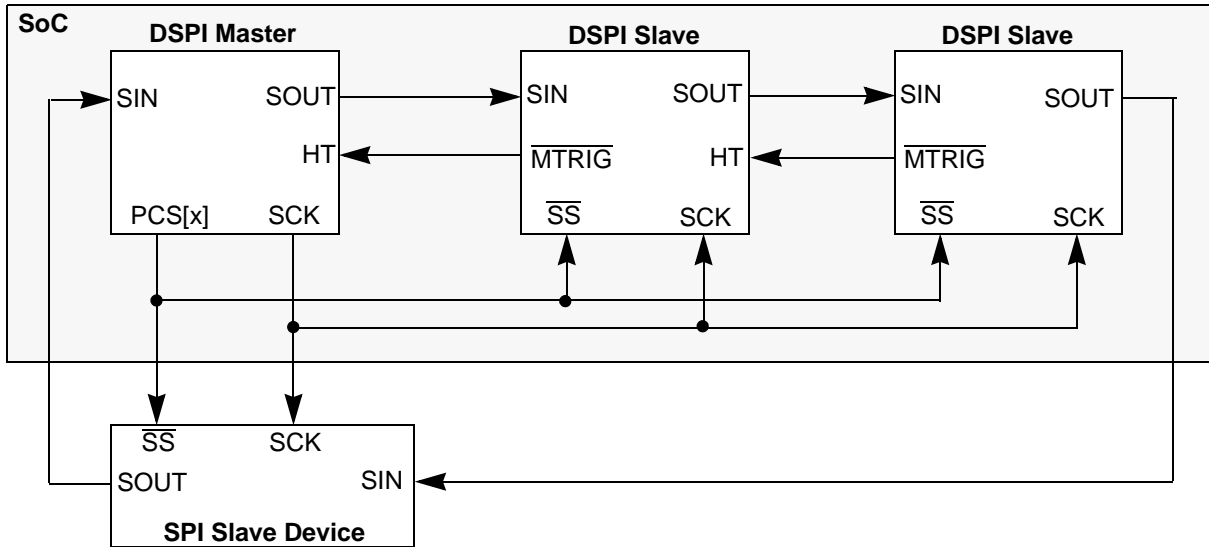

Figure 25-23. Example of Serial Chaining of DSPIs

The SOUT of the DSPI Master is connected to the SIN of the first DSPI slave. The SOUT of the first DSPI slave is connected to the SIN input of the second slave and so on. The SOUT of the last DSPI slave is connected to the SIN of the external SPI slave. The SOUT of the external SPI slave is connected to the SIN of the DSPI master.

The DSPI master controls and initiates all transfers, but the slave DSPIs use the trigger output signal $\overline{\text{MTRIG}}$ to indicate to the DSPI master that a trigger condition has occurred. When a DSPI slave has a change in data to be serialized it asserts the $\overline{\text{MTRIG}}$ signal to the DSPI master which initiates the transfer. When a DSPI slave has its HT signal asserted it will assert its $\overline{\text{MTRIG}}$ signal thereby propagating trigger signals from other DSPI slaves to the DSPI master.

The MTOCNT field in the DSPI_DSICR must be written with the total number of bits to be transferred. The MTOCNT field must equal the sum of all FMSZ fields in the selected DSPI_CTAR registers for the DSPI master and all DSPI slaves. For example if one 16-bit DSI frame is created by concatenating eight bits from the DSPI master, and four bits from each of the DSPI slaves in Figure 25-23, the DSPI master's frame size must be set to eight in the FMSZ field, and the DSPI slaves' frame size must be set to four. The largest DSI frame supported by the MTOCNT field is 64 bits. Any number of DSPIs can be connected together to concatenate DSI frames, as long as each DSPI transfers a minimum of 4 bits and a maximum of 16 bits and the total size of the concatenated frame is less than or equal to 64 bits long.

25.4.5 Combined Serial Interface (CSI) Configuration

The CSI Configuration of the DSPI is used to support SPI and DSI functions on a frame by frame basis. CSI Configuration allows interleaving of DSI data frames from the Parallel Input signals with SPI commands and data from the TX FIFO. The data returned from the bus slave is either used to drive the Parallel Output signals or it is stored in the RX FIFO. The CSI Configuration allows serialized data and configuration or diagnostic data to be transferred to a slave device using only one serial link. The DSPI is in CSI Configuration when the DCONF field in the DSPI_MCR is 0b10. Figure 25-24 shows an example

of how a DSPI can be used with a deserializing peripheral that supports SPI control for control and diagnostic frames.

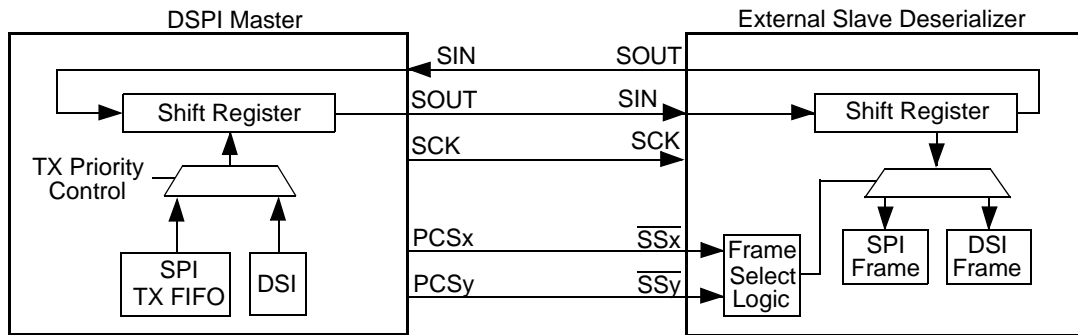

Figure 25-24. Example of System using DSPI in CSI Configuration

In CSI Configuration the DSPI transfers DSI data based on DSI Transfer Initiation Control. When there are SPI commands in the TX FIFO, the SPI data has priority over the DSI frames. When the TX FIFO is empty, DSI transfer resumes.

Two peripheral chip select signals indicate whether DSI data or SPI data is transmitted. The user must configure the DSPI so that the two CTAR registers associated with DSI data and SPI data assert different peripheral chip select signals denoted in the figure as PCSx and PCSy. The CSI Configuration is only supported in Master Mode.

Data returned from the external slave while a DSI frame is transferred is placed on the Parallel Output signals. Data returned from the external slave while a SPI frame is transferred is moved to the RX FIFO. The TX FIFO and RX FIFO are fully functional in CSI mode.

25.4.5.1 CSI Serialization

Serialization in the CSI configuration is similar to serialization in DSI Configuration. The transfer attributes for SPI frames are determined by the DSPI_CTAR register selected by the CTAS field in the SPI command halfword. The transfer attributes for the DSI frames are determined by the DSPI_CTAR register selected by the DSICTAS field in the DSPI_DSICR. [Figure 25-25](#) shows the CSI Serialization logic.

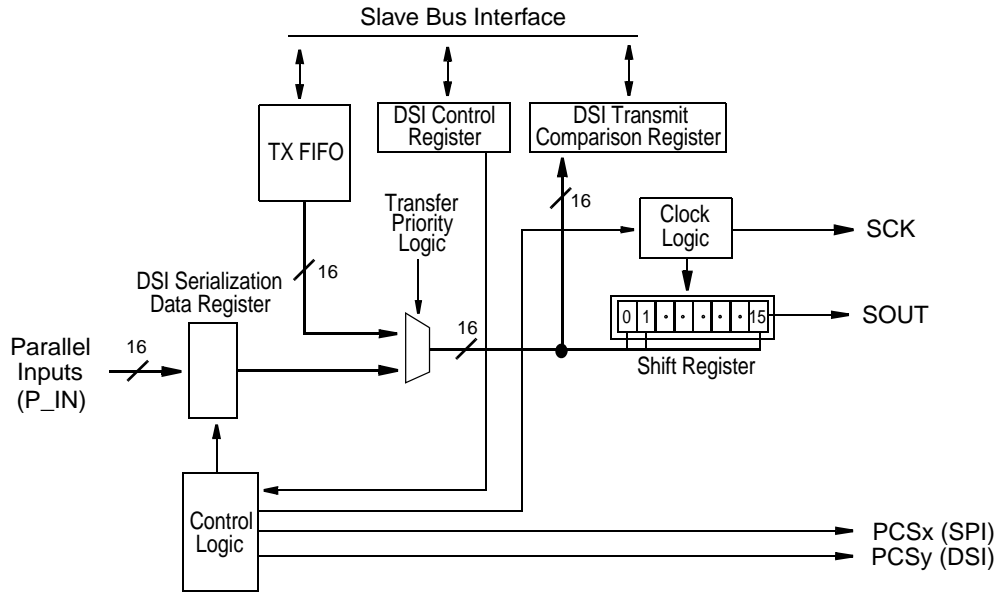

Figure 25-25. CSI Serialization Diagram

The Parallel Inputs signal states are latched into the DSPI DSI Serialization Data Register (DSPI_SDR) on the rising edge of every system clock and serialized based on the transfer initiation control settings in the DSPI_DSICR. When SPI frames are written to the TX FIFO they have priority over DSI data from the DSPI_SDR and are transferred at the next frame boundary. A copy of the most recently transferred DSI frame is stored in the DSPI_COMPR. The Transfer Priority Logic selects the source of the serialized data and asserts the appropriate CS signal.

25.4.5.2 CSI Deserialization

The deserialized frames in CSI Configuration goes into the DSPI_SDR or the RX FIFO based on the transfer priority logic. When DSI frames are transferred the returned frames are deserialized and latched into the DSPI_DDR. When SPI frames are transferred the returned frames are deserialized and written to the RX FIFO. [Figure 25-26](#) shows the CSI Deserialization logic.

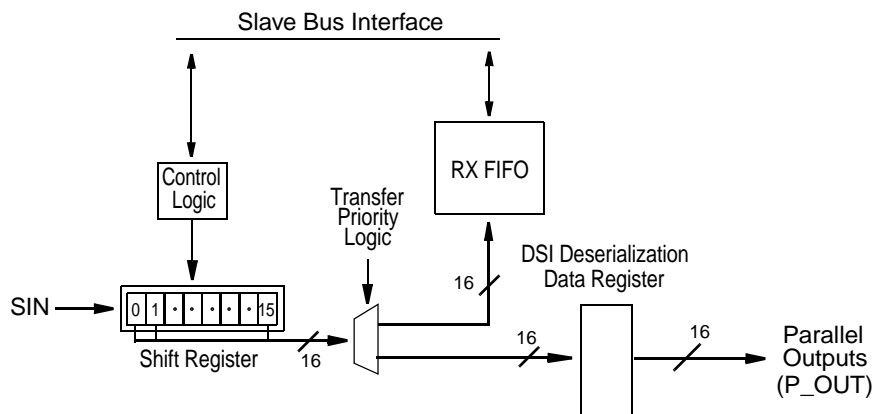

Figure 25-26. CSI Deserialization Diagram

25.4.6 DSPI Baud Rate and Clock Delay Generation

The SCK frequency and the delay values for serial transfer are generated by dividing the system clock frequency by a prescaler and a scaler with the option for doubling the baud rate. [Figure 25-27](#) shows conceptually how the SCK signal is generated.

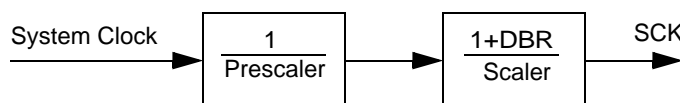

Figure 25-27. Communications Clock Prescalers and Scalers

25.4.6.1 Baud Rate Generator

The Baud Rate is the frequency of the Serial Communication Clock (SCK). The system clock is divided by a prescaler (PBR) and scaler (BR) to produce SCK with the possibility of halving the scaler division. The DBR, PBR and BR fields in the DSPI_CTAR registers select the frequency of SCK by the formula in the BR[0:3] field description. [Table 25-28](#) shows an example of how to compute the baud rate.

Table 25-28. Baud Rate Computation Example

| PBR | Prescaler | BR | Scaler | DBR | f _{periph} | Baud Rate |
|------|-----------|--------|--------|-----|---------------------|-----------|
| 0b00 | 2 | 0b0000 | 2 | 0 | 100 MHz | 25 Mb/s |
| 0b00 | 2 | 0b0000 | 2 | 1 | 20 MHz | 10 Mb/s |

25.4.6.2 PCS to SCK Delay (t_{CSC})

The PCS to SCK delay is the length of time from assertion of the PCS signal to the first SCK edge. See [Figure 25-29](#) for an illustration of the PCS to SCK delay. The PCSSCK and CSSCK fields in the DSPI_CTAR_x registers select the PCS to SCK delay by the formula in the CSSCK[0:3] bit description. [Table 25-29](#) shows an example of how to compute the PCS to SCK delay.

Table 25-29. PCS to SCK Delay Computation Example

| PCSSCK | Prescaler | CSSCK | Scaler | f _{periph} | PCS to SCK Delay |
|--------|-----------|--------|--------|---------------------|------------------|
| 0b01 | 3 | 0b0100 | 32 | 100 MHz | 0.96 μs |

25.4.6.3 After SCK Delay (t_{ASC})

The After SCK Delay is the length of time between the last edge of SCK and the negation of PCS. See [Figure 25-29](#) and [Figure 25-30](#) for illustrations of the After SCK delay. The PASC and ASC fields in the DSPI_CTAR_x registers select the After SCK Delay by the formula in the ASC[0:3] field description. [Table 25-30](#) shows an example of how to compute the After SCK delay.

Table 25-30. After SCK Delay Computation Example

| PASC | Prescaler | ASC | Scaler | f _{periph} | After SCK Delay |
|------|-----------|--------|--------|---------------------|-----------------|
| 0b01 | 3 | 0b0100 | 32 | 100 MHz | 0.96 μs |

25.4.6.4 Delay after Transfer (t_{DT})

The Delay after Transfer is the length of time between negation of the PCS signal for a frame and the assertion of the PCS signal for the next frame. See [Figure 25-29](#) for an illustration of the Delay after Transfer. The PDT and DT fields in the DSPI_CTARx registers select the Delay after Transfer by the formula in the DT[0:3] field description. [Table 25-31](#) shows an example of how to compute the Delay after Transfer.

Table 25-31. Delay after Transfer Computation Example

| PDT | Prescaler | DT | Scaler | f_{periph} | Delay after Transfer |
|------|-----------|--------|--------|---------------------|----------------------|
| 0b01 | 3 | 0b1110 | 32768 | 100 MHz | 0.98 ms |

When in non-continuous clock mode the t_{DT} delay is configurable as outlined in the DSPI_CTARx registers. When in continuous clock mode and TSB is not enabled the delay is fixed at 1 SCK period. When in TSB and continuous mode the delay is programmed as outlined in the DSPI_CTARx registers but in the event that the delay does not coincide with an SCK period in duration the delay is extended to the next SCK active edge. [Table 25-32](#) shows an example of how to compute the Delay after Transfer with the clock period of SCK defined as T_{SCK} . The values calculated assume 1 T_{SCK} period = 4 ipg_clk .

Table 25-32. Delay after Transfer Computation Example in TSB Configuration

| | | PDT field | | | |
|----------|-----------------------------|-----------|-------|--------|-------|
| | | 0 | 1 | 2 | 3 |
| DT field | t_{DT}^1 (T_{SCK}) | | | | |
| | 0 ² | 1 | 2 | 3 | 4 |
| | 1 | 1 | 3 | 5 | 7 |
| | 2 | 2 | 6 | 10 | 14 |
| | 3 | 4 | 12 | 20 | 28 |
| | 4 | 8 | 24 | 40 | 56 |
| | 5 | 16 | 48 | 80 | 112 |
| | 6 | 32 | 96 | 160 | 224 |
| | 7 | 64 | 192 | 320 | 448 |
| | 8 | 128 | 384 | 640 | 896 |
| | 9 | 256 | 768 | 1280 | 1792 |
| | 10 | 512 | 1536 | 2560 | 3584 |
| | 11 | 1024 | 3072 | 5120 | 7168 |
| | 12 | 2048 | 6144 | 10240 | 14336 |
| | 13 | 4096 | 12288 | 20480 | 28672 |
| | 14 | 8192 | 24576 | 40960 | 57344 |
| 15 | 16384 | 49152 | 81920 | 114688 | |

NOTES:

- ¹ Some values are not reachable (i. e. 9, 11, 13, 15, 17, 18, 19...), to calculate these values, please see the [Equation 25-3](#)
- ² The values in this row were rounded to the next integer value

25.4.6.5 Peripheral Chip Select Strobe Enable (\overline{PCSS})

The \overline{PCSS} signal provides a delay to allow the PCS signals to settle after a transition occurs thereby avoiding glitches. When the DSPI is in Master Mode and PCSSE bit is set in the DSPI_MCR, \overline{PCSS} provides a signal for an external demultiplexer to decode the PCS[0] -PCS[4] and PCS[6] -PCS[7] signals into as many as 128 glitch-free PCS signals. [Figure 25-28](#) shows the timing of the \overline{PCSS} signal relative to PCS signals.

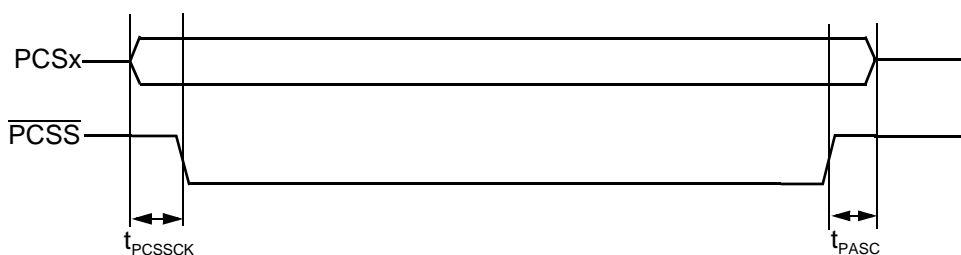

Figure 25-28. Peripheral Chip Select Strobe Timing

The delay between the assertion of the PCS signals and the assertion of \overline{PCSS} is selected by the PCSSCK field in the DSPI_CTAR based on the following formula:

$$t_{PCSSCK} = \frac{1}{f_{periph}} \times PCSSCK \tag{Eqn. 25-5}$$

At the end of the transfer the delay between \overline{PCSS} negation and PCS negation is selected by the PASC field in the DSPI_CTAR based on the following formula:

$$t_{PASC} = \frac{1}{f_{periph}} \times PASC \tag{Eqn. 25-6}$$

[Table 25-33](#) shows an example of how to compute the t_{pcssck} delay.

Table 25-33. Peripheral Chip Select Strobe Assert Computation Example

| PCSSCK | Prescaler | f_{periph} | Delay before Transfer |
|--------|-----------|--------------|-----------------------|
| 0b11 | 7 | 100 MHz | 70.0 ns |

[Table 25-34](#) shows an example of how to compute the t_{pasc} delay.

Table 25-34. Peripheral Chip Select Strobe Negate Computation Example

| PASC | Prescaler | f_{periph} | Delay after Transfer |
|------|-----------|--------------|----------------------|
| 0b11 | 7 | 100 MHz | 70.0 ns |

The \overline{PCSS} signal is not supported when Continuous Serial Communication SCK is enabled (CONT_SCKE=1).

25.4.7 Transfer Formats

The SPI serial communication is controlled by the Serial Communications Clock (SCK) signal and the PCS signals. The SCK signal provided by the Master device synchronizes shifting and sampling of the data on the SIN and SOUT pins. The PCS signals serve as enable signals for the slave devices.

When the DSPI is the bus master, the CPOL and CPHA bits in the DSPI Clock and Transfer Attributes Registers (DSPI_CTARx) select the polarity and phase of the serial clock, SCK. The polarity bit selects the idle state of the SCK. The clock phase bit selects if the data on SOUT is valid before or on the first SCK edge.

When the DSPI is the bus Slave, CPOL and CPHA bits in the DSPI_CTAR0 (SPI) or DSPI_CTAR1 (DSI) select the polarity and phase of the serial clock. For SPI Slaves the DSPI_CTAR0 is used, and for DSI Slaves the DSPI_CTAR1 is used. Even though the bus Slave does not control the SCK signal, clock polarity, clock phase and number of bits to transfer must be identical for the master device and the slave device to ensure proper transmission.

The DSPI supports four different transfer formats:

- Classic SPI with CPHA=0
- Classic SPI with CPHA=1
- Modified Transfer format with CPHA = 0
- Modified Transfer format with CPHA = 1

A modified transfer format is supported to allow for high-speed communication with peripherals that require longer setup times. The DSPI can sample the incoming data later than halfway through the cycle to give the peripheral more setup time. The MTFE bit in the DSPI_MCR selects between Classic SPI Format and Modified Transfer Format. The Classic SPI Formats are described in [Section 25.4.7.1, Classic SPI Transfer Format \(CPHA = 0\)](#), and [Section 25.4.7.2, Classic SPI Transfer Format \(CPHA = 1\)](#). The Modified Transfer Formats are described in [Section 25.4.7.3, Modified SPI/DSI Transfer Format \(MTFE = 1, CPHA = 0\)](#), and [Section 25.4.7.4, Modified SPI/DSI Transfer Format \(MTFE = 1, CPHA = 1\)](#).

In the SPI and DSI Configurations, the DSPI provides the option of keeping the PCS signals asserted between frames. See [Section 25.4.7.5, Continuous Selection Format](#), for details.

25.4.7.1 Classic SPI Transfer Format (CPHA = 0)

The transfer format shown in [Figure 25-29](#) is used to communicate with peripheral SPI slave devices where the first data bit is available on the first clock edge. In this format, the master and slave sample their SIN pins on the odd-numbered SCK edges and change the data on their SOUT pins on the even-numbered SCK edges.

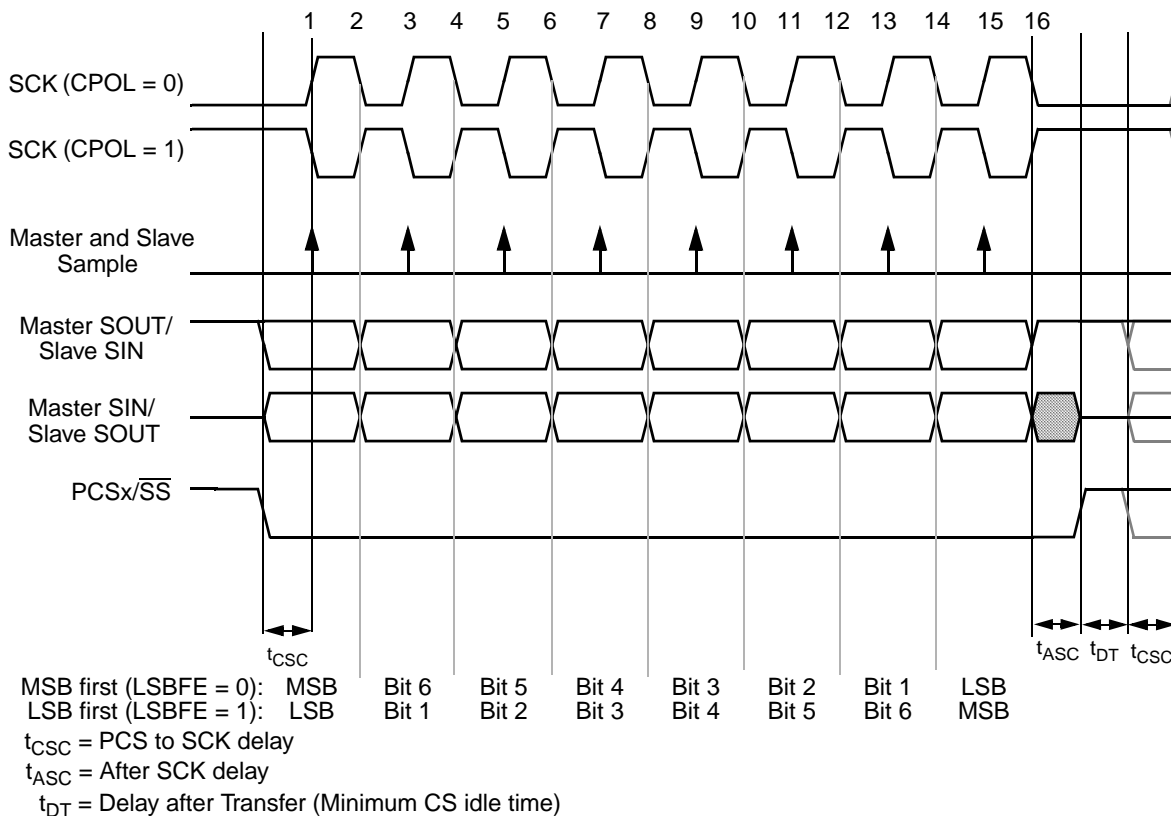

Figure 25-29. DSPI Transfer Timing Diagram (MTFE=0, CPHA=0, FMSZ=8)

The master initiates the transfer by placing its first data bit on the SOUT pin and asserting the appropriate peripheral chip select signals to the slave device. The slave responds by placing its first data bit on its SOUT pin. After the t_{CSC} delay has elapsed, the master outputs the first edge of SCK. This is the edge used by the master and slave devices to sample the first input data bit on their serial data input signals. At the second edge of the SCK the master and slave devices place their second data bit on their serial data output signals. For the rest of the frame the master and the slave sample their SIN pins on the odd-numbered clock edges and changes the data on their SOUT pins on the even-numbered clock edges. After the last clock edge occurs a delay of t_{ASC} is inserted before the master negates the PCS signals. A delay of t_{DT} is inserted before a new frame transfer can be initiated by the master.

25.4.7.2 Classic SPI Transfer Format (CPHA = 1)

This transfer format shown in [Figure 25-30](#) is used to communicate with peripheral SPI slave devices that require the first SCK edge before the first data bit becomes available on the slave SOUT pin. In this format the master and slave devices change the data on their SOUT pins on the odd-numbered SCK edges and sample the data on their SIN pins on the even-numbered SCK edges

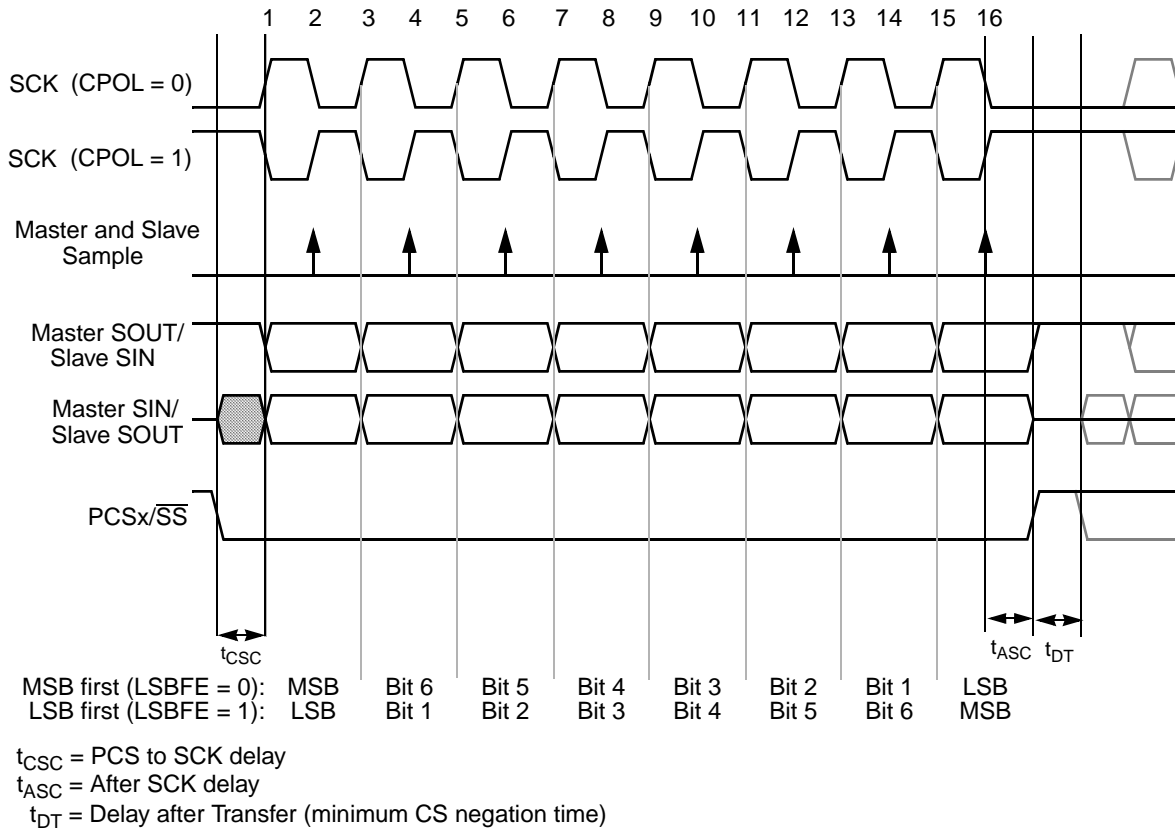

Figure 25-30. DSPI Transfer Timing Diagram (MTFE=0, CPHA=1, FMSZ=8)

The master initiates the transfer by asserting the PCS signal to the slave. After the t_{CSC} delay has elapsed, the master generates the first SCK edge and at the same time places valid data on the master SOUT pin. The slave responds to the first SCK edge by placing its first data bit on its slave SOUT pin.

At the second edge of the SCK the master and slave sample their SIN pins. For the rest of the frame the master and the slave change the data on their SOUT pins on the odd-numbered clock edges and sample their SIN pins on the even-numbered clock edges. After the last clock edge occurs a delay of t_{ASC} is inserted before the master negates the PCS signal. A delay of t_{DT} is inserted before a new frame transfer can be initiated by the master.

25.4.7.3 Modified SPI/DSI Transfer Format (MTFE = 1, CPHA = 0)

In this Modified Transfer Format both the Master and the Slave sample later in the SCK period than in Classic SPI mode to allow for delays in device pads and board traces. These delays become a more significant fraction of the SCK period as the SCK period decreases with increasing baud rates.

The Master and the Slave places data on the SOUT pins at the assertion of the PCS signal. After the PCS to SCK delay has elapsed the first SCK edge is generated. The Slave samples the Master SOUT signal on every odd numbered SCK edge. The Slave also places new data on the Slave SOUT on every odd numbered clock edge.

The Master places its second data bit on the SOUT line one system clock after odd numbered SCK edge. The point where the Master samples the Slave SOUT is selected by writing to the SMPL_PT field in the DSPI_MCR. The SMPL_PT field description in Table 25-5 lists the number of system clock cycles between the active edge of SCK and the Master Sample point. The Master sample point can be delayed by one or two system clock cycles.

Figure 25-31 shows the modified transfer format for CPHA = 0. Only the condition where CPOL = 0 is illustrated. The delayed Master sample points are indicated with a lighter shaded arrow.

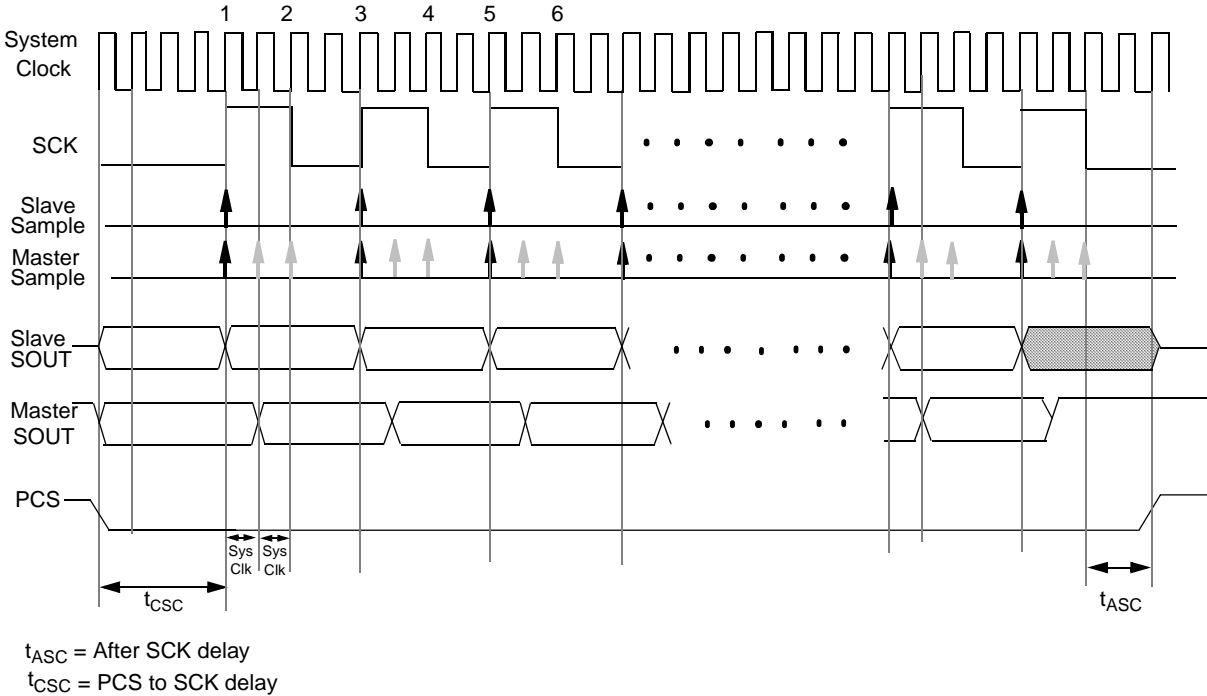

Figure 25-31. DSPI Modified Transfer Format (MTFE=1, CPHA=0, $f_{sck} = f_{periph}/4$)

25.4.7.4 Modified SPI/DSI Transfer Format (MTFE = 1, CPHA = 1)

Figure 25-32 shows the Modified Transfer Format for CPHA = 1. Only the condition where CPOL = 0 is described. At the start of a transfer the DSPI asserts the PCS signal to the slave device. After the PCS to SCK delay has elapsed the master and the slave put data on their SOUT pins at the first edge of SCK. The Slave samples the Master SOUT signal on the even numbered edges of SCK. The Master samples the Slave SOUT signal on the odd numbered SCK edges starting with the third SCK edge. The Slave samples the last bit on the last edge of the SCK. The Master samples the last Slave SOUT bit one half SCK cycle after the last edge of SCK. No clock edge will be visible on the Master SCK pin during the sampling of the last bit. The SCK to PCS delay must be greater or equal to half of the SCK period.

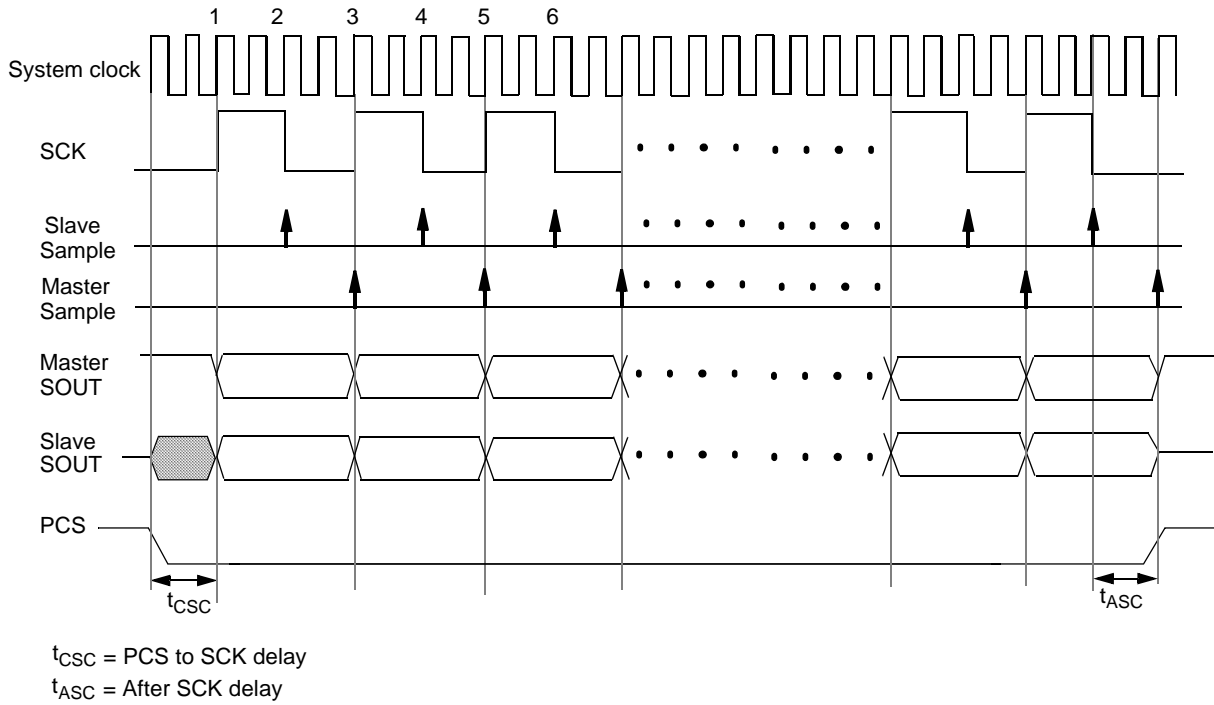

Figure 25-32. DSPI Modified Transfer Format (MTFE=1, CPHA=1, $f_{sck} = f_{periph}/4$)

25.4.7.5 Continuous Selection Format

Some peripherals must be deselected between every transfer. Other peripherals must remain selected between several sequential serial transfers. The Continuous Selection Format provides the flexibility to handle both cases. The Continuous Selection Format is enabled for the SPI Configuration by setting the CONT bit in the SPI command. Continuous Selection is enabled for the DSI Configuration by setting the DCONT bit in the DSPI_DSICR. The behavior of the PCS signals in the two configurations is identical so only SPI Configuration will be described.

When the CONT bit = 0, the DSPI drives the asserted Chip Select signals to their idle states in between frames. The idle states of the Chip Select signals are selected by the PCSIS field in the DSPI_MCR. [Figure 25-33](#) shows the timing diagram for two four-bit transfers with CPHA = 1 and CONT = 0.

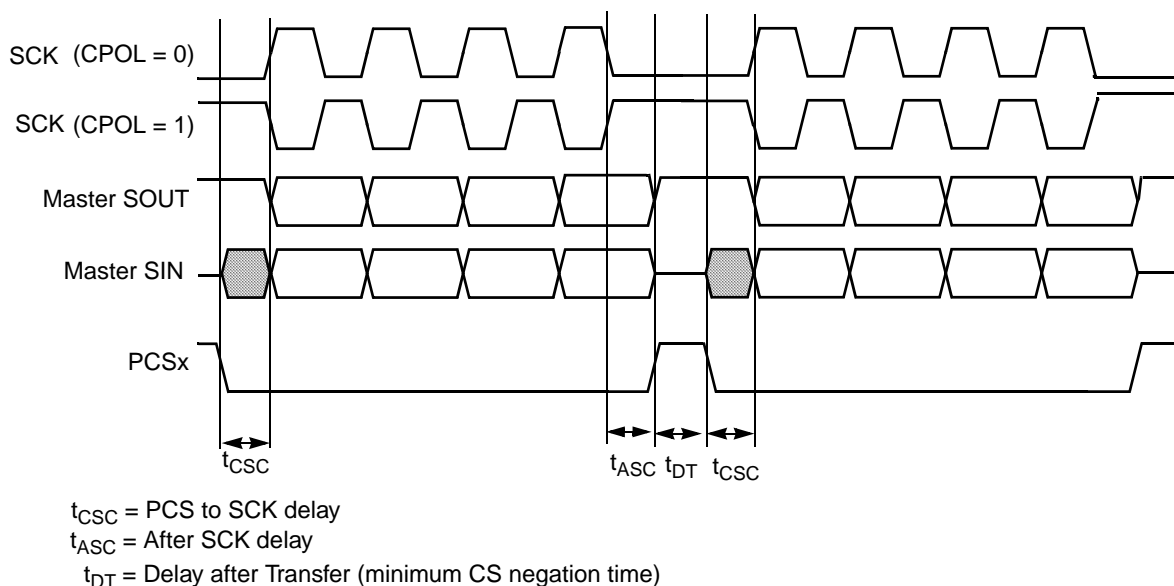

Figure 25-33. Example of Non-Continuous Format (CPHA=1, CONT=0)

When the CONT bit = 1, the PCS signal remains asserted for the duration of the two transfers. The Delay between Transfers (t_{DT}) is not inserted between the transfers. Figure 25-34 shows the timing diagram for two four-bit transfers with CPHA = 1 and CONT = 1.

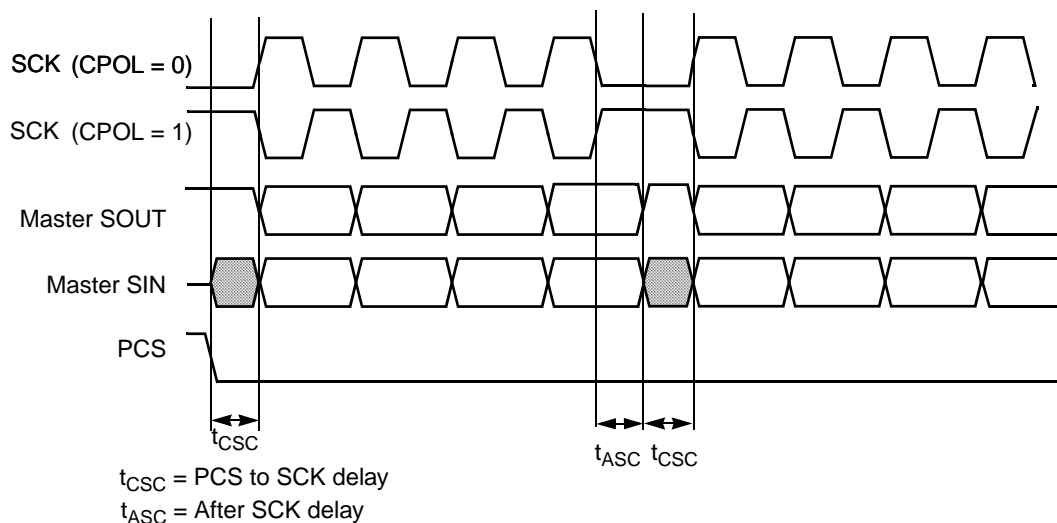

Figure 25-34. Example of Continuous Transfer (CPHA=1, CONT=1)

Switching CTAR registers or changing which PCS signals are asserted between frames while using Continuous Selection can cause errors in the transfer. The PCS signal should be negated before CTAR is switched or different PCS signals are selected.

WARNING

During continuous selection mode, to avoid generation of erroneous data, do not change the DSPIx_CTAR values between frames in the following conditions:

- If DSPIx_CTARn[CPHA=1] AND DSPIx_MCR[CONT_SCKE]=0, do not change DSPIx_CTARn[CPOL, CPHA, PCSSCK or PBR] between frames.
- If DSPIx_CTARn[CPHA]=0 OR DSPIx_MCR[CONT_SCKE]=1, do not change any bit field of DSPIx_CTARn, except [PBR], between frames.

25.4.8 Continuous Serial Communications Clock

The DSPI provides the option of generating a continuous SCK signal for slave peripherals that require a continuous clock.

Continuous SCK is enabled by setting the CONT_SCKE bit in the DSPI_MCR. Continuous SCK is valid in all configurations.

Continuous SCK is only supported for CPHA=1. Setting CPHA=0 will be ignored if the CONT_SCKE bit is set. Continuous SCK is supported for Modified Transfer Format.

Clock and transfer attributes for the Continuous SCK mode are set according to the following rules:

- When the DSPI is in SPI configuration, CTAR0 shall be used initially. At the start of each SPI frame transfer, the CTAR specified by the CTAS for the frame shall be used.
- When the DSPI is in DSI configuration, the CTAR specified by the DSICTAS field shall be used at all times.
- When the DSPI is in CSI configuration, the CTAR selected by the DSICTAS field shall be used initially. At the start of a SPI frame transfer, the CTAR specified by the CTAS value for the frame shall be used. At the start of a DSI frame transfer, the CTAR specified by the DSICTAS field shall be used.
- In all configurations, the currently selected CTAR shall remain in use until the start of a frame with a different CTAR specified, or the Continuous SCK mode is terminated.

It is recommended that the baud rate is the same for all transfers made while using the Continuous SCK. Switching clock polarity between frames while using Continuous SCK can cause errors in the transfer. Continuous SCK operation is not guaranteed if the DSPI is put into the External Stop Mode or Module Disable Mode.

Enabling Continuous SCK disables the PCS to SCK delay and the Delay after Transfer (t_{DT}) is fixed at one T_{SCK} cycle. When TSB configuration is enabled the t_{DT} is programmable to a minimum of $1 \times T_{SCK}$ cycles by configuring PDT and DT values in the respective CTAR register. [Figure 25-35](#) shows timing diagram for Continuous SCK format with Continuous Selection disabled.

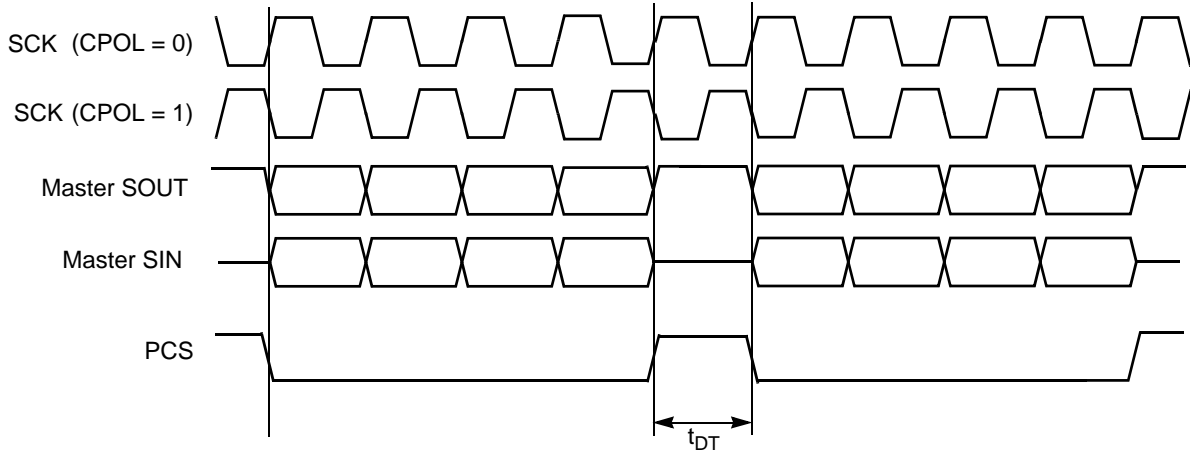

Figure 25-35. Continuous SCK Timing Diagram (CONT=0)

If the CONT bit in the TX FIFO entry is set or the DCONT in the DSPI_DSICR is set, PCS remains asserted between the transfers. Under certain conditions, SCK can continue with PCS asserted, but with no data being shifted out of SOUT (SOUT pulled high). This can cause the slave to receive incorrect data. Those conditions include:

- Continuous SCK with CONT bit set, but no data in the transmit FIFO.
- Continuous SCK with CONT bit set and entering STOPPED state (refer to [Section 25.4.2, Start and Stop of DSPI Transfers](#)).
- Continuous SCK with CONT bit set and entering Stop mode or Module Disable mode.

Figure 25-36 shows timing diagram for Continuous SCK format with Continuous Selection enabled.

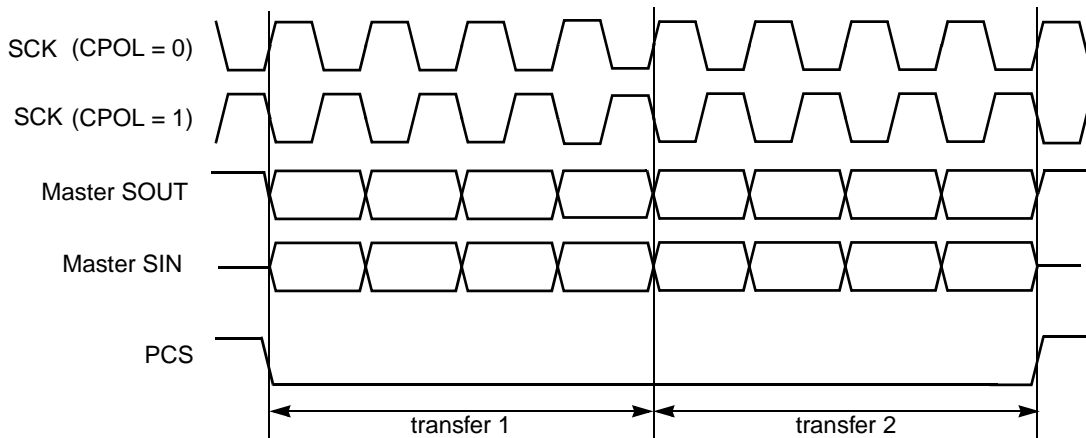

Figure 25-36. Continuous SCK Timing Diagram (CONT=1)

25.4.9 Timed Serial Bus (TSB)

The DSPI can be programmed in Timed Serial Bus configuration by asserting the TSBC bit in the DSPI_DSICR register, see [Section 25.3.2.10, DSPI DSI Configuration Register \(DSPI_DSICR\)](#), for

details. To work in TSB configuration the DSPI must be in master mode and configured as DSI (DCONF = 0b01). The TSB allows operating in Continuous and Non Continuous Serial Communication Clock (controlled by bit CONT_SCKE).

Figure 25-37 shows the signals used in the TSB interface. The SDR and ASDR registers are set to 32 bits in this configuration, to allow the Micro Second Channel (MSC) feature to be performed.

In the TSB configuration the DSPI manage to send from 4 up to 32 bits data. These bits source data can be either from the DSPI DSI Alternate Serialization Data Register (DSPI_ASDR), written by the host software, or from Parallel Input pin states latched into the DSPI DSI Serialization Data Register (DSPI_SDR).

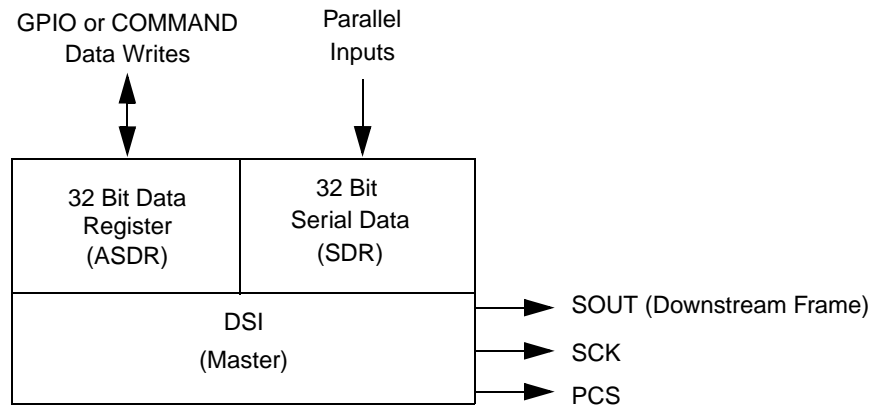
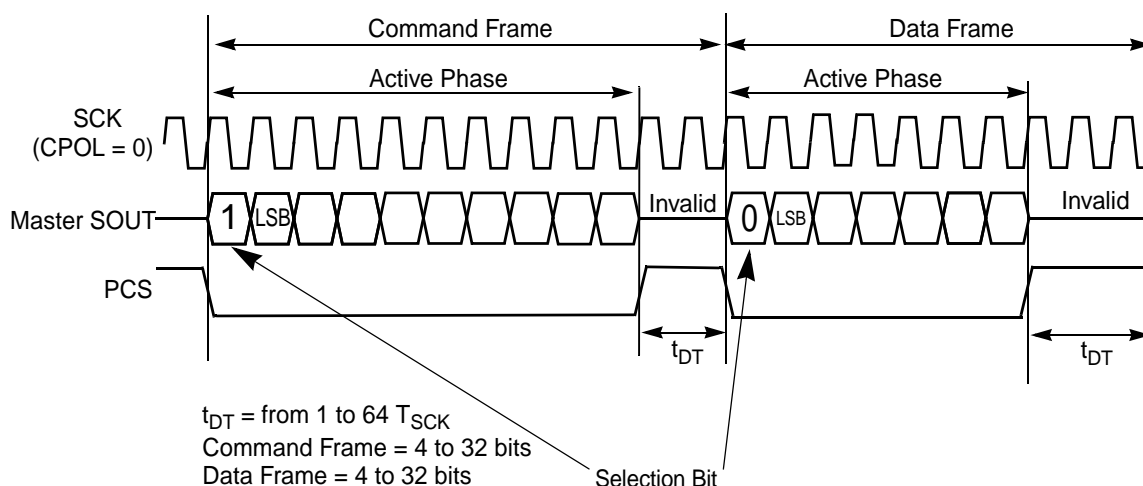

Figure 25-37. DSPI usage in the TSB Configuration

The same constraints applied to DSI are valid to TSB, but the frame size and the Delay After Transfer value (t_{DT}). The TSB configuration allows from 4 to 32 bits frame size to be used, and t_{DT} can be programmable to a minimum of $1 \times T_{SCK}$, allowing a programmable inter-message gap. See Table 25-12 and Table 25-32 for details on programming the t_{DT} values.

The time between the negation of the CS at the end of one frame to the assertion of CS at the next frame is defined by: $T_{DT} = P_{DT} * DT / f_{periph}$, but delayed until the next active edge of T_{SCK} . The gap is only be whole period of T_{SCK} and the PDT and DT fields of the specific DSPI_CTAR0-7 register select the delay after transfer. Some values will not be possible, see the reference manual for details.

Figure 25-38. TSB Downstream Frame

The Figure 25-38 shows the two types of downstream frames, command frame, and data frame, used in the TSB configuration, refer to [Section 25.4.9.1, PCS Switch Over Timing](#), and [Section 25.4.9.3, TSB Data Frame Format](#), for detailed information. The Command Word can be written by software, and the Data Word consisting of 32 bits words, from the SDR or ASDR registers. Only the downstream frame is supported in the TSB configuration, the upstream frame can be handled by software using any available serial input.

The selection bit, the start bit for a frame, is not a requirement but could be implemented by software. The number of the frame bits can be in the range of 4 to 32 bits. In this configuration the least significant bit of a frame should be transmitted first (LSBFE = 1).

25.4.9.1 PCS Switch Over Timing

When in TSB mode it is possible to switch the set of PCS signals that are driven during the first part of the frame to a different set of PCS signals during the second part of the frame. The bit at which this switch over occurs is contained in the DSICR register.

In order to maximize both the setup and hold time margins on the old and new PCS signals the timing of the switch over occurs on the active edge of the master SCK data capture between the last bit of the first part of the frame and the first bit of the second part of the frame. For example, if the first part of the frame is 5 bits and the second part of the frame is 10 bits the PCS signals will switch at the active edge of the master SCK in between bits 5 and 6 of the frame as seen by the slave. The exact timing between the external signals SCK and PCS signals will not be exactly aligned due to routing and pad differences. This approach ensures that larger/shorter SCK periods will result in approximately symmetric increases/decreases of setup and hold margins on the PCS signals. The setup time for the PCS signals before the first bit of the first part of the frame and the hold time for the PCS signals after the last bit of the second part of the frame are unchanged in this mode with respect to the other modes and remain controlled by the CSC and ASC delay fields respectively when not in Continuous SCK mode.

25.4.9.2 TSB Command Frame Format

In the TSB configuration a command frame is shown in [Figure 25-39](#).

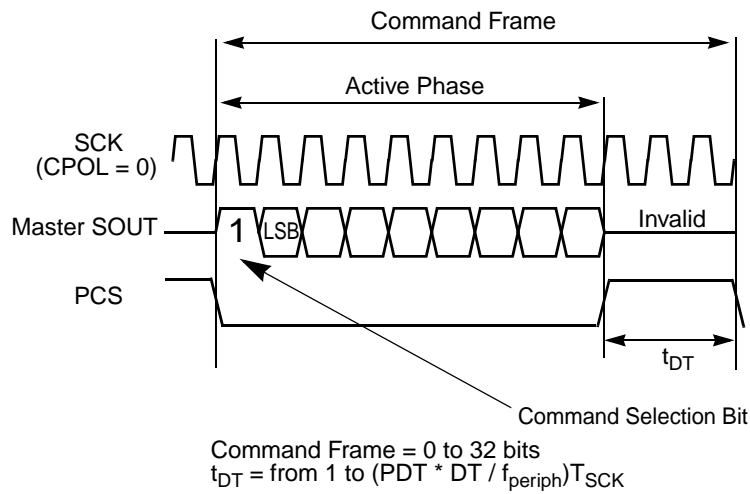

Figure 25-39. Command Frame Format

In the active phase of the command frame, the chip select becomes active validating the SOUT and SCK output signals. Outside the active phase, chip select is at passive level and invalid data may occur at SOUT.

For TSB configuration, assuming $CPOL = 0$, the SOUT output and the chip select changes its state always with the SCK rising edge. The SOUT signal must be sampled in the slave device with the falling edge of SCK. The clock period of SCK is defined as T_{SCK} . The length of the command frame passive phase t_{DT} should always be fixed to a minimum of $1 \times T_{SCK}$.

25.4.9.3 TSB Data Frame Format

A data frame is transmitted from the TSB controller to the receiving devices, [Figure 25-40](#) details the frame active and passive phase,

For TSB configuration assuming $CPOL = 0$, the SOUT output and the chip select change their states always with the SCK rising edge. The SOUT signal must be sampled in the receiving device with the falling edge of SCK. The length of the data frame passive phase t_{DT} can be a minimum of $1 \times T_{SCK}$.

A data frame can be composed by data bits only or by data bits preceded by a selection bit, see [Figure 25-40](#). A data frame with a selection bit always starts with a low level bit at SOUT.

The number of data bits in the active phase is from 4 to 32 bits, and the least significant bit of a data portion is transmitted first ($LSBFE = 1$).

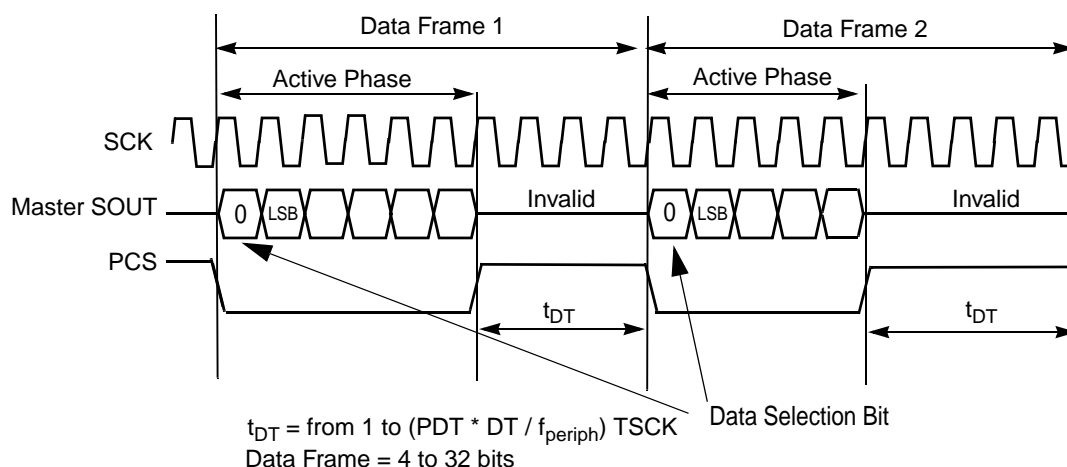

Figure 25-40. TSB Data Frame Format

25.4.10 Interrupts/DMA Requests

The DSPI has four conditions that can only generate interrupt requests and two conditions that can generate interrupt or DMA request. Table 25-35 lists the six conditions.

Table 25-35. Interrupt and DMA Request Conditions

| Condition | Flag | Interrupt | DMA |
|--------------------|------|-----------|-----|
| End of Queue (EOQ) | EOQF | X | |
| TX FIFO Fill | TFFF | X | X |
| Transfer Complete | TCF | X | |
| TX FIFO Underflow | TFUF | X | |
| RX FIFO Drain | RFDF | X | X |
| RX FIFO Overflow | RFOF | X | |

Each condition has a flag bit in the DSPI Status Register (DSPI_SR) and an Request Enable bit in the DSPI DMA/Interrupt Request Select and Enable Register (DSPI_RSER). The TX FIFO Fill Flag (TFFF) and RX FIFO Drain Flag (RFDF) generate interrupt requests or DMA requests depending on the TFFF_DIRS and RFDF_DIRS bits in the DSPI_RSER.

25.4.10.1 End of Queue Interrupt Request

The End of Queue Request indicates that the end of a transmit queue is reached. The End of Queue Request is generated when the EOQ bit in the executing SPI command is asserted and the EOQF_RE bit in the DSPI_RSER is asserted.

25.4.10.2 Transmit FIFO Fill Interrupt or DMA Request

The Transmit FIFO Fill Request indicates that the TX FIFO is not full. The Transmit FIFO Fill Request is generated when the number of entries in the TX FIFO is less than the maximum number of possible entries,

and the TFFF_RE bit in the DSPI_RSER is asserted. The TFFF_DIRS bit in the DSPI_RSER selects whether a DMA request or an interrupt request is generated.

25.4.10.3 Transfer Complete Interrupt Request

The Transfer Complete Request indicates the end of the transfer of a serial frame. The Transfer Complete Request is generated at the end of each frame transfer when the TCF_RE bit is set in the DSPI_RSER.

25.4.10.4 Transmit FIFO Underflow Interrupt Request

The Transmit FIFO Underflow Request indicates that an underflow condition in the TX FIFO has occurred. The transmit underflow condition is detected only for DSPI blocks operating in slave mode and SPI configuration. The TFUF bit is set when the TX FIFO of a DSPI operating in slave mode and SPI configuration is empty, and a transfer is initiated from an external SPI master. If the TFUF bit is set while the TFUF_RE bit in the DSPI_RSER is asserted, an interrupt request is generated.

25.4.10.5 Receive FIFO Drain Interrupt or DMA Request

The Receive FIFO Drain Request indicates that the RX FIFO is not empty. The Receive FIFO Drain Request is generated when the number of entries in the RX FIFO is not zero, and the RFDF_RE bit in the DSPI_RSER is asserted. The RFDF_DIRS bit in the DSPI_RSER selects whether a DMA request or an interrupt request is generated.

25.4.10.6 Receive FIFO Overflow Interrupt Request

The Receive FIFO Overflow Request indicates that an overflow condition in the RX FIFO has occurred. A Receive FIFO Overflow request is generated when RX FIFO and shift register are full and a transfer is initiated. The RFOF_RE bit in the DSPI_RSER must be set for the interrupt request to be generated.

Depending on the state of the ROOE bit in the DSPI_MCR, the data from the transfer that generated the overflow is either ignored or shifted in to the shift register. If the ROOE bit is set, the incoming data is shifted in to the shift register. If the ROOE bit is negated, the incoming data is ignored.

25.4.11 Power Saving Features

The DSPI supports three power-saving strategies:

- External Stop Mode
- Module Disable Mode - Clock gating of non-memory mapped logic
- Clock gating of slave bus signals and clock to memory-mapped logic

The External Stop Mode requires a block external to the DSPI to implement the SoC power management and clock gating control. All power saving features require logic external to the DSPI. [Figure 25-41](#) shows an example on how the DSPI power saving features can be used in a device.

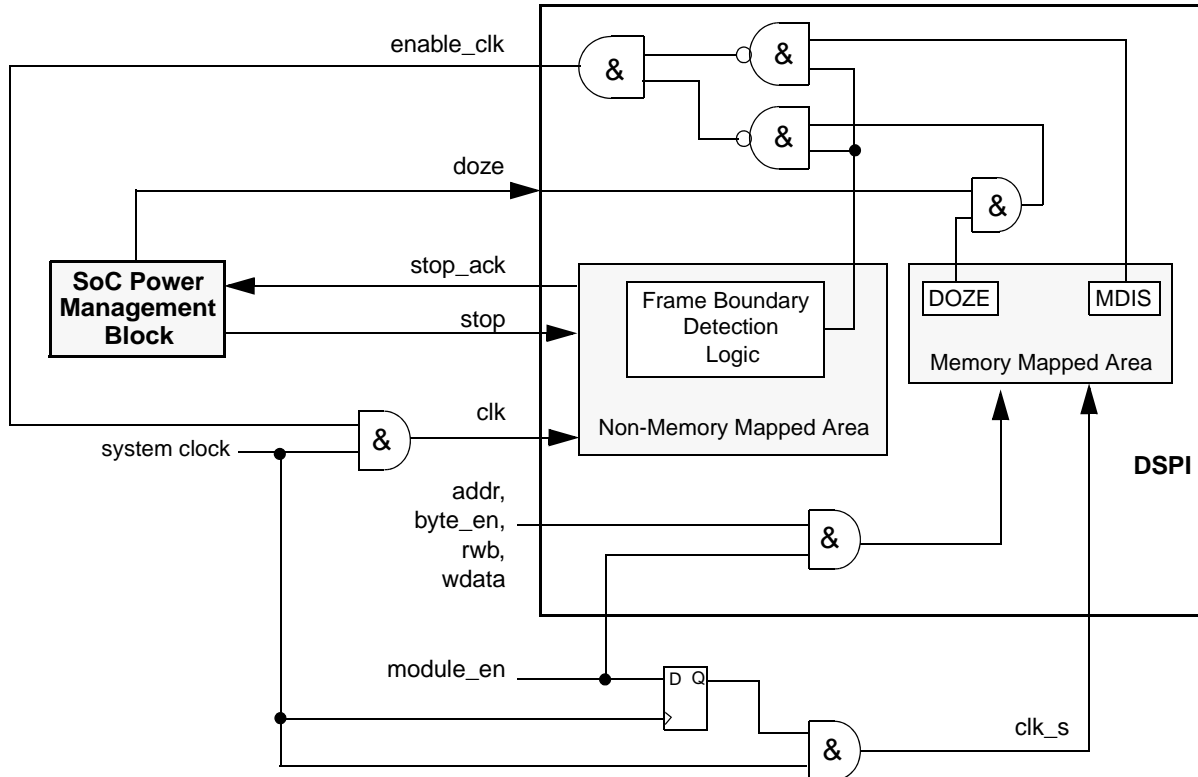

Figure 25-41. Example of a DSPI in a device with a Power Management Block

25.4.11.1 Stop Mode (External Stop Mode)

The DSPI supports the Stop Mode protocol. When a request is made to enter External Stop Mode, the DSPI block acknowledges the request by negating `ipg_stop_ack`. When the DSPI is ready to have its clocks shut off the `ipg_stop_ack` signal is asserted. If a serial transfer is in progress, the DSPI waits until it reaches the frame boundary before it asserts `ipg_stop_ack`. While the clocks are shut off, the DSPI memory-mapped logic is not accessible. The states of the interrupt and DMA request signals cannot be changed while in External Stop Mode.

25.4.11.2 Module Disable Mode

Module Disable Mode is a block-specific mode that the DSPI can enter to save power. Host software can initiate the Module Disable Mode by writing a '1' to the MDIS bit in the DSPI_MCR. The Module Disable Mode can also be initiated by hardware. A power management block can initiate Module Disable Mode by asserting the `ipg_doze` signal while the DOZE bit in the DSPI_MCR is asserted.

When the MDIS bit is asserted or the `ipg_doze` signal is asserted while the DOZE bit is asserted, the DSPI negates `ipg_enable_clk` at the next frame boundary. If implemented, the `ipg_enable_clk` signal can stop the clock to the non-memory mapped logic. When `ipg_enable_clk` is negated, the DSPI is in a dormant state, but the memory mapped registers are still accessible. Certain read or write operations have a different affect when the DSPI is in the Module Disable Mode. Reading the RX FIFO Pop Register will not change the state of the RX FIFO. Likewise, writing to the TX FIFO Push Register will not change the state of the

TX FIFO. Clearing either of the FIFOs will not have any affect in the Module Disable Mode. Changes to the DIS_TXF and DIS_RXF fields of the DSPI_MCR will not have any affect in the Module Disable Mode. In the Module Disable Mode, all status bits and register flags in the DSPI will return the correct values when read, but writing to them will have no affect. Writing to the DSPI_TCR during Module Disable Mode will not have any affect. Interrupt and DMA request signals cannot be cleared while in the Module Disable Mode.

25.4.11.3 Slave Bus Signal Gating

The DSPI's module enable signal is used to gate slave bus signals such as address, byte enable, read/write and data. This prevents toggling slave bus signals from propagating through parts of the DSPI's combinational logic and consuming power unless it is a DSPI access. The module enable signal can also be used to gate the clock to the memory-mapped logic.

25.5 Initialization/Application Information

25.5.1 How to Change Queues

This section presents an example of how to change queues for the DSPI. The queues are not part of the DSPI, but the DSPI includes features in support of queue management. Queues are primarily supported in SPI Configuration.

1. The last command word from a queue is executed. The EOQ bit in the command word is set to indicate to the DSPI that this is the last entry in the queue.
2. At the end of the transfer, corresponding to the command word with EOQ set is sampled, the EOQ flag (EOQF) in the DSPI_SR is set.
3. The setting of the EOQF flag will disable both serial transmission, and serial reception of data, putting the DSPI in the STOPPED state. The TXRXS bit is negated to indicate the STOPPED state.
4. The DMA will continue to fill TX FIFO until it is full or step 5 occurs.
5. Disable DSPI DMA transfers by disabling the DMA enable request for the DMA channel assigned to TX FIFO and RX FIFO. This is done by clearing the corresponding DMA enable request bits in the DMA Controller.
6. Ensure all received data in RX FIFO has been transferred to memory receive queue by reading the RXCNT in DSPI_SR or by checking RFDF in the DSPI_SR after each read operation of the DSPI_POPR.
7. Modify DMA descriptor of TX and RX channels for "new" queues
8. Flush TX FIFO by writing a '1' to the CLR_TXF bit in the DSPI_MCR, Flush RX FIFO by writing a '1' to the CLR_RXF bit in the DSPI_MCR.
9. Clear transfer count either by setting CTCNT bit in the command word of the first entry in the new queue or via CPU writing directly to SPI_TCNT field in the DSPI_TCR.
10. Enable DMA channel by enabling the DMA enable request for the DMA channel assigned to the DSPI TX FIFO, and RX FIFO by setting the corresponding DMA set enable request bit.
11. Enable serial transmission and serial reception of data by clearing the EOQF bit.

25.5.2 Baud Rate Settings

Table 25-36 shows the baud rate that is generated based on the combination of the baud rate prescaler PBR and the baud rate scaler BR in the DSPI_CTAR registers. The values calculated assume a 100 MHz system frequency and the double baud rate DBR bit is clear.

Table 25-36. Baud Rate Values

| | | Baud Rate Divider Prescaler Values | | | |
|-------------------------|-------|------------------------------------|-------|-------|-------|
| | | 2 | 3 | 5 | 7 |
| Baud Rate Scaler Values | 2 | 25.0M | 16.7M | 10.0M | 7.14M |
| | 4 | 12.5M | 8.33M | 5.00M | 3.57M |
| | 6 | 8.33M | 5.56M | 3.33M | 2.38M |
| | 8 | 6.25M | 4.17M | 2.50M | 1.79M |
| | 16 | 3.12M | 2.08M | 1.25M | 893k |
| | 32 | 1.56M | 1.04M | 625k | 446k |
| | 64 | 781k | 521k | 312k | 223k |
| | 128 | 391k | 260k | 156k | 112k |
| | 256 | 195k | 130k | 78.1k | 55.8k |
| | 512 | 97.7k | 65.1k | 39.1k | 27.9k |
| | 1024 | 48.8k | 32.6k | 19.5k | 14.0k |
| | 2048 | 24.4k | 16.3k | 9.77k | 6.98k |
| | 4096 | 12.2k | 8.14k | 4.88k | 3.49k |
| | 8192 | 6.10k | 4.07k | 2.44k | 1.74k |
| | 16384 | 3.05k | 2.04k | 1.22k | 872 |
| | 32768 | 1.53k | 1.02k | 610 | 436 |

25.5.3 Delay Settings

Table 25-37 shows the values for the Delay after Transfer (t_{DT}) and CS to SCK Delay (T_{CSC}) that can be generated based on the prescaler values and the scaler values set in the DSPI_CTAR registers. The values calculated assume a 100 MHz system frequency.

This table does not apply for TSB Continuous Mode.

Table 25-37. Delay Values

| | | Delay Prescaler Values | | | |
|---------------------|---------------|------------------------|---------------|---------------|---------------|
| | | 1 | 3 | 5 | 7 |
| Delay Scaler Values | 2 | 20.0 ns | 60.0 ns | 100.0 ns | 140.0 ns |
| | 4 | 40.0 ns | 120.0 ns | 200.0 ns | 280.0 ns |
| | 8 | 80.0 ns | 240.0 ns | 400.0 ns | 560.0 ns |
| | 16 | 160.0 ns | 480.0 ns | 800.0 ns | 1.1 μ s |
| | 32 | 320.0 ns | 960.0 ns | 1.6 μ s | 2.2 μ s |
| | 64 | 640.0 ns | 1.9 μ s | 3.2 μ s | 4.5 μ s |
| | 128 | 1.3 μ s | 3.8 μ s | 6.4 μ s | 9.0 μ s |
| | 256 | 2.6 μ s | 7.7 μ s | 12.8 μ s | 17.9 μ s |
| | 512 | 5.1 μ s | 15.4 μ s | 25.6 μ s | 35.8 μ s |
| | 1024 | 10.2 μ s | 30.7 μ s | 51.2 μ s | 71.7 μ s |
| | 2048 | 20.5 μ s | 61.4 μ s | 102.4 μ s | 143.4 μ s |
| | 4096 | 41.0 μ s | 122.9 μ s | 204.8 μ s | 286.7 μ s |
| | 8192 | 81.9 μ s | 245.8 μ s | 409.6 μ s | 573.4 μ s |
| | 16384 | 163.8 μ s | 491.5 μ s | 819.2 μ s | 1.1 ms |
| | 32768 | 327.7 μ s | 983.0 μ s | 1.6 ms | 2.3 ms |
| 65536 | 655.4 μ s | 2.0 ms | 3.3 ms | 4.6 ms | |

25.5.4 Calculation of FIFO Pointer Addresses

The user has complete visibility of the TX and RX FIFO contents through the FIFO registers, and valid entries can be identified through a memory mapped pointer and a memory mapped counter for each FIFO. The pointer to the first-in entry in each FIFO is memory mapped. For the TX FIFO the first-in pointer is the Transmit Next Pointer (TXNXTPTR). For the RX FIFO the first-in pointer is the Pop Next Pointer (POPXTPTR). [Figure 25-42](#) illustrates the concept of first-in and last-in FIFO entries along with the FIFO Counter. The TX FIFO is chosen for the illustration, but the concepts carry over to the RX FIFO. See [Section 25.4.3.4, Transmit First In First Out \(TX FIFO\) Buffering Mechanism](#), and [Section 25.4.3.5, Receive First In First Out \(RX FIFO\) Buffering Mechanism](#), for details on the FIFO operation.

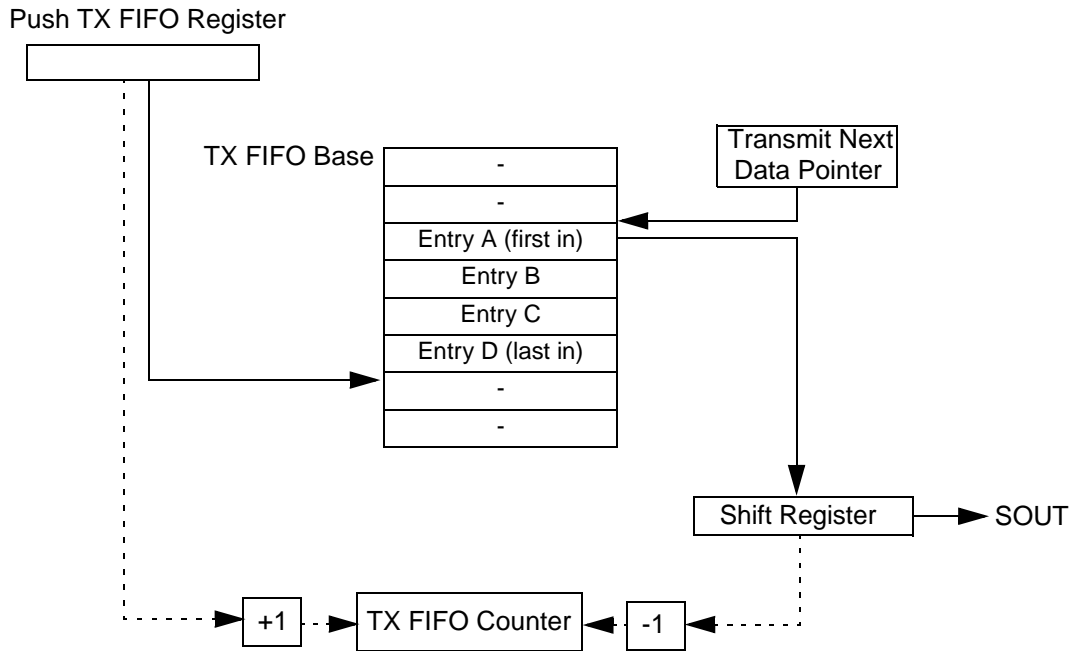

Figure 25-42. TX FIFO Pointers and Counter

25.5.4.1 Address Calculation for the First-in Entry and Last-in Entry in the TX FIFO

The memory address of the first-in entry in the TX FIFO is computed by the following equation:

$$\text{First-in Entry Address} = \text{TX FIFO Base} + (4 \times \text{TXNXTPTR}) \quad \text{Eqn. 25-7}$$

The memory address of the last-in entry in the TX FIFO is computed by the following equation:

$$\text{Last-in Entry address} = \text{TX FIFO Base} + 4 \times \text{modulo TX FIFO depth}(\text{TXCTR} + \text{TXNXTPTR} - 1) \quad \text{Eqn. 25-8}$$

TX FIFO Base - Base address of TX FIFO

TXCTR - TX FIFO Counter

TXNXTPTR - Transmit Next Pointer

TX FIFO Depth - Transmit FIFO depth, implementation specific

25.5.4.2 Address Calculation for the First-in Entry and Last-in Entry in the RX FIFO

The memory address of the first-in entry in the RX FIFO is computed by the following equation:

$$\text{First-in Entry Address} = \text{RX FIFO Base} + (4 \times \text{POPNXTPTR}) \quad \text{Eqn. 25-9}$$

The memory address of the last-in entry in the RX FIFO is computed by the following equation:

$$\text{Last-in Entry address} = \text{RX FIFO Base} + 4 \times \text{modulo RX FIFO depth}(\text{RXCTR} + \text{POPNXTPTR} - 1) \quad \text{Eqn. 25-10}$$

RX FIFO Base - Base address of RX FIFO

RXCTR - RX FIFO counter

POPNEXTPTR - Pop Next Pointer

RX FIFO Depth - Receive FIFO depth, implementation specific



Chapter 26 Enhanced Serial Communication Interface (eSCI)

26.1 Introduction

The eSCI block is an enhanced SCI block with a LIN master interface layer and DMA support. The LIN master layer complies with the specifications LIN 1.3, LIN 2.0, LIN 2.1, and SAE J2602/1.

26.1.1 Bibliography

- LIN Specification Package Revision 1.3; December 12, 2002
- LIN Specification Package Revision 2.0; September 23, 2003
- LIN Network for Vehicle Applications, SAE J2602/1, September 1, 2005
- LIN Specification Package Revision 2.1; November 24, 2006

26.1.2 Acronyms and Abbreviations

Table 26-1 contains acronyms and abbreviations used in this document.

Table 26-1. Acronyms and Abbreviations

| Term | Description |
|--------|--|
| eSCI | Enhanced SCI block with LIN support and DMA support |
| SCI | Serial Communications Interface |
| LIN | Local Interconnect Network - A protocol for low-cost automobile networks |
| LIN PE | LIN Protocol Engine, Finite State Machine to control logic of the LIN hardware. |
| MCLK | Module Clock, defined in Section 26.4.3.1, Module Clock |
| TCLK | Transmitter Clock, defined in Section 26.4.3.2, Transmitter Clock |
| RCLK | Receiver Clock, defined in Section 26.4.3.3, Receiver Clock |
| RSC | Receiver Sample Counter, defined in Section 26.4.3.3, Receiver Clock |

26.1.3 Glossary

Table 26-2. Glossary

| Term | Definition |
|------------------|--|
| Logic level one | The voltage that corresponds to Boolean true (1) state. |
| Logic level zero | The voltage that corresponds to Boolean false (0) state. |

Table 26-2. Glossary (continued)

| Term | Definition |
|----------------|--|
| Set | To set a bit or bits means to establish logic level one on the bit or bits. |
| Clear | To clear a bit or bits means to establish logic level zero on the bit or bits. |
| Asserted | A signal that is asserted is in its active state. An active low signal changes from logic level one to logic level zero when asserted, and an active high signal changes from logic level zero to logic level one. |
| | |
| Preamble | The term preamble describes an idle character which is <i>transmitted</i> by the eSCI module. |
| Bit time | Duration of a single bit in a transmitted byte field or character, equivalent to the duration of one transmitter clock cycle defined in Section 26.4.3.2, Transmitter Clock |
| frame | Entity that consists of the start bit followed by payload bits followed by one ore more stop bits |
| LIN byte field | Special instance of a frame |
| SCI frame | Special instance of a frame |
| LIN frame | Sequence of break character followed by LIN byte fields |
| LIN TX frame | A LIN frame with the frame header, data byte fields, and checksum field transmitted by the eSCI module |
| LIN RX frame | A LIN frame with the header field transmitted by the eSCI module and the data byte fields and checksum field received by the eSCI module |

26.1.4 Overview

The eSCI block allows asynchronous serial communications with peripheral devices and other CPUs. It includes special support to interface to LIN slave devices.

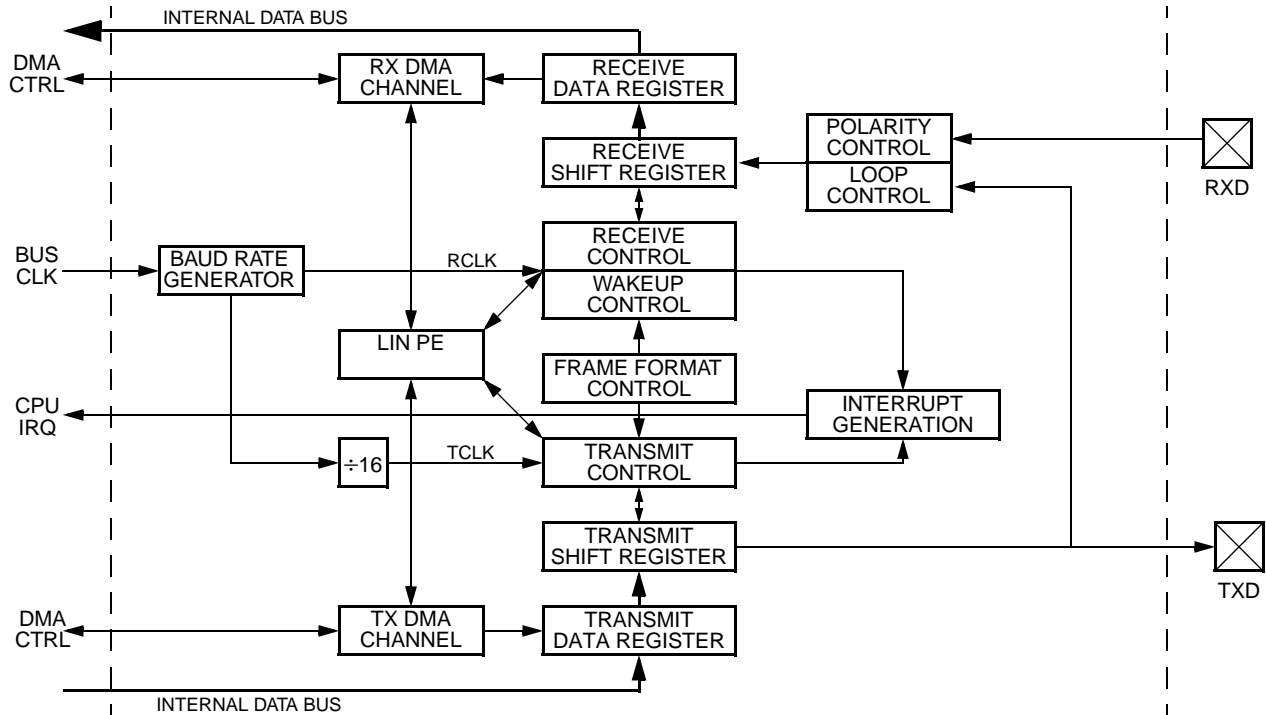

Figure 26-1. eSCI Block Diagram

26.1.5 Features

The eSCI block includes these distinctive features:

- Full-duplex operation
- Standard mark/space non-return-to-zero (NRZ) format
- 13-bit baud rate selection
- Programmable frame, payload, and character format
- Support of 2 stop bits in receiver path
- Hardware parity generation and checking
 - Programmable even or odd parity
- Programmable polarity of RXD pin
- Separately enabled transmitter and receiver
- Two receiver wake up methods:
 - Idle line wake-up
 - Address mark wake-up
- Interrupt-driven operation with eight flags:
 - Transmitter empty
 - Transmission complete
 - Receiver full

- Idle receiver input
- Receiver overrun
- Noise error
- Framing error
- Parity error
- Receiver framing error detection
- 1/16 bit-time noise detection
- 2 channel DMA interface
- LIN support
 - LIN Master Node functionality (master and slave task)
 - Compatible with LIN slaves from revisions 1.x and 2.0 of the LIN standard
 - Detection of Bit Errors, Physical Bus Errors and Checksum Errors
 - All status bit can generate maskable interrupts
 - Application layer CRC support
 - Programmable CRC polynom
 - Detection and generation of wakeup characters
 - Programmable wakeup delimiter time
 - Programmable slave timeout
 - Can be configured to include header bits in checksum
 - LIN DMA interface

26.1.6 Modes of Operation

The eSCI module has two functional operational modes, SCI and LIN mode, and low power modes. The availability of register bits and fields depends on the selected operational mode.

26.1.6.1 SCI Mode

The SCI mode is the default functional operational mode and is described in [Section 26.4.5, SCI Mode](#).

26.1.6.2 LIN Mode

The LIN mode is the second functional operational mode and is described in [Section 26.4.6, LIN Mode](#).

26.1.6.3 Disabled Mode

In the Disabled mode the eSCI module indicates to the clocking system, that all module clocks can be turned off. The eSCI module is in the Disabled Mode, if the MDIS bit in the [Control Register 2 \(eSCI_CR2\)](#) is set.

26.1.6.4 Stop Mode

When the eSCI module is in Stop mode, it is inactive and indicates to the system, that all clocks to the eSCI modules can be turned off.

The system requests the eSCI module to enter the Stop mode by asserting the system stop signal. When this happens, the eSCI module performs a shut down of the ongoing transmission or reception as described in [Section 26.1.6.4.1, Entering Stop Mode from SCI Mode](#), and [Section 26.1.6.4.3, If the eSCI module is in Stop mode and the system stop signal is de-asserted and the LIN bit and the MDIS bit are 0, the eSCI module will enter the SCI mode. The TRDE flag will be set. No data will be transmitted as long as new data provided by the application. If the receiver is still enabled, it starts the detection of the start bit.](#)**Entering Stop Mode from LIN Mode.**

The system requests the eSCI module to leave the Stop mode by de-asserting the system stop signal. When this happens, the eSCI module then enters the operational mode configured by the LIN bit and the MDIS bit. The related sequence is described in [Section 26.1.6.4.2, Leaving Stop Mode into SCI Mode](#), and [Section 26.1.6.4.4, Leaving Stop Mode into LIN Mode](#).

26.1.6.4.1 Entering Stop Mode from SCI Mode

If the eSCI module is in SCI mode and the system stop signal is asserted while a SCI frame or character transmission is running, the eSCI module performs a shut down of the transmit process. Therefore, it continues the ongoing frame or character transmission until the last bit of the SCI frame or character has been transmitted. After the end of the transmission, all pending transfer requests are cleared and no more data will be transmitted. None of the transmitter related register flags will be set

If the eSCI module is in SCI mode and the system stop signal is asserted while a SCI frame or character reception is running, the module stops the reception immediately. None of the receiver related register flags will be set.

If the eSCI module is in SCI mode and the system stop signal is asserted and no transmission or reception is running, the eSCI module will enter the Stop mode.

26.1.6.4.2 Leaving Stop Mode into SCI Mode

26.1.6.4.3 If the eSCI module is in Stop mode and the system stop signal is de-asserted and the LIN bit and the MDIS bit are 0, the eSCI module will enter the SCI mode. The TRDE flag will be set. No data will be transmitted as long as new data provided by the application. If the receiver is still enabled, it starts the detection of the start bit.**Entering Stop Mode from LIN Mode**

If the eSCI module is in LIN mode and the system stop signal is asserted while a LIN byte field or character transmission is running, the eSCI module performs a shut down of the transmit process. Therefore, it continues the ongoing LIN byte field or character transmission until the last bit of the LIN byte field or character has been transmitted. After the end of the transmission, all pending transfer requests are cleared and no more data will be transmitted. None of the transmitter related register flags will be set.

If the eSCI module is in LIN mode and the system stop signal is asserted while a LIN byte field or character reception is running, the eSCI module aborts the reception immediately. None of the receiver related register flags will be set.

If the eSCI module is in LIN mode and the system stop signal is asserted and no transmission or reception is running, the eSCI module resets the LIN protocol engine to its idle state, resets the write access counter of the [LIN Transmit Register \(eSCI_LTR\)](#) and enters the Stop mode.

26.1.6.4.4 Leaving Stop Mode into LIN Mode

If the eSCI module is in Stop mode and the system stop signal is de-asserted and the LIN bit is set and the MDIS bit is 0, the eSCI module will enter the LIN mode. The TXRDY flag will be set. No data will be transmitted as long as new LIN frame header data provided by the application. If the receiver is still enabled, it starts the detection of the start bit.

26.2 External Signal Description

The eSCI module is connected to a total of two external pins.

26.2.1 Detailed Signal Descriptions

26.2.1.1 eSCI Transmit Pin (TXD)

This pin serves as transmit data output and as the receive data input of eSCI.

26.2.1.2 eSCI Receive Pin (RXD)

This pin serves as receive data input of the eSCI.

26.3 Memory Map and Register Definition

This section provides the memory map and a detailed description of the memory mapped registers.

26.3.1 Memory Map

[Table 26-3](#) provides a 32-bit view of the eSCI's memory map. This table gives the register offset w.r.t. module base address eSCI_BASE.

Table 26-3. eSCI 32-bit Memory Map

| Offset | Register | |
|--------|---|---|
| 0x0000 | Baud Rate Register (eSCI_BRR) | Control Register 1 (eSCI_CR1) |
| 0x0004 | Control Register 2 (eSCI_CR2) | SCI Data Register (eSCI_DR) |
| 0x0008 | Interrupt Flag and Status Register 1 (eSCI_IFSR1) | Interrupt Flag and Status Register 2 (eSCI_IFSR2) |

Table 26-3. eSCI 32-bit Memory Map (continued)

| Offset | Register | |
|--------|--|------------------------------------|
| 0x000C | LIN Control Register 1 (eSCI_LCR1) | LIN Control Register 2 (eSCI_LCR2) |
| 0x0010 | LIN Transmit Register (eSCI_LTR) | Reserved |
| 0x0014 | LIN Receive Register (eSCI_LRR) | Reserved |
| 0x0018 | LIN CRC Polynomial Register (eSCI_LPR) | Control Register 3 (eSCI_CR3) |
| 0x001C | Reserved | |

Table 26-4 provides a key for register figures and tables.

Table 26-4. Register Conventions

| Convention | Description |
|-----------------------------|---|
| | Depending on its placement in the read or write row, indicates that the bit is not readable or not writeable. |
| FIELDNAME | Identifies the field. Its presence in the read or write row indicates that it can be read or written. |
| Register Field Types | |
| rwm | A read/write bit that may be modified by a eSCI module in some fashion other than by a reset. |
| w1c | Write one to clear. A flag bit that can be read, is cleared by writing a one, writing 0 has no effect. |
| Reset Values | |
| 0 | Resets to zero. |
| 1 | Resets to one. |

26.3.2 Register Descriptions

This section consists of register descriptions in address order. Each description includes a standard register diagram with an associated figure number. Writes to a reserved register location do not have any effect and reads of these locations return a zero. Details of register bit and field function follow the register diagrams, in bit order.

26.3.2.1 Baud Rate Register (eSCI_BRR)

eSCI_BASE + 0x0000

Write: Anytime

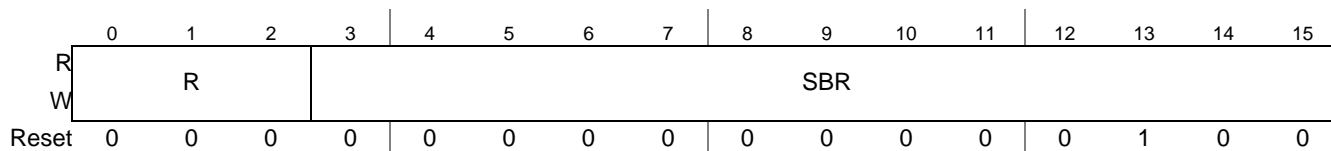

Figure 26-2. Baud Rate Register (eSCI_BRR)

This register provides the control value for the serial baud rate. The baud rate and clock generation is specified in [Section 26.4.3, Baud Rate and Clock Generation](#).

A byte write access to only the upper byte of this register (eSCI_BRR[0:7]) will not change the content of the register, instead, the written byte is stored internally into a shadow register. A subsequent byte write access to only the lower byte of this register (eSCI_BRR[8:15]) updates the lower byte and copies the content of the shadow register into the upper byte.

A byte write access to only the lower byte of this register (eSCI_BRR[8:0]) without a preceding byte write access to only the upper byte copies a value of all zero into the upper byte.

A word write access to this register updates both the lower and upper byte immediately and is the recommended write access type for this register.

Table 26-5. eSCI_BRR Field Descriptions

| Field | Description |
|-------|--|
| R | Reserved. These bits are reserved. They are read as 0. Application must not write 1 to these bits. |
| SBR | Serial Baud Rate. This field provides the baud rate control value SBR. |

26.3.2.2 Control Register 1 (eSCI_CR1)

eSCI_BASE + 0x0002

Write: Anytime

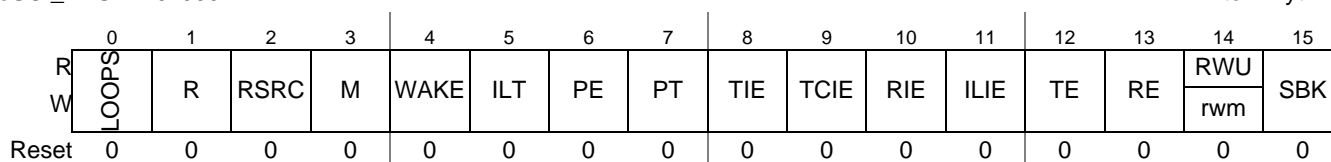

Figure 26-3. Control Register 1 (eSCI_CR1)

This register provides bits to configure the functionality of the module, provides the interrupt enable bits for the interrupt flags provided in [Interrupt Flag and Status Register 1 \(eSCI_IFSR1\)](#) and provides the control bits for the transmitter and receiver.

Table 26-6. eSCI_CR1 Field Descriptions

| Field | Description |
|-------|--|
| LOOPS | Loop Mode Select. This control bit together with the RSRC control bit defines the receiver source mode. The mode coding is defined in Table 26-7 and the modes are described in Section 26.4.5.3.2, Receiver Input Mode Selection . |
| R | Reserved. This bit is reserved. It is read as 0. Application must not write 1 to these bits. |
| RSRC | Receiver Source Control. This control bit together with the LOOPS control bit defines the receiver source mode. The mode coding is defined in Table 26-7 and the modes are described in Section 26.4.5.3.2, Receiver Input Mode Selection . |
| M | Frame Format Mode. This control bit together with the M2 bit of the Control Register 3 (eSCI_CR3) controls the frame format used. The supported frame formats and the related settings are defines in Section 26.4.2, Frame Formats . |
| WAKE | Receiver Wake-up Condition. This control bit defines the wake-up condition for the receiver. The receiver wake-up is described in Section 26.4.5.5, Multiprocessor Communication . 0 Idle line wake-up. 1 Address mark wake-up |
| ILT | Idle Line Type. This control bit defines the type of idle line detection for the receiver wake-up. The two types are described in Section 26.4.5.5.1, Idle-Line Wakeup . 0 Idle line detection starts after reception of a low bit. 1 Idle line detection starts after reception of the last stop bit. |
| PE | Parity Enable. This control bit enables the parity bit generation and checking. The location of the parity bits is shown in Section 26.4.2, Frame Formats . 0 Parity bit generation and checking disabled. 1 Parity bit generation and checking enabled. |
| PT | Parity Type. This control bit defines whether even or odd parity has to be used. 0 Even parity (even number of ones in character clears the parity bit). 1 Odd parity (odd number of ones in character clears the parity bit). |
| TIE | Transmitter Interrupt Enable. This bit controls the eSCI_IFSR1[TRDE] interrupt request generation. 0 TDRE interrupt request generation disabled. 1 TDRE interrupt request generation enabled. |
| TCIE | Transmission Complete Interrupt Enable. This bit controls the eSCI_IFSR1[TC] interrupt request generation. 0 TC interrupt request generation disabled. 1 TC interrupt request generation enabled. |
| RIE | Receiver Full Interrupt Enable. This bit controls the eSCI_IFSR1[RDRF] interrupt request generation. 0 RDRF interrupt request generation disabled. 1 RDRF interrupt request generation enabled. |
| ILIE | Idle Line Interrupt Enable. This bit controls the eSCI_IFSR1[IDLE] interrupt request generation. 0 IDLE interrupt request generation disabled. 1 IDLE interrupt request generation enabled. |
| TE | Transmitter Enable. This control bit enables and disables the transmitter. The control features of the transmitter are described in Section 26.4.5.2.1, Transmitter States and Transitions . 0 Transmitter disabled. 1 Transmitter enabled. |
| RE | Receiver Enable. This control bit enables and disables the receiver. The control features of the receiver are described in Section 26.4.5.3.1, Receiver States and Transitions . 0 Receiver disabled. 1 Receiver enabled. |

Table 26-6. eSCI_CR1 Field Descriptions (continued)

| Field | Description |
|-------|--|
| RWU | Receiver Wake-Up Mode. This bit controls and indicates the receiver wake-up mode, which is described in Section 26.4.5.5, Multiprocessor Communication . 0 Normal receiver operation. 1 Receiver is in wake-up mode. Note: This bit should be set in SCI mode only. |
| SBK | Send Break Character. This bit controls the transmission of break characters, which is described in Section 26.4.5.2.7, Break Character Transmission . 0 No break characters will be transmitted. 1 Break characters will be transmitted. Note: This bit should be set in SCI mode only. |

Table 26-7. Receive Source Mode Selection

| LOOPS | RSCR | Receiver Input Mode |
|-------|------|---------------------|
| 0 | 0 | Dual Wire Mode |
| 0 | 1 | Reserved |
| 1 | 0 | Loop Mode |
| 1 | 1 | Single Wire Mode |

26.3.2.3 Control Register 2 (eSCI_CR2)

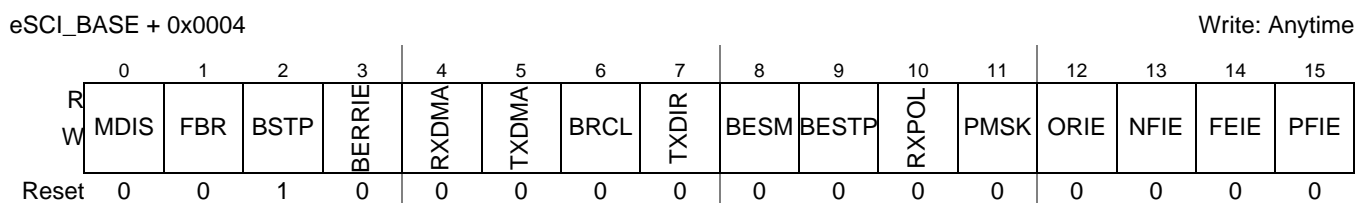

Figure 26-4. Control Register 2 (eSCI_CR2)

This register provides bits to configure the functionality of the module, and interrupt enable bits for the interrupt flags provided in [Interrupt Flag and Status Register 1 \(eSCI_IFSR1\)](#) and control bits for the transmitter and receiver.

Table 26-8. eSCI_CR2 Field Descriptions

| Field | Description |
|-------|--|
| MDIS | Module Disabled Mode. This bit controls the Module Mode of Operation, which is described in Section 26.1.6, Modes of Operation . 0 Module is not in Disabled Mode. 1 Module is in Disabled Mode. |
| FBR | Fast Bit Error Detection. This bit controls the Bit Error Detection mode. 0 Standard Bit error detection performed as described in Section 26.4.6.5.3, Standard Bit Error Detection . 1 Fast Bit error detection performed as described in Section 26.4.6.5.4, Fast Bit Error Detection . Note: This bit is used in LIN mode only. |

Table 26-8. eSCI_CR2 Field Descriptions (continued)

| Field | Description |
|--------|---|
| BSTP | <p>DMA Stop on Bit Error or Physical Bus Error. This bit controls the transmit DMA requests generation in case of bit errors or physical bus errors. Bit errors are indicated by the BERR flag in the Interrupt Flag and Status Register 1 (eSCI_IFSR1) and physical bus errors are indicated by the PBERR flag in the Interrupt Flag and Status Register 2 (eSCI_IFSR2).</p> <p>0 Transmit DMA requests generated regardless of bit errors or physical bus errors. 1 Transmit DMA requests are <i>not</i> generated if eSCI_IFSR1[BERR] flag or eSCI_IFSR2[PBERR] flags are set. Note: This bit is used in LIN mode only.</p> |
| BERRIE | <p>Bit Error Interrupt Enable. This bit controls the BERR interrupt request generation.</p> <p>0 BERR interrupt request generation disabled. 1 BERR interrupt request generation enabled.</p> |
| RXDMA | <p>Receive DMA Control. This bit enables the receive DMA feature.</p> <p>0 Receive DMA disabled. 1 Receive DMA enabled.</p> |
| TXDMA | <p>Transmit DMA Control. This bit enables the transmit DMA feature.</p> <p>0 Transmit DMA disabled. 1 Transmit DMA enabled.</p> |
| BRCL | <p>Break Character Length. This bit is used to define the length of the break character to be transmitted. The settings are specified in Section 26.4.2.2, Break Character Formats.</p> |
| TXDIR | <p>TXD pin output enable. This bit determines whether the TXD pin is used as an output.</p> <p>0 TXD pin is not used as output. 1 TXD pin is used as output. Note: This bit is used in Single Wire Mode only.</p> |
| BESM | <p>Fast Bit Error Detection Sample Mode. This bit defines the sample point for the Fast Bit Error Detection Mode.</p> <p>0 Sample point is RS9. 1 Sample point is RS13. Note: This bit is used in LIN mode only.</p> |
| BESTP | <p>Transmit Stop on Bit Error. If this control bit is set, the eSCI stops driving the LIN bus immediately when a Bit Error has been detected, i.e. eSCI_IFSR1[BERR]=1. Additionally, the eSCI will not start a new byte transmission as long the BERR interrupt flag is set.</p> <p>0 Transmission is not stopped on bit error. 1 Transmission is stopped on bit error. Note: This bit is used in LIN mode only.</p> |
| RXPOL | <p>RXD Pin polarity. This bit controls the polarity of the RXD pin. See Section 26.4.2.1.1, Inverted Data Frame Formats</p> <p>0 Normal Polarity. 1 Inverted Polarity.</p> |
| PMSK | <p>Parity Bit Masking. This bit defines whether the received parity bit is presented in the related bit position in the SCI Data Register (ESCI_DR).</p> <p>0 The received parity bit is presented in the bit position related to the parity bit. 1 The value 0 is presented in the bit position related to the parity bit.</p> |
| ORIE | <p>Overrun Interrupt Enable. This bit controls the eSCI_IFSR1[OR] interrupt request generation.</p> <p>0 OR interrupt request generation disabled. 1 OR interrupt request generation enabled.</p> |
| NFIE | <p>Noise Interrupt Enable. This bit controls the eSCI_IFSR1[NF] interrupt request generation.</p> <p>0 NF interrupt request generation disabled. 1 NF interrupt request generation enabled.</p> |

Table 26-8. eSCI_CR2 Field Descriptions (continued)

| Field | Description |
|-------|--|
| FEIE | Frame Error Interrupt Enable. This bit controls the eSCI_IFSR1[FE] interrupt request generation. 0 FE interrupt request generation disabled. 1 FE interrupt request generation enabled. |
| PFIE | Parity Error Interrupt Enable. This bit controls the eSCI_IFSR1[PF] interrupt request generation. 0 PF interrupt request generation disabled. 1 PF interrupt request generation enabled. |

26.3.2.4 SCI Data Register (ESCI_DR)

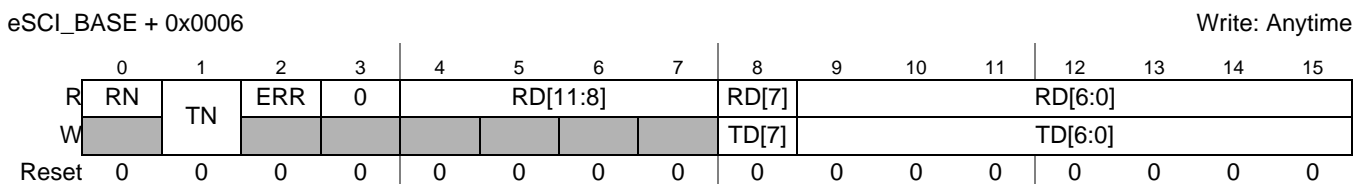

Figure 26-5. SCI Data Register (ESCI_DR)

This register is used to provide transmit data and retrieve received data in SCI mode. In LIN mode any write access to this register is ignored and any read access returns all 0. In case of data transmission this register is used to provide a part of the transmit data. In case of data reception this register provides a part of the received data and related error information. If the application writes to the lower byte of this register (ESCI_DR[8:15]), the internal commit flag iCMT, which is not visible to the application, is set to indicate that the register has been updated and ready to transmit new data.

If the application reads from the lower byte of this register (ESCI_DR[8:15]), a signal is sent to the internal receiver unit to indicate that the register was read and is ready to receive new data. The read access will not change the content of any register.

Table 26-9. ESCI_DR Field Descriptions

| Field | Description |
|-------|--|
| RN | Received Most Significant Bit. The semantic of this bit depends on the frame format selected by eSCI_CR3[M2], eSCI_CR1[M], and eSCI_CR1[PE]. [M2=0,M=1,PE=0]: value of received data bit 8 or address bit. [M2=0,M=1,PE=1]: value of received parity bit if eSCI_CR2[PMSK]=0, 0 otherwise. [M2=1,M=0,PE=1]: value of received parity bit if eSCI_CR2[PMSK]=0, 0 otherwise. [M2=1,M=1,PE=1]: value of received parity bit if eSCI_CR2[PMSK]=0, 0 otherwise. It is 0 for all other frame formats. |
| TN | Transmit Most Significant Bit. The semantic of this bit depends on the frame format selected by eSCI_CR3[M2], eSCI_CR1[M], and eSCI_CR1[PE]. [M2=0,M=1,PE=0]: value to be transmitted as data bit 8 or address bit. It is not used for all other frame formats. |
| ERR | Receive Error Bit. This bit indicates the occurrence of the errors selected by the Control Register 3 (eSCI_CR3) during the reception of the frame presented in SCI Data Register (ESCI_DR) . In case of an overrun error for subsequent frames this bit is set too. 0 None of the selected errors occurred. 1 At least one of the selected errors occurred. |

Table 26-9. ESCI_DR Field Descriptions (continued)

| Field | Description |
|----------|--|
| RD[11:8] | Received Data. The semantic of this field depends on the frame format selected by eSCI_CR3[M2] and eSCI_CR1[M]. [M2=1,M=1]: value of the received data bits 11:8. (Rx=BITx). It is all 0 for all other frame formats. |
| RD[7] | Received Bit 7. The semantic of this bit depends on the format selected by eSCI_CR3[M2], eSCI_CR1[M], and eSCI_CR1[PE]. [M2=0,M=0,PE=0]: value of received BIT7 or ADDR BIT. [M2=0;M=0,PE=1]: value of received PARITY BIT if eSCI_CR2[PMSK]=0, 0 otherwise. For all other frame formats it is the value of received BIT7. |
| TD[7] | Transmit Bit 7. The semantic of this bit depends on the format selected by eSCI_CR3[M2], eSCI_CR1[M], and eSCI_CR1[PE]. [M2=0,M=0,PE=0]: value of transmit BIT7 or ADDR BIT. [M2=0;M=0,PE=1]: not used. PARITY BIT is generated internally before transmission. For all other frame formats it is the value of transmit BIT7. |
| RD[6:0] | Received bits 6 to 0. Value of received BITx is shown in bit Rx |
| TD[6:0] | Transmit bits 6 to 0. Value of bit Tx is transmitted in BITx. |

26.3.2.5 Interrupt Flag and Status Register 1 (eSCI_IFSR1)

eSCI_BASE + 0x0008

Write: Anytime

| | 0 | 1 | 2 | 3 | 4 | 5 | 6 | 7 | 8 | 9 | 10 | 11 | 12 | 13 | 14 | 15 |
|-------|------|-----|------|------|-----|-----|-----|-----|---|---|----|------|----|----|------|------|
| R | TDRE | TC | RDRF | IDLE | OR | NF | FE | PF | | | | BERR | | | TACT | RACT |
| W | w1c | w1c | w1c | w1c | w1c | w1c | w1c | w1c | | | | w1c | | | | |
| Reset | 0 | 0 | 0 | 0 | 0 | 0 | 0 | 0 | 0 | 0 | 0 | 0 | 0 | 0 | 0 | 0 |

Figure 26-6. Interrupt Flag and Status Register 1 (eSCI_IFSR1)

This register provides interrupt flags that indicate the occurrence of module events. The related interrupt enable bits are located in [Control Register 1 \(eSCI_CR1\)](#) and [Control Register 2 \(eSCI_CR2\)](#).

Table 26-10. eSCI_IFSR1 Field Descriptions

| Field | Description |
|-------|---|
| TDRE | Transmit Data Register Empty Interrupt Flag. This interrupt flag is set when the content of the SCI Data Register (ESCI_DR) was transferred into internal shift register. Note: This flag is set in SCI mode only. |
| TC | Transmit Complete Interrupt Flag. This interrupt flag is set when a frame, break or idle character transmission has been completed and no data were written into SCI Data Register (ESCI_DR) after the last setting of the TDRE flag and the SBK bit in Control Register 1 (eSCI_CR1) is 0. This flag is set in LIN mode, if the preamble was transmitted after the enabling of the transmitter. |
| RDRF | Receive Data Register Full Interrupt Flag. This interrupt flag is set when the payload data of a received frame was transferred into the SCI Data Register (ESCI_DR) . Note: This flag is set in SCI mode only. |
| IDLE | Idle Line Interrupt Flag. This interrupt flag is set when an idle character was detected and the receiver is not in the wakeup state. Note: This flag is set in SCI mode only. |

Table 26-10. eSCI_IFSR1 Field Descriptions (continued)

| Field | Description |
|-------|---|
| OR | Overrun Interrupt Flag. This interrupt flag is set when an overrun was detected as described in Section 26.4.5.3.11, Receiver Overrun . Note: This flag is set in SCI mode only. |
| NF | Noise Interrupt Flag. This interrupt flag is set when the payload data of a received frame was transferred into the SCI Data Register (ESCI_DR) or LIN Receive Register (eSCI_LRR) and the receiver has detected noise during the reception of that frame, as described in Section 26.4.5.3.13, Bit Sampling . |
| FE | Framing Error Interrupt Flag. This interrupt flag is set when the payload data of a received frame was transferred into the SCI Data Register (ESCI_DR) or LIN Receive Register (eSCI_LRR) and the receiver has detected a framing error during the reception of that frame, as described in Section 26.4.5.3.18, Stop Bit Verification . |
| PF | Parity Error Interrupt Flag. This interrupt flag is set when the payload data of a received frame was transferred into the SCI Data Register (ESCI_DR) and the receiver has detected a parity error for the character, as described in Section 26.4.5.4, Reception Error Reporting . Note: This flag is set in SCI mode only. |
| BERR | Bit Error Interrupt Flag. This flag is set when a bit error was detected as described in Section 26.4.6.5.3, Standard Bit Error Detection . Note: This flag is set in LIN mode only. |
| TACT | Transmitter Active. The status bit is set as long as the transmission of a frame or special character is ongoing. 0 No transmission in progress. 1 Transmission in progress. |
| RACT | Receiver Active. The bit will be set 3 receiver clock (RCLK) cycles after the successful qualification of a start bit. This bit will be cleared, when an idle character was detected. 0 No reception in progress. 1 Reception in progress. |

26.3.2.6 Interrupt Flag and Status Register 2 (eSCI_IFSR2)

eSCI_BASE + 0x000A

Write: Anytime

| | | | | | | | | | | | | | | | | |
|-------|-------|-------|-------|-----|-------|------|-------|-----|---|---|----|----|----|----|------|------|
| | 0 | 1 | 2 | 3 | 4 | 5 | 6 | 7 | 8 | 9 | 10 | 11 | 12 | 13 | 14 | 15 |
| R | RXRDY | TXRDY | LWAKE | STO | PBERR | CERR | CKERR | FRC | 0 | 0 | 0 | 0 | 0 | 0 | UREQ | OVFL |
| W | w1c | w1c | w1c | w1c | w1c | w1c | w1c | w1c | | | | | | | w1c | w1c |
| Reset | 0 | 0 | 0 | 0 | 0 | 0 | 0 | 0 | 0 | 0 | 0 | 0 | 0 | 0 | 0 | 0 |

Figure 26-7. Interrupt Flag and Status Register 2 (eSCI_IFSR2)

This register provides interrupt flags that indicate the occurrence of LIN related events. The related interrupt enable bits are located in [LIN Control Register 1 \(eSCI_LCR1\)](#) and [LIN Control Register 2 \(eSCI_LCR2\)](#). All interrupt flags in this register will be set in LIN mode only.

Table 26-11. eSCI_IFSR2 Field Descriptions

| Field | Description |
|-------|---|
| RXRDY | Receive Data Ready Interrupt Flag. This interrupt flag is set when the payload data of a received frame was transferred into the LIN Receive Register (eSCI_LRR) . |
| TXRDY | Transmit Data Ready Interrupt Flag. This interrupt flag is set when the content of the LIN Transmit Register (eSCI_LTR) was process by the LIN PE either to generate a frame header or to transmit frame data. |
| LWAKE | LIN Wakeup Received Interrupt Flag. This interrupt flag is set when a LIN Wakeup character was received, as described in Section 26.4.6.6, LIN Wakeup . |
| STO | Slave Timeout Interrupt Flag. This interrupt flag is set when a Slave-Not-Responding-Error is detected. A detailed description is given in Section 26.4.6.5.5, Slave-Not-Responding-Error Detection . |
| PBERR | Physical Bus Error Interrupt Flag. This interrupt flag is set when the receiver input remains unchanged for at least 31 RCLK clock cycles after the start of a byte transmission, as described in Section 26.4.6.5, LIN Error Reporting . |
| CERR | CRC Error Interrupt Flag. This interrupt flag is set when an incorrect CRC pattern was detected for a received LIN frame. |
| CKERR | Checksum Error Interrupt Flag. This interrupt flag is set when a checksum error was detected for a received LIN frame. |
| FRC | Frame Complete Interrupt Flag. This interrupt flag is set when a LIN TX frame has been completely transmitted or a LIN RX frame has been completely received. |
| UREQ | Unrequested Data Received Interrupt Flag. This interrupt flag is set when unrequested activity has been detected on the LIN bus, as described in Section 26.4.6.5, LIN Error Reporting . |
| OVFL | Overflow Interrupt Flag. This interrupt flag is set when an overflow as described in Section 26.4.6.5.8, Overflow Detection was detected. |

26.3.2.7 LIN Control Register 1 (eSCI_LCR1)

eSCI_BASE + 0x000C

Write: Anytime

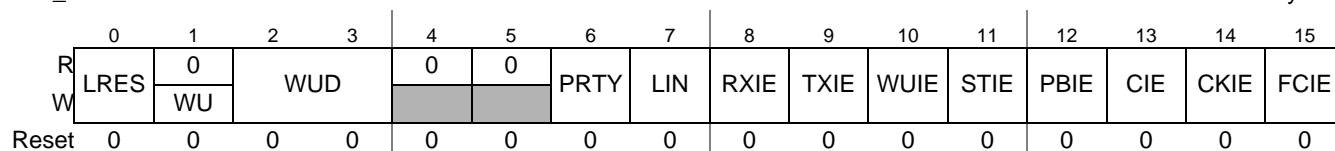

Figure 26-8. LIN Control Register 1 (eSCI_LCR1)

This register provides control bits to control and configure the LIN hardware. This register provides the interrupt enable bits for the interrupt flags in [Interrupt Flag and Status Register 2 \(eSCI_IFSR2\)](#).

Table 26-12. eSCI_LCR1 Field Descriptions

| Field | Description |
|-------|---|
| LRES | LIN Protocol Engine Reset. This bit controls the mode of the LIN protocol engine. 0 LIN protocol engine in operational mode. 1 LIN protocol engine forced into idle state. |
| WU | LIN Bus Wake-Up Trigger. This bit is used to trigger the generation of a wake-up signal on the LIN bus, as described in Section 26.4.6.6, LIN Wakeup . 0 Write has no effect. 1 Write triggers the generation of a wakeup signal. |
| WUD | LIN Bus Wake-Up Delimiter Time. This field determines how long the LIN protocol engine waits after the end of the transmitted wakeup signal, before starting the next LIN frame transmission. 00 4 bit times. 01 8 bit times. 10 32 bit times. 11 64 bit times. |
| PRTY | Parity Generation Control. This bit controls the generation of the two parity bits in the LIN header. 0 Parity bits generation disabled. 1 Parity bits generation enabled. |
| LIN | LIN Mode Control. This bit controls whether the device is in SCI or LIN Mode. 0 SCI Mode. 1 LIN Mode. |
| RXIE | Receive Data Ready Interrupt Enable. This bit controls the eSCI_IFSR2[RXRDY] interrupt request generation. 0 RXRDY interrupt request generation disabled. 1 RXRDY interrupt request generation enabled. |
| TXIE | Transmit Data Ready Interrupt Enable. This bit controls the eSCI_IFSR2[TXRDY] interrupt request generation. 0 TXRDY interrupt request generation disabled. 1 TXRDY interrupt request generation enabled. |
| WUIE | LIN Wakeup Received Interrupt Enable. This bit controls the eSCI_IFSR2[LWAKE] interrupt request generation. 0 LWAKE interrupt request generation disabled. 1 LWAKE interrupt request generation enabled. |
| STIE | Slave Timeout Flag Interrupt Enable. This bit controls the eSCI_IFSR2[STO] interrupt request generation. 0 STO interrupt request generation disabled. 1 STO interrupt request generation enabled. |
| PBIE | Physical Bus Error Interrupt Enable. This bit controls the eSCI_IFSR2[PBERR] interrupt request generation. 0 PBERR interrupt request generation disabled. 1 PBERR interrupt request generation enabled. |
| CIE | CRC Error Interrupt Enable. This bit controls the eSCI_IFSR2[CERR] interrupt request generation. 0 CERR interrupt request generation disabled. 1 CERR interrupt request generation enabled. |
| CKIE | Checksum Error Interrupt Enable. This bit controls the eSCI_IFSR2[CKERR] interrupt request generation. 0 CKERR interrupt request generation disabled. 1 CKERR interrupt request generation enabled. |
| FCIE | Frame Complete Interrupt Enable. This bit controls the eSCI_IFSR2[FRC] interrupt request generation. 0 FRC interrupt request generation disabled. 1 FRC interrupt request generation enabled. |

26.3.2.8 LIN Control Register 2 (eSCI_LCR2)

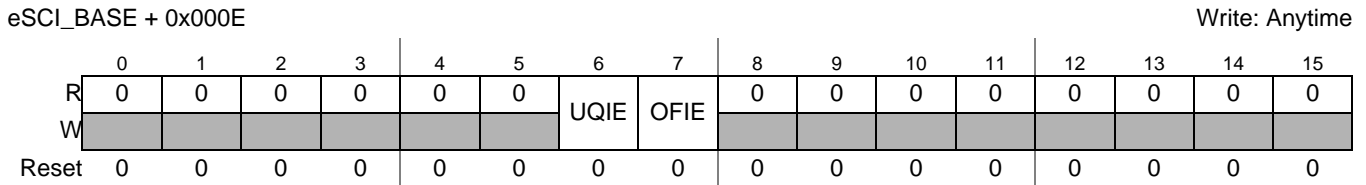

Figure 26-9. LIN Control Register 2 (eSCI_LCR2)

This register provides the interrupt enable bits for the interrupt flags in [Interrupt Flag and Status Register 2 \(eSCI_IFSR2\)](#).

Table 26-13. eSCI_LCR2 Field Descriptions

| Field | Description |
|-------|---|
| UQIE | Unrequested Data Received Interrupt Enable. This bit controls the eSCI_IFSR2[UREQ] interrupt request generation. 0 UREQ interrupt request generation disabled. 1 UREQ interrupt request generation enabled. |
| OFIE | Overflow Interrupt Enable. This bit controls the eSCI_IFSR2[OVFL] interrupt request generation. 0 OVFL interrupt request generation disabled. 1 OVFL interrupt request generation enabled. |

26.3.2.9 LIN Transmit Register (eSCI_LTR)

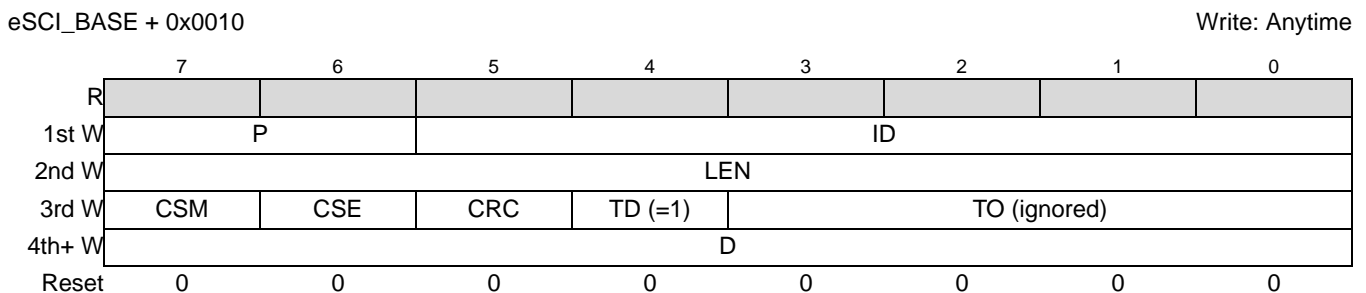

Figure 26-10. LIN Transmit Register (eSCI_LTR) - LIN TX frame generation

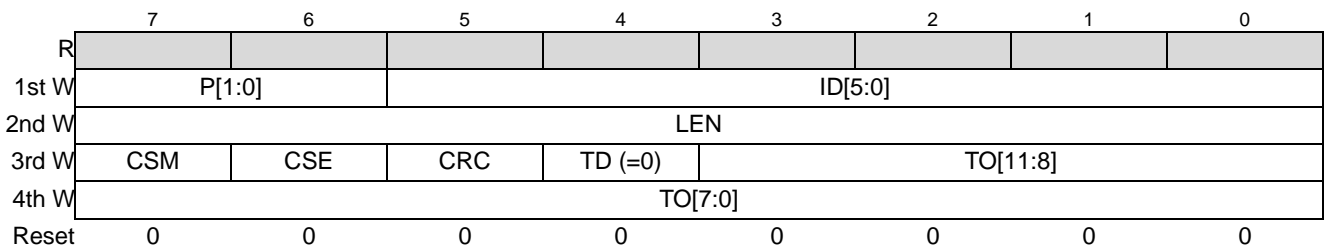

Figure 26-11. LIN Transmit Register (eSCI_LTR) - LIN RX frame generation

This register is used by the application to initiate the LIN frame header generation for both LIN TX frames and LIN RX frames. If a LIN TX frame is generated, this register is used to provide the payload data for the LIN TX frame.

If the application initiates a LIN TX frame transfer, i.e the TD bit is set to 1, the content and usage shown in [LIN Transmit Register \(eSCI_LTR\) - LIN TX frame generation](#) applies. The initiation and transmit of a TX frame is described in [Section 26.4.6.3, LIN TX Frame generation](#).

If the application initiates an LIN RX frame, i.e the TD bit is set to 0, the content and usage shown in [LIN Transmit Register \(eSCI_LTR\) - LIN RX frame generation](#) applies. The initiation and transmit of a RX frame is described in [Section 26.4.6.4, LIN RX frame generation](#).

Each write access to this register increments the internal write access counter and enables the writing to the next field. The write access counter is reset if

- the LIN PE is in the idle state (eSCI_LCR1[LRES] = 1)
- a LIN TX frame was completely transmitted (eSCI_IFSR1[FRC] was set to 1)
- a LIN RX frame was completely received (eSCI_IFSR1[FRC] was set to 1)
- module has entered Stop Mode.

Table 26-14. eSCI_LTR Field Descriptions

| Field | Description |
|-------|--|
| P | Identifier Parity. This field provides the identifier parity which is used to create the protected identifier if the automatic identifier parity generation is disabled, i.e the PRTY bit in LIN Control Register 1 (eSCI_LCR1) is 0. |
| ID | Identifier. This field is used for the identifier field in the protected identifier. |
| LEN | Frame Length. This field defines the number of data bytes to be transmitted or received. |
| CSM | Checksum Model. This bit controls the checksum calculation model used. 0 Classic Checksum Model (LIN 1.3). 1 Enhanced Checksum Model (LIN 2.0). |
| CSE | Checksum Enable. This bit control the generation and checking of the checksum byte. 0 No generation and checking of checksum byte. 1 Generation and checking of checksum byte. |
| CRC | CRC Enable. This bit controls the generation of checking standard or enhanced LIN frames, which are described in Section 26.4.6.2, LIN frame formats . 0 Standard LIN frame generation and checking. 1 Enhanced LIN frame generation and checking. |
| TD | Transfer Direction. This bit control the transfer direction of the data, crc, and checksum byte fields. 0 Data, CRC, and Checksum byte fields received, described in Section 26.4.6.4, LIN RX frame generation . 1 Data, CRC, and Checksum byte fields transmitted, described in Section 26.4.6.3, LIN TX Frame generation . |
| TO | Timeout Value. The content of the field depends on the transfer direction. RX frame: Defines the time available for a complete RX frame transfer, as described in Section 26.4.6.5.4, Fast Bit Error Detection . TX frame: Must be set to 0. |
| D | Transmit Data. Data bits for transmission. |

26.3.2.10 LIN Receive Register (eSCI_LRR)

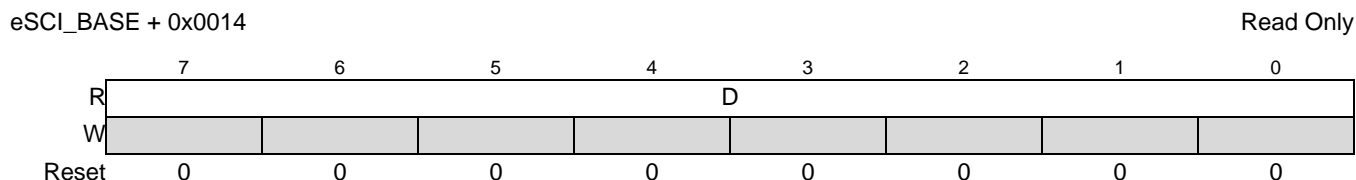

Figure 26-12. LIN Receive Register (eSCI_LRR)

This register provides the data bytes of received in case of an LIN RX frame was initiated.

Table 26-15. eSCI_LRR Field Descriptions

| Field | Description |
|-------|---|
| D | Receive Data. This field provides the data bytes of received LIN RX frames. |

26.3.2.11 LIN CRC Polynomial Register (eSCI_LPR)

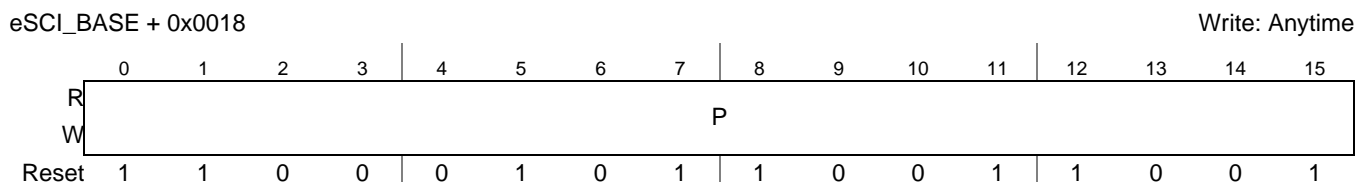

Figure 26-13. LIN CRC Polynomial Register (eSCI_LPR)

This register provides the CRC polynom for generation and processing of CRC-enhanced LIN frames.

Table 26-16. eSCI_LPR Field Descriptions

| Field | Description |
|-------|---|
| P | Polynomial bit $x^{P[n]}$. Used to define the LIN polynomial. Reset value results in $x^{15} + x^{14} + x^{10} + x^8 + x^7 + x^4 + x^3 + 1$, which is the polynomial used for the CAN protocol. |

26.3.2.12 Control Register 3 (eSCI_CR3)

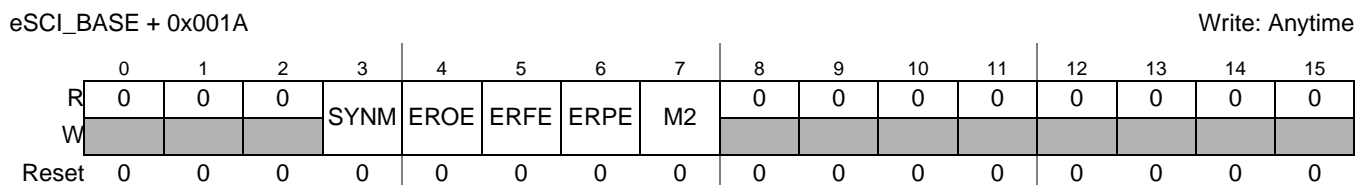

Figure 26-14. Control Register 3 (eSCI_CR3)

This register is used to control the frame formats and the generation of the ERR bit in the [SCI Data Register \(eSCI_DR\)](#).

Table 26-17. eSCI_CR3 Field Descriptions

| Field | Description |
|-----------|---|
| 4 SYNM | Synchronization Mode. This bit controls the synchronization mode of the receiver. The synchronization modes are described in Section 26.4.5.3.14, Bit Synchronization . 0 Synchronization performed at falling start and data bit edge. 1 Synchronization performed at falling start bit edge only. |
| 3 EROE | ERR flag overrun enable. 0 ESCI_DR[ERR] flag not affected by overrun detection. 1 ESCI_DR[ERR] flag is set on overrun detection during frame reception. |
| 2 ERFE | ERR flag frame error enable. 0 ESCI_DR[ERR] flag not affected by frame error detection. 1 ESCI_DR[ERR] flag is set on frame error detection for the data provided in ESCI_DR. |
| 1 ERPE | ERR flag parity error enable. 0 ESCI_DR[ERR] flag not affected by parity error detection. 1 ESCI_DR[ERR] flag is set on parity error detection for the data provided in ESCI_DR. |
| 0 M2 | Frame Format Mode 2. This control bit together with the M bit of the Control Register 1 (eSCI_CR1) controls the frame format used. The supported frame formats and the related settings are defines in Section 26.4.2, Frame Formats . |

26.4 Functional Description

This section provides a complete functional description of the eSCI block, detailing the operation of the design from the end user perspective in a number of subsections.

26.4.1 Module Control

The operational mode of the module is controlled by the MDIS bit in the [Control Register 2 \(eSCI_CR2\)](#). The module can transmit and receives data when it is enabled, i.e MDIS=0.

26.4.2 Frame Formats

The eSCI module uses the standard NRZ mark/space data format. The eSCI supports three basic frame types, which are the data frames, break characters, and idle characters.

26.4.2.1 Data Frame Formats

Each data frame contains a character that is surrounded by a start bit, an optional parity or address bit, and one or two stop bits. The supported data frame formats for transmission and reception are specified in [Table 26-18](#). The supported data frame formats for reception only are specified in [Table 26-19](#).

Table 26-18. Supported Data Frame Formats for RX and TX

| Control | | | | Frame Content | | | | |
|--|----------|----|------|---------------|----------------|---------------------------|-------------|-----------|
| eSCI_CR3 | eSCI_CR1 | | | Start Bits | Payload Bits | | | Stop Bits |
| M2 | M | PE | WAKE | | Character Bits | Address Bits ¹ | Parity Bits | |
| LIN byte fields (Figure 26-15) | | | | | | | | |
| 0 | 0 | 0 | 0 | 1 | 8 | 0 | 0 | 1 |
| SCI Frames (8 payload bits)(Figure 26-16) | | | | | | | | |
| 0 | 0 | 0 | 0 | 1 | 8 | 0 | 0 | 1 |
| 0 | 0 | 0 | 1 | 1 | 7 | 1 | 0 | 1 |
| 0 | 0 | 1 | 0 | 1 | 7 | 0 | 1 | 1 |
| SCI Frames (9 payload bits) (Figure 26-17) | | | | | | | | |
| 0 | 1 | 0 | 0 | 1 | 9 | 0 | 0 | 1 |
| 0 | 1 | 0 | 1 | 1 | 8 | 1 | 0 | 1 |
| 0 | 1 | 1 | 0 | 1 | 8 | 0 | 1 | 1 |

¹ The address bit identifies the frame as an address character. See [Section 26.4.5.5, Multiprocessor Communication](#).

Table 26-19. Supported Data Frame Formats for RX only

| Control | | | | Frame Content | | | | |
|--|----------|----|------|---------------|----------------|--------------|-------------|-----------|
| eSCI_CR3 | eSCI_CR1 | | | Start Bits | Payload Bits | | | Stop Bits |
| M2 | M | PE | WAKE | | Character Bits | Address Bits | Parity Bits | |
| SCI Frames (2 stop bits) (see Figure 26-18) | | | | | | | | |
| 1 | 0 | 1 | 0 | 1 | 8 | 0 | 1 | 2 |
| 1 | 1 | 1 | 0 | 1 | 12 | 0 | 1 | 2 |

The structure of the LIN frames in normal polarity is shown in [Figure 26-15](#).



Figure 26-15. LIN Byte Field Format

The structures of the supported SCI frame formats with 8 payload bits are shown in [Figure 26-16](#).

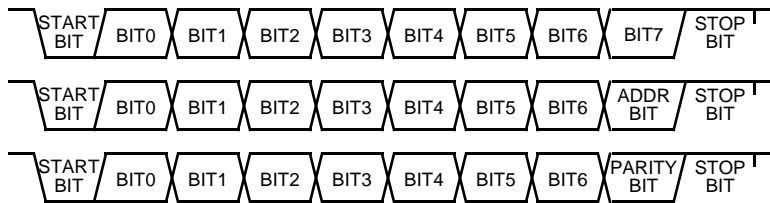

Figure 26-16. SCI Frame Formats (8 payload bits)

The structures of the supported SCI frame formats with 9 payload bits are shown in [Figure 26-17](#).

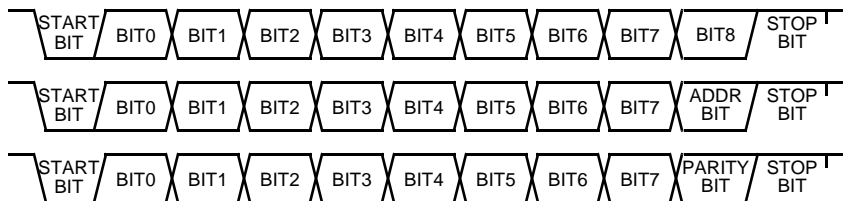

Figure 26-17. SCI Frame Formats (9 payload bits)

The structures of the supported SCI frame formats with 2 stop bits in normal polarity are shown in [Figure 26-18](#). This frame format is supported for reception only.

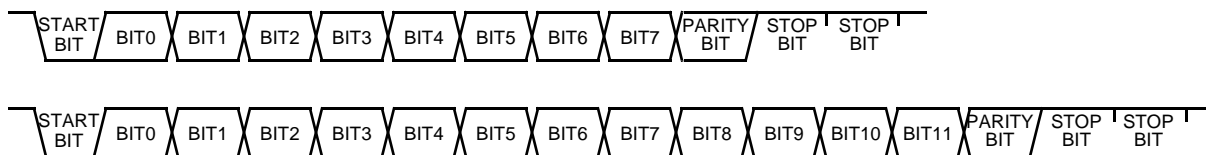

Figure 26-18. SCI Frame Formats (2 stop bits)

26.4.2.1.1 Inverted Data Frame Formats

The structures of the supported data frame formats in inverted polarity are shown in [Figure 26-19](#). These frame types are supported for reception only. The polarity of the RXD pin is controlled by the RXPOL bit in the [Control Register 2 \(eSCI_CR2\)](#).

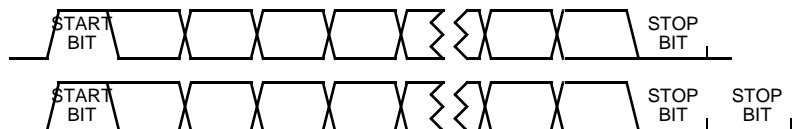

Figure 26-19. Inverted SCI Frame Formats

26.4.2.2 Break Character Formats

The supported break character formats are specified in [Table 26-20](#).

Table 26-20. Supported Break Character Formats

| Control ¹ | | | Break Character Content | | |
|---|----------|----------|-------------------------|----------------|--------------|
| eSCI_CR3 | eSCI_CR1 | eSCI_CR2 | Start Bit | Character Bits | Delemit Bits |
| M2 | M | BRCL | | | |
| LIN Break Symbol (see Figure 26-20) | | | | | |
| 0 | 0 | 0 | 1 | 9 | 1 |
| 0 | 0 | 1 | 1 | 12 | 1 |
| SCI Break Character (see Figure 26-21) | | | | | |
| 0 | 0 | 0 | 1 | 9 | 0 |
| 0 | 0 | 1 | 1 | 12 | 0 |
| 0 | 1 | 0 | 1 | 10 | 0 |
| 0 | 1 | 1 | 1 | 13 | 0 |

¹ All codings which are not listed are reserved and must not be used.

The structure and content of the LIN break symbols is shown in [Figure 26-20](#).

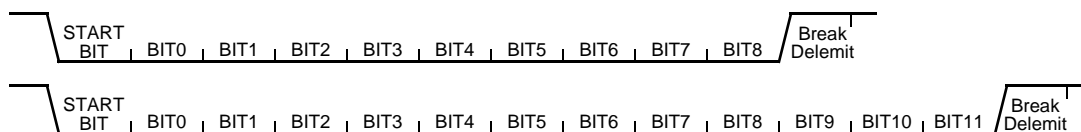

Figure 26-20. LIN Break Symbol Format

The structure and content of the SCI break characters is shown in [Figure 26-21](#).

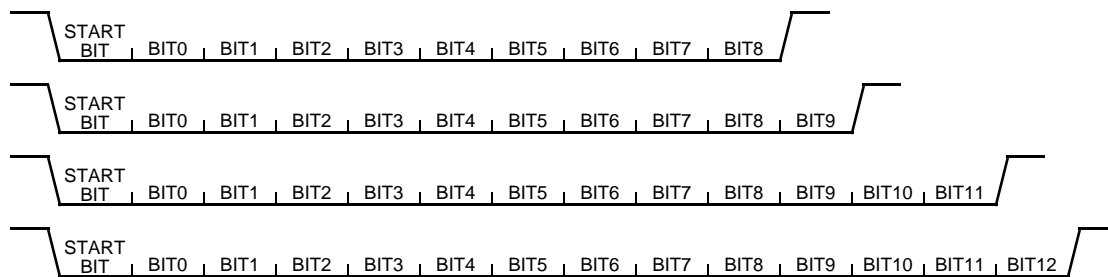

Figure 26-21. SCI Break Character Formats

26.4.2.3 Idle Character Formats

An idle character is a sequence of bits with the value 1. The supported idle character formats are specified in [Table 26-21](#). The preamble has the same structure and content as an idle character.

Table 26-21. Supported Idle Character Formats

| Control | | Idle Character Length |
|---|-------------|-----------------------|
| eSCI_CR3[M2] | eSCI_CR1[M] | |
| Idle Characters (see Figure 26-22) | | |
| 0 | 0 | 10 |
| 0 | 1 | 11 |
| 1 | 0 | 12 |
| 1 | 1 | 16 |

The structure and content of the idle characters is shown in [Figure 26-22](#).

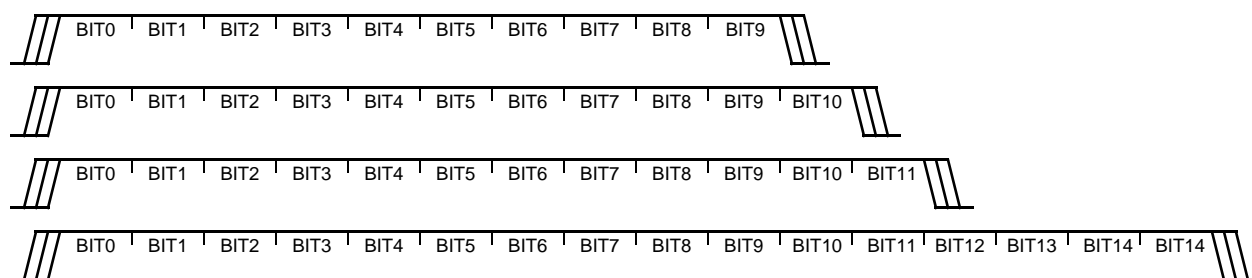

Figure 26-22. Idle Character Formats

26.4.3 Baud Rate and Clock Generation

A 13-bit modulus counter in the baud rate generator derives the baud rate for both the receiver and the transmitter. The value written to the SBR field in the [Baud Rate Register \(eSCI_BRR\)](#) determines the module clock divisor. The baud rate clock is synchronized with the bus clock and drives the receiver. The baud rate clock divided by 16 drives the transmitter. The receiver has an acquisition rate of 16 samples per bit time.

The baud rate generator is enabled when the TE bit or RE bit in the [Control Register 1 \(eSCI_CR1\)](#) is set to 1 for the first time. The baud rate generator is disabled when SBR = 0.

Baud rate generation is subject to one source of error:

- Integer division of the module clock may not give the exact required target baud rate.

[Figure 26-22](#) lists some examples of achieving target baud rates with a module clock frequency of MCLK = 10.2 MHz.

Table 26-22. Baud Rates Error Example (MCLK = 10.2 MHz)

| eSCI_BRR[SBR] | RCLK (Hz) | TCLK (Hz) | Target Baud Rate | Error (%) |
|---------------|-----------|-----------|------------------|-----------|
| 17 | 600,000.0 | 37,500.0 | 38,400 | 2.3 |
| 33 | 309,090.9 | 19,318.2 | 19,200 | .62 |
| 66 | 154,545.5 | 9659.1 | 9600 | .62 |
| 133 | 76,691.7 | 4793.2 | 4800 | .14 |
| 266 | 38,345.9 | 2396.6 | 2400 | .14 |
| 531 | 19,209.0 | 1200.6 | 1200 | .11 |
| 1062 | 9604.5 | 600.3 | 600 | .05 |
| 2125 | 4800.0 | 300.0 | 300 | .00 |
| 4250 | 2400.0 | 150.0 | 150 | .00 |
| 5795 | 1760.1 | 110.0 | 110 | .00 |

26.4.3.1 Module Clock

The module clock MCLK is derived from the system bus clock. It has the same phase and frequency.

26.4.3.2 Transmitter Clock

The transmitter clock TCLK is used to drive the data to the serial bus via the TXD pin. It is derived from the system bus clock by the baud rate generator. The baud rate generator is controlled by the value of the SBR field in the [Baud Rate Register \(eSCI_BRR\)](#). The frequency of the transmitter clock is determined by [Equation 26-1](#) and defines the length of the transmitted bits, which is denoted as the *bit time*.

$$f_{\text{TCLK}} = \frac{f_{\text{MCLK}}}{16 \cdot \text{SBR}} \quad \text{Eqn. 26-1}$$

26.4.3.3 Receiver Clock

The receiver clock RCLK is used to sample the data received on the RXD or TXD pin. It is derived from the system bus clock by the baud rate generator. The baud rate generator is controlled by the value of the SBR field in the [Baud Rate Register \(eSCI_BRR\)](#). The frequency of the receiver sample clock is determined by [Equation 26-2](#).

$$f_{\text{RT}} = \frac{f_{\text{MCLK}}}{\text{SBR}} \quad \text{Eqn. 26-2}$$

The frequency of the receiver clock is 16 times the frequency of the transmitter clock, this each bit is sampled with 16 samples. Each of the 16 samples of a bit has a sample number assigned, which is defined by the receiver sample counter RSC. The n-th sample is denoted by RSn. The receiver sample counter RSC is updated with each rising edge of the receiver clock RCLK.

26.4.4 Baud Rate Tolerance

A transmitting device may be operating at a baud rate below or above the receiver baud rate. Accumulated bit time misalignment can cause one of the three stop bit data samples RS8, RS9, and RS10 to fall outside the actual stop bit. A noise error will occur if the stop bit sample RS8, RS9, and RS10 samples are not all the same logical value 1. A framing error will occur if the receiver clock is misaligned in such a way that the majority of the RS8, RS9, and RS10 stop bit samples are a logic zero.

26.4.4.1 Faster Receiver Tolerance

In this case the receiver has a higher baud rate than the transmitter, thus the stop bit sampling starts already in the last transmitted payload bit. To ensure the correct, noise and framing error free reception of the stop bit, the samples RS8, RS9, and RS10 must be located in the transmitted stop bit as shown in [Figure 26-23](#).

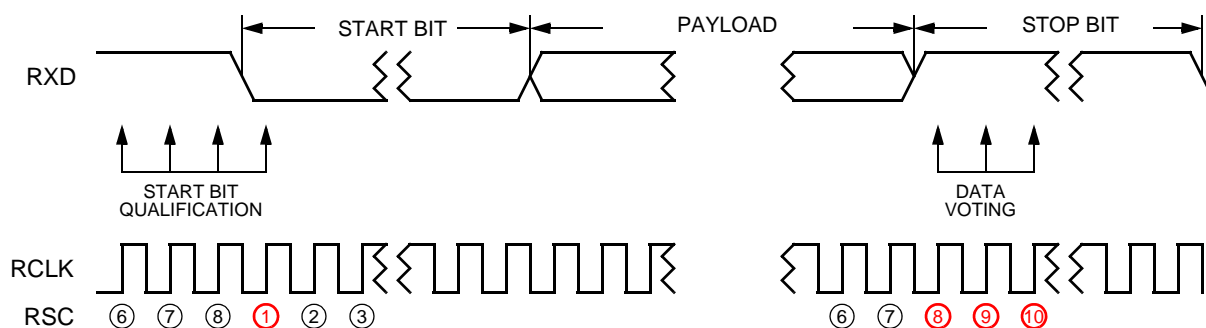

Figure 26-23. Faster Receiver

The maximum tolerance that ensures error free reception can be calculated with the assumption, that RS7 is sampled during the last transmitted payload bit and RS8 is sampled in the stop bit.

For an frame with n payload bits the transmitter starts the transmission of the stop bit

$$t_{X_{STOP}} = (n + 1) \cdot 16 \cdot RT_{TR} \tag{Eqn. 26-3}$$

after the start of the transmission of the start bit.

For an frame with n payload bits the receiver samples the RS8 sample of the stop bit

$$t_{X_{STOP}} = (n + 1) \cdot 16 \cdot RT_{RE} + 7 \cdot RT_{RE} \tag{Eqn. 26-4}$$

after the successful qualification of the start bit.

To ensure error free reception of the stop bit, the transmitter must start the transmission of the stop bit before the receiver samples RSC8.

$$t_{X_{STOP}} < t_{X_{STOP}} \tag{Eqn. 26-5}$$

The maximum percent difference between the receiver baud rate and the transmitter baud rate is:

$$\Delta\text{baudrate} \leq \left(\frac{r_{X_STOP} - t_{X_STOP}}{r_{X_STOP}} \right) \times 100 \quad \text{Eqn. 26-6}$$

The maximum percent differences for the supported frames is given in [Table 26-23](#)

Table 26-23. Faster Receiver Maximum Tolerance

| payload bits | max baudrate difference | t _{XSTOP} | r _{XSTOP} |
|--------------|-------------------------|--------------------|--------------------|
| 8 | 4.63% | 144 | 151 |
| 9 | 4.19% | 160 | 167 |
| 13 | 3.03% | 224 | 231 |

26.4.4.2 Slower Receiver Tolerance

In this case the receiver has a slower baud rate than the transmitter, thus the stop bit sampling is still running while the next start bit is already transmitted. To ensure the correct, noise and framing error free reception of the stop bit, the samples RS8, RS9, and RS10 must be located in the transmitted stop bit as shown in [Figure 26-24](#).

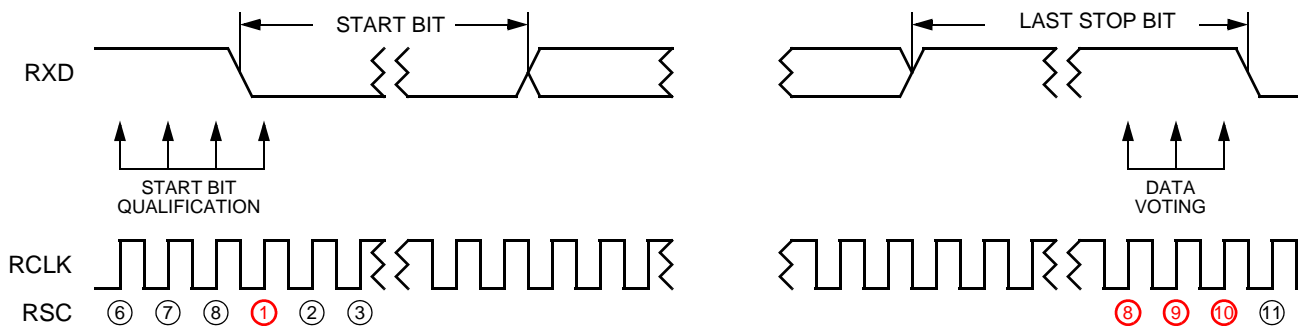

Figure 26-24. Slower Receiver

The maximum tolerance that ensures error free reception can be calculated with the assumption, that RS11 is sampled in the transmitted start bit and RS10 is sampled in the last stop bit.

For an frame with n payload bits and s stop bits, the transmitter starts the transmission of the next start bit

$$t_{X_START} = (n + s + 1) \cdot 16 \cdot RT_{TR} \quad \text{Eqn. 26-7}$$

after the start of the transmission of the previous start bit.

For an frame with n payload bits and s stop bits, the receiver samples the RS10 sample of the last stop bit

$$r_{X_STOP} = (n + s) \cdot 16 \cdot RT_{RE} + 9 \cdot RT_{RE} \quad \text{Eqn. 26-8}$$

after the successful qualification of the start bit.

To ensure error free reception of the last stop bit, the transmitter must start the transmission of the start bit after the receiver samples RS10.

$$r_{X_STOP} < t_{X_START} \quad \text{Eqn. 26-9}$$

The maximum percent difference between the receiver baud rate and the transmitter baud rate is:

$$\Delta\text{baudrate} \leq \left(\frac{t_{X_START} - r_{X_STOP}}{t_{X_START}} \right) \times 100 \quad \text{Eqn. 26-10}$$

The maximum percent differences for the supported frames is given in [Table 26-24](#)

Table 26-24. Slower Receiver Maximum Tolerance

| payload bits | stop bits | max baudrate difference | r _{XSTOP} | t _{XSTART} |
|--------------|-----------|-------------------------|--------------------|---------------------|
| 8 | 1 | 4.37% | 153 | 160 |
| 9 | 1 | 3.97% | 169 | 176 |
| 9 | 2 | 3.57% | 185 | 196 |
| 13 | 2 | 2.73% | 249 | 256 |

26.4.5 SCI Mode

26.4.5.1 SCI Mode Configuration

The application must configure the following bits and fields in order to achieve correct SCI operation.

- enable *SCI* Mode
 - [LIN Control Register 1 \(eSCI_LCR1\)\[LIN\]](#) := 0
- select *baud rate*
 - [Baud Rate Register \(eSCI_BRR\)\[SBR\]](#)
- select *receiver input* mode
 - [Control Register 1 \(eSCI_CR1\)\[LOOPS\]](#)
 - [Control Register 1 \(eSCI_CR1\)\[RSRC\]](#)
- select *frame format*
 - [Control Register 1 \(eSCI_CR1\)\[M\]](#)
 - [Control Register 1 \(eSCI_CR1\)\[PE\]](#)
 - [Control Register 1 \(eSCI_CR1\)\[WAKE\]](#)
 - [Control Register 3 \(eSCI_CR3\)\[M2\]](#)
- select *parity type*
 - [Control Register 1 \(eSCI_CR1\)\[PT\]](#)

26.4.5.2 Transmitter

The transmitter supports the transmission of all frame types defined in [Table 26-18](#), of all break characters defined in [Table 26-20](#), and of all idle characters defined in [Table 26-21](#).

26.4.5.2.1 Transmitter States and Transitions

The transmitter has four basic states which are shown and described in [Table 26-25](#). The state transitions that can triggered by the application commands are shown in [Table 26-26](#). The state transitions that can

triggered by the module are shown in [Table 26-27](#). The state diagram of the transmitter is shown in [Figure 26-25](#).

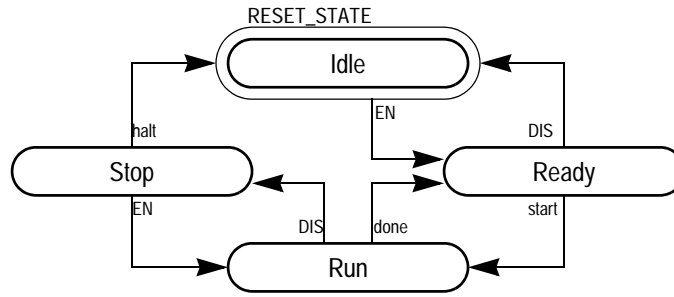

Figure 26-25. Transmitter State Diagram

The current state of the transmitter can be determined by the TE control bit in the [Control Register 1 \(eSCI_CR1\)](#) and the TACT status bit in [Interrupt Flag and Status Register 1 \(eSCI_IFSR1\)](#).

Table 26-25. Transmitter States

| State | Indication | | Description |
|-------|--------------|------------------|--|
| | eSCI_CR1[TE] | eSCI_IFSR1[TACT] | |
| Idle | 0 | 0 | Transmitter is <i>disabled</i> and <i>no</i> transmission is running |
| Ready | 1 | 0 | Transmitter is <i>enabled</i> and <i>no</i> transmission is running |
| Run | 1 | 1 | Transmitter is <i>enabled</i> and transmission is running |
| Stop | 0 | 1 | Transmitter is <i>disabled</i> and transmission is running |

The application triggers a transition described in [Table 26-26](#) when it issues a command by writing to the TE bit in the [Control Register 1 \(eSCI_CR1\)](#). The transition is triggered only if the conditions are fulfilled. As a result of the transition the state of the transmitter is changed as shown in [Figure 26-25](#) and the action given in [Table 26-26](#) is executed.

Table 26-26. Transmitter Application Transitions

| Transition | Command | Precondition | Action | Description |
|------------|-----------------|----------------|---------|---|
| EN | eSCI_CR1[TE]:=1 | eSCI_CR1[TE]=0 | iPRE:=1 | Transmitter is <i>enabled</i> by application command. |
| DIS | eSCI_CR1[TE]:=0 | eSCI_CR1[TE]=1 | | Transmitter is <i>disabled</i> by application command |

The module transition shown in [Table 26-27](#) are triggered when the described condition or event occurs. The send break bit SBK in the [Control Register 1 \(eSCI_CR1\)](#) is check for the start condition. The internal commit bit iCMT, the transmitter active bit TACT in the [Interrupt Flag and Status Register 1 \(eSCI_IFSR1\)](#), the TDRE, and the TC flag in the [Interrupt Flag and Status Register 1 \(eSCI_IFSR1\)](#) are changed as a action result of the transition.

Table 26-27. Transmitter Module Transitions

| Transition | Condition | Action | Description |
|------------|---|--------------------------------------|---|
| start | (State=Ready) and (SBK=1 or iPRE=1 or iCMT=1) | TACT:=1 | Start of transmission of data frame or special character when data are available or character transmission request is pending. |
| done | State=Run and last stop bit transmitted | TACT:=0 TC:= (SBK & iPRE & TC) | Finished transmission of data frame or special character and transmitter still enabled. Transmission is complete if no transmit request is pending. |
| halt | State=Stop and last stop bit transmitted | TACT:=0 TC:=1 iCMT:=0 | Finished transmission of data frame or special character and transmitter was disabled. |

26.4.5.2.2 Frame and Character Transmission

The transmitter starts the transmission of a data frame or special character when the condition for the *start* transition as described in [Table 26-27](#) is fulfilled. There are three source for data or character transmission. The priority among these source are specified in [Table 26-28](#). All three sources can be available at one point in time.

Table 26-28. Transmit Source Priority

| Priority | Indication | Transmission Source |
|-------------|-----------------|--|
| (highest) 0 | eSCI_CR1[SBK]=1 | Break character. |
| 1 | iPRE=1 | Preamble. |
| (lowest) 2 | iCMT=1 | SCI Data Register (ESCI_DR) frame. |

26.4.5.2.3 CPU Controlled SCI Data Frame Transmission

The transmission of a data frame is started when the transmitter is in its Ready state and only the commit bit iCMT is set.

As the first step, the content of the [SCI Data Register \(ESCI_DR\)](#) is transferred into the internal transmitter shift register. When this transfer is finished, the internal commit bit iCMT is cleared and the transmit data register empty flag TDRE in the [Interrupt Flag and Status Register 1 \(eSCI_IFSR1\)](#) is set. If the transmit interrupt enable bit TIE in the [Control Register 1 \(eSCI_CR1\)](#) is also set, the TDRE flag generates a transmitter interrupt request.

The transmitter shift register then shifts a frame out through the TXD output signal, which is prefaced with a start bit and appended with the parity bit, if configured, and the configured number of stop bits.

When the last stop bit has been transmitted and the application has not disabled the transmitter, the transmitter returns to the Ready state via the *done* transition. If no frame or character transmit request is pending, the transfer complete flag TC in the [Interrupt Flag and Status Register 1 \(eSCI_IFSR1\)](#) is set.

If the application has disabled the transmitter while the frame is transmitted and stop bit has been transmitted, the transmitter goes into the Idle state via the *halt* transition. The transfer complete flag TC in the [Interrupt Flag and Status Register 1 \(eSCI_IFSR1\)](#) is set and the internal commit bit iCMT is cleared.

26.4.5.2.4 DMA Controlled SCI Data Frame Transmission

In this mode, the eSCI module handles the generation of Data Frames internally.

When new data required for transmission, the module generates the transmit DMA request and the DMA controller delivers the required data via write accesses to [SCI Data Register \(ESCI_DR\)](#). The write access to the low byte of [SCI Data Register \(ESCI_DR\)](#) triggers the transmission of the data. The write access to the high byte of [SCI Data Register \(ESCI_DR\)](#) triggers no internal operation.

The application request the eSCI module to enter this mode by setting the TXDMA bit in the [Control Register 2 \(eSCI_CR2\)](#). From this point in time, the module start the generation of DMA requests and frame transmission. Before entering this mode, the application should perform the following actions:

1. Configure the module for SCI mode.
2. Enable the transmitter by setting TE in [Control Register 1 \(eSCI_CR1\)](#) to 1.
3. Setup the DMA controller channel and provide frame data in system memory

A block diagram which presents an overview of the DMA Controlled Date Frame Transmission is shown in [Figure 26-26](#).

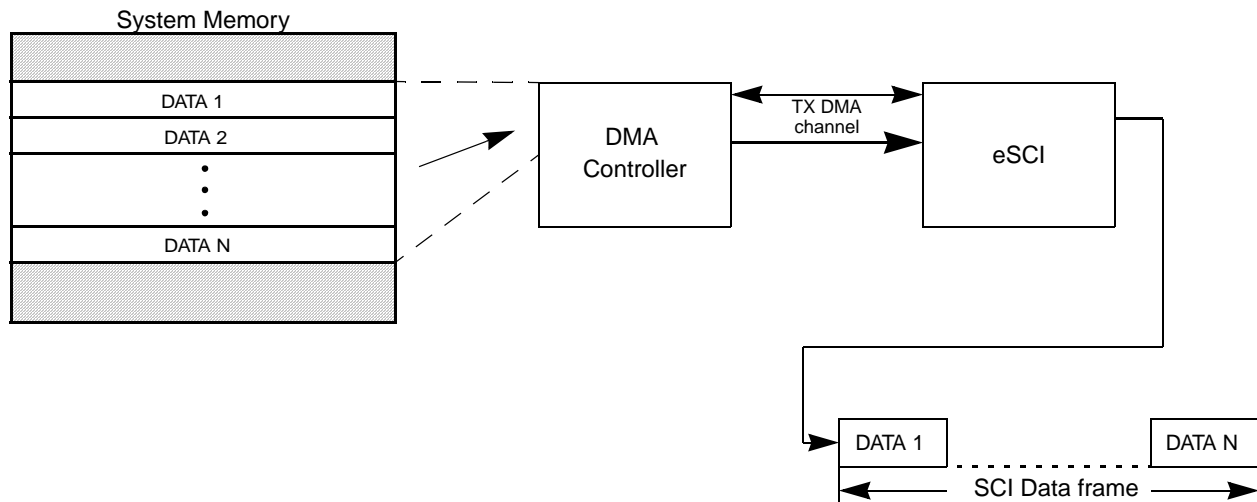

Figure 26-26. DMA Controlled SCI Data Frame generation

26.4.5.2.5 Parity Generation

The eSCI module generates the parity bit in transmitted data frame when the parity enable bit PE in the [Control Register 1 \(eSCI_CR1\)](#) is set. The parity type bit PT in the [Control Register 1 \(eSCI_CR1\)](#) defines whether the odd or even parity is generated.

26.4.5.2.6 Preamble Transmission

The transmission of a preamble is started when the transmitter is in Ready state, the internal iPRE bit, which is not visible to the application, is set, and the SBK in the [Control Register 1 \(eSCI_CR1\)](#) is clear.

After the transmission of the stop bit and if the application has not disabled the transmitter, the transmitter returns to the Ready state via the *done* transition. If no frame or character transmit request is pending, the transfer complete flag TC in the [Interrupt Flag and Status Register 1 \(eSCI_IFSR1\)](#) is set.

If the application has disabled the transmitter while the preamble is transmitted and if the stop bit has been transmitted, the transmitter goes into the Idle state via the *halt* transition. The transfer complete flag TC in the [Interrupt Flag and Status Register 1 \(eSCI_IFSR1\)](#) is set and the internal commit bit iCMT is cleared.

26.4.5.2.7 Break Character Transmission

The transmission of a break character is started when the transmitter is in Ready state and the send break character bit SBK in the [Control Register 1 \(eSCI_CR1\)](#) is set. After the transmission of the break character and if the application has not disabled the transmitter, the transmitter returns to the Ready state via the *done* transition and restarts the transmission. As long as SBK bit remains set, the transmitter continues to send break characters.

When the application has cleared the SBK bit or has disabled the transmitter, the transmitter continues to transmit the current break character and after it has finished the transmission of this break character it transmits a stop bit. The stop bit at the end of a break character sequence guarantees the recognition of the start bit of the next data frame.

After the transmission of the stop bit and if the application has not disabled the transmitter, the transmitter returns to the Ready state via the *done* transition. If no frame or character transmit request is pending, the transfer complete flag TC in the [Interrupt Flag and Status Register 1 \(eSCI_IFSR1\)](#) is set.

If the application has disabled the transmitter while the break character is transmitted and if the stop bit has been transmitted, the transmitter goes into the Idle state via the *halt* transition. The transfer complete flag TC in the [Interrupt Flag and Status Register 1 \(eSCI_IFSR1\)](#) is set and the internal commit bit iCMT is cleared.

26.4.5.3 Receiver

The receiver supports the reception of all data frame types defined in [Table 26-18](#) and [Table 26-19](#), of all break character defined in [Table 26-20](#), and of all idle characters defined in [Table 26-21](#).

26.4.5.3.1 Receiver States and Transitions

The receiver has four basic states which are shown and described in [Table 26-26](#). The state transitions that can triggered by the application commands are shown in [Table 26-26](#). The state transitions that can triggered by the module are shown in [Table 26-27](#). The state diagram of the transmitter is shown in [Figure 26-25](#).

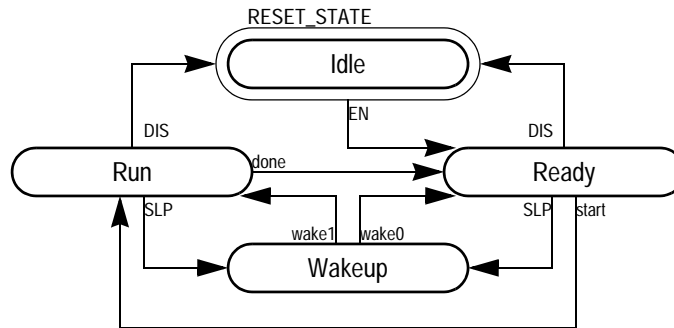

Figure 26-27. Receiver State Diagram

The current state of the receiver can be determined by the RE and RWU bit in the [Control Register 1 \(eSCI_CR1\)](#) and the RACT status bit in [Interrupt Flag and Status Register 1 \(eSCI_IFSR1\)](#).

Table 26-29. Receiver States

| State | Indication | | | Description |
|--------|------------|------|-----|--|
| | RE | RACT | RWU | |
| Idle | 0 | 0 | 0 | Receiver is <i>disabled</i> and <i>no</i> reception is running |
| Ready | 1 | 0 | 0 | Receiver is <i>enabled</i> and <i>no</i> reception is running |
| Run | 1 | 1 | 0 | Receiver is <i>enabled</i> and reception is running |
| Wakeup | 1 | - | 1 | Receiver is in wakeup mode |

The application triggers a transition described in [Table 26-30](#) when it issues a command by writing to the RE bit in the [Control Register 1 \(eSCI_CR1\)](#). The transition is triggered only if the conditions are fulfilled. As a result of the transition the state of the receiver is changed as shown in [Figure 26-27](#) and the action given in [Table 26-30](#) is executed.

Table 26-30. Receiver Application Transition

| Transition | Command | Condition | Action | Description |
|------------|---------|-----------|--------|--|
| EN | RE:=1 | RE=0 | | Receiver is <i>enabled</i> by application command. |
| DIS | RE:=0 | RE=1 | | Receiver is <i>disabled</i> by application command |
| SLP | RWU:=1 | RE=1 | | Receiver is set into wakeup mode |

The module transition shown in [Table 26-31](#) are triggered when the described event occurs.

Table 26-31. Receiver Module Transition

| Transition | Condition | Action | Description |
|------------|--|---------|--|
| start | (State=Ready,Run) and (start bit received) | RACT:=1 | Start of reception of data frame or break character. |
| done | (State=Run) and (idle character received) | RACT:=0 | Idle Character received. |
| wake0 | (State=Wakeup) and (idle character received) | RWU:=0 | Wakeup Idle Character received. |
| wake1 | (State=Wakeup) and (address frame received) | RWU:=0 | Wakeup address frame received. |

26.4.5.3.2 Receiver Input Mode Selection

This section describes the three receiver input modes supported by the eSCI module. The modes are selected by the LOOPS and RSRC control bits in the [Control Register 1 \(eSCI_CR1\)](#).

26.4.5.3.3 Dual Wire Mode

In Dual Wire Mode, the eSCI uses the TXD pin for transmitting and the RXD pin for data receiving.

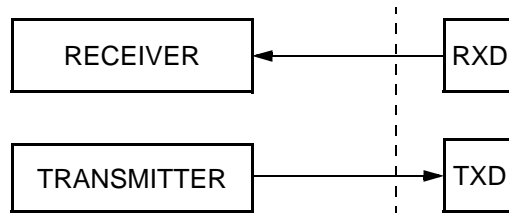

Figure 26-28. Dual Wire Mode

26.4.5.3.4 Single Wire Mode

In Single Wire Mode, the RXD pin is disconnected from the eSCI module and the TXD pin is used for both receiving and transmitting.

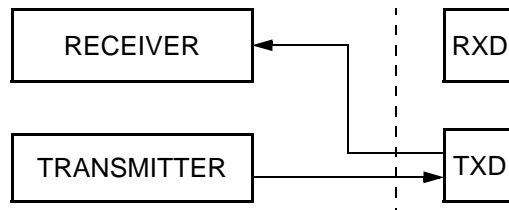

Figure 26-29. Single Wire Mode

The TXDIR bit (eSCI_CR2[1]) determines whether the TXD pin is going to be used as an input (TXDIR = 0) or an output (TXDIR = 1) in this mode of operation.

26.4.5.3.5 Loop Mode

In Loop Mode, the input of the receiver is driven by the output of the transmitter. The RXD pin is disconnected from the eSCI module.

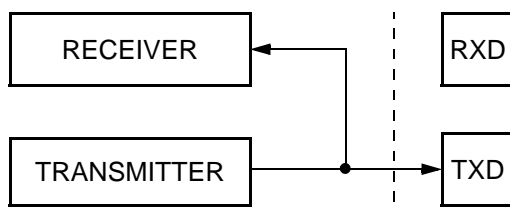

Figure 26-30. Loop Mode

26.4.5.3.6 Frame and Character Reception

The receiver is started when it is in Ready or Wakeup state and on the selected receiver input (see [Section 26.4.5.3.2, Receiver Input Mode Selection](#)) an active signal is sampled. The receiver enters the Run or Wakeup state. The received bits are recovered by the bit sampling described in [Section 26.4.5.3.13, Bit Sampling](#). During the reception, the received bits are shifted into the internal shift register.

26.4.5.3.7 Break Character Detection

The receiver does not provide any means to detect the reception of a break character. Instead, break characters are processed as data frames. Due to the received 0 at the stop bit location, the reception of a break character causes at least a framing error. The error reporting is performed as described in [Section 26.4.5.4, Reception Error Reporting](#).

26.4.5.3.8 Idle Character Detection

The start point of the idle character detection is controlled by the idle line type bit ILT in the [Control Register 1 \(eSCI_CR1\)](#).

If the ILT bit is 0, the idle character detection starts always immediately after the reception of a bit with the value 0. In this mode, a data frame with a payload section of all ones will be erroneously detected as an idle character.

If the ILT bit is 1, the idle character detection starts after the reception of the last stop bit.

26.4.5.3.9 CPU Controlled SCI Data Frame Reception

This section describes the reception process when the receiver is in the Run state.

When the required number of frame bits have been received, the payload bits of the received frame are transferred into [SCI Data Register \(ESCI_DR\)](#) if the RDRF flag is 0. The receive data register full flag RDRF in [Interrupt Flag and Status Register 1 \(eSCI_IFSR1\)](#) is set. If the receive interrupt enable bit RIE in the [Interrupt Flag and Status Register 1 \(eSCI_IFSR1\)](#) is set, the RDRF interrupt request is generated.

If an idle character has been detected, the IDLE flag in the [Interrupt Flag and Status Register 1 \(eSCI_IFSR1\)](#) is set. If the idle line interrupt enable bit ILIE in the [Control Register 1 \(eSCI_CR1\)](#) is set, the IDLE interrupt request is generated.

If any of the receiver errors described in [Section 26.4.5.4, Reception Error Reporting](#), have been occurred, that corresponding flags will be set.

If the application disabled the receiver by clearing the receiver enable bit RE in the [Interrupt Flag and Status Register 1 \(eSCI_IFSR1\)](#) the current frame is discarded and no flags will be updated.

26.4.5.3.10 DMA Controlled SCI Data Frames Reception

In this mode, the eSCI module controls the reception of SCI Data frames automatically and utilizes the connected DMA channels. A block diagram which presents an overview of the DMA Controlled SCI Data Frame reception is shown in [Figure 26-31](#). The RX DMA channel is used to transfer the received frame data into the memory.

When new data was received, the module generates the receive DMA request and the DMA controller retrieves the provided data from the [SCI Data Register \(ESCI_DR\)](#). The read access from the low byte of the [SCI Data Register \(ESCI_DR\)](#) signals the end of the DMA cycle for the current data and triggers the reception of new data. The read access from the [SCI Data Register \(ESCI_DR\)](#) triggers no internal action.

The application request the eSCI module to enter this mode by setting the RXDMA bit in the [Control Register 2 \(eSCI_CR2\)](#). From this point in time, the module start the generation of DMA requests and frame transmission and reception. Before entering this mode, the application should perform the following actions:

1. Configure the module for SCI mode.
2. Enable the receiver by setting RE in [Control Register 1 \(eSCI_CR1\)](#) to 1.
3. Setup the DMA controller channel.

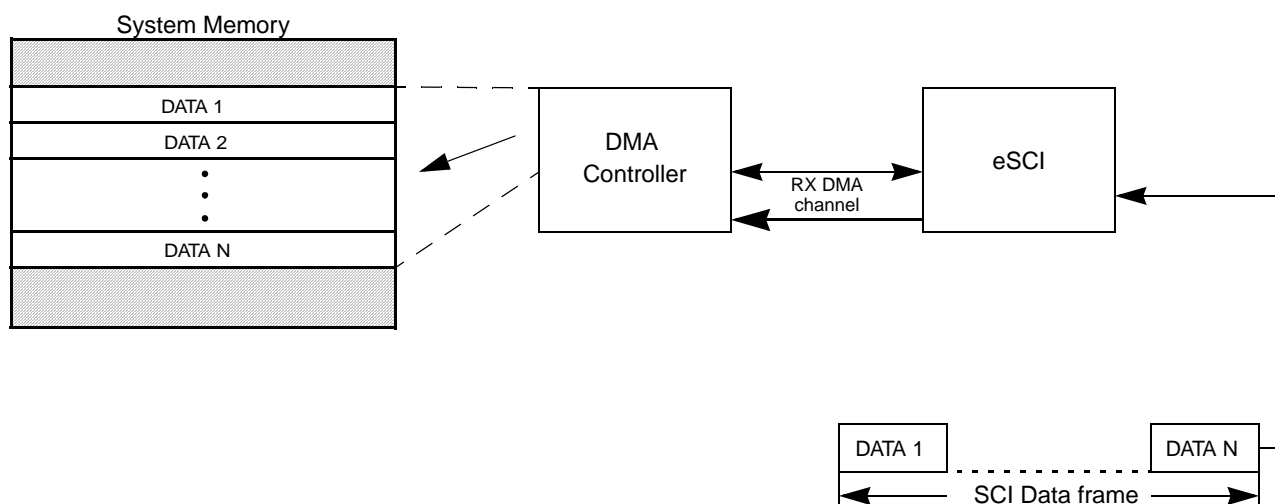

Figure 26-31. DMA Controlled SCI Data Frame Reception

26.4.5.3.11 Receiver Overrun

When the eSCI module has received a frame and attempts to transfer the payload data of the received frame into the [SCI Data Register \(ESCI_DR\)](#) but neither the application nor the DMA controller has read the [SCI Data Register \(ESCI_DR\)](#) since its last update, the overrun flag OR in the [Interrupt Flag and Status Register 1 \(eSCI_IFSR1\)](#) is set. The data contained in [SCI Data Register \(ESCI_DR\)](#) are not changed and the received data are lost.

26.4.5.3.12 Wake-up Frame Reception

This section describes the reception process when the receiver is in the Wakeup state.

When the required number of frame bits have been received, the payload bits of the received frame are transferred into [SCI Data Register \(ESCI_DR\)](#) if the RDRF flag is 0.

If the *address-mark* wake-up mode is selected and the received frame has the address bit set, the receive data register full flag RDRF in [Interrupt Flag and Status Register 1 \(eSCI_IFSR1\)](#) is set. If the receive interrupt enable bit RIE in the [Interrupt Flag and Status Register 1 \(eSCI_IFSR1\)](#) is set, the RDRF interrupt request is generated. The RWU bit is cleared, and the receiver enters the Run state via the wake1 transition.

If the *idle line* wake-up mode is selected and the receiver has detected an idle character, The RWU bit is cleared, and the receiver enters the Ready state via the wake0 transition.

If any of the receiver errors described in [Section 26.4.5.4, Reception Error Reporting](#), have been occurred, that corresponding flags will be set.

26.4.5.3.13 Bit Sampling

The receiver samples the selected receiver input (see [Section 26.4.5.3.2, Receiver Input Mode Selection](#)) with the receiver clock RCLK. The sampling for start bit detection is shown in [Figure 26-32](#), the sampling for data and stop bit reception is shown in [Figure 26-33](#). The samples indicated by dashed arrows are not used by the receiver. The received data bits are transferred into the internal shift register after the data strobing. If noise or framing errors were detected, this is flagged as described in [Section 26.4.5.4, Reception Error Reporting](#).

26.4.5.3.14 Bit Synchronization

To adjust for baud rate mismatch, a synchronization of the cyclic sample counter RSC is performed during start bit reception as described in [Section 26.4.5.3.15, Start Bit Sampling](#).

Additionally, the synchronization of the cyclic sample counter RSC can be configured to be performed during data bit reception as described in [Section 26.4.5.3.17, Data Bit Synchronization](#).

26.4.5.3.15 Start Bit Sampling

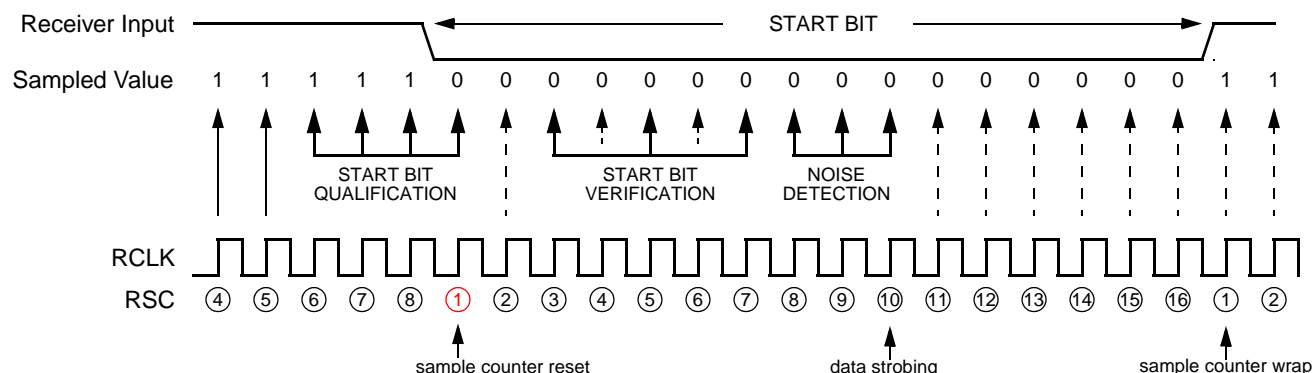

Figure 26-32. Start Bit Sampling and Strobing

Start Bit Qualification

To adjust for baud rate mismatch, the cyclic sample counter RSC is re-synchronized by reset after successful start bit qualification. A start bit is successfully qualified, if no reception is ongoing and three consecutive high samples are followed immediately by a low sample.

Start Bit Verification

After the successful start bit qualification the receiver starts to verify the start bit by a two out of three samples majority voting.

A start bit is verified if at least two out of the three sample RSC3, RSC5, and RSC5 are sampled low. Noise is detected when exactly one out of the three samples is high. The results of the start bit verification is summarized in [Table 26-32](#).

Table 26-32. Start Bit Verification Result

| [RS3, RS5, RS7] | Start Bit Verified | Noise Detected |
|-----------------|--------------------|----------------|
| 000 | Yes | No |
| 001 | Yes | Yes |
| 010 | Yes | Yes |
| 100 | Yes | Yes |
| 011 | No | No |
| 101 | No | No |
| 110 | No | No |
| 111 | No | No |

If the start bit verification was *not successful*, the receiver resumes the start bit qualification. If the start bit verification was *successful*, the receiver continues sampling to perform noise detection on the samples at RS8, RS9, and RS10. The results of the start bit noise detection is summarized in [Table 26-33](#).

Table 26-33. Start Bit Noise Detection

| [RS8, RS9, RS10] | Noise Detected |
|------------------|----------------|
| 000 | No |
| 001 | Yes |
| 010 | Yes |
| 100 | Yes |
| 011 | Yes |
| 101 | Yes |
| 110 | Yes |
| 111 | Yes |

26.4.5.3.16 Data Bit Sampling

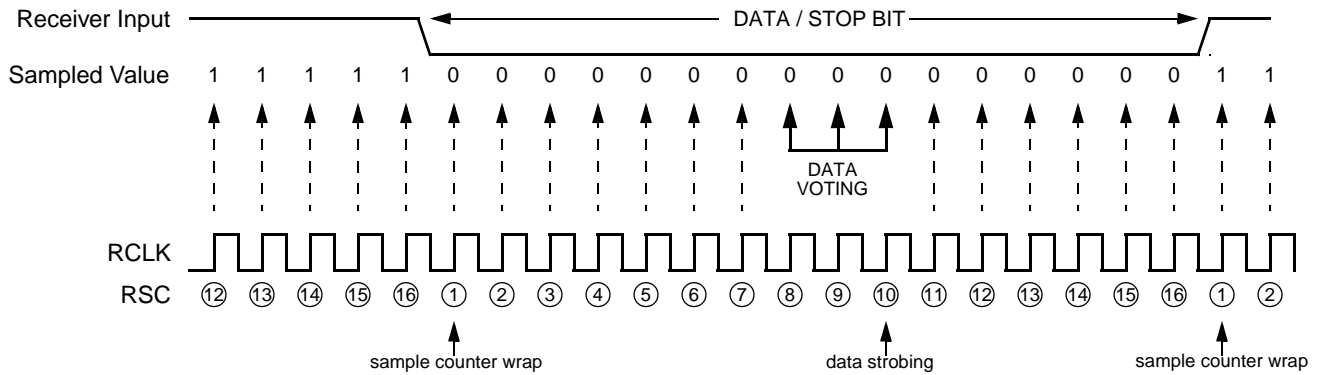

Figure 26-33. Data and Stop Bit Sampling and Strobing

To determine the value of a data bit and to detect noise, a two out of three majority voting is performed on the samples RS8, RS9, and RS10. [Table 26-34](#) summarizes the results of the data bit sample. The receiver detects the number of data bit according to the selected frame format.

Table 26-34. Data Bit Sampling

| [RS8, RS9, RS10] | Data Bit Value | Noise Detected |
|------------------|----------------|----------------|
| 000 | 0 | No |
| 001 | 0 | Yes |
| 010 | 0 | Yes |
| 100 | 0 | Yes |
| 011 | 1 | Yes |
| 101 | 1 | Yes |
| 110 | 1 | Yes |
| 111 | 1 | No |

26.4.5.3.17 Data Bit Synchronization

To adjust for baud rate mismatch during the reception of data bits, the cyclic sample counter RSC can be configured to be synchronized on falling edges during data bit reception. This kind of synchronization is performed only if the synchronization mode bit SYNPM in the [Control Register 3 \(eSCI_CR3\)](#) is 0.

Data Bit Synchronization (Right Shifted Edges)

This kind of sample counter synchronization happens if the transmitter is slower than the receiver. The reset behavior of the sample counter is shown in [Figure 26-34](#). The sample counter reset condition is:

1. The data bit N-1 is sampled as 1, and
2. the data bit N is sampled as 0, and
3. a falling edge consisting of three consecutive 1-samples and a following 0-sample is detected, and
4. the 0-sample of the falling edge is received at data bit N sample j, with $1 \leq j \leq 8$.

If the condition is fulfilled, the sample counter is reset 16 RCLK cycles after the 0 of the falling edge condition was received. The bit counter is not increased.

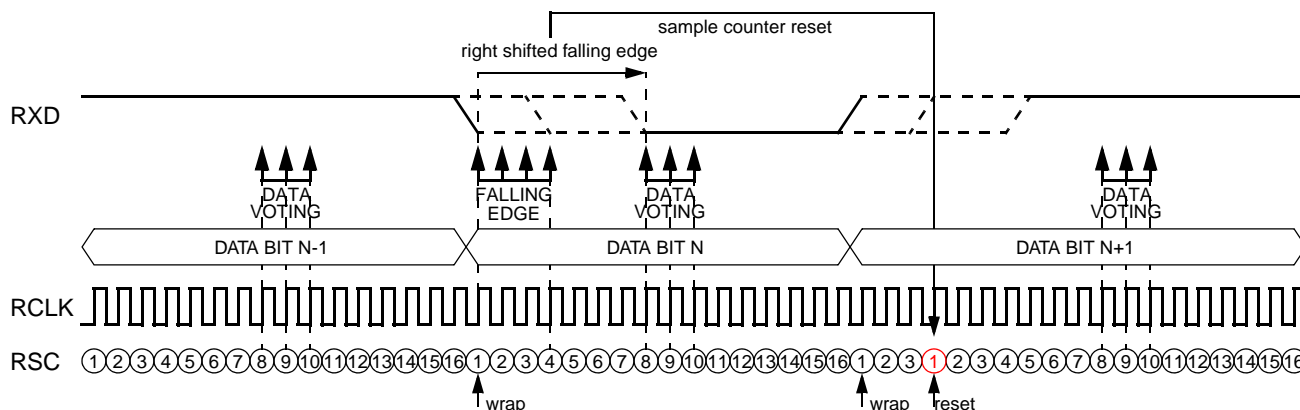

Figure 26-34. Data Bit Synchronization (Right Shifted Edges)

Data Bit Synchronization (Left Shifted Edges)

This kind of sample counter synchronization happens if the transmitter is faster than the receiver. The reset behavior of the sample counter is shown in [Figure 26-35](#). The sample counter reset condition is:

1. The data bit N-1 is sampled as 1, and
2. the data bit N is sampled as 0, and
3. a falling edge consisting of three consecutive 1-samples and a following 0-sample is detected, and
4. the 0-sample of the falling edge is received at data bit N sample j, with $11 \leq j \leq 16$.

If the condition is fulfilled, the sample counter is reset 16 RCLK cycles after the 0-sample of the falling edge condition was received. The bit counter is increased by 1.

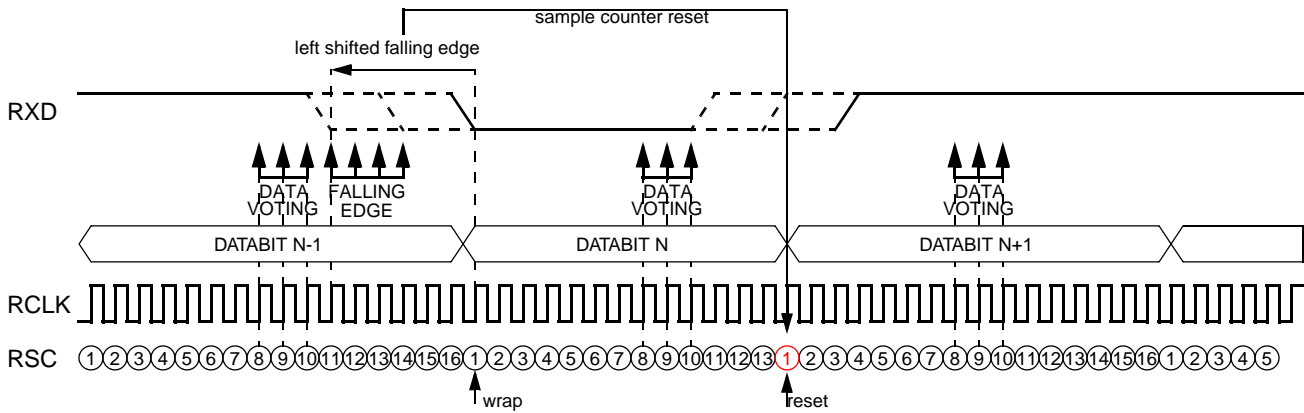
Figure 26-35. Data Bit Synchronization (Left Shifted Edges)

If the 0-sample of the falling edge condition is received at sample 9 or 10, no sample counter synchronization is performed.

26.4.5.3.18 Stop Bit Verification

The reception of a valid stop bit is verified if at least two out of the sample RS8, RS9, and RS10 are sampled high. If this is not that case, a framing error is detected. Noise is detected if not all of the samples are of the same value. The results of the stop bit verification are summarized in [Table 26-35](#).

Table 26-35. Stop Bit Verification

| [RS8, RS9, RS10] | Stop Bit Verified | Framing Error Detected | Noise Detected |
|------------------|-------------------|------------------------|----------------|
| 000 | No | Yes | No |
| 001 | No | Yes | Yes |
| 010 | No | Yes | Yes |
| 100 | No | Yes | Yes |
| 011 | Yes | No | Yes |
| 101 | Yes | No | Yes |
| 110 | Yes | No | Yes |
| 111 | Yes | No | No |

26.4.5.3.19 Parity Checking

The eSCI module calculates the parity of a received character and checks is versus the received parity bit in the received data frame when the parity enable bit PE in the [Control Register 1 \(eSCI_CR1\)](#) is set. The parity type bit PT in the [Control Register 1 \(eSCI_CR1\)](#) defines whether to check for odd or even parity is generated. If an parity error is detected, this is reported as described in [Section 26.4.5.4, Reception Error Reporting](#).

26.4.5.4 Reception Error Reporting

The receiver can detect four error types: parity errors, framing errors, noise errors, and the overrun error.

The receiver reports the errors detected during frame reception at the end of the reception of the last stop bit of a frame. For error reporting the receiver utilizes the OR, NF, FE, and PF flags in the [Interrupt Flag and Status Register 1 \(eSCI_IFSR1\)](#).

If the receiver has detected an overrun as described in [Section 26.4.5.3.11, Receiver Overrun](#), only the OR flag is set. All other error flags are not updated.

If the receiver has *not* detected an overrun and has detected noise as described in [Section 26.4.5.3.13, Bit Sampling](#), the NF flag is set.

If the receiver has *not* detected an overrun and has detected a framing error as described in [Section 26.4.5.3.13, Bit Sampling](#), the FE flag is set.

If the receiver has *not* detected an overrun and has detected a parity error as described in [Section 26.4.5.3.19, Parity Checking](#), the PF flag is set.

26.4.5.5 Multiprocessor Communication

The multiprocessor communication allows one processor to send blocks of frames to other processors on the same serial link. To avoid the received data interrupt for frames not intended for the processor, the eSCI receiver can be put into the Wakeup state. If the receiver is in the Wakeup state, the eSCI will still load the received data into the [SCI Data Register \(ESCI_DR\)](#), but will not set the RDRF flag and consequently not request the RDRF interrupt.

The receiver leaves the Wakeup state and clears the RWU bit in the [Control Register 1 \(eSCI_CR1\)](#) when the wakeup pattern configured by WAKE bit in [Control Register 1 \(eSCI_CR1\)](#) is received. The eSCI module supports two types of wakeup patterns, the idle-line wakeup pattern and the address-mark wakeup pattern.

26.4.5.5.1 Idle-Line Wakeup

The idle-line wakeup mode is selected when the WAKE bit in [Control Register 1 \(eSCI_CR1\)](#) is 0. In this mode, the receiver leaves the wakeup state, when an idle character is detected as described in [Section 26.4.5.3.8, Idle Character Detection](#). The next received frame is the address frame that contains address information which can be evaluated by the application. If the application decides not to receive the frame block, it can set the RWU bit in the [Control Register 1 \(eSCI_CR1\)](#) and return the receiver to the wakeup state.

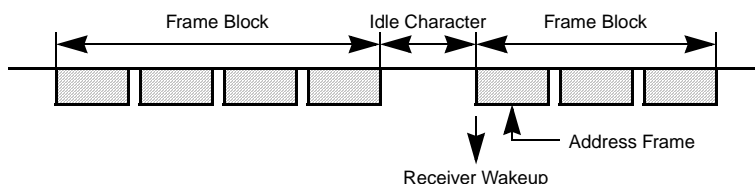

Figure 26-36. Idle-Line Wakeup Format

26.4.5.5.2 Address-Mark Wakeup

The address-mark wakeup mode is selected when the WAKE bit in **Control Register 1 (eSCI_CR1)** is 1. If the WAKE bit is set, the address bit is added to the frame format. In this mode, the receiver leaves the wakeup state, when a data frame with the address bit value of 1 was received. This frame is the address frame and contains address information which can be evaluated by the application. If the application decides not to receive the frame block, it can set the RWU bit in the **Control Register 1 (eSCI_CR1)** and return the receiver to the wakeup state. All data frames that belong to the frame block must have the address bit cleared.

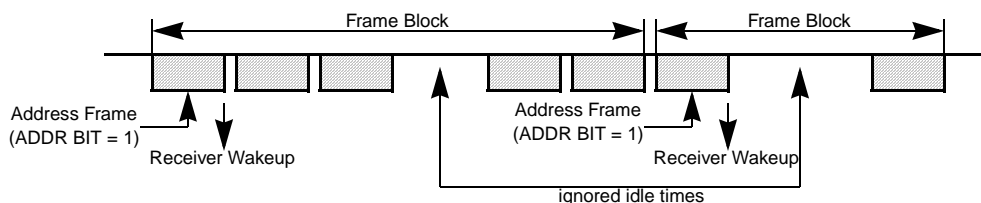

Figure 26-37. Address-Mark Wakeup Format

26.4.6 LIN Mode

The eSCI provides support for the LIN protocol. It can be used to automate most tasks of a LIN master. In conjunction with the DMA interface it is possible to transmit entire LIN frames and sequences of LIN frames as well as to receive data from LIN slaves without application intervention. There is no special support for LIN slave mode.

26.4.6.1 LIN Mode Configuration

The application must configure the following bits and fields in order to achieve correct LIN operation. The configuration of bits and fields not mentioned in this section depend on the connected LIN slaves and the current application.

- enable *LIN* Mode
 - **Control Register 1 (eSCI_LCR1)[LIN]**:= 1
- select *RXD* pin as receiver input
 - **Control Register 1 (eSCI_CR1)[LOOPS]**:= 0
 - **Control Register 1 (eSCI_CR1)[RSRC]**:= 0
- select *LIN byte fields* as used frame format
 - **Control Register 1 (eSCI_CR1)[M]**:= 0
 - **Control Register 1 (eSCI_CR1)[PE]**:= 0
 - **Control Register 1 (eSCI_CR1)[WAKE]**:= 0
 - **Control Register 3 (eSCI_CR3)[M2]**:= 0
- select *break character length* of 13 bit as required by LIN 2.0
 - **Control Register 2 (eSCI_CR2)[BRCL]**:= 1
- select transmission stop on *bit error* detection

- Control Register 2 (eSCI_CR2)[BESTP]:= 1
- select transmission DMA stop on *bit error* detection
 - Control Register 2 (eSCI_CR2)[BSTP]:= 1
- enable both *transmitter* and *receiver*
 - Control Register 1 (eSCI_CR1)[TE]:= 1
 - Control Register 1 (eSCI_CR1)[RE]:= 1

26.4.6.2 LIN frame formats

The term LIN frame refers to a sequence of LIN byte fields preceded by a break character, both are described in [Section 26.4.2, Frame Formats](#). The eSCI module allows to generate LIN frames for LIN slaves of LIN standards 1.3 and 2.0.

26.4.6.2.1 Standard LIN frames

A standard LIN frame, shown in [Figure 26-38](#) consists of a break character, a sync field, an ID field, zero or more data fields, and a checksum field. The data fields and the checksum field are generated by the LIN master for TX LIN frames and generated by the LIN slave for RX LIN frames. The header fields will always be generated by the LIN master.



Figure 26-38. Standard LIN frame format

26.4.6.2.2 CRC Enhanced LIN frames

The CRC Enhanced LIN frames shown in [Figure 26-39](#) contain two additional CRC byte fields. These fields are located between the last data field and the Checksum field. The value of the CRC is calculated on the same byte fields as the Checksum is calculated on. The polynomial used for the CRC calculation is defined by [LIN CRC Polynomial Register \(eSCI_LPR\)](#). The eSCI module generates the CRC fields for TX frames and checks the CRC fields for RX frames if the CRC bit in the [LIN Transmit Register \(eSCI_LTR\)](#) was written with a value of 1.



Figure 26-39. CRC Enhanced LIN frame format

The CRC Enhanced LIN frames are not part of the LIN standard.

26.4.6.3 LIN TX Frame generation

The eSCI module supports two modes of LIN TX Frame generation, the CPU controlled mode and the DMA controlled mode. In the CPU controlled mode, the application provides the required frame configuration and frame data by subsequent CPU write accesses to the [LIN Transmit Register \(eSCI_LTR\)](#). In the DMA controlled mode, the DMA controller provides the required frame configuration and frame data in response to DMA requests generated by the eSCI module.

26.4.6.3.1 CPU Controlled LIN TX Frame generation

In this mode, the application initiates the generation of an LIN TX Frame and provides the data to be transmitted by a sequence of subsequent CPU write accesses to the [LIN Transmit Register \(eSCI_LTR\)](#). When the eSCI module has processed the data written into [LIN Transmit Register \(eSCI_LTR\)](#), the TXRDY interrupt flag in the [Interrupt Flag and Status Register 2 \(eSCI_IFSR2\)](#) will be set.

The application should clear the TXRDY interrupt flag *before* writing data into the [LIN Transmit Register \(eSCI_LTR\)](#) because the eSCI module will set the TXRDY one clock cycle after the write access.

The first data written to the [LIN Transmit Register \(eSCI_LTR\)](#) provides the Identifier and Identifier Parity fields. The second data written defines the number of data bytes to be transmitted. The third data written defines the CRC and checksum generation. The TD bit has to set to 1 in order to invoke the LIN TX frame generation. The value of the TO field is ignored by the eSCI module for LIN TX frames.

After the third data was written the generation of a LIN TX frame is started. Firstly, a break field is transmitted, then the synch field and the protected identifier field.

All subsequent write accesses to the [LIN Transmit Register \(eSCI_LTR\)](#) provide data bytes to be transmitted via the LIN bus. A data byte field will be transmitted as soon as data are available. After the last data byte, defined by the value written to the LEN field, was send out, the configured CRC and checksum fields will be send out.

After the transmission of the checksum field of the LIN TX frame, the write access counter for the [LIN Transmit Register \(eSCI_LTR\)](#) is reset and the FRC interrupt flag in the [Interrupt Flag and Status Register 2 \(eSCI_IFSR2\)](#) is set.

26.4.6.3.2 DMA Controlled LIN TX Frame generation

In this mode, the eSCI module controls the generation of an LIN TX Frame. When new data required for transmission, the eSCI module generates the transmit DMA request and the DMA controller delivers the required data. The application request the eSCI module to enter this mode by setting the TXDMA bit in the [Control Register 2 \(eSCI_CR2\)](#). From this point in time, the module start the generation of DMA requests and initiates the frame transmission. Before entering this mode, the application should perform the following actions:

1. Configure the module for LIN mode.
2. Enable the transmitter by setting TE in [Control Register 1 \(eSCI_CR1\)](#) to 1.
3. Setup the DMA controller channel and provide frame data in system memory

A block diagram which presents an overview of the DMA Controlled LIN TX Frame is shown in [Figure 26-40](#). The content of the fields in the memory is the same as described in [LIN Transmit Register \(eSCI_LTR\) - LIN TX frame generation](#).

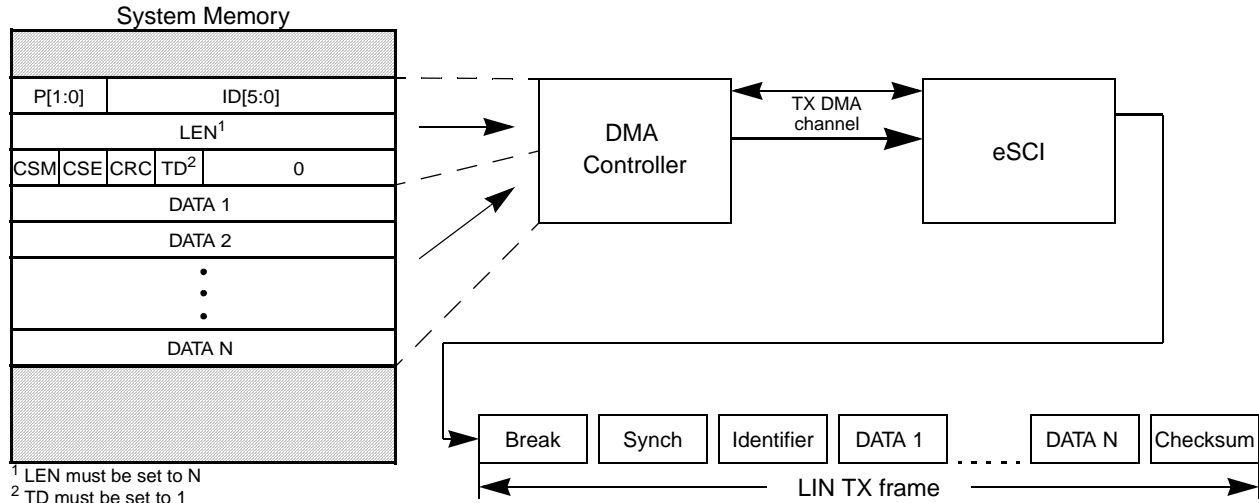

Figure 26-40. DMA Controlled LIN TX Frame generation

26.4.6.4 LIN RX frame generation

The eSCI module supports two modes of LIN RX Frame generation and reception, the CPU controlled mode and the DMA controlled mode. In the CPU controlled mode, the application provides the required data by subsequent CPU write accesses to the [LIN Transmit Register \(eSCI_LTR\)](#) and retrieves the received data by subsequent CPU read accesses to the [LIN Receive Register \(eSCI_LRR\)](#). In the DMA controlled mode, the DMA controller provides the required frame configuration data in response to DMA requests generated by the eSCI module and transfers the received frame data to the memory in response to DMA requests generated by the eSCI module.

26.4.6.4.1 CPU Controlled LIN RX Frames generation

In this mode, the application initiates the generation of an LIN RX Frame by a sequence of subsequent CPU write accesses to the [LIN Transmit Register \(eSCI_LTR\)](#). When the eSCI module has processed the data written into [LIN Transmit Register \(eSCI_LTR\)](#), the TXRDY interrupt flag in the [Interrupt Flag and Status Register 2 \(eSCI_IFSR2\)](#) will be set.

The application should clear the TXRDY interrupt flag *before* writing data into the [LIN Transmit Register \(eSCI_LTR\)](#) because the eSCI module will set the TXRDY one clock cycle after the write access.

The first data written to the [LIN Transmit Register \(eSCI_LTR\)](#) provides the Identifier and Identifier Parity fields. The second data written defines the number of data bytes requested from the LIN slave. The third data written defines the CRC and checksum generation. The TD bit has to set to 0 to invoke the RX frame generation. The TO field defines the upper part of the timeout value. The fourth byte written defines the lower part of the timeout value.

After the fourth byte was written the generation of a LIN RX frame is started. Firstly, a break field is transmitted, then the synch field and the protected identifier field. After the transmission of the protected identifier, the eSCI module starts to receive the frame data transmitted by the LIN slave. When the module has received a complete byte field, the received data are transferred into the [LIN Receive Register](#)

(eSCI_LRR) and the receive data ready flag RXRDY in the [Interrupt Flag and Status Register 2 \(eSCI_IFSR2\)](#) is set.

The application can retrieve the received data by subsequent read access from [LIN Receive Register \(eSCI_LRR\)](#) after checking the RXRDY flag. The application should clear the RXRDY flag immediately after reading the [LIN Receive Register \(eSCI_LRR\)](#).

After the reception of the configured number of data from the slave, the module starts the reception of the configured CRC and Checksum byte fields. These data are not transferred into the [LIN Receive Register \(eSCI_LRR\)](#). The CRC and Checksum checking is performed internally. In case of errors, they will be reported as described in [Section 26.4.6.5, LIN Error Reporting](#).

After the reception of the checksum field of the LIN RX frame, the FRC interrupt flag in the [Interrupt Flag and Status Register 2 \(eSCI_IFSR2\)](#) is set.

26.4.6.4.2 DMA Controlled LIN RX Frames generation

In this mode, the eSCI module controls the generation of LIN RX frame header and the reception of the frame data automatically and utilizes the two connected DMA channels. A block diagram which presents an overview of the DMA Controlled LIN RX Frame generation and reception is shown in [Figure 26-40](#). The content of the header fields in the memory is the same as described in [LIN Transmit Register \(eSCI_LTR\) - LIN RX frame generation](#). The TX DMA channel is used to fetch the LIN RX frame header and control information. The RX DMA channel is used to transfer the received frame data into the memory.

When new data required for transmission, the module generates the transmit DMA request and the DMA controller delivers the required data. When new data was received, the module generates the receive DMA request and the DMA controller retrieves the provided data.

The application request the eSCI module to enter this mode by setting the RXDMA bit in the [Control Register 2 \(eSCI_CR2\)](#). From this point in time, the module start the generation of DMA requests and frame transmission and reception. Before entering this mode, the application should perform the following actions:

1. Configure the module for LIN mode.
2. Enable transmitter and receiver by setting TE and RE in [Control Register 1 \(eSCI_CR1\)](#) to 1.
3. Setup the two DMA controller channels and provide frame header data in system memory.

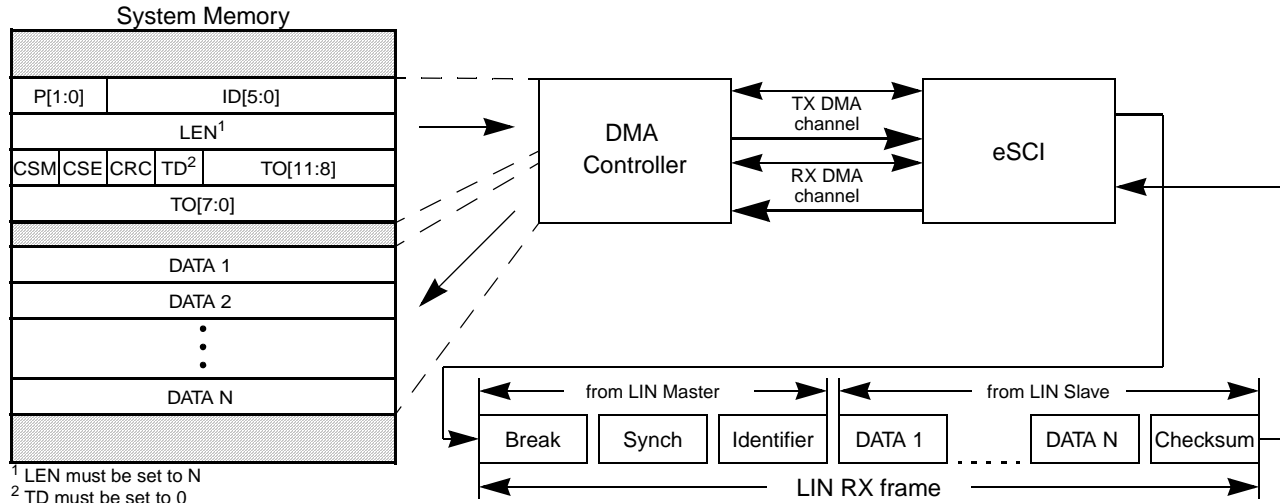

Figure 26-41. DMA Controlled LIN RX Frame generation and reception

26.4.6.5 LIN Error Reporting

This section describes error checking and the signaling of detected errors in LIN mode.

26.4.6.5.1 Physical Bus Error Detection

If the receiver input is sampled 0 for at least 31 sample clock cycles after the start of the transmission of a LIN frame, the physical bus error flag PBERR in the [Interrupt Flag and Status Register 2 \(eSCI_IFSR2\)](#) will be set.

26.4.6.5.2 Unrequested Activity Detection

If an unrequested byte is received (i.e. a byte which is not part of an RX frame) which is not recognized as a wakeup or break character, the bit error flag BERR in the [Interrupt Flag and Status Register 2 \(eSCI_IFSR2\)](#) is set. In addition the RXRDY flag will also be set, the LINRX register must be read before normal operations can proceed.

26.4.6.5.3 Standard Bit Error Detection

The standard bit error detection is performed on each byte field transmission.

During the transmission of the frame header and frame data, the receiver is running and receives the signal values on the serial bus. After the complete transmission of a byte field, the eSCI compares the data that was transmitted and the data that was received. If they do not match, the bit error flag BERR in the [Interrupt Flag and Status Register 2 \(eSCI_IFSR2\)](#) is set.

26.4.6.5.4 Fast Bit Error Detection

Fast Bit Error Detection has been designed to allow flagging of LIN bit errors while they occur, rather than flagging them after a byte transmission has completed (see [Figure 26-42](#)).

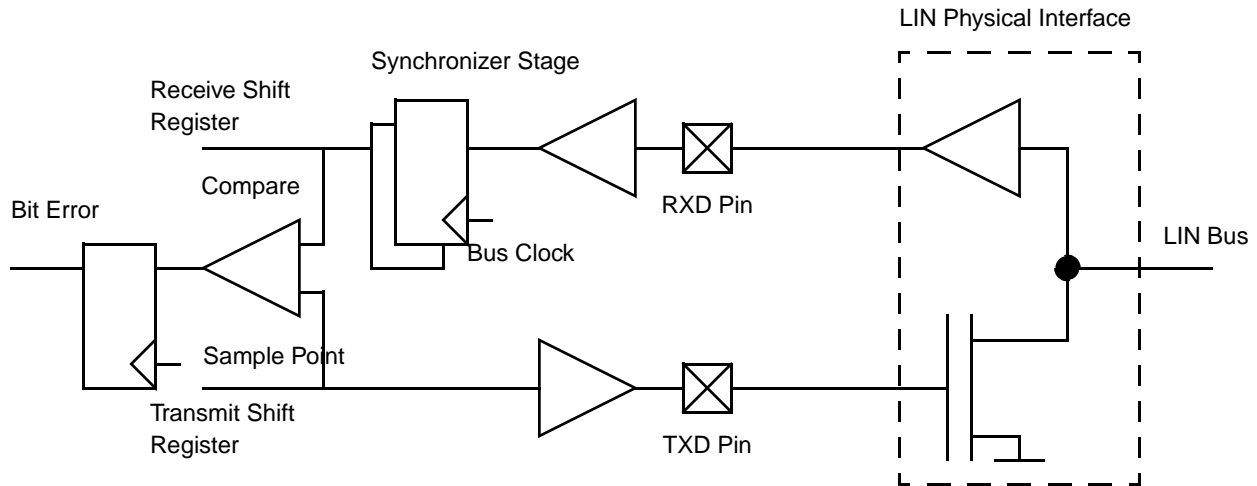

Figure 26-42. Fast Bit Error Detection on a LIN Bus

If fast bit error detection bit FBR in the [Control Register 2 \(eSCI_CR2\)](#) is set the eSCI will compare the transmitted and the received data stream while the transmitter is active (not idle). Once a mismatch between the transmitted data and the received data is detected the following actions are performed the bit error flag BERR will be set.

To adjust to different bus loads the sample point at which the incoming bit is compared to the one which was transmitted can be selected with the BESM bit in the [Control Register 2 \(eSCI_CR2\)](#). If $eSCI_CR2[BESM] = 1$, the comparison will be performed with sample RS13, otherwise with RS9 (see [Figure 26-43](#)) (also see [Section 26.4.5.3.13, Bit Sampling](#)).

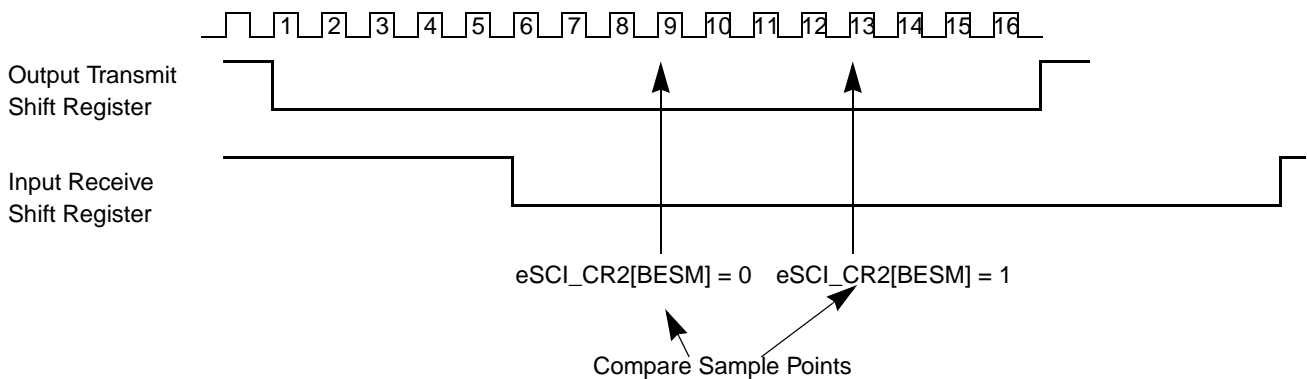

Figure 26-43. Timing Diagram Fast Bit Error Detection

NOTE

To calculate the exact position of the sample point with regard to the RX pin, the delays through the pads and the two Bus Clock cycle delay through the input synchronizer also needs to be taken into account.

26.4.6.5.5 Slave-Not-Responding-Error Detection

The Slave-Not-Responding-Error is defined in [LIN Specification Package Revision 1.3; December 12, 2002](#); 6 ERROR AND EXCEPTION HANDLING. The LIN specification requires that a NO_RESPONSE_ERROR has to be detected if a message frame is not fully completed within the maximum length T_{FRAME_MAX} by any slave task upon transmission of the SYNCH and IDENTIFIER fields. The maximum frame length T_{FRAME_MAX} is defined in [LIN Specification Package Revision 1.3; December 12, 2002](#); 3.3 LENGTH OF MESSAGE FRAME AND BUS SLEEP DETECT, as

$$T_{FRAME_MAX} = (10 \cdot N_{DATA} + 45) \cdot 1.4 \quad \text{Eqn. 26-11}$$

where N_{DATA} is the number of data byte fields of the message frame.

The STO interrupt flag in the [Interrupt Flag and Status Register 2 \(eSCI_IFSR2\)](#) will be set, if an LIN RX frame was not fully received in the amount of time specified in the timeout value field TO in the [LIN Transmit Register \(eSCI_LTR\)](#). The time period starts with the falling edge of the transmitted LIN break character and is specified in units of transmit bits.

To achieve LIN compliant Slave-Not-Responding-Error detection, the timeout value TO in the [LIN Transmit Register \(eSCI_LTR\)](#) field has to be set to T_{FRAME_MAX} when a LIN RX frame is initiated.

26.4.6.5.6 Checksum Error Detection

If the checksum enable bit CSE in the [LIN Transmit Register \(eSCI_LTR\)](#) was set, the checksum checking is performed based on the received checksum byte. The checksum mode is selected by the CSM bit in the [LIN Transmit Register \(eSCI_LTR\)](#). If the value received in the checksum bytes did not match the calculated checksum, the checksum error flag CKERR in the [Interrupt Flag and Status Register 2 \(eSCI_IFSR2\)](#) will be set.

26.4.6.5.7 CRC Error Detection

The CRC checking is performed on the two received CRC bytes CRC1 and CRC2 if the CRC Enhanced LIN frame format was selected by the CRC bit in the [LIN Transmit Register \(eSCI_LTR\)](#). If the value received in the two CRC bytes did not match the calculated CRC pattern, the CRC error flag CERR in the [Interrupt Flag and Status Register 2 \(eSCI_IFSR2\)](#) will be set.

26.4.6.5.8 Overflow Detection

When the receiver has received the next byte field, which should be transferred into the [LIN Receive Register \(eSCI_LRR\)](#), but neither the application nor the RX DMA channel have read data from this register since the last update, the received data overflow flag OVFL in the [Interrupt Flag and Status Register 2 \(eSCI_IFSR2\)](#) will be set. In this case the content of the [LIN Receive Register \(eSCI_LRR\)](#) is not changed. The data received most recently are lost.

26.4.6.6 LIN Wakeup

The section describes the LIN Wakeup behavior of the eSCI module.

26.4.6.6.1 LIN Wakeup Generation

The eSCI module can cause the LIN bus to exit the sleep mode by sending a break character. The application triggers the transmission of a break character by writing 1 to the LIN bus wakeup trigger WU in the [LIN Control Register 1 \(eSCI_LCR1\)](#). After the end of transmission of this break character the transmitter will neither set the TXRDY flag in the [Interrupt Flag and Status Register 2 \(eSCI_IFSR2\)](#) nor start the transmission of frame data until the wakeup delimiter period has been expired. The wakeup delimiter period is defined by the WUD field in the [LIN Control Register 1 \(eSCI_LCR1\)](#).

To generate a valid wakeup character according to LIN 2.0, the eSCI first needs to be programmed to a baud rate lower than 32 kBaud, then WU can be set. Should the application require a higher baud rate, then this rate can be set once the wakeup character has been transmitted.

26.4.6.6.2 LIN Wakeup Reception

If the eSCI receives a valid wakeup condition on the selected receiver input the LIN wakeup flag LWAKE in the [Interrupt Flag and Status Register 2 \(eSCI_IFSR2\)](#) will be set. Since each valid wakeup condition violates the byte field structure the frame error flag FE in the [Interrupt Flag and Status Register 1 \(eSCI_IFSR1\)](#) will be set too.

The eSCI detects the following conditions as valid wakeup conditions:

- Reception of a break signal
- Reception of a LIN 1.x wakeup character (80h, 00h or C0h)
- Reception of a LIN 2.0 wakeup character (low pulse of 250 ms to 5 ms).
To detect LIN 2.0 wakeup characters, the baud rate must to be set to 32k down to 1.6k baud.

26.4.6.7 LIN Protocol Engine Reset

The LIN protocol engine is reset when the LRES bit in the [LIN Control Register 1 \(eSCI_LCR1\)](#) is set to 1. In this case, the LIN protocol engine will no longer initiates new transmissions or receptions. However, ongoing byte transmission or reception is not aborted.

In order to start the LIN Protocol Engine with idle transmitter and receiver processes, the LRES bit should be asserted for the duration of at least one bit.

26.4.7 Interrupts

This section describes the interrupt sources and interrupt request generation.

26.4.7.1 Interrupt Flags and Enables

All interrupt sources, interrupt flags, and interrupt enable bits are listed in [Table 26-36](#). This table indicates the operational modes, where the interrupt flags can be set by the eSCI module.

Table 26-36. eSCI Interrupt Flags and Interrupt Enable Bits

| Interrupt Source | Operational Mode | Interrupt Flag | Interrupt Enable Bit |
|-----------------------|------------------|-------------------|----------------------|
| Transmitter | SCI | eSCI_IFSR1[TDRE] | eSCI_CR1[TIE] |
| Transmitter | SCI, LIN | eSCI_IFSR1[TC] | eSCI_CR1[TCIE] |
| Receiver | SCI | eSCI_IFSR1[RDRF] | eSCI_CR1[RIE] |
| Receiver | SCI | eSCI_IFSR1[IDLE] | eSCI_CR1[ILIE] |
| Receiver | SCI | eSCI_IFSR1[OR] | eSCI_CR2[ORIE] |
| Receiver | SCI, LIN | eSCI_IFSR1[NF] | eSCI_CR2[NFIE] |
| Receiver | SCI, LIN | eSCI_IFSR1[FE] | eSCI_CR2[FEIE] |
| Receiver | SCI | eSCI_IFSR1[PF] | eSCI_CR2[PFIE] |
| Receiver | LIN | eSCI_IFSR1[BERR] | eSCI_CR2[BERRIE] |
| Receiver | LIN | eSCI_IFSR2[RXRDY] | eSCI_LCR1[RXIE] |
| Transmitter | LIN | eSCI_IFSR2[TXRDY] | eSCI_LCR1[TXIE] |
| Receiver | LIN | eSCI_IFSR2[LWAKE] | eSCI_LCR1[WUIE] |
| Receiver | LIN | eSCI_IFSR2[STO] | eSCI_LCR1[STIE] |
| Receiver | LIN | eSCI_IFSR2[PBERR] | eSCI_LCR1[PBIE] |
| Receiver | LIN | eSCI_IFSR2[CERR] | eSCI_LCR1[CIE] |
| Receiver | LIN | eSCI_IFSR2[CKERR] | eSCI_LCR1[CKIE] |
| Receiver | LIN | eSCI_IFSR2[FRC] | eSCI_LCR1[FCIE] |
| Receiver | LIN | eSCI_IFSR2[UREQ] | eSCI_LCR2[URIE] |
| Transmitter, Receiver | LIN | eSCI_IFSR2[OVFL] | eSCI_LCR2[OFIE] |

26.4.7.2 Interrupt Request Generation

The eSCI module provides one hardware interrupt request signal to the systems interrupt controller. This interrupt request signal is asserted if and only if at least one of the interrupt flags and the corresponding interrupt enables are set to 1. Otherwise the interrupt line is deasserted.

26.5 Application Information

26.5.1 SCI Data Frames Separated by Preamble

To separate SCI data frame with preambles with minimum idle line time, use this sequence between messages:

1. write to [SCI Data Register \(ESCI_DR\)](#)
 - this sets the internal iCMT bit which requests the data transmission
2. wait until TDRE in [Interrupt Flag and Status Register 1 \(eSCI_IFSR1\)](#) is set
 - this indicates the start of transmission; the iCMT bit was cleared

3. clear and subsequently set the TE bit in [Control Register 1 \(eSCI_CR1\)](#)
 - this set the internal iPRE bit which requests the preamble transmission
4. write to [SCI Data Register \(ESCI_DR\)](#)
 - this sets the internal iCMT bit which requests the data transmission

The priority scheme of the transmitter which is described in [Table 26-28](#) ensures, that the preamble is transmitted before the data frame.



Chapter 27

Enhanced Queued Analog-to-Digital Converter (EQADC)

27.1 Overview

The Enhanced Queued Analog-to-Digital Converter (EQADC) module provides fast and accurate conversions for a wide range of applications. There are two EQADC modules on the PXR40, EQADC_A and EQADC_B. Each EQADC module provides a parallel interface to two on-chip, independent analog-to-digital converter cores. EQADC_B has a hardware interface to the eight decimation filter blocks on the PXR40. This allows transferring of conversion and filtered values to and from the EQADC and decimation filters without CPU or DMA interaction. Each EQADC module has 24 dedicated external analog input pins, and 16 pins are shared by each module.

The EQADC transfers commands from multiple Command FIFOs (CFIFOs) to the on-chip ADCs. The multiple Result FIFOs (RFIFOs) can receive data from the on-chip ADCs or from an on-chip DSP module (decimation filters). Data from the on-chip ADCs can be routed to the side interface, processed by the decimation filters and then routed back through the side interface to the RFIFOs. The EQADC supports software and external hardware triggers (via package pins) from other blocks (eTPU and eMIOS) to initiate transfers of commands from the CFIFOs to the on-chip ADCs. It also monitors the fill level of the CFIFOs and RFIFOs, and accordingly generates DMA or interrupt requests to control data movement between the FIFOs and the system memory.

27.1.1 Analog to Digital Conversion Sub-system

Figure 27-1 shows how two eQADC modules fit into the overall analog to digital conversion sub-system.

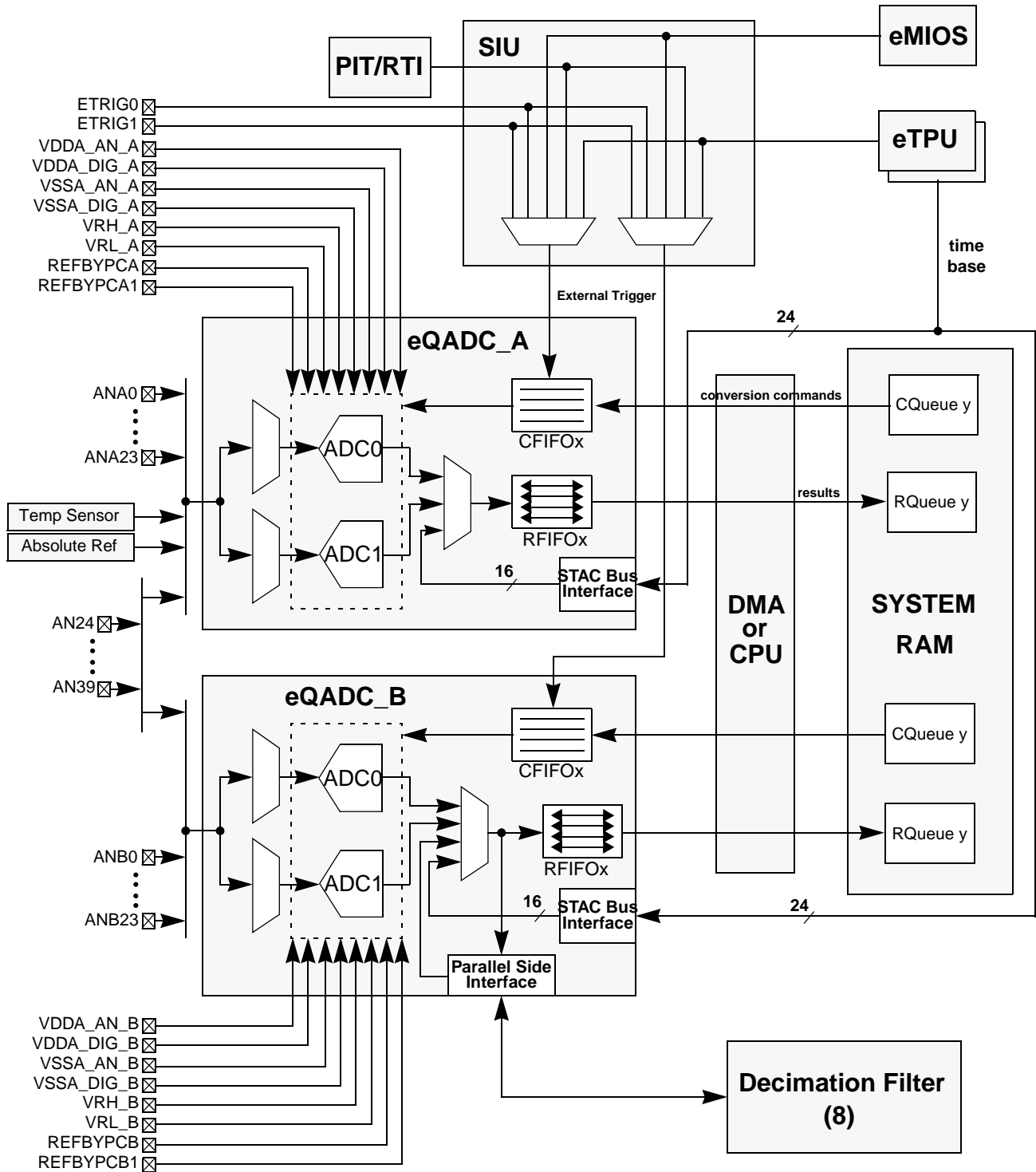

Figure 27-1. Analog to Digital Conversion Sub-system

27.2 Block Diagram

Figure 27-2 is the block diagram for an EQADC block (Table 27-1 describes the main sub-blocks).

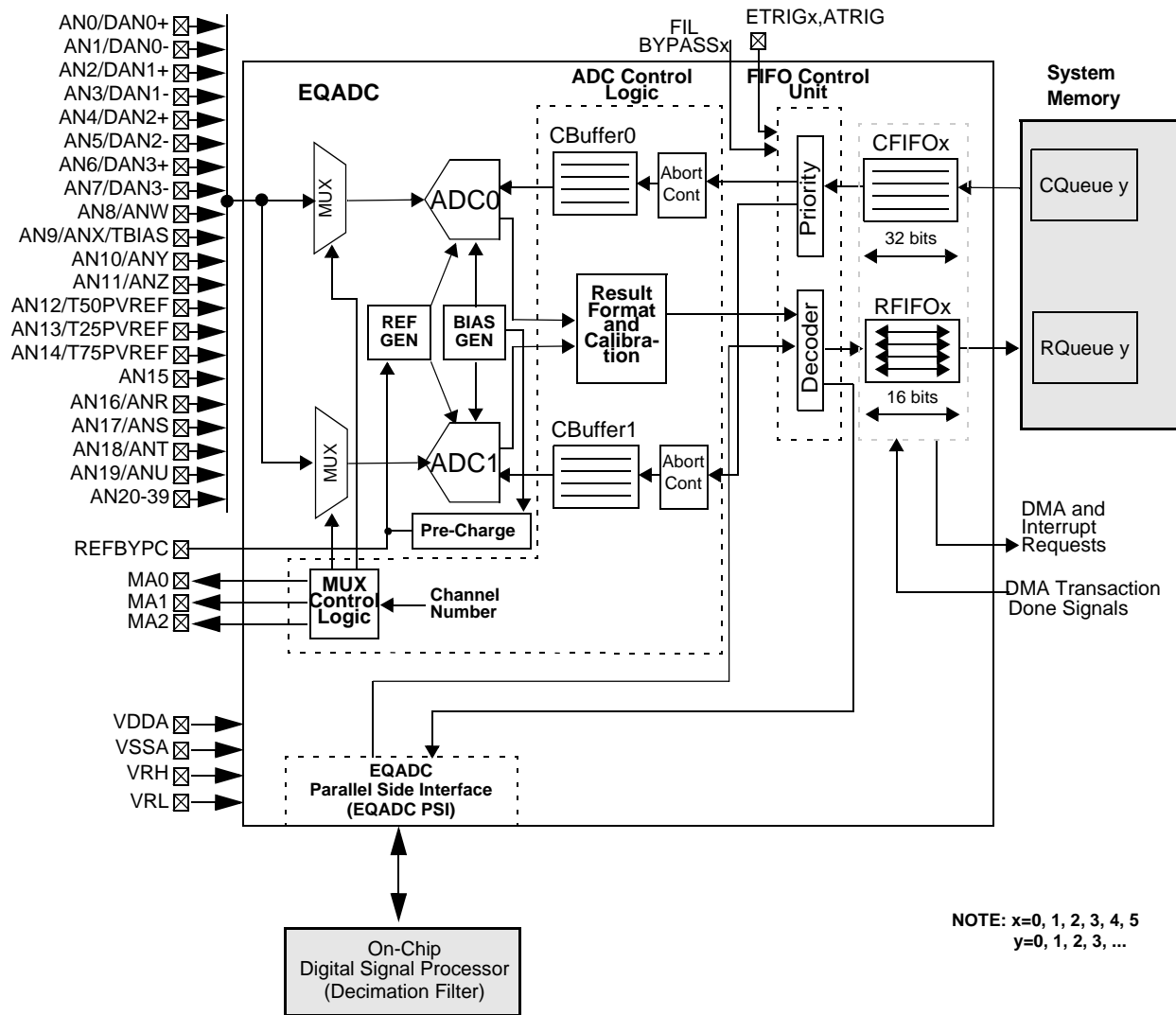

Figure 27-2. EQADC Block Diagram

Table 27-1 shows the primary components inside the EQADC.

Table 27-1. EQADC Primary Component Descriptions

| Component | Function |
|---|---|
| FIFO Control Unit | Controls the CFIFOs and the RFIFOs: <ul style="list-style-type: none"> • Prioritizes the CFIFOs to determine which CFIFOs will have their commands transferred. • Supports software and hardware triggers to start command transfers from a particular CFIFO. • Decodes command data from the CFIFOs and, accordingly, sends these commands to one of the two on-chip ADCs. • Decodes result data from on-chip ADCs and transfers data to the appropriate RFIFO or to the parallel side interface. |
| ADC Control Logic | Manages the execution of commands bound for on-chip ADCs: <ul style="list-style-type: none"> • interfaces with the CFIFOs via two 2-entry command buffers (CBuffers) with abort control and with the RFIFOs via the Result Format and Calibration Sub-Block. • Buffers command data for execution. • Decodes command data and, accordingly, generates control signals for the two on-chip ADCs. • Detects abort requests, stores aborted commands and buffers immediate conversion commands. • Formats and calibrates conversion result data coming from the on-chip ADCs. • Generates the internal multiplexer control signals and the select signals used by the external multiplexers. |
| EQADC Parallel Side Interface (EQADC PSI) | Allows for a full duplex, synchronous, parallel communication between the EQADC and decimation filters. |

Figure 27-2 also depicts data flow through the EQADC. Commands are contained in system memory in a user defined data structure. The most likely data structure to be used is a queue (as shown in Figure 27-2¹). Command data is moved from the command queue (CQueue) to the CFIFOs by either the host CPU or by the system DMA controller. Once a CFIFO is triggered and becomes the highest priority CFIFO using a certain CBuffer, command data is transferred from the CFIFO to the on-chip ADCs. The ADC executes the command, and the result is moved through the *Result Format and Calibration Sub-Block* to either the side interface or to the RFIFO. Data from the on-chip companion module (decimation filter) bypasses the *Result Format and Calibration Sub-Block* and is moved directly to its specified RFIFO. When data is stored in an RFIFO, data is moved from the RFIFO by the host CPU or by the system DMA controller to a data structure in system memory as a result queue (RQueue).

If you are familiar with the QADC, the EQADC system upgrades the functionality provided by that block. Refer to Section 27.8.7, *EQADC Versus QADC*, for a comparison between the EQADC and QADC.

27.2.1 Features

Each EQADC block includes these distinctive features (except where noted):

1. Command and result data can be stored in system memory in any user defined data structure. However, in this document it will be assumed that the data structure of choice is a queue, since it is the most likely data structure to be used and because queues are the only type of data structure supported by the DMAC.

- Two independent on-chip RSD Cyclic ADCs
 - 8, 10, and 12 bits AD Resolution
 - Selectable common mode conversion range (0–5V; 0–2.5V; 0–1.25V)
 - Differential conversions
 - Differential channels include variable gain amplifier for improved dynamic range (x1; x2; x4)
 - Differential channels include programmable pull-up and pull-down resistors for biasing and sensor diagnostics (200k ohms; 100k ohms; 5k ohms)
 - Sample times of 2 (default), 8, 64 or 128 ADC clock cycles
 - Each conversion result can be marked with an imported timestamp from the eTPU, or an independent timestamp
 - Parallel interface to EQADC CFIFOs and RFIFOs
 - Supports both right-justified unsigned and signed formats for conversion results
 - Two REFBYPC pins for each EQADC module: REFBYPC25 and REFBYPC75
 - Temperature sensor (available only to the primary ADC pair (eQADC_A's ADC0 and ADC1)
 - Ability to directly measure Vdd
- Automatic application of ADC calibration constants
- Parallel Side Interface allows eQADC_B to route conversion results without CPU intervention to the Decimation Filter block for signal processing
- Priority Based CFIFOs
 - Supports six CFIFOs with fixed priority. The lower the CFIFO number, the higher its priority. When commands of distinct CFIFOs are bound for the same CBuffer, the higher priority CFIFO is always served first.
 - Immediate conversion command feature with conversion abort control
 - Streaming mode operation of CFIFO0 to execute defined commands multiple times
 - Supports software and several hardware trigger modes to arm a particular CFIFO
 - Generates interrupt when command coherency is not achieved
- External (to the eQADC) Hardware Triggers
 - Supports rising edge, falling edge, high level and low level triggers
 - Supports configurable digital filter
 - Supports controls to bypass the trigger digital filters (refer to the SIU chapter)
- Two Triggers operation mode for queue0
 - Additional internal trigger (not filtered) called Advance trigger that is used to enable the external trigger of queue0 and to control the loop behavior of CFIFO0 (only available on EQADC_B)
- Supports 4 to 8 external 8-to-1 muxes which can expand the input channel number from 40 to 96

27.3 Modes of Operation

This section describes the operation modes of the EQADC.

27.3.1 Normal Mode

This is the default operational mode when the EQADC is not in streaming mode or background debug or stop mode.

27.3.2 Streaming Mode

This mode is characterized by two main aspects: the abort action by CFIFO0 in any current conversion process started from another queue, and the loop behavior of the CFIFO0.

In some applications, there may be sequences of identical commands each spaced only by a few microseconds. To reduce the DMA data transfer, in this mode a short command queue can be stored in CFIFO0 and repeatedly be executed based on a timed trigger, but advance to the next (repeating) sequence of commands based on another device's internal trigger.

The CFIFO0 delivers commands to the ADC as before, but those commands are not 'invalidated' after they are sent (in fact, they are 'invalidated' only because the Transfer Next Data Pointer has moved on). When it encounters these repeated commands the CFIFO0 only fills once, using the DMA as usual, until either it is full or a command with End-of-Queue is encountered. Thereafter the sub-queue repeats/wraps. The number of commands loaded is unaffected by the delivery of commands once the streaming mode is configured, since no commands loaded are invalidated even if sent before all the queue is loaded.

The number of entries in the CFIFO0 is extended to eight (configurable). This is to facilitate the targeted applications. The repeating subqueue must be contained within the eight CFIFO0 entries.

To maintain compatibility, CFIFO0 by default operates as it does before, without streaming and with four entries. Streaming, and additional entries, can be enabled independently.

Streaming mode is selected as another mode for queue 0 using the configuration bits in the EQADC_CFCR register. Streaming mode makes use of an additional bit in the Conversion Command Word (CCW); this bit is called 'Repeat'. The purpose of this bit is to mark in the command queue, where to start a repeating sequence.

Streaming mode requires 2 trigger inputs. The standard queue 0 trigger, in this mode referred to as 'Repeat Trigger' and a second internal trigger input to the eQADC called 'Advance' trigger.

27.3.3 Debug Mode

Upon a debug mode entry request, EQADC behavior will vary according to the status of the DBG field in the EQADC_MCR. If DBG is programmed to 0b00, the debug mode entry request is ignored. If DBG is programmed to 0b10 or to 0b11, the EQADC will enter debug mode.

During debug mode, the EQADC will not transfer commands from any CFIFOs, no data will be returned to any RFIFO, no hardware trigger event will be captured, and all EQADC registers can be accessed as in Normal mode. The latter implies that CFIFOs can still be triggered using software triggers, since no scheme is implemented to write-protect registers during debug mode. DMA and interrupt requests continue to be generated as in Normal Mode.

If at the time the debug mode entry request is detected, there are commands in the on-chip CBuffers that were already under execution, these commands will be completed but the generated results, if any, will not

be sent to the RFIFOs until debug mode is exited. Commands whose execution has not started will not be executed until debug mode is exited. The clock associated with an on-chip ADC stops, during its low phase, after the ADC ceases executing commands. The time base counter will only stop after all on-chip ADCs cease executing commands.

When exiting debug mode, the EQADC relies on the CFIFO operation modes and on the CFIFO status to determine the next command entry to transfer.

The EQADC's internal behavior after the debug mode entry request is detected differs depending on the status of command transfers.

- No command transfer is in progress.

The EQADC immediately halts future command transfers from any CFIFO.

- Command transfer is in progress.

EQADC will complete the transfer and update CFIFO status before halting future command transfers from any CFIFO. Command transfers to the internal CBuffers are considered completed when a command is written to the buffers.

27.3.4 Stop Mode

Upon a stop mode entry request detection, the EQADC progressively halts its operations until it reaches a static, stable state from which it can recover when returning to Normal mode. EQADC then asserts an acknowledge signal, indicating that it is static and that the clock input can be stopped. The latter implies that, as long as the platform clock is running, CFIFOs can still be triggered using software triggers, since no scheme is implemented to write-protect registers during stop mode.

If at the time the stop mode entry request is detected, there are commands in the on-chip CBuffers that were already under execution, these commands will be completed but the generated results, if any, will not be sent to the RFIFOs until stop mode is exited. Commands whose execution has not started will not be executed until stop mode is exited.

After these remaining commands are executed, the clock input to the ADCs and the bias generator circuit is stopped. The ADC clock stops during its low phase. The time base counter will only stop after all on-chip ADCs cease executing commands. Only then, the stop acknowledge signal is asserted. When exiting stop mode, the EQADC relies on the CFIFO operation modes and on the CFIFO status to determine the next command entry to transfer.

The EQADC internal behavior after the stop mode entry request is detected differs depending on the status of the command transfer.

- No command transfer is in progress

The EQADC immediately halts future command transfers from any CFIFO.

- Command transfer is in progress

EQADC will complete the transfer and update CFIFO status before halting future command transfers from any CFIFO. Command transfers to the internal CBuffers are considered completed when a command is written to the buffers.

27.4 External Signal Description

27.4.1 Overview

The following is a list of external pins (applies to both EQADC_A and EQADC_B).

NOTE

At chip integration level, some of the digital and analog signals listed here might share pins or not be available external to the chip. Refer to the Signals chapter for details.

Table 27-2. eQADC Signals

| Name | Port | Function | Reset State | Type |
|------------------------|----------------|--|-------------|--------|
| AN0/DAN0+ ¹ | Input | Single-ended analog input / Differential analog input positive terminal | — | Analog |
| AN1/DAN0- ¹ | Input | Single-ended analog input / Differential analog input negative terminal | — | Analog |
| AN2/DAN1+ ¹ | Input | Single-ended analog input / Differential analog input positive terminal | — | Analog |
| AN3/DAN1- ¹ | Input | Single-ended analog input / Differential analog input negative terminal | — | Analog |
| AN4/DAN2+ ¹ | Input | Single-ended analog input / Differential analog input positive terminal | — | Analog |
| AN5/DAN2- ¹ | Input | Single-ended analog input / Differential analog input negative terminal | — | Analog |
| AN6/DAN3+ ¹ | Input | Single-ended analog input / Differential analog input positive terminal | — | Analog |
| AN7/DAN3- ¹ | Input | Single-ended analog input / Differential analog input negative terminal | — | Analog |
| AN8/ANW | Input | Single-ended analog input / Single-ended analog input from external multiplexers | — | Analog |
| AN9/ANX | Input | Single-ended analog input / Single-ended analog input from external multiplexers | — | Analog |
| AN10/ANY | Input | Single-ended analog input/Single-ended analog input from external multiplexers | — | Analog |
| AN11/ANZ | Input | Single-ended analog input / Single-ended analog input from external multiplexers | — | Analog |
| AN12 | Input / Output | Single-ended analog input | — | Analog |
| AN13 | Input / Output | Single-ended analog input | — | Analog |
| AN14 | Input / Output | Single-ended analog input | — | Analog |
| AN15 | Input | Single-ended analog input | — | Analog |
| AN16/ANR ² | Input | Single-ended analog input / Single-ended analog input from external multiplexers | — | Analog |
| AN17/ANS ² | Input | Single-ended analog input / Single-ended analog input from external multiplexers | — | Analog |
| AN18/ANT ² | Input | Single-ended analog input / Single-ended analog input from external multiplexers | — | Analog |

Table 27-2. eQADC Signals (continued)

| Name | Port | Function | Reset State | Type |
|-----------------------|--------|--|-------------|---------|
| AN19/ANU ² | Input | Single-ended analog input / Single-ended analog input from external multiplexers | — | Analog |
| AN20–AN39 | Input | Single-ended analog inputs | — | Analog |
| MA0 | Output | External multiplexer control signal | 0 | Digital |
| MA1 | Output | External multiplexer control signal | 0 | Digital |
| MA2 | Output | External multiplexer control signal | 0 | Digital |
| VDDA | Input | Analog Positive Power Supply | — | Power |
| VSSA | Input | Analog Negative Power Supply | — | Power |
| VRH | Input | Voltage Reference High | — | Power |
| VRL | Input | Voltage Reference Low | — | Power |
| REFBYPC | Input | External Bypass capacitor Pin | — | Power |
| ETRIG0 | Input | External trigger for CFIFO0 | — | Digital |
| ETRIG1 | Input | External trigger for CFIFO1 | — | Digital |
| ETRIG2 | Input | External trigger for CFIFO2 | — | Digital |
| ETRIG3 | Input | External trigger for CFIFO3 | — | Digital |
| ETRIG4 | Input | External trigger for CFIFO4 | — | Digital |
| ETRIG5 | Input | External trigger for CFIFO5 | — | Digital |

NOTES:

¹ During and just after POR negates, internal pull resistors can be enabled, resulting in as much as 4 mA of current draw. The pull resistors are disabled when the system clock propagates through the device.

² Can be disabled or not using configuration parameters.

27.4.2 Detailed Signal Descriptions

Table 27-3. EQADC External Signals

| Signal Name | Description |
|------------------------|---|
| AN0/DAN0+ ¹ | Single-ended analog input/Differential analog input positive terminal. AN0 is a single-ended analog input to the two on-chip ADCs. DAN0+ is the positive terminal of the differential analog input DAN0 (DAN0+ - DAN0-). |
| AN1/DAN0- ¹ | Single-ended analog input/Differential analog input negative terminal. AN1 is a single-ended analog input to the two on-chip ADCs. DAN0- is the negative terminal of the differential analog input DAN0 (DAN0+ - DAN0-). |
| AN2/DAN1+ ¹ | Single-ended analog input/Differential analog input positive terminal. AN2 is a single-ended analog input to the two on-chip ADCs. DAN1+ is the positive terminal of the differential analog input DAN1 (DAN1+ - DAN1-). |
| AN3/DAN1- ¹ | Single-ended analog input/Differential analog input negative terminal. AN3 is a single-ended analog input to the two on-chip ADCs. DAN1- is the negative terminal of the differential analog input DAN1 (DAN1+ - DAN1-). |
| AN4/DAN2+ ¹ | Single-ended analog input/Differential analog input positive terminal. AN4 is a single-ended analog input to the two on-chip ADCs. DAN2+ is the positive terminal of the differential analog input DAN2 (DAN2+ - DAN2-). |

Table 27-3. EQADC External Signals (continued)

| Signal Name | Description |
|------------------------|---|
| AN5/DAN2 ⁻¹ | Single-ended analog input/Differential analog input negative terminal. AN5 is a single-ended analog input to the two on-chip ADCs. DAN2 ⁻ is the negative terminal of the differential analog input DAN2 (DAN2 ⁺ - DAN2 ⁻). |
| AN6/DAN3 ⁺¹ | Single-ended analog input/Differential analog input positive terminal. AN6 is a single-ended analog input to the two on-chip ADCs. DAN3 ⁺ is the positive terminal of the differential analog input DAN3 (DAN3 ⁺ - DAN3 ⁻). |
| AN7/DAN3 ⁻¹ | Single-ended analog input/Differential analog input negative terminal. AN7 is a single-ended analog input to the two on-chip ADCs. DAN3 ⁻ is the negative terminal of the differential analog input DAN3 (DAN3 ⁺ - DAN3 ⁻). |
| AN8/ANW | Single-ended analog input/ Single-ended analog input from external multiplexers. AN8 is a single-ended analog input to the two on-chip ADCs. ANW is a single-ended analog input to one of the on-chip ADCs in external multiplexed mode. |
| AN9/ANX | Single-ended analog input/ Single-ended analog input from external multiplexers/Test Bias. AN9 is a single-ended analog input to the two on-chip ADCs. ANX is a single-ended analog input to one of the on-chip ADCs in external multiplexed mode. |
| AN10/ANY | Single-ended analog input/ Single-ended analog input from external multiplexers. AN10 is a single-ended analog input to the two on-chip ADCs. ANY is a single-ended analog input to one of the on-chip ADCs in external multiplexed mode. |
| AN11/ANZ | Single-ended analog input/ Single-ended analog input from external multiplexers. AN11 is a single-ended analog input to the two on-chip ADCs. ANZ is a single-ended analog input to one of the on-chip ADCs in external multiplexed mode. |
| AN12 | Single-ended analog input/ Test 50% VREF analog output. AN12 is a single-ended analog input to the two on-chip ADCs. |
| AN13 | Single-ended analog input/ Test 25% VREF analog output. AN13 is a single-ended analog input to the two on-chip ADCs. |
| AN14 | Single-ended analog input/ Test 75% VREF analog output. AN14 is a single-ended analog input to the two on-chip ADCs. |
| AN15 | Single-ended analog input. AN15 is a single-ended analog inputs to the two on-chip ADCs. |
| AN16/ANR | Single-ended analog input/ Single-ended analog input from external multiplexers. AN16 is a single-ended analog input to the two on-chip ADCs. ANR is a single-ended analog input to one of the on-chip ADCs in external multiplexed mode. The external multiplexing capability is a device option. |
| AN17/ANS | Single-ended analog input/ Single-ended analog input from external multiplexers. AN17 is a single-ended analog input to the two on-chip ADCs. ANS is a single-ended analog input to one of the on-chip ADCs in external multiplexed mode. The external multiplexing capability is a device option. |
| AN18/ANT | Single-ended analog input/ Single-ended analog input from external multiplexers. AN18 is a single-ended analog input to the two on-chip ADCs. ANT is a single-ended analog input to one of the on-chip ADCs in external multiplexed mode. The external multiplexing capability is a device option. |
| AN19/ANU | Single-ended analog input/ Single-ended analog input from external multiplexers. AN19 is a single-ended analog input to the two on-chip ADCs. ANU is a single-ended analog input to one of the on-chip ADCs in external multiplexed mode. The external multiplexing capability is a device option. |

Table 27-3. EQADC External Signals (continued)

| Signal Name | Description |
|----------------------------|---|
| AN20-AN39 | Single-ended analog input. AN20 through AN39 are single-ended analog inputs to the two on-chip ADCs. |
| INA_ADC0_0 - INA_ADC0_9 | (not external to the chip) Single-ended analog input. INA_ADC0_0 through INA_ADC0_9 are single-ended analog inputs to the on-chip ADC0. |
| INA_ADC1_0 - INA_ADC1_9 | (not external to the chip) Single-ended analog input. INA_ADC1_0 through INA_ADC1_9 are single-ended analog inputs to the on-chip ADC1. |
| MA0-MA2 | External multiplexer control signals. MA0, MA1, and MA2 combined form a select signal associated with external multiplexers. |
| VRH, VRL | Voltage reference high and voltage reference low. VRH and VRL are voltage references for the ADCs. VRH is the highest voltage reference, while VRL is the lowest voltage reference. |
| VDDA, VSSA | 5V VDD and VSS for the 5V analog components. VDDA is the positive power supply pin for the ADCs and VSSA is the negative power supply pin for the ADCs. Refer to electrical specifications. |
| REFBYPC | Reference Bypass Capacitor The REFBYPC pin is used to connect an external bypass capacitor between REFBYPC and VRL. The value of this capacitor should be 100nf. This bypass capacitor is used to provide a stable reference voltage for the ADC. |
| ETRIG0-ETRIG5 | External trigger The external trigger signals are for hardware triggering. The EQADC can detect rising edge, falling edge, high level and low level on each of the external trigger signals. ETRIGx triggers CFIFOx. The EQADC also uses digital filters for these external trigger signals. |

NOTES:

- ¹ During and just after POR negates, internal pull resistors can be enabled, resulting in as much as 4 mA of current draw. The pull resistors are disabled when the system clock propagates through the device.

27.5 Pin Mapping to Channel Mapping

Table 27-4 shows the pin mapping to channel mapping to show which signals go to which ADC. For internal and external multiplexing channel assignments, see Table 27-42.

Table 27-4. Pin Mapping to Channel Mapping

| Analog Input Pin 416 package | Function | ADC Number | | eQADC_A Channel Number | eQADC_B Channel Number |
|---------------------------------|----------------------------|------------|---------|------------------------------|------------------------------|
| | | eQADC_A | eQADC_B | | |
| ANA0-ANA23 ¹ | Single ended conversion | 0, 1 | — | 0-23 | — |
| ANB0-ANB23 | Single ended conversion | — | 0,1 | — | 0-23 |
| AN24-AN39 | Single ended conversion | 0, 1 | 0, 1 | 24-39 | 24-39 |
| — | VRH | 0, 1 | 0, 1 | 40 | 40 |
| — | VRL | 0, 1 | 0, 1 | 41 | 41 |
| — | 50% (VRH-VRL) ² | 0, 1 | 0, 1 | 42 | 42 |
| — | 75% (VRH-VRL) | 0, 1 | 0, 1 | 43 | 43 |
| — | 25% (VRH-VRL) | 0, 1 | 0, 1 | 44 | 44 |

Table 27-4. Pin Mapping to Channel Mapping (continued)

| Analog Input Pin 416 package | Function | ADC Number | | eQADC_A Channel Number | eQADC_B Channel Number |
|---------------------------------|----------------------------------|------------|---------|------------------------------|------------------------------|
| | | eQADC_A | eQADC_B | | |
| — | Local Band Gap 1220mV | 0, 1 | — | 45 | 45 |
| ANA8 | ANWA ³ | 0, 1 | 0, 1 | 64–71 | — |
| ANB8 | ANWB ³ | — | 0, 1 | — | 64–71 |
| ANA9 | ANXA ³ | 0, 1 | — | 72–79 | — |
| ANB9 | ANXB ³ | — | 0, 1 | — | 72–79 |
| ANA10 | ANYA ³ | 0, 1 | — | 80–87 | — |
| ANB10 | ANYB ³ | — | 0, 1 | — | 80–87 |
| ANA11 | ANZA ³ | 0, 1 | — | 88–95 | — |
| ANB11 | ANZB ³ | — | 0, 1 | — | 88–95 |
| ANA0 and ANA1 | DANA0+ and DANA0- | 0, 1 | — | 96 | — |
| ANB0 and ANB1 | DANB0+ and DANB0- | — | 0, 1 | — | 96 |
| ANA2 and ANA3 | DANA1+ and DANA1- | 0, 1 | — | 97 | — |
| ANB2 and ANB3 | DANB1+ and DANB1- | — | 0, 1 | — | 97 |
| ANA4 and ANA5 | DANA2+ and DANA2- | 0, 1 | — | 98 | — |
| ANB4 and ANB5 | DANB2+ and DANB2- | — | 0, 1 | — | 98 |
| ANA6 and ANA7 | DANA3+ and DANA3- | 0, 1 | — | 99 | — |
| ANB6 and ANB7 | DANB3+ and DANB3- | — | 0, 1 | — | 99 |
| — | Temperature Sensor | 0, 1 | — | 128 | — |
| — | PMC band gap 0.62 V ⁴ | 0 | — | 145 | — |
| — | VDD | 0 | — | 146 | — |
| — | Internal 1.2 V regulator | 0 | — | 147 | — |
| — | VDDEH1 50% | 0 | — | 162 | — |
| — | VDDEH3 50% | 0 | — | 163 | — |
| — | VDDEH4 50% | 0 | — | 164 | — |
| — | VDDEH5 50% | 0 | — | 165 | — |
| — | VDDEH6 50% | 0 | — | 166 | — |
| — | VDDEH7 50% | 0 | — | 167 | — |
| — | 1.2 V LVD VDD | 0 | — | 180 | — |
| — | 3.3 V Internal regulator | 0 | — | 181 | — |
| — | 3.3 V LVD VDDSYN | 0 | — | 182 | — |
| — | 5.0 V LVD VDDREG | 0 | — | 183 | — |
| — | Standby regulator out | 1 | — | 194 | — |
| — | Standby source bias | 1 | — | 195 | — |

Table 27-4. Pin Mapping to Channel Mapping (continued)

| Analog Input Pin 416 package | Function | ADC Number | | eQADC_A Channel Number | eQADC_B Channel Number |
|---------------------------------|--------------------------------|------------|---------|------------------------------|------------------------------|
| | | eQADC_A | eQADC_B | | |
| — | 4.75 V LVD VDDA (ADC band gap) | 1 | — | 196 | — |
| ANA16 | ANRA ³ | 0, 1 | — | 224–231 | — |
| ANB16 | ANRB ³ | — | 0, 1 | — | 224–231 |
| ANA17 | ANSA ³ | 0, 1 | — | 232–239 | — |
| ANB17 | ANSB ³ | — | 0, 1 | — | 232–239 |
| ANA18 | ANTA ³ | 0, 1 | — | 240–247 | — |
| ANB18 | ANTB ³ | — | 0, 1 | — | 240–247 |
| ANA19 | ANUA ³ | 0, 1 | — | 248–255 | — |
| ANB19 | ANUB ³ | — | 0, 1 | — | 248–255 |

NOTES:

- ¹ ANx8–ANx11 and ANx16–ANx19 have alternate functions when used with an external multiplexer.
- ² After calibration, the 50% reference point will read approximately 20 mV below 50%(VRH - VRL). The 50% reference point should not be used to calibrate the EQADC. Use the 25% and 75% reference points to calibrate the EQADC.
- ³ This function is when using an external multiplexer.
- ⁴ Refer to the PMC chapter.

27.6 Memory Map/Register Definition

This section provides memory maps and detailed descriptions of all registers. Data written to or read from reserved areas of the memory map is undefined.

27.6.1 EQADC Memory Map

This section provides memory maps for the EQADC block.

Table 27-5. EQADC Memory Map

| Address Offset ¹ | Register | Bits | Access | Reset Value | Section/Page |
|--------------------------------|--|------|--------|-------------|-----------------------------|
| 0x0000 | EQADC_MCR—EQADC Module Configuration Register | 32 | R/W | 0x0000_0000 | 27.6.2.1/16 |
| 0x0004 | Reserved | | — | | |
| 0x0008 | Reserved | | — | | |
| 0x000C | EQADC_ETDFR—EQADC External Trigger Digital Filter Register | 32 | R/W | 0x0000_0000 | 27.6.2.2/17 |
| 0x0010 | EQADC_CFPR0—EQADC CFIFO Push Register 0 | 32 | W | 0x0000_0000 | 27.6.2.3/18 |
| 0x0014 | EQADC_CFPR1—EQADC CFIFO Push Register 1 | 32 | W | 0x0000_0000 | |
| 0x0018 | EQADC_CFPR2—EQADC CFIFO Push Register 2 | 32 | W | 0x0000_0000 | |
| 0x001C | EQADC_CFPR3—EQADC CFIFO Push Register 3 | 32 | W | 0x0000_0000 | |
| 0x0020 | EQADC_CFPR4—EQADC CFIFO Push Register 4 | 32 | W | 0x0000_0000 | |
| 0x0024 | EQADC_CFPR5—EQADC CFIFO Push Register 5 | 32 | W | 0x0000_0000 | |
| 0x0028 | Reserved | | — | | |

Table 27-5. EQADC Memory Map (continued)

| Address Offset ¹ | Register | Bits | Access | Reset Value | Section/Page |
|-----------------------------|--|------|--------|-------------|-----------------------------|
| 0x002C | Reserved | | — | | |
| 0x0030 | EQADC_RFPR0—EQADC Result FIFO Pop Register 0 | 32 | R | 0x0000_0000 | 27.6.2.4/19 |
| 0x0034 | EQADC_RFPR1—EQADC Result FIFO Pop Register 1 | 32 | R | 0x0000_0000 | |
| 0x0038 | EQADC_RFPR2—EQADC Result FIFO Pop Register 2 | 32 | R | 0x0000_0000 | |
| 0x003C | EQADC_RFPR3—EQADC Result FIFO Pop Register 3 | 32 | R | 0x0000_0000 | |
| 0x0040 | EQADC_RFPR4—EQADC Result FIFO Pop Register 4 | 32 | R | 0x0000_0000 | |
| 0x0044 | EQADC_RFPR5—EQADC Result FIFO Pop Register 5 | 32 | R | 0x0000_0000 | |
| 0x0048 | Reserved | | — | | — |
| 0x004C | Reserved | | — | | — |
| 0x0050 | EQADC_CFCR0-1—EQADC CFIFO Control Register 0 and 1 | 32 | R/W | 0x0000_0000 | 27.6.2.5/19 |
| 0x0054 | EQADC_CFCR2-3—EQADC CFIFO Control Register 2 and 3 | 32 | R/W | 0x0000_0000 | |
| 0x0058 | EQADC_CFCR4-5—EQADC CFIFO Control Register 4 and 5 | 32 | R/W | 0x0000_0000 | |
| 0x005C | Reserved | | — | | — |
| 0x0060 | EQADC_IDCR0—EQADC Interrupt and DMA Control Register 0 | 32 | R/W | 0x0000_0000 | 27.6.2.6/22 |
| 0x0064 | EQADC_IDCR1—EQADC Interrupt and DMA Control Register 1 | 32 | R/W | 0x0000_0000 | |
| 0x0068 | EQADC_IDCR2—EQADC Interrupt and DMA Control Register 2 | 32 | R/W | 0x0000_0000 | |
| 0x006C | Reserved | | — | | — |
| 0x0070 | EQADC_FISR0—EQADC FIFO and Interrupt Status Register 0 | 32 | R/W | 0x0200_0000 | 27.6.2.7/25 |
| 0x0074 | EQADC_FISR1—EQADC FIFO and Interrupt Status Register 1 | 32 | R/W | 0x0200_0000 | |
| 0x0078 | EQADC_FISR2—EQADC FIFO and Interrupt Status Register 2 | 32 | R/W | 0x0200_0000 | |
| 0x007C | EQADC_FISR3—EQADC FIFO and Interrupt Status Register 3 | 32 | R/W | 0x0200_0000 | |
| 0x0080 | EQADC_FISR4—EQADC FIFO and Interrupt Status Register 4 | 32 | R/W | 0x0200_0000 | |
| 0x0084 | EQADC_FISR5—EQADC FIFO and Interrupt Status Register 5 | 32 | R/W | 0x0200_0000 | |
| 0x0088 | Reserved | | — | | — |
| 0x008C | Reserved | | — | | — |
| 0x0090 | EQADC_CFTCR0—EQADC CFIFO Transfer Counter Register 0 | 32 | R/W | 0x0000_0000 | 27.6.2.8/29 |
| 0x0094 | EQADC_CFTCR1—EQADC CFIFO Transfer Counter Register 1 | 32 | R/W | 0x0000_0000 | |
| 0x0098 | EQADC_CFTCR2—EQADC CFIFO Transfer Counter Register 2 | 32 | R/W | 0x0000_0000 | |
| 0x009C | Reserved | | — | | — |

Table 27-5. EQADC Memory Map (continued)

| Address Offset ¹ | Register | Bits | Access | Reset Value | Section/Page |
|-----------------------------|--|------|--------|-------------|------------------------------|
| 0x00A0 | EQADC_CFSSR0—EQADC CFIFO Status Snapshot Register 0 | 32 | R | 0x0000_7800 | 27.6.2.9/30 |
| 0x00A4 | EQADC_CFSSR1—EQADC CFIFO Status Snapshot Register 1 | 32 | R | 0x0000_7800 | |
| 0x00A8 | Reserved | | — | | — |
| 0x00AC | EQADC_CFSSR—EQADC CFIFO Status Register | 32 | R | 0x0000_0000 | 27.6.2.10/32 |
| 0x00B0–0x00CC | Reserved | | — | | — |
| 0x00D0 | EQADC_REDLCCR—EQADC Red Line Client Configuration Register | 32 | | 0x0000_0000 | 27.6.2.11/33 |
| 0x00D4–0x00FC | Reserved | | — | | — |
| 0x0100–0x010C | EQADC_CF0Rw—EQADC CFIFO0 Registers (w=0, .., 3) | 32 | R | 0x0000_0000 | 27.6.2.12/34 |
| 0x0110–0x011C | EQADC_CF0ERw—EQADC CFIFO0 Extension Registers (w=0, .., 3) | 32 | R | 0x0000_0000 | 27.6.2.13/37 |
| 0x0120–0x013C | Reserved | | — | | — |
| 0x0140–0x014C | EQADC_CF1Rw—EQADC CFIFO1 Registers (w=0, .., 3) | 32 | R | 0x0000_0000 | 27.6.2.13/37 |
| 0x0150–0x017C | Reserved | | — | | — |
| 0x0180–0x018C | EQADC_CF2Rw—EQADC CFIFO2 Registers (w=0, .., 3) | 32 | R | 0x0000_0000 | 27.6.2.13/37 |
| 0x0190–0x01BC | Reserved | | — | | — |
| 0x01C0–0x01CC | EQADC_CF3Rw—EQADC CFIFO3 Registers (w=0, .., 3) | 32 | R | 0x0000_0000 | 27.6.2.13/37 |
| 0x01D0–0x01FC | Reserved | | — | | — |
| 0x0200–0x020C | EQADC_CF4Rw—EQADC CFIFO4 Registers (w=0, .., 3) | 32 | R | 0x0000_0000 | 27.6.2.13/37 |
| 0x0210–0x023C | Reserved | | — | | — |
| 0x0240–0x024C | EQADC_CF5Rw—EQADC CFIFO5 Registers (w=0, .., 3) | 32 | R | 0x0000_0000 | 27.6.2.13/37 |
| 0x0250–0x02FC | Reserved | | — | | — |
| 0x0300–0x030C | EQADC_RF0Rw—EQADC RFIFO0 Registers (w=0, .., 3) | 32 | R | 0x0000_0000 | 27.6.2.14/37 |
| 0x0310–0x033C | Reserved | | — | | — |
| 0x0340–0x034C | EQADC_RF1Rw—EQADC RFIFO1 Registers (w=0, .., 3) | 32 | R | 0x0000_0000 | 27.6.2.14/37 |
| 0x0350–0x037C | Reserved | | — | | — |

Table 27-5. EQADC Memory Map (continued)

| Address Offset ¹ | Register | Bits | Access | Reset Value | Section/Page |
|-----------------------------|--|------|--------|-------------|------------------------------|
| 0x0380–0x038C | EQADC_RF2Rw—EQADC RFIFO2 Registers (w=0, ..., 3) | 32 | R | 0x0000_0000 | 27.6.2.14/37 |
| 0x0390–0x03BC | Reserved | | — | | — |
| 0x03C0–0x03CC | EQADC_RF3Rw—EQADC RFIFO3 Registers (w=0, ..., 3) | 32 | R | 0x0000_0000 | 27.6.2.14/37 |
| 0x03D0–0x03FC | Reserved | | — | | — |
| 0x0400–0x040C | EQADC_RF4Rw—EQADC RFIFO4 Registers (w=0, ..., 3) | 32 | R | 0x0000_0000 | 27.6.2.14/37 |
| 0x0410–0x043C | Reserved | | — | | — |
| 0x0440–0x044C | EQADC_RF5Rw—EQADC RFIFO5 Registers (w=0, ..., 3) | 32 | R | 0x0000_0000 | 27.6.2.14/37 |
| 0x0450–0x047C | Reserved | | — | | — |

NOTES:

- ¹ EQADC_A_BASE = 0xFFFF8_0000
- EQADC_B_BASE = 0xFFFF8_4000

27.6.2 EQADC Register Descriptions

27.6.2.1 EQADC Module Configuration Register (EQADC_MCR)

The EQADC Module Configuration Register (EQADC_MCR) contains bits used to control how the EQADC responds to a debug mode entry request.

Address: 0x0000

Access: User read/write

| | 0 | 1 | 2 | 3 | 4 | 5 | 6 | 7 | 8 | 9 | 10 | 11 | 12 | 13 | 14 | 15 |
|-------|----|----|----|----|----|----|----|----|-------|-------|----|----|----|----|----|-----|
| R | 0 | 0 | 0 | 0 | 0 | 0 | 0 | 0 | 0 | 0 | 0 | 0 | 0 | 0 | 0 | 0 |
| W | | | | | | | | | | | | | | | | |
| Reset | 0 | 0 | 0 | 0 | 0 | 0 | 0 | 0 | 0 | 0 | 0 | 0 | 0 | 0 | 0 | 0 |
| | 16 | 17 | 18 | 19 | 20 | 21 | 22 | 23 | 24 | 25 | 26 | 27 | 28 | 29 | 30 | 31 |
| R | 0 | 0 | 0 | 0 | 0 | 0 | 0 | 0 | ICEA0 | ICEA1 | 0 | 0 | | 0 | | |
| W | | | | | | | | | | | | | | | | DBG |
| Reset | 0 | 0 | 0 | 0 | 0 | 0 | 0 | 0 | 0 | 0 | 0 | 0 | 0 | 0 | 0 | 0 |

Figure 27-3. EQADC Module Configuration Register (EQADC_MCR)

Table 27-6. EQADC_MCR Field Descriptions

| Field | Description |
|----------------|--|
| 0–23 | Reserved |
| 24–25 ICEAn | Immediate Conversion Command Enable ADCn (n=0,1). ICEAn enables the EQADC to abort on-chip ADCn current conversion and to start the immediate conversion command from CFIFO0 in the requested ADCn. 0 Disable immediate conversion command request. 1 Enable immediate conversion command request. |
| 2–29 | These bits are reserved and must always be 0b00. |
| 30–31 DBG | Debug enable. The DBG field defines the EQADC response to a debug mode entry request. 00 Do not enter debug mode. 01 Reserved 1x Enter debug mode. |

27.6.2.2 EQADC External Trigger Digital Filter Register (EQADC_ETDFR)

The EQADC External Trigger Digital Filter Register (EQADC_ETDFR) is used to set the minimum time a signal must be held in a logic state on the CFIFO triggers inputs to be recognized as an edge or level gated trigger. The Digital Filter Length field specifies the minimum number of platform clocks that must be counted by the digital filter counter to recognize a logic state change. This filter does not work when the trigger is an internal signal (see SIU chapter), but should be considered when the trigger is an external one.

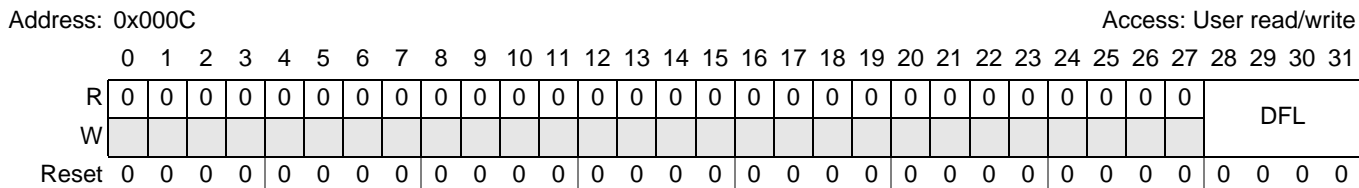

Figure 27-4. EQADC External Trigger Digital Filter Register (EQADC_ETDFR)

Table 27-7. EQADC_ETDFR Field Description

| Field | Description | | | | | | | | | | | | | | | | | | | | | | | | | | | | | | | | | | | | | | | | | | | | | | | | | | | |
|--------------|--|---|---------------------|---|--------|---|-------|--------|---|-------|--------|---|-------|--------|---|-------|--------|----|--------|--------|----|--------|--------|----|--------|--------|-----|---------|--------|-----|---------|--------|-----|---------|--------|------|---------|--------|------|----------|--------|------|----------|--------|------|----------|--------|-------|-----------|--------|-------|-----------|
| 0–27 | Reserved | | | | | | | | | | | | | | | | | | | | | | | | | | | | | | | | | | | | | | | | | | | | | | | | | | | |
| 28–31 DFL | <p>Digital Filter Length. The DFL field specifies the minimum number of platform clocks that must be counted by the digital filter counter to recognize a logic state change. The count specifies the sample period of the digital filter which is calculated according to the following equation:</p> $FilterPeriod = (SystemClockPeriod \times 2^{DFL}) + 1(SystemClockPeriod)$ <p>Minimum clock counts for which an ETRIG signal needs to be stable to be passed through the filter are shown below. Refer to Section 27.7.4.5, Hardware Trigger Event Detection, for more information on the digital filter.</p> <table border="1"> <thead> <tr> <th>DFL[0:3]</th> <th>Minimum Clock Count</th> <th>Minimum Time (ns) (platform clock = 120 MHz)</th> </tr> </thead> <tbody> <tr><td>0b0000</td><td>2</td><td>16.66</td></tr> <tr><td>0b0001</td><td>3</td><td>25.00</td></tr> <tr><td>0b0010</td><td>5</td><td>41.66</td></tr> <tr><td>0b0011</td><td>9</td><td>75.00</td></tr> <tr><td>0b0100</td><td>17</td><td>141.66</td></tr> <tr><td>0b0101</td><td>33</td><td>275.00</td></tr> <tr><td>0b0110</td><td>65</td><td>541.66</td></tr> <tr><td>0b0111</td><td>129</td><td>1075.00</td></tr> <tr><td>0b1000</td><td>257</td><td>2141.66</td></tr> <tr><td>0b1001</td><td>513</td><td>4275.00</td></tr> <tr><td>0b1010</td><td>1025</td><td>8541.66</td></tr> <tr><td>0b1011</td><td>2049</td><td>17075.00</td></tr> <tr><td>0b1100</td><td>4097</td><td>34141.00</td></tr> <tr><td>0b1101</td><td>8193</td><td>68275.00</td></tr> <tr><td>0b1110</td><td>16385</td><td>136541.66</td></tr> <tr><td>0b1111</td><td>32769</td><td>273075.00</td></tr> </tbody> </table> <p>Note: The DFL field must only be written when the MODEx of all CFIFOs are configured to disabled. When the digital filter is bypassed (i.e. for on-chip triggers), the DFL is not considered and the trigger input signal is not filtered.</p> | DFL[0:3] | Minimum Clock Count | Minimum Time (ns) (platform clock = 120 MHz) | 0b0000 | 2 | 16.66 | 0b0001 | 3 | 25.00 | 0b0010 | 5 | 41.66 | 0b0011 | 9 | 75.00 | 0b0100 | 17 | 141.66 | 0b0101 | 33 | 275.00 | 0b0110 | 65 | 541.66 | 0b0111 | 129 | 1075.00 | 0b1000 | 257 | 2141.66 | 0b1001 | 513 | 4275.00 | 0b1010 | 1025 | 8541.66 | 0b1011 | 2049 | 17075.00 | 0b1100 | 4097 | 34141.00 | 0b1101 | 8193 | 68275.00 | 0b1110 | 16385 | 136541.66 | 0b1111 | 32769 | 273075.00 |
| DFL[0:3] | Minimum Clock Count | Minimum Time (ns) (platform clock = 120 MHz) | | | | | | | | | | | | | | | | | | | | | | | | | | | | | | | | | | | | | | | | | | | | | | | | | | |
| 0b0000 | 2 | 16.66 | | | | | | | | | | | | | | | | | | | | | | | | | | | | | | | | | | | | | | | | | | | | | | | | | | |
| 0b0001 | 3 | 25.00 | | | | | | | | | | | | | | | | | | | | | | | | | | | | | | | | | | | | | | | | | | | | | | | | | | |
| 0b0010 | 5 | 41.66 | | | | | | | | | | | | | | | | | | | | | | | | | | | | | | | | | | | | | | | | | | | | | | | | | | |
| 0b0011 | 9 | 75.00 | | | | | | | | | | | | | | | | | | | | | | | | | | | | | | | | | | | | | | | | | | | | | | | | | | |
| 0b0100 | 17 | 141.66 | | | | | | | | | | | | | | | | | | | | | | | | | | | | | | | | | | | | | | | | | | | | | | | | | | |
| 0b0101 | 33 | 275.00 | | | | | | | | | | | | | | | | | | | | | | | | | | | | | | | | | | | | | | | | | | | | | | | | | | |
| 0b0110 | 65 | 541.66 | | | | | | | | | | | | | | | | | | | | | | | | | | | | | | | | | | | | | | | | | | | | | | | | | | |
| 0b0111 | 129 | 1075.00 | | | | | | | | | | | | | | | | | | | | | | | | | | | | | | | | | | | | | | | | | | | | | | | | | | |
| 0b1000 | 257 | 2141.66 | | | | | | | | | | | | | | | | | | | | | | | | | | | | | | | | | | | | | | | | | | | | | | | | | | |
| 0b1001 | 513 | 4275.00 | | | | | | | | | | | | | | | | | | | | | | | | | | | | | | | | | | | | | | | | | | | | | | | | | | |
| 0b1010 | 1025 | 8541.66 | | | | | | | | | | | | | | | | | | | | | | | | | | | | | | | | | | | | | | | | | | | | | | | | | | |
| 0b1011 | 2049 | 17075.00 | | | | | | | | | | | | | | | | | | | | | | | | | | | | | | | | | | | | | | | | | | | | | | | | | | |
| 0b1100 | 4097 | 34141.00 | | | | | | | | | | | | | | | | | | | | | | | | | | | | | | | | | | | | | | | | | | | | | | | | | | |
| 0b1101 | 8193 | 68275.00 | | | | | | | | | | | | | | | | | | | | | | | | | | | | | | | | | | | | | | | | | | | | | | | | | | |
| 0b1110 | 16385 | 136541.66 | | | | | | | | | | | | | | | | | | | | | | | | | | | | | | | | | | | | | | | | | | | | | | | | | | |
| 0b1111 | 32769 | 273075.00 | | | | | | | | | | | | | | | | | | | | | | | | | | | | | | | | | | | | | | | | | | | | | | | | | | |

27.6.2.3 EQADC CFIFO Push Registers (EQADC_CFPR)

The EQADC CFIFO Push Registers (EQADC_CFPR) provide a mechanism to fill the CFIFOs with command messages from the CQueues. Refer to [Section 27.7.4, EQADC Command FIFOs](#), for more information on the CFIFOs and to [Section 27.7.2.2, Message Format in EQADC](#), for a description on command message formats.

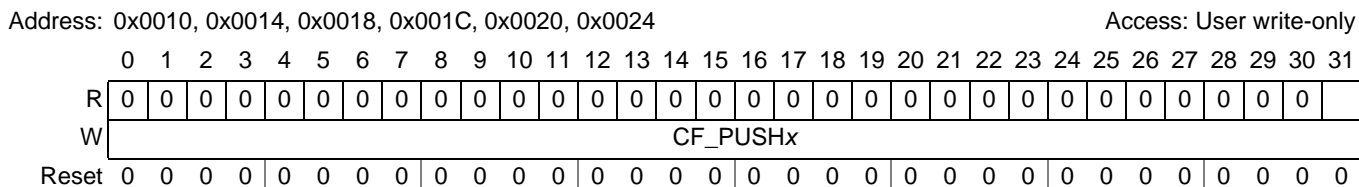

Figure 27-5. EQADC CFIFO Push Register x (EQADC_CFPRx)

Table 27-8. EQADC_CFPRx Field Description

| Field | Description |
|------------------|---|
| 0–31 CF_PUSHx | <p>CFIFO Push Data x. When CFIFOx is not full, writing to the whole word or any bytes of EQADC_CFPRx will push the 32-bit CF_PUSHx value into CFIFOx. Writing to this field also increments the corresponding EQADC_FISR[CFCTRx] value by one. When the CFIFOx is full, the EQADC ignores any write to the CF_PUSHx. Reading EQADC_CFPRx always returns zero.</p> <p>Note: Only whole words must be written to EQADC_CFPR. Writing half-words or bytes to EQADC_CFPR will still push the whole 32-bit CF_PUSH field into the corresponding CFIFO, but undefined data will fill the areas of CF_PUSH that were not specifically designated as target locations for the write.</p> |

27.6.2.4 EQADC Result FIFO Pop Registers (EQADC_RFPR)

The EQADC Result FIFO Pop Registers (EQADC_RFPR) provide a mechanism to retrieve data from RFIFOs.

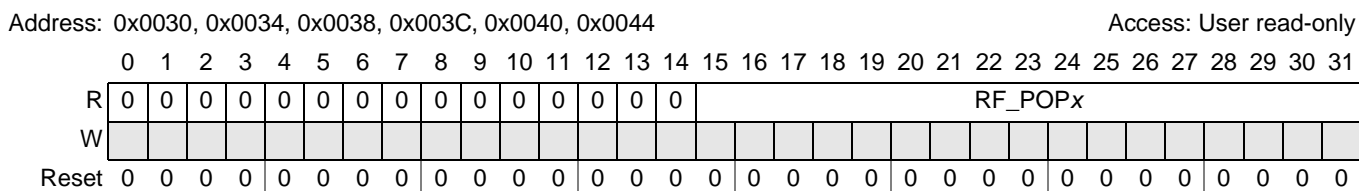

Figure 27-6. EQADC RFIFO Pop Register x (EQADC_RFPRx)

Table 27-9. EQADC_RFPRx Field Description

| Field | Description |
|------------------|---|
| 0–15 | Reserved |
| 16–31 RF_POPx | <p>Result FIFO Pop Data x. When RFIFOx is not empty, the RF_POPx contains the next unread entry value of RFIFOx. Reading a word, a half-word, or any bytes from EQADC_RFPRx will pop one entry from RFIFOx and cause the EQADC_FISR[RFCTRx] field to be decremented by one. When the RFIFOx is empty, any read on EQADC_RFPRx returns undefined data value and does not decrement the RFCTRx value. Writing to EQADC_RFPRx has no effect.</p> |

27.6.2.5 EQADC CFIFO Control Registers (EQADC_CFCR)

The EQADC CFIFO Control Registers (EQADC_CFCR) contain bits that affect CFIFOs. These bits specify the CFIFO operation mode and can invalidate all of the CFIFO contents.

Address: 0x0050 (CFIFO0) Access: User read/write
 0x0052 (CFIFO1)
 0x0054 (CFIFO2)
 0x0056 (CFIFO3)
 0x0058 (CFIFO4)
 0x005A (CFIFO5)

| | | | | | | | | | | | | | | | | |
|-------|---|---|---|------|------|------|--------|---|-------|---|----|----|---------|----|----|----|
| | 0 | 1 | 2 | 3 | 4 | 5 | 6 | 7 | 8 | 9 | 10 | 11 | 12 | 13 | 14 | 15 |
| R | 0 | 0 | 0 | CFE | STR | 0 | 0 | 0 | MODEx | | | | AMODE0* | | | |
| W | | | | EE0* | ME0* | SSEx | CFINVx | | | | | | | | | |
| Reset | 0 | 0 | 0 | 0 | 0 | 0 | 0 | 0 | 0 | 0 | 0 | 0 | 0 | 0 | 0 | 0 |

* only available for CFIFO0

Figure 27-7. EQADC CFIFO Control Register x (EQADC_CFCRx)

Table 27-10. EQADC_CFCRx Field Description

| Field | Description |
|-------------|---|
| 0–2 | Reserved |
| 3 CFEEE0 | CFIFO0 Entry Number Extension Enable. The CFEEE0 bit is used to enable the extension of the CFIFO0 entries. When in extended mode, the CFIFO0 total entries is the sum of normal entries plus the defined value for extension. For more details, refer to Section 27.7.4.2, CFIFO0 Streaming Mode Description . 1 Enable the extension of CFIFO0 entries. 0 CFIFO0 has a normal value of entries. |
| 4 STRME0 | CFIFO0 Streaming Mode Operation Enable. The STRME0 bit is used to enable the streaming mode of operation of CFIFO0. In this case, it is possible to repeat some sequence of commands of this FIFO without having to load new commands from a command queue. For more details, refer to Section 27.7.4.2, CFIFO0 Streaming Mode Description . 1 Enable the streaming mode of CFIFO0. 0 Streaming mode of CFIFO0 is disabled. |
| 5 SSEx | CFIFO Single-Scan Enable Bit x. The SSEx bit is used to set the EQADC_FISR[SSSx] bit. Writing a “1” to SSEx will set the EQADC_FISR[SSSx] field if the CFIFO is in single-scan mode. When EQADC_FISR[SSSx] is already asserted, writing a “1” to SSEx has no effect. If the CFIFO is in continuous-scan mode or is disabled, writing a “1” to SSEx will not set EQADC_FISR[SSSx]. Writing a “0” to SSEx has no effect. SSEx always is read as “0”. 0 No effect. 1 Set the SSSx bit. |
| 6 CFINVx | CFIFO Invalidate Bit x. The CFINVx bit causes the EQADC to invalidate all entries of CFIFOx. Writing a “1” to CFINVx will reset the value of EQADC_FISR[CFCTRx]. Writing a “1” to CFINVx also resets the Push Next Data Pointer, Transfer Next Data Pointer to the first entry of CFIFOx in Figure 27-49 . CFINVx always is read as “0”. Writing a “0” has no effect. 0 No effect. 1 Invalidate all of the entries in the corresponding CFIFO. Note: Writing CFINVx only invalidates commands stored in CFIFOx; previously transferred commands that are waiting for execution, that is commands stored in the CBuffers, will still be executed, and results generated by them will be stored in the appropriate RFIFO. Note: CFINVx must not be written unless the MODEx is configured to disabled, and CFIFO status is IDLE. |
| 7 | Reserved |

Table 27-10. EQADC_CFCRx Field Description (continued)

| Field | Description | | | | | | | | | | | | | | | | | | | | | | | | | | | | | | | | |
|---------------------------|---|-------------------------|----------------------|--------|----------|--------|-------------------------------|--------|---|--------|--|--------|--|--------|---|--------|--|----------------|----------|--------|-----------------------------------|--------|---|--------|--|--------|--|--------|---|--------|--|--------|----------|
| 8–11 MODE _x | <p>CFIFO Operation Mode <i>x</i>. The MODE_x field selects the CFIFO operation mode for CFIFO_x. Refer to Section 27.7.4.6, CFIFO Scan Trigger Modes, for more information on CFIFO trigger mode.</p> <p>Note: If MODE_x is not disabled, it must not be changed to any other mode besides disabled. If MODE_x is disabled and the CFIFO status is IDLE, MODE_x can be changed to any other mode.</p> <table border="1" data-bbox="472 430 1286 1161"> <thead> <tr> <th data-bbox="472 430 669 485">MODE_x[0:3]</th> <th data-bbox="669 430 1286 485">CFIFO Operation Mode</th> </tr> </thead> <tbody> <tr> <td data-bbox="472 485 669 527">0b0000</td> <td data-bbox="669 485 1286 527">Disabled</td> </tr> <tr> <td data-bbox="472 527 669 569">0b0001</td> <td data-bbox="669 527 1286 569">Software Trigger, Single Scan</td> </tr> <tr> <td data-bbox="472 569 669 611">0b0010</td> <td data-bbox="669 569 1286 611">Low Level Gated External Trigger, Single Scan</td> </tr> <tr> <td data-bbox="472 611 669 653">0b0011</td> <td data-bbox="669 611 1286 653">High Level Gated External Trigger, Single Scan</td> </tr> <tr> <td data-bbox="472 653 669 695">0b0100</td> <td data-bbox="669 653 1286 695">Falling Edge External Trigger, Single Scan</td> </tr> <tr> <td data-bbox="472 695 669 737">0b0101</td> <td data-bbox="669 695 1286 737">Rising Edge External Trigger, Single Scan</td> </tr> <tr> <td data-bbox="472 737 669 779">0b0110</td> <td data-bbox="669 737 1286 779">Falling or Rising Edge External Trigger, Single Scan</td> </tr> <tr> <td data-bbox="472 779 669 821">0b0111– 0b1000</td> <td data-bbox="669 779 1286 821">Reserved</td> </tr> <tr> <td data-bbox="472 821 669 863">0b1001</td> <td data-bbox="669 821 1286 863">Software Trigger, Continuous Scan</td> </tr> <tr> <td data-bbox="472 863 669 905">0b1010</td> <td data-bbox="669 863 1286 905">Low Level Gated External Trigger, Continuous Scan</td> </tr> <tr> <td data-bbox="472 905 669 947">0b1011</td> <td data-bbox="669 905 1286 947">High Level Gated External Trigger, Continuous Scan</td> </tr> <tr> <td data-bbox="472 947 669 989">0b1100</td> <td data-bbox="669 947 1286 989">Falling Edge External Trigger, Continuous Scan</td> </tr> <tr> <td data-bbox="472 989 669 1031">0b1101</td> <td data-bbox="669 989 1286 1031">Rising Edge External Trigger, Continuous Scan</td> </tr> <tr> <td data-bbox="472 1031 669 1073">0b1110</td> <td data-bbox="669 1031 1286 1073">Falling or Rising Edge External Trigger, Continuous Scan</td> </tr> <tr> <td data-bbox="472 1073 669 1115">0b1111</td> <td data-bbox="669 1073 1286 1115">Reserved</td> </tr> </tbody> </table> | MODE _x [0:3] | CFIFO Operation Mode | 0b0000 | Disabled | 0b0001 | Software Trigger, Single Scan | 0b0010 | Low Level Gated External Trigger, Single Scan | 0b0011 | High Level Gated External Trigger, Single Scan | 0b0100 | Falling Edge External Trigger, Single Scan | 0b0101 | Rising Edge External Trigger, Single Scan | 0b0110 | Falling or Rising Edge External Trigger, Single Scan | 0b0111– 0b1000 | Reserved | 0b1001 | Software Trigger, Continuous Scan | 0b1010 | Low Level Gated External Trigger, Continuous Scan | 0b1011 | High Level Gated External Trigger, Continuous Scan | 0b1100 | Falling Edge External Trigger, Continuous Scan | 0b1101 | Rising Edge External Trigger, Continuous Scan | 0b1110 | Falling or Rising Edge External Trigger, Continuous Scan | 0b1111 | Reserved |
| MODE _x [0:3] | CFIFO Operation Mode | | | | | | | | | | | | | | | | | | | | | | | | | | | | | | | | |
| 0b0000 | Disabled | | | | | | | | | | | | | | | | | | | | | | | | | | | | | | | | |
| 0b0001 | Software Trigger, Single Scan | | | | | | | | | | | | | | | | | | | | | | | | | | | | | | | | |
| 0b0010 | Low Level Gated External Trigger, Single Scan | | | | | | | | | | | | | | | | | | | | | | | | | | | | | | | | |
| 0b0011 | High Level Gated External Trigger, Single Scan | | | | | | | | | | | | | | | | | | | | | | | | | | | | | | | | |
| 0b0100 | Falling Edge External Trigger, Single Scan | | | | | | | | | | | | | | | | | | | | | | | | | | | | | | | | |
| 0b0101 | Rising Edge External Trigger, Single Scan | | | | | | | | | | | | | | | | | | | | | | | | | | | | | | | | |
| 0b0110 | Falling or Rising Edge External Trigger, Single Scan | | | | | | | | | | | | | | | | | | | | | | | | | | | | | | | | |
| 0b0111– 0b1000 | Reserved | | | | | | | | | | | | | | | | | | | | | | | | | | | | | | | | |
| 0b1001 | Software Trigger, Continuous Scan | | | | | | | | | | | | | | | | | | | | | | | | | | | | | | | | |
| 0b1010 | Low Level Gated External Trigger, Continuous Scan | | | | | | | | | | | | | | | | | | | | | | | | | | | | | | | | |
| 0b1011 | High Level Gated External Trigger, Continuous Scan | | | | | | | | | | | | | | | | | | | | | | | | | | | | | | | | |
| 0b1100 | Falling Edge External Trigger, Continuous Scan | | | | | | | | | | | | | | | | | | | | | | | | | | | | | | | | |
| 0b1101 | Rising Edge External Trigger, Continuous Scan | | | | | | | | | | | | | | | | | | | | | | | | | | | | | | | | |
| 0b1110 | Falling or Rising Edge External Trigger, Continuous Scan | | | | | | | | | | | | | | | | | | | | | | | | | | | | | | | | |
| 0b1111 | Reserved | | | | | | | | | | | | | | | | | | | | | | | | | | | | | | | | |

Table 27-10. EQADC_CFCRx Field Description (continued)

| Field | Description | | | | | | | | | | | | | | | | | | |
|-----------------|---|-------------|---------------------------------------|--------|----------|--------|-------------------------------|--------|---|--------|--|--------|--|--------|---|--------|--|---------------|----------|
| 12–15 AMODE0 | <p>CFIFO0 Advance Trigger Operation Mode 0. The AMODE0 field selects the trigger mode for the ATRIG0 trigger signal in streaming mode. The use of reserved values drives to unknown behavior of the block.</p> <p>Note: If AMODE0 is not disabled, it must not be changed to any other mode besides disabled. If AMODE0 is disabled and the CFIFO0 status is IDLE, AMODE0 can be changed to any other mode.</p> <p>Note: For the streaming mode of operation when the ATRIG0 is used to enable the ETRIG0 or to advance the command queue, the normal mode of operation is external trigger single scan. Other settings are not fully tested.</p> <table border="1" style="margin-left: auto; margin-right: auto;"> <thead> <tr> <th>AMODE0[0:3]</th> <th>CFIFO0 Advance Trigger Operation Mode</th> </tr> </thead> <tbody> <tr> <td>0b0000</td> <td>Disabled</td> </tr> <tr> <td>0b0001</td> <td>Software Trigger, Single Scan</td> </tr> <tr> <td>0b0010</td> <td>Low Level Gated External Trigger, Single Scan</td> </tr> <tr> <td>0b0011</td> <td>High Level Gated External Trigger, Single Scan</td> </tr> <tr> <td>0b0100</td> <td>Falling Edge External Trigger, Single Scan</td> </tr> <tr> <td>0b0101</td> <td>Rising Edge External Trigger, Single Scan</td> </tr> <tr> <td>0b0110</td> <td>Falling or Rising Edge External Trigger, Single Scan</td> </tr> <tr> <td>0b0111–0b1111</td> <td>Reserved</td> </tr> </tbody> </table> | AMODE0[0:3] | CFIFO0 Advance Trigger Operation Mode | 0b0000 | Disabled | 0b0001 | Software Trigger, Single Scan | 0b0010 | Low Level Gated External Trigger, Single Scan | 0b0011 | High Level Gated External Trigger, Single Scan | 0b0100 | Falling Edge External Trigger, Single Scan | 0b0101 | Rising Edge External Trigger, Single Scan | 0b0110 | Falling or Rising Edge External Trigger, Single Scan | 0b0111–0b1111 | Reserved |
| AMODE0[0:3] | CFIFO0 Advance Trigger Operation Mode | | | | | | | | | | | | | | | | | | |
| 0b0000 | Disabled | | | | | | | | | | | | | | | | | | |
| 0b0001 | Software Trigger, Single Scan | | | | | | | | | | | | | | | | | | |
| 0b0010 | Low Level Gated External Trigger, Single Scan | | | | | | | | | | | | | | | | | | |
| 0b0011 | High Level Gated External Trigger, Single Scan | | | | | | | | | | | | | | | | | | |
| 0b0100 | Falling Edge External Trigger, Single Scan | | | | | | | | | | | | | | | | | | |
| 0b0101 | Rising Edge External Trigger, Single Scan | | | | | | | | | | | | | | | | | | |
| 0b0110 | Falling or Rising Edge External Trigger, Single Scan | | | | | | | | | | | | | | | | | | |
| 0b0111–0b1111 | Reserved | | | | | | | | | | | | | | | | | | |

27.6.2.6 EQADC Interrupt and DMA Control Registers (EQADC_IDCR)

The EQADC Interrupt Control Registers (EQADC_IDCR) contain bits to enable the generation of interrupt or DMA requests when the corresponding flag bits are set in [Section 27.6.2.7, EQADC FIFO and Interrupt Status Registers \(EQADC_FISR\)](#).

Address: 0x0060

Access: User read/write

| | 0 | 1 | 2 | 3 | 4 | 5 | 6 | 7 | 8 | 9 | 10 | 11 | 12 | 13 | 14 | 15 |
|-------|-------|--------|------|--------|--------|----|-------|-------|----|----|----|----|--------|----|-------|-------|
| R | NCIE0 | TORIE0 | PIE0 | EOQIE0 | CFUIE0 | 0 | CFFE0 | CFFS0 | 0 | 0 | 0 | 0 | RFOIE0 | 0 | RFDE0 | RFDS0 |
| W | | | | | | | | | | | | | | | | |
| Reset | 0 | 0 | 0 | 0 | 0 | 0 | 0 | 0 | 0 | 0 | 0 | 0 | 0 | 0 | 0 | 0 |
| | 16 | 17 | 18 | 19 | 20 | 21 | 22 | 23 | 24 | 25 | 26 | 27 | 28 | 29 | 30 | 31 |
| R | NCIE1 | TORIE1 | PIE1 | EOQIE1 | CFUIE1 | 0 | CFFE1 | CFFS1 | 0 | 0 | 0 | 0 | RFOIE1 | 0 | RFDE1 | RFDS1 |
| W | | | | | | | | | | | | | | | | |
| Reset | 0 | 0 | 0 | 0 | 0 | 0 | 0 | 0 | 0 | 0 | 0 | 0 | 0 | 0 | 0 | 0 |

Figure 27-8. EQADC Interrupt and DMA Control Register 0 (EQADC_IDCR0)

Address: 0x0064 Access: User read/write

| | | | | | | | | | | | | | | | | |
|-------|-------|--------|------|--------|--------|---|-------|-------|---|---|----|----|--------|----|-------|-------|
| | 0 | 1 | 2 | 3 | 4 | 5 | 6 | 7 | 8 | 9 | 10 | 11 | 12 | 13 | 14 | 15 |
| R | NCIE2 | TORIE2 | PIE2 | EOQIE2 | CFUIE2 | 0 | CFFE2 | CFFS2 | 0 | 0 | 0 | 0 | RFOIE2 | 0 | RFDE2 | RFDS2 |
| W | | | | | | | | | | | | | | | | |
| Reset | 0 | 0 | 0 | 0 | 0 | 0 | 0 | 0 | 0 | 0 | 0 | 0 | 0 | 0 | 0 | 0 |

| | | | | | | | | | | | | | | | | |
|-------|-------|--------|------|--------|--------|----|-------|-------|----|----|----|----|--------|----|-------|-------|
| | 16 | 17 | 18 | 19 | 20 | 21 | 22 | 23 | 24 | 25 | 26 | 27 | 28 | 29 | 30 | 31 |
| R | NCIE3 | TORIE3 | PIE3 | EOQIE3 | CFUIE3 | 0 | CFFE3 | CFFS3 | 0 | 0 | 0 | 0 | RFOIE3 | 0 | RFDE3 | RFDS3 |
| W | | | | | | | | | | | | | | | | |
| Reset | 0 | 0 | 0 | 0 | 0 | 0 | 0 | 0 | 0 | 0 | 0 | 0 | 0 | 0 | 0 | 0 |

Figure 27-9. EQADC Interrupt and DMA Control Register 1 (EQADC_IDCR1)

Address: 0x0068 Access: User read/write

| | | | | | | | | | | | | | | | | |
|-------|-------|--------|------|--------|--------|---|-------|-------|---|---|----|----|--------|----|-------|-------|
| | 0 | 1 | 2 | 3 | 4 | 5 | 6 | 7 | 8 | 9 | 10 | 11 | 12 | 13 | 14 | 15 |
| R | NCIE4 | TORIE4 | PIE4 | EOQIE4 | CFUIE4 | 0 | CFFE4 | CFFS4 | 0 | 0 | 0 | 0 | RFOIE4 | 0 | RFDE4 | RFDS4 |
| W | | | | | | | | | | | | | | | | |
| Reset | 0 | 0 | 0 | 0 | 0 | 0 | 0 | 0 | 0 | 0 | 0 | 0 | 0 | 0 | 0 | 0 |

| | | | | | | | | | | | | | | | | |
|-------|-------|--------|------|--------|--------|----|-------|-------|----|----|----|----|--------|----|-------|-------|
| | 16 | 17 | 18 | 19 | 20 | 21 | 22 | 23 | 24 | 25 | 26 | 27 | 28 | 29 | 30 | 31 |
| R | NCIE5 | TORIE5 | PIE5 | EOQIE5 | CFUIE5 | 0 | CFFE5 | CFFS5 | 0 | 0 | 0 | 0 | RFOIE5 | 0 | RFDE5 | RFDS5 |
| W | | | | | | | | | | | | | | | | |
| Reset | 0 | 0 | 0 | 0 | 0 | 0 | 0 | 0 | 0 | 0 | 0 | 0 | 0 | 0 | 0 | 0 |

Figure 27-10. EQADC Interrupt and DMA Control Register 2 (EQADC_IDCR2)

Table 27-11. EQADC_IDCR Field Description

| Field | Description |
|-------------------------------|---|
| 0 16 NCIE _x | Non-Coherency Interrupt Enable x. NCIE _x enables the EQADC to generate an interrupt request when the corresponding EQADC_FISR[NCF _x] is asserted. 0 Disable non-coherency interrupt request. 1 Enable non-coherency interrupt request. |
| 1 17 TORIE _x | Trigger Overrun Interrupt Enable x. TORIE _x enables the EQADC to generate an interrupt request when the corresponding EQADC_FISR[TORF _x] is asserted. Apart from generating an independent interrupt request for a CFIFO _x Trigger Overrun event, the EQADC also provides a combined interrupt at which the Result FIFO Overflow Interrupt, the Command FIFO Underflow Interrupt, and the Command FIFO Trigger Overrun Interrupt requests of ALL CFIFOs are ORed. When RFOIE _x , CFUIE _x , and TORIE _x are all asserted, this combined interrupt request is asserted whenever one of the following 18 flags becomes asserted: RFOF _x , CFUF _x , and TORF _x (assuming that all interrupts are enabled). See Section 27.7.8, EQADC DMA/Interrupt Request , for details. 0 Disable trigger overrun interrupt request. 1 Enable trigger overrun interrupt request. |
| 2 18 PIE _x | Pause Interrupt Enable x. PIE _x enables the EQADC to generate an interrupt request when the corresponding EQADC_FISR[PF _x] is asserted. 1 Enable pause interrupt request. 0 Disable pause interrupt request. |

Table 27-11. EQADC_IDCR Field Description (continued)

| Field | Description |
|--------------------------------|---|
| 3 19 EOQIE _x | <p>End of Queue Interrupt Enable <i>x</i>. EOQIE_x enables the EQADC to generate an interrupt request when the corresponding EQADC_FISR[EOQF_x] is asserted.</p> <p>0 Disable End of Queue interrupt request. 1 Enable End of Queue interrupt request.</p> |
| 4 20 CFUIE _x | <p>CFIFO Underflow Interrupt Enable <i>x</i>. CFUIE_x enables the EQADC to generate an interrupt request when the corresponding EQADC_FISR[CFUF_x] is asserted.</p> <p>Apart from generating an independent interrupt request for a CFIFO_x underflow event, the EQADC also provides a combined interrupt at which the Result FIFO Overflow Interrupt, the Command FIFO Underflow Interrupt, and the Command FIFO Trigger Overrun Interrupt requests of all CFIFOs are ORed. When RFOIE_x, CFUIE_x, and TORIE_x are all asserted, this combined interrupt request is asserted whenever one of the following 18 flags becomes asserted: RFOF_x, CFUF_x, and TORF_x (assuming that all interrupts are enabled). See Section 27.7.8, EQADC DMA/Interrupt Request, for details.</p> <p>0 Disable Underflow Interrupt request. 1 Enable Underflow Interrupt request.</p> |
| 5 21 | Reserved |
| 6 22 CFFEx | <p>CFIFO Fill Enable <i>x</i>. CFFEx enables the EQADC to generate an interrupt request (CFFS_x is asserted) or DMA request (CFFS_x is negated) when EQADC_FISR[CFFF_x] is asserted.</p> <p>0 Disable CFIFO Fill DMA or Interrupt request. 1 Enable CFIFO Fill DMA or Interrupt request.</p> <p>Note: CFFEx must not be negated while a DMA transaction is in progress.</p> |
| 7 23 CFFS _x | <p>CFIFO Fill Select <i>x</i>. CFFS_x selects if a DMA or interrupt request is generated when EQADC_FISR[CFFF_x] is asserted. If CFFEx is asserted, the EQADC generates an interrupt request when CFFS_x is negated, or it generates a DMA request if CFFS_x is asserted.</p> <p>0 Generate interrupt request to move data from the system memory to CFIFO_x. 1 Generate DMA request to move data from the system memory to CFIFO_x.</p> <p>Note: CFFS_x must not be negated while a DMA transaction is in progress.</p> |
| 8–11 24–27 | Reserved |
| 12 28 RFOIE _x | <p>RFIFO Overflow Interrupt Enable <i>x</i>. RFOIE_x enables the EQADC to generate an interrupt request when the corresponding EQADC_FISR[RFOF_x] is asserted.</p> <p>Apart from generating an independent interrupt request for an RFIFO_x overflow event, the EQADC also provides a combined interrupt at which the Result FIFO Overflow Interrupt, the Command FIFO Underflow Interrupt, and the Command FIFO Trigger Overrun Interrupt requests of ALL CFIFOs are ORed. When RFOIE_x, CFUIE_x, and TORIE_x are all asserted, this combined interrupt request is asserted whenever one of the following 18 flags becomes asserted: RFOF_x, CFUF_x, and TORF_x (assuming that all interrupts are enabled). See Section 27.7.8, EQADC DMA/Interrupt Request, for details.</p> <p>0 Disable Overflow Interrupt request. 1 Enable Overflow Interrupt request.</p> |
| 13 29 | Reserved |

Table 27-11. EQADC_IDCR Field Description (continued)

| Field | Description |
|-------------------|--|
| 14 30 RFDEx | <p>RFIFO Drain Enable x. RFDEx enables the EQADC to generate an interrupt request (RFDSx is asserted) or DMA request (RFDSx is negated) when EQADC_FISR[RFDFx] is asserted.</p> <p>0 Disable RFIFO Drain DMA or Interrupt request. 1 Enable RFIFO Drain DMA or Interrupt request.</p> <p>Note: RFDEx must not be negated while a DMA transaction is in progress.</p> |
| 14 31 RFDSx | <p>RFIFO Drain Select x. RFDSx selects if a DMA or interrupt request is generated when EQADC_FISR[RFDFx] is asserted. If RFDEx is asserted, the EQADC generates an interrupt request when RFDSx is negated, or it generates a DMA request when RFDSx is asserted.</p> <p>0 Generate interrupt request to move data from RFIFOx to the system memory. 1 Generate DMA request to move data from RFIFOx to the system memory.</p> <p>Note: RFDSx must not be negated while a DMA transaction is in progress.</p> |

27.6.2.7 EQADC FIFO and Interrupt Status Registers (EQADC_FISR)

The EQADC FIFO and Interrupt Status Registers (EQADC_FISR) contain flag and status bits for each CFIFO and RFIFO pair. Write “1” to a flag bit to clear it. Writing “0” has no effect. Status bits are read only. These bits indicate the status of the FIFO itself.

Address: 0x0070, 0x0074, 0x0078, 0x007C, 0x0080, 0x0084

Access: User read/write

| | | | | | | | | | | | | | | | | |
|-------|--------|-------|-----|-------|----------|------|-------|----|--------|----|----|----|------------|----|-------|----|
| | 0 | 1 | 2 | 3 | 4 | 5 | 6 | 7 | 8 | 9 | 10 | 11 | 12 | 13 | 14 | 15 |
| R | | | | | | SSSx | | 0 | 0 | 0 | 0 | 0 | | 0 | | 0 |
| W | NCFx | TORFx | PFx | EOQFx | CFUFx | | CFFFx | | | | | | RFOFx | | RFDFx | |
| Reset | 0 | 0 | 0 | 0 | 0 | 0 | 1 | 0 | 0 | 0 | 0 | 0 | 0 | 0 | 0 | 0 |
| | 16 | 17 | 18 | 19 | 20 | 21 | 22 | 23 | 24 | 25 | 26 | 27 | 28 | 29 | 30 | 31 |
| R | CFCTRx | | | | TNXTPTRx | | | | RFCTRx | | | | POPNXTPTRx | | | |
| W | | | | | | | | | | | | | | | | |
| Reset | 0 | 0 | 0 | 0 | 0 | 0 | 0 | 0 | 0 | 0 | 0 | 0 | 0 | 0 | 0 | 0 |

Figure 27-11. EQADC FIFO and Interrupt Status Register x (EQADC_FISRx)

Table 27-12. EQADC_FISR_x Field Description

| Field | Description |
|-------------------------------|--|
| <p>0 NCF_x</p> | <p>Non-Coherency Flag. NCF_x is set whenever a command sequence being transferred through CFIFO_x becomes non coherent. If EQADC_IDCR[NCFIE_x] and NCF_x are asserted, an interrupt request will be generated. Write “1” to clear NCF_x. Writing a “0” has no effect. For more information refer to Section 27.7.4.7.5, Command Sequence Non-Coherency Detection.</p> <p>0 Command sequence being transferred by CFIFO_x is coherent. 1 Command sequence being transferred by CFIFO_x became non-coherent.</p> |
| <p>1 TORF_x</p> | <p>Trigger Overrun Flag for CFIFO_x. TORF_x is set when trigger overrun occurs for the specified CFIFO in edge or level trigger mode. Trigger overrun occurs when an already triggered CFIFO receives an additional trigger. When EQADC_IDCR[TORIE_x] and TORF_x are asserted, an interrupt request will be generated.</p> <p>Apart from generating an independent interrupt request for a CFIFO_x Trigger Overrun event, the EQADC also provides a combined interrupt at which the Result FIFO Overflow Interrupt, the Command FIFO Underflow Interrupt, and the Command FIFO Trigger Overrun Interrupt requests of ALL CFIFOs are ORed. When RFOIE_x, CFUIE_x, and TORIE_x are all asserted, this combined interrupt request is asserted whenever one of the following 18 flags becomes asserted: RFOF_x, CFUF_x, and TORF_x (assuming that all interrupts are enabled). See Section 27.7.8, EQADC DMA/Interrupt Request, for details.</p> <p>Write “1” to clear the TORF_x bit. Writing a “0” has no effect.</p> <p>0 No trigger overrun occurred. 1 Trigger overrun occurred.</p> <p>Note: The trigger overrun flag will not set for CFIFOs configured for software trigger mode.</p> |
| <p>2 PF_x</p> | <p>Pause Flag x. PF behavior changes according to the CFIFO trigger mode. In edge trigger mode, PF_x is set when the EQADC completes the transfer of an entry with an asserted Pause bit from CFIFO_x. In level trigger mode, when CFIFO_x is in TRIGGERED status, PF_x is set when CFIFO status changes from TRIGGERED due to the detection of a closed gate. An interrupt routine, generated due to the asserted PF, can be used to verify if a complete scan of the CQueue was performed. If a closed gate is detected while no command transfers are taking place, it will have immediate effect on the CFIFO status. If a closed gate is detected while a command transfer to an on-chip CBuffer is taking place, it will only affect the CFIFO status when the transfer completes. The transfer of entries bound for the on-chip ADCs is considered completed when they are stored in the appropriate CBuffer.</p> <p>If EQADC_IDCR[PIE_x] and PF_x are asserted, an interrupt will be generated. Write “1” to clear the PF_x. Writing a “0” has no effect. Refer to Section 27.7.4.7.3, Pause Status, for more information on the Pause Flag.</p> <p>0 Entry with asserted PAUSE bit was not transferred from CFIFO_x (CFIFO in edge trigger mode), or CFIFO status did not change from TRIGGERED due to detection of a closed gate (CFIFO in level trigger mode). 1 Entry with asserted PAUSE bit was transferred from CFIFO_x (CFIFO in edge trigger mode), or CFIFO status changes from TRIGGERED due to detection of a closed gate (CFIFO in level trigger mode).</p> <p>Note: In edge trigger mode, an asserted PF_x only implies that the EQADC has finished transferring a command with an asserted PAUSE bit from CFIFO_x. It does not imply that result data for the current command and for all previously transferred commands has been returned to the appropriate RFIFO.</p> <p>Note: In software or level trigger mode, when the EQADC completes the transfer of an entry from CFIFO_x with an asserted PAUSE bit, PF_x will not be set and transfer of commands will continue without pausing.</p> |

Table 27-12. EQADC_FISR_x Field Description (continued)

| Field | Description |
|------------------------|--|
| 3 EOQF _x | <p>End of Queue Flag x. EOQF_x indicates that an entry with an asserted EOQ bit was transferred from CFIFO_x to the on-chip ADCs - see Section 27.7.2.2, Message Format in EQADC, for details about command message formats. When the EQADC completes the transfer of an entry with an asserted EOQ bit from CFIFO_x, EOQF_x will be set. The transfer of entries bound for the on-chip ADCs is considered completed when they are stored in the appropriate CBuffer. If the EQADC_IDCR[EOQIE_x] and EOQF_x are asserted, an interrupt will be generated.</p> <p>Write “1” to clear the EOQF_x bit. Writing a “0” has no effect. Refer to Section 27.7.4.7.2, CQueue Completion Status, for more information on the End of Queue Flag.</p> <p>1 Entry with asserted EOQ bit was transferred from CFIFO_x. 0 Entry with asserted EOQ bit was not transferred from CFIFO_x.</p> <p>Note: An asserted EOQF_x only implies that the EQADC has finished transferring a command with an asserted EOQ bit from CFIFO_x. It does not imply that result data for the current command and for all previously transferred commands has been returned to the appropriate RFIFO.</p> |
| 4 CFUF _x | <p>CFIFO Underflow Flag x. CFUF_x indicates an underflow event on CFIFO_x. CFUF_x is set when CFIFO_x is in TRIGGERED state and it becomes empty. No commands will be transferred from an underflowing CFIFO, nor will command transfers from lower priority CFIFOs be blocked. When EQADC_IDCR[CFUIE_x] and CFUF_x are both asserted, the EQADC generates an interrupt request.</p> <p>Apart from generating an independent interrupt request for a CFIFO_x underflow event, the EQADC also provides a combined interrupt at which the Result FIFO Overflow Interrupt, the Command FIFO Underflow Interrupt, and the Command FIFO Trigger Overrun Interrupt requests of ALL CFIFOs are ORed. When RFOIE_x, CFUIE_x, and TORIE_x are all asserted, this combined interrupt request is asserted whenever one of the following 18 flags becomes asserted: RFOF_x, CFUF_x, and TORF_x (assuming that all interrupts are enabled). See Section 27.7.8, EQADC DMA/Interrupt Request, for details.</p> <p>Write “1” to clear CFUF_x. Writing a “0” has no effect.</p> <p>0 No CFIFO underflow event occurred. 1 A CFIFO underflow event occurred.</p> |
| 5 SSS _x | <p>CFIFO Single-Scan Status Bit x. An asserted SSS_x bit enables the detection of trigger events for CFIFOs programmed into single-scan level- or edge-trigger mode, and works as trigger for CFIFOs programmed into single-scan software-trigger mode. Refer to Section 27.7.4.6.2, Single-Scan Mode, for further details. The SSS_x bit is set by writing a “1” to EQADC_CFCR[SSE_x]. The EQADC clears the SSS_x bit when a command with an asserted EOQ bit is transferred from a CFIFO in single-scan mode, when a CFIFO is in single-scan level-trigger mode and its status changes from TRIGGERED due to the detection of a closed gate, or when the value of the CFIFO operation mode (EQADC_CFCR[MODE_x]) is changed to disabled. Writing to SSS_x has no effect. SSS_x has no effect in continuous-scan or in disabled mode.</p> <p>0 CFIFO in single-scan level- or edge-trigger mode will ignore trigger events, or CFIFO in single-scan software-trigger mode is not triggered. 1 CFIFO in single-scan level- or edge-trigger mode will detect a trigger event, or CFIFO in single-scan software-trigger mode is triggered.</p> |

Table 27-12. EQADC_FISR_x Field Description (continued)

| Field | Description |
|-----------------------------|--|
| 6 CFFF _x | <p>CFIFO Fill Flag x. CFFF_x is set when the CFIFO_x is not full. When EQADC_IDCR[CFFE_x] and CFFF_x are both asserted, an interrupt or a DMA request will be generated depending on the status of the CFFS_x bit. When CFFS_x is negated (interrupt requests selected), software clears CFFF_x by writing a “1” to it. Writing a “0” has no effect. When CFFS_x is asserted (DMA requests selected), CFFF_x is automatically cleared by the EQADC when the CFIFO becomes full.</p> <p>0 CFIFO_x is full. 1 CFIFO_x is not full.</p> <p>Note: Writing “1” to CFFF_x when CFFS_x is asserted (DMA requests selected) is not allowed. Note: When generation of interrupt requests is selected (CFFS_x=0), CFFF_x must only be cleared in the ISR after the CFIFO_x push register is accessed.</p> |
| 7–11 | Reserved |
| 12 RFOF _x | <p>RFIFO Overflow Flag x. RFOF_x indicates an overflow event on RFIFO_x. RFOF_x is set when RFIFO_x is already full, and a new data is received from the on-chip ADCs. The RFIFO_x will not overwrite older data in the RFIFO, and the new data will be ignored. When EQADC_IDCR[RFOIE_x] and RFOF_x are both asserted, the EQADC generates an interrupt request.</p> <p>Apart from generating an independent interrupt request for an RFIFO_x overflow event, the EQADC also provides a combined interrupt at which the Result FIFO Overflow Interrupt, the Command FIFO Underflow Interrupt, and the Command FIFO Trigger Overrun Interrupt requests of ALL CFIFOs are ORed. When RFOIE_x, CFUIE_x, and TORIE_x are all asserted, this combined interrupt request is asserted whenever one of the following 18 flags becomes asserted: RFOF_x, CFUF_x, and TORF_x (assuming that all interrupts are enabled). See Section 27.7.8, EQADC DMA/Interrupt Request, for details.</p> <p>Write “1” to clear RFOF_x. Writing a “0” has no effect.</p> <p>0 No RFIFO overflow event occurred. 1 An RFIFO overflow event occurred.</p> |
| 13 | Reserved |
| 14 RFDF _x | <p>RFIFO Drain Flag x. RFDF_x indicates if RFIFO_x has valid entries or not. RFDF_x is set when the RFIFO_x has at least one valid entry in it. When EQADC_IDCR[RFDE_x] and RFDF_x are both asserted, an interrupt or a DMA request will be generated depending on the status of the RFDS_x bit. When RFDS_x is negated (interrupt requests selected), software clears RFDF_x by writing a “1” to it. Writing a “0” has no effect. When RFDS_x is asserted (DMA requests selected), RFDF_x is automatically cleared by the EQADC when the RFIFO becomes empty.</p> <p>0 RFIFO_x is empty. 1 RFIFO_x has at least one valid entry.</p> <p>Note: Writing “1” to RFDF_x when RFDS_x is asserted (DMA requests selected) is not allowed. Note: When the generation of interrupt requests is selected (RFDS_x=0), RFDF_x must only be cleared in the ISR after the RFIFO_x pop register is accessed.</p> |
| 15 | Reserved |
| 16–19 CFCTR _x | <p>CFIFO_x Entry Counter. CFCTR_x indicates the number of commands stored in the CFIFO_x. When the EQADC completes transferring a piece of new data from the CFIFO_x, it decrements CFCTR_x by one. Writing a word or any bytes to the corresponding EQADC_CFPR increments CFCTR_x by one. Writing any value to CFCTR_x has no effect.</p> |

Table 27-12. EQADC_FISR_x Field Description (continued)

| Field | Description |
|------------------------------------|--|
| 20–23 TNXTPTR _x | CFIFO _x Transfer Next Pointer. TNXTPTR _x indicates the index of the next entry to be removed from CFIFO _x when it completes a transfer. When TNXTPTR _x is zero, it points to the entry with the smallest memory-mapped address inside CFIFO _x . TNXTPTR _x is only updated when a command transfer is completed. If the maximum index number (CFIFO depth minus one) is reached, TNXTPTR _x is wrapped to zero, else, it is incremented by one. For details refer to Section 27.7.4.1, CFIFO Basic Functionality . Writing any value to TNXTPTR _x has no effect. |
| 24–27 RFCTR _x | RFIFO _x Entry Counter. RFCTR _x indicates the number of data items stored in the RFIFO _x . When the EQADC stores a piece of new data into RFIFO _x , it increments RFCTR _x by one. Reading the whole word, half-word or any bytes of the corresponding EQADC_RFPR decrements RFCTR _x by one. Writing any value to RFCTR _x itself has no effect. |
| 28–31 POPNT PTR _x | RFIFO _x Pop Next Pointer. POPNTPTR _x indicates the index of the entry that will be returned when EQADC_RFPR _x is read. When POPNTPTR _x is zero, it points to the entry with the smallest memory-mapped address inside RFIFO _x . POPNTPTR _x is updated when EQADC_RFPR _x is read. If the maximum index number (RFIFO depth minus one) is reached, POPNTPTR _x is wrapped to zero, else, it is incremented by one. For details refer to Section 27.7.5.1, RFIFO Basic Functionality . Writing any value to POPNTPTR _x has no effect. |

27.6.2.8 EQADC CFIFO Transfer Counter Registers (EQADC_CFTCR)

The EQADC CFIFO Transfer Counter Registers (EQADC_CFTCR) record the number of commands transferred from a CFIFO. The EQADC_CFTCR supports the monitoring of command transfers from a CFIFO.

Address: 0x0090 Access: User read/write

| | | | | | | | | | | | | | | | | | |
|-------|----|----|----|----|----|--------|----|----|----|----|----|----|----|----|----|----|--|
| | 0 | 1 | 2 | 3 | 4 | 5 | 6 | 7 | 8 | 9 | 10 | 11 | 12 | 13 | 14 | 15 | |
| R | 0 | 0 | 0 | 0 | 0 | TC_CF0 | | | | | | | | | | | |
| W | | | | | | | | | | | | | | | | | |
| Reset | 0 | 0 | 0 | 0 | 0 | 0 | 0 | 0 | 0 | 0 | 0 | 0 | 0 | 0 | 0 | 0 | |
| | 16 | 17 | 18 | 19 | 20 | 21 | 22 | 23 | 24 | 25 | 26 | 27 | 28 | 29 | 30 | 31 | |
| R | 0 | 0 | 0 | 0 | 0 | TC_CF1 | | | | | | | | | | | |
| W | | | | | | | | | | | | | | | | | |
| Reset | 0 | 0 | 0 | 0 | 0 | 0 | 0 | 0 | 0 | 0 | 0 | 0 | 0 | 0 | 0 | 0 | |

Figure 27-12. EQADC CFIFO Transfer Counter Register 0 (EQADC_CFTCR0)

Address: 0x0094 Access: User read/write

| | | | | | | | | | | | | | | | | | |
|-------|----|----|----|----|----|--------|----|----|----|----|----|----|----|----|----|----|--|
| | 0 | 1 | 2 | 3 | 4 | 5 | 6 | 7 | 8 | 9 | 10 | 11 | 12 | 13 | 14 | 15 | |
| R | 0 | 0 | 0 | 0 | 0 | TC_CF2 | | | | | | | | | | | |
| W | | | | | | | | | | | | | | | | | |
| Reset | 0 | 0 | 0 | 0 | 0 | 0 | 0 | 0 | 0 | 0 | 0 | 0 | 0 | 0 | 0 | 0 | |
| | 16 | 17 | 18 | 19 | 20 | 21 | 22 | 23 | 24 | 25 | 26 | 27 | 28 | 29 | 30 | 31 | |
| R | 0 | 0 | 0 | 0 | 0 | TC_CF3 | | | | | | | | | | | |
| W | | | | | | | | | | | | | | | | | |
| Reset | 0 | 0 | 0 | 0 | 0 | 0 | 0 | 0 | 0 | 0 | 0 | 0 | 0 | 0 | 0 | 0 | |

Figure 27-13. EQADC CFIFO Transfer Counter Register 1 (EQADC_CFTCR1)

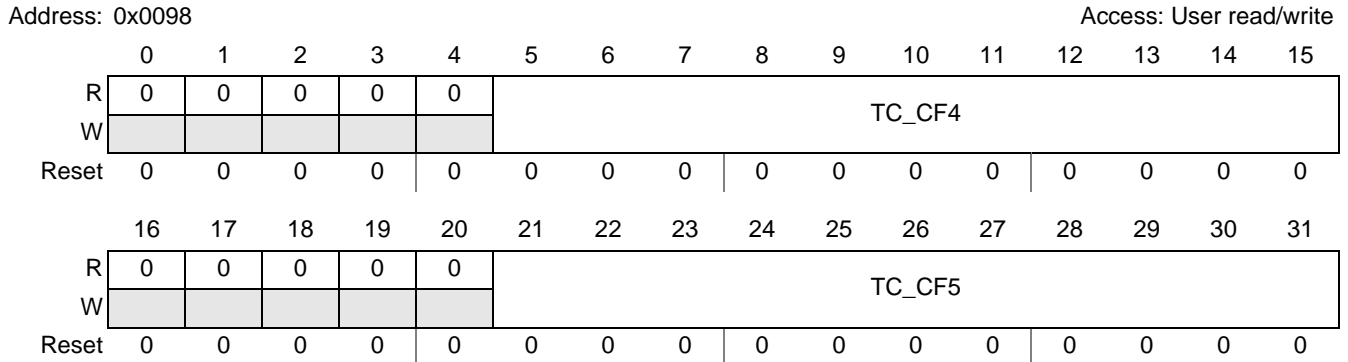

Figure 27-14. EQADC CFIFO Transfer Counter Register 2 (EQADC_CFTCR2)

Table 27-13. EQADC_CFTCRx Field Descriptions

| Field | Description |
|-------------------------|---|
| 0–4 16–20 | Reserved |
| 5–15 21–31 TC_CFx | <p>Transfer Counter for CFIFOx. TC_CFx counts the number of commands which have been completely transferred from CFIFOx. The transfer of entries bound for the on-chip ADCs is considered completed when they are stored in the appropriate CBuffer. The EQADC increments the TC_CFx value by one after a command is transferred. TC_CFx resets to zero after EQADC completes transferring a command with an asserted EOQ bit. Writing any value to TC_CFx sets the counter to that written value.</p> <p>Note: If CFIFOx is in TRIGGERED state when its MODEx field is programmed to disabled, the exact number of entries transferred from the CFIFO until that point - TC_CFx - is only known after the CFIFO status changes to IDLE, as indicated by CFSx. For details refer to Section 27.7.4.6.1, Disabled Mode.</p> |

27.6.2.9 EQADC CFIFO Status Snapshot Registers (EQADC_CFSSR)

The EQADC CFIFO Status Snapshot Registers (EQADC_CFSSR) contain status fields to track the operation status of each CFIFO and the transfer counter of the last CFIFO to initiate a command transfer to the internal CBuffers. EQADC_CFSSR0-1 are related to the on-chip CBuffers (CBuffer0-1). All fields of a particular EQADC_CFSSR register are captured at the beginning of a command transfer to the CBuffer associated with that register. Note that captured status register values are associated with previous command transfer. This means that the CFSSR registers capture the status registers before the status registers change because of the transfer of the current command that is about to be popped from the CFIFO. The EQADC_CFSSR registers are read only. Writing to the EQADC_CFSSR registers has no effect.

Address: 0x00A0 Access: User read/write

| | | | | | | | | | | | | | | | | | | | | | | |
|-------|-----------|---------|----|-----------|----|------------|-----------|----|----|-----------|----|----|-----------|----|----|-----------|---|---|---|---|---|---|
| | 0 | 1 | 2 | 3 | 4 | 5 | 6 | 7 | 8 | 9 | 10 | 11 | 12 | 13 | 14 | 15 | | | | | | |
| R | CFS0_TCB0 | | | CFS1_TCB0 | | | CFS2_TCB0 | | | CFS3_TCB0 | | | CFS4_TCB0 | | | CFS5_TCB0 | | | 0 | 0 | 0 | 0 |
| W | | | | | | | | | | | | | | | | | | | | | | |
| Reset | 0 | 0 | 0 | 0 | 0 | 0 | 0 | 0 | 0 | 0 | 0 | 0 | 0 | 0 | 0 | 0 | 0 | 0 | 0 | 0 | 0 | |
| | | | | | | | | | | | | | | | | | | | | | | |
| | 16 | 17 | 18 | 19 | 20 | 21 | 22 | 23 | 24 | 25 | 26 | 27 | 28 | 29 | 30 | 31 | | | | | | |
| R | 0 | LCFTCB0 | | | | TC_LCFTCB0 | | | | | | | | | | | | | | | | |
| W | | | | | | | | | | | | | | | | | | | | | | |
| Reset | 0 | 1 | 1 | 1 | 1 | 0 | 0 | 0 | 0 | 0 | 0 | 0 | 0 | 0 | 0 | 0 | 0 | 0 | 0 | 0 | 0 | |

Figure 27-15. EQADC CFIFO Status Snapshot Register 0 (EQADC_CFSSR0)

Address: 0x00A4 Access: User read/write

| | | | | | | | | | | | | | | | | | | | | | | |
|-------|-----------|---------|----|-----------|----|------------|-----------|----|----|-----------|----|----|-----------|----|----|-----------|---|---|---|---|---|---|
| | 0 | 1 | 2 | 3 | 4 | 5 | 6 | 7 | 8 | 9 | 10 | 11 | 12 | 13 | 14 | 15 | | | | | | |
| R | CFS0_TCB1 | | | CFS1_TCB1 | | | CFS2_TCB1 | | | CFS3_TCB1 | | | CFS4_TCB1 | | | CFS5_TCB1 | | | 0 | 0 | 0 | 0 |
| W | | | | | | | | | | | | | | | | | | | | | | |
| Reset | 0 | 0 | 0 | 0 | 0 | 0 | 0 | 0 | 0 | 0 | 0 | 0 | 0 | 0 | 0 | 0 | 0 | 0 | 0 | 0 | 0 | |
| | | | | | | | | | | | | | | | | | | | | | | |
| | 16 | 17 | 18 | 19 | 20 | 21 | 22 | 23 | 24 | 25 | 26 | 27 | 28 | 29 | 30 | 31 | | | | | | |
| R | 0 | LCFTCB1 | | | | TC_LCFTCB1 | | | | | | | | | | | | | | | | |
| W | | | | | | | | | | | | | | | | | | | | | | |
| Reset | 0 | 1 | 1 | 1 | 1 | 0 | 0 | 0 | 0 | 0 | 0 | 0 | 0 | 0 | 0 | 0 | 0 | 0 | 0 | 0 | 0 | |

Figure 27-16. EQADC CFIFO Status Snapshot Register 1 (EQADC_CFSSR1)

Table 27-14. EQADC_CFSSRx Field Descriptions

| Field | Description |
|-------------------|---|
| 0–11 CFSx_TCBn | CFIFO Status at Transfer to CBuffern ($n=0,1$). CFSx_TCBn indicates the CFIFOx status of previously completed command transfer. CFSx_TCBn is a copy of the corresponding CFSx in the Section 27.6.2.10, EQADC CFIFO Status Register (EQADC_CFSSR) , captured at the time a current command transfer to CBuffern is initiated. |
| 12–16 | Reserved |

Table 27-14. EQADC_CFSSRx Field Descriptions (continued)

| Field | Description |
|------------------------|--|
| 17–20 LCFTCB n | <p>Last CFIFO to Transfer to CBuffern ($n=0,1$). LCFTCBn holds the CFIFO number to have completed a previous command transfer to CBuffern.</p> <p>0000 Last command was transferred from CFIFO0 0001 Last command was transferred from CFIFO1 0010 Last command was transferred from CFIFO2 0011 Last command was transferred from CFIFO3 0100 Last command was transferred from CFIFO4 0101 Last command was transferred from CFIFO5 0110–1110 Reserved 1111 No command was transferred to CBuffern</p> |
| 21–31 TC_LCFTCB n | <p>Transfer Counter for Last CFIFO to transfer commands to CBuffern. TC_LCFTCBn indicates the number of commands which have been completely transferred from CFIFOx when a current command transfer from CFIFOx to CBuffern is initiated. TC_LCFTCBn is a copy of the corresponding TC_CFx in the Section 27.6.2.8, EQADC CFIFO Transfer Counter Registers (EQADC_CFTCR), captured at the time a current command transfer from CFIFOx to CBuffern is initiated. This field has no meaning when LCFTCBn is 0b1111.</p> |

27.6.2.10 EQADC CFIFO Status Register (EQADC_CFSR)

The EQADC CFIFO Status Register (EQADC_CFSR) contains the current CFIFO status. The EQADC_CFSR registers is read only. Writing to the EQADC_CFSR register has no effect.

Address: 0x00AC

Access: User read only

| | | | | | | | | | | | | | | | | |
|-------|------|----|------|----|------|----|------|----|------|----|------|----|----|----|----|----|
| | 0 | 1 | 2 | 3 | 4 | 5 | 6 | 7 | 8 | 9 | 10 | 11 | 12 | 13 | 14 | 15 |
| R | CFS0 | | CFS1 | | CFS2 | | CFS3 | | CFS4 | | CFS5 | | 0 | 0 | 0 | 0 |
| W | | | | | | | | | | | | | | | | |
| Reset | 0 | 0 | 0 | 0 | 0 | 0 | 0 | 0 | 0 | 0 | 0 | 0 | 0 | 0 | 0 | 0 |
| | 16 | 17 | 18 | 19 | 20 | 21 | 22 | 23 | 24 | 25 | 26 | 27 | 28 | 29 | 30 | 31 |
| R | 0 | 0 | 0 | 0 | 0 | 0 | 0 | 0 | 0 | 0 | 0 | 0 | 0 | 0 | 0 | 0 |
| W | | | | | | | | | | | | | | | | |
| Reset | 0 | 0 | 0 | 0 | 0 | 0 | 0 | 0 | 0 | 0 | 0 | 0 | 0 | 0 | 0 | 0 |

Figure 27-17. EQADC CFIFO Status Register (EQADC_CFSR)

Table 27-15. EQADC_CFSR Field Descriptions

| Field | Description |
|--------------|--|
| 0–11 CFSx | CFIFO Status. CFSx indicates the current status of CFIFOx. 00 Idle: CFIFO is disabled. CFIFO is in single-scan edge or level trigger mode and does not have SSS asserted. EQADC completed the transfer of the last entry of the CQueue in single-scan mode. 01 Reserved 10 Waiting for trigger: CFIFO Mode is modified to continuous-scan edge or level trigger mode. CFIFO Mode is modified to single-scan edge or level trigger mode and SSS is asserted. CFIFO Mode is modified to single-scan software trigger mode and SSS is negated. CFIFO is paused. EQADC transferred the last entry of the queue in continuous-scan edge trigger mode. 11 Triggered: CFIFO is triggered. |
| 12–31 | Reserved |

27.6.2.11 EQADC Red Line Client Configuration Register (EQADC_REDLCR)

The EQADC Red Line Client Configuration Register (EQADC_REDLCR) contains bits used to control which STAC bus server data slot the EQADC selects to apply an external timestamp from either eTPU module to an ADC sample. Two server data slots are specified in the EQADC_REDLCR register, and which is used is specified in the on-chip ADC0/1 control registers, see [Section 27.6.3.1, ADC0/1 Control Registers \(ADC0_CR and ADC1_CR\)](#). The register also allows selection of which 16 bits are used from the 24 bit external time base value. The server and bit selection applies to both ADC0/1.

Address: EQADC_BASE+0x0D0

Access: User read/write

| | | | | | | | | | | | | | | | | |
|-------|--------|----|----|----|------|----|----|----|--------|----|----|----|------|----|----|----|
| | 0 | 1 | 2 | 3 | 4 | 5 | 6 | 7 | 8 | 9 | 10 | 11 | 12 | 13 | 14 | 15 |
| R | 0 | 0 | 0 | 0 | 0 | 0 | 0 | 0 | 0 | 0 | 0 | 0 | 0 | 0 | 0 | 0 |
| W | | | | | | | | | | | | | | | | |
| Reset | 0 | 0 | 0 | 0 | 0 | 0 | 0 | 0 | 0 | 0 | 0 | 0 | 0 | 0 | 0 | 0 |
| | 16 | 17 | 18 | 19 | 20 | 21 | 22 | 23 | 24 | 25 | 26 | 27 | 28 | 29 | 30 | 31 |
| R | REDBS2 | | | | SRV2 | | | | REDBS1 | | | | SRV1 | | | |
| W | | | | | | | | | | | | | | | | |
| Reset | 0 | 0 | 0 | 0 | 0 | 0 | 0 | 0 | 0 | 0 | 0 | 0 | 0 | 0 | 0 | 0 |

Figure 27-18. EQADC Red Line Client Configuration Register (EQADC_REDLCR)

Table 27-16. EQADC_REDCCR Field Descriptions

| Field | Description | | | | | | | | | | | | | | | | | | | | | | |
|--------------------------|---|-------------|---------------|--------|--------------|--------|--------------|--------|--------------|--------|--------------|-----------------|--------------|--------|--------------|--------|--------------|--------|--------------|--------|--------------|--------|----------|
| 0–15 | Reserved | | | | | | | | | | | | | | | | | | | | | | |
| 16–19 24–27 REDBSm | <p>Red Line Timebase Bits Selection m ($m=1,2$)—Selects 16 bits from the total of 24 bits that are received from the Red Line interface as described in below. Consider TBASEm[0:23] the selected time base from slot SRVm:</p> <table border="1" style="margin-left: auto; margin-right: auto;"> <thead> <tr> <th>REDBSm[0:3]</th> <th>Selected Bits</th> </tr> </thead> <tbody> <tr><td>0b0000</td><td>TBASEm[0:15]</td></tr> <tr><td>0b0001</td><td>TBASEm[1:16]</td></tr> <tr><td>0b0010</td><td>TBASEm[2:17]</td></tr> <tr><td>0b0011</td><td>TBASEm[3:18]</td></tr> <tr><td>0b0100</td><td>TBASEm[4:19]</td></tr> <tr><td>0b0101</td><td>TBASEm[5:20]</td></tr> <tr><td>0b0110</td><td>TBASEm[6:21]</td></tr> <tr><td>0b0111</td><td>TBASEm[7:22]</td></tr> <tr><td>0b1000</td><td>TBASEm[8:23]</td></tr> <tr><td>Others</td><td>Reserved</td></tr> </tbody> </table> | REDBSm[0:3] | Selected Bits | 0b0000 | TBASEm[0:15] | 0b0001 | TBASEm[1:16] | 0b0010 | TBASEm[2:17] | 0b0011 | TBASEm[3:18] | 0b0100 | TBASEm[4:19] | 0b0101 | TBASEm[5:20] | 0b0110 | TBASEm[6:21] | 0b0111 | TBASEm[7:22] | 0b1000 | TBASEm[8:23] | Others | Reserved |
| REDBSm[0:3] | Selected Bits | | | | | | | | | | | | | | | | | | | | | | |
| 0b0000 | TBASEm[0:15] | | | | | | | | | | | | | | | | | | | | | | |
| 0b0001 | TBASEm[1:16] | | | | | | | | | | | | | | | | | | | | | | |
| 0b0010 | TBASEm[2:17] | | | | | | | | | | | | | | | | | | | | | | |
| 0b0011 | TBASEm[3:18] | | | | | | | | | | | | | | | | | | | | | | |
| 0b0100 | TBASEm[4:19] | | | | | | | | | | | | | | | | | | | | | | |
| 0b0101 | TBASEm[5:20] | | | | | | | | | | | | | | | | | | | | | | |
| 0b0110 | TBASEm[6:21] | | | | | | | | | | | | | | | | | | | | | | |
| 0b0111 | TBASEm[7:22] | | | | | | | | | | | | | | | | | | | | | | |
| 0b1000 | TBASEm[8:23] | | | | | | | | | | | | | | | | | | | | | | |
| Others | Reserved | | | | | | | | | | | | | | | | | | | | | | |
| 20–23 28–31 SRVm | <p>Red Line Server Data Slot Selector m ($m=1,2$)—Indicates the slot number that contains the desired time base value sent by the Red Line server. This value selects which eTPU timebase on the STAC bus is used to timestamp an ADC sample.</p> <table border="1" style="margin-left: auto; margin-right: auto;"> <thead> <tr> <th>SRVm[0:3]</th> <th>eTPU Timebase</th> </tr> </thead> <tbody> <tr><td>0b0000</td><td>eTPUA TCR1</td></tr> <tr><td>0b0001</td><td>eTPUB TCR1</td></tr> <tr><td>0b0010</td><td>eTPUA TCR2</td></tr> <tr><td>0b0011</td><td>eTPUB TCR2</td></tr> <tr><td>0b0100 - 0b1111</td><td>Reserved</td></tr> </tbody> </table> | SRVm[0:3] | eTPU Timebase | 0b0000 | eTPUA TCR1 | 0b0001 | eTPUB TCR1 | 0b0010 | eTPUA TCR2 | 0b0011 | eTPUB TCR2 | 0b0100 - 0b1111 | Reserved | | | | | | | | | | |
| SRVm[0:3] | eTPU Timebase | | | | | | | | | | | | | | | | | | | | | | |
| 0b0000 | eTPUA TCR1 | | | | | | | | | | | | | | | | | | | | | | |
| 0b0001 | eTPUB TCR1 | | | | | | | | | | | | | | | | | | | | | | |
| 0b0010 | eTPUA TCR2 | | | | | | | | | | | | | | | | | | | | | | |
| 0b0011 | eTPUB TCR2 | | | | | | | | | | | | | | | | | | | | | | |
| 0b0100 - 0b1111 | Reserved | | | | | | | | | | | | | | | | | | | | | | |

27.6.2.12 EQADC CFIFO Registers (EQADC_CFxRw) (x=0, ...,5; w=0, ..., 3)

The EQADC CFIFO Registers (EQADC_CFxRw) (x=0, ..., 5; w=0, ..., 3) provide visibility of the contents of a CFIFO for debugging purposes. Each CFIFO has four registers which are uniquely mapped to its four 32-bit entries. Refer to [Section 27.7.4, EQADC Command FIFOs](#), for more information on CFIFOs. These registers are read only. Data written to these registers is ignored.

Address: 0x0100, 0x0104, 0x0108, 01010C

Access: User read only

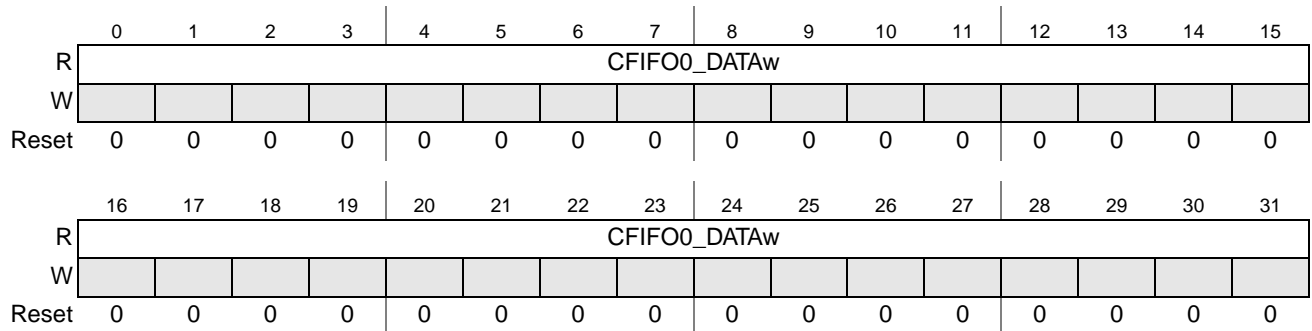

Figure 27-19. EQADC CFIFO0 Registers (EQADC_CF0Rw) (w=0, ..., 3)

Address: 0x0140, 0x0144, 0x0148, 01014C

Access: User read only

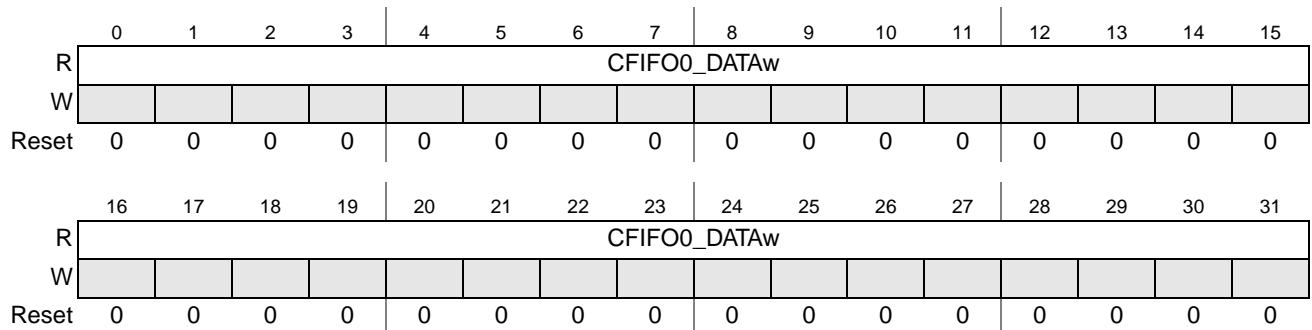

Figure 27-20. EQADC CFIFO1 Registers (EQADC_CF1Rw) (w=0, ..., 3)

Address: 0x0180, 0x0184, 0x0188, 01018C

Access: User read only

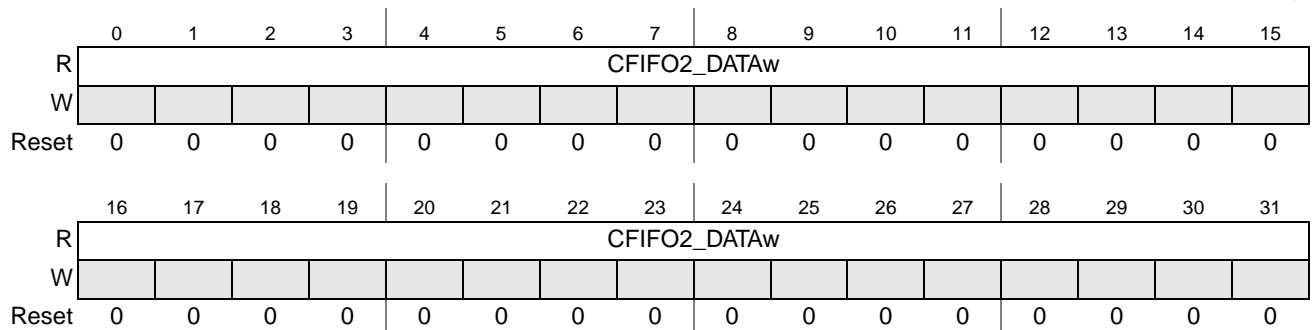

Figure 27-21. EQADC CFIFO2 Registers (EQADC_CF2Rw) (w=0, ..., 3)

Address: 0x01C0, 0x01C4, 0x01C8, 0101CC Access: User read only

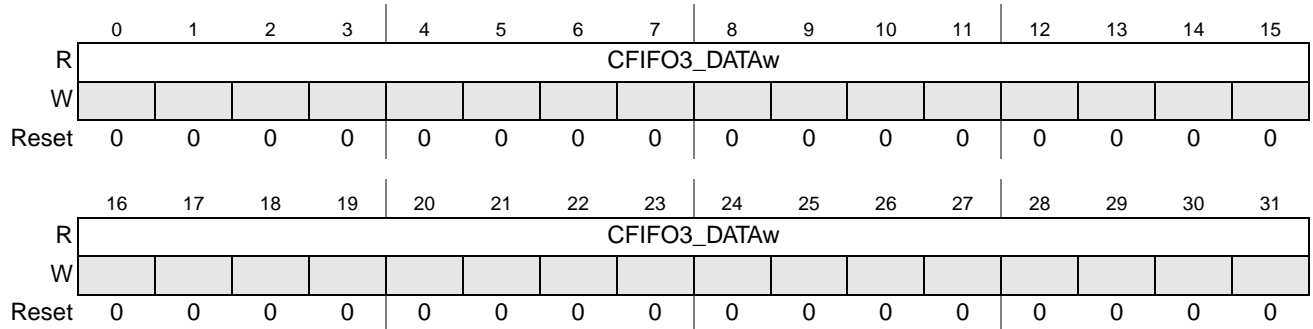

Figure 27-22. EQADC CFIFO3 Registers (EQADC_CF3Rw) (w=0, ..., 3)

Address: 0x0200, 0x0204, 0x0208, 01020C Access: User read only

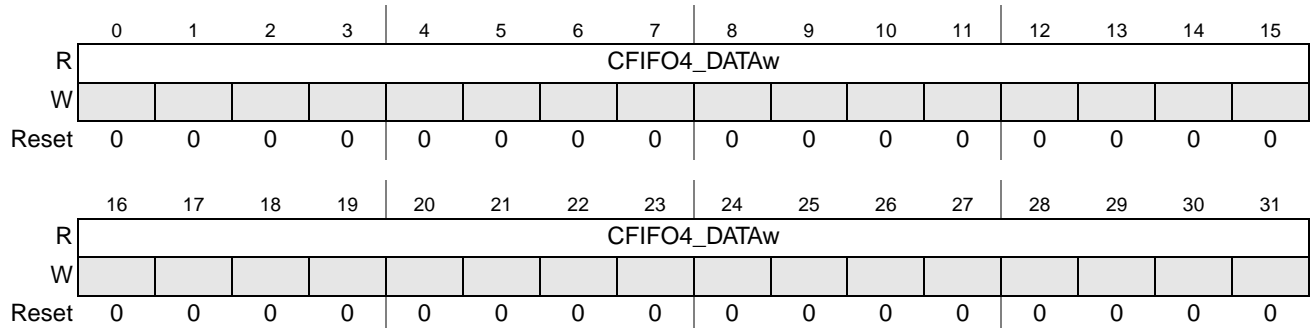

Figure 27-23. EQADC CFIFO4 Registers (EQADC_CF4Rw) (w=0, ..., 3)

Address: 0x0240, 0x0244, 0x0248, 01024C Access: User read only

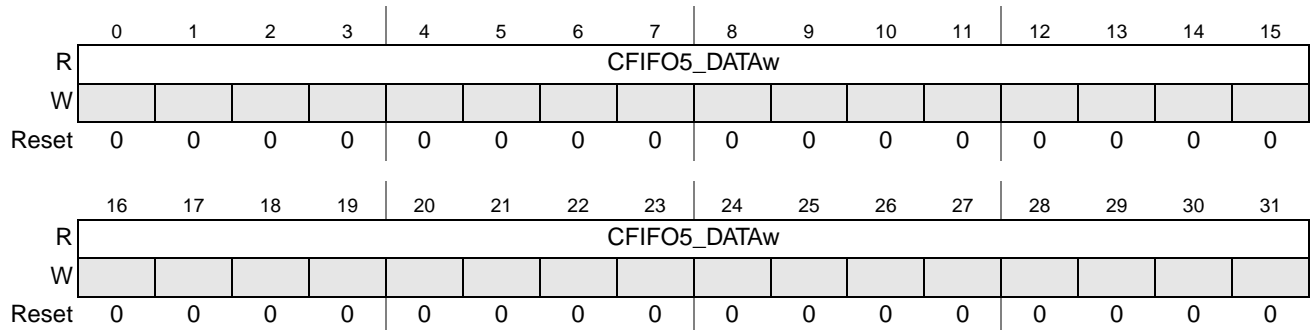

Figure 27-24. EQADC CFIFO5 Registers (EQADC_CF5Rw) (w=0, ..., 3)

Table 27-17. EQADC_CFxRw Field Description

| Field | Description |
|-----------------------|--|
| 0–31 CFIFOx_DATAw[| CFIFOx Data w (w = 0, ..., 3). Reading CFIFOx_DATAw returns the value stored on the w th entry of CFIFOx. Each CFIFO is composed of four 32-bit entries, with register 0 being mapped to the one with the smallest memory mapped address. |

27.6.2.13 EQADC CFIFO0 Extension Registers (EQADC_CF0ERw) (w=0, ..., 3)

The EQADC CFIFO0 Extension Registers (EQADC_CF0ERw) (w=0, ..., 3) provide visibility of the contents of the extended portion of CFIFO0 for debugging purposes. There are four registers which are uniquely mapped to its four 32-bit entries. Refer to [Section 27.7.4, EQADC Command FIFOs](#), for more information on CFIFOs. These registers are read only. Data written to these registers is ignored.

Address: 0x0110, 0x0114, 0x0118, 01011C

Access: User read only

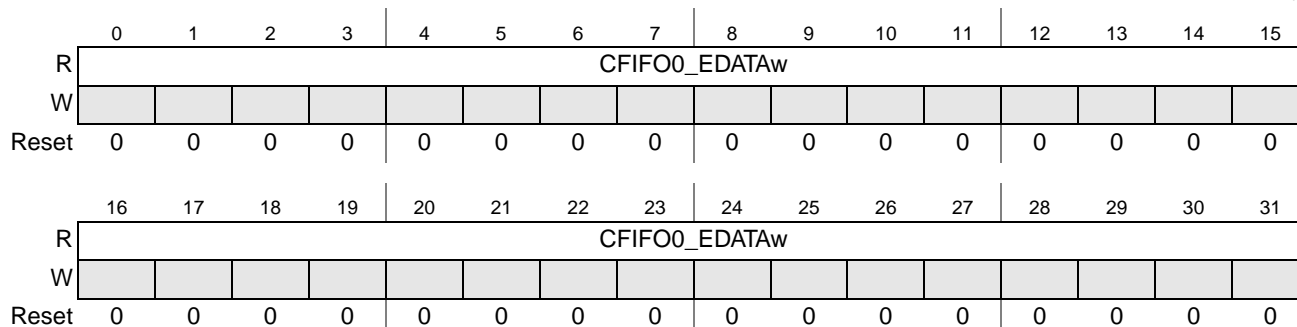

Figure 27-25. EQADC CFIFO0 Extension Registers (EQADC_CF0ERw) (w=0, ..., 3)

Table 27-18. EQADC_CF0ERw Field Description

| Field | Description |
|-----------------------|--|
| 0–31 CFIFO0_EDATAw | CFIFOx Extension Data w (w = 0, ..., 3). Reading CFIFO0_EDATAw returns the value stored on the w th entry of CFIFO0's extended portion. |

27.6.2.14 EQADC RFIFO Registers (EQADC_RFxRw) (x=0, ..., 5; w=0, ..., 3)

The EQADC RFIFO Registers (EQADC_RFxRw) (x=0, ..., 5; w=0, ..., 3) provide visibility of the contents of a RFIFO for debugging purposes. Each RFIFO has four registers which are uniquely mapped to its four 16-bit entries. Refer to [Section 27.7.5, EQADC Result FIFOs](#), for more information on RFIFOs. These registers are read only. Data written to these registers is ignored.

Address: 0x0300, 0x0304, 0x0308, 01030C

Access: User read only

| | | | | | | | | | | | | | | | | |
|-------|--------------|----|----|----|----|----|----|----|----|----|----|----|----|----|----|----|
| | 0 | 1 | 2 | 3 | 4 | 5 | 6 | 7 | 8 | 9 | 10 | 11 | 12 | 13 | 14 | 15 |
| R | 0 | 0 | 0 | 0 | 0 | 0 | 0 | 0 | 0 | 0 | 0 | 0 | 0 | 0 | 0 | 0 |
| W | | | | | | | | | | | | | | | | |
| Reset | 0 | 0 | 0 | 0 | 0 | 0 | 0 | 0 | 0 | 0 | 0 | 0 | 0 | 0 | 0 | 0 |
| | 16 | 17 | 18 | 19 | 20 | 21 | 22 | 23 | 24 | 25 | 26 | 27 | 28 | 29 | 30 | 31 |
| R | RFIFO0_DATAw | | | | | | | | | | | | | | | |
| W | | | | | | | | | | | | | | | | |
| Reset | 0 | 0 | 0 | 0 | 0 | 0 | 0 | 0 | 0 | 0 | 0 | 0 | 0 | 0 | 0 | 0 |

Figure 27-26. EQADC RFIFO0 Registers (EQADC_RF0Rw) (w=0, ..., 3)

Address: 0x0340, 0x0344, 0x0348, 01034C

Access: User read only

| | | | | | | | | | | | | | | | | |
|-------|--------------|----|----|----|----|----|----|----|----|----|----|----|----|----|----|----|
| | 0 | 1 | 2 | 3 | 4 | 5 | 6 | 7 | 8 | 9 | 10 | 11 | 12 | 13 | 14 | 15 |
| R | 0 | 0 | 0 | 0 | 0 | 0 | 0 | 0 | 0 | 0 | 0 | 0 | 0 | 0 | 0 | 0 |
| W | | | | | | | | | | | | | | | | |
| Reset | 0 | 0 | 0 | 0 | 0 | 0 | 0 | 0 | 0 | 0 | 0 | 0 | 0 | 0 | 0 | 0 |
| | 16 | 17 | 18 | 19 | 20 | 21 | 22 | 23 | 24 | 25 | 26 | 27 | 28 | 29 | 30 | 31 |
| R | RFIFO1_DATAw | | | | | | | | | | | | | | | |
| W | | | | | | | | | | | | | | | | |
| Reset | 0 | 0 | 0 | 0 | 0 | 0 | 0 | 0 | 0 | 0 | 0 | 0 | 0 | 0 | 0 | 0 |

Figure 27-27. EQADC RFIFO1 Registers (EQADC_RF0Rw) (w=0, ..., 3)

Address: 0x0380, 0x0384, 0x0388, 01038C

Access: User read only

| | | | | | | | | | | | | | | | | |
|-------|--------------|----|----|----|----|----|----|----|----|----|----|----|----|----|----|----|
| | 0 | 1 | 2 | 3 | 4 | 5 | 6 | 7 | 8 | 9 | 10 | 11 | 12 | 13 | 14 | 15 |
| R | 0 | 0 | 0 | 0 | 0 | 0 | 0 | 0 | 0 | 0 | 0 | 0 | 0 | 0 | 0 | 0 |
| W | | | | | | | | | | | | | | | | |
| Reset | 0 | 0 | 0 | 0 | 0 | 0 | 0 | 0 | 0 | 0 | 0 | 0 | 0 | 0 | 0 | 0 |
| | 16 | 17 | 18 | 19 | 20 | 21 | 22 | 23 | 24 | 25 | 26 | 27 | 28 | 29 | 30 | 31 |
| R | RFIFO2_DATAw | | | | | | | | | | | | | | | |
| W | | | | | | | | | | | | | | | | |
| Reset | 0 | 0 | 0 | 0 | 0 | 0 | 0 | 0 | 0 | 0 | 0 | 0 | 0 | 0 | 0 | 0 |

Figure 27-28. EQADC RFIFO2 Registers (EQADC_RF0Rw) (w=0, ..., 3)

Address: 0x0380, 0x0384, 0x0388, 01038C

Access: User read only

| | | | | | | | | | | | | | | | | |
|-------|---|---|---|---|---|---|---|---|---|---|----|----|----|----|----|----|
| | 0 | 1 | 2 | 3 | 4 | 5 | 6 | 7 | 8 | 9 | 10 | 11 | 12 | 13 | 14 | 15 |
| R | 0 | 0 | 0 | 0 | 0 | 0 | 0 | 0 | 0 | 0 | 0 | 0 | 0 | 0 | 0 | 0 |
| W | | | | | | | | | | | | | | | | |
| Reset | 0 | 0 | 0 | 0 | 0 | 0 | 0 | 0 | 0 | 0 | 0 | 0 | 0 | 0 | 0 | 0 |

| | | | | | | | | | | | | | | | | |
|-------|--------------|----|----|----|----|----|----|----|----|----|----|----|----|----|----|----|
| | 16 | 17 | 18 | 19 | 20 | 21 | 22 | 23 | 24 | 25 | 26 | 27 | 28 | 29 | 30 | 31 |
| R | RFIFO2_DATAw | | | | | | | | | | | | | | | |
| W | | | | | | | | | | | | | | | | |
| Reset | 0 | 0 | 0 | 0 | 0 | 0 | 0 | 0 | 0 | 0 | 0 | 0 | 0 | 0 | 0 | 0 |

Figure 27-29. EQADC RFIFO2 Registers (EQADC_RF0Rw) (w=0, ..., 3)

Address: 0x03C0, 0x03C4, 0x03C8, 0103CC

Access: User read only

| | | | | | | | | | | | | | | | | |
|-------|---|---|---|---|---|---|---|---|---|---|----|----|----|----|----|----|
| | 0 | 1 | 2 | 3 | 4 | 5 | 6 | 7 | 8 | 9 | 10 | 11 | 12 | 13 | 14 | 15 |
| R | 0 | 0 | 0 | 0 | 0 | 0 | 0 | 0 | 0 | 0 | 0 | 0 | 0 | 0 | 0 | 0 |
| W | | | | | | | | | | | | | | | | |
| Reset | 0 | 0 | 0 | 0 | 0 | 0 | 0 | 0 | 0 | 0 | 0 | 0 | 0 | 0 | 0 | 0 |

| | | | | | | | | | | | | | | | | |
|-------|--------------|----|----|----|----|----|----|----|----|----|----|----|----|----|----|----|
| | 16 | 17 | 18 | 19 | 20 | 21 | 22 | 23 | 24 | 25 | 26 | 27 | 28 | 29 | 30 | 31 |
| R | RFIFO3_DATAw | | | | | | | | | | | | | | | |
| W | | | | | | | | | | | | | | | | |
| Reset | 0 | 0 | 0 | 0 | 0 | 0 | 0 | 0 | 0 | 0 | 0 | 0 | 0 | 0 | 0 | 0 |

Figure 27-30. EQADC RFIFO3 Registers (EQADC_RF0Rw) (w=0, ..., 3)

Address: 0x0400, 0x0404, 0x0408, 01040C

Access: User read only

| | | | | | | | | | | | | | | | | |
|-------|---|---|---|---|---|---|---|---|---|---|----|----|----|----|----|----|
| | 0 | 1 | 2 | 3 | 4 | 5 | 6 | 7 | 8 | 9 | 10 | 11 | 12 | 13 | 14 | 15 |
| R | 0 | 0 | 0 | 0 | 0 | 0 | 0 | 0 | 0 | 0 | 0 | 0 | 0 | 0 | 0 | 0 |
| W | | | | | | | | | | | | | | | | |
| Reset | 0 | 0 | 0 | 0 | 0 | 0 | 0 | 0 | 0 | 0 | 0 | 0 | 0 | 0 | 0 | 0 |

| | | | | | | | | | | | | | | | | |
|-------|--------------|----|----|----|----|----|----|----|----|----|----|----|----|----|----|----|
| | 16 | 17 | 18 | 19 | 20 | 21 | 22 | 23 | 24 | 25 | 26 | 27 | 28 | 29 | 30 | 31 |
| R | RFIFO4_DATAw | | | | | | | | | | | | | | | |
| W | | | | | | | | | | | | | | | | |
| Reset | 0 | 0 | 0 | 0 | 0 | 0 | 0 | 0 | 0 | 0 | 0 | 0 | 0 | 0 | 0 | 0 |

Figure 27-31. EQADC RFIFO4 Registers (EQADC_RF0Rw) (w=0, ..., 3)

Address: 0x0440, 0x0444, 0x0448, 01044C Access: User read only

| | | | | | | | | | | | | | | | | |
|-------|---|---|---|---|---|---|---|---|---|---|----|----|----|----|----|----|
| | 0 | 1 | 2 | 3 | 4 | 5 | 6 | 7 | 8 | 9 | 10 | 11 | 12 | 13 | 14 | 15 |
| R | 0 | 0 | 0 | 0 | 0 | 0 | 0 | 0 | 0 | 0 | 0 | 0 | 0 | 0 | 0 | 0 |
| W | | | | | | | | | | | | | | | | |
| Reset | 0 | 0 | 0 | 0 | 0 | 0 | 0 | 0 | 0 | 0 | 0 | 0 | 0 | 0 | 0 | 0 |

| | | | | | | | | | | | | | | | | |
|-------|--------------|----|----|----|----|----|----|----|----|----|----|----|----|----|----|----|
| | 16 | 17 | 18 | 19 | 20 | 21 | 22 | 23 | 24 | 25 | 26 | 27 | 28 | 29 | 30 | 31 |
| R | RFIFO5_DATAw | | | | | | | | | | | | | | | |
| W | | | | | | | | | | | | | | | | |
| Reset | 0 | 0 | 0 | 0 | 0 | 0 | 0 | 0 | 0 | 0 | 0 | 0 | 0 | 0 | 0 | 0 |

Figure 27-32. EQADC RFIFO5 Registers (EQADC_RF0Rw) (w=0, ..., 3)

Table 27-19. EQADC_CFxRw Field Descriptions

| Field | Description |
|-----------------------|--|
| 0–15 | Reserved |
| 16–31 RFIFOx_DATAw | RFIFOx Data w (w = 0, ..., 3). Reading RFIFOx_DATAw returns the value stored on the w th entry of RFIFOx. Each RFIFO is composed of four 16-bit entries, with register 0 being mapped to the one with the smallest memory mapped address. |

27.6.3 On-Chip ADC Registers

This section describes a list of registers that control on-chip ADC operation. The ADC registers are not part of the CPU accessible memory map. These registers can only be accessed indirectly through configuration commands. There are a set of non-memory mapped registers per ADC, plus a set of registers shared by both ADCs. The address, usage, and access privilege of each register is shown in [Table 27-20](#). Data written to or read from reserved areas of the memory map is undefined.

Their assigned addresses are the values used to set the ADC_REG_ADDRESS field of the read/write configurations commands bound for the on-chip ADCs. These are half-word addresses. Further, the following restrictions apply when accessing these registers:

- Registers ADC0_CR, ADC0_GCCR, ADC0_OCCR, ADC0_AGR1/2 and ADC0_AOR1/2 can only be accessed by configuration commands sent to CBuffer0.
- Registers ADC1_CR, ADC1_GCCR, ADC1_OCCR, ADC1_AGR1/2 and ADC1_AOR1/2 can only be accessed by configuration commands sent to CBuffer1.
- Registers ADC_TSCR, ADC_TBCR, ADC_ACR1-8 and ADC_PUDCR0-7 can be accessed by configuration commands sent to CBuffer0 or to CBuffer1. A data write to any of these registers through a configuration command sent to CBuffer0 will write the same memory location as when writing to it through a configuration command sent to CBuffer1.

NOTE

Simultaneous write accesses from CBuffer0 and CBuffer1 to any of the shared registers are not allowed.

Table 27-20. On-Chip ADC Memory Map

| ADC Address | Use | Access |
|-------------|--|------------|
| 0x00 | ADC0/ADC1 ¹ Conversion Command for Standard Configuration (See Conversion Command Format for the Standard Configuration) | Write |
| 0x01 | ADC0/ADC1 Configuration Control Register (ADC0_CR, ADC1_CR) | Write/Read |
| 0x02 | Time Stamp Control Register (ADC_TSCR) | Write/Read |
| 0x03 | Time Base Counter Register (ADC_TBCR) | Write/Read |
| 0x04 | ADC0/ADC1 Gain Calibration Constant Register (ADC0_GCCR, ADC1_GCCR) | Write/Read |
| 0x05 | ADC0/ADC1 Offset Calibration Constant Register (ADC0_OCCR, ADC1_OCCR) | Write/Read |
| 0x06– 0x07 | Reserved | — |
| 0x08 | ADC0/ADC1 Conversion Command for Alternate Configuration 1 (See Conversion Command Format for Alternate Configurations) | Write |
| 0x09 | ADC0/ADC1 Conversion Command for Alternate Configuration 2 (See Conversion Command Format for Alternate Configurations) | Write |
| 0x0A | ADC0/ADC1 Conversion Command for Alternate Configuration 3 (See Conversion Command Format for Alternate Configurations) | Write |
| 0x0B | ADC0/ADC1 Conversion Command for Alternate Configuration 4 (See Conversion Command Format for Alternate Configurations) | Write |
| 0x0C | ADC0/ADC1 Conversion Command for Alternate Configuration 5 (See Conversion Command Format for Alternate Configurations) | Write |
| 0x0D | ADC0/ADC1 Conversion Command for Alternate Configuration 6 (See Conversion Command Format for Alternate Configurations) | Write |
| 0x0E | ADC0/ADC1 Conversion Command for Alternate Configuration 7 (See Conversion Command Format for Alternate Configurations) | Write |
| 0x0F | ADC0/ADC1 Conversion Command for Alternate Configuration 8 (See Conversion Command Format for Alternate Configurations) | Write |
| 0x10–0x2F | Reserved | — |
| 0x30 | Alternate Configuration 1 Control Register (ADC_ACR1) | Write/Read |
| 0x31 | ADC0/ADC1 Alternate Gain 1 Register (ADC0_AGR1, ADC1_AGR1) | Write/Read |
| 0x32 | ADC0/ADC1 Alternate Offset 1 Register (ADC0_AOR1, ADC1_AOR1) | Write/Read |
| 0x33 | Reserved | — |
| 0x34 | Alternate Configuration 2 Control Register (ADC_ACR2) | Write/Read |
| 0x35 | ADC0/ADC1 Alternate Gain 2 Register (ADC0_AGR2, ADC1_AGR2) | Write/Read |
| 0x36 | ADC0/ADC1 Alternate Offset 2 Register (ADC0_AOR2, ADC1_AOR2) | Write/Read |
| 0x37 | Reserved | — |
| 0x38 | Alternate Configuration 3 Control Register (ADC_ACR3) | Write/Read |
| 0x39 | Reserved | — |
| 0x3A | Reserved | — |
| 0x3B | Reserved | — |

Table 27-20. On-Chip ADC Memory Map (continued)

| | | |
|-----------|---|------------|
| 0x3C | Alternate Configuration 4 Control Register (ADC_ACR4) | Write/Read |
| 0x3D | Reserved | — |
| 0x3E | Reserved | — |
| 0x3F | Reserved | — |
| 0x40 | Alternate Configuration 5 Control Register (ADC_ACR5) | Write/Read |
| 0x41 | Reserved | — |
| 0x42 | Reserved | — |
| 0x43 | Reserved | — |
| 0x44 | Alternate Configuration 6 Control Register (ADC_ACR6) | Write/Read |
| 0x45 | Reserved | — |
| 0x46 | Reserved | — |
| 0x47 | Reserved | — |
| 0x48 | Alternate Configuration 7 Control Register (ADC_ACR7) | Write/Read |
| 0x49 | Reserved | — |
| 0x4A | Reserved | — |
| 0x4B | Reserved | — |
| 0x4C | Alternate Configuration 8 Control Register (ADC_ACR8) | Write/Read |
| 0x4D–0x6F | Reserved | — |
| 0x70 | Pull Up/Down Control Register0 (ADC_PUDCR0) | Write/Read |
| 0x71 | Pull Up/Down Control Register1 (ADC_PUDCR1) | Write/Read |
| 0x72 | Pull Up/Down Control Register2 (ADC_PUDCR2) | Write/Read |
| 0x73 | Pull Up/Down Control Register3 (ADC_PUDCR3) | Write/Read |
| 0x74 | Pull Up/Down Control Register4 (ADC_PUDCR4) | Write/Read |
| 0x75 | Pull Up/Down Control Register5 (ADC_PUDCR5) | Write/Read |
| 0x76 | Pull Up/Down Control Register6 (ADC_PUDCR6) | Write/Read |
| 0x77 | Pull Up/Down Control Register7 (ADC_PUDCR7) | Write/Read |
| 0x78–0x97 | Reserved for ADC_PUDCR8 to ADC_PUDCR39 | — |
| 0x98–0xFF | Reserved | — |

NOTES:

¹ Throughout the table, ADC0/ADC1 indicates that if the command is stored in CBuffer0 it will be applied to ADC0 and if in CBuffer1 it applies to ADC1. If this indication is omitted the register applies for both ADC0 and ADC1, independent of the CBuffer used.

27.6.3.1 ADC0/1 Control Registers (ADC0_CR and ADC1_CR)

The ADC0/1 Control Registers (ADC0/1_CR) is used to define the standard configuration of the ADC. In the standard configuration, the parameters contained in the Alternate Configuration Control Registers (ADC_ACR1-8) are fixed at their reset value. A conversion uses the standard configuration when the

conversion command (with the standard format) is written to address 0x00 of the on-chip ADC memory map. Refer to [Conversion Command Format for the Standard Configuration](#).

ADC0 Register Address: 0x01

| | | | | | | | | | | | | | | | | |
|-------|------|---|---|---|------|---|---|---|---|---|------|-------------|----|----|----|----|
| | 0 | 1 | 2 | 3 | 4 | 5 | 6 | 7 | 8 | 9 | 10 | 11 | 12 | 13 | 14 | 15 |
| R | ADC0 | 0 | 0 | 0 | ADC0 | 0 | 0 | 0 | 0 | 0 | ADC0 | ADC0_CLK_PS | | | | |
| W | _EN | | | | _EM | | | | | | _CLK | | | | | |
| | | | | | UX | | | | | | _SEL | | | | | |
| Reset | 0 | 0 | 0 | 0 | 0 | 0 | 0 | 0 | 0 | 0 | 0 | 1 | 1 | 1 | 1 | 1 |

ADC1 Register Address: 0x01

| | | | | | | | | | | | | | | | | |
|-------|------|---|---|---|------|---|---|---|---|---|------|-------------|----|----|----|----|
| | 0 | 1 | 2 | 3 | 4 | 5 | 6 | 7 | 8 | 9 | 10 | 11 | 12 | 13 | 14 | 15 |
| R | ADC1 | 0 | 0 | 0 | ADC1 | 0 | 0 | 0 | 0 | 0 | ADC1 | ADC1_CLK_PS | | | | |
| W | _EN | | | | _EM | | | | | | _CLK | | | | | |
| | | | | | UX | | | | | | _SEL | | | | | |
| Reset | 0 | 0 | 0 | 0 | 0 | 0 | 0 | 0 | 0 | 0 | 0 | 1 | 1 | 1 | 1 | 1 |

Figure 27-33. ADC0/1 Control Registers (ADC0/1_CR)

Table 27-21. EQADC_CFRw Field Descriptions

| Field | Description |
|------------------------|--|
| 0 ADC0/1_EN | <p>Enable bit for ADC0/1. ADC0/1_EN enables ADC0/1 to perform A/D conversions. Refer to Section 27.7.6.1, Enabling and Disabling the On-chip ADCs, for details.</p> <p>0 ADC is disabled. Clock supply to ADC0/1 is stopped. 1 ADC is enabled and ready to perform A/D conversions.</p> <p>Note: The bias generator circuit inside the ADC hard macro ceases functioning when both ADC0_EN and ADC1_EN bits are negated.</p> <p>Note: Conversion commands sent to the CBuffer of a disabled ADC are ignored by the ADC control hardware.</p> <p>Note: When the ADC0/1_EN status is changed from asserted to negated, the ADC Clock will not stop until it reaches its low phase.</p> |
| 1–3 | Reserved |
| 4 ADC0/1_EMUX | <p>External Multiplexer enable for ADC0/1. When ADC0/1_EMUX is asserted, the MA pins will output digital values according to the number of the external channel being converted for selecting external multiplexer inputs. Refer to Section 27.7.7, Internal/External Multiplexing, for a detailed description about how ADC0/1_EMUX affects channel number decoding.</p> <p>0 External multiplexer disabled; no external multiplexer channels can be selected. 1 External multiplexer enabled; external multiplexer channels can be selected.</p> <p>Note: Both ADC0 and ADC1 of an eQADC module pair must be enabled before calibrating or using either ADC0 or ADC1 of the pair. Failure to enable both ADC0 and ADC1 of the pair can result in inaccurate conversions.</p> <p>Note: Both ADC0/1_EMUX bits must not be asserted at the same time.</p> <p>Note: The ADC0/1_EMUX bit must only be written when the ADC0/1_EN bit is negated. ADC0/1_EMUX can be set during the same write cycle used to set ADC0/1_EN.</p> |
| 5–9 | Reserved |
| 10 ADC0/1_CLK_SEL | <p>Clock Selector for ADC0/1. The ADC0/1_CLK_SEL is used to select between the platform clock signal or the prescaler output signal. The prescaler provides the platform clock signal divided by a even factor from 2 to 64. This is required to permit the ADC to run as fast as possible when the device is in Low Power Active mode and platform clock is around 1 MHz.</p> <p>0 Prescaler output clock is selected. 1 Platform clock is selected - maximum frequency.</p> <p>Note: The ADC0/1_CLK_SEL bits must only be written when the ADC0/1_EN bit is negated. ADC0/1_CLK_SEL can be set during the same write cycle used to set ADC0/1_EN.</p> |
| 11–15 ADC0/1_CLK_PS | <p>Clock Prescaler Field for ADC0/1. The ADC0/1_CLK_PS field controls the platform clock divide factor for the ADC0/1 clock as in Table 27-22. See Section 27.7.6.2, ADC Clock and Conversion Speed, for details about how to set ADC0/1_CLK_PS.</p> <p>Note: The ADC0/1_CLK_PS field must only be written when the ADC0/1_EN bit is negated. This field can be configured during the same write cycle used to set ADC0/1_EN.</p> |

Table 27-22. Platform Clock Divide Factor for ADC Clock

| ADC0/1_CLK_PS[0:4] | Platform Clock Divide Factor |
|--------------------|------------------------------|
| 0b00000 | 2 |
| 0b00001 | 4 |
| 0b00010 | 6 |
| 0b00011 | 8 |
| 0b00100 | 10 |
| 0b00101 | 12 |
| 0b00110 | 14 |
| 0b00111 | 16 |
| 0b01000 | 18 |
| 0b01001 | 20 |
| 0b01010 | 22 |
| 0b01011 | 24 |
| 0b01100 | 26 |
| 0b01101 | 28 |
| 0b01110 | 30 |
| 0b01111 | 32 |
| 0b10000 | 34 |
| 0b10001 | 36 |
| 0b10010 | 38 |
| 0b10011 | 40 |
| 0b10100 | 42 |
| 0b10101 | 44 |
| 0b10110 | 46 |
| 0b10111 | 48 |
| 0b11000 | 50 |
| 0b11001 | 52 |
| 0b11010 | 54 |
| 0b11011 | 56 |
| 0b11100 | 58 |
| 0b11101 | 60 |
| 0b11110 | 62 |
| 0b11111 | 64 |

27.6.3.2 ADC Time Stamp Control Register (ADC_TSCR)

The ADC Time Stamp Control Register (ADC_TSCR) contains a platform clock divide factor used in the making of the time base counter clock. It determines at what frequency the time base counter will run. ADC_TSCR can be accessed by configuration commands sent to CBuffer0 or to CBuffer1. A data write to ADC_TSCR through a configuration command sent to CBuffer0 will write the same memory location as when writing to it through a configuration command sent to CBuffer1.

NOTE

Simultaneous write accesses from CBuffer0 and CBuffer1 to ADC_TSCR are not allowed.

ADC0/1 Register Address: 0x02

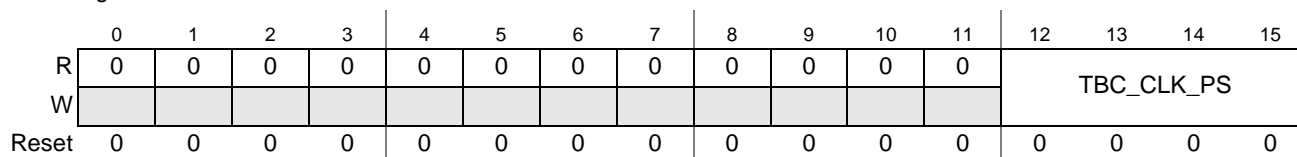

Figure 27-34. ADC Time Stamp Control Register (ADC_TSCR)

Table 27-23. ADC_TSCR Field Descriptions

| Field | Description |
|---------------------|--|
| 0–11 | Reserved |
| 12–15 TBC_CLK_PS | Time Base Counter Clock Prescaler. The TBC_CLK_PS field contains the platform clock divide factor for the time base counter. It controls the accuracy of the time stamp. The prescaler is disabled when TBC_CLK_PS is set to 0b0000. |

Table 27-24. Clock Divide Factor for Time Stamp

| TBC_CLK_PS[0:3] | Platform Clock Divide Factor | Clock to Time Stamp Counter for a 120 MHz Platform Clock (MHz) |
|-----------------|------------------------------|--|
| 0b0000 | Disabled | Disabled |
| 0b0001 | 1 | 120 |
| 0b0010 | 2 | 60 |
| 0b0011 | 4 | 30 |
| 0b0100 | 6 | 20 |
| 0b0101 | 8 | 15 |
| 0b0110 | 10 | 12 |
| 0b0111 | 12 | 10 |
| 0b1000 | 16 | 7.5 |
| 0b1001 | 32 | 3.75 |
| 0b1010 | 64 | 1.88 |
| 0b1011 | 128 | 0.94 |
| 0b1100 | 256 | 0.47 |

Table 27-24. Clock Divide Factor for Time Stamp (continued)

| | | |
|-----------------|----------|------|
| 0b1101 | 512 | 0.23 |
| 0b1110 - 0b1111 | Reserved | — |

NOTE

If TBC_CLK_PS is not set to disabled, it must not be changed to any other value besides disabled. If TBC_CLK_PS is set to disabled it can be changed to any other value.

27.6.3.3 ADC Time Base Counter Registers (ADC_TBCR)

The ADC Time Base Counter Register (ADC_TBCR) contains the current value of the time base counter. ADC_TBCR can be accessed by configuration commands sent to CBuffer0 or to CBuffer1. A data write to ADC_TBCR through a configuration command sent to CBuffer0 will write the same memory location as when writing to it through a configuration command sent to CBuffer1.

NOTE

Simultaneous write accesses from CBuffer0 and CBuffer1 to ADC_TBCR are not allowed.

ADC0/1 Register Address: 0x03

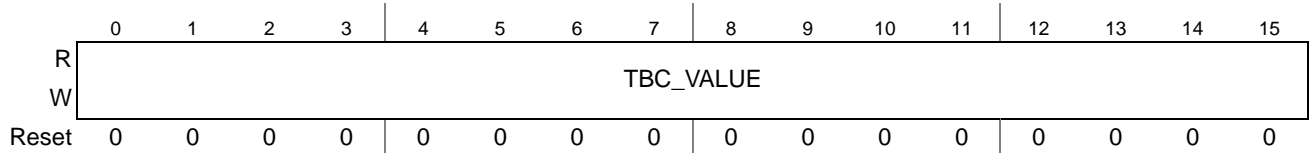

Figure 27-35. ADC Time Base Counter Register (ADC_TBCR)

Table 27-25. ADC_TSCR Field Descriptions

| Field | Description |
|-------------------|---|
| 0–15 TBC_VALUE | Time Base Counter value. The TBC_VALUE field contains the current value of the time base counter. Reading TBC_VALUE returns the current value of time base counter. Writes to TBC_VALUE register load the written data to the counter. The time base counter counts from 0x0000 to 0xFFFF and wraps when reaching 0xFFFF. |

27.6.3.4 ADC0/1 Gain Calibration Constant Registers (ADC0_GCCR and ADC1_GCCR)

The ADC0/1 Gain Calibration Constant Register (ADC0/1_GCCR) contains the gain calibration constant used to fine-tune the ADC0/1 conversion results. Refer to [Section 27.7.6.6, ADC Calibration Feature](#), for details about the calibration scheme used in the EQADC.

ADC0 Register Address: 0x04

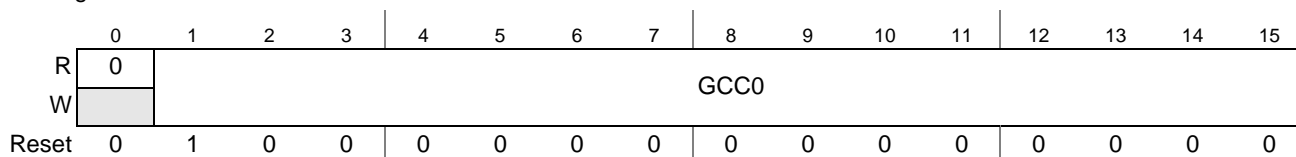

ADC1 Register Address: 0x04

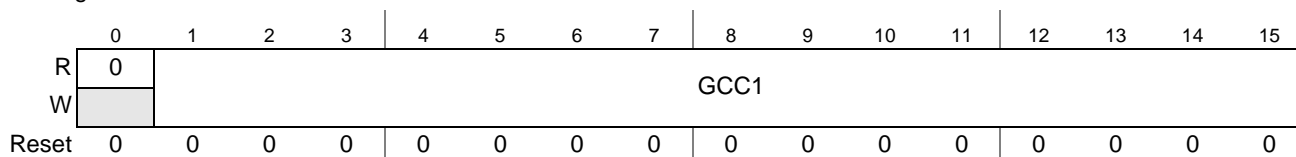

Figure 27-36. ADC0/1 Gain Calibration Constant Registers (ADC0/1_GCCR)

Table 27-26. ADC0/1_GCCR Field Descriptions

| Field | Description |
|----------------|--|
| 0 | Reserved |
| 1–14 GCC0/1 | Gain calibration constant for ADC0/1. GCC0/1 contains the gain calibration constant used to fine-tune ADC0/1 conversion results. It is a unsigned 15-bit fixed pointed value. The gain calibration constant is an unsigned fixed point number expressed in the GCC_INT.GCC_FRAC binary format. The integer part of the gain constant (GCC_INT) contains a single binary digit while its fractional part (GCC_FRAC) contains fourteen digits. For details about the GCC data format refer to Section 27.7.6.2, MAC Unit and Operand Data Format . |

27.6.3.5 ADC0/1 Offset Calibration Constant Registers (ADC0_OCCR and ADC1_OCCR)

The ADC0/1 Offset Calibration Constant Register (ADC0/1_OCCR) contains the offset calibration constant used to fine-tune of ADC0/1 conversion results. The offset constant is a signed 14-bit integer value. Refer to [Section 27.7.6.6, ADC Calibration Feature](#), for details about the calibration scheme used in the EQADC.

ADC0 Register Address: 0x05

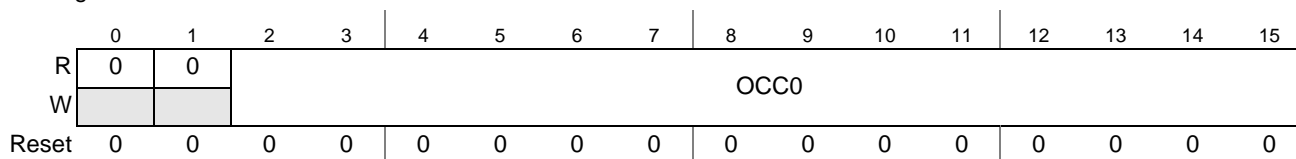

ADC1 Register Address: 0x05

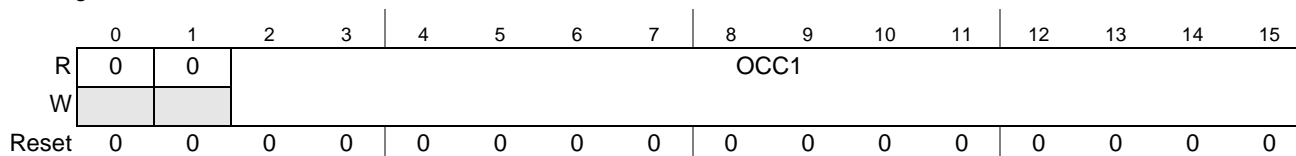

Figure 27-37. ADC0/1 Offset Calibration Constant Registers (ADC0/1_OCCR)

Table 27-27. ADC0/1_OCCR Field Descriptions

| Field | Description |
|----------------|--|
| 0–1 | Reserved |
| 2–15 OCC0/1 | Offset Calibration Constant of ADC0/1. OCC0/1 contains the offset calibration constant used to fine-tune ADC0/1 conversion results. Negative values should be expressed using the two's complement representation. |

27.6.3.6 Alternate Configuration 1-8 Control Registers (ADC_ACR1-8)

The Alternate Configuration Control Registers (ADC_ACR1-8) are used to configure the alternate configurations of the ADC. There are 8 possible alternate configurations, each one associated with one of the ADC_ACR1-8 registers. All alternate configurations share the same standard configuration parameters from the ADC0/1_CR registers, plus additional configuration parameters contained in the ADC_ACR1-8. A conversion uses one of the alternate configurations when the conversion command (with the alternate configuration format) is written to an address in the range 0x08-0x0F of the on-chip ADC memory map. Refer to [Conversion Command Format for Alternate Configurations](#).

ADC0/1 Register Address: 0x30, 0x34, 0x38, 0x3C, 0x40, 0x44, 0x48, 0x4C

Access: User read only

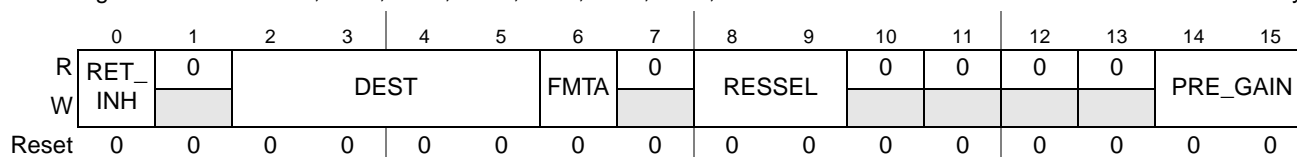

Figure 27-38. Alternate Configuration 1-8 Control Registers (ADC_ACR1-8)

Table 27-28. ADC_ACR1-8 Field Descriptions

| Field | Description | | | | | | | | | | | | | | | | | | | | | | | | | | | | | | | | | | |
|--------------|---|-----------|-------------|------|---|------|---|------|---|------|---|------|---|------|---|------|---|------|---|------|--|------|--|------|--|------|--|------|--|------|--|------|--|------|--|
| 0 RET_INH | <p>Result Transfer Inhibit / Decimation Filter Pre-Fill. This bit is used to inhibit the transfer of the result data from the peripheral module to the result queue. When the module is a Decimation Filter, this bit sets the filter in a special mode (PRE-FILL) in which it does not generate decimated samples out from the conversion results received from the EQADC block, but the conversion samples are used by the filter algorithm. This feature allows a proper initialization of the Decimation Filter without generating any decimated result. Or this bit is useful for sending the result of the ADC to the STAC bus master but not putting the result in the result queue.</p> <p>0 Result transfer to result queue / Decimation Filter in filtering mode 1 No result transfer to result queue / Decimation Filter PRE-FILL mode</p> | | | | | | | | | | | | | | | | | | | | | | | | | | | | | | | | | | |
| 1 | Reserved | | | | | | | | | | | | | | | | | | | | | | | | | | | | | | | | | | |
| 2-5 DEST | <p>Conversion Result Destination Selection. The DEST[0:3] field selects the Decimation Filter destinations of the conversion result generated by the Alternate Conversion Command. This field also affects the behavior of the FMTA bit and the FFMT bit of the conversion command for alternate configurations (see Conversion Command Format for Alternate Configurations).</p> <p>Note: Decimation Filter H is only accessible from the CPU, and cannot be accessed by eQADC_B</p> <table border="1" style="margin-left: 40px;"> <thead> <tr> <th>DEST[0:3]</th> <th>Description</th> </tr> </thead> <tbody> <tr> <td>0000</td> <td>The conversion result is sent to the RFIFOs. The data format is specified by the FFMT bit in the conversion command.</td> </tr> <tr> <td>0001</td> <td>The conversion result is sent to Decimation Filter block A.</td> </tr> <tr> <td>0010</td> <td>The conversion result is sent to Decimation Filter block B.</td> </tr> <tr> <td>0011</td> <td>The conversion result is sent to Decimation Filter block C.</td> </tr> <tr> <td>0100</td> <td>The conversion result is sent to Decimation Filter block D.</td> </tr> <tr> <td>0101</td> <td>The conversion result is sent to Decimation Filter block E.</td> </tr> <tr> <td>0110</td> <td>The conversion result is sent to Decimation Filter block F.</td> </tr> <tr> <td>0111</td> <td>The conversion result is sent to Decimation Filter block G.</td> </tr> <tr> <td>1000</td> <td>The conversion result is sent to Decimation Filter blocks A and E.</td> </tr> <tr> <td>1001</td> <td>The conversion result is sent to Decimation Filter blocks B and E.</td> </tr> <tr> <td>1010</td> <td>The conversion result is sent to Decimation Filter blocks C and E.</td> </tr> <tr> <td>1011</td> <td>The conversion result is sent to Decimation Filter blocks D and E.</td> </tr> <tr> <td>1100</td> <td>The conversion result is sent to Decimation Filter blocks A and G.</td> </tr> <tr> <td>1101</td> <td>The conversion result is sent to Decimation Filter blocks B and G.</td> </tr> <tr> <td>1110</td> <td>The conversion result is sent to Decimation Filter blocks C and G.</td> </tr> <tr> <td>1111</td> <td>The conversion result is sent to Decimation Filter blocks D and G.</td> </tr> </tbody> </table> | DEST[0:3] | Description | 0000 | The conversion result is sent to the RFIFOs. The data format is specified by the FFMT bit in the conversion command. | 0001 | The conversion result is sent to Decimation Filter block A. | 0010 | The conversion result is sent to Decimation Filter block B. | 0011 | The conversion result is sent to Decimation Filter block C. | 0100 | The conversion result is sent to Decimation Filter block D. | 0101 | The conversion result is sent to Decimation Filter block E. | 0110 | The conversion result is sent to Decimation Filter block F. | 0111 | The conversion result is sent to Decimation Filter block G. | 1000 | The conversion result is sent to Decimation Filter blocks A and E. | 1001 | The conversion result is sent to Decimation Filter blocks B and E. | 1010 | The conversion result is sent to Decimation Filter blocks C and E. | 1011 | The conversion result is sent to Decimation Filter blocks D and E. | 1100 | The conversion result is sent to Decimation Filter blocks A and G. | 1101 | The conversion result is sent to Decimation Filter blocks B and G. | 1110 | The conversion result is sent to Decimation Filter blocks C and G. | 1111 | The conversion result is sent to Decimation Filter blocks D and G. |
| DEST[0:3] | Description | | | | | | | | | | | | | | | | | | | | | | | | | | | | | | | | | | |
| 0000 | The conversion result is sent to the RFIFOs. The data format is specified by the FFMT bit in the conversion command. | | | | | | | | | | | | | | | | | | | | | | | | | | | | | | | | | | |
| 0001 | The conversion result is sent to Decimation Filter block A. | | | | | | | | | | | | | | | | | | | | | | | | | | | | | | | | | | |
| 0010 | The conversion result is sent to Decimation Filter block B. | | | | | | | | | | | | | | | | | | | | | | | | | | | | | | | | | | |
| 0011 | The conversion result is sent to Decimation Filter block C. | | | | | | | | | | | | | | | | | | | | | | | | | | | | | | | | | | |
| 0100 | The conversion result is sent to Decimation Filter block D. | | | | | | | | | | | | | | | | | | | | | | | | | | | | | | | | | | |
| 0101 | The conversion result is sent to Decimation Filter block E. | | | | | | | | | | | | | | | | | | | | | | | | | | | | | | | | | | |
| 0110 | The conversion result is sent to Decimation Filter block F. | | | | | | | | | | | | | | | | | | | | | | | | | | | | | | | | | | |
| 0111 | The conversion result is sent to Decimation Filter block G. | | | | | | | | | | | | | | | | | | | | | | | | | | | | | | | | | | |
| 1000 | The conversion result is sent to Decimation Filter blocks A and E. | | | | | | | | | | | | | | | | | | | | | | | | | | | | | | | | | | |
| 1001 | The conversion result is sent to Decimation Filter blocks B and E. | | | | | | | | | | | | | | | | | | | | | | | | | | | | | | | | | | |
| 1010 | The conversion result is sent to Decimation Filter blocks C and E. | | | | | | | | | | | | | | | | | | | | | | | | | | | | | | | | | | |
| 1011 | The conversion result is sent to Decimation Filter blocks D and E. | | | | | | | | | | | | | | | | | | | | | | | | | | | | | | | | | | |
| 1100 | The conversion result is sent to Decimation Filter blocks A and G. | | | | | | | | | | | | | | | | | | | | | | | | | | | | | | | | | | |
| 1101 | The conversion result is sent to Decimation Filter blocks B and G. | | | | | | | | | | | | | | | | | | | | | | | | | | | | | | | | | | |
| 1110 | The conversion result is sent to Decimation Filter blocks C and G. | | | | | | | | | | | | | | | | | | | | | | | | | | | | | | | | | | |
| 1111 | The conversion result is sent to Decimation Filter blocks D and G. | | | | | | | | | | | | | | | | | | | | | | | | | | | | | | | | | | |

Table 27-28. ADC_ACR1-8 Field Descriptions (continued)

| Field | Description |
|-------------------|--|
| 6 FMTA | Conversion Data Format for Alternate Configuration. If the DEST field is not 0b000, the FMTA bit specifies how the 12-bit conversion data returned by the ADCs is formatted into the 16-bit data which is sent to the parallel side interface. 0 Right justified unsigned 1 Right justified signed |
| 7 | Reserved |
| 8–9 RESSEL | ADC Resolution Selection. 00 ADC set to 12-bits resolution 01 ADC set to 10-bits resolution 10 ADC set to 8-bits resolution 11 Reserved |
| 10–13 | Reserved |
| 14–15 PRE_GAIN | ADC Pre-gain control. The PRE_GAIN[0:1] controls the gain of the ADC input stage by changing the internal ADC iterations in the gain stage. 00 X1 gain 01 X2 gain 10 X4 gain 11 Reserved |

27.6.3.7 ADC0/1 Alternate Gain Registers (ADC0_AGR1-2 and ADC1_AGR1-2)

The Alternate Gain Registers (ADC0_AGR_x and ADC1_AGR_x, x=1-2) contain the gain calibration constants used to fine-tune the ADCs conversion results for alternate configurations 1 or 2. A conversion from an ADC uses the corresponding ADC0_AGR_x or ADC1_AGR_x register when the conversion command (with the alternate configuration format) is written to an address in the range 0x08-0x09 of the on-chip ADC memory map. Refer to [Section 27.7.6.6, ADC Calibration Feature](#), for details about the calibration scheme used in the EQADC.

ADC0 Register Address: 0x31, 0x35

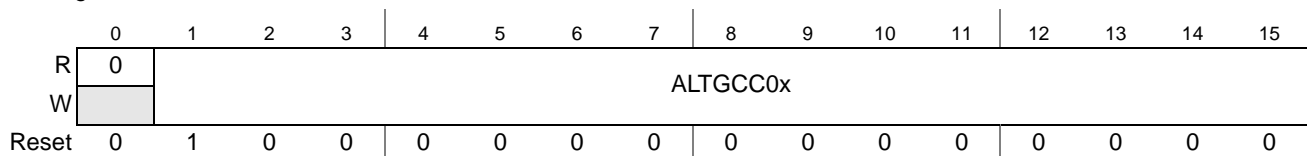

ADC1 Register Address: 0x31, 0x35

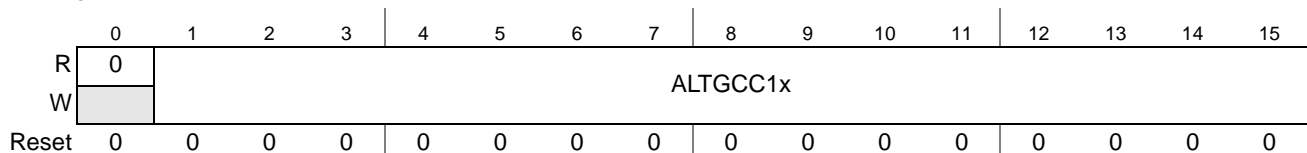

Figure 27-39. ADC0/1 Alternate x Gain Register (ADC0/1_AGR_x, x=1-2)

Table 27-29. ADC0/1_AGRx Field Descriptions

| Field | Description |
|--------------------|---|
| 0 | Reserved |
| 1–15 ALTGCC0/1x | Alternate Gain Calibration Constant. ALTGCC0/1x[0:14] contain the gain calibration constants used to fine-tune ADC0/1 conversion results for alternate configurations 1 and 2. The gain calibration constants are 15-bit unsigned fixed point numbers expressed in the GCC_INT.GCC_FRAC binary format. The integer part of the gain constants (GCC_INT) contain a single binary digit while their fractional part (GCC_FRAC) contain fourteen digits. For details about the GCC data format refer to Section 27.7.6.6.2, MAC Unit and Operand Data Format . |

27.6.3.8 ADC0/1 Alternate Offset Register (ADC0_AOR1-2 and ADC1_AOR1-2)

The Alternate Offset Registers (ADC0_AORx and ADC1_AORx, x=1-2) contain the offset calibration constants used to fine-tune ADCs conversion results for alternate configurations 1 and 2. The offset constants are signed 14-bit integer values. Refer to [Section 27.7.6.6, ADC Calibration Feature](#), for details about the calibration scheme used in the EQADC.

ADC0 Register Address: 0x32, 0x36

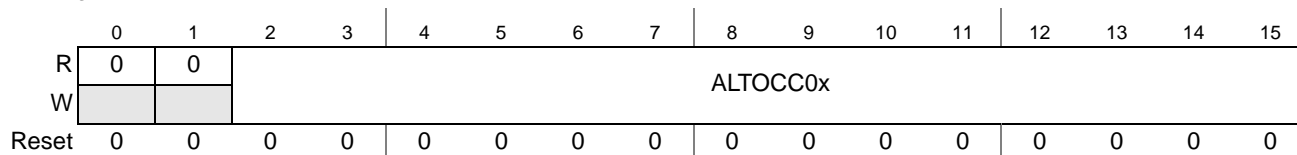

ADC1 Register Address: 0x31, 0x35

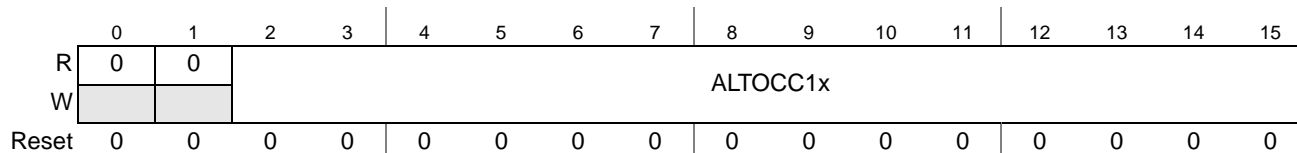

Figure 27-40. ADC0/1 Alternate x Offset Registers (ADC0/1_AORx, x=1-2)

Table 27-30. ADC0/1_AORx Field Descriptions

| Field | Description |
|--------------------|--|
| 0–1 | Reserved |
| 2–15 ALTOCC0/1x | Alternate Offset Calibration Constant. ALTOCC0/1x[0:13] contain the offset calibration constants used to fine-tune ADCs conversion results for alternate configurations 1 or 2. Negative values should be expressed using the two's complement representation. |

27.6.3.9 ADC Pull Up/Down Control Register x (ADC_PUDCRx, x=0-7)

The ADC Pull Up/Down Control Register x (ADC_PUDCRx) contains configuration bits for pull up and pull down resistors present at ADC input channels x, x=0 to 7.

ADC0/1 Register Address: 0x70–0x77

Access: User read/write

| | | | | | | | | | | | | | | | | |
|-------|---|---|----------|---|---|---|-----------|---|---|---|----|----|----|----|----|----|
| | 0 | 1 | 2 | 3 | 4 | 5 | 6 | 7 | 8 | 9 | 10 | 11 | 12 | 13 | 14 | 15 |
| R | 0 | 0 | CH_PULLx | | 0 | 0 | PULL_STRx | | 0 | 0 | 0 | 0 | 0 | 0 | 0 | 0 |
| W | | | | | | | | | | | | | | | | |
| Reset | 0 | 0 | 0 | 0 | 0 | 0 | 0 | 0 | 0 | 0 | 0 | 0 | 0 | 0 | 0 | 0 |

Figure 27-41. ADC Pull Up/Down Control Register x (ADC_PUDCRx, x=0-7)

Table 27-31. ADC_PUDCRx Field Descriptions

| Field | Description |
|------------------|--|
| 0–1 | Reserved |
| 2–3 CH_PULLx | Channel x Pull Up/Down Control bits. The CH_PULLx[0:1] field controls the pull up/down configuration of the channel x. 00 No Pull resistors connected to the channel 01 Pull Up resistor connected to the channel 10 Pull Down resistor connected to the channel 11 Pull Up and Pull Down resistors connected to the channel |
| 4–5 | Reserved |
| 6–7 PULL_STRx | Pull Up/Down Strength Control bits of channel x. The PULL_STRx[0:1] bit field defines the strength of the channel x pull up or down resistors. 00 Reserved 01 200 Kohm pull resistor 10 100 Kohm pull resistor 11 5 Kohm (approx.) pull resistor (not available for CH_PULL_x = 0b11) |
| 8–15 | Reserved |

27.7 Functional Description

27.7.1 Overview

The EQADC provides a parallel interface to two on-chip ADCs and a parallel side interface to an on-chip companion module, like a decimation filter. The two on-chip ADCs are architected to allow access to all the analog channels.

Initially, command data is contained in system memory in a user defined data structure which is likely to be a queue as depicted in [Figure 27-2](#)¹. Command data is moved between the CQueues and CFIFOs by the host CPU or by the DMAC which respond to interrupt and DMA requests generated by the EQADC. The EQADC supports software and hardware triggers from other blocks or external pins to initiate transfers of commands from the multiple CFIFOs to the on-chip ADCs.

1. Command and result data can be stored in the system memory in any user defined data structure. However, in this document it will be assumed that the data structure of choice is a queue, since it is the most likely data structure to be used and because queues are the only type of data structure supported by the DMAC.

CFIFOs can be configured in single-scan or continuous-scan mode. When a CFIFO is configured in single-scan mode, the EQADC scans the CQueue one time. The EQADC stops transferring commands from the triggered CFIFO after detecting the EOQ bit set in the last transfer. After an EOQ bit is detected, software involvement is required to rearm the CFIFO so that it can detect new trigger events.

When a CFIFO is configured for continuous-scan mode, the whole CQueue is scanned multiple times. After the detection of an asserted EOQ bit in the last command transfer, command transfers can continue or not depending on the mode of operation of the CFIFO.

CFIFO0 has a special configuration option to allow a repetitive sequence of conversion commands (streaming mode) with high priority characteristics (abort operation) or not. This feature is useful with the immediate conversion command feature that allows the immediate execution of a conversion command or a sequence of commands with critical timing even with the possibility of abortion of some current ADC conversion in progress. The aborted command is stored and executed again as soon as the critical timing commands have been finished.

The multiple Result FIFOs (RFIFOs) can receive data from the on-chip ADCs or from an on-chip companion module (decimation filter). Data from the on-chip ADCs can be routed to the side interface, processed by the on-chip companion module (decimation filter) and then routed back through the side interface to the RFIFOs.

27.7.2 Data Flow in EQADC

27.7.2.1 Overview and Basic Terminology

Figure 27-42 shows how command data flows inside the EQADC system. A Command Message is the predefined format at which command data is stored in the CQueues. A Command message has 32 bits and is composed of two parts: a CFIFO header and an ADC Command. Command messages are moved from the CQueues to the CFIFOs by the host CPU or by the DMAC as they respond to interrupt and DMA requests generated by the EQADC. The EQADC generates these requests whenever a CFIFO is not full. The *FIFO Control Unit* will only transfer to a CBuffer the ADC command part of the Command Message. Information in the CFIFO header together with the upper bit of the ADC command is used by the *FIFO Control Unit* to arbitrate which triggered CFIFO will be transferring the next command.

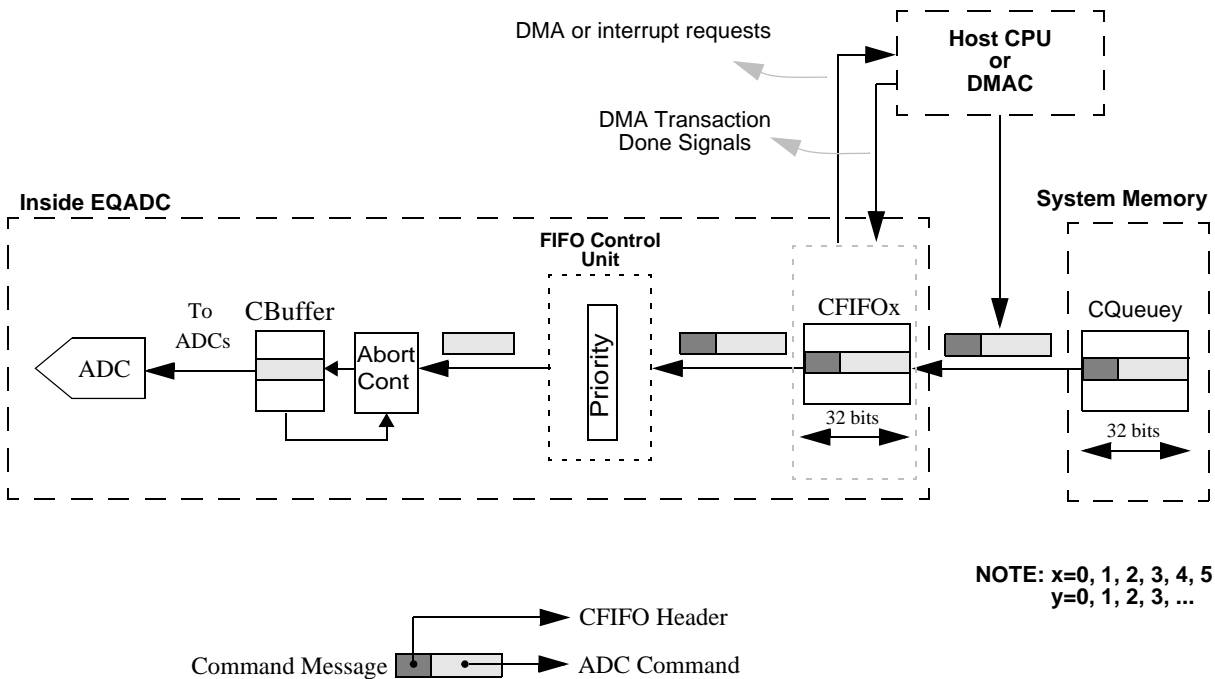

Figure 27-42. Command Flow during EQADC operation

ADC commands sent to the on-chip CBuffers are executed in a first-in-first-out basis with exception when the immediate conversion command function is enabled. Three types of results can be expected: data read from an ADC register, a conversion result, or a time stamp.

NOTE

While the EQADC pops commands out from a CFIFO, it also is checking the number of entries in the CFIFO and generating requests to fill it. The process of pushing and popping commands to and from a CFIFO can occur simultaneously. However, this is not true for CFIFO0 when configured to operate in streaming mode for popping.

The *FIFO Control Unit* expects all incoming results to be shaped in a predefined Result Message format. [Figure 27-43](#) shows how result data flows inside the EQADC system. Results generated on the on-chip ADCs are adjusted considering the selected resolution of the ADC and are formatted into result messages inside the *Result Format and Calibration Sub-Block*. This result message can be routed directly to one of the RFIFOs or to an on-chip companion module (decimation filter) via the parallel side interface. After the data is processed by the companion module, it can be routed back to one of the RFIFOs via the side interface with the correct format. A result message is composed of an RFIFO header and an ADC Result. The *FIFO Control Unit* decodes the information contained in the RFIFO header to determine the RFIFO to which the ADC result should be sent. Once in an RFIFO, the ADC result is moved to the corresponding RQueue by the host CPU or by the DMAC as they respond to interrupt and DMA requests generated by the EQADC. The EQADC generates these requests whenever an RFIFO has at least one entry.

NOTE

While conversion results are returned, the EQADC is checking the number of entries in the RFIFO and generating requests to empty it. The process of pushing and popping ADC results to and from an RFIFO can occur simultaneously.

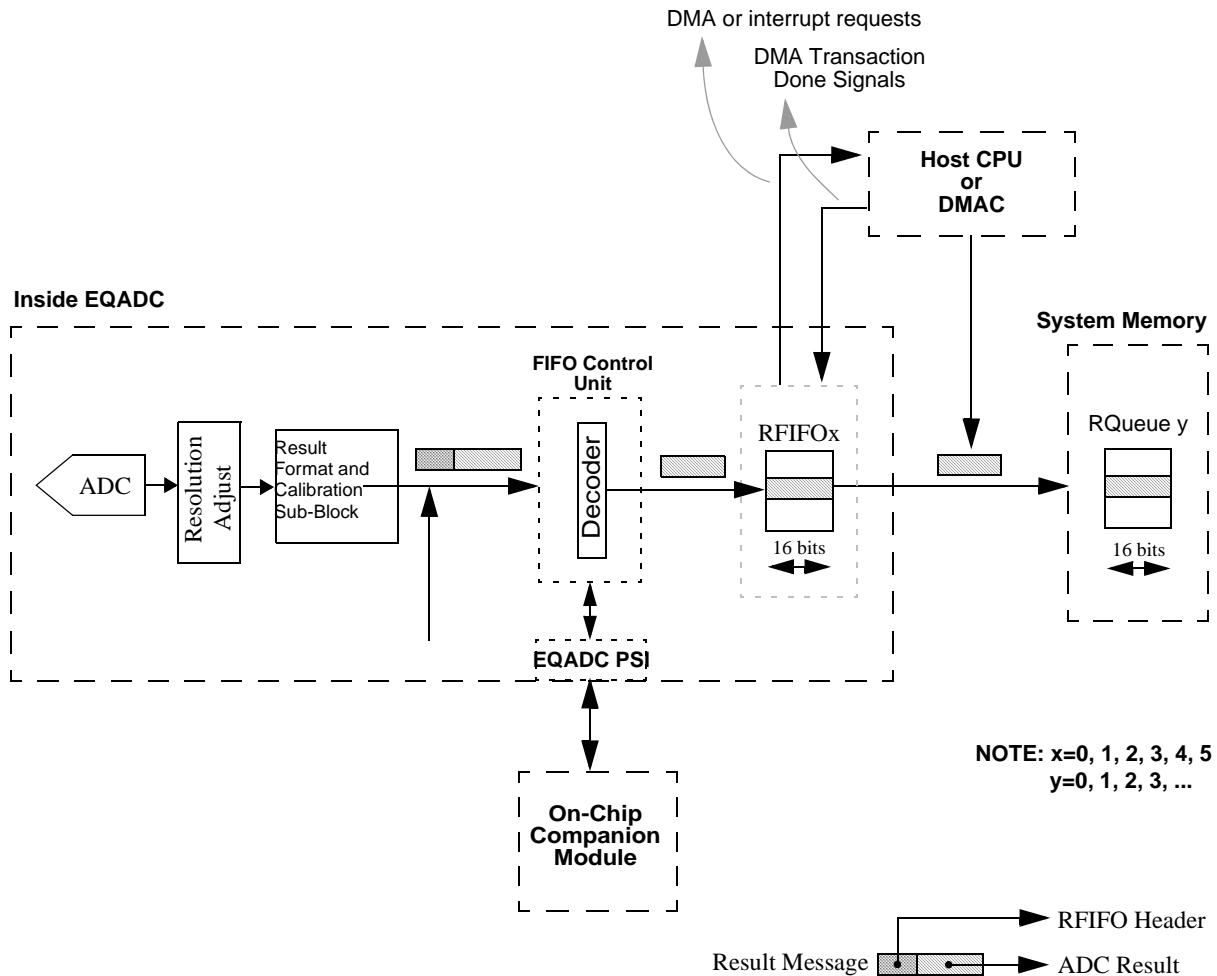

Figure 27-43. Result Flow during EQADC operation

27.7.2.2 Message Format in EQADC

This section explains the command and result message formats used for on-chip ADC operation.

A Command Message is the predefined format at which command data is stored in the cqueues. A Command message has 32 bits and is composed of two parts: a CFIFO header and an ADC Command. The size of the CFIFO header is fixed to 6 bits, and it works as inputs to the *FIFO Control Unit*. It controls when a CQueue ends, when it pauses, when a loop starts (only for CFIFO0 in streaming mode), if commands are sent to internal or external buffers, and if it can abort a serial data transmission. Information contained in the CFIFO header, together with the upper bit of the ADC Command is used by the *FIFO*

Control Unit to arbitrate which triggered CFIFO will transfer the next command. ADC commands are encoded inside the least significant 26 bits of the command message.

A Result message is composed of an RFIFO header and an ADC Result. The *FIFO Control Unit* decodes the information contained in the RFIFO header to determine the RFIFO to which the ADC result should be sent. An ADC result is always 16 bits long.

27.7.2.2.1 Message Formats for On-Chip ADC Operation

This section describes the Command/Result message formats used for on-chip ADC operation.

Conversion Command Format for the Standard Configuration

Figure describes the format for conversion commands when interfacing with the on-chip ADCs in the standard configuration. The standard configuration is selected when the least significant byte (bits 24-31) of the conversion command is set to zero. In the standard configuration, the conversion result is always routed to one of the RFIFOs. A time stamp information can be optionally requested.

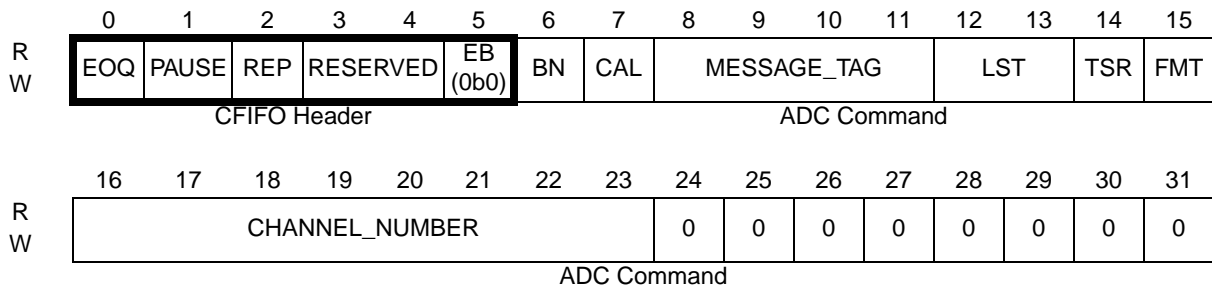

Conversion Command Format for the Standard Configuration

Table 27-32. Field Descriptions

| Field | Description |
|------------|--|
| 0 EOQ | <p>End Of Queue Bit. The EOQ bit is asserted in the last command of a CQueue to indicate to the EQADC that a scan of the CQueue is completed. EOQ instructs the EQADC to reset its current CFIFO transfer counter value (TC_CF) to zero. Depending on the CFIFO mode of operation, the CFIFO status will also change upon the detection of an asserted EOQ bit on the last transferred command - see Section 27.7.4.6, CFIFO Scan Trigger Modes, for details.</p> <p>0 Not the last entry of the CQueue. 1 Last entry of the CQueue.</p> <p>Note: If both the PAUSE and EOQ bits are asserted in the same command message the respective flags are set, but the CFIFO status changes as if only the EOQ bit were asserted.</p> |
| 1 PAUSE | <p>Pause Bit. The Pause bit allows software to create sub-queues within a CQueue. When the EQADC completes the transfer of a command with an asserted Pause bit, the CFIFO enters the WAITING FOR TRIGGER state. Refer to Section 27.7.4.7.1, CFIFO Operation Status, for a description of the state transitions. The Pause bit is only valid when CFIFO operation mode is configured to single or continuous-scan edge trigger mode.</p> <p>0 Do not enter WAITING FOR TRIGGER state after transfer of the current Command Message. 1 Enter WAITING FOR TRIGGER state after transfer of the current Command Message.</p> <p>Note: If both the PAUSE and EOQ bits are asserted in the same command message the respective flags are set, but the CFIFO status changes as if only the EOQ bit were asserted.</p> |

Table 27-32. Field Descriptions (continued)

| Field | Description | | | | | | | | | | |
|---------------------|--|----------|---------------------------------------|------|---|------|---|------|----|------|-----|
| 2 REP | Repeat/loop Start Point Indication Bit. The REP bit is asserted in the command to indicate where is the start point of the sub-queue to be repeated when the streaming mode is enabled. The PAUSE bit indicates the end point of the sub-queue. Therefore, both can occur in the same command or in separated ones. If two or more REP bits are read before a PAUSE bit, this is an error case and the intermediary REP bits are ignored. 0 It is not the start point of a loop. 1 Indicates the start point of the sub-queue to be repeated. | | | | | | | | | | |
| 3–4 | Reserved | | | | | | | | | | |
| 5 EB | External Buffer Bit. A negated EB bit indicates that the command is sent to an internal CBuffer. 0 Command is sent to an internal buffer. 1 Reserved. | | | | | | | | | | |
| 6 BN | Buffer Number Bit. BN indicates which buffer the message will be stored in. 1 Message stored in buffer 1. 0 Message stored in buffer 0. | | | | | | | | | | |
| 7 CAL | Calibration Bit. CAL indicates if the returning conversion result must be calibrated. 1 Calibrate conversion result. 0 Do not calibrate conversion result. | | | | | | | | | | |
| 8–11 MESSAGE_TAG | MESSAGE_TAG Field. The MESSAGE_TAG allows the EQADC to separate returning results into different RFIFOs. When the EQADC transfers a command, the MESSAGE_TAG is included as part of the command. Eventually the on-chip ADC returns the result with the same MESSAGE_TAG. The EQADC separates incoming messages into different RFIFOs by decoding the MESSAGE_TAG of the incoming data. 0000 Result is sent to RFIFO 0 0001 Result is sent to RFIFO 1 0010 Result is sent to RFIFO 2 0011 Result is sent to RFIFO 3 0100 Result is sent to RFIFO 4 0101 Result is sent to RFIFO 5 0110–0111 Reserved 1000 Null Message Received 1001 Reserved for customer use (see note) 1010 Reserved for customer use (see note) 1011–1111 Reserved Note: These messages are treated as null messages. | | | | | | | | | | |
| 12–13 LST | Long Sampling Time. These two bits determine the duration of the sampling time in ADC clock cycles. <table border="1" style="margin-left: auto; margin-right: auto;"> <thead> <tr> <th>LST[0:1]</th> <th>Sampling cycles (ADC Clock Cycles)</th> </tr> </thead> <tbody> <tr> <td>0b00</td> <td>2</td> </tr> <tr> <td>0b01</td> <td>8</td> </tr> <tr> <td>0b10</td> <td>64</td> </tr> <tr> <td>0b11</td> <td>128</td> </tr> </tbody> </table> | LST[0:1] | Sampling cycles (ADC Clock Cycles) | 0b00 | 2 | 0b01 | 8 | 0b10 | 64 | 0b11 | 128 |
| LST[0:1] | Sampling cycles (ADC Clock Cycles) | | | | | | | | | | |
| 0b00 | 2 | | | | | | | | | | |
| 0b01 | 8 | | | | | | | | | | |
| 0b10 | 64 | | | | | | | | | | |
| 0b11 | 128 | | | | | | | | | | |

Table 27-32. Field Descriptions (continued)

| Field | Description |
|--------------------------|--|
| 14 TSR | Time Stamp Request. TSR indicates the request for a time stamp. When TSR is asserted, the on-chip <i>ADC Control Logic</i> returns a time stamp for the current conversion command after the conversion result is sent to the RFIFOs. See Section 27.7.6.3, Time Stamp Feature , for details. 0 Return conversion result only. 1 Return conversion time stamp after the conversion result. |
| 15 FMT | Conversion Data Format. FMT specifies to the EQADC how to format the 12-bit conversion data returned by the ADCs into the 16-bit format which is sent to the RFIFOs. See Section , ADC Result Format for On-Chip ADC Operation , for details. 0 Right justified unsigned. 1 Right justified signed. |
| 16–23 CHANNEL_ NUMBER | Channel Number Field. The CHANNEL_NUMBER field selects the analog input channel. The software programs this field with the channel number corresponding to the analog input pin to be sampled and converted. See Section 27.7.7.1, Channel Assignment , for details. |
| 24–31 | Reserved |

Conversion Command Format for Alternate Configurations

Figure 27-44 describes the format for conversion commands when interfacing with the on-chip ADCs in one of the 8 alternate configurations. An alternate configuration is selected when the least significant byte (bits 24–31) of the conversion command is set to a value in the range 0x08–0x0F. Each value in this range selects one of the 8 alternate configuration (0x08 selects Alternate Configuration 1, 0x0F selects Alternate Configuration 8). In the alternate configurations, the conversion result can be routed to one of the RFIFOs or to the parallel side interface to communicate with an on-chip companion module (decimation filter). A bit field in the corresponding Alternate Configuration Control Register selects the Internal RFIFO or Parallel Side Interface as the destination for the conversion result. Time stamp information can be optionally requested.

NOTE

All fields, except FFMT and ALT_CONFIG_SEL, are identical to the ones in the standard configuration format. Only the fields which are different from the standard format will be described here.

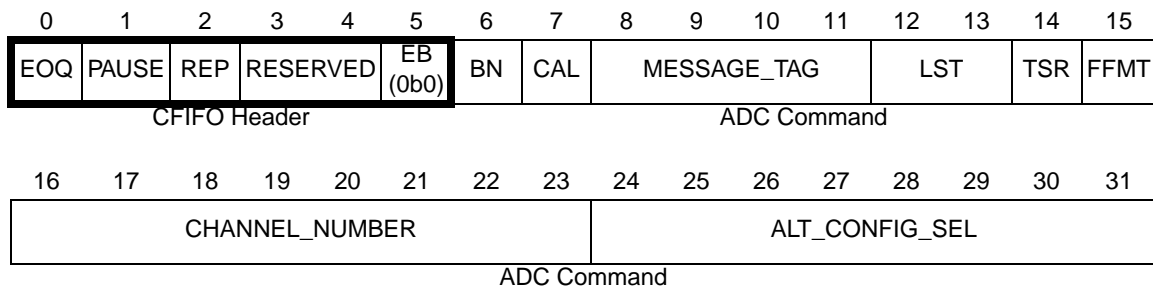

Figure 27-44. Conversion Command Format for Alternate Configurations

Table 27-33. Field Descriptions

| Field | Description |
|------------|--|
| 0 EOQ | <p>End Of Queue Bit. The EOQ bit is asserted in the last command of a CQueue to indicate to the EQADC that a scan of the CQueue is completed. EOQ instructs the EQADC to reset its current CFIFO transfer counter value (TC_CF) to zero. Depending on the CFIFO mode of operation, the CFIFO status will also change upon the detection of an asserted EOQ bit on the last transferred command - see Section 27.7.4.6, CFIFO Scan Trigger Modes, for details.</p> <p>0 Not the last entry of the CQueue. 1 Last entry of the CQueue.</p> <p>Note: If both the PAUSE and EOQ bits are asserted in the same command message the respective flags are set, but the CFIFO status changes as if only the EOQ bit were asserted.</p> |
| 1 PAUSE | <p>Pause Bit. The Pause bit allows software to create sub-queues within a CQueue. When the EQADC completes the transfer of a command with an asserted Pause bit, the CFIFO enters the WAITING FOR TRIGGER state. Refer to Section 27.7.4.7.1, CFIFO Operation Status, for a description of the state transitions. The Pause bit is only valid when CFIFO operation mode is configured to single or continuous-scan edge trigger mode.</p> <p>0 Do not enter WAITING FOR TRIGGER state after transfer of the current Command Message. 1 Enter WAITING FOR TRIGGER state after transfer of the current Command Message.</p> <p>Note: If both the PAUSE and EOQ bits are asserted in the same command message the respective flags are set, but the CFIFO status changes as if only the EOQ bit were asserted.</p> |
| 2 REP | <p>Repeat/loop Start Point Indication Bit. The REP bit is asserted in the command to indicate where is the start point of the sub-queue to be repeated when the streaming mode is enabled. The PAUSE bit indicates the end point of the sub-queue. Therefore, both can occur in the same command or in separated ones. If two or more REP bits are read before a PAUSE bit, this is an error case and the intermediary REP bits are ignored.</p> <p>0 It is not the start point of a loop. 1 Indicates the start point of the sub-queue to be repeated.</p> |
| 3–4 | Reserved |
| 5 EB | <p>External Buffer Bit. A negated EB bit indicates that the command is sent to an internal CBuffer.</p> <p>0 Command is sent to an internal buffer. 1 Reserved.</p> |
| 6 BN | <p>Buffer Number Bit. BN indicates which buffer the message will be stored in.</p> <p>1 Message stored in buffer 1. 0 Message stored in buffer 0.</p> |
| 7 CAL | <p>Calibration Bit. CAL indicates if the returning conversion result must be calibrated.</p> <p>1 Calibrate conversion result. 0 Do not calibrate conversion result.</p> |

Table 27-33. Field Descriptions (continued)

| Field | Description | | | | | | | | | | |
|---------------------|---|----------|---------------------------------------|------|---|------|---|------|----|------|-----|
| 8–11 MESSAGE_TAG | <p>MESSAGE_TAG Field. The MESSAGE_TAG allows the EQADC to separate returning results into different RFIFOs. When the EQADC transfers a command, the MESSAGE_TAG is included as part of the command. Eventually the on-chip ADC returns the result with the same MESSAGE_TAG. The EQADC separates incoming messages into different RFIFOs by decoding the MESSAGE_TAG of the incoming data.</p> <p>0000 Result is sent to RFIFO 0 0001 Result is sent to RFIFO 1 0010 Result is sent to RFIFO 2 0011 Result is sent to RFIFO 3 0100 Result is sent to RFIFO 4 0101 Result is sent to RFIFO 5 0110–0111 Reserved 1000 Null Message Received 1001 Reserved for customer use (see note) 1010 Reserved for customer use (see note) 1011–1111 Reserved</p> <p>Note: These messages are treated as null messages.</p> | | | | | | | | | | |
| 12–13 LST | <p>Long Sampling Time. These two bits determine the duration of the sampling time in ADC clock cycles.</p> <table border="1" style="margin-left: auto; margin-right: auto;"> <thead> <tr> <th>LST[0:1]</th> <th>Sampling cycles (ADC Clock Cycles)</th> </tr> </thead> <tbody> <tr> <td>0b00</td> <td>2</td> </tr> <tr> <td>0b01</td> <td>8</td> </tr> <tr> <td>0b10</td> <td>64</td> </tr> <tr> <td>0b11</td> <td>128</td> </tr> </tbody> </table> | LST[0:1] | Sampling cycles (ADC Clock Cycles) | 0b00 | 2 | 0b01 | 8 | 0b10 | 64 | 0b11 | 128 |
| LST[0:1] | Sampling cycles (ADC Clock Cycles) | | | | | | | | | | |
| 0b00 | 2 | | | | | | | | | | |
| 0b01 | 8 | | | | | | | | | | |
| 0b10 | 64 | | | | | | | | | | |
| 0b11 | 128 | | | | | | | | | | |
| 14 TSR | <p>Time Stamp Request. TSR indicates the request for a time stamp. When TSR is asserted, the on-chip <i>ADC Control Logic</i> returns a time stamp for the current conversion command after the conversion result is sent to the RFIFOs. See Section 27.7.6.3, Time Stamp Feature, for details.</p> <p>0 Return conversion result only. 1 Return conversion time stamp after the conversion result.</p> | | | | | | | | | | |
| 15 FFMT | <p>Conversion Data Format. FMT specifies to the EQADC how to format the 12-bit conversion data returned by the ADCs into the 16-bit format which is sent to the RFIFOs. See Section , ADC Result Format for On-Chip ADC Operation, for details.</p> <p>0 Right justified unsigned. 1 Right justified signed.</p> | | | | | | | | | | |

Table 27-33. Field Descriptions (continued)

| Field | Description | | | | | | | | | | | | | | | | | | |
|-------------------------|--|---------------------|-------------------------|------|---|------|---|------|---|------|---|------|---|------|---|------|---|------|---|
| 16–23 CHANNEL_NUMBER | Channel Number Field. The CHANNEL_NUMBER field selects the analog input channel. The software programs this field with the channel number corresponding to the analog input pin to be sampled and converted. See Section 27.7.7.1, Channel Assignment , for details. | | | | | | | | | | | | | | | | | | |
| 24–31 ALT_CONFIG_SEL | Alternate Configuration Selection. This field selects one of the alternate configurations. <table border="1" style="margin-left: auto; margin-right: auto;"> <thead> <tr> <th>ALT_CONFIG_SEL[0:7]</th> <th>Alternate Configuration</th> </tr> </thead> <tbody> <tr><td>0x08</td><td>1</td></tr> <tr><td>0x09</td><td>2</td></tr> <tr><td>0x0A</td><td>3</td></tr> <tr><td>0x0B</td><td>4</td></tr> <tr><td>0x0C</td><td>5</td></tr> <tr><td>0x0D</td><td>6</td></tr> <tr><td>0x0E</td><td>7</td></tr> <tr><td>0x0F</td><td>8</td></tr> </tbody> </table> | ALT_CONFIG_SEL[0:7] | Alternate Configuration | 0x08 | 1 | 0x09 | 2 | 0x0A | 3 | 0x0B | 4 | 0x0C | 5 | 0x0D | 6 | 0x0E | 7 | 0x0F | 8 |
| ALT_CONFIG_SEL[0:7] | Alternate Configuration | | | | | | | | | | | | | | | | | | |
| 0x08 | 1 | | | | | | | | | | | | | | | | | | |
| 0x09 | 2 | | | | | | | | | | | | | | | | | | |
| 0x0A | 3 | | | | | | | | | | | | | | | | | | |
| 0x0B | 4 | | | | | | | | | | | | | | | | | | |
| 0x0C | 5 | | | | | | | | | | | | | | | | | | |
| 0x0D | 6 | | | | | | | | | | | | | | | | | | |
| 0x0E | 7 | | | | | | | | | | | | | | | | | | |
| 0x0F | 8 | | | | | | | | | | | | | | | | | | |

Write Configuration Command Format for On-Chip ADC Operation

Figure 27-45 describes the command message format for a write configuration command when interfacing with the on-chip ADCs. A write configuration command is used to set the control registers of the on-chip ADCs. No conversion data will be returned for a write configuration command. Write configuration commands are differentiated from read configuration commands by a negated R/W bit.

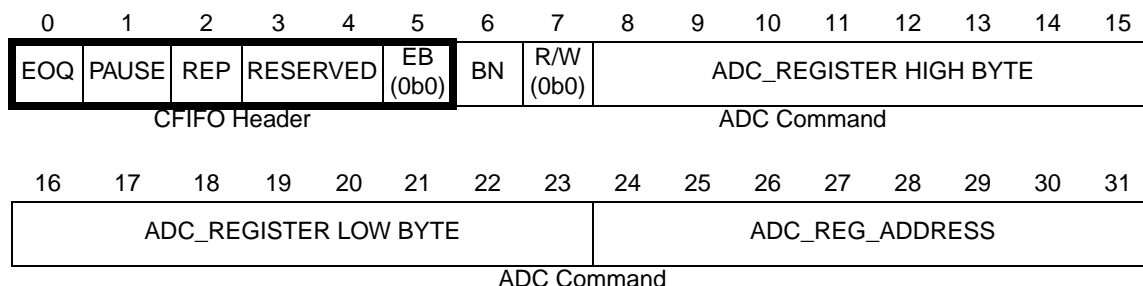

Figure 27-45. Write Configuration Command Format for On-Chip ADC Operation

Table 27-34. Field Descriptions

| Field | Description |
|---------------------------------|--|
| 0 EOQ | End Of Queue Bit |
| 1 PAUSE | Pause Bit |
| 2 REP | Repeat/loop Start Point Indication Bit |
| 3–4 | Reserved |
| 5 EB | Must be 0b0 |
| 6 BN | Buffer Number Bit. Refer to Section , Conversion Command Format for the Standard Configuration. |
| 7 R/W | Read/Write bit. A negated R/W indicates a write configuration command. 0 Write 1 Read |
| 8–15 ADC_REGISTER_ HIGH_BYTE | ADC Register High Byte Field. REGISTER_HIGH_BYTE is the value to be written into the most significant 8 bits of control/configuration register when the R/W bit is negated. |
| 16–23 ADC_REGISTER_ LOW_BYTE | ADC Register Low Byte Field. REGISTER_LOW_BYTE is the value to be written into the least significant 8 bits of a control/configuration register when the R/W bit is negated. |
| 24–31 ADC_REG_ ADDRESS | ADC Register Address. The ADC_REG_ADDRESS field selects a register on the ADC register set to be written or read. Only half-word addresses can be used. |

Read Configuration Command Format for On-Chip ADC Operation

Figure 27-46 describes the command message format for a read configuration command when interfacing with the on-chip ADCs. A read configuration command is used to read the contents of the on-chip ADC registers which are only accessible via command messages. Read configuration commands are differentiated from write configuration commands by an asserted R/W bit.

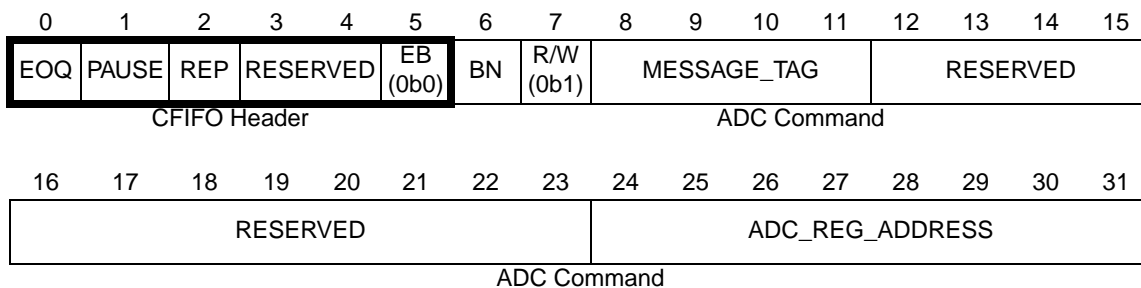

Figure 27-46. Read Configuration Command Format for On-Chip ADC Operation

Table 27-35. Field Descriptions

| Field | Description |
|------------------------------|---|
| 0 EOQ | End Of Queue Bit |
| 1 PAUSE | Pause Bit |
| 2 REP | Repeat/loop Start Point Indication Bit |
| 3–4 | Reserved |
| 5 EB | Must be 0b0 |
| 6 BN | Buffer Number Bit. Refer to Section , Conversion Command Format for the Standard Configuration . |
| 7 R/W | Read/Write bit. An asserted R/W bit indicates a read configuration command. 0 Write1Read |
| 8–11 MESSAGE_ TAG | MESSAGE_TAG Field. Refer to Section , Conversion Command Format for the Standard Configuration . |
| 12–23 | Reserved |
| 24–31 ADC_REG_ ADDRESS | ADC Register Address. The ADC_REG_ADDRESS field selects a register on the ADC register set to be written or read. Only half-word addresses can be used. |

ADC Result Format for On-Chip ADC Operation

When the *FIFO Control Unit* receives a return data message, it decodes the MESSAGE_TAG field and stores the 16-bit data into the appropriate RFIFO. This section describes the *ADC result* portion of the *result message* returned by the on-chip ADCs. The 16-bit data stored in the RFIFOs can be:

- Data read from an ADC register with a read configuration command. In this case, the stored 16-bit data corresponds to the contents of the ADC register that was read.
- A time stamp. In this case, the stored 16-bit data is the value of the time base counter latched when the EQADC detects the end of the analog input voltage sampling. For details see [Section 27.7.6.3, Time Stamp Feature](#).
- A conversion result, coming directly from the ADCs. In this case, the stored 16-bit data contains a right justified 14-bit result data. The conversion result can be calibrated or not depending on the status of CAL bit in the command that requested the conversion¹. When the CAL bit is negated, this 14-bit data is obtained by executing a 2-bit left-shift on the 12-bit data resultant from the resolution adjustment on the 8 or 10 or 12-bit data received from the ADC. The resolution adjustment consists of changing the conversion result input from 8, 10 or 12 bits right aligned to a 12-bit word left aligned - refer to [Section 27.7.6.5, ADC Resolution Selection Feature](#), for details. When the CAL bit is asserted, this 14-bit data is the result of the calculations performed in the

1. In case the conversion result is routed through an on-chip DSP via side interface, the calibration is applied before the data is sent to the DSP.

EQADC MAC unit using the 12-bit data result of the resolution adjustment and the calibration constants GCC and OCC, or ALTGCC and ALTOCC - refer to [Section 27.7.6.6, ADC Calibration Feature](#), for details. Then, this 14-bit data is further formatted into a 16-bit format according to the status of the FMT bit in conversion command of the standard configuration or FFMT bit in the conversion command of the alternate configurations¹. When FMT/FFMT is asserted, the 14-bit result data is reformatted to look as if it was measured against an imaginary ground at VREF/2 (the MSB bit of the 14-bit result is inverted), and is sign-extended to a 16-bit format as in [Figure 27-47](#). When FMT/FFMT is negated, the EQADC zero-extends the 14-bit result data to a 16-bit format as in [Figure 27-48](#). Correspondence between the analog voltage in a channel and the calculated digital values is shown in [Table 27-37](#).

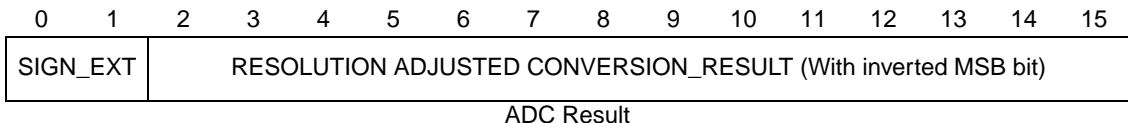

Figure 27-47. ADC Result Format when FMT=1 (Right Justified Signed)

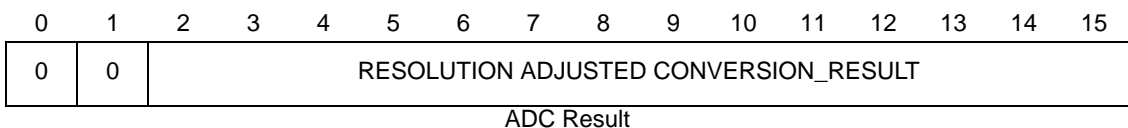

Figure 27-48. ADC Result Format when FMT=0 (Right Justified Unsigned)

1. For simplicity, the following text will refer to FMT only, but when using alternate configurations, refer to [Conversion Command Format for Alternate Configurations](#).

Table 27-36. Field Descriptions

| Field | Description |
|---------------------------|---|
| 0–1 SIGN_EXT | Sign Extension field. SIGN_EXT only has meaning when FMT is asserted. SIGN_EXT is 0b00 when CONVERSION_RESULT is positive, and 0b11 when CONVERSION_RESULT is negative. |
| 2–15 CONVERSION_RESULT | Conversion Result field. CONVERSION_RESULT is a digital value corresponding to the analog input voltage in a channel when the conversion command was initiated. The two's complement representation is used to express negative values. |

Table 27-37. Correspondence between analog voltages and digital values^{1, 2}

| | Voltage Level on Channel (V) | Corresponding 8-bit Conversion Result Returned by the ADC ³ | Corresponding 10-bit Conversion Result Returned by the ADC ⁴ | Corresponding 12-bit Conversion Result Returned by the ADC ⁵ | 16-bit Result Sent to RFIFOs (FMT=0) ⁶ | 16-bit Result Sent to RFIFOs (FMT=1) ⁶ |
|--------------------------|------------------------------|--|---|---|---|---|
| Single-Ended Conversions | 5.12 | — | — | 0xFFF | 0x3FFC | 0x1FFC |
| | | — | 0x3FF | — | 0x3FF0 | 0x1FF0 |
| | | 0xFF | — | — | 0x3FC0 | 0x1FC0 |
| | 5.12 – LSB | — | — | 0xFFF | 0x3FFC | 0x1FFC |
| | | — | 0x3FF | — | 0x3FF0 | 0x1FF0 |
| | | 0xFF | — | — | 0x3FC0 | 0x1FC0 |
| | ... | ... | ... | ... | ... | ... |
| | 2.56 | — | — | 0x800 | 0x2000 | 0x0000 |
| | | — | 0x200 | — | 0x2000 | 0x0000 |
| | | 0x80 | — | — | 0x2000 | 0x0000 |
| | ... | ... | ... | ... | ... | ... |
| | 1 LSB | — | — | 0x001 | 0x0004 | 0xE004 |
| — | | 0x001 | — | 0x0010 | 0xE010 | |
| 0x01 | | — | — | 0x0040 | 0xE040 | |
| 0 | 0x00 | 0x000 | 0x000 | 0x0000 | 0xE000 | |
| Differential Conversions | 2.56 | — | — | 0xFFF | 0x3FFC | 0x1FFC |
| | | — | 0x3FF | — | 0x3FF0 | 0x1FF0 |
| | | 0xFF | — | — | 0x3FC0 | 0x1FC0 |
| | 2.56 - LSB | — | — | 0xFFF | 0x3FFC | 0x1FFC |
| | | — | 0x3FF | — | 0x3FF0 | 0x1FF0 |
| | | 0xFF | — | — | 0x3FC0 | 0x1FC0 |
| | ... | ... | ... | ... | ... | ... |
| | 0 | — | — | 0x800 | 0x2000 | 0x0000 |
| | | — | 0x200 | — | 0x2000 | 0x0000 |
| | | 0x80 | — | — | 0x2000 | 0x0000 |
| | ... | ... | ... | ... | ... | ... |
| | 2.56 – LSB | — | — | 0x001 | 0x0004 | 0xE004 |
| | | — | 0x001 | — | 0x0010 | 0xE010 |
| | | 0x01 | — | — | 0x0040 | 0xE040 |
| | -2.56 | 0x00 | 0x000 | 0x000 | 0x0000 | 0xE000 |

NOTES:

- 1 VREF=VRH-VRL=5.12V. Resulting in one 12-bit count (LSB) =1.25mV.
- 2 The two's complement representation is used to express negative values.
- 3 For non-corner voltages (voltages different from V_{RL} and V_{RH}), the maximum quantization error is ± 0.5 LSB. First code transition (from 0x000 to 0x001 for unsigned values) happens at +0.5 LSB (V) while the last one (from 0xFFE to 0xFFF for unsigned values) happens at $V_{REF} - 1.5$ LSB (V).
- 4 For non-corner voltages (voltages different from V_{RL} and V_{RH}), the maximum quantization error is ± 0.5 LSB. First code transition (from 0x000 to 0x001 for unsigned values) happens at +0.5 LSB (V) while the last one (from 0xFFE to 0xFFF for unsigned values) happens at $V_{REF} - 1.5$ LSB (V).
- 5 For non-corner voltages (voltages different from V_{RL} and V_{RH}), the maximum quantization error is ± 0.5 LSB. First code transition (from 0x000 to 0x001 for unsigned values) happens at +0.5 LSB (V) while the last one (from 0xFFE to 0xFFF for unsigned values) happens at $V_{REF} - 1.5$ LSB (V).
- 6 Assuming uncalibrated conversion results.

27.7.3 Command/Result Queues

Each CQueue entry is a 32-bit Command Message. The last entry of a CQueue has the EOQ bit asserted to indicate that it is the last entry of the CQueue. RQueue entry is a 16-bit data.

See [Section 27.7.2.1, Overview and Basic Terminology](#), for a description of the message formats and their flow in EQADC.

Refer to [Section 27.8.5, CQueue and RQueues Usage](#), for examples of how CQueues and RQueues can be used.

27.7.4 EQADC Command FIFOs

27.7.4.1 CFIFO Basic Functionality

There are six prioritized CFIFOs located in the EQADC. Each CFIFO is four entries deep, except CFIFO0 that can be configured to eight entries deep in extended mode, and each CFIFO entry is 32 bits long. A CFIFO serves as a temporary storage location for the command messages stored in the CQueues in the system memory. When a CFIFO is not full, the EQADC sets the corresponding CFFF bit in EQADC_FISR. If CFFE is asserted in EQADC_IDCR, the EQADC generates requests for more commands from a CQueue. An interrupt request, served by the host CPU, is generated when CFFS is negated, and a DMA request, served by the DMAC, is generated when CFFS is asserted. The host CPU or the DMAC respond to these requests by writing to the EQADC_CFPR to fill the CFIFO.

NOTE

The DMAC should be configured to write a single command (32-bit data) to the CFIFO push registers for every asserted DMA request it acknowledges. Refer to [Section 27.8.2, EQADC/DMAC Interface](#), for DMAC configuration guidelines.

NOTE

CFIFO0 can be configured to work in an alternative way called Streaming Mode. This mode is very different from the mode described here because it maintains some stored commands to execute them several times in sequence and in loop.

NOTE

Only whole words must be written to EQADC_CFPR. Writing half-words or bytes to EQADC_CFPR will still push the whole 32-bit CF_PUSH field into the corresponding CFIFO, but undefined data will fill the areas of CF_PUSH that were not specifically designated as target locations for writing.

Figure 27-49 describes the important components in the CFIFO. Each CFIFO is implemented as a circular set of registers to avoid the need to move all entries at each push/pop operation. The Push Next Data Pointer points to the next available CFIFO location for storing data written into the EQADC Command FIFO Push Register. The Transfer Next Data Pointer points to the next entry to be removed from CFIFO_x when it completes a transfer. The *CFIFO Transfer Counter Control Logic* counts the number of entries in the CFIFO and generates DMA or interrupt requests to fill the CFIFO. TNXTPTR in EQADC_FISR, indicates the index of the entry that is currently being addressed by the Transfer Next Data Pointer, and CFCTR, in the same register, provides the number of entries stored in the CFIFO. Using TNXTPTR and CFCTR, the absolute addresses for the entries indicated by the Transfer Next Data Pointer and by the Push Next Data Pointer can be calculated using the following formulas:

$$\text{Transfer Next Data Pointer Address} = \text{CFIFO}_x\text{_BASE_ADDRESS} + \text{TNXTPTR}_x * 4$$

$$\text{Push Next Data Pointer Address} = \text{CFIFO}_x\text{_BASE_ADDRESS} + [(\text{TNXTPTR}_x + \text{CFCTR}_x) \bmod \text{CFIFO_DEPTH}] * 4$$

where

- $a \bmod b$ returns the remainder of the division of a by b .
- CFIFO_x_BASE_ADDRESS is the smallest memory mapped address allocated to a CFIFO_x entry.
- CFIFO_DEPTH is the number of entries contained in a CFIFO - four in this implementation.

When CFS_x in EQADC_CFSR is TRIGGERED, the EQADC generates the proper control signals for the transfer of the entry pointed by Transfer Next Data Pointer. CFUF_x in EQADC_FISR is set when a CFIFO_x underflow event occurs. A CFIFO underflow occurs when the CFIFO is in TRIGGERED state and it becomes empty. No commands will be transferred from an underflowing CFIFO, nor will command transfers from lower priority CFIFOs be blocked. CFIFO_x is empty when the Transfer Next Data Pointer x equals the Push Next Data Pointer x and CFCTR_x is zero. CFIFO_x is full when the Transfer Next Data Pointer x equals the Push Next Data Pointer x and CFCTR_x is not zero.

When the EQADC completes the transfer of an entry from CFIFO_x: the transferred entry is popped from CFIFO_x, the CFIFO counter CFCTR in the EQADC_FISR is decremented by one, and Transfer Next Data Pointer x is incremented by one (or wrapped around) to point to the next entry in the CFIFO. The transfer of entries bound for the on-chip ADCs is considered completed when they are stored in the appropriate CBuffer.

When the EQADC_CFPRx is written and CFIFOx is not full, the CFIFO counter CFCTRx is incremented by one, and the Push Next Data Pointer x then is incremented by one (or wrapped around) to point to the next entry in the CFIFO.

When the EQADC_CFPRx is written but CFIFOx is full, the EQADC will not increment the counter value and will not overwrite any entry in CFIFOx.

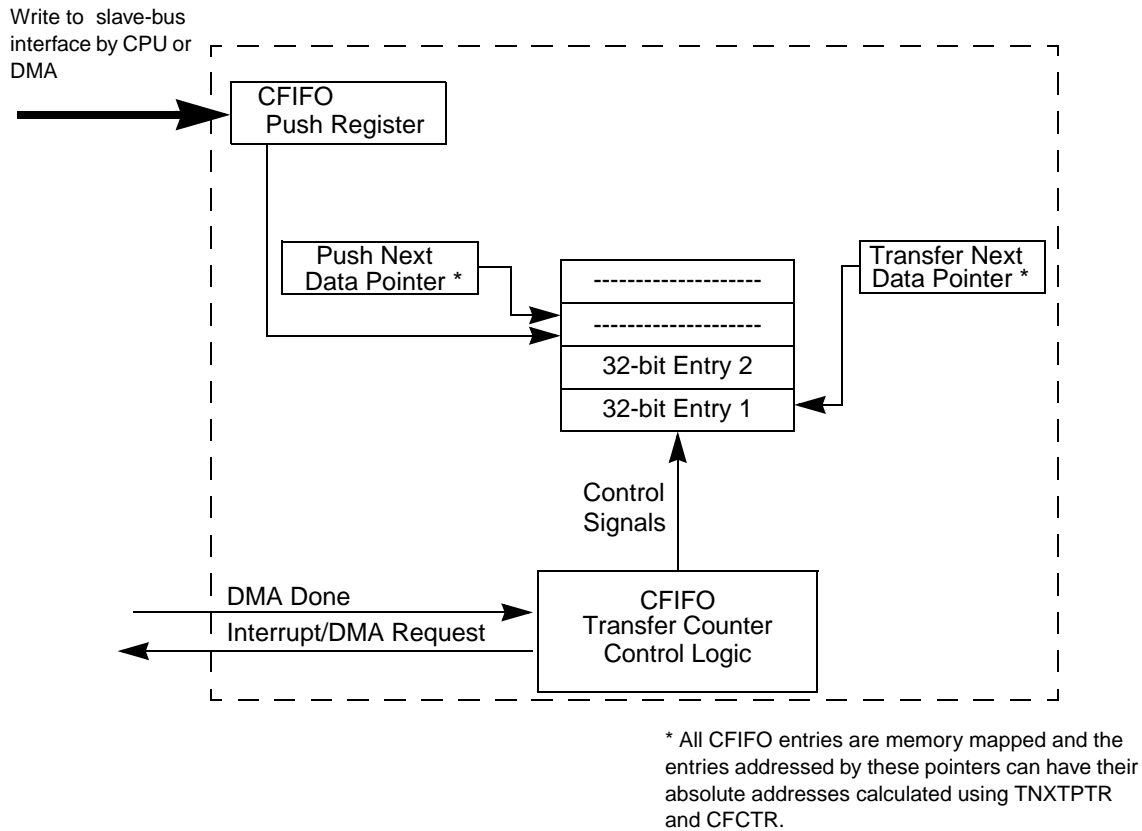
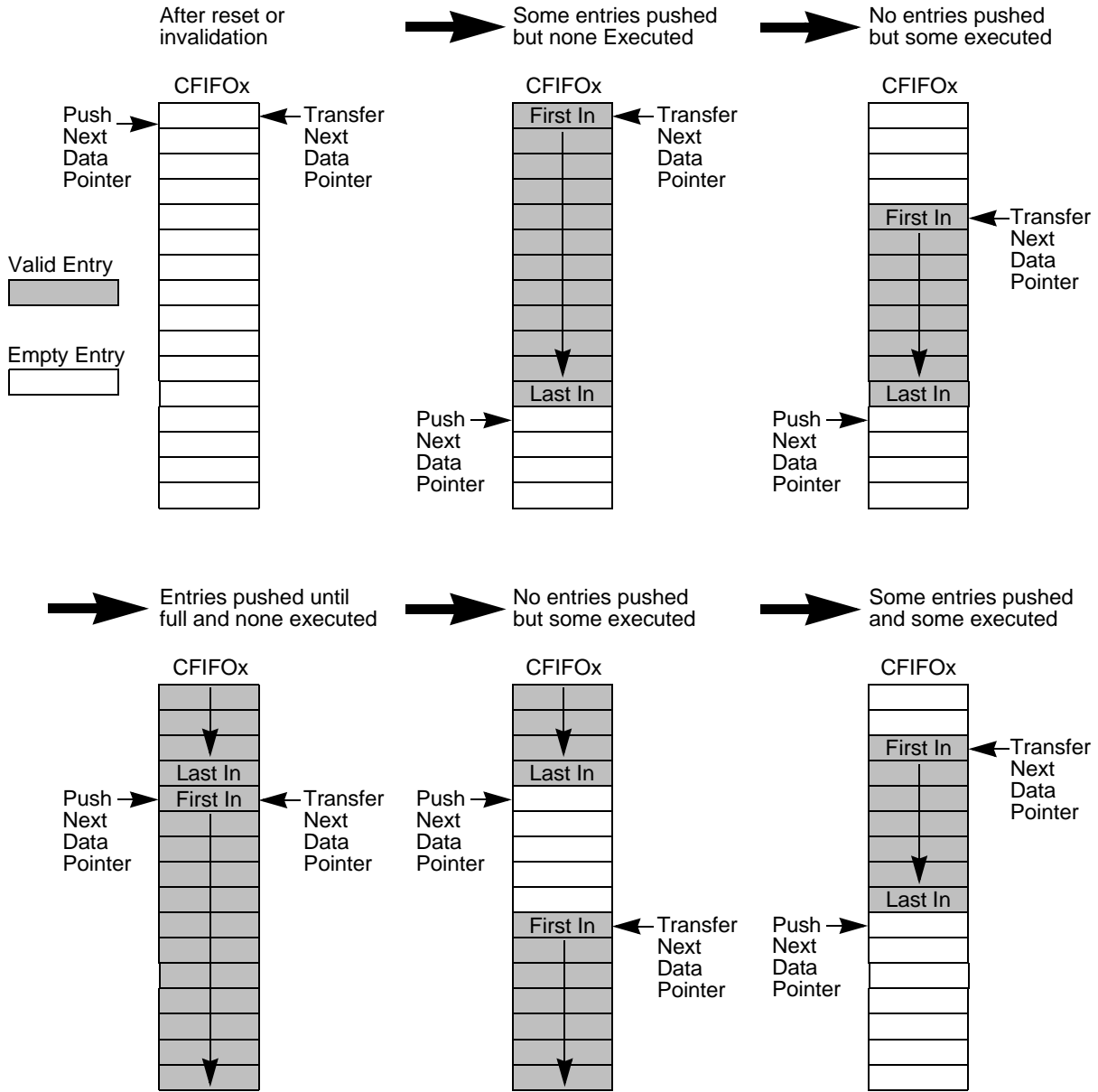

Figure 27-49. CFIFO Diagram

The detailed behavior of the Push Next Data Pointer and Transfer Next Data Pointer is described in the example shown in [Figure 27-50](#) where a CFIFO with 16 entries is shown for clarity of explanation, the actual hardware implementation has only four entries. In this example, CFIFOx with 16 entries is shown in sequence after pushing and transferring entries.



NOTE: x=0, 1, 2, 3, 4, 5

Figure 27-50. CFIFO Entry Pointer Example

27.7.4.2 CFIFO0 Streaming Mode Description

CFIFO0 can be configured to operate in streaming mode to allow repetition of a group of commands several times without the need of refilling the registers as in the normal mode of operation of CFIFOs. This mode makes use of the additional bit in the Conversion Command Word (CCW) called 'Repeat' (REP bit).

The purpose of this bit is to mark in the command queue, where to start a repeating sequence. This location is stored in an additional pointer 'Repeat Pointer'.

Streaming mode requires 2 trigger inputs. The standard queue 0 trigger, in this mode referred to as Repeat Trigger and a new internal trigger input to the eQADC called Advance Trigger (no filter available).

CFIFO0 is configured to operate in streaming mode by setting the bit STRME0 as described in [Section 27.6.2.5, EQADC CFIFO Control Registers \(EQADC_CFCR\)](#). CFIFO0 is eight entries deep in extended mode by setting the bit CFEEE0 in the same EQADC_CFCR register, and each entry is 32 bits long. This CFIFO0 serves as a local storage of a few commands that need to be executed sequentially as in a FIFO but can contain sub-queues that need to be executed several times. The CFFF0 bit in [Section 27.6.2.7, EQADC FIFO and Interrupt Status Registers \(EQADC_FISR\)](#), is used to assure the CFIFO0 is not full and command messages are stored from address 0x0 to 0x7.

27.7.4.2.1 CFIFO0 Operation in Streaming Mode

In Streaming mode, the CFIFO0 is filled with CCWs using the DMA exactly the same as existing modes. The CFIFO executes commands as per the existing modes until it executes a Conversion Command Word with the Repeat bit set. When this CCW is executed, the Repeat Pointer is set to point to this FIFO location and from this CCW onwards, CFIFO0 entries is not invalidated, that is, the Repeat Pointer prevents this and subsequent entries from being overwritten.

The queue continues to execute until a CCW with an asserted Pause bit is completed; then the queue stops and enters the Pause state, waiting for a trigger. This is the same as normal behavior.

The Pause state is exited in one of two ways: Repeat Trigger or Repeat Trigger with Advance Trigger. The Repeat trigger with no Advance trigger causes the Transfer Next Data Pointer to be loaded with the Repeat Pointer location and CCWs are then executed from the Repeat Pointer back to the Pause bit. This means that a section of the CFIFO0 is repeatedly executed every time a Repeat Trigger occurs.

The Repeat trigger with the Advance trigger pending causes all CCWs from the Repeat pointer to the Pause bit to be invalidated and the CCW after the pause bit to be executed. This is achieved by invalidating the Repeat Pointer. The effect is that the queue advances beyond the repeating section of the CFIFO0 to execute new CCWs.

Note that the Advance trigger can occur at any time between Repeat triggers, but is only actioned when the next Repeat trigger occurs. Prior to that it is pending.

In a typical application, the queue is made of some configuration commands to the ADC (to flush the decimator or turn on pad pull-up/down) followed by a repeating section of ADC conversions on one or more ADC channels from one or more sensors; followed by a few more configuration commands; then more repeating ADC conversions, until the entire engine cycle is complete; when the queue is restarted. The mechanism described permits any number of repeating sub-queues to be loaded and executed, interspersed by configuration commands.

27.7.4.2.2 Triggering Description in Streaming Mode

The additional advance-trigger signal ATRIG0 is detected by a separate circuit that is configured by the bit field AMODE0 as described in [Section 27.6.2.5, EQADC CFIFO Control Registers \(EQADC_CFCR\)](#). This trigger signal is used as an advance control of pop pointer of CFIFO0. In addition, it is used as the

enable trigger for the Repeat trigger. This means it is necessary to have an Advance trigger first to enable the detection of the Repeat trigger. When the Repeat trigger is enabled, the Advance trigger is used to advance the pop pointer beyond some loop sub-queue. And it is to disable the Repeat trigger by executing a Pause without a previous REP bit.

A typical sequence of events is presented below to describe the relationship between the triggers.

In Streaming mode, the CFIFO0 is filled with CCWs using the DMA as usual. The two triggers are configured to positive edge and single scan mode.

The SSS bit is asserted and the trigger detector of the Repeat trigger is disabled in the start of the queue. It is necessary to receive the first Advance trigger to enable the detector of the other trigger. This enable is useful when the Repeat trigger is received all the time and the trigger signal can be disabled when it is not desired.

The Advance trigger is received and detected and the Repeat trigger detector is enabled. No commands are executed until now.

The Repeat trigger is detected and the commands start to be executed in sequence. If a REP bit is decoded with the PAUSE bit, the loop is configured and the CFIFO0 commands stop to be executed. The next Repeat trigger is waited to start the execution of the loop again, or the Advance trigger can be detected to break the loop and advance the queue in CFIFO0. The Repeat trigger detector remains enabled.

If the Advance trigger is received and the next command in the CFIFO0 does not present the REP bit set, this means the CFIFO0 is not starting a new loop. In this case (outside a loop) if a PAUSE bit is decoded, this means to disable the Repeat trigger detector. This can be useful if the Repeat trigger is not required for some interval of time. The Repeat trigger detector is enabled again when the next Advance trigger event is detected.

27.7.4.2.3 CFIFO0 Diagram Description in Streaming Mode

Figure 27-51 represents the main components of CFIFO0 in streaming mode. However, some signals behave in a different way from the common operation. The Push Next Data Pointer points to the next available CFIFO0 location for storing data written into the EQADC Command FIFO Push Register. The Transfer Next Data Pointer points to the next entry to be transferred to Cbuffer. The Repeat Pointer points to the first entry of the repeating sub-queue. TNXTPTR in [Section 27.6.2.7, EQADC FIFO and Interrupt Status Registers \(EQADC_FISR\)](#), indicates the index of the entry that is currently being addressed by the Transfer Next Data Pointer, and CFCTR, in the same register, provides the number of entries stored in the CFIFO.

When CFS0 in [Section 27.6.2.10, EQADC CFIFO Status Register \(EQADC_CFSR\)](#), is TRIGGERED, the EQADC generates the proper control signals for the transfer of the entry pointed by Transfer Next Data Pointer. CFUF0 in [Section 27.6.2.7, EQADC FIFO and Interrupt Status Registers \(EQADC_FISR\)](#), is set when CFIFO0 underflow event occurs. A CFIFO underflow occurs when the CFIFO is in TRIGGERED state and it is empty. No commands will be transferred from an underflowing CFIFO, nor will command transfers from lower priority CFIFOs be blocked. CFIFO0 is empty when CFCTR0 is zero. CFIFO0 is full when $(CFCTR0 \text{ mod } CFIFO_DEPTH)$ is zero but CFCTR0 is not zero.

When the EQADC completes the transfer of an entry from CFIFO0 in loop condition: the transferred entry is not popped from CFIFO0, the CFIFO counter CFCTR in the [Section 27.6.2.7, EQADC FIFO and](#)

Interrupt Status Registers (EQADC_FISR), is not decremented by one, and Transfer Next Data Pointer 0 is incremented by one (or wrapped around) to point to the next entry in the CFIFO0.

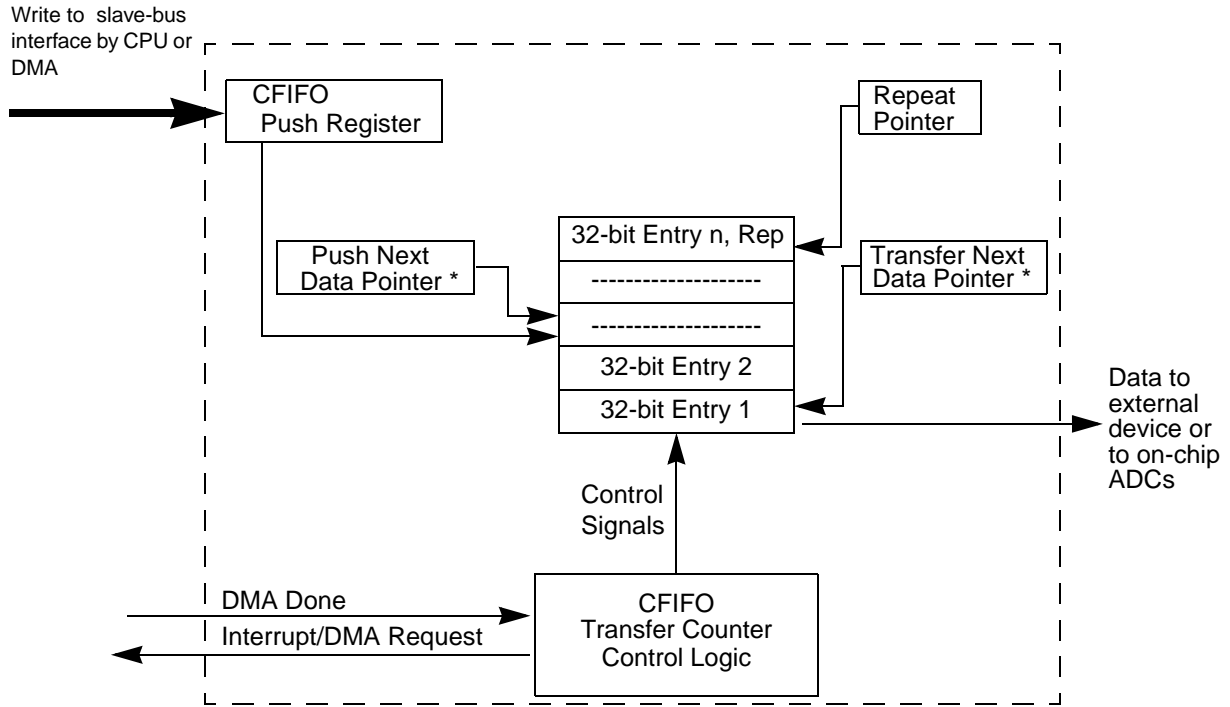

* All CFIFO entries are memory mapped and the entries addressed by these pointers can have their absolute addresses calculated using TNXTPTR and CFCTR.

Figure 27-51. CFIFO0 in Streaming Mode Diagram

The detailed behavior of the Push Next Data Pointer and Transfer Next Data Pointer is described in the example shown in Figure 27-52 where a CFIFO with 16 entries is shown for clarity of explanation, the actual hardware implementation has only four/eight entries. In this example, CFIFO0 with 16 entries is shown in sequence after pushing and transferring entries.

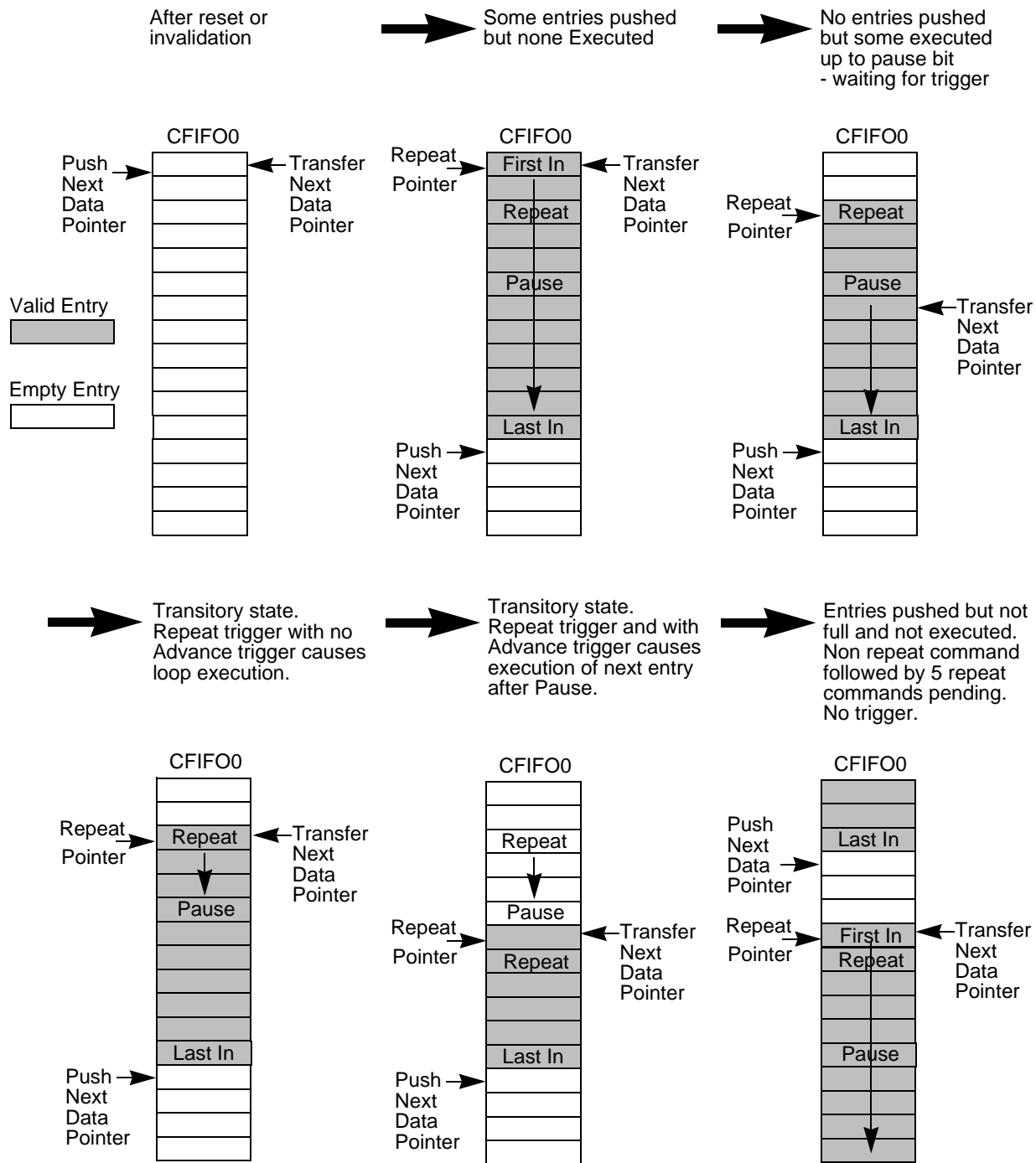

Figure 27-52. CFIFO0 in Streaming Mode Entry Pointer Example

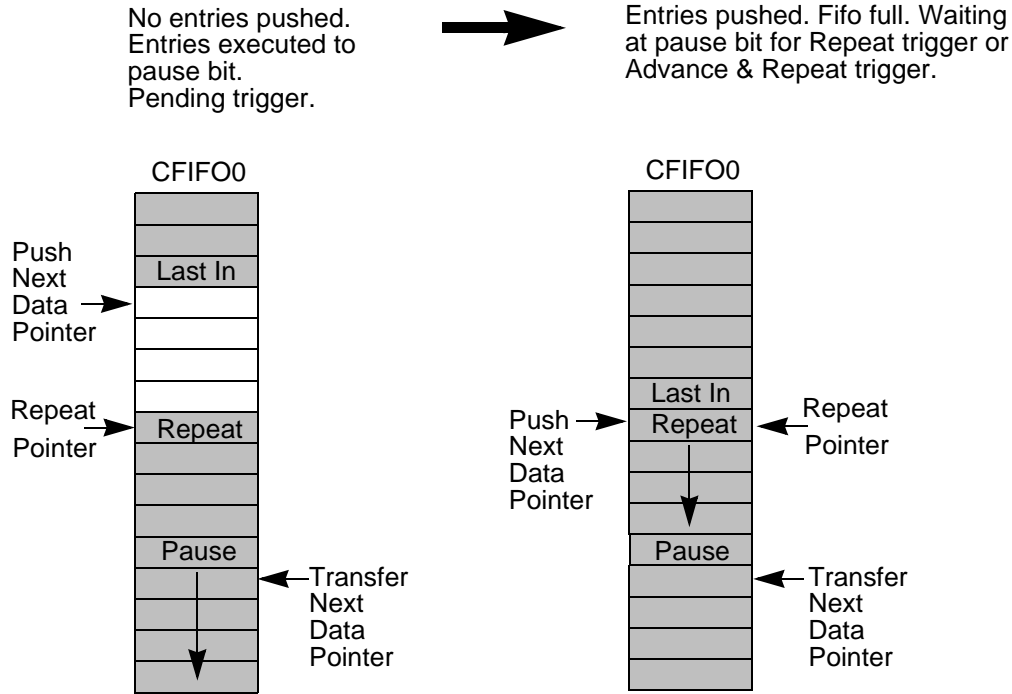

Figure 27-53. CFIFO0 in Streaming Mode Entry Pointer Example (Cont.)

27.7.4.2.4 Streaming Mode Error Conditions

In the repeat state, the existing error conditions still apply, but now there are new ways to trigger them. Now, the CCWs are not being invalidated so the DMA is not able to load more CCWs into those locations. So a queue overflow becomes more likely, and occurs if the repeat loop is longer than 8 entries. If all CCWs in the CFIFO0 are executed and no Pause bit or EOQ bit is detected, the eQADC will signal an underflow error. In practice this may limit a repeating queue to 7 entries since otherwise an underflow will occur at the point a Repeat with Advance trigger occurs, and there is no command in the CFIFO0 to execute. The exception is a final command with both a Pause and an EOQ bit set. The End of Queue bit EOQ continues to operate as in normal mode, unless the Repeat mode is enabled. In this case the Pause bit takes precedence and a Repeat trigger causes the jump back described. A Repeat trigger with Advance trigger causes the queue to end.

Another error condition occur when the repeat trigger is in the TRIGGERED state and a new repeat trigger is received. In this case, a trigger overflow occurs but the CFIFO0 is defined to not restart the loop. The trigger in this case is not used in the CFIFO0, but the overflow is indicated.

27.7.4.3 CFIFO Common Prioritization and Command Transfer

The CFIFO priority is fixed according to the CFIFO number. A CFIFO with a smaller number has a higher priority. When commands of distinct CFIFOs are bound for the same destination (CBuffer), the higher

priority CFIFO is always served first. A TRIGGERED, not-underflowing CFIFO will start the transfer of its commands when:

- its commands are bound for an internal CBuffer that is not full, and it is the highest priority triggered CFIFO sending commands to that CBuffer.

A triggered CFIFO with commands bound for a certain CBuffer consecutively transfers its commands to it until:

- an asserted End Of Queue bit is reached, or;
- an asserted Pause bit is encountered and the CFIFO is configured for edge trigger mode, or;
- CFIFO is configured for level trigger mode and a closed gate is detected, or;
- in case its commands are bound for an internal CBuffer, a higher priority CFIFO that uses the same internal CBuffer is triggered, or;

The prioritization logic of the EQADC, depicted in [Figure 27-54](#), is composed of two independent sub-blocks: one prioritizing CFIFOs with commands bound for CBuffer0 and another prioritizing CFIFOs with commands for CBuffer1. As these sub-blocks are independent, simultaneous writes to CBuffer0 and CBuffer1. The hardware identifies the destination of a command by decoding the BN bit in the command message - see [Section 27.7.2.2, Message Format in EQADC](#), for details.

NOTE

Triggered but empty CFIFOs, underflowing CFIFOs, are not considered for prioritization. No data from these CFIFOs will be sent to the CBuffers and nor will they stop lower priority CFIFOs from transferring commands.

Whenever CBuffer0 is able to receive new entries, the prioritization sub-block selects the highest-priority triggered CFIFO with a command bound for CBuffer0, and writes its command into the buffer. In case CBuffer0 is able to receive new entries but there are no triggered CFIFOs with commands bound for it, nothing is written to the buffer. The sub-block prioritizing CBuffer1 usage behaves in the same way.

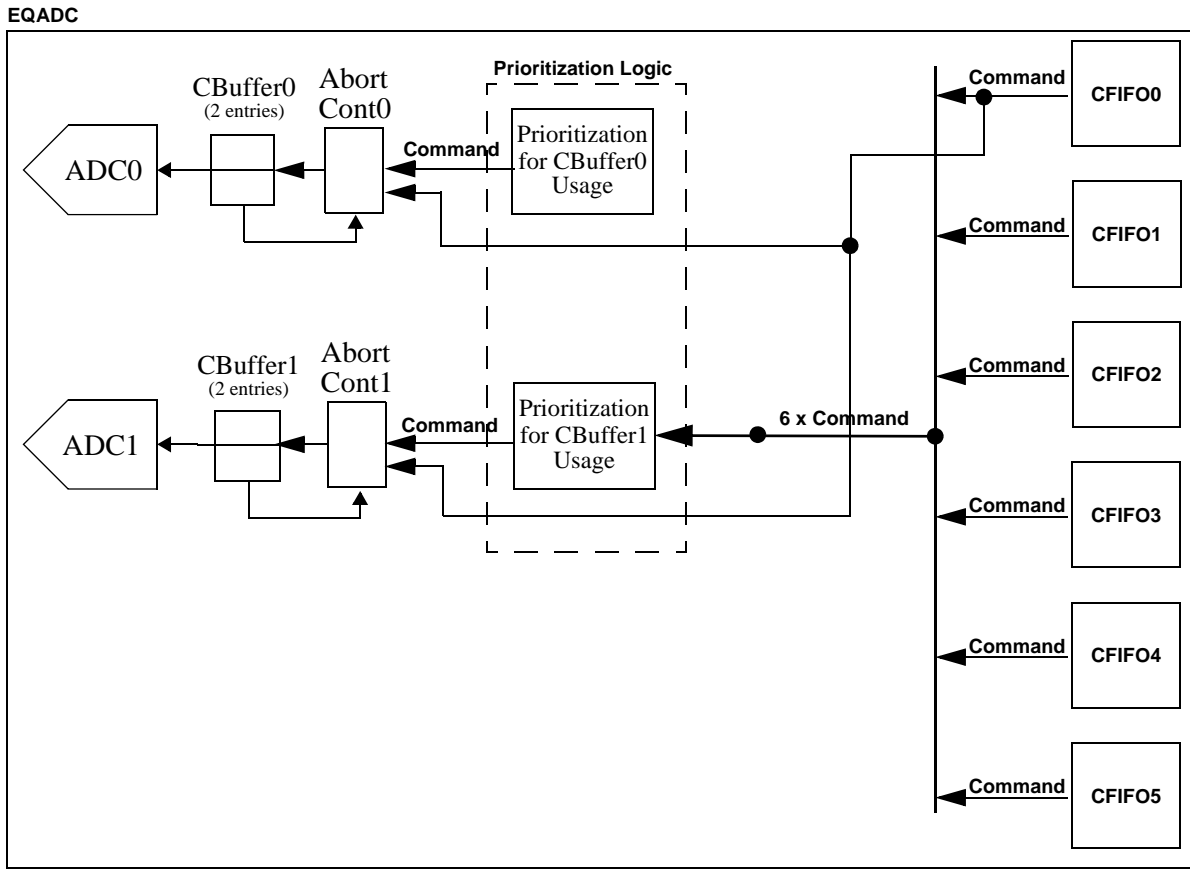

Figure 27-54. CFIFO Prioritization Logic

27.7.4.4 CFIFO Prioritization in Abort Mode

The CFIFO priority does not change when the EQADC is configured to allow abortion of conversion execution in on-chip ADC analog blocks. However, CFIFO0 is the only one that can be enabled to abort conversions.

This feature is necessary when the timing of some conversion is very important. In normal priority scheme, when CFIFO0 is triggered, its conversion command can be put behind 2 pending conversion commands in the Cbuffer due to the queue structure. Considering that these 2 pending commands are from lower priority CFIFOs and that the delay between the trigger and the sampling of the command from Cqueue0 can be unacceptable, EQADC can be configured to permit immediate conversion commands from CFIFO0 with abort function.

When CFIFO0 is triggered and abort is enabled, up to 2 commands in Cbuffer0 or Cbuffer1 are stored in a side register. The abort request signal is generated to ADC0 or ADC1 and the confirmation of ADC reset/ready is waited to send the command from CFIFO0 to the decoded Cbuffer.

After the transfer of all commands from CFIFO0, the recovery phase restores the up to 2 commands that were in Cbuffer when the abort occurred. After this recovery phase, it is established the normal process of prioritization of commands from CFIFOs.

27.7.4.5 Hardware Trigger Event Detection

On this device, the on-chip triggers bypass the filter and the off-chip ETRIG triggers are always filtered and subject to the minimum filter length of 2 clocks. When the filter is bypassed, the ETRIG input signal is not filtered and the logic after the filter receives a copy of this input trigger signal.

The Digital Filter Length field in [Section 27.6.2.2, EQADC External Trigger Digital Filter Register \(EQADC_ETDFR\)](#), specifies the minimum number of platform clocks that the ETRIG0-5 signals must be held at a logic level to be recognized as valid. All ETRIG signals are filtered. A counter for each queue trigger is implemented to detect a transition between logic levels. The counter counts at the platform clock rate. The corresponding counter is cleared and restarted each time the signal transitions between logic levels. When the corresponding counter matches the value specified by the Digital Filter Length field in [Section 27.6.2.2, EQADC External Trigger Digital Filter Register \(EQADC_ETDFR\)](#), the EQADC considers the ETRIG logic level to be valid and passes that new logic level to the rest of the EQADC.

The filter is only for filtering the ETRIG signal. Logic after the filter checks for transitions between filtered values, such as for detecting the transition from a filtered logic level zero to a filter logic level one in rising edge external trigger mode. The EQADC can detect rising edge, falling edge, or level gated external triggers. The digital filter will always be active independently of the status of the MODEx field in [Section 27.6.2.5, EQADC CFIFO Control Registers \(EQADC_CFCR\)](#), but the edge, level detection logic is only active when MODEx is set to a value different from disabled, and in case MODEx is set to single scan mode, when the SSS bit is asserted. Note that the time necessary for an external trigger event to result into a CFIFO status change is not solely determined by the DFL field in the [Section 27.6.2.2, EQADC External Trigger Digital Filter Register \(EQADC_ETDFR\)](#). After being synchronized to the platform clock and filtered, a trigger event is checked against the CFIFO trigger mode. Only then, after a valid trigger event is detected, the EQADC accordingly changes the CFIFO status. Refer to [Figure 27-55](#) for an example.

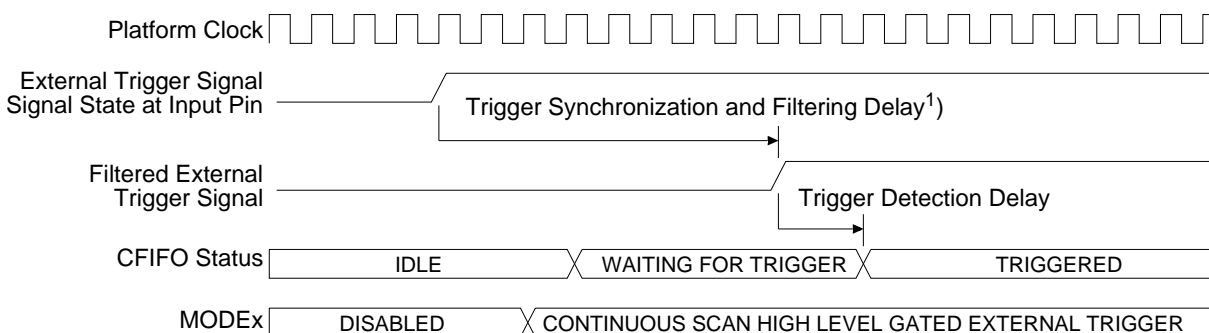

Notes:

1. This delay is about 2 clocks when the filter bypass control is asserted.

Figure 27-55. ETRIG Event Propagation Example

27.7.4.6 CFIFO Scan Trigger Modes

The EQADC supports two different scan modes, single-scan and continuous-scan. Refer to [Table 27-38](#) for a summary of these two scan modes. When a CFIFO is triggered, the EQADC scan mode determines whether the EQADC will stop command transfers from a CFIFO, and wait for software intervention to

rearm the CFIFO to detect new trigger events, upon detection of an asserted EOQ bit in the last transfer. Refer to [Section 27.7.2.2, Message Format in EQADC](#), for details about command formats.

CFIFOs can be configured in single-scan or continuous-scan mode. When a CFIFO is configured in single-scan mode, the EQADC scans the CQueue one time. The EQADC stops future command transfers from the triggered CFIFO after detecting the EOQ bit set in the last transfer. After a EOQ bit is detected, software involvement is required to rearm the CFIFO so that it can detect new trigger events.

When a CFIFO is configured for continuous-scan mode, no software involvement is necessary to rearm the CFIFO to detect new trigger events after an asserted EOQ is detected. In continuous-scan mode the whole CQueue is scanned multiple times.

The EQADC also supports different triggering mechanisms for each scan mode. The EQADC will not transfer commands from a CFIFO until the CFIFO is triggered. The combination of scan modes and triggering mechanisms allows the support of different requirements for scanning input channels. The scan mode and trigger mechanism are configured by programming the MODEx field in [Section 27.6.2.5, EQADC CFIFO Control Registers \(EQADC_CFCR\)](#).

Enabled CFIFOs can be triggered by software or external trigger events. The elapsed time from detecting a trigger to transferring a command is a function of clock frequency, trigger synchronization, trigger filtering or not, programmable trigger events, command transfer, CFIFO prioritization, CBuffer availability, etc. Fast and predictable transfers can be achieved by ensuring that the CFIFO is not underflowing and that the target CBuffer is not full when the CFIFO is triggered.

27.7.4.6.1 Disabled Mode

The MODEx field in [Section 27.6.2.5, EQADC CFIFO Control Registers \(EQADC_CFCR\)](#), for all of the CFIFOs can be changed from any other mode to disabled at any time. No trigger event can initiate command transfers from an CFIFO which has its MODE field programmed to disabled.

NOTE

If MODEx is not disabled, it must not be changed to any other mode besides disabled. If MODEx is disabled and the CFIFO status is IDLE, MODEx can be changed to any other mode.

If MODEx is changed to disabled:

- The CFIFO execution status will change to IDLE. The timing of this change depends on whether a command is being transferred or not:
 - When no command transfer is in progress, the EQADC switches the CFIFO to IDLE status immediately.
 - When a command transfer to an on-chip CBuffer is in progress, the EQADC will complete the transfer, update TC_CF, and switch CFIFO status to IDLE. Command transfers to the internal CBuffers are considered completed when a command is written to the buffers.
- The CFIFOs are not invalidated automatically. The CFIFO still can be invalidated by writing a “1” to the CFINVx bit in [Section 27.6.2.5, EQADC CFIFO Control Registers \(EQADC_CFCR\)](#). Certify that CFS has changed to IDLE before setting CFINVx.
- The TC_CFx value also is not reset automatically, but it can be reset by writing “0” to it.

- The SSS bit in [Section 27.6.2.7, EQADC FIFO and Interrupt Status Registers \(EQADC_FISR\)](#), is negated. The SSS bit can be set even if a “1” is written to the SSE bit in [Section 27.6.2.5, EQADC CFIFO Control Registers \(EQADC_CFCR\)](#), in the same write that the MODEx field is changed to a value other than disabled.
- The trigger detection hardware is reset. If MODEx is changed from disabled to an edge trigger mode, a new edge, matching that edge trigger mode, is needed to trigger the command transfers from the CFIFO.

NOTE

CFIFO fill requests, which generated when CFFF is asserted, are not automatically halted when MODEx is changed to disabled. CFIFO fill requests will still be generated until CFFE is cleared in [Section 27.6.2.6, EQADC Interrupt and DMA Control Registers \(EQADC_IDCR\)](#).

27.7.4.6.2 Single-Scan Mode

In single-scan mode, a single pass through a sequence of command messages in a CQueue is performed.

In single-scan software trigger mode, the CFIFO is triggered by an asserted Single-Scan Status bit (SSS) in [Section 27.6.2.7, EQADC FIFO and Interrupt Status Registers \(EQADC_FISR\)](#). The SSS bit is set by writing “1” to the Single-Scan Enable bit (SSE) in [Section 27.6.2.5, EQADC CFIFO Control Registers \(EQADC_CFCR\)](#).

In single-scan edge- or level-trigger mode, the respective triggers are only detected when the SSS bit is asserted. When the SSS bit is negated, all trigger events for that CFIFO are ignored. Writing a “1” to the SSE bit can be done during the same write cycle that the CFIFO operation mode is configured.

Only the EQADC can clear the SSS bit. Once SSS is asserted, it remains asserted until the EQADC completes the CQueue scan, or the CFIFO operation mode (MODEx) in [Section 27.6.2.5, EQADC CFIFO Control Registers \(EQADC_CFCR\)](#), is changed to disabled. The SSSx bit will be negated while MODEx is disabled.

Single-Scan Software Trigger

When single-scan software trigger mode is selected, the CFIFO is triggered by an asserted SSS bit. The SSS bit is asserted by writing “1” to the SSE bit. Writing to SSE while SSS is already asserted will not have any effect on the state of the SSS bit, nor will it cause a trigger overrun event.

The CFIFO commands start to be transferred when the CFIFO becomes the highest priority CFIFO using a not-full on-chip CBuffer. When an asserted EOQ bit is encountered, the EQADC will clear the SSS bit. Setting the SSS bit is required for the EQADC to start the next scan of the queue.

The Pause bit has no effect in single-scan software trigger mode.

Single-Scan Edge Trigger

When SSS is asserted and an edge triggered mode is selected for a CFIFO, an appropriate edge on the associated trigger signal causes the CFIFO to become TRIGGERED. For example, if rising-edge trigger mode is selected, the CFIFO becomes TRIGGERED when a rising edge is sensed on the trigger signal.

The CFIFO commands start to be transferred when the CFIFO becomes the highest priority CFIFO using a not-full on-chip CBuffer or an not-full external CBuffer.

When an asserted EOQ bit is encountered, the EQADC clears SSS and stops command transfers from the CFIFO. An asserted SSS bit and a subsequent edge trigger event are required to start the next scan for the CFIFO. When an asserted Pause bit is encountered, the EQADC stops command transfers from the CFIFO, but SSS remains set. Another edge trigger event is required for command transfers to continue. A trigger overrun happens when the CFIFO is in TRIGGERED state and an edge trigger event is detected.

Single-Scan Level Trigger

When SSS is asserted and a level gated trigger mode is selected, the input level on the associated trigger signal puts the CFIFO in TRIGGERED state. When the CFIFO is asserted to high-level gated trigger, a high level signal opens the gate, and a low level closes the gate. When the CFIFO is set to low-level gated trigger mode, a low level signal opens the gate, and a high level closes the gate. If the corresponding level is already present, setting the SSS bit triggers the CFIFO. The CFIFO commands start to be transferred when the CFIFO becomes the highest priority CFIFO using a not-full on-chip CBuffer or a not -full external CBuffer.

The EQADC clears the SSS bit and stops transferring commands from a TRIGGERED CFIFO when an asserted EOQ bit is encountered or when CFIFO status changes from TRIGGERED due to the detection of a closed gate. Command transfers will restart from the point they have stopped.

The Pause bit has no effect in single-scan level-trigger mode.

27.7.4.6.3 Continuous-Scan Mode

In continuous-scan mode, multiple passes looping through a sequence of command messages in a CQueue are executed. When a CFIFO is programmed for a continuous-scan mode, the SSE bit in the [Section 27.6.2.5, EQADC CFIFO Control Registers \(EQADC_CFCR\)](#), does not have any effect.

Continuous-Scan Software Trigger

When a CFIFO is programmed to continuous-scan software trigger mode, the CFIFO is triggered immediately. The CFIFO commands start to be transferred when the CFIFO becomes the highest priority CFIFO using a not-full on-chip CBuffer. When a CFIFO is programmed to run in continuous-scan software trigger mode, the EQADC will not halt transfers from the CFIFO until the CFIFO operation mode is modified to disabled or a higher priority CFIFO preempts it. Although command transfers will not stop upon detection of an asserted EOQ bit, the EOQF is set and, if enabled, an EOQ interrupt request is generated.

The Pause bit has no effect in continuous-scan software trigger mode.

Continuous-Scan Edge Trigger

When rising, falling, or either edge trigger mode is selected for a CFIFO, a corresponding edge on the associated ETRIG signal places the CFIFO in TRIGGERED state. The CFIFO commands start to be transferred when the CFIFO becomes the highest priority CFIFO using a not-full on-chip CBuffer.

When an EOQ or a Pause is encountered, the EQADC halts command transfers from the CFIFO and, if enabled, the appropriate interrupt requests are generated. Another edge trigger event is required to resume command transfers but no software involvement is required to rearm the CFIFO in order to detect such event.

A trigger overrun happens when the CFIFO is already in TRIGGERED state and a new edge trigger event is detected.

Continuous-Scan Level Trigger

When high or low level gated trigger mode is selected, the input level on the associated trigger signal places the CFIFO in TRIGGERED state. When high-level gated trigger is selected, a high-level signal opens the gate, and a low level closes the gate. The CFIFO commands start to be transferred when the CFIFO becomes the highest priority CFIFO using a not-full on-chip CBuffer. Although command transfers will not stop upon detection of an asserted EOQ bit at the end of a command transfer, the EOQF is asserted and, if enabled, an EOQ interrupt request is generated.

The EQADC stops transferring commands from a TRIGGERED CFIFO when CFIFO status changes from TRIGGERED due to the detection of a closed gate. If a closed gate is detected while no command transfers are taking place and the CFIFO status is TRIGGERED, the CFIFO status is immediately changed to WAITING FOR TRIGGER and the PF flag is asserted. Command transfers will restart as the gate opens.

The Pause bit has no effect in continuous-scan level-trigger mode.

27.7.4.6.4 CFIFO Scan Trigger Mode Start/Stop Summary

Table 27-38 summarizes the start and stop conditions of command transfers from CFIFOs for all of the single-scan and continuous-scan trigger modes.

Table 27-38. CFIFO Scan Trigger Mode - Command Transfer Start/Stop Summary

| Trigger Mode | Requires Asserted SSS to Recognize Trigger Events? | Command Transfer Start/Restart Condition | Stop on asserted EOQ bit ¹ ? | Stop on asserted Pause bit ² ? | Other Command Transfer Stop Condition ^{3 4} |
|--------------------------|--|---|---|---|--|
| Single Scan Software | Don't Care | Asserted SSS bit. | Yes | No | None. |
| Single Scan Edge | Yes | A corresponding edge occurs. | Yes | Yes | None. |
| Single Scan Level | Yes | Gate is opened. | Yes | No | EQADC also stops transfers from the CFIFO when CFIFO status changes from TRIGGERED due to the detection of a closed gate. ⁵ |
| Continuous Scan Software | No | CFIFO starts automatically after being configured into this mode. | No | No | None. |
| Continuous Scan Edge | No | A corresponding edge occurs. | Yes | Yes | None. |

Table 27-38. CFIFO Scan Trigger Mode - Command Transfer Start/Stop Summary (continued)

| Trigger Mode | Requires Asserted SSS to Recognize Trigger Events? | Command Transfer Start/Restart Condition | Stop on asserted EOQ bit ¹ ? | Stop on asserted Pause bit ² ? | Other Command Transfer Stop Condition ^{3 4} |
|-----------------------|--|--|---|---|--|
| Continuous Scan Level | No | Gate is opened. | No | No | EQADC also stops transfers from the CFIFO when CFIFO status changes from TRIGGERED due to the detection of a closed gate. ⁵ |

NOTES:

- 1 Refer to [Section 27.7.4.7.2, CQueue Completion Status](#), for more information on EOQ.
- 2 Refer to [Section 27.7.4.7.3, Pause Status](#), for more information on Pause.
- 3 EQADC always stops command transfers from a CFIFO when the CFIFO operation mode is disabled.
- 4 EQADC always stops command transfers from a CFIFO when a higher priority CFIFO is triggered. Refer to [Section 27.7.4.3, CFIFO Common Prioritization and Command Transfer](#), for information on CFIFO priority.
- 5 If a closed gate is detected while no command transfers are taking place, it will have immediate effect on the CFIFO status. If a closed gate is detected during the serial transmission of a command to the external device, it will have no effect on the CFIFO status until the transmission completes.

27.7.4.7 CFIFO and Trigger Status

27.7.4.7.1 CFIFO Operation Status

Each CFIFO has its own CFIFO status field. CFIFO status (CFS) can be read from [Section 27.6.2.10, EQADC CFIFO Status Register \(EQADC_CFSR\)](#). [Figure 27-56](#) and [Table 27-39](#) indicate the CFIFO status switching condition. Refer to [Figure 27-17](#) for the meaning of each CFIFO operation status. The last CFIFO to transfer a command to an on-chip CBuffer can be read from the LCFTCB n ($n=0,1$) fields in the [Section 27.6.2.9, EQADC CFIFO Status Snapshot Registers \(EQADC_CFSSR\)](#). The last CFIFO to transfer a command to a specific external CBuffer can be identified by reading the LCFTSSI and ECBNI fields in the [Section 27.6.2.9, EQADC CFIFO Status Snapshot Registers \(EQADC_CFSSR\)](#).

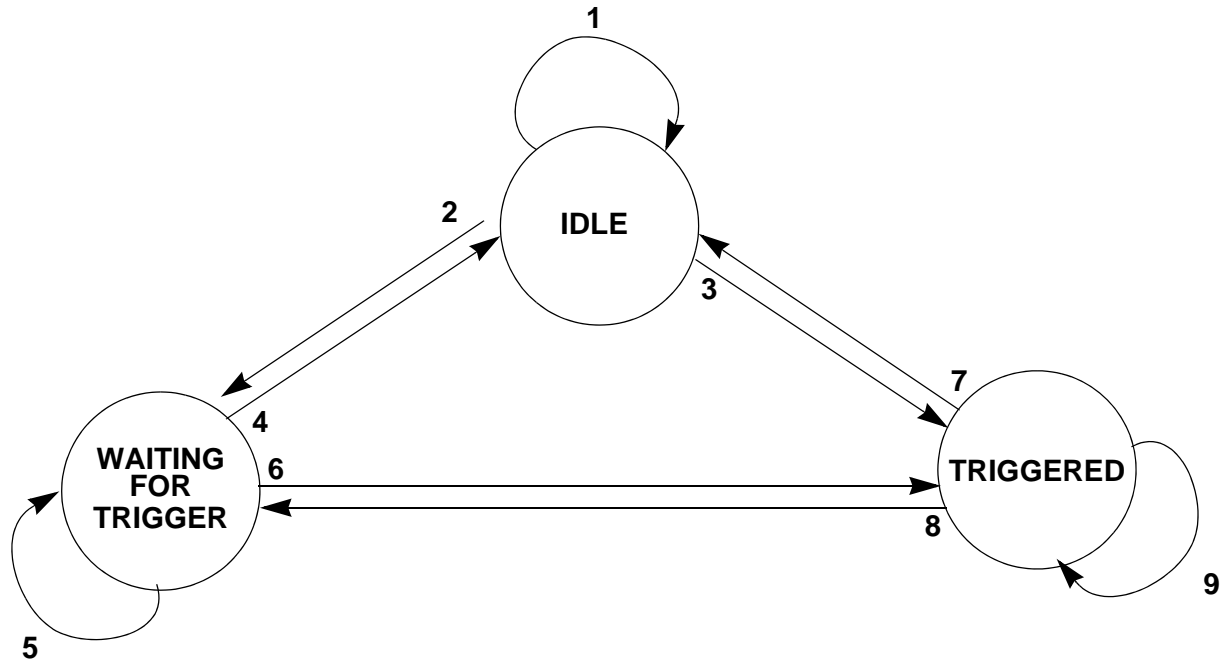

Figure 27-56. State Machine of CFIFO Status

Table 27-39. Command FIFO Status Switching Condition

| No. | From Current CFIFO Status (CFS) | To New CFIFO Status (CFS) | Status Switching Condition |
|-----|---------------------------------|----------------------------|--|
| 1 | IDLE (00) | IDLE (0b00) | — CFIFO Mode is programmed to disabled, OR — CFIFO Mode is programmed to single-scan edge or level trigger mode and SSS is negated. |
| 2 | | WAITING FOR TRIGGER (0b10) | — CFIFO Mode is programmed to continuous-scan edge or level trigger mode, OR — CFIFO Mode is programmed to single-scan edge or level trigger mode and SSS is asserted, OR — CFIFO Mode is programmed to single-scan software trigger mode. |
| 3 | | TRIGGERED (0b11) | — CFIFO Mode is programmed to continuous-scan software trigger mode |
| 4 | WAITING FOR TRIGGER (10) | IDLE (0b00) | — CFIFO Mode is modified to disabled mode. |
| 5 | | WAITING FOR TRIGGER (0b10) | — No trigger occurred. |
| 6 | | TRIGGERED (0b11) | — Appropriate edge or level trigger occurred, OR — CFIFO Mode is programmed to single-scan software trigger mode and SSS bit is asserted. |

Table 27-39. Command FIFO Status Switching Condition (continued)

| No. | From Current CFIFO Status (CFS) | To New CFIFO Status (CFS) | Status Switching Condition |
|-----|---------------------------------|----------------------------|--|
| 7 | TRIGGERED (11) | IDLE (0b00) | — CFIFO in single-scan mode, EQADC detects the EOQ bit asserted at end of command transfer, and CFIFO Mode is not modified to disabled. OR — CFIFO, in single-scan level trigger mode, and the gate closes while no commands are being transferred from the CFIFO, and CFIFO Mode is not modified to disabled. OR — CFIFO, in single-scan level trigger mode, and EQADC detects a closed gated at end of command transfer, and CFIFO Mode is not modified to disabled. OR — CFIFO Mode is modified to disabled mode and CFIFO was not transferring commands. —CFIFO Mode is modified to disabled mode while CFIFO was transferring commands, and CFIFO completes or aborts the transfer. |
| 8 | | WAITING FOR TRIGGER (0b10) | — CFIFO in single or continuous-scan edge trigger mode, EQADC detects the Pause bit asserted at the end of command transfer, the EOQ bit in the same command is negated, and CFIFO Mode is not modified to disabled, OR — CFIFO in continuous-scan edge trigger mode, EQADC detects the EOQ bit asserted at the end of command transfer, and CFIFO Mode is not modified to disabled, OR — CFIFO, in continuous-scan level trigger mode, and the gate closes while no commands are being transferred from the CFIFO, and CFIFO Mode is not modified to disabled, OR — CFIFO, in continuous-scan level trigger mode, and EQADC detects a closed gated at end of command transfer, and CFIFO Mode is not modified to disabled. |
| 9 | | TRIGGERED (0b11) | — No event to switch to IDLE or WAITING FOR TRIGGER status has happened. |

27.7.4.7.2 CQueue Completion Status

The End of Queue Flag (EOQF) in [Section 27.6.2.7, EQADC FIFO and Interrupt Status Registers \(EQADC_FISR\)](#), is asserted when the EQADC completes the transfer of a CQueue entry with an asserted EOQ bit. Software sets the EOQ bit in the last Command Message of a CQueue to indicate that this entry is the end of the CQueue - see [Section 27.7.2.2, Message Format in EQADC](#), for information on command message formats. The transfer of entries bound for the on-chip ADCs is considered completed when they are stored in the appropriate CBuffer.

The command with a EOQ bit asserted is valid and will be transferred. When EOQIE in [Section 27.6.2.5, EQADC CFIFO Control Registers \(EQADC_CFCR\)](#), and EOQF are asserted, the EQADC will generate an End of Queue interrupt request.

In single-scan modes, command transfers from the corresponding CFIFO will cease when EQADC completes the transfer of a entry with an asserted EOQ. Software involvement is required to rearm the CFIFO so that it can detect new trigger events.

NOTE

An asserted EOQF_x only implies that EQADC has finished transferring a command with an asserted EOQ bit from CFIFO_x. It does not imply that result data for the current command and for all previously transferred commands has been returned to the appropriate RFIFO.

27.7.4.7.3 Pause Status

In edge trigger mode, when the EQADC completes the transfer of a CFIFO entry with an asserted Pause bit, the EQADC will stop future command transfers from the CFIFO and set the corresponding Pause Flag (PF) in [Section 27.6.2.7, EQADC FIFO and Interrupt Status Registers \(EQADC_FISR\)](#). Refer to [Section 27.7.2.2, Message Format in EQADC](#), for information on command message formats. The EQADC ignores the Pause bit in command messages in any software and external level trigger mode. The EQADC sets the PF flag upon detection of an asserted Pause bit only in single or continuous-scan edge trigger mode. When the PF flag is set for a CFIFO in single-scan edge trigger mode, the SSS bit will not be cleared in [Section 27.6.2.7, EQADC FIFO and Interrupt Status Registers \(EQADC_FISR\)](#).

In level trigger mode, the definition of the PF flag has been redefined. In level trigger mode, when CFIFO_x is in TRIGGERED status, PF_x is set when CFIFO status changes from TRIGGERED due to detection of a closed gate. The pause flag interrupt routine can be used to verify if the a complete scan of the CQueue was performed. If a closed gate is detected while no command transfers are taking place, it will have immediate effect on the CFIFO status.

When PIE in [Section 27.6.2.5, EQADC CFIFO Control Registers \(EQADC_CFCR\)](#), and PF are asserted, the EQADC will generate a Pause interrupt request.

NOTE

In edge trigger mode, an asserted PF_x only implies that the EQADC finished transferring a command with an asserted PAUSE bit from CFIFO_x. It does not imply that result data for the current command and for all previously transferred commands has been returned to the appropriate RFIFO.

NOTE

In software or level trigger mode, when the EQADC completes the transfer of an entry from CFIFO_x with an asserted Pause bit, PF_x will not be set and command transfers will continues without pausing.

27.7.4.7.4 Trigger Overrun Status

NOTEWhen a CFIFO is configured for edge- or level-trigger mode and is in TRIGGERED state, an additional trigger occurring for the same CFIFO results in a trigger overrun. The trigger overrun bit for the corresponding CFIFO will be set (TORF_x = 1) in [Section 27.6.2.7, EQADC FIFO and Interrupt Status Registers \(EQADC_FISR\)](#). When TORIE in [Section 27.6.2.5, EQADC CFIFO Control Registers \(EQADC_CFCR\)](#), and TORF are asserted, the EQADC generates a trigger overrun interrupt request.

For CFIFOs configured for level-trigger mode, a trigger overrun does not occur.

NOTE

The trigger overrun flag will not set for CFIFOs configured for software trigger mode.

27.7.4.7.5 Command Sequence Non-Coherency Detection

The EQADC provides a mechanism to indicate if a command sequence has been completely executed without interruptions. A command sequence is defined as a group of consecutive commands bound for the same CBuffer and it is expected to be executed without interruptions. A command sequence is coherent if its commands are executed in order without interruptions. Since commands are stored in the CBuffers before being executed in the EQADC, a command sequence is coherent if, while it is transferring commands to a CBuffer, the buffer is only fed with commands from that sequence without ever becoming empty.

A command sequence starts when:

- a CFIFO in TRIGGERED state transfers its first command to CBuffer.
- the CFIFO is constantly transferring commands and the previous command sequence ended.
- the CFIFO resumes command transfers after being interrupted.

And a command sequence ends when:

- an asserted EOQ bit is detected on the last transferred command.
- CFIFO is in edge-trigger mode and asserted PAUSE bit is detected on the last transferred command.
- the CBuffer to which the next command is bound is different from the one to which the last command was transferred.

[Figure 27-57](#) shows examples of how the EQADC would detect command sequences when transferring commands from a CFIFO to a CBuffer. The smallest possible command sequence can have a single command as shown in example 3 of [Figure 27-57](#).

CQueue with a two command sequences

| |
|------------------------|
| CF5_CB1_CM0 |
| CF5_CB1_CM1 |
| CF5_CB1_CM2 |
| CF5_CB1_CM3 (Pause =1) |
| CF5_CB1_CM4 |
| CF5_CB1_CM5 |
| CF5_CB1_CM6 (EOQ =1) |

Example 1

Assuming that these commands are transferred by a CFIFO configured for edge trigger mode and the command transfers are never interrupted, the EQADC would check for non-coherency of two command sequences: one formed by commands 0, 1, 2, 3, and the other by commands 4, 5, 6.

CQueue with a three command sequences

| |
|----------------------|
| CF5_CB1_CM0 |
| CF5_CB1_CM1 |
| CF5_CB1_CM2 |
| CF5_CB0_CM3 |
| CF5_CB0_CM4 |
| CF5_CB1_CM5 |
| CF5_CB1_CM6 (EOQ =1) |

Example 2

Assuming that command transfers from the CFIFO are never interrupted, the EQADC would check for non-coherency of three command sequences. The first being formed by commands 0, 1, 2, the second by commands 3, 4 and the third by commands 5, 6. Note that even when the commands of this CQueue are transferred through a CFIFO in continuous-scan mode, the first three commands and the last two commands of this CQueue would still constitute two distinct command sequences, although they are all bound for the same CBuffer, since an asserted EOQ ends a command sequence.

CQueue with a seven command sequences

| |
|----------------------|
| CF5_CB1_CM0 |
| CF5_CB2_CM1 |
| CF5_CB3_CM2 |
| CF5_CB1_CM3 |
| CF5_CB0_CM4 |
| CF5_CB2_CM5 |
| CF5_CB1_CM6 (EOQ =1) |

Example 3

The EQADC would check for non-coherency of seven command sequences, all containing a single command, but NCF would never get set.

CF_x_CB_a_CM_n - Command *n* in CFIFO_x bound for CBuffer_a

Figure 27-57. Command Sequence Examples

The NCF flag is used to indicate command sequence non-coherency. When the NCF_x flag is asserted, it indicates that the command sequence being transferred through CFIFO_x became non-coherent. The NCF flag only becomes asserted for CFIFOs in TRIGGERED state.

A command sequence is non-coherent when, after transferring the first command of a sequence from a CFIFO to a CBuffer, it cannot successively send all the other commands of the sequence before any of the following conditions are true:

- The CFIFO through which commands are being transferred is preempted by a higher priority CFIFO which sends commands to the same CBuffer. The NCF flag becomes asserted immediately after the first command transfer from the preempting CFIFO, that is the higher priority CFIFO, to the CBuffer in use is completed. See [Figure 27-58](#).

Once command transfers restart/continue, the non-coherency hardware will behave as if the command sequence started from that point. [Figure 27-59](#) depicts how the non-coherency hardware will behave when a non-coherency event is detected.

NOTE

If MODEx is changed to disabled while a CFIFO is transferring commands, the NCF flag for that CFIFO will not become asserted.

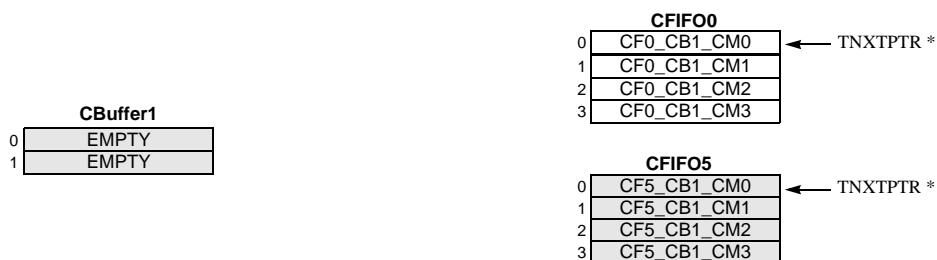

(a) CFIFO0 and CFIFO5 both have commands to be sent to CBuffer1, and both are not triggered

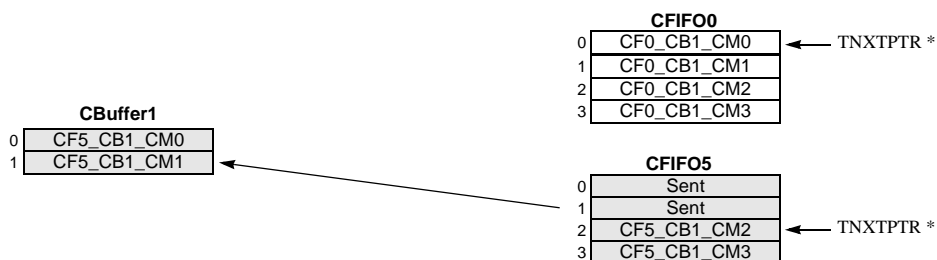

(b) CFIFO5 becomes triggered and transfers two commands to CBuffer1

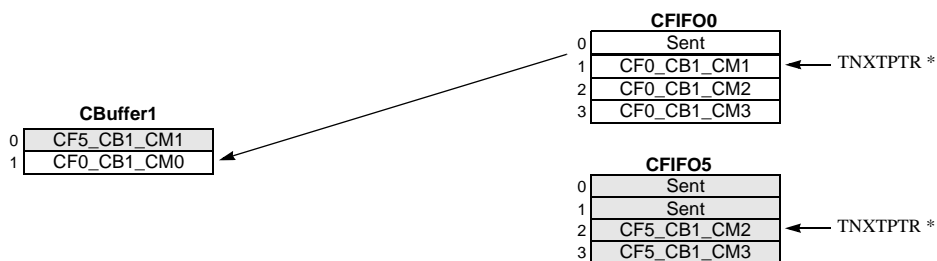

(c) CFIFO0 becomes triggered and transfers a command to CBuffer1. The sequence sent through CFIFO5 becomes non-coherent.

* TNXTPTR - Transfer Next Data Pointer
 CF_x_CB_a_CM_n - Command *n* in CFIFO_x bound for CBuffer_a

Figure 27-58. Non-Coherency Event when Different CFIFOs use the same CBuffer

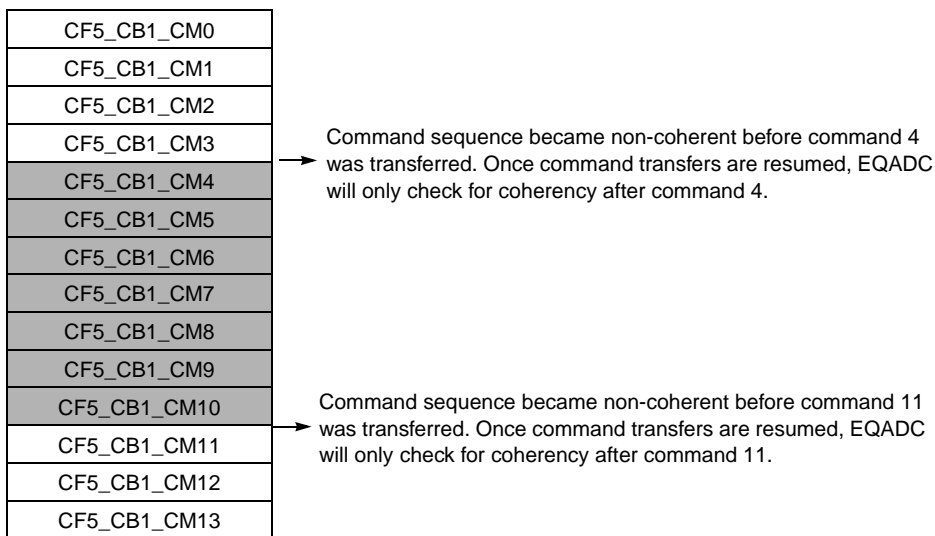

Figure 27-59. Non-coherency Detection when Transfers from a Command Sequence are Interrupted

27.7.5 EQADC Result FIFOs

27.7.5.1 RFIFO Basic Functionality

There are six RFIFOs located in the EQADC. Each RFIFO is four entries deep, and each RFIFO entry is 16 bits long. Each RFIFO serves as a temporary storage location for the one of the RQueues allocated in system memory. Result data is saved in the RFIFOs before being moved into the system RQueues. When an RFIFO is not empty, the EQADC sets the corresponding RFDF bit in [Section 27.6.2.7, EQADC FIFO and Interrupt Status Registers \(EQADC_FISR\)](#). If RFDE is asserted in [Section 27.6.2.6, EQADC Interrupt and DMA Control Registers \(EQADC_IDCR\)](#), the EQADC generates a request so that an RFIFO entry is moved to the RQueue. An interrupt request, served by the host CPU, is generated when RFDS is negated, and a DMA request, served by the DMAC, is generated when RFDS is asserted. The host CPU or the DMAC responds to these requests by reading [Section 27.6.2.4, EQADC Result FIFO Pop Registers \(EQADC_RFPR\)](#), to retrieve data from the RFIFO.

NOTE

The DMAC should be configured to read a single result (16-bit data) from the RFIFO pop registers for every asserted DMA request it acknowledges. Refer to [Section 27.8.2, EQADC/DMAC Interface](#), for DMAC configuration guidelines.

NOTE

Reading a word, a half-word, or any bytes from EQADC_RFPRx will pop an entry from RFIFOx, and the RFCTRx field will be decremented by one.

[Figure 27-60](#) describes the important components in the RFIFO. Each RFIFO is implemented as a circular set of registers to avoid the need to move all entries at each push/pop operation. The Pop Next Data Pointer always points to the next RFIFO message to be retrieved from the RFIFO when reading EQADC_RFPR.

The Receive Next Data Pointer points to the next available RFIFO location for storing the next incoming message from the on-chip ADCs. The *RFIFO Counter Logic* counts the number of entries in RFIFO and generates interrupt or DMA requests to drain the RFIFO.

POPNXTPTR in [Section 27.6.2.7, EQADC FIFO and Interrupt Status Registers \(EQADC_FISR\)](#), indicates which entry is currently being addressed by the Pop Next Data Pointer, and RFCTR, in the same register, provides the number of entries stored in the RFIFO. Using POPNXTPTR and RFCTR, the absolute addresses for Pop Next Data Pointer and Receive Next Data Pointer can be calculated using the following formulas:

$$\text{Pop Next Data Pointer Address} = \text{RFIFO}_x\text{_BASE_ADDRESS} + \text{POPNXTPTR}_x * 4$$

$$\text{Receive Next Data Pointer Address} = \text{RFIFO}_x\text{_BASE_ADDRESS} + [(\text{POPNXTPTR}_x + \text{RFCTR}_x) \bmod \text{RFIFO_DEPTH}] * 4$$

where

- $a \bmod b$ returns the remainder of the division of a by b .
- RFIFO_x_BASE_ADDRESS is the smallest memory mapped address allocated to an RFIFO_x entry.
- RFIFO_DEPTH is the number of entries contained in a RFIFO - four in this implementation.

When a new message arrives and RFIFO_x is not full, the EQADC copies its contents into the entry pointed by the Receive Next Data Pointer. The RFIFO counter RFCTR_x in [Section 27.6.2.7, EQADC FIFO and Interrupt Status Registers \(EQADC_FISR\)](#), is incremented by one, and the Receive Next Data Pointer x is also incremented by one (or wrapped around) to point to the next empty entry in RFIFO_x. However, if the RFIFO_x is full, the EQADC sets the RFOF in [Section 27.6.2.7, EQADC FIFO and Interrupt Status Registers \(EQADC_FISR\)](#). The RFIFO_x will not overwrite the older data in the RFIFO, the new data will be ignored, and the Receive Next Data Pointer x is not incremented or wrapped around. RFIFO_x is full when the Receive Next Data Pointer x equals the Pop Next Data Pointer x and RFCTR_x is not zero. RFIFO_x is empty when the Receive Next Data Pointer x equals the Pop Next Data Pointer x and RFCTR_x is zero.

When the EQADC RFIFO Pop Register x is read and the RFIFO_x is not empty, the RFIFO counter RFCTR_x is decremented by one, and the POP Next Data Pointer is incremented by one (or wrapped around) to point to the next RFIFO entry.

When the EQADC RFIFO Pop Register x is read and RFIFO_x is empty, EQADC will not decrement the counter value and the POP Next Data Pointer x will not be updated. The read value will be undefined.

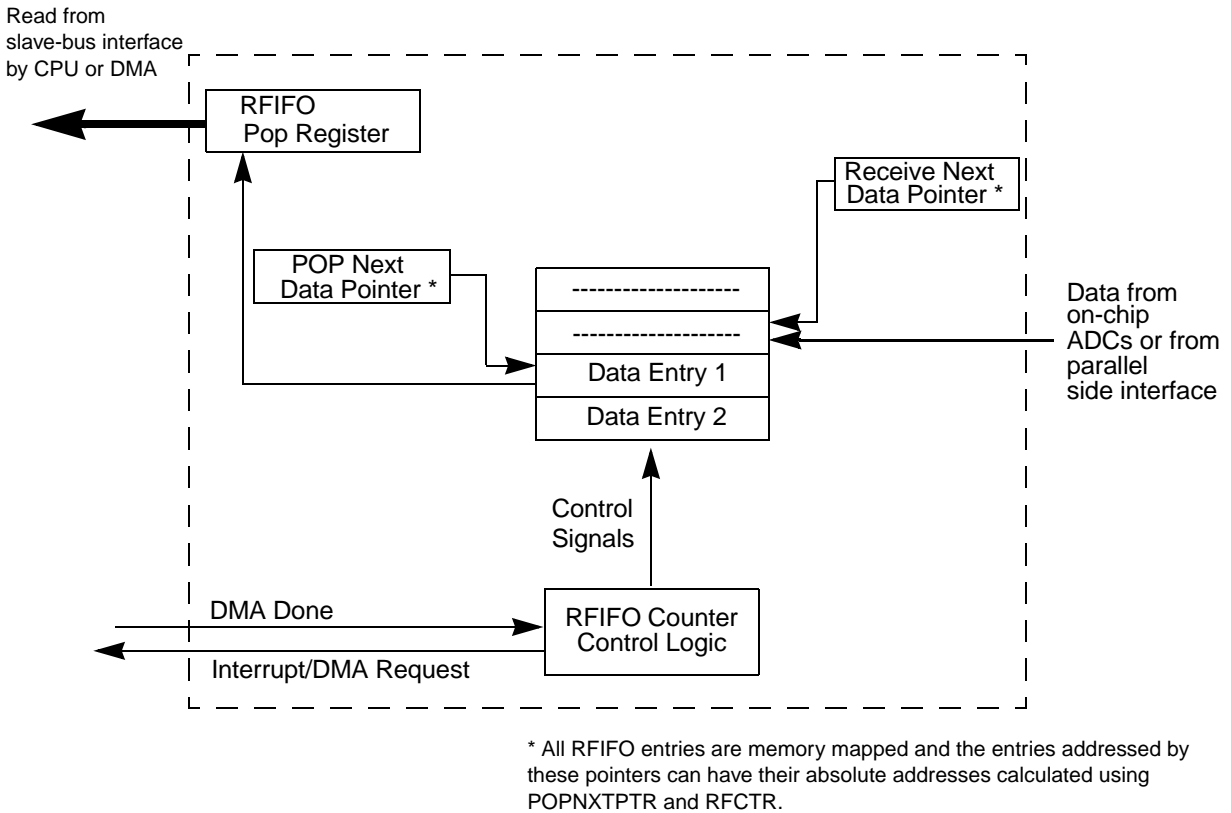
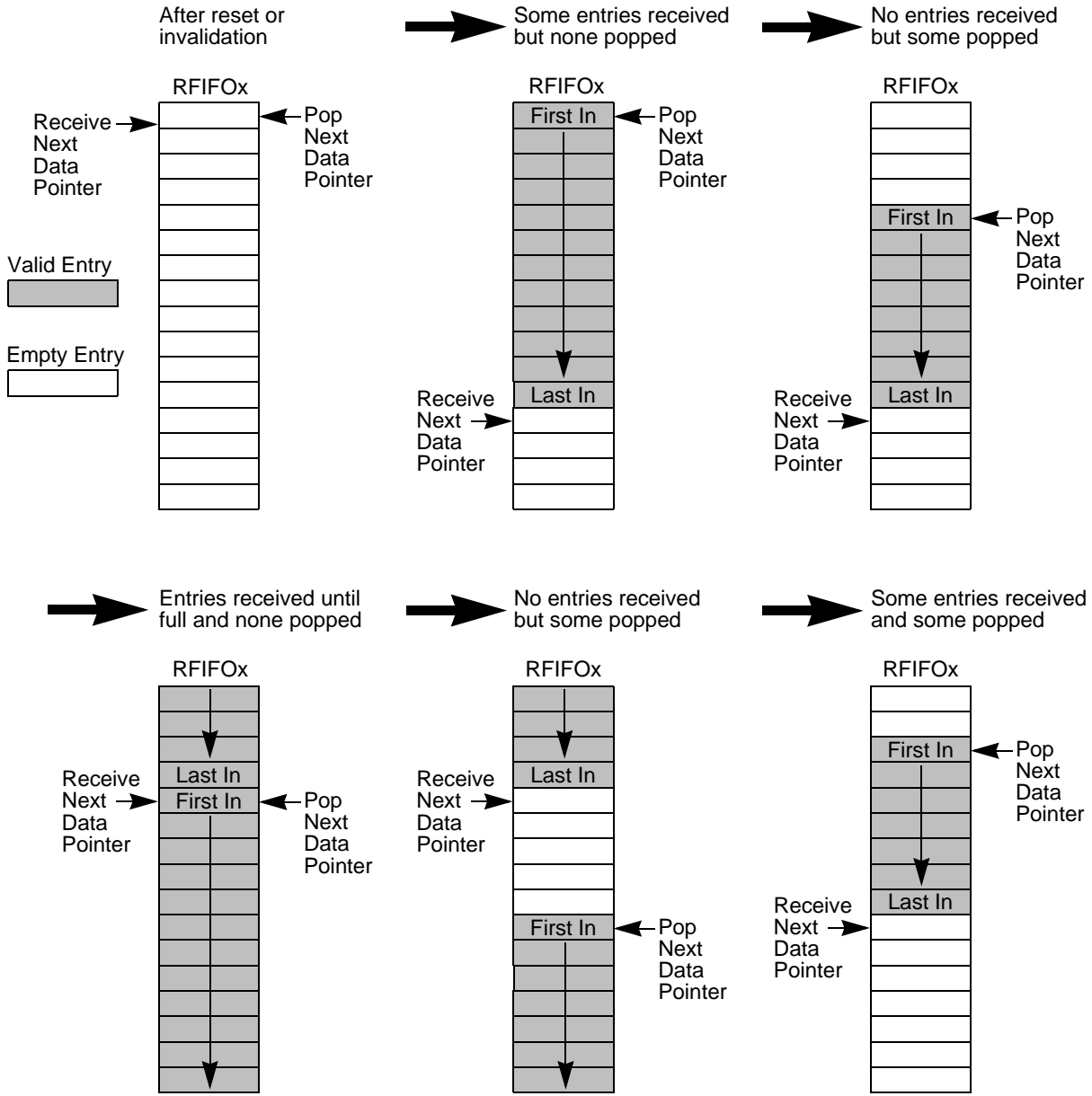

Figure 27-60. RFIFO Diagram

The detailed behavior of the Pop Next Data Pointer and Receive Next Data Pointer is described in the example shown in [Figure 27-61](#) where an RFIFO with 16 entries is shown for clarity of explanation, the actual hardware implementation has only four entries. In this example, RFIFOx with 16 entries is shown in sequence after popping or receiving entries.



NOTE: x=0, 1, 2, 3, 4, 5

Figure 27-61. RFIFO Entry Pointer Example

27.7.5.2 Distributing Result Data into RFIFOs

Data to be moved into the RFIFOs can come from these sources: ADC0, ADC1, or the on-chip companion module through the PSI. All result data comes with a MESSAGE_TAG field and a DEST field defining

what should be done with the received data. The EQADC hardware decodes the MESSAGE_TAG and DEST fields and:

- stores the 16-bit data into the appropriate RFIFO if the MESSAGE_TAG indicates a valid RFIFO number and DEST value is zero, or;
- sends the 16-bit data, the MESSAGE_TAG and the non-zero DEST data through the PSI to an on-chip companion module (as a decimation filter), or;
- ignores the data in case of a null or “reserved for customer use” MESSAGE_TAG and DEST value is zero.

In general received data is moved into RFIFOs as they become available, while an exception happens when multiple results from different sources become available at the same time. In that case, result data from ADC0 is processed first, result data from ADC1 is only process after all ADC0 data is processed, and finally returned data from the companion module is processed (after all data from ADC0/1 is processed).

When time-stamped results return from the on-chip ADCs, the conversion result and the time stamp are always moved to the RFIFOs in consecutive clock cycles in order to guarantee they are always stored in consecutive RFIFO entries.

27.7.6 On-Chip ADC Configuration and Control

27.7.6.1 Enabling and Disabling the On-chip ADCs

The on-chip ADCs have an enable bit (ADC0/1_EN) in the [Section 27.6.3.1, ADC0/1 Control Registers \(ADC0_CR and ADC1_CR\)](#), which allows the enabling of the ADCs only when necessary. When the enable bit for an ADC is negated, the clock input to that ADC is stopped. The ADCs are disabled out of reset - ADC0/1_EN bits are negated - to allow for their safe configuration. The ADC must only be configured when its enable bit is negated. Once the enable bit of an ADC is asserted, clock input to is started.

NOTE

Conversion commands sent to the CBuffer of a disabled ADC are ignored by the ADC control hardware.

NOTE

A 8ms wait time from VDDA power up to enabling ADC is required to pre-charge the external 100nf capacitor on REFBYPC pin. This time must be guaranteed by crystal startup time plus reset duration or user. The ADC internal bias generator circuit will start up after 10us upon VRH/VRL and VDDA/VSSA power up and produces a stable/required bias current to the pre-charge circuit, but the current to other analog circuits are disabled until ADCs are enabled. As soon as the ADCs are enabled, the bias currents to all of analog circuits will be enabled.

NOTE

Due to legacy reasons, the EQADC will always wait 120 ADC clocks before issuing the first conversion command following the enabling of one of on-chip ADCs, or the exiting of stop mode. There are two independent counters checking for this delay: one clocked by ADC0_CLK and another by ADC1_CLK. Conversion commands can start to be executed whenever one of these counters completes counting 120 ADC clocks.

27.7.6.2 ADC Clock and Conversion Speed

The clock input to the ADCs is defined by setting the ADC0/1_CLK_SEL and the ADC0/1_CLK_PS fields in the ADC0_CR and ADC1_CR. When the ADC0/1_CLK_SEL is set, the ADC clock frequency is the same as the platform clock, but it has the inverted phase. When it is clear, the ADC0/1_CLK_PS field selects the clock divide factor by which the platform clock will be divided as showed in [Table 27-22](#). The ADC clock frequency is calculated as below and should be lower than the maximum value specified to the ADC analog block. This is also the maximum frequency of platform clock when the ADC0/1_CLK_SEL is asserted.

$$ADCClockFrequency = \frac{PlatformClockFrequency(MHz)}{PlatformClockDivideFactor}; (ADCClockFrequency \leq 15MHz)$$

Figure 27-62 depicts how the ADC clocks for ADC0 and ADC1 are generated.

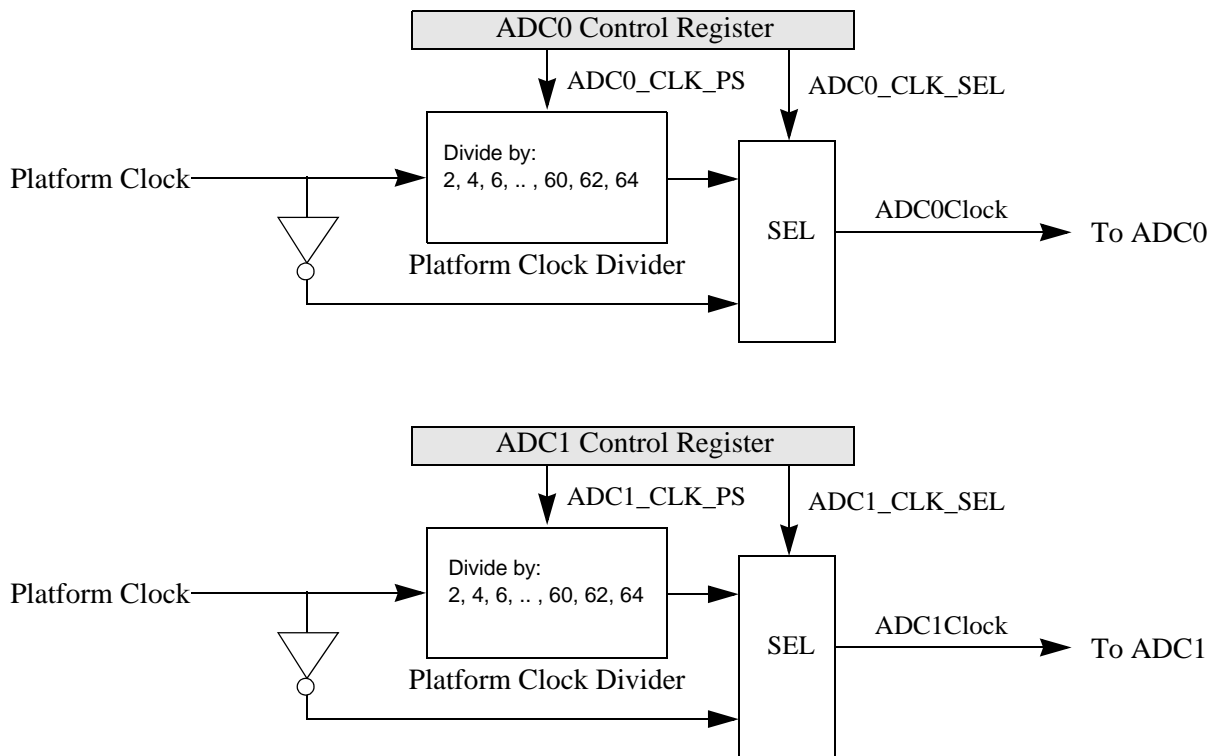

Figure 27-62. ADC0/1 Clock Generation

The ADC conversion speed (in K samples per second - Ksps) is calculated by the following formula. *The number of sampling cycles* is determined by the LST bits in the command message — see [Conversion Command Format for the Standard Configuration](#) — and it can take one of the following values: 2, 8, 64, or 128 ADC clock cycles. The *number of AD conversion cycles* is 13 for differential conversions and 14 for single-ended conversions (12 bits resolution and unitary input gain). The maximum conversion speed is achieved when the ADC Clock frequency is set to its maximum, the number of sampling cycles set to its minimum (2 cycles), and the resolution is also set to the minimum (8 bits) with input unitary gain.

$$ADCConversionSpeed = \frac{ADCClockFrequency(MHz)}{(NumberOfSamplingCycles + NumberOfADConversionCycles)}$$

Table 27-40 shows an example of how the ADC0/1_CLK_PS can be set when using a 120 MHz platform clock and the corresponding conversion speeds for all possible ADC clock frequencies. The table also shows that according to the platform clock frequency, certain clock divide factors are invalid (2, 4, 6, 8 clock divide factors in the example) since their use would result in a ADC clock frequency higher than the maximum one supported by the ADC. In this example, the maximum ADC clock frequency is 15 MHz (12 bits resolution conversions with unitary input gain).

Table 27-40. ADC Clock Configuration Example (Platform Clock Frequency=120 MHz)

| ADC0/1_CLK_PS[0:4] | Platform Clock Divide Factor | ADC Clock (Platform Clock = 120 MHz) | Differential Conversion Speed with Default Sampling Time (2 cycles) | Single-Ended Conversion Speed with Default Sampling Time (2 cycles) |
|--------------------|------------------------------|--------------------------------------|---|---|
| 0b00000 | 2 | N/A | N/A | N/A |
| 0b00001 | 4 | N/A | N/A | N/A |
| 0b00010 | 6 | N/A | N/A | N/A |
| 0b00011 | 8 | 15.0 MHz | 1.0 Msps | 938 Ksps |
| 0b00100 | 10 | 12.0 MHz | 800 Ksps | 750 Ksps |
| 0b00101 | 12 | 10.0 MHz | 667 Ksps | 625 Ksps |
| 0b00110 | 14 | 8.57 MHz | 571 Ksps | 536 Ksps |
| 0b00111 | 16 | 7.5 MHz | 500 Ksps | 469 Ksps |
| 0b01000 | 18 | 6.67 MHz | 444 Ksps | 417 Ksps |
| 0b01001 | 20 | 6.0 MHz | 400 Ksps | 375 Ksps |
| 0b01010 | 22 | 5.45 MHz | 364 Ksps | 341 Ksps |
| 0b01011 | 24 | 5.0 MHz | 333 Ksps | 313 Ksps |
| 0b01100 | 26 | 4.62 MHz | 308 Ksps | 288 Ksps |
| 0b01101 | 28 | 4.29 MHz | 286 Ksps | 268 Ksps |
| 0b01110 | 30 | 4.0 MHz | 267 Ksps | 250 Ksps |
| 0b01111 | 32 | 3.75 MHz | 250 Ksps | 234 Ksps |
| 0b10000 | 34 | 3.53 MHz | 235 Ksps | 221 Ksps |
| 0b10001 | 36 | 3.33 MHz | 222 Ksps | 208 Ksps |
| 0b10010 | 38 | 3.16 MHz | 211 Ksps | 198 Ksps |
| 0b10011 | 40 | 3.0 MHz | 200 Ksps | 188 Ksps |
| 0b10100 | 42 | 2.86 MHz | 190 Ksps | 179 Ksps |
| 0b10101 | 44 | 2.73 MHz | 182 Ksps | 170 Ksps |

Table 27-40. ADC Clock Configuration Example (Platform Clock Frequency=120 MHz) (continued)

| ADC0/1_CLK_PS[0:4] | Platform Clock Divide Factor | ADC Clock (Platform Clock = 120 MHz) | Differential Conversion Speed with Default Sampling Time (2 cycles) | Single-Ended Conversion Speed with Default Sampling Time (2 cycles) |
|--------------------|------------------------------|--------------------------------------|---|---|
| 0b10110 | 46 | 2.61 MHz | 174 Ksps | 163 Ksps |
| 0b10111 | 48 | 2.5 MHz | 167 Ksps | 156 Ksps |
| 0b11000 | 50 | 2.4 MHz | 160 Ksps | 150 Ksps |
| 0b11001 | 52 | 2.31 MHz | 154 Ksps | 144 Ksps |
| 0b11010 | 54 | 2.22 MHz | 148 Ksps | 139 Ksps |
| 0b11011 | 56 | 2.14 MHz | 143 Ksps | 134 Ksps |
| 0b11100 | 58 | 2.07 MHz | 138 Ksps | 129 Ksps |
| 0b11101 | 60 | 2.0 MHz | 133 Ksps | 125 Ksps |
| 0b11110 | 62 | 1.94 MHz | 129 Ksps | 121 Ksps |
| 0b11111 | 64 | 1.88 MHz | 125 Ksps | 117 Ksps |

27.7.6.3 Time Stamp Feature

The on-chip ADCs can provide a time stamp for the conversions they execute. A time stamp is the value of the time base counter latched when the EQADC detects the end of the analog input voltage sampling. A time stamp for a conversion command is requested by setting the TSR bit in the corresponding command. When TSR is negated, that is a time stamp is not requested, the ADC returns a single result message containing the conversion result. When TSR is asserted, that is a time stamp is requested, the ADC returns two result messages; one containing the conversion result, and afterwards another containing the time stamp for that conversion. The result messages are sent in this order to the RFIFOs and both messages are sent to the same RFIFO was specified in the MESSAGE_TAG field of the executed conversion command.

The time base counter is a 16-bit up counter that wraps after reaching 0xFFFF. It is disabled after reset and it is enabled according to the setting of TBC_CLK_PS field in [Section 27.6.3.2, ADC Time Stamp Control Register \(ADC_TSCR\)](#). TBC_CLK_PS defines if the counter is enabled or disabled, and, if enabled, at what frequency it is incremented. The time stamps are returned regardless of whether the time base counter is enabled or disabled. The time base counter can be reset by writing 0x0000 to the [Section 27.6.3.3, ADC Time Base Counter Registers \(ADC_TBCR\)](#), with a write configuration command.

27.7.6.4 ADC Pre-gain Feature

Each ADC can be configured to have a selectable input gain as defined in [Section 27.6.3.6, Alternate Configuration 1-8 Control Registers \(ADC_ACR1-8\)](#). This means the input signal is sampled and the result is amplified by factor 2, or 4 before the conversion phase. In present implementation of this feature, the conversion is 1 or 2 ADC clock cycles longer for gain 2 or gain 4, respectively.

27.7.6.5 ADC Resolution Selection Feature

The ADCs conversion resolutions can be 8 bits, 10 bits or 12 bits as described in [Section 27.6.3.6, Alternate Configuration 1-8 Control Registers \(ADC_ACR1-8\)](#). For conversions at a resolution less than 12, the ADC is executing less operations and the conversion time is smaller. In this ADC, it is verified that

there is 1 ADC clock cycle for each bit of resolution. Therefore, for the same ADC clock frequency, the ADC sample frequency is higher for lower resolutions.

27.7.6.6 ADC Calibration Feature

27.7.6.6.1 Overview

There are three sets of calibration coefficients for each ADC. Each set is composed by a gain factor and an offset factor: GCC_n/OCC_n, ALTGCC_{n1}/ALTGCC_{n1}, and ALTGCC_{n2}/ALTGCC_{n2}, where n is the ADC number 0 or 1. The pair GCC_n/OCC_n is selected when it is used the normal configuration or the alternate configurations 3 to 8. The pair ALTGCC_{n1}/ALTGCC_{n1} is used only when the alternate configuration 1 is selected. And the pair ALTGCC_{n2}/ALTGCC_{n2} is for the alternate configuration 2. The description below is for a generic pair of gain/offset GCC/OCC.

The EQADC provides a calibration scheme to remove the effects of gain and offset errors from the results generated by the on-chip ADCs. Only results generated by the on-chip ADCs are calibrated. The results generated by ADCs on the external device are directly sent to RFIFOs unchanged. The main component of calibration hardware is a Multiply-and-Accumulate (MAC) unit, one per on-chip ADC, that is used to calculate the following transfer function which relates a calibrated result to a raw, uncalibrated one.

$$\text{CAL_RES} = \text{GCC} * \text{RAW_RES} + \text{OCC} + 2;$$

where:

- CAL_RES is the calibrated result corresponding the input voltage V_i .
- GCC is the gain calibration constant.
- RAW_RES is the raw, uncalibrated result with resolution adjustment corresponding to an specific input voltage V_i .
- OCC is the offset calibration constant.
- The addition of two reduces the maximum quantization error of the ADC. See [Section 27.8.6.3, Quantization Error Reduction During Calibration](#).

Calibration constants GCC and OCC are determined by taking two samples of known reference voltages and using these samples to calculate the values for the constants. For details and an example about how to calculate the calibration constants and use them in result calibration refer to [Section 27.8.6, ADC Result Calibration](#). Once calculated, GCC is stored in the [Section 27.6.3.4, ADC0/1 Gain Calibration Constant Registers \(ADC0_GCCR and ADC1_GCCR\)](#), and OCC in [Section 27.6.3.5, ADC0/1 Offset Calibration Constant Registers \(ADC0_OCCR and ADC1_OCCR\)](#), from where their values are fed to the MAC unit. The alternate gain values are stored in [Section 27.6.3.7, ADC0/1 Alternate Gain Registers \(ADC0_AGR1-2 and ADC1_AGR1-2\)](#), and the alternate offset values in [Section 27.6.3.8, ADC0/1 Alternate Offset Register \(ADC0_AOR1-2 and ADC1_AOR1-2\)](#). Since the analog characteristics of each on-chip ADCs differs, each ADC has an independent pair of calibration constants.

A conversion result is calibrated according to the status of CAL bit in the command that initiated the conversion. If the CAL bit is asserted, the EQADC will automatically calculate the calibrated result before sending the result to the appropriate RFIFO or companion module. If the CAL bit is negated, the result is not calibrated, it bypasses the calibration hardware, and is directly sent to the appropriate RFIFO or companion module.

27.7.6.6.2 MAC Unit and Operand Data Format

The MAC unit diagram is shown in [Figure 27-63](#). Each on-chip ADC has a separate MAC unit to fine-tune its conversion results. The description below considers the general calibration constant registers but it is the same for the alternate calibration constants.

The OCC0/1 operand is a 14-bit signed value stored in the [Section 27.6.3.5, ADC0/1 Offset Calibration Constant Registers \(ADC0_OCCR and ADC1_OCCR\)](#). The RAW_RES operand is the raw uncalibrated result, and it is the direct output from the on-chip ADCs but passing through the resolution adjustment block. The GCC0/1 operand is a 15-bit fixed point unsigned value stored in the [Section 27.6.3.4, ADC0/1 Gain Calibration Constant Registers \(ADC0_GCCR and ADC1_GCCR\)](#). The GCC is expressed in the *GCC_INT.GCC_FRAC* binary format. The integer part of the GCC ($GCC_INT = GCC[1]$) contains a single binary digit while its fractional part ($GCC_FRAC = GCC[2:15]$) contains 14 bits - see [Figure 27-64](#). The gain constant equivalent decimal value ranges from 0 to 1.999938..., as shown in [Table 27-41](#). Two is always added to the MAC output - see [Section 27.8.6.3, Quantization Error Reduction During Calibration](#). CAL_RES output is the calibrated result, and it is a 14-bit unsigned value. CAL_RES is truncated to 0x3FFF, in case of a overflow, and to 0x0000, in case of an underflow.

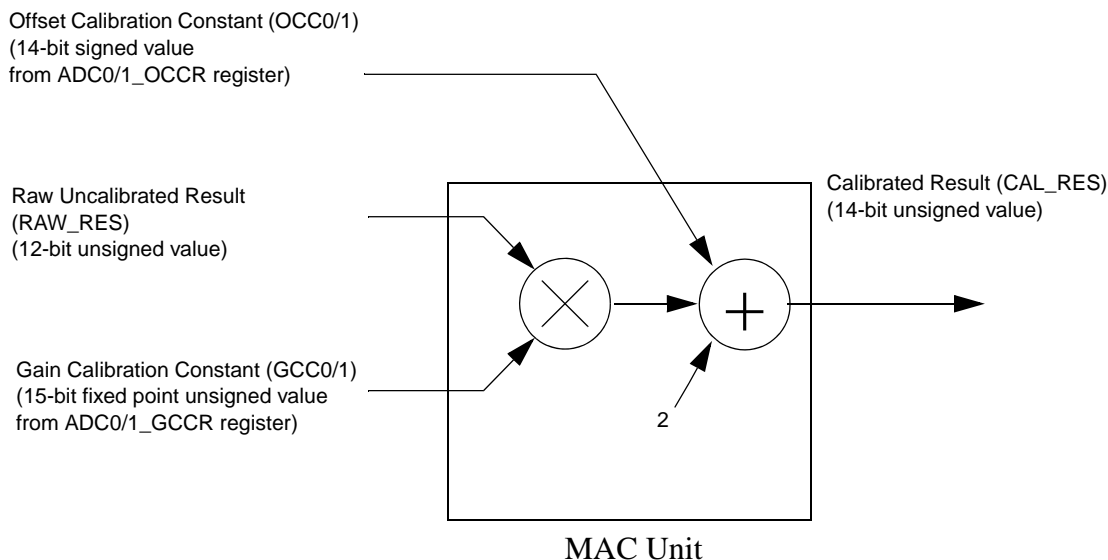

Figure 27-63. MAC Unit Diagram

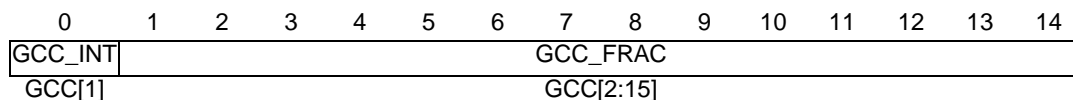

Figure 27-64. Gain Calibration Constant Format

GCC_INT - Integer part of the gain calibration constant for ADC0/1

GCC_INT is the integer part of the gain calibration constant for ADC0/1.

GCC_FRAC[1:14] - Fractional part of the gain calibration constant for ADC0/1

GCC_FRAC is the fractional part of the gain calibration constant for ADC0/1. GCC_FRAC can express decimal values ranging from 0 to 0.999938...

Table 27-41. Binary and Decimal Representations of the Gain Constant

| Gain Constant (GCC_INT.GCC_FRAC binary format) | Corresponding Decimal Value |
|---|-----------------------------|
| 0.0000_0000_0000_00 | 0 |
| ... | ... |
| 0.1000_0000_0000_00 | 0.5 |
| ... | ... |
| 0.1111_1111_1111_11 | 0.999938... |
| 1.0000_0000_0000_00 | 1 |
| ... | ... |
| 1.1100_0000_0000_00 | 1.75 |
| ... | ... |
| 1.1111_1111_1111_11 | 1.999938... |

27.7.6.7 ADC Control Logic overview and command execution

Figure 27-65 shows the basic logic blocks involved in the ADC Control and how they interact. CFIFOs/RFIFOs interact with CBuffers/*Abort Cont/Result Message Return Logic* through the *FIFO Control Unit*. The EB and BN bits in the Command Message uniquely identify the CBuffer to which a command should be sent. The *FIFO Control Unit* decodes these bits and sends the ADC command to the proper CBuffer. Other blocks of logic are the *Resolution Adjustment, Result Format and Calibration Sub-Block*, the *Time Stamp Logic*, and the *MUX Control Logic*.

The *Resolution Adjustment Sub-Block* receives the 12-bit data bus directly from the ADC and changes the received conversion results from right aligned format of ADC to the left aligned format depending on the selected resolution of the conversion. This operation helps the calibration processing to use the calibration coefficients always with the same format.

The *Result Format and Calibration Sub-Block* formats the returning data into Result Messages and sends them to the RFIFOs¹. The returning data can be data read from an ADC register, a conversion result, or a time stamp. The formatting and calibration of conversion results also take place inside this sub-block.

The *Time Stamp Logic* latches the value of the time base counter when detecting the end of the analog input voltage sampling, and sends it to the *Result Format and Calibration Sub-Block* as time stamp information.

The *MUX Control Logic* generates the proper MUX control signals and, when the ADC0/1_EMUX bits are asserted, the MA signals based on the channel numbers extracted from the ADC Command.

When the on-chip ADC abort feature is not enabled, ADC Commands are stored in the CBuffers as they come and they are executed in the first-in-first-out basis. After the execution of a command in ENTRY1 finishes all commands are shifted one entry. After the shift, ENTRY0 is always empty and ready to receive a new command. Execution of configuration commands only start when they reach ENTRY1. Consecutive conversion commands are pipelined and their execution can start while in ENTRY0. This is explained below.

1. The result messages may also be routed to an on-chip companion module via the side interface, and then fed back to the RFIFOs.

AD conversion accuracy can be affected by the settling time of the input channel multiplexers. Some time is required for the channel multiplexers internal capacitances to settle after the channel number is changed. If the time prior to sampling is not long enough to absorb this settling, then the settling time will take from ADC sampling time which may result in inaccurate sampling and ultimately compromise conversion result accuracy - see [Figure 27-66 \(a\)](#). The EQADC attempts to compensate for this settling time by switching the multiplexers in preparation for the next conversion command's sampling while performing the previous conversion ([Figure 27-66 \(b\)](#)). In EQADC, this is done in the following way; when a conversion command is in buffer ENTRY1 and another conversion command is identified in ENTRY0, then the channel number of ENTRY0 is sent to the *MUX Control Logic* some cycles before the sampling phase of the command in ENTRY0 starts. In this way, sampling for the next command can promptly start after the current conversion finishes because the internal capacitance of the multiplexers will be settled by that time, allowing for more accurate sampling. This is specially important for applications that require high conversion speeds, that is with the ADC running at maximum clock frequency and with the analog input voltage sampling time set to a minimum (2 ADC clock cycles), when the short sampling time does not allow the multiplexers to completely settle. The second advantage of pipelining conversion commands is to provide precise conversion intervals, which means the time intervals between two consecutive conversions are the same. This is important for any digital signal process application.

When the on-chip ADC abort feature is enabled, ADC Commands from CFIFO0 should be considered immediately, even stopping the execution of some command that is already in ENTRY1. When the abort request is sent to the ADC, the already stored commands in the CBuffers are copied in a temporary set of registers. The first ADC command from CFIFO0 is sent after the abort acknowledge indication from ADC. The process is the same as usual until the transfer of the last command from CFIFO0. Then the temporarily stored commands that were postponed by the abortion are recovered and they are pipelined for execution. After the last command from this temporary memory is transferred, the next commands are pipelined from the CFIFOs.

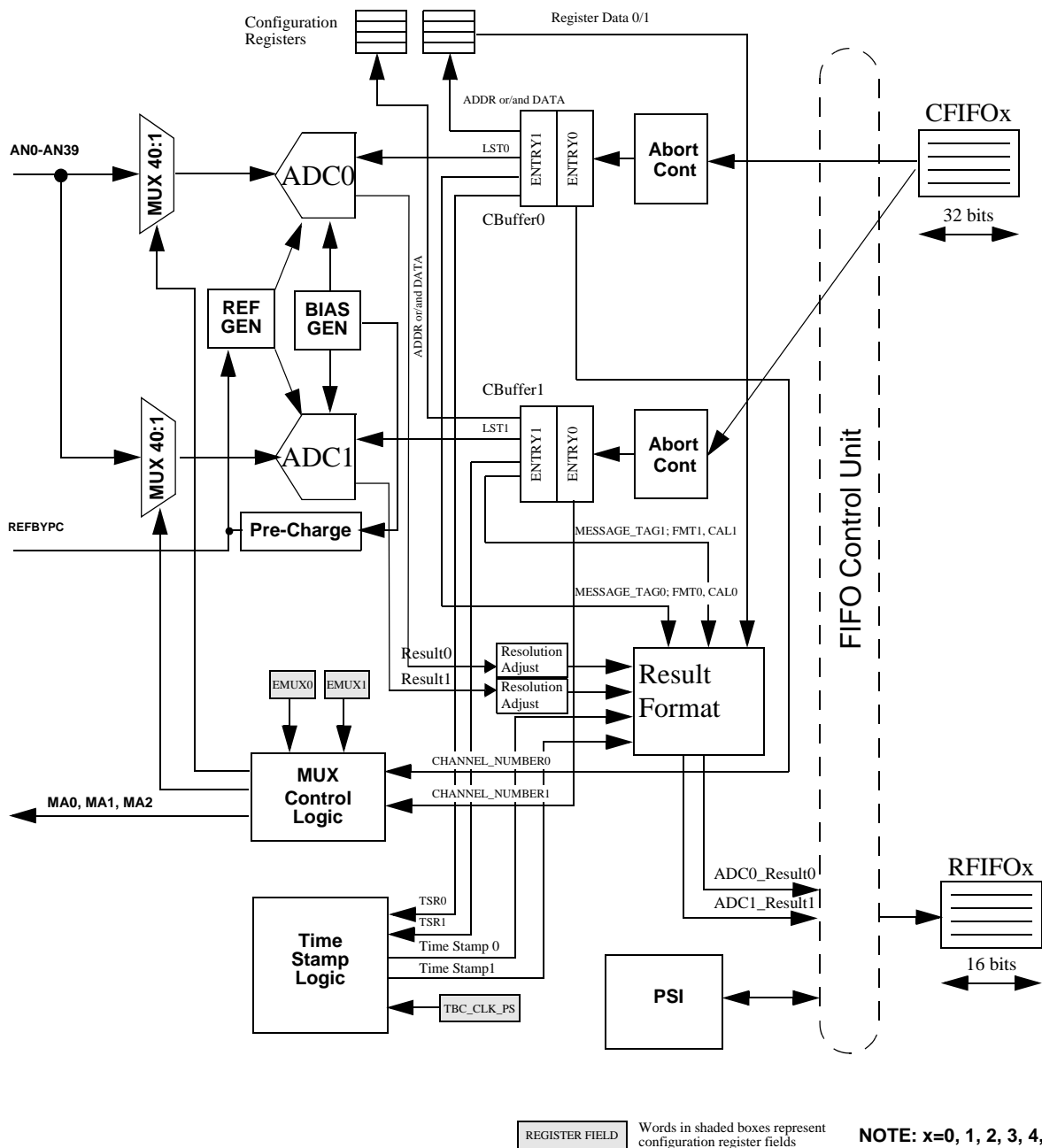
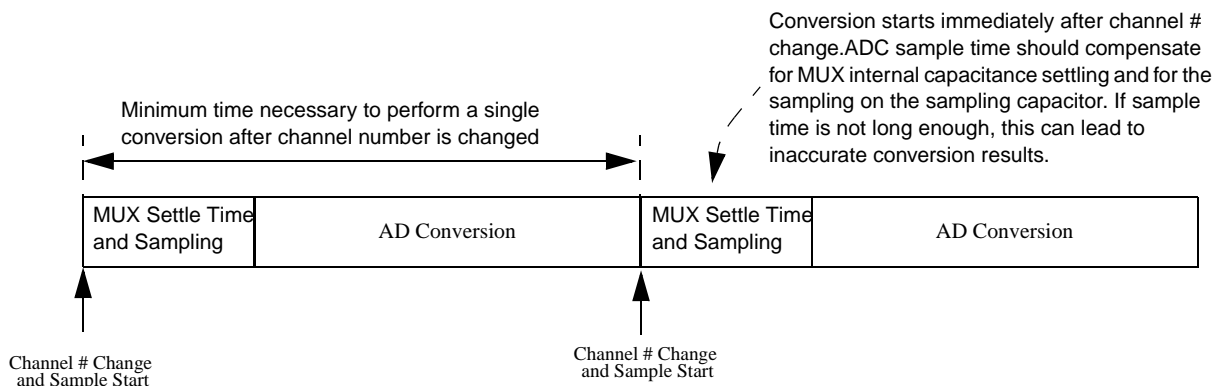
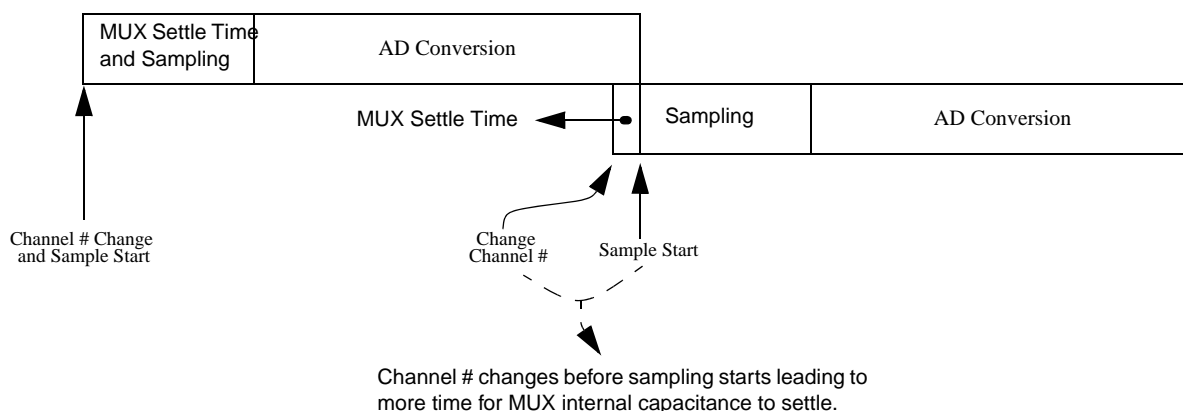

Figure 27-65. On-Chip ADC Control Scheme



(a) Command Execution Sequence for Two Non-Overlapped Commands



(b) Command Execution Sequence for Two Overlapped Commands

Figure 27-66. Overlapping Consecutive Conversion Commands

27.7.7 Internal/External Multiplexing

27.7.7.1 Channel Assignment

The internal analog multiplexers select one of the 40 analog input pins for conversion, based on the CHANNEL_NUMBER field of a Command Message. The analog input pin channel number assignments and the pin definitions vary depending on how the ADC0/1_EMUX are configured. Allowed combinations of ADC0/1_EMUX bits are shown in Table 27-42 together with references to tables indicating how CHANNEL_NUMBER field of each conversion command must be set to avoid channel selection conflicts. In addition to this master multiplexer, each ADC is equipped with a secondary multiplexer that are used to monitor signals internal to the chip. These analog input pins are also selected by the CHANNEL_NUMBER field.

During differential conversions the analog multiplexer passes differential signals to both the positive and negative terminals of the ADC. The differential conversions can only be initiated on four channels: DAN0, DAN1, DAN2, and DAN3. For each value of CHANNEL_NUMBER, this table lists the ADCs you can use to perform conversions for that channel (which you specify using BN), whether external multiplexing (specified by ADCx_CR[EMUX]) must be disabled or enabled to access the channel, and the assigned analog input signal and conversion type.

- More than one ADC can access the same analog input, but not at the same time.
- When one ADC is performing a differential conversion on a pair of pins, another ADC must not access either of those two pins as single-ended channels.

Table 27-42. Multiplexed and non-multiplexed channel assignments

| CHANNEL_NUMBER | | ADCs (BN) | ADCx_CR[EMUX] | Analog input signal | Conversion type |
|------------------------|----------|-----------|---------------|--|-----------------|
| (b) | (d) | | | | |
| 0000_0000 | 0 | 0, 1 | X | AN0 (accessible when DAN0+ and DAN0– are not being accessed) | Single-ended |
| 0000_0001 | 1 | 0, 1 | X | AN1 (accessible when DAN0+ and DAN0– are not being accessed) | Single-ended |
| 0000_0010 | 2 | 0, 1 | X | AN2 (accessible when DAN1+ and DAN1– are not being accessed) | Single-ended |
| 0000_0011 | 3 | 0, 1 | X | AN3 (accessible when DAN1+ and DAN1– are not being accessed) | Single-ended |
| 0000_0100 | 4 | 0, 1 | X | AN4 (accessible when DAN2+ and DAN2– are not being accessed) | Single-ended |
| 0000_0101 | 5 | 0, 1 | X | AN5 (accessible when DAN2+ and DAN2– are not being accessed) | Single-ended |
| 0000_0110 | 6 | 0, 1 | X | AN6 (accessible when DAN3+ and DAN3– are not being accessed) | Single-ended |
| 0000_0111 | 7 | 0, 1 | X | AN7 (accessible when DAN3+ and DAN3– are not being accessed) | Single-ended |
| 0000_1000 | 8 | 0, 1 | X | AN8 (see also ANW) | Single-ended |
| 0000_1001 | 9 | 0, 1 | X | AN9 (see also ANX) | Single-ended |
| 0000_1010 | 10 | 0, 1 | X | AN10 (see also ANY) | Single-ended |
| 0000_1011 | 11 | 0, 1 | X | AN11 (see also ANZ) | Single-ended |
| 0000_1100 to 0000_1111 | 12 to 15 | 0, 1 | X | AN12 to AN15 | Single-ended |
| 0001_0000 | 16 | 0, 1 | X | AN16 (see also ANR) | Single-ended |
| 0001_0001 | 17 | 0, 1 | X | AN17 (see also ANS) | Single-ended |
| 0001_0010 | 18 | 0, 1 | X | AN18 (see also ANT) | Single-ended |
| 0001_0011 | 19 | 0, 1 | X | AN19 (see also ANU) | Single-ended |

Table 27-42. Multiplexed and non-multiplexed channel assignments (continued)

| CHANNEL_NUMBER | | ADCs (BN) | ADCx_CR[EMUX] | Analog input signal | Conversion type |
|------------------------|------------|------------|---------------|---|-----------------|
| (b) | (d) | | | | |
| 0001_0100 to 0010_0111 | 20 to 39 | 0, 1 | X | AN20 to AN39 | Single-ended |
| 0010_1000 | 40 | 0, 1 | X | VRH | Single-ended |
| 0010_1001 | 41 | 0, 1 | X | VRL | Single-ended |
| 0010_1010 | 42 | 0, 1 | X | $50\% \times (VRH - VRL)$ (do not use for calibration) | Single-ended |
| 0010_1011 | 43 | 0, 1 | X | $75\% \times (VRH - VRL)$ (used for calibration) | Single-ended |
| 0010_1100 | 44 | 0, 1 | X | $25\% \times (VRH - VRL)$ (used for calibration) | Single-ended |
| 0010_1101 | 45 | 0 | X | INA_ADC0_0 (see Table 27-4) | Single-ended |
| 0010_1101 | 45 | 1 | X | INA_ADC1_0 (see Table 27-4) | Single-ended |
| 0010_1110 to 0011_1111 | 46 to 63 | (Reserved) | | | |
| 0100_0xxx | 64 to 71 | 0, 1 | 1 | ANW (the MA2–MA0 pins act as the selector inputs for an external 8-to-1 mux; see also AN8) | Single-ended |
| 0100_1xxx | 72 to 79 | 0, 1 | 1 | ANX (the MA2–MA0 pins act as the selector inputs for an external 8-to-1 mux; see also AN9) | Single-ended |
| 0101_0xxx | 80 to 87 | 0, 1 | 1 | ANY (the MA2–MA0 pins act as the selector inputs for an external 8-to-1 mux; see also AN10) | Single-ended |
| 0101_1xxx | 88 to 95 | 0, 1 | 1 | ANZ (the MA2–MA0 pins act as the selector inputs for an external 8-to-1 mux; see also AN11) | Single-ended |
| 0110_0000 | 96 | 0, 1 | X | DAN0+ and DAN0– (accessible when A0 and A1 are not being accessed) | Differential |
| 0110_0001 | 97 | 0, 1 | X | DAN1+ and DAN1– (accessible when A2 and A3 are not being accessed) | Differential |
| 0110_0010 | 98 | 0, 1 | X | DAN2+ and DAN2– (accessible when A4 and A5 are not being accessed) | Differential |
| 0110_0011 | 99 | 0, 1 | X | DAN3+ and DAN3– (accessible when A6 and A7 are not being accessed) | Differential |
| 0110_0100 to 0111_1111 | 100 to 127 | (Reserved) | | | |
| 1000_0000 | 128 | 0 | X | INA_ADC0_1 (see Table 27-4) | Single-ended |
| 1000_0000 | 128 | 1 | X | INA_ADC1_1 (see Table 27-4) | Single-ended |
| 1000_0001 | 129 | 0 | X | INA_ADC0_2 (see Table 27-4) | Single-ended |
| 1000_0001 | 129 | 1 | X | INA_ADC1_2 (see Table 27-4) | Single-ended |

Table 27-42. Multiplexed and non-multiplexed channel assignments (continued)

| CHANNEL_NUMBER | | ADCs (BN) | ADCx_CR[EMUX] | Analog input signal | Conversion type |
|------------------------|------------|------------|---------------|---|-----------------|
| (b) | (d) | | | | |
| 1000_0010 to 1000_1111 | 130 to 143 | (Reserved) | | | |
| 1001_0000 | 144 | 0 | X | INA_ADC0_9 (see Table 27-4) | Single-ended |
| 1001_0000 | 144 | 1 | X | INA_ADC1_9 (see Table 27-4) | Single-ended |
| 1001_0001 to 1010_0001 | 145 to 161 | (Reserved) | | | |
| 1010_0010 | 162 | X | 0 | INA_ADC0_3 (see Table 27-4) | Single-ended |
| 1010_0011 | 163 | X | 0 | INA_ADC0_4 (see Table 27-4) | Single-ended |
| 1010_0100 | 164 | X | 0 | INA_ADC0_5 (see Table 27-4) | Single-ended |
| 1010_0101 | 165 | X | 0 | INA_ADC0_6 (see Table 27-4) | Single-ended |
| 1010_0110 | 166 | X | 0 | INA_ADC0_7 (see Table 27-4) | Single-ended |
| 1010_0111 | 167 | X | 0 | INA_ADC0_8 (see Table 27-4) | Single-ended |
| 1010_1000 to 1100_0001 | 168 to 193 | (Reserved) | | | |
| 1100_0010 | 194 | X | 0 | INA_ADC1_3 (see Table 27-4) | Single-ended |
| 1100_0011 | 195 | X | 0 | INA_ADC1_4 (see Table 27-4) | Single-ended |
| 1100_0100 | 196 | X | 0 | INA_ADC1_5 (see Table 27-4) | Single-ended |
| 1100_0101 | 197 | X | 0 | INA_ADC1_6 (see Table 27-4) | Single-ended |
| 1100_0110 | 198 | X | 0 | INA_ADC1_7 (see Table 27-4) | Single-ended |
| 1100_0111 | 199 | X | 0 | INA_ADC1_8 (see Table 27-4) | Single-ended |
| 1100_1000 to 1101_1111 | 200 to 223 | (Reserved) | | | |
| 1110_0xxx | 224 to 231 | 0, 1 | 1 | ANR (the MA2–MA0 pins act as the selector inputs for an external 8-to-1 mux; see also AN16) | Single-ended |
| 1110_1xxx | 232 to 239 | 0, 1 | 1 | ANS (the MA2–MA0 pins act as the selector inputs for an external 8-to-1 mux; see also AN17) | Single-ended |
| 1111_0xxx | 240 to 247 | 0, 1 | 1 | ANT (the MA2–MA0 pins act as the selector inputs for an external 8-to-1 mux; see also AN18) | Single-ended |
| 1111_1xxx | 248 to 255 | 0, 1 | 1 | ANU (the MA2–MA0 pins act as the selector inputs for an external 8-to-1 mux; see also AN19) | Single-ended |

27.7.7.2 External Multiplexing

The EQADC can use from one to eight external multiplexer chips to expand the number of analog signals that may be converted. Up to 64 analog channels can be converted through external multiplexer selection.

The externally multiplexed channels are automatically selected by the CHANNEL_NUMBER field of a Command Message, in the same way done with internally multiplexed channels. The software selects the external multiplexed mode by setting the ADC0/1_EMUX bit in either ADC0_CR or ADC1_CR depending on which ADC will perform the conversion. Table 27-43 shows the channel number assignments for the multiplexed mode. There are 4 differential pairs, 39 single-ended, and, at most, 64 externally multiplexed channels which can be selected. Only one ADC can have its EMUX bit asserted at a time.

Figure 27-67 shows the maximum configuration of eight external multiplexer chips connected to the EQADC. The external multiplexer chip selects one of eight analog inputs and connects it to a single analog output, which is fed to a specific input of the EQADC. The EQADC provides three multiplexed address signals, MA0, MA1, and MA2, to select one of eight inputs. These three multiplexed address signals are connected to all eight external multiplexer chips. The analog output of the eight multiplex chips are each connected to eight separate EQADC inputs, ANR, ANS, ANT, ANU, ANW, ANX, ANY, and ANZ. The MA pins correspond to the three least significant bits of the channel number that selects ANR, ANS, ANT, ANU, ANW, ANX, ANY, and ANZ with MA0 being the most significant bit - See Table 27-43.

Table 27-43. Encoding of MA Pins¹

| Channel Number selecting ANR, ANS, ANT, ANU, ANW, ANX, ANY, ANZ (decimal) | | | | | | | | MA0 | MA1 | MA2 |
|--|-----|-----|-----|-----|-----|-----|-----|-----|-----|-----|
| ANR | ANS | ANT | ANU | ANW | ANX | ANY | ANZ | | | |
| 224 | 232 | 240 | 248 | 64 | 72 | 80 | 88 | 0 | 0 | 0 |
| 225 | 233 | 241 | 249 | 65 | 73 | 81 | 89 | 0 | 0 | 1 |
| 226 | 234 | 242 | 250 | 66 | 74 | 82 | 90 | 0 | 1 | 0 |
| 227 | 235 | 243 | 251 | 67 | 75 | 83 | 91 | 0 | 1 | 1 |
| 228 | 236 | 244 | 252 | 68 | 76 | 84 | 92 | 1 | 0 | 0 |
| 229 | 237 | 245 | 253 | 69 | 77 | 85 | 93 | 1 | 0 | 1 |
| 230 | 238 | 246 | 254 | 70 | 78 | 86 | 94 | 1 | 1 | 0 |
| 231 | 239 | 247 | 255 | 71 | 79 | 87 | 95 | 1 | 1 | 1 |

NOTES:

¹ '0' means pin is driven LOW and '1' that pin is driven HIGH.

When the external multiplexed mode is selected for either ADC, the EQADC automatically creates the MA output signals from CHANNEL_NUMBER field of a Command Message. The EQADC also converts the proper input channel (ANR, ANS, ANT, ANU, ANW, ANX, ANY, and ANZ) by interpreting the CHANNEL_NUMBER field. As a result, up to 64 externally multiplexed channels appear to the conversion queues as directly connected signals.

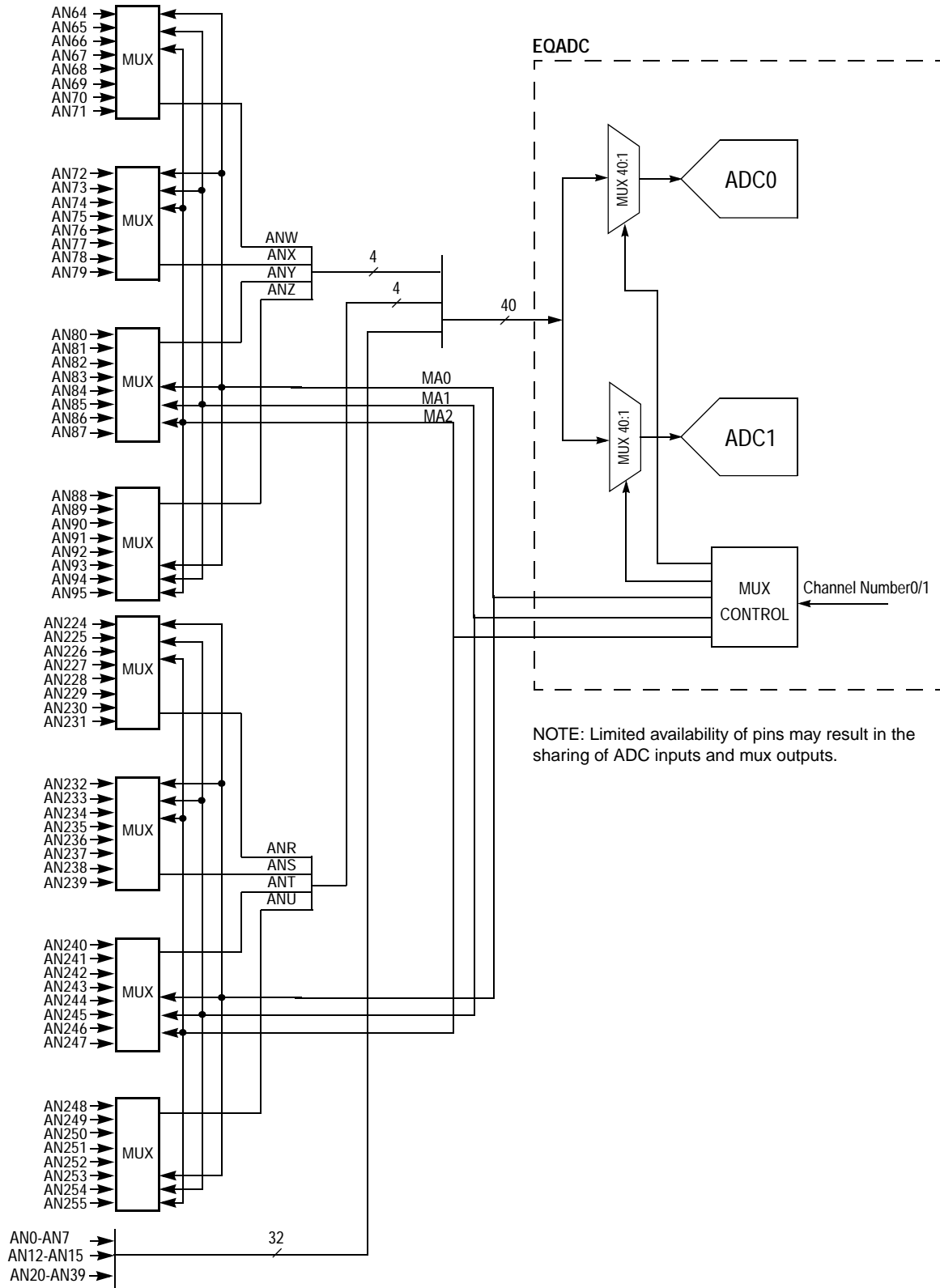

Figure 27-67. Example of External Multiplexing

27.7.8 EQADC DMA/Interrupt Request

Table 27-44 lists methods to generate interrupt requests in the EQADC queuing control and triggering control. The DMA/interrupt request select bits and the DMA/interrupt enable bits are described in Section 27.6.2.6, EQADC Interrupt and DMA Control Registers (EQADC_IDCR), and the interrupt flag bits are described in Section 27.6.2.7, EQADC FIFO and Interrupt Status Registers (EQADC_FISR).

Table 27-68 depicts all interrupts and DMA requests generated by the EQADC. The Result FIFO Overflow Interrupt, the Command FIFO Underflow Interrupt, and the Command FIFO Trigger Overrun Interrupt requests of ALL CFIFOs are ORed to generate single interrupt request from the eQADC. This combined interrupt request is asserted whenever one of the following flags becomes asserted: RFOF_x, CFUF_x, and TORF_x (assuming that all interrupts are enabled).

Table 27-44. EQADC FIFO Interrupt Summary¹

| Interrupt | Condition | Clearing Mechanism |
|---|---|--|
| Non Coherency Interrupt | NCIE _x = 1 NCF _x = 1 | Clear NCF _x bit by writing a “1” to the bit. |
| Result FIFO Overflow Interrupt ² | RFOIE _x = 1 RFOF _x = 1 | Clear RFOF _x bit by writing a “1” to the bit. |
| Command FIFO Underflow Interrupt ² | CFUIE _x = 1 CFUF _x = 1 | Clear CFUF _x bit by writing a “1” to the bit. |
| Result FIFO Drain Interrupt | RFDE _x = 1 RFDS _x = 0 RFDF _x = 1 | Clear RFDF _x bit by writing a “1” to the bit. |
| Command FIFO Fill Interrupt | CFFE _x = 1 CFFS _x = 0 CFFF _x = 1 | Clear CFFF _x bit by writing a “1” to the bit. |
| End of Queue Interrupt | EOQIE _x = 1 EOQF _x = 1 | Clear EOQF _x bit by writing a “1” to the bit. |
| Pause Interrupt | PIE _x = 1 PF _x = 1 | Clear PF _x bit by writing a “1” to the bit. |
| Trigger Overrun Interrupt ² | TORIE _x = 1 TORF _x = 1 | Clear TORF _x bit by writing a “1” to the bit. |

NOTES:

- ¹ For details refer to Section 27.6.2.7, EQADC FIFO and Interrupt Status Registers (EQADC_FISR), and Section 27.6.2.6, EQADC Interrupt and DMA Control Registers (EQADC_IDCR).
- ² Apart from generating an independent interrupt request for when a RFIFO Overflow Interrupt, a CFIFO Underflow Interrupt, and a CFIFO Trigger Overrun Interrupt occurs, the EQADC also provides a combined interrupt request at which these requests from ALL CFIFOs are ORed. Refer to Figure 27-68 for details.

Table 27-45 describes a list of methods to generate DMA requests in the EQADC.

Table 27-45. EQADC FIFO DMA Summary¹

| DMA Request | Condition | Clearing Mechanism |
|-------------------------------|---|--|
| Result FIFO Drain DMA Request | RFDE _x = 1 RFDS _x = 1 RFDF _x = 1 | The EQADC automatically clears the RFDF _x when RFIFO _x becomes empty. Writing “1” to the RFDF _x bit is not allowed. |
| Command FIFO Fill DMA Request | CFFE _x = 1 CFFS _x = 1 CFFF _x = 1 | The EQADC automatically clears the CFFF _x when CFIFO _x becomes full. Writing “1” to the CFFF _x bit is not allowed. |

NOTES:

- ¹ For details refer to [Section 27.6.2.7, EQADC FIFO and Interrupt Status Registers \(EQADC_FISR\)](#), and [Section 27.6.2.6, EQADC Interrupt and DMA Control Registers \(EQADC_IDCR\)](#).

Enhanced Queued Analog-to-Digital Converter (EQADC)

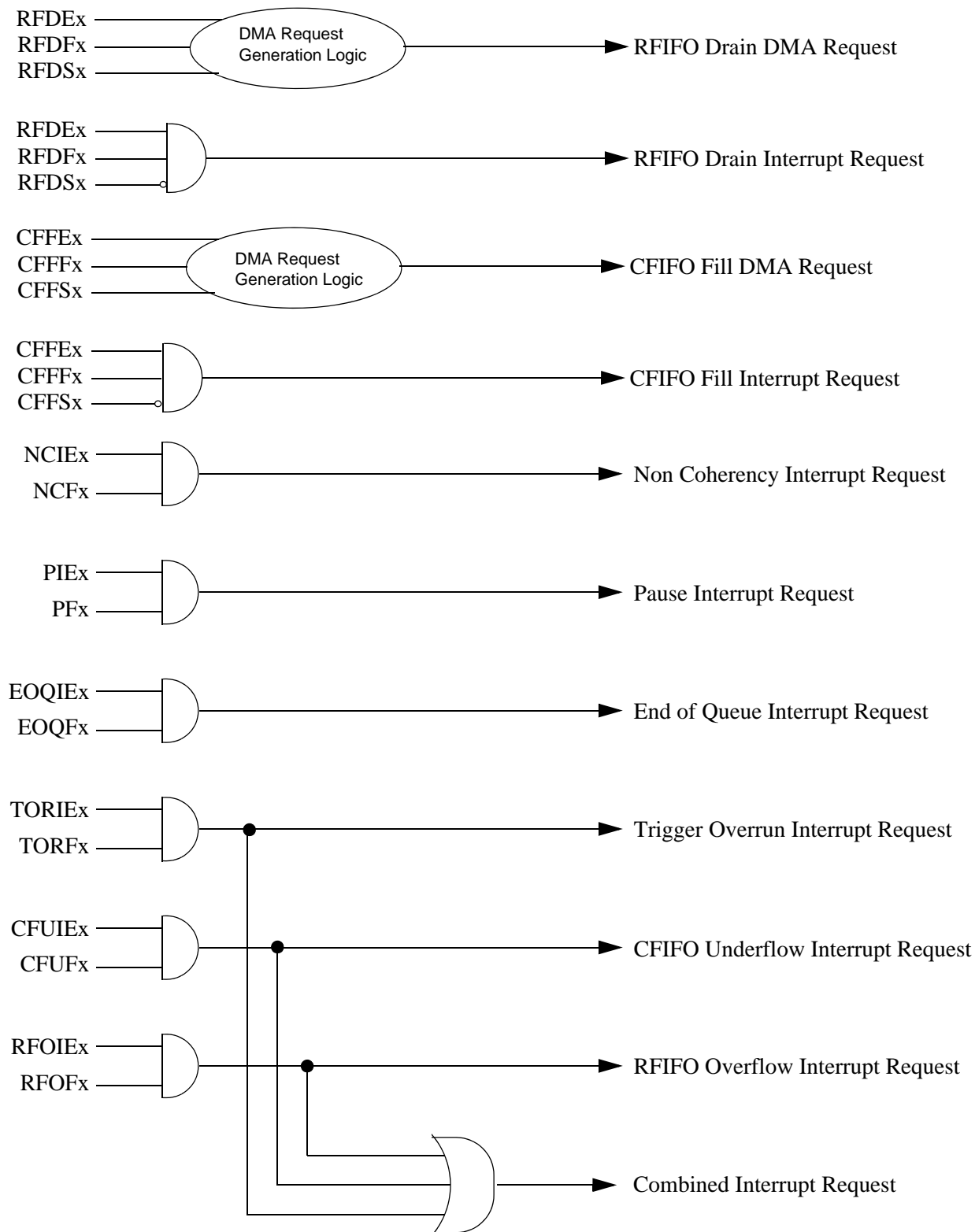

Figure 27-68. EQADC DMA and Interrupt Requests

27.7.9 Analog Sub-Block

27.7.9.1 Analog to Digital Converter (ADC)

27.7.9.1.1 ADC Architecture

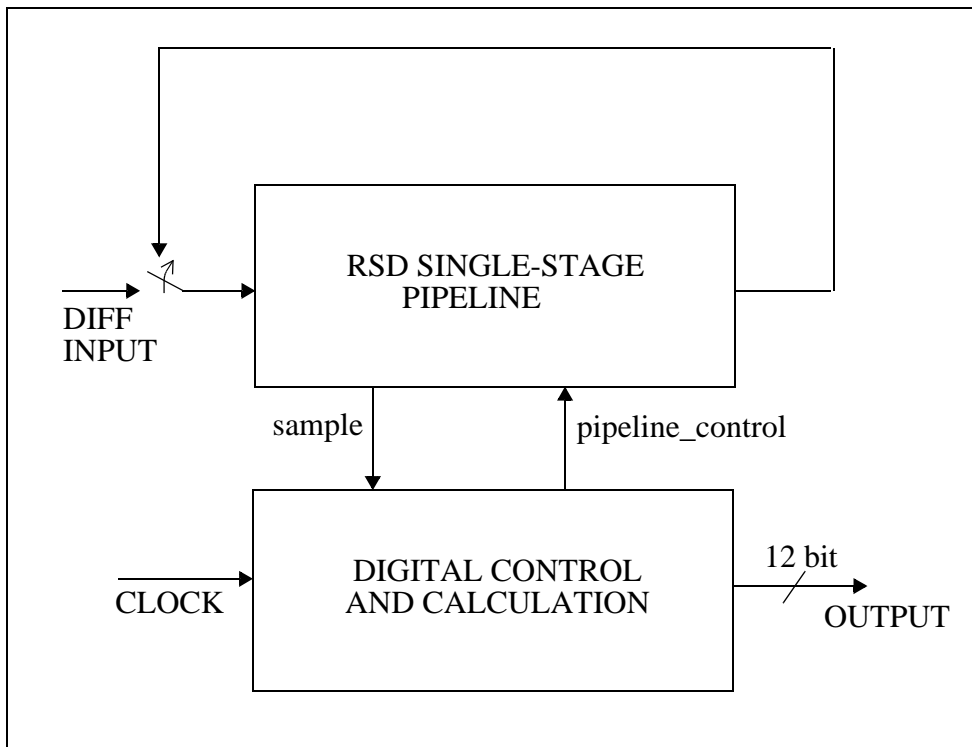

Figure 27-69. RSD ADC Block Diagram

The RSD Cyclic ADC consists of two main portions, the analog RSD Stage, and the digital control and calculation block, as shown in [Figure 27-69](#). To begin an analog to digital conversion, a differential input is passed into the analog RSD stage. The signal is passed through the RSD stage, and then from the RSD stage output, back to its input to be passed again. To complete a 12-bit conversion, the signal must pass through the RSD stage 12 times. For 10-bit and 8-bit resolution, the signal must pass 10 or 8 times through the RSD. Each time an input signal is read into the RSD stage, a digital sample is taken by the digital control/calculation block. The digital control/calculation block uses this sample to tell the analog block how to condition the signal. The digital block also saves each successive sample and adds them according to the RSD algorithm at the end of the entire conversion cycle.

27.7.9.1.2 RSD Overview

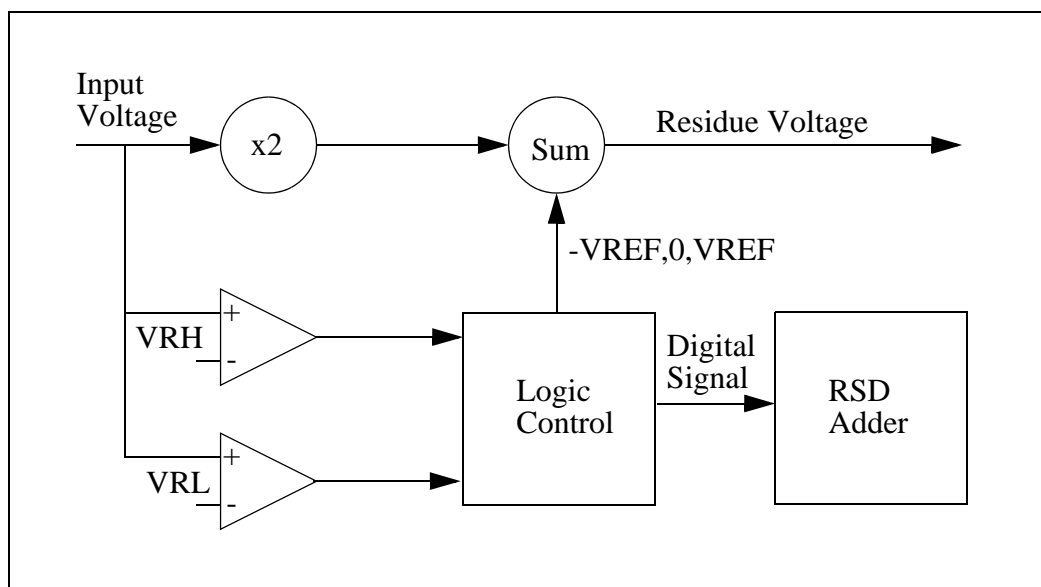

Figure 27-70. RSD Stage Block Diagram

On each pass through the RSD stage, the input signal will be multiplied by exactly two, and summed with either $-V_{REF}$, 0, or V_{REF} , depending on the Logic Control. The Logic Control will determine $-V_{REF}$, 0, or V_{REF} depending on the two comparator inputs. As the Logic Control sets the summing operation, it also sends a digital value to the RSD adder. Each time an analog signal passes through the RSD single-stage, a digital value is collected by the RSD adder. At the end of an entire AD conversion cycle, the RSD adder uses these collected values to calculate the 12-bit/10-bit/8-bit digital output.

Figure 27-71 shows the transfer function for the RSD stage. Note how the digital value (a, b) is dependent on the two comparator inputs.

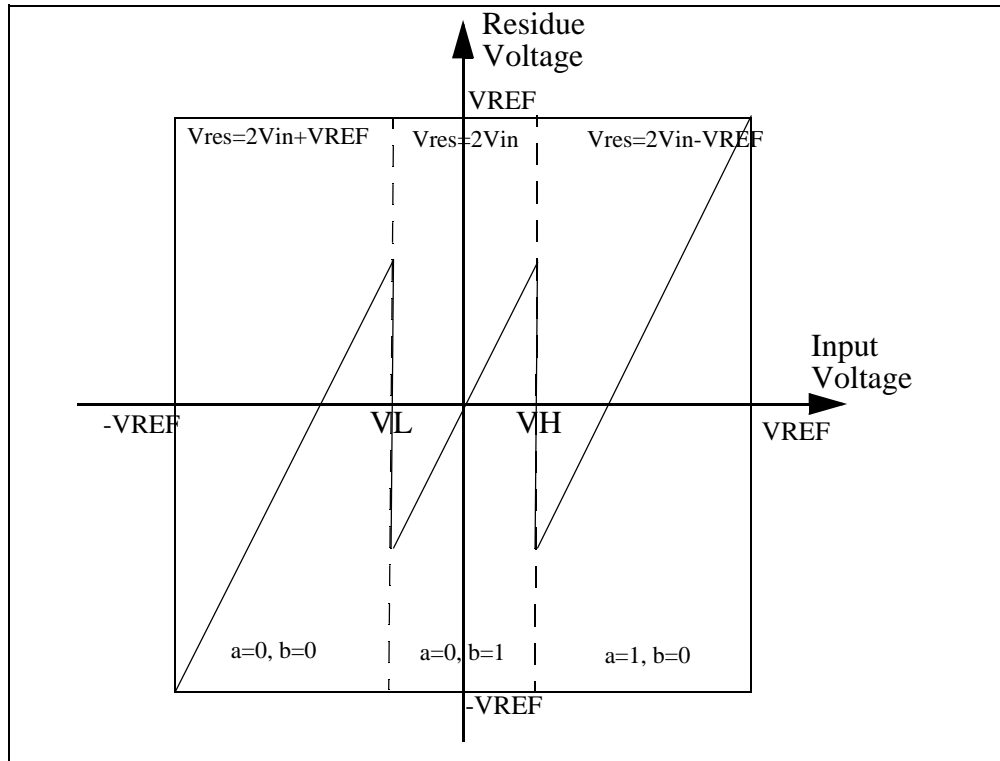

Figure 27-71. RSD Stage Transfer Function

In each pass through the RSD stage, the residue will be sent back to be the new input, and the digital signals, a and b, will be stored. For the 12-bit ADC, input signal is sampled during the input phase, and after each of the 12 passes through the RSD stage. Thus, 13 total a and b values are collected. Upon collecting all these values, they will be added according to the RSD algorithm to create the 12-bit digital representation of the original analog input. The bits are added in the following manner:

27.7.9.1.3 RSD Adder

The array, s1 to s12, will be the digital output of the RSD ADC with s1 being the MSB and s12 being the LSB.

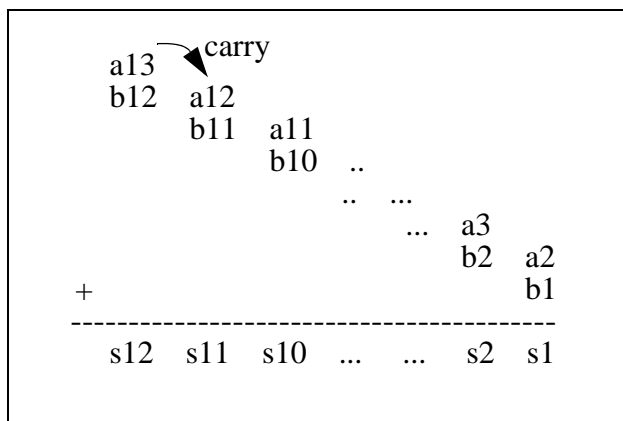

Figure 27-72. RSD Adder

27.7.9.1.4 Variable Gain Amplification (VGA) for Pre-gain

The VGA starts after sampling completes. It is enabled by a 2-bit signal PRE_GAIN described in [Section 27.6.3.6, Alternate Configuration 1-8 Control Registers \(ADC_ACR1-8\)](#).

The ADC takes 2, 8, 64 or 128 clock cycles to do sampling which is selected by the LST[0:1] field in the conversion command message. After the sampling, if 2x VGA is enabled, there is a 2x gain stage without comparison before the regular conversion cycles. When 4x VGA is enabled, there are the 2x gain stage without comparison by 2 times before the normal conversion processing.

27.8 Initialization/Application Information

27.8.1 Multiple Queues Control Setup Example

This section provides an example of how to configure multiple CQueues. [Table 27-46](#) describes how each CQueue can be used for a different application. Also documented in this section are general guidelines on how to initialize the on-chip ADCs and the external device, and how to configure the CQueues and the EQADC.

Table 27-46. Application of Each CQueue

| CQueue Number | CQueue Type | Running Speed | Number of Contiguous Conversions | Example |
|---------------|-----------------------------------|---|----------------------------------|---|
| 0 | Very fast burst time-based CQueue | every 2 μs for 200 μs; pause for 300 μs and then repeat | 2 | Injector current profiling |
| 1 | Fast hardware-triggered CQueue | every 900 μs | 3 | Current sensing of PWM controlled actuators |
| 2 | Fast repetitive time-based CQueue | every 2 ms | 8 | Throttle position |

Table 27-46. Application of Each CQueue (continued)

| CQueue Number | CQueue Type | Running Speed | Number of Contiguous Conversions | Example |
|---------------|-----------------------------------|-------------------|----------------------------------|---|
| 3 | Software-triggered CQueue | every 3.9 ms | 3 | Command triggered by software strategy |
| 4 | Repetitive angle-based CQueue | every 625 μ s | 7 | Airflow read every 30 degrees at 8000 RPM |
| 5 | Slow repetitive time-based CQueue | every 100 ms | 10 | Temperature sensors |

27.8.1.1 EQADC Initialization

The following steps provide an example about how to configure the EQADC controls and how to initialize the on-chip ADCs. In this example, all conversion commands will be transferred through CFIFO0.

1. Load all required configuration commands in the RAM in such way that they form a queue; this data structure will be referred below as CQueue0. [Figure 27-73](#) shows an example of a CQueue able to configure the on-chip ADCs at the same time. Although, this example uses the DMAC to store commands in CFIFO0, configuration commands could have also been directly written to the CFIFO0 push register.
2. Select source driving EQADC hardware trigger ports (ETRIG). Before proceeding to next step, allow some time (minimum of two platform clocks - filter period is set to minimum after reset) so that the logic level at the source is filtered and reaches the EQADC control logic.

NOTE

ETRIG ports could be driven by an external pin or by the output port of other blocks in the device, such as timers. In order to avoid unexpected triggering of CFIFOs in hardware trigger modes, the source driving the ETRIG port must be selected and set to a known logic level before putting the CFIFOs into the WAITING FOR TRIGGER state.

3. Configure [Section 27.6.2.2, EQADC External Trigger Digital Filter Register \(EQADC_ETDFR\)](#).
4. Configure the DMAC to transfer data from CQueue0 to CFIFO0 in the EQADC.
5. Configure [Section 27.6.2.6, EQADC Interrupt and DMA Control Registers \(EQADC_IDCR\)](#).
 - a. Set CFFS0 to configure the EQADC to generate a DMA request to load commands from CQueue 0 to the CFIFO0.
 - b. Set CFIE0 to enable the EQADC to generate a DMA request to transfer commands from CQueue0 to CFIFO0; Command transfers from the RAM to the CFIFO0 will start immediately.
 - c. Set EQIE0 to enable the EQADC to generate an interrupt after transferring all of the commands of CQueue0 through CFIFO0.
6. Configure [Section 27.6.2.5, EQADC CFIFO Control Registers \(EQADC_CFCR\)](#).

- a. Write 0b0001 to the MODE0 field in EQADC_CFCR0 to program CFIFO0 for software single-scan mode.
 - b. Write “1” to SSE0 to assert SSS0 and trigger CFIFO0.
7. Since CFIFO0 is in single-scan software mode and it is also the highest priority CFIFO, the EQADC starts to transfer configuration commands to the on-chip ADCs and to the external device.
 8. When all of the configuration commands have been transferred, CF0 in [Section 27.6.2.7, EQADC FIFO and Interrupt Status Registers \(EQADC_FISR\)](#), will be set. The EQADC generates a End of Queue interrupt. The initialization procedure is complete.

CQueue in
system memory

| | |
|-----|---|
| 0x0 | Configuration Command to CBuffer0 - Ex: Write ADC0_CR |
| 0x1 | Configuration Command to CBuffer0 - Ex: Write ADC_TSCR |
| 0x2 | Configuration Command to CBuffer1 - Ex: Write ADC1_CR |
| 0x3 | Configuration Command to CBuffer2 - Ex: Write to external device configuration register |

Figure 27-73. Example of a CQueue Configuring the On-Chip ADCs/External Device

The initialization procedure described above does not generate ADC clocks that are in phase because the timing at which the ADC0/1_EN bits, in the [Section 27.6.3.1, ADC0/1 Control Registers \(ADC0_CR and ADC1_CR\)](#), are set is different. Below follows an example on how to simultaneously set these bits so that in-phase ADC clocks are generated. In this example, ADC0/1_CLK are configured to the same frequency.

1. Push an ADC0_CR write configuration command in CFIFO0 that enables ADC0 (ADC0_EN=1) and that sets the ADC0_CLK_PS to an appropriate value. For example, 0x80800801.
2. Push an ADC1_CR write configuration command in CFIFO1 that enables ADC1 (ADC1_EN=1) and that sets the ADC1_CLK_PS to an appropriate value. For example, 0x82800801.
3. Configure CFIFO0 and CFIFO1 to single scan software trigger mode and simultaneously trigger them by writing 0x04100410 to the EQADC_CFCR0 register - see [Section 27.6.2.5, EQADC CFIFO Control Registers \(EQADC_CFCR\)](#).

27.8.1.2 Configuring EQADC for Applications

This section provides an example based on the applications in [Table 27-46](#). The example describes how to configure multiple CQueues to be used for those applications and provides a step-by-step procedure to configure the EQADC and the associated CQueue structures. In the example, the “Fast hardware-triggered CQueue”, described on the second row of [Table 27-46](#), will have its commands transferred to CBuffer1; the conversion commands will be executed by ADC1. The generated results will be returned to RFIFO3 before being transferred to the RQueues in the RAM by the DMAC.

NOTE

There is no fixed relationship between CFIFOs and RFIFOs with the same number. The results of commands being transferred through CFIFO1 can be returned to any RFIFO, regardless of its number. The destination of a result is determined by the MESSAGE_TAG field of the command that requested the result. See [Section 27.7.2.2, Message Format in EQADC](#), for details.

Step One: Setup the CQueues and RQueues.

1. Load the RAM with configuration and conversion commands. [Table 27-47](#) is an example of how CQueue1 commands should be set.
 - a. Each trigger event will cause four commands to be executed. When the EQADC detects the Pause bit asserted, it will wait for another trigger to restart transferring commands from the CFIFO.
 - b. At the end of the CQueue, the “EOQ” bit is asserted as shown in [Table 27-47](#).
 - c. Results will be returned to RFIFO3 as specified in the MESSAGE_TAG field of commands.
2. Reserve memory space for storing results.

Table 27-47. Example of CQueue Commands¹

| Bit # | 0 | 1 | 2 | 3 | 4 | 5 | 6 | 7 | 8 | 9 | 10 | 11 | 12 | 13 | 14 | 15 | 16 | 17 | 18 | 19 | 20 | 21 | 22 | 23 | 24 | 25 | 26 | 27 | 28 | 29 | 30 | 31 |
|----------|-----|-------|-----|----------|----|----|----------|---------------------|--|---|----|----|----|----|----|----|----|----|----|----|----|----|----|----|----|----|----|----|----|----|----|----|
| Bit Name | EOQ | PAUSE | REP | RESERVED | EB | BN | RESERVED | MESSAGE TAG | ADC COMMAND | | | | | | | | | | | | | | | | | | | | | | | |
| CMD 1 | 0 | 0 | 0 | 0 | 0 | 1 | 0 | 0b0011 | Conversion Command | | | | | | | | | | | | | | | | | | | | | | | |
| CMD 2 | 0 | 0 | 0 | 0 | 0 | 1 | 0 | 0b0011 | Conversion Command | | | | | | | | | | | | | | | | | | | | | | | |
| CMD 3 | 0 | 0 | 0 | 0 | 0 | 1 | 0 | 0b0011 | Conversion Command | | | | | | | | | | | | | | | | | | | | | | | |
| CMD 4 | 0 | 1 | 0 | 0 | 0 | 1 | 0 | 0b0011 ² | Configure peripheral device for next conversion sequence | | | | | | | | | | | | | | | | | | | | | | | |
| CMD 5 | 0 | 0 | 0 | 0 | 0 | 1 | 0 | 0b0011 | Conversion Command | | | | | | | | | | | | | | | | | | | | | | | |
| CMD 6 | 0 | 0 | 0 | 0 | 0 | 1 | 0 | 0b0011 | Conversion Command | | | | | | | | | | | | | | | | | | | | | | | |
| CMD 7 | 0 | 0 | 0 | 0 | 0 | 1 | 0 | 0b0011 | Conversion Command | | | | | | | | | | | | | | | | | | | | | | | |
| CMD 8 | 0 | 1 | 0 | 0 | 0 | 1 | 0 | 0b0011 ² | Configure peripheral device for next conversion sequence | | | | | | | | | | | | | | | | | | | | | | | |
| | | | | | | | | | etc. | | | | | | | | | | | | | | | | | | | | | | | |
| CMD EOQ | 1 | 0 | 0 | 0 | 0 | 1 | 0 | 0b0011 | EOQ Message | | | | | | | | | | | | | | | | | | | | | | | |

CFIFO Header
ADC Command

NOTES:

¹ Fields LST, TSR, FMT, and CHANNEL_NUMBER are not showed for clarity. See [Section , Conversion Command Format for the Standard Configuration](#), for details.

² MESSAGE_TAG field is only defined for read configuration commands.

Step Two: Configure the DMAC to handle data transfers between the CQueues/RQueues in RAM and the CFIFOs/RFIFOs in the EQADC.

1. For transferring, set the source address of the DMAC to point to the start address of CQueue1. Set the destination address of the DMAC to point to EQADC_CFPR1. Refer to [Section 27.6.2.3, EQADC CFIFO Push Registers \(EQADC_CFPR\)](#).
2. For receiving, set the source address of the DMAC to point to EQADC_RFPR3. Refer to [Section 27.6.2.4, EQADC Result FIFO Pop Registers \(EQADC_RFPR\)](#). Set the destination address of the DMAC to point to the starting address of RQueue1.

Step Three: Configure the EQADC Control Registers.

3. Configure [Section 27.6.2.6, EQADC Interrupt and DMA Control Registers \(EQADC_IDCR\)](#).
 - a. Set EOQIE1 to enable the End of Queue Interrupt request.
 - b. Set CFFS1 and RFDS3 to configure the EQADC to generate DMA requests to push commands into CFIFO1 and to pop result data from RFIF03.
 - c. Set CFINV1 to invalidate the contents of CFIFO1.
 - d. Set RFDE3 and CFFE1 to enable the EQADC to generate DMA requests. Command transfers from the RAM to the CFIFO1 will start immediately.
 - e. Set RFOIE3 to indicate if RFIFO3 overflows.
 - f. Set CFUIE1 to indicate if CFIFO1 underflows.
4. Configure MODE1 to continuous-scan rising edge external trigger mode in [Section 27.6.2.5, EQADC CFIFO Control Registers \(EQADC_CFCR\)](#).

Step Four: Command transfer to ADCs and Result data reception.

When an external rising edge event occurs for CFIFO1, the EQADC automatically will begin transferring commands from CFIFO1 when it becomes the highest priority CFIFO trying to send commands to CBuffer1. The received results will be placed in RFIFO3 and then moved to RQueue1 by the DMAC.

27.8.2 EQADC/DMAC Interface

This section provides an overview about the EQADC/DMAC interface and general guidelines about how the DMAC should be configured in order for it to correctly transfer data between the queues in system memory and the EQADC FIFOs.

NOTE

Advanced DMACs provide more functionality than the ones discussed in this section.

27.8.2.1 CQueue/CFIFO Transfers

In transfers involving CQueues and CFIFOs, the DMAC moves data from a queued source to a single destination as showed in [Figure 27-74](#). The location of the data to be moved is indicated by the source

address, and the final destination for that data, by the destination address. The DMAC contains a data structure containing these addresses and other parameters used in the control of data transfers. For every DMA request issued by the EQADC, the DMAC has to be configured to transfer a single command (32-bit data) from the CQueue, pointed to by the source address, to the CFIFO push register, pointed to by the destination address. After the service of a DMA request is completed, the source address has to be updated to point to the next valid command. The destination address remains unchanged. When the last command of a queue is transferred one of the following actions is recommended. Refer to the DMAC block guide for details about how this functionality is supported.

- The corresponding DMA channel should be disabled. This might be desirable for CFIFOs in single scan mode.
- The source address should be updated to point to a valid command which can be the first command in the queue that has just been transferred (cyclic queue), or the first command of any other CQueue. This is desirable for CFIFOs in continuous scan mode, and at some cases, for CFIFOs in single scan mode.

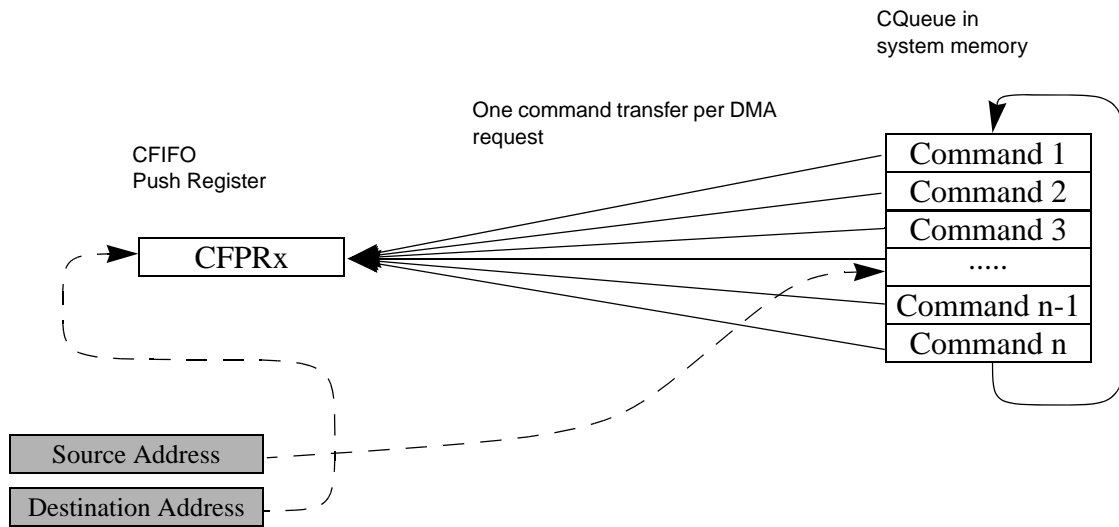

Figure 27-74. CQueue/CFIFO Interface

27.8.2.2 RQueue/RFIFO Transfers

In transfers involving RQueues and RFIFOs, the DMAC moves data from a single source to a queue destination as shown in Figure 27-75. The location of the data to be moved is indicated by the source address, and the final destination for that data, by the destination address. For every DMA request issued by the EQADC, the DMAC has to be configured to transfer a single result (16-bit data), pointed to by the source address, from the RFIFO pop register to the RQueue, pointed to by the destination address. After the service of a DMA request is completed, the destination address has to be updated to point to the location where the next 16-bit result will be stored. The source address remains unchanged. When the last expected result is written to the RQueue, one of the following actions is recommended. Refer to the DMAC block guide for details about how this functionality is supported.

- The corresponding DMA channel should be disabled.

- The destination address should be updated to point to the next location where new coming results are stored, which can be the first entry of the current RQueue (cyclic queue), or the beginning of a new RQueue.

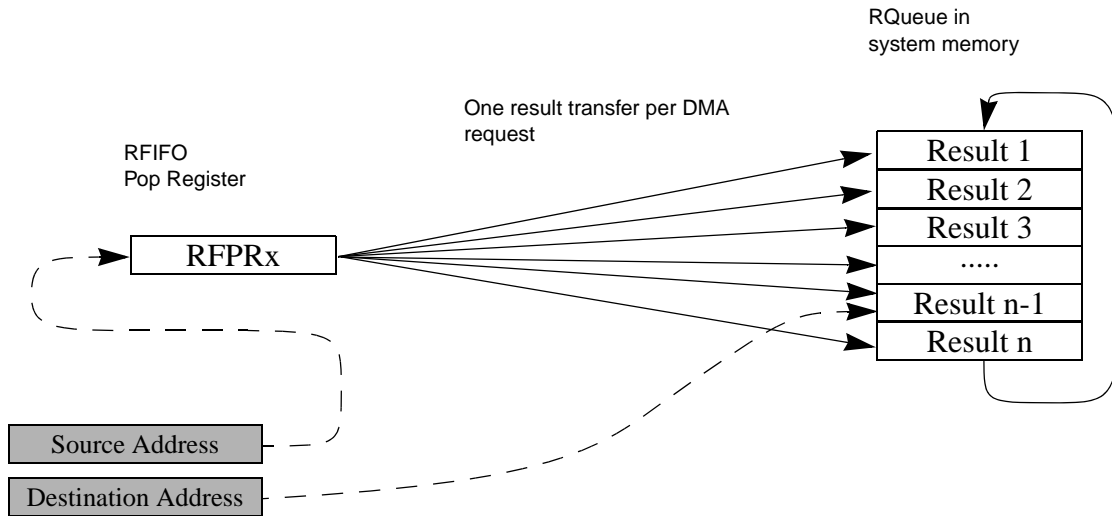

Figure 27-75. RQueue/RFIFO Interface

27.8.3 Sending Immediate Command Setup Example

In the EQADC, there is no immediate command register for sending a command immediately after writing to that register. However, a CFIFO can be configured to perform the same function as an immediate command register. The following steps illustrate how to configure CFIFO5 as an immediate command CFIFO. The results will be returned to RFIFO5.

1. Configure the [Section 27.6.2.6, EQADC Interrupt and DMA Control Registers \(EQADC_IDCR\)](#).
 - a. Clear CFIFO Fill Enable5 (CFFE5 = 0) in EQADC_IDCR2.
 - b. Clear CFIFO Underflow Interrupt Enable5 (CFUIE5 = 0) in EQADC_IDCR2.
 - c. Clear RFDS5 to configure the EQADC to generate interrupt requests to pop result data from RFIF05.
 - d. Set RFIFO Drain Enable5 (RFDE5 = 1) in EQADC_IDCR2.
2. Configure the [Section 27.6.2.5, EQADC CFIFO Control Registers \(EQADC_CFCR\)](#).
 - a. Write “1” to CFINV5 in EQADC_FCR2. This will invalidate the contents of CFIFO5.
 - b. Set MODE5 to Continuous-Scan Software Trigger mode in EQADC_CFCR2.
3. To transfer a command, write it to EQADC CFIFO Push Register 5 (EQADC_CFPR5) with Message Tag = 0b0101. Refer to [Section 27.6.2.3, EQADC CFIFO Push Registers \(EQADC_CFPR\)](#).
4. Up to four commands can be queued in CFIFO5. Check the CFCTR5 status in EQADC_FISR5 before pushing another command to avoid overflowing the CFIFO. Refer to [Section 27.6.2.7,](#)

EQADC FIFO and Interrupt Status Registers (EQADC_FISR).

5. When the EQADC receives a conversion result for RFIFO5, it generates an interrupt request. RFIFO Pop Register 5 (EQADC_RFPR5) can be popped to read the result. Refer to [Section 27.6.2.4, EQADC Result FIFO Pop Registers \(EQADC_RFPR\)](#).

27.8.4 Modifying Queues

More CQueues may be needed than the six supported by the EQADC. These additional CQueues can be supported by interrupting command transfers from a configured CFIFO, even if it is TRIGGERED and transferring, modifying the corresponding CQueue in the RAM or associating another CQueue to it, and restarting the CFIFO. More details on disabling a CFIFO are described in [Section 27.7.4.6.1, Disabled Mode](#).

1. Determine the resumption conditions when later resuming the scan of the CQueue at the point before it was modified.
 - a. Change MODEx in [Section 27.6.2.5, EQADC CFIFO Control Registers \(EQADC_CFCR\)](#), to Disabled. Refer to [Section 27.7.4.6.1, Disabled Mode](#), for a description of what happens when MODEx is changed to Disabled.
 - b. Poll CFSx until it becomes IDLE in [Section 27.6.2.10, EQADC CFIFO Status Register \(EQADC_CFSR\)](#).
 - c. Read and save TC_CFx in [Section 27.6.2.8, EQADC CFIFO Transfer Counter Registers \(EQADC_CFTCR\)](#), for later resuming the scan of the queue. The TC_CFx provides the point of resumption.
 - d. Since all result data may not have been stored in the appropriate RFIFO at the time MODEx is changed to disable, wait for all expected results to be stored in the RFIFO/RQueue before reconfiguring the DMAC to work with the modified RQueue. The number of results that must return can be estimated from the TC_CFx value obtained above.
2. Disable the DMAC from responding to the DMA request generated by CFFFx and RFDFx in [Section 27.6.2.7, EQADC FIFO and Interrupt Status Registers \(EQADC_FISR\)](#).
3. Write “0x0000” to the TC_CFx field.
4. Load the new configuration and conversion commands into RAM. Configure the DMAC to support the new CQueue/RQueue, but do not configure it yet to respond to DMA requests from CFIFOx/RFIFOx.
5. If necessary, modify [Section 27.6.2.6, EQADC Interrupt and DMA Control Registers \(EQADC_IDCR\)](#), to suit the modified CQueue.
6. Write “1” to CFINVx in [Section 27.6.2.5, EQADC CFIFO Control Registers \(EQADC_CFCR\)](#), to invalidate the entries of CFIFOx. Perform any other modifications to EQADC_CFCR except changing MODEx from Disabled.
7. Configure the DMAC to respond to DMA requests generated by CFFFx and RFDFx.
8. Change MODEx to the modified CFIFO operation mode. Write “1” to SSEx to trigger CFIFOx if MODEx is software trigger.

27.8.5 CQueue and RQueues Usage

Figure 27-76 is an example of CQueue and RQueue usage. It shows the CQueue0 commands requesting results that will be stored in RQueue0 and RQueue1, and CQueue1 commands requesting results that will be stored only in RQueue1. Some Command Messages request data to be returned from the on-chip ADC, but some only configure them and do not request returning data. When a CQueue contains both write and read commands like CQueue0, the CQueue and RQueue entries will not be aligned; as shown in Figure 27-76, the result for the second command of CQueue0 is the first entry of RQueue0. The figure also shows that CQueue and RQueue entries can also become unaligned even if all commands in a CQueue request data as CQueue1. CQueue1 entries became unaligned to RQueue1 entries because a result requested by the fourth CQueue0 command was sent to RQueue1. This happens because the system can be configured so that several CQueues can have its results sent to a single RQueue.

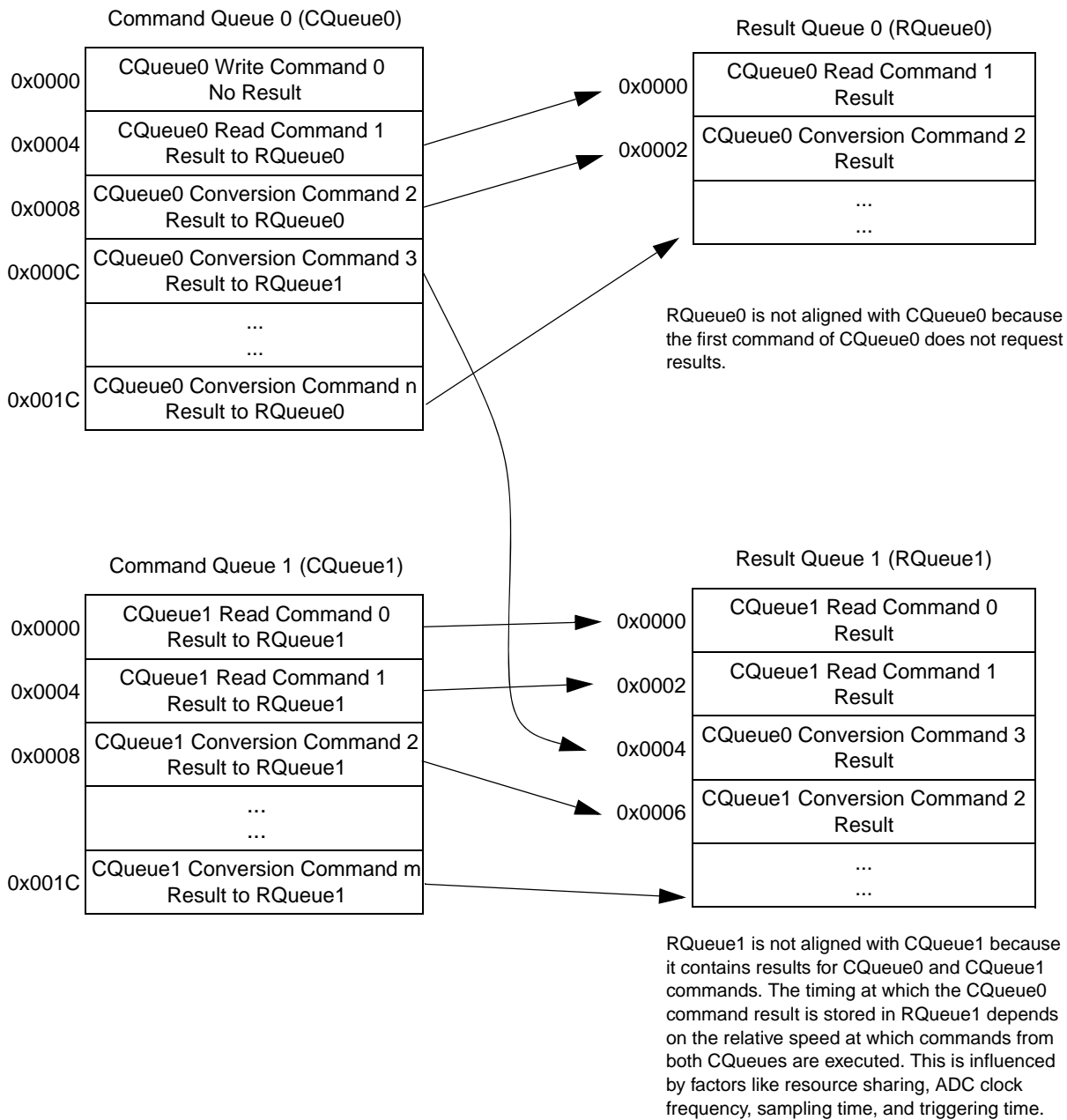

Figure 27-76. EQADC Command and Result Queues

27.8.6 ADC Result Calibration

The ADC result calibration process consists of two steps: determining the gain and offset calibration constants, and calibrating the raw results generated by the on-chip ADCs by solving the following equation discussed in [Section 27.7.6.6, ADC Calibration Feature](#).

$$\text{CAL_RES} = \text{GCC} * \text{RAW_RES} + \text{OCC}+2; \quad \text{Eqn. 27-1}$$

The calibration constants GCC and OCC can be calculated from equation [Equation 27-1](#) provided that two pairs of expected (CAL_RES) and measured (RAW_RES) result values are available for two different input voltages. Most likely calibration points to be used are 25% VREF¹ and 75% VREF since they are far apart but not too close to the end points of the full input voltage range. This allows for calculations of more representative calibration constants. The EQADC provides these voltages via channel numbers 43 and 44. The raw, uncalibrated results for these input voltages are obtained by converting these channels with conversion commands that have the CAL bit negated.

The transfer equations for when sampling these reference voltages are:

$$\text{CAL_RES}_{75\% \text{VREF}} = \text{GCC} * \text{RAW_RES}_{75\% \text{VREF}} + \text{OCC}+2;$$

$$\text{CAL_RES}_{25\% \text{VREF}} = \text{GCC} * \text{RAW_RES}_{25\% \text{VREF}} + \text{OCC}+2;$$

Thus;

$$\text{GCC} = (\text{CAL_RES}_{75\% \text{VREF}} - \text{CAL_RES}_{25\% \text{VREF}}) / (\text{RAW_RES}_{75\% \text{VREF}} - \text{RAW_RES}_{25\% \text{VREF}}); \quad \text{Eqn. 27-2}$$

$$\text{OCC} = \text{CAL_RES}_{75\% \text{VREF}} - \text{GCC} * \text{RAW_RES}_{75\% \text{VREF}} - 2; \quad \text{Eqn. 27-3}$$

or

$$\text{OCC} = \text{CAL_RES}_{25\% \text{VREF}} - \text{GCC} * \text{RAW_RES}_{25\% \text{VREF}} - 2; \quad \text{Eqn. 27-4}$$

After being calculated, the GCC and OCC values must be written to ADC registers: [Section 27.6.3.4, ADC0/1 Gain Calibration Constant Registers \(ADC0_GCCR and ADC1_GCCR\)](#), and [Section 27.6.3.5, ADC0/1 Offset Calibration Constant Registers \(ADC0_OCCR and ADC1_OCCR\)](#), using write configuration commands.

The EQADC will automatically calibrate the results, according to equation [Equation 27-1](#), of every conversion command that has its CAL bit asserted using the GCC and OCC values stored in the ADC calibration registers.

27.8.6.1 MAC Configuration Procedure

The following steps illustrate how to configure the calibration hardware, namely, determining the values of the gain and offset calibration constants, and the writing of these constants to the calibration registers. The procedure below should be performed for ADC0 and for ADC1.

1. Convert channel 44 with a command that has its CAL bit negated and obtain the raw, uncalibrated result for 25% VREF (RAW_RES_{25%VREF}).

1. VREF=VRH-VRL

2. Convert channel 43 with a command that has its CAL bit negated and obtain the raw, uncalibrated result for 75% VREF ($RAW_RES_{75\%VREF}$).
3. Since the expected values for the conversion of these voltages are known ($CAL_RES_{25\%VREF}$ and $CAL_RES_{75\%VREF}$), GCC and OCC values can be calculated from equations [Equation 27-2](#) and [Equation 27-3](#) using these values, and the ones determined in steps 1 and 2.
4. Reformat GCC and OCC to the proper data formats as specified in [Section 27.7.6.6.2, MAC Unit and Operand Data Format](#). GCC is an unsigned 15-bit fixed point value and OCC is a signed 14-bit value.
5. Write GCC value to [Section 27.6.3.4, ADC0/1 Gain Calibration Constant Registers \(ADC0_GCCR and ADC1_GCCR\)](#), and OCC value to [Section 27.6.3.5, ADC0/1 Offset Calibration Constant Registers \(ADC0_OCCR and ADC1_OCCR\)](#), using write configuration commands.

27.8.6.2 Example

The raw results obtained when sampling reference voltages 25% VREF and 75% VREF were, respectively, 3798 and 11592. The results that should have been obtained from the conversion of these reference voltages are, respectively, 4096 and 12288. Therefore, using equations [Equation 27-2](#) and [Equation 27-3](#), the gain and offset calibration constants are:

$$GCC = (12288 - 4096) / (11592 - 3798) = 1.05106492 \rightarrow 1.05102539 = 0x4388$$

$$OCC = 12288 - 1.05106492 * 11592 - 2 = 102.06 \rightarrow 102 = 0x0066$$

[Table 27-48](#) shows, for this particular case, examples of how the result values change according to GCC and OCC when result calibration is executed (CAL=1) and when it is not (CAL=0).

Table 27-48. Calibration example

| Input Voltage | Raw result (CAL=0) | | Calibrated result (CAL=1) | |
|---------------|--------------------|---------|---------------------------|-----------|
| | Hexadecimal | Decimal | Hexadecimal | Decimal |
| 25% VREF | 0x0ED6 | 3798 | 0x1000 | 4095.794 |
| 75% VREF | 0x2D48 | 11592 | 0x3000 | 12287.486 |

27.8.6.3 Quantization Error Reduction During Calibration

[Figure 27-77](#) shows how the ADC transfer curve changes due to the addition of two to the MAC output during the calibration - see MAC output equation at [Section 27.7.6.6.1, Overview](#). The maximum absolute quantization error is reduced by half leading to an increase in accuracy.

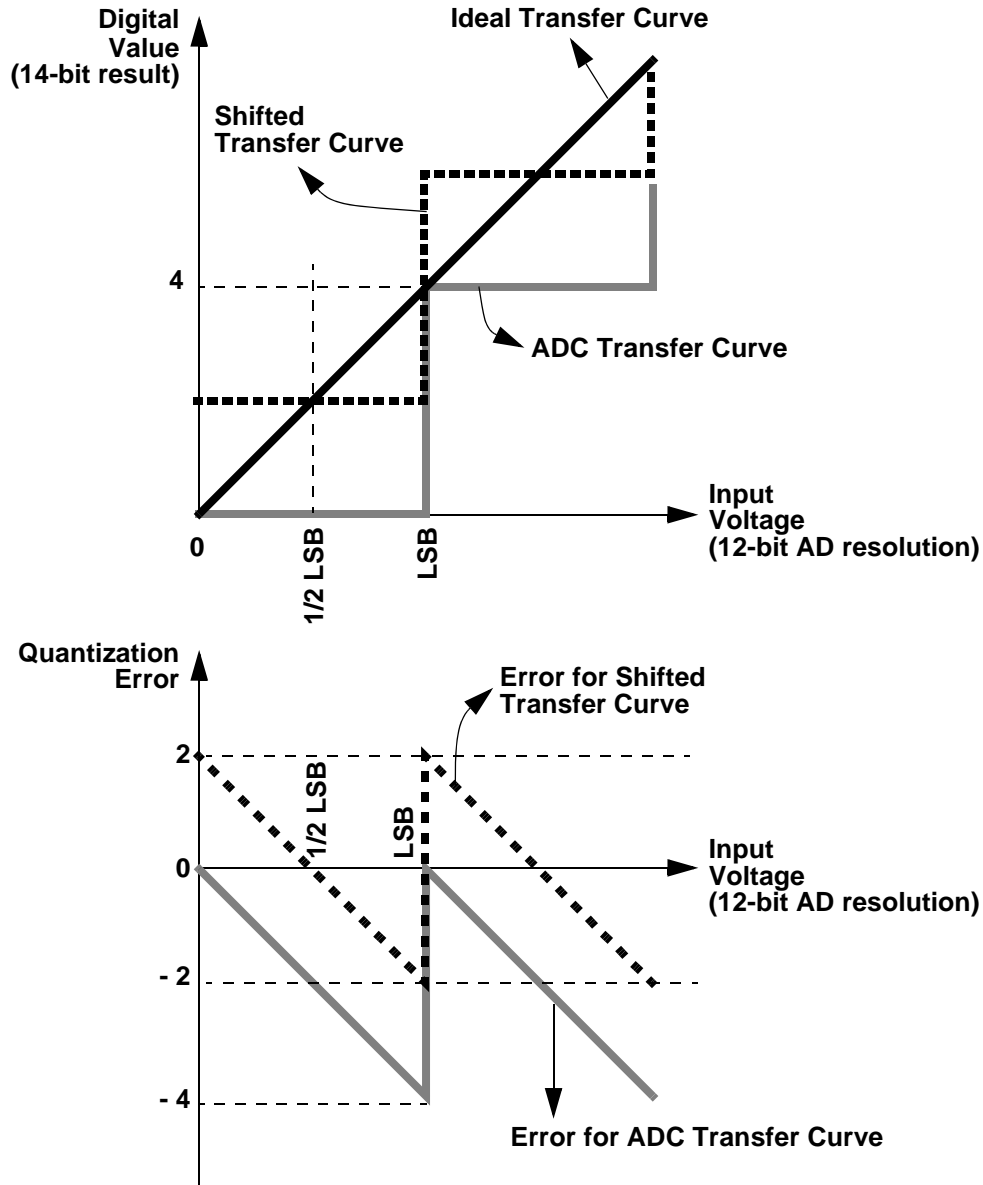

Figure 27-77. Quantization error reduction during calibration

27.8.7 EQADC Versus QADC

This section describes how the EQADC upgrades the QADC functionality. The section also provides a comparison between the EQADC and QADC in terms of their functionality. This section targets the users familiar with terminology in QADC. [Figure 27-78](#) is an overview of a QADC. [Figure 27-79](#) is an overview of the EQADC system.

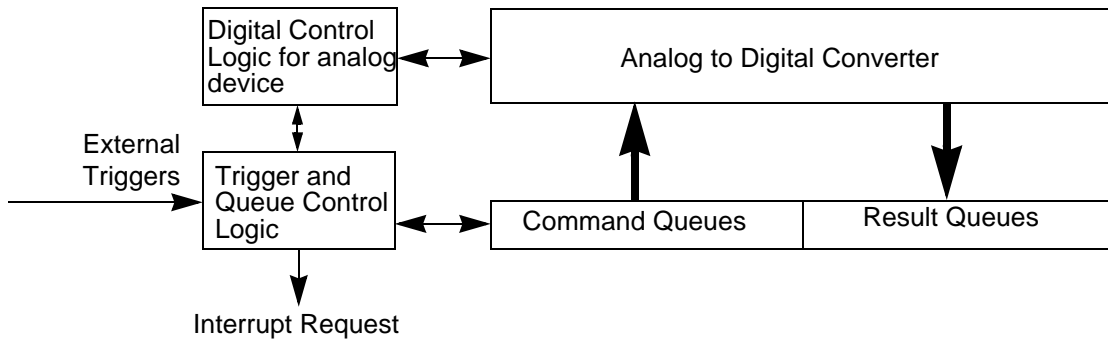

Figure 27-78. QADC Overview

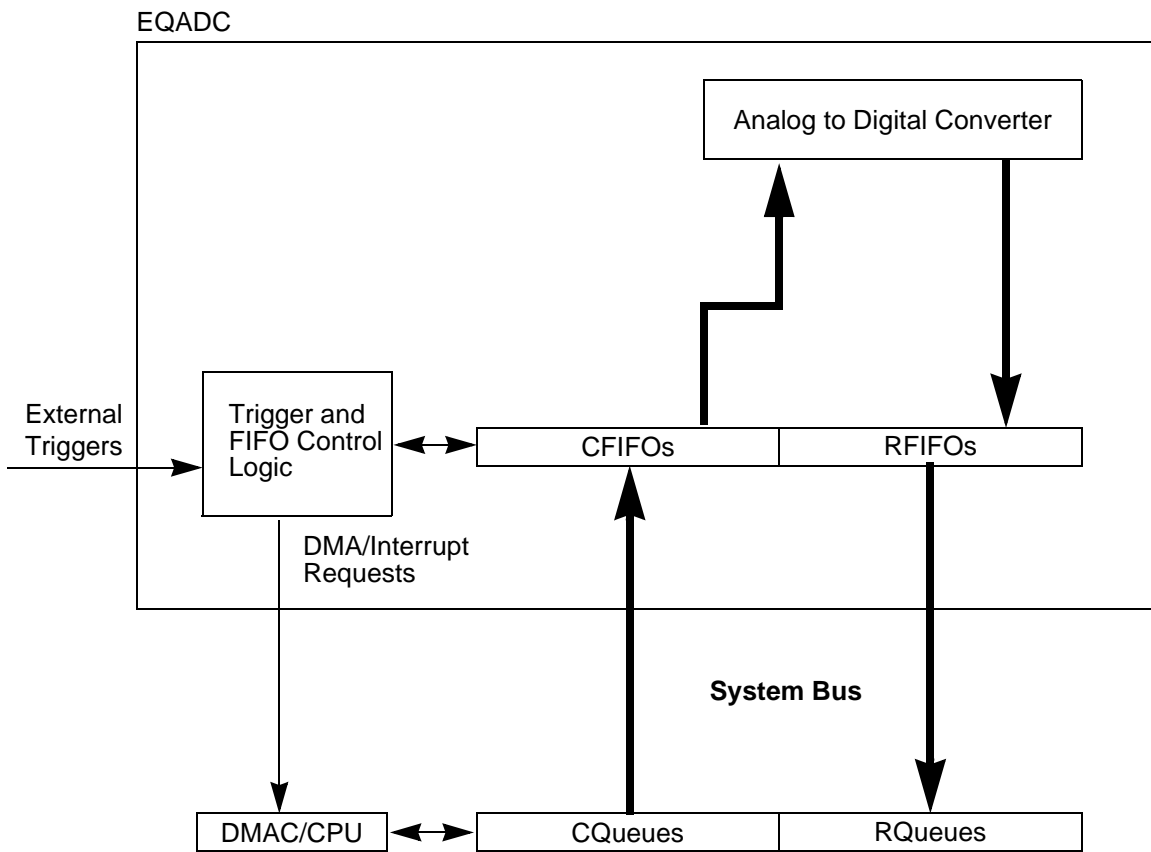

Figure 27-79. EQADC System Overview

The EQADC system consists of these parts: queues in RAM, the EQADC, and on-chip ADCs. As compared with the QADC, the EQADC system requires extra hardware.

1. A DMA or an MCU is required to move data between the EQADC's FIFOs and Queues in the system memory.

Since there are only FIFOs inside the EQADC, much of the terminology or use of the register names, register contents, and signals of the EQADC involve “FIFO” instead of “Queue”. These register names, register contents, and signals are functionally equivalent to the “Queue” counterparts in the QADC. Table 27-49 lists how the EQADC register, register contents, and signals are related to QADC.

Table 27-49. Terminology Comparison between QADC and EQADC

| QADC Terminology | EQADC Terminology | Function |
|--------------------------------------|---|---|
| CCW | Command Message | In the QADC, the hardware only executes conversion command words. In the EQADC, not all commands are conversion commands; some are configuration commands. |
| Queue Trigger | CFIFO Trigger | In the QADC, a trigger event is required to start the execution of a queue. In the EQADC, a trigger event is required to start command transfers from a CFIFO. When a CFIFO is TRIGGERED and transferring, commands are continuously moved from CQueues to CFIFOs. Thus, the trigger event initiates the “execution of a queue” indirectly. |
| Current Word Pointer Queue x (CWPQx) | Counter Value of Commands Transferred from Command FIFOx (TC_CFx) | In the QADC, CWPQx allows the last executed command on queue x to be determined. In the EQADC, the TC_CFx value allows the last transferred command on CQueue x to be determined. |
| Queue Pause Bit (P) | CFIFO Pause Bit | In the QADC, detecting a pause bit in the CCW will pause the queue execution. In the EQADC, detecting a pause bit in the Command will pause command transfers from a CFIFO. |
| Queue Operation Mode (MQx) | CFIFO Operation Mode (MODEx) | The EQADC supports all queue operation modes in the QADC except operation modes related to a periodic timer. A timer elsewhere in the system can provide the same functionality if it is connected to ETRIGx. |
| Queue Status (QS) | CFIFO Status (CFSx) | In the QADC, the Queue Status is read to check whether a queue is idle, active, paused, suspended, or trigger pending. In the EQADC, the CFIFO Status is read to check whether a queue is IDLE, WAITING FOR TRIGGER (idle or paused in QADC), or TRIGGERED (suspended or trigger pending in QADC). What CFIFO is currently “active” can be determined by reading the LCFTCBn field on the EQADC_CFSSR registers. |

The EQADC and QADC also have similar procedures for the configuration or execution of applications. Table 27-50 shows the steps required for the QADC versus the steps required for the EQADC system.

Table 27-50. Usage Comparison between QADC and EQADC System

| Procedure | QADC | EQADC System |
|------------------------------|---|---|
| Analog Control Configuration | Configure analog device by writing to the QADC registers. | Program configuration commands into command queues. |
| Prepare Scan Sequence | Program scan commands into command queues. | Program scan commands into command queues. |
| Queue Control Configuration | Write to the QADC Control Registers. | Write to the EQADC Control Registers. |

Table 27-50. Usage Comparison between QADC and EQADC System (continued)

| Procedure | QADC | EQADC System |
|---|---|--|
| Data Transferred between Queues and Buffers | Not Required. | Program the DMAC or the CPU to handle the data transfer. |
| Queue Execution | Require Software or External Trigger events to start queue execution. | Require Software or External Trigger events to start command transfers from a CFIFO. |



Chapter 28

Decimation Filter

28.1 Overview

This document describes the Decimation Filter block functionality for the PXR40 Rev 2 device, and is not valid for any other revisions of this device.

There are 12 independent Decimation Filter blocks (A through L) on the device. Each Decimation Filter block contains a multiply-accumulate (MAC) unit capable of implementing a 16-bit, 4th order IIR or 8th order FIR filter. The Decimation Filter blocks can be cascaded to create larger filters. Filter output data can be decimated at a programmable rate in the range 1 to 16.

Each Decimation Filter has a 32-bit integrator unit, which allows the block to accumulate and sum a series of filter outputs. The integrator input can be selected from before or after the decimator. The integrator can be enabled and disabled, cleared, and read by software or by hardware triggers from certain channels of the eTPU modules on the device. The integrator control triggers are selected in the SIU_DECFIL1 and SIU_DECFIL2 and SIU_DECFIL3 registers.

The data and control registers for each Decimation Filter block are independently accessed by the CPU. All Decimation Filters support DMA writes to the input data register, and DMA reads of the output data register. The eQADC_A and eQADC_B blocks have an internal hardware link to Decimation Filters A through L. This allows CPU independent transfer of eQADC_A and eQADC_B analog to digital conversion result data to the Decimation Filter input data registers, and filter output data back to the eQADC_A and eQADC_B conversion result FIFOs.

Each Decimation Filter block supports 4 combinations of input data source and output result destination:

1. **Input from eQADC/Output to eQADC:** In this mode, the Decimation Filter receives analog to digital conversion data samples from the eQADC block. The output result from the Decimation Filter is automatically returned to the RFIFO in eQADC that was specified in the conversion command for the ADC input.
2. **Input from system RAM/Output to system RAM:** In this mode, the input data to the Decimation filter is supplied from system RAM by the CPU or DMA. The filter data and associated commands are written to a memory mapped input register, and the output results are written to a memory mapped register, where they can be read by either CPU or DMA.
3. **Input from eQADC/Output to system RAM:** In this mode, the Decimation Filters can be configured for input data from eQADC and output result to the system RAM (CPU or DMA).
4. **Input from system RAM/Output to eQADC:** In this mode, the Decimation Filter input data from system RAM (CPU or DMA), and the output result is sent to an eQADC result FIFO.

Each Decimation Filter block can be programmed to generate interrupt requests when input data is received from the eQADC, when the filter result is written to the output buffer, if a filter overflow occurs,

Decimation Filter

and if either input or output buffer overruns occur. An interrupt can also be generated when an integrator result is ready to be read.

Figure 28-1 shows a system-level block diagram of a single Decimation Filter. All Decimation Filters share the same configuration, with some differences in the hardware trigger sources for the integrator controls.

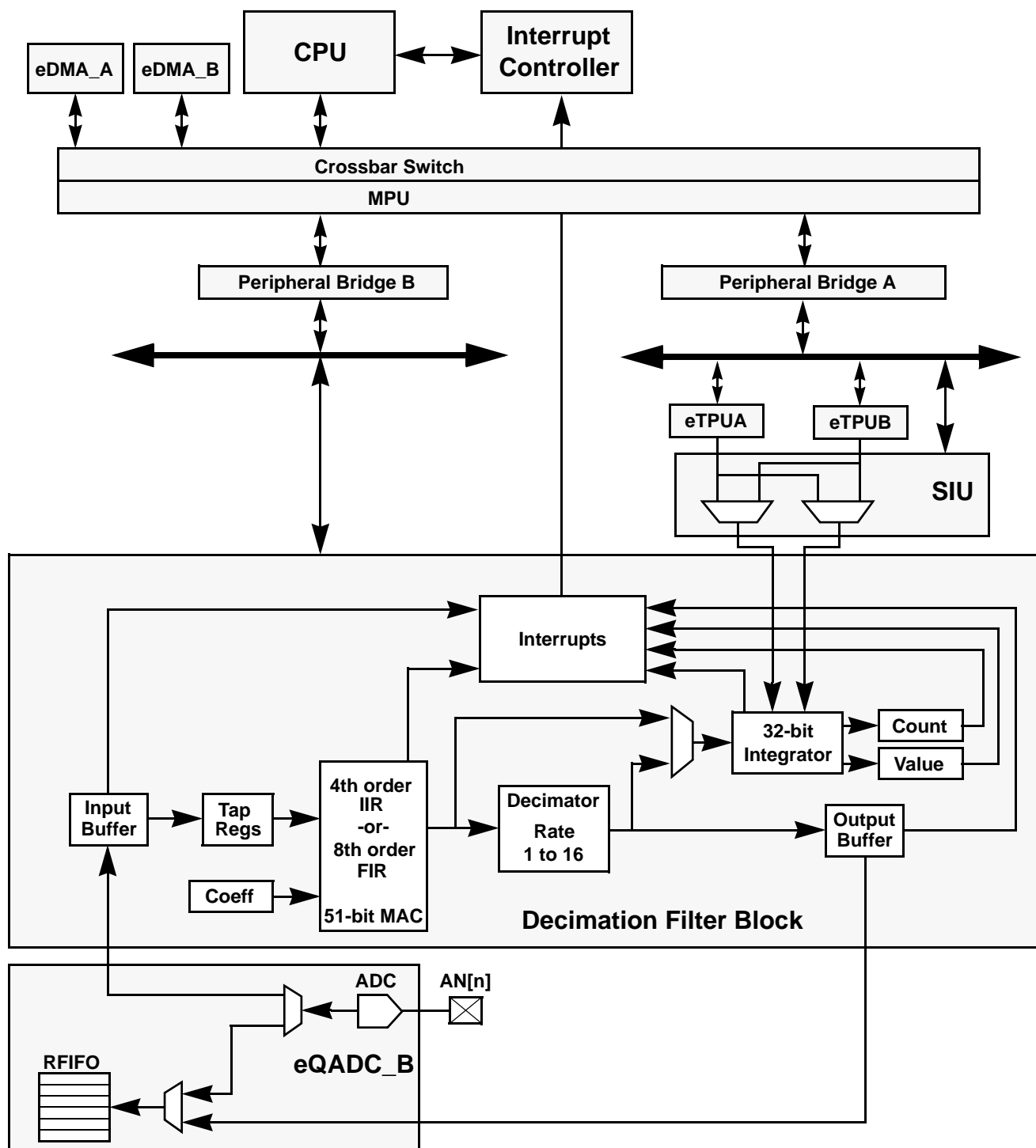

Figure 28-1. Decimation Filter Block Diagram

28.1.1 Features

The decimation filter block includes these features:

- Selectable 4th order IIR filter, or 8th order FIR filter
 - 16-bit, two’s complement signed input/output data
 - Internal taps with 16-bit (feed-forward taps) and 24-bit (feedback taps) resolutions (fixed point) for two’s complement signed value
 - 24-bit programmable filter coefficients (fixed point) for two’s complement signed value
 - MAC unit with 51-bit fixed point accumulator
 - Convergent rounding methodology
 - Two’s complement overflow or saturation selection
 - 58 system (core frequency divided by two) clock cycles to process the input
- Direct data input from the on-chip eQADC_A and eQADC_B block
- DMA access to input and output data buffers
- CPU accessible status/configuration registers and data input/output
- Filter initialization (flush) and stabilization (prefill) commands
- Timestamp support
- Programmable integer decimation rates of 1 to 16
- 32-bit, fixed point, signed or unsigned integrator unit with hardware triggered windowing
- Cascading of two or more blocks to create more complex filters

28.1.2 Modes of Operation Overview

This section provides an overview of the operational modes of the Decimation Filter. The modes are selected using the Module Configuration Register fields MDIS, FREN, and FRZ (see [Section 28.2.2.1, Decimation Filter Module Configuration Register \(DECFLT_x_MCR\)](#)). The mode selection is summarized in [Table 28-1](#).

Table 28-1. Operation Mode Selection

| Mode | MDIS | FREN, FRZ |
|----------|------|-----------------------|
| Normal | 0 | (0,0), (0,1) or (1,0) |
| Freeze | 0 | 1, 1 |
| Disabled | 1 | X |

28.1.2.1 Normal Mode

This is the default operational mode of the Decimation Filter. In this mode, the Decimation Filter processes each new input in the input buffer according the filter, decimator, and integrator configuration.

28.1.2.2 Freeze Mode

This mode is also known as debug mode. All filter action is frozen. If the filter is processing an input, it enters freeze mode only after the current processing finishes. More details of freeze mode may be found in [Section 28.3.8, Freeze Mode](#).

28.1.2.3 Disabled Mode

Each Decimation Filter block may be disabled by setting the `DECFLT_x_MCR[MDIS]` bit in the respective block instance.

28.2 Memory Map and Register Definition

This section provides the memory maps and detailed descriptions of all registers. There are eight Decimation Filter blocks on the device. Each Decimation Filter block has its own independent set of registers as defined in [Section 28.2.2, Decimation Filter Register Descriptions](#). The base address of each Decimation Filter block is given in [Table 28-2](#).

Table 28-2. Decimation Filter Modules Base Address

| Module | Address |
|---------------|-------------|
| DECFLT_A_BASE | 0xFFF8_8000 |
| DECFLT_B_BASE | 0xFFF8_8800 |
| DECFLT_C_BASE | 0xFFF8_9000 |
| DECFLT_D_BASE | 0xFFF8_9800 |
| DECFLT_E_BASE | 0xFFF8_A000 |
| DECFLT_F_BASE | 0xFFF8_A800 |
| DECFLT_G_BASE | 0xFFF8_B000 |
| DECFLT_H_BASE | 0xFFF8_B800 |

28.2.1 Decimation Filter Memory Map

The addresses of the Decimation Filter registers are specified as offsets from the module's base address as described in [Table 28-3](#).

Table 28-3. Block Memory Map

| Address | Register | Bits | Access | Reset Value | Section/Page |
|-----------------------|---|------|--------|-------------|--------------------------------|
| DECFLT_x_BASE + 0x000 | DECFILTER_MCR — Module Configuration Register | 32 | R/W | 0x0000_0000 | 28.2.2.1/28-7 |
| DECFLT_x_BASE + 0x004 | DECFILTER_MSR — Module Status Register | 32 | R/W | 0x0000_0000 | 28.2.2.2/28-11 |
| DECFLT_x_BASE + 0x008 | DECFILTER_MXCR — Module Extended Configuration Register | 32 | R/W | 0x0000_0000 | 28.2.2.3/28-13 |

Table 28-3. Block Memory Map (continued)

| Address | Register | Bits | Access | Reset Value | Section/Page |
|-----------------------------|---|------|--------|-------------|--------------------------------|
| DECFLT_x_BASE + 0x00C | DECFILTER_MXSR — Module Extended Status Register | 32 | R/W | 0x0000_0000 | 28.2.2.4/28-16 |
| DECFLT_x_BASE + 0x010 | DECFILTER_IB — Interface Input Buffer | 32 | R/W | 0x0000_0000 | 28.2.2.5/28-19 |
| DECFLT_x_BASE + 0x014 | DECFILTER_OB — Interface Output Buffer | 32 | R | 0x0000_0000 | 28.2.2.6/28-20 |
| DECFLT_x_BASE + 0x018–0x01F | Reserved | | | | |
| DECFLT_x_BASE + 0x020 | DECFILTER_COEF0 — Filter Coefficient 0 | 32 | R/W | 0x0000_0000 | 28.2.2.7/28-20 |
| DECFLT_x_BASE + 0x024 | DECFILTER_COEF1 — Filter Coefficient 1 | 32 | R/W | 0x0000_0000 | 28.2.2.7/28-20 |
| DECFLT_x_BASE + 0x028 | DECFILTER_COEF2 — Filter Coefficient 2 | 32 | R/W | 0x0000_0000 | 28.2.2.7/28-20 |
| DECFLT_x_BASE + 0x02C | DECFILTER_COEF3 — Filter Coefficient 3 | 32 | R/W | 0x0000_0000 | 28.2.2.7/28-20 |
| DECFLT_x_BASE + 0x030 | DECFILTER_COEF4 — Filter Coefficient 4 | 32 | R/W | 0x0000_0000 | 28.2.2.7/28-20 |
| DECFLT_x_BASE + 0x034 | DECFILTER_COEF5 — Filter Coefficient 5 | 32 | R/W | 0x0000_0000 | 28.2.2.7/28-20 |
| DECFLT_x_BASE + 0x038 | DECFILTER_COEF6 — Filter Coefficient 6 | 32 | R/W | 0x0000_0000 | 28.2.2.7/28-20 |
| DECFLT_x_BASE + 0x03C | DECFILTER_COEF7 — Filter Coefficient 7 | 32 | R/W | 0x0000_0000 | 28.2.2.7/28-20 |
| DECFLT_x_BASE + 0x040 | DECFILTER_COEF8 — Filter Coefficient 8 | 32 | R/W | 0x0000_0000 | 28.2.2.7/28-20 |
| DECFLT_x_BASE + 0x044–0x077 | Reserved | | | | |
| DECFLT_x_BASE + 0x078 | DECFILTER_TAP0 — Filter TAP ¹ 0 Register | 32 | R | 0x0000_0000 | 28.2.2.8/28-21 |
| DECFLT_x_BASE + 0x07C | DECFILTER_TAP1 — Filter TAP 1 Register | 32 | R | 0x0000_0000 | 28.2.2.8/28-21 |
| DECFLT_x_BASE + 0x080 | DECFILTER_TAP2 — Filter TAP 2 Register | 32 | R | 0x0000_0000 | 28.2.2.8/28-21 |
| DECFLT_x_BASE + 0x084 | DECFILTER_TAP3 — Filter TAP 3 Register | 32 | R | 0x0000_0000 | 28.2.2.8/28-21 |
| DECFLT_x_BASE + 0x088 | DECFILTER_TAP4 — Filter TAP 4 Register | 32 | R | 0x0000_0000 | 28.2.2.8/28-21 |
| DECFLT_x_BASE + 0x08C | DECFILTER_TAP5 — Filter TAP 5 Register | 32 | R | 0x0000_0000 | 28.2.2.8/28-21 |

Table 28-3. Block Memory Map (continued)

| Address | Register | Bits | Access | Reset Value | Section/Page |
|-----------------------------|--|------|--------|-------------|---------------------------------|
| DECFLT_x_BASE + 0x090 | DECFILTER_TAP6 — Filter TAP 6 Register | 32 | R | 0x0000_0000 | 28.2.2.8/28-21 |
| DECFLT_x_BASE + 0x094 | DECFILTER_TAP7 — Filter TAP 7 Register | 32 | R | 0x0000_0000 | 28.2.2.8/28-21 |
| DECFLT_x_BASE + 0x098–0x0CF | Reserved | | | | |
| DECFLT_x_BASE + 0x0D0 | DECFILTER_EDID — Enhanced Debug Input Data | 32 | R | 0x0000_0000 | 28.2.2.9/28-22 |
| DECFLT_x_BASE + 0x0D4–0x0DF | Reserved | | | | |
| DECFLT_x_BASE + 0x0E0 | DECFILTER_FINTVAL — Final Integration Value Register | 32 | R | 0x0000_0000 | 28.2.2.10/28-23 |
| DECFLT_x_BASE + 0x0E4 | DECFILTER_FINTCNT — Final Integration Count Register | 32 | R | 0x0000_0000 | 28.2.2.11/28-23 |
| DECFLT_x_BASE + 0x0E8 | DECFILTER_CINTVAL — Current Integration Value Register | 32 | R | 0x0000_0000 | 28.2.2.12/28-24 |
| DECFLT_x_BASE + 0x0EC | DECFILTER_CINTCNT — Current Integration Count Register | 32 | R | 0x0000_0000 | 28.2.2.13/28-24 |
| DECFLT_x_BASE + 0x0F0–0x1FF | Reserved | | | | |

¹ The TAP register stores, on each filter node, the input sample data and, for the IIR type, the filter intermediary results.

28.2.2 Decimation Filter Register Descriptions

All registers are 32-bit wide, and each of the eight Decimation Filters on the device have the same register interface.

28.2.2.1 Decimation Filter Module Configuration Register (DECFLT_x_MCR)

The Decimation Filter module configuration register provides configuration control bits for the Decimation Filter internal logic.

NOTE

Do not modify this register's contents when the status bit BSY is set, except for fields FREN, FRZ and IDIS. To guarantee that BSY does not set during the read-modify-write operation, it is advisable to set IDIS=1 and wait for BSY=0 beforehand.

Decimation Filter

Address: DECFILT_x_BASE + 0x000

Access: User read/write

| | | | | | | | | | | | | | | | | |
|-------|------|------|-------------|-----|---------------|------------|----|------|------|-------|------|------------|------|-----------|-------|----|
| | 0 | 1 | 2 | 3 | 4 | 5 | 6 | 7 | 8 | 9 | 10 | 11 | 12 | 13 | 14 | 15 |
| R | MDIS | FREN | 0 | FRZ | 0 | CASCD[1:0] | | IDEN | ODEN | ERREN | 0 | FTYPE[1:0] | 0 | SCAL[1:0] | | |
| W | | | | | SRES | | | | | | | | | | | |
| Reset | 0 | 0 | 0 | 0 | 0 | 0 | 0 | 0 | 0 | 0 | 0 | 0 | 0 | 0 | 0 | 0 |
| | 16 | 17 | 18 | 19 | 20 | 21 | 22 | 23 | 24 | 25 | 26 | 27 | 28 | 29 | 30 | 31 |
| R | IDIS | SAT | IO_SEL[1:0] | | DEC_RATE[3:0] | | | | SDIE | DSEL | IBIE | OBIE | EDME | TORE | TMODE | |
| W | | | | | | | | | | | | | | | | |
| Reset | 1 | 0 | 0 | 0 | 0 | 0 | 0 | 0 | 0 | 0 | 0 | 0 | 0 | 0 | 0 | 0 |

Figure 28-2. Decimation Filter Module Configuration Register (DECFILT_x_MCR)

Table 28-4. DECFILT_x_MCR Field Descriptions

| Field | Description |
|--------------|--|
| 0 MDIS | Module Disable—Puts the Decimation Filter in low power mode. Communication through the eQADC Interface is ignored in this mode. Writes to the configuration register are allowed with the exception of writes to the FREN and SRES bits, which are ignored. Writes to the Coefficient registers are allowed. The Decimation Filter cannot enter Freeze mode once in disable mode. 0 Normal Mode 1 Low Power Mode |
| 1 FREN | Freeze Enable—Enables the Decimation Filter to enter freeze mode See Section 28.3.8, Freeze Mode , for more details. 0 Freeze mode disabled 1 Freeze mode enabled |
| 2 | Reserved |
| 3 FRZ | Freeze Mode—Controls the freeze mode of the Decimation Filter. For this bit to take effect the FREN freeze enable bit also needs to be asserted. While in freeze mode the MAC operations are halted. See Section 28.3.8, Freeze Mode , for more details. 0 Normal Mode 1 Freeze Mode |
| 4 SRES | Software-reset bit—A self-negated bit which provides the capability to initialize the Decimation Filter interface. This bit always reads as zero. See Section 28.3.7, Soft Reset Command , for more details. 0 No action 1 Software-Reset |
| 5–6 CASCD | Cascade Mode Configuration—Configures the block to work in cascade mode of operation. For more details about the cascade mode, see Section 28.3.14, Cascade Mode . 00 No cascade mode (single block) 01 Cascade Mode, Head block config 10 Cascade Mode, Tail block config 11 Cascade Mode, Middle block config Note: Any change to this field must follow the procedure described in the Section 28.3.14.2, Cascade Freeze, Stop, and Configuration Change Procedures . |
| 7 IDEN | Input Data Interrupt Enable—Enables the Decimation Filter to generate interrupt requests on all new input data written to the Interface Input Buffer register. 0 Input Data Interrupt Disabled 1 Input Data Interrupt Enabled |

Table 28-4. DECFILT_x_MCR Field Descriptions (continued)

| Field | Description | | | | | | | | | | | | | | | | | | | | |
|-----------------|--|---------------------------------|----------------------------------|-------------------|---------------------------|---|---|-----------------------------|-------------|---|---|-----------------------------|----------------------------------|---|---|---------------------------------|----------------------------------|---|---|---------------------------------|-------------|
| 8 ODEN | Output Data Interrupt Enable—Enables the Decimation Filter to generate interrupt requests on all new data written to the filter Output buffer. This is independent of the IO_SEL field setting. 0 Output Data Interrupt Disabled 1 Output Data Interrupt Enabled | | | | | | | | | | | | | | | | | | | | |
| 9 ERREN | Error Interrupt Enable—Enables the Decimation Filter to generate interrupt requests based on the assertion of the DECFILTER_MSR register error flags OVF, DIVR, SVR, OVR or IVR. 0 Error Interrupts Disabled 1 Error Interrupts Enabled | | | | | | | | | | | | | | | | | | | | |
| 10 | Reserved | | | | | | | | | | | | | | | | | | | | |
| 11–12 FTYPE | Filter Type Selection bits—Selects the filter type. 00 Filter Bypass 01 IIR Filter - 1 x 4th order 10 FIR Filter - 1 x 8th order 11 Reserved | | | | | | | | | | | | | | | | | | | | |
| 13 | Reserved | | | | | | | | | | | | | | | | | | | | |
| 14–15 SCAL | Filter Scaling Factor—Selects the scaling factor used by the filter algorithm. 00 Scaling Factor = 1 01 Scaling Factor = 4 10 Scaling Factor = 8 11 Scaling Factor = 16 | | | | | | | | | | | | | | | | | | | | |
| 16 IDIS | Input Disable—Disables the block input, so that writes to the input buffer have no effect and input DMA or interrupt requests are not issued. Input disabling is needed to change the block configuration to or from cascade mode. 0 Input enabled 1 Input disabled | | | | | | | | | | | | | | | | | | | | |
| 17 SAT | Saturation Enable—Enables the saturation of the filter output. See Section 28.3.11, Saturation , for more details. 0 Disables Saturation 1 Enable Saturation | | | | | | | | | | | | | | | | | | | | |
| 18–19 IO_SEL | Input Data Source and Output Result Destination Selection—Selects the source of the input data to the Decimation Filter, and the destination for the filter output result. The IO_SEL[1:0] encoding and associated source and destination definitions is given below. Note that when Decimation Filters are cascaded to form larger filters, the IO_SEL[1:0] field only is applicable to the input data source for the head filter in the cascade, and to the output result destination for the tail filter in the cascade. Filters in the middle of the cascade receive input and send output to their adjacent filters in the cascade. Regardless of the IO_SEL setting, the Decimation Filter input and output buffer registers can be read by the CPU/DMA at any time, and the output buffer register is updated in the case of the eQADC result destination. Note that the eQADC module has to be configured to send conversion results to a decimation filter in addition to setting the IO_SEL field. <table border="1" style="margin-left: auto; margin-right: auto;"> <thead> <tr> <th>IO_SEL[1]</th> <th>IO_SEL[0]</th> <th>Input Data Source</th> <th>Output Result Destination</th> </tr> </thead> <tbody> <tr> <td>0</td> <td>0</td> <td>eQADC A/D conversion result</td> <td>eQADC RFIFO</td> </tr> <tr> <td>0</td> <td>1</td> <td>eQADC A/D conversion result</td> <td>Output Buffer Register (CPU/DMA)</td> </tr> <tr> <td>1</td> <td>0</td> <td>Input Buffer Register (CPU/DMA)</td> <td>Output Buffer Register (CPU/DMA)</td> </tr> <tr> <td>1</td> <td>1</td> <td>Input Buffer Register (CPU/DMA)</td> <td>eQADC RFIFO</td> </tr> </tbody> </table> | IO_SEL[1] | IO_SEL[0] | Input Data Source | Output Result Destination | 0 | 0 | eQADC A/D conversion result | eQADC RFIFO | 0 | 1 | eQADC A/D conversion result | Output Buffer Register (CPU/DMA) | 1 | 0 | Input Buffer Register (CPU/DMA) | Output Buffer Register (CPU/DMA) | 1 | 1 | Input Buffer Register (CPU/DMA) | eQADC RFIFO |
| IO_SEL[1] | IO_SEL[0] | Input Data Source | Output Result Destination | | | | | | | | | | | | | | | | | | |
| 0 | 0 | eQADC A/D conversion result | eQADC RFIFO | | | | | | | | | | | | | | | | | | |
| 0 | 1 | eQADC A/D conversion result | Output Buffer Register (CPU/DMA) | | | | | | | | | | | | | | | | | | |
| 1 | 0 | Input Buffer Register (CPU/DMA) | Output Buffer Register (CPU/DMA) | | | | | | | | | | | | | | | | | | |
| 1 | 1 | Input Buffer Register (CPU/DMA) | eQADC RFIFO | | | | | | | | | | | | | | | | | | |

Table 28-4. DECFILT_x_MCR Field Descriptions (continued)

| Field | Description |
|-------------------|---|
| 20–23 DEC_RATE | Decimation Rate Selection—Selects the decimation rate used by the Decimation Filter. The decimation rate defines the number of data samples from the master block that is required to generate one decimated result in the Decimation Filter output. 0000 No Decimation: one filter output for each sample input 0001–1111 One filter output for each (DEC_RATE+1) sample inputs |
| 24 SDIE | Integrator Data Interrupt Enable—Enables output buffer interrupts due to integrator data result being ready. 0 Integration ready does not cause an output interrupt. 1 Integration ready causes an output interrupt |
| 25 DSEL | DMA Selection—Determines whether the data transfers — to the input buffer (write to) and from the output buffer (read from) — are performed by DMA requests or by interrupt requests. 0 Interrupt requests are generated 1 DMA requests are generated |
| 26 IBIE | Input Buffer Interrupt Request Enable—Enables the Decimation Filter to generate interrupt requests when: <ul style="list-style-type: none"> • CPU/DMA is selected (IO_SEL[1]=1), DSEL=0, and the input buffer is available to receive new data; • eQADC input is selected with Enhanced debug (IO_SEL[1]=0, EDME=1), DSEL=0, and the input buffer has data to be read by the CPU. 0 Input Buffer Interrupt Request Disabled 1 Input Buffer Interrupt Request Enabled |
| 27 OBIE | Output Buffer Interrupt Request Enable—Enables the Decimation Filter interrupt requests when outputs are directed to the CPU/DMA and DMA requests is not selected (DSEL=0). 0 Output Buffer Interrupt Request Disabled 1 Output Buffer Interrupt Request Enabled |
| 29 EDME | Enhanced Debug Monitor Enable—Defines the enhanced debug monitor when input selection is from eQADC (IO_SEL[1]=0). 0 Enhanced debug monitor disabled 1 Enhanced debug monitor enabled |
| 29 TORE | Triggered Output Result Enable—Enables an eTPU signal to transfer the filter result to its destination, using the mode specified by TMODE[1:0]. 0 Output buffer transfer by eTPU signal disabled 1 Output buffer transfer by eTPU signal enabled |
| 30–31 TMODE | Trigger Mode—Selects the way the eTPU signal controls the transfer of a new output result 00 result is transferred at the rising edge of the eTPU signal 01 result is transferred while the eTPU signal is 0 10 result is transferred at the falling edge of the eTPU signal 11 result is transferred while the eTPU signal is 1 |

28.2.2.2 Decimation Filter Module Status Register (DECFLT_x_MSR)

Address: DECFLT_x_BASE + 0x004

Access: User read/write

| | | | | | | | | | | | | | | | | |
|-------|-----|----|------------------|----|----|------|------|-----|----|------|------|----|-------|------|-----|------|
| | 0 | 1 | 2 | 3 | 4 | 5 | 6 | 7 | 8 | 9 | 10 | 11 | 12 | 13 | 14 | 15 |
| R | BSY | 0 | DEC_COUNTER[3:0] | | | 0 | 0 | 0 | 0 | 0 | 0 | 0 | 0 | 0 | 0 | 0 |
| W | | | | | | IDFC | ODFC | | | IBIC | OBIC | | DIVRC | OVFC | OVR | IVRC |
| Reset | 0 | 0 | 0 | 0 | 0 | 0 | 0 | 0 | 0 | 0 | 0 | 0 | 0 | 0 | 0 | 0 |
| | 16 | 17 | 18 | 19 | 20 | 21 | 22 | 23 | 24 | 25 | 26 | 27 | 28 | 29 | 30 | 31 |
| R | 0 | 0 | 0 | 0 | 0 | 0 | IDF | ODF | 0 | IBIF | OBIF | 0 | DIVR | OVF | OVR | IVR |
| W | | | | | | | | | | | | | | | | |
| Reset | 0 | 0 | 0 | 0 | 0 | 0 | 0 | 0 | 0 | 0 | 0 | 0 | 0 | 0 | 0 | 0 |

Figure 28-3. Decimation Filter Status Register (DECFLT_x_MSR)
Table 28-5. DECFLT_x_MSR Field Descriptions

| Field | Description |
|--------------------|--|
| 0 BSY | Decimation Filter Busy indication—The BSY bit indicates that the Decimation Filter is actively processing a new input data sample. BSY is not asserted when the filter is disabled (FTYPE = 00). The BSY bit is asserted when the soft reset is executed. 0 Decimation Filter Idle 1 Decimation Filter Busy |
| 1 | Reserved |
| 2–5 DEC_COUNTER | Decimation Counter—The DEC_COUNTER[3:0] field indicates the current value of the DEC_COUNTER Decimation Counter, which counts the number of input data samples received by the Decimation Filter. When the value of this counter matches the DEC_RATE[3:0] Configuration Register field, one decimated result is generated and the DEC_COUNTER counter is re-initialized at zero. This register is cleared by a soft reset or a flush command. |
| 6 IDFC | Input Data Flag Clear bit—The IDFC bit clears the IDF Flag bit in the Status Register. This bit is self negated, therefore it is always read as zero. 0 No action 1 Clears IDF |
| 7 ODFC | Output Data Flag Clear bit—The ODFC bit clears the ODF Flag bit in the Status Register. This bit is self negated, therefore it is always read as zero. 0 No action 1 Clears ODF |
| 8 | Reserved |
| 9 IBIC | Input Buffer Interrupt Request Clear bit—The IBIC bit clears the IBIF Flag bit in the Status Register. This bit is self negated, therefore it is always read as zero. 0 No action 1 Clears IBIF |
| 10 OBIC | Output Buffer Interrupt Request Clear bit—The OBIC bit clears the OBIF Flag bit in the Status Register. This bit is self negated, therefore it is always read as zero. 0 No action 1 Clears OBIF |
| 11 | Reserved |

Table 28-5. DECFILT_x_MSR Field Descriptions (continued)

| Field | Description |
|-------------|---|
| 12 DIVRC | DIVR Clear bit—The DIVRC bit clears the DIVR Debug Filter Input Data Read Overrun indication bit in the Status Register. This bit is self negated, therefore it is always read as zero. 0 No action 1 Clears DIVR |
| 13 OVFC | OVF Clear bit—The OVFC bit clears the OVF Output Overflow bit in the Status Register. This bit is self negated, therefore it is always read as zero. 0 No action 1 Clears OVF |
| 14 OVRC | OVR Clear bit—The OVRC bit clears the OVR Output Overrun bit in the Status Register. This bit is self negated, therefore it is always read as zero. 0 No action 1 Clears OVR |
| 15 IVRC | IVR Clear bit—The IVRC bit clears the IVR Filter Input Overrun indication bit in the Status Register. This bit is self negated, therefore it is always read as zero. 0 No action 1 Clears IVR |
| 16–21 | Reserved |
| 22 IDF | Input Data Flag—The IDF bit flag indicates when new data is available at the DECFILT_x_IB register or at the DECFILT_x_IOB register. This flag generates an Interrupt Request if enabled by the IDEN bit in the Configuration Register. This Flag is cleared by the IDFC Status bit or by a soft reset of the decimation filter. 0 Sample not received 1 New Sample received Note: OBS: This flag is not used for read / write requests. It is used only to announce the input data event. For read / write request flag, refer to IBIF. |
| 23 ODF | Output Data Flag—The ODF bit flag indicates when a new decimated sample is available at the DECFILT_x_OB register or at the DECFILT_x_IOB register. This flag generates an Interrupt Request if enabled by the ODEN bit in the Configuration Register. This Flag is cleared by the ODFC Status bit or by a soft reset of the decimation filter. 0 No new Decimated Output Sample available 1 New Decimated Output Sample available Note: OBS: This flag is not used for read requests. It is used only to announce the output data event. For read request flag, refer to OBIF. |
| 24 | Reserved |
| 25 IBIF | Input Buffer Interrupt Request Flag—The IBIF bit flag indicates that the input buffer DECFILT_x_IB is available to be filled with new data, when Enhanced Debug Monitor is off. In Enhanced Debug Monitor, it indicates the input buffer DECFILT_x_IB was filled with a new sample and is ready to be read. 0 No action 1 New Sample is requested (IO_SEL[1] = 1, EDME=0) or new sample is available in Enhanced Debug Monitor (IO_SEL[1]=0, EDME=1). |
| 26 OBIF | Output Buffer Interrupt Request Flag—The OBIF bit flag indicates that either a new decimated sample is available at the DECFILT_x_OB register. 0 No new Decimated Output available 1 New Decimated Output available |
| 27 | Reserved |

Table 28-5. DECFILT_x_MSR Field Descriptions (continued)

| Field | Description |
|------------|--|
| 28 DIVR | Enhanced Debug Monitor Input Data Read Overrun—The DIVR bit indicates that a received sample in the Filter Interface Input Register was overwritten by a new sample and was not read by the CPU/DMA. This flag generates an Interrupt Request if enabled by the ERREN bit in the Configuration Register. This Flag is cleared by the DIVRC Status bit or by a soft reset of the decimation filter. 0 Input Data Read Overrun did not occur in Enhanced Debug monitor 1 Enhanced Debug Monitor Input Data Read Overrun occurred |
| 29 OVF | Filter Overflow Flag—The OVF bit indicates that an overflow occurred in the filtered sample result. This flag generates an Interrupt Request if enabled by the ERREN bit in the Configuration Register. This Flag is cleared by the OVFC Status bit or by a soft reset of the decimation filter. 0 No overflow 1 Overflow occurred |
| 30 OVR | Output Interface Buffer Overrun—The OVR bit indicates that a decimated sample was overwritten by a new sample in the Interface Output Buffer Register. This flag generates an Interrupt Request if enabled by the ERREN bit in the Configuration Register. This Flag is cleared by the OVRC Status bit or by a soft reset of the decimation filter. 0 No Output Overrun 1 Filter Output Overrun occurred |
| 31 IVR | Input Interface Buffer Overrun—The IVR bit indicates that a received sample in the Filter Interface Input Register was overwritten by a new sample. This flag generates an Interrupt Request if enabled by the ERREN bit in the Configuration Register. This Flag is cleared by the IVRC Status bit or by a soft reset of the decimation filter. 0 Input Buffer Overrun did not occur 1 Input Buffer Overrun occurred Note: |

28.2.2.3 Decimation Filter Module Extended Configuration Register (DECFILT_x_MXCR)

Address: DECFILT_x_BASE + 0x008

Access: User read/write

| | | | | | | | | | | | | | | | | |
|-------|-------|------|---------|-------|----|----|---------|----|----|--------|----|----|----|----|--------|------|
| | 0 | 1 | 2 | 3 | 4 | 5 | 6 | 7 | 8 | 9 | 10 | 11 | 12 | 13 | 14 | 15 |
| R | SDMAE | SSIG | SSAT | SCSAT | 0 | 0 | 0 | 0 | 0 | 0 | 0 | 0 | 0 | 0 | 0 | 0 |
| W | | | | | | | | | | | | | | | SRQ | SZRO |
| Reset | 0 | 0 | 0 | 0 | 0 | 0 | 0 | 0 | 0 | 0 | 0 | 0 | 0 | 0 | 0 | 0 |
| | 16 | 17 | 18 | 19 | 20 | 21 | 22 | 23 | 24 | 25 | 26 | 27 | 28 | 29 | 30 | 31 |
| R | SISEL | 0 | SZROSEL | | 0 | 0 | SHLTSEL | | 0 | SRQSEL | | | 0 | 0 | SENSEL | |
| W | | | | | | | | | | | | | | | | |
| Reset | 0 | 0 | 0 | 0 | 0 | 0 | 0 | 0 | 0 | 0 | 0 | 0 | 0 | 0 | 0 | 0 |

Figure 28-4. Decimation Filter Extended Configuration Register (DECFILT_x_MXCR)

Table 28-6. DECFILT_x_MXCR Field Descriptions

| Field | Description |
|-------------|---|
| 0 SDMAE | <p>Integrator DMA Enable—The SDMAE bit enables the DMA request when an integrator output is available (see Section 28.3.13.2, Integrator Output).</p> <p>0 Integrator DMA request disabled 1 Integrator DMA request enabled</p> <p>Note: The DMA channel used is the same one used for filter outputs, and any configuration that generates DMA requests from both of those sources is not allowed.</p> |
| 1 SSIG | <p>Integrator Signal operation selection—The SSIG bit defines how the filtered data signal is treated for integration:</p> <p>0 Integrator input takes the absolute value of filter output 1 Integrator input takes the signed filter output</p> |
| 2 SSAT | <p>Integrator Saturated operation selection—The SSAT bit defines how the integrator accumulator behaves in case of an overflow.</p> <p>0 Integrator accumulator holds a modulo 2^{17} value (considering the 15-bit fractional part) on an overflow. 1 Integrator accumulator saturates on an overflow</p> <p>Note: In saturated operation the overflowed integration sum holds the value 0xFFFFFFFF for absolute integration (SSIG=0), or values 0x7FFFFFFF (positive saturation) and 0x80000000 (negative saturation) for signed integration (SSIG=1).</p> <p>Note: Non-saturated mode is not supported with signed integration, therefore one must not configure SSIG=1 and SSAT=0.</p> |
| 3 SCSAT | <p>Integrator Counter Saturated operation selection—The SCSAT bit defines how the integrator sample counter behaves in case of an overflow.</p> <p>0 Integrator sample counter holds a modulo 2^{32} value on an overflow. 1 Integrator sample counter saturates on an overflow, holding a value of 0xFFFFFFFF.</p> |
| 4–13 | Reserved |
| 14 SRQ | <p>Integrator Output Request—The SRQ bit is used to command the update of the integrator output, reflected in the registers DECFILT_x_FINTVAL and DECFILT_x_FINTCNT. It may also cause a DMA or interrupt request, depending on the DECFILT_x_MCR bit SDIE and DECFILT_x_MXCR bit SDMAE. This is a write-only bit, so reads always return 0. For more details see Section 28.3.13.2, Integrator Output.</p> <p>0 No integrator output update request 1 Requests integrator output update</p> |
| 15 SZRO | <p>Integrator Zero—The SZRO bit is used to zero the integrator sum. This is a write-only bit, reads always return 0. For more details see Section 28.3.13.3, Integrator Reset.</p> <p>0 Does not zero integrator sum 1 Zeroes integrator sum</p> <p>Note: If bits SRQ and SZRO are both written 1 at the same time, the integrator is reset only after the registers DECFILT_x_FINTVAL and DECFILT_x_FINTCNT are updated.</p> |
| 16 SISEL | <p>Integrator Input Selection—The SISEL bit selects the input of the integrator. For more details see Section 28.3.13.1, Integrator Inputs.</p> <p>0 Decimated filter outputs feed the integrator 1 Filter outputs before the decimation feed the integrator</p> |
| 17 | Reserved |

Table 28-6. DECFILT_x_MXCR Field Descriptions (continued)

| Field | Description | | | | | | | | | | | | | | | | | | |
|------------------|--|--------------|-------------|-------|---|-------|---|-------|---|-------|--|-------|----------|-------|--|-------|--|-------|--|
| 18–19 SZROSEL | Integrator Zero Control Mode Selection—The SZROSEL field defines the use of the integrator zero hardware input signal. For more details see Section 28.3.13.3, Integrator Reset . <table border="1" style="margin-left: 40px;"> <thead> <tr> <th>SZROSEL[1:0]</th> <th>Description</th> </tr> </thead> <tbody> <tr> <td>0 0</td> <td>Hardware integrator zero request disabled</td> </tr> <tr> <td>0 1</td> <td>Integrator zero on toggle of hardware signal</td> </tr> <tr> <td>1 0</td> <td>Integrator zero on rising edge of hardware signal</td> </tr> <tr> <td>1 1</td> <td>Integrator zero on falling edge of hardware signal</td> </tr> </tbody> </table> | SZROSEL[1:0] | Description | 0 0 | Hardware integrator zero request disabled | 0 1 | Integrator zero on toggle of hardware signal | 1 0 | Integrator zero on rising edge of hardware signal | 1 1 | Integrator zero on falling edge of hardware signal | | | | | | | | |
| SZROSEL[1:0] | Description | | | | | | | | | | | | | | | | | | |
| 0 0 | Hardware integrator zero request disabled | | | | | | | | | | | | | | | | | | |
| 0 1 | Integrator zero on toggle of hardware signal | | | | | | | | | | | | | | | | | | |
| 1 0 | Integrator zero on rising edge of hardware signal | | | | | | | | | | | | | | | | | | |
| 1 1 | Integrator zero on falling edge of hardware signal | | | | | | | | | | | | | | | | | | |
| 20–21 | Reserved | | | | | | | | | | | | | | | | | | |
| 22–23 SHLTSEL | Integrator Halt Control Selection—The SHLTSEL field defines the integrator halting mechanism. When the integrator is halted, the integration accumulator remains unaltered on filter outputs independently of the enabling selected by SENSEL. For more details see Section 28.3.13.4, Integrator Enabling and Halting . <table border="1" style="margin-left: 40px;"> <thead> <tr> <th>SHLTSEL[1:0]</th> <th>Description</th> </tr> </thead> <tbody> <tr> <td>0 0</td> <td>Hardware halt control signal disabled</td> </tr> <tr> <td>0 1</td> <td>Integrator halted, independently of the hardware signal</td> </tr> <tr> <td>1 0</td> <td>Integrator halted when signal is at logical 0</td> </tr> <tr> <td>1 1</td> <td>Integrator halted when signal is at logical 1</td> </tr> </tbody> </table> | SHLTSEL[1:0] | Description | 0 0 | Hardware halt control signal disabled | 0 1 | Integrator halted, independently of the hardware signal | 1 0 | Integrator halted when signal is at logical 0 | 1 1 | Integrator halted when signal is at logical 1 | | | | | | | | |
| SHLTSEL[1:0] | Description | | | | | | | | | | | | | | | | | | |
| 0 0 | Hardware halt control signal disabled | | | | | | | | | | | | | | | | | | |
| 0 1 | Integrator halted, independently of the hardware signal | | | | | | | | | | | | | | | | | | |
| 1 0 | Integrator halted when signal is at logical 0 | | | | | | | | | | | | | | | | | | |
| 1 1 | Integrator halted when signal is at logical 1 | | | | | | | | | | | | | | | | | | |
| 24 | Reserved | | | | | | | | | | | | | | | | | | |
| 25–27 SRQSEL | Integrator Output Read Request Mode Selection—The SRQSEL field defines the use of the integrator output request hardware input signal. An integrator output request updates the registers DECFILT_x_FINTVAL and DECFILT_x_FINTCNT, also causing a DMA or interrupt request. Note that DMA or interrupt requests due to integrator output updates depend on the DECFILT_x_MXCR bit SDMAE and DECFILT_x_MCR bit SDIE. When continuous output is on, an integrator output request is issued whenever a new filter output is accumulated. For more details see Section 28.3.13.2, Integrator Output . <table border="1" style="margin-left: 40px;"> <thead> <tr> <th>SRQSEL[2:0]</th> <th>Description</th> </tr> </thead> <tbody> <tr> <td>0 0 0</td> <td>Hardware output request disabled</td> </tr> <tr> <td>0 0 1</td> <td>Integrator output request on toggle of hardware signal</td> </tr> <tr> <td>0 1 0</td> <td>Integrator output request on rising edge of hardware signal</td> </tr> <tr> <td>0 1 1</td> <td>Integrator output request on falling edge of hardware signal</td> </tr> <tr> <td>1 0 0</td> <td>Reserved</td> </tr> <tr> <td>1 0 1</td> <td>Continuous output request on, independently of hardware signal</td> </tr> <tr> <td>1 1 0</td> <td>Continuous output request on when signal is at logical 0</td> </tr> <tr> <td>1 1 1</td> <td>Continuous output request on when signal is at logical 1</td> </tr> </tbody> </table> | SRQSEL[2:0] | Description | 0 0 0 | Hardware output request disabled | 0 0 1 | Integrator output request on toggle of hardware signal | 0 1 0 | Integrator output request on rising edge of hardware signal | 0 1 1 | Integrator output request on falling edge of hardware signal | 1 0 0 | Reserved | 1 0 1 | Continuous output request on, independently of hardware signal | 1 1 0 | Continuous output request on when signal is at logical 0 | 1 1 1 | Continuous output request on when signal is at logical 1 |
| SRQSEL[2:0] | Description | | | | | | | | | | | | | | | | | | |
| 0 0 0 | Hardware output request disabled | | | | | | | | | | | | | | | | | | |
| 0 0 1 | Integrator output request on toggle of hardware signal | | | | | | | | | | | | | | | | | | |
| 0 1 0 | Integrator output request on rising edge of hardware signal | | | | | | | | | | | | | | | | | | |
| 0 1 1 | Integrator output request on falling edge of hardware signal | | | | | | | | | | | | | | | | | | |
| 1 0 0 | Reserved | | | | | | | | | | | | | | | | | | |
| 1 0 1 | Continuous output request on, independently of hardware signal | | | | | | | | | | | | | | | | | | |
| 1 1 0 | Continuous output request on when signal is at logical 0 | | | | | | | | | | | | | | | | | | |
| 1 1 1 | Continuous output request on when signal is at logical 1 | | | | | | | | | | | | | | | | | | |

Table 28-6. DECFILT_x_MXCR Field Descriptions (continued)

| Field | Description | | | | | | | | | | |
|-----------------|--|-------------|-------------|-----|--|-----|--|-----|--|-----|--|
| 28–29 | Reserved | | | | | | | | | | |
| 30–31 SENSEL | Integrator Enable Control Selection—The SENSEL field defines the integrator enabling mechanism. When the integrator is enabled, filter outputs selected by the SISEL bit are added to the integration accumulator. When the integrator is disabled, the integration accumulator remains unaltered on filter outputs. For more details see Section 28.3.13.4, Integrator Enabling and Halting . | | | | | | | | | | |
| | <table border="1"> <thead> <tr> <th>SENSEL[1:0]</th> <th>Description</th> </tr> </thead> <tbody> <tr> <td>0 0</td> <td>Integrator disabled, independently of the hardware enable control signal</td> </tr> <tr> <td>0 1</td> <td>Integrator enabled, independently of the hardware signal</td> </tr> <tr> <td>1 0</td> <td>Integrator enabled when signal is at logical 0</td> </tr> <tr> <td>1 1</td> <td>Integrator enabled when signal is at logical 1</td> </tr> </tbody> </table> | SENSEL[1:0] | Description | 0 0 | Integrator disabled, independently of the hardware enable control signal | 0 1 | Integrator enabled, independently of the hardware signal | 1 0 | Integrator enabled when signal is at logical 0 | 1 1 | Integrator enabled when signal is at logical 1 |
| SENSEL[1:0] | Description | | | | | | | | | | |
| 0 0 | Integrator disabled, independently of the hardware enable control signal | | | | | | | | | | |
| 0 1 | Integrator enabled, independently of the hardware signal | | | | | | | | | | |
| 1 0 | Integrator enabled when signal is at logical 0 | | | | | | | | | | |
| 1 1 | Integrator enabled when signal is at logical 1 | | | | | | | | | | |

28.2.2.4 Decimation Filter Module Extended Status Register (DECFILT_x_MXSR)

Address: DECFILT_x_BASE + 0x00C

Access: User read/write

| | | | | | | | | | | | | | | | | |
|-------|----|----|----|----|----|----|----|------|----|----|------|------|----|------------|------------|------|
| | 0 | 1 | 2 | 3 | 4 | 5 | 6 | 7 | 8 | 9 | 10 | 11 | 12 | 13 | 14 | 15 |
| R | 0 | 0 | 0 | 0 | 0 | 0 | 0 | 0 | 0 | 0 | 0 | 0 | 0 | 0 | 0 | 0 |
| W | | | | | | | | SDFC | | | SSEC | SCEC | | SSOVF C | SCOVF C | SVRC |
| Reset | 0 | 0 | 0 | 0 | 0 | 0 | 0 | 0 | 0 | 0 | 0 | 0 | 0 | 0 | 0 | 0 |
| | 16 | 17 | 18 | 19 | 20 | 21 | 22 | 23 | 24 | 25 | 26 | 27 | 28 | 29 | 30 | 31 |
| R | 0 | 0 | 0 | 0 | 0 | 0 | 0 | SDF | 0 | 0 | SSE | SCE | 0 | SSOVF | SCOVF | SVR |
| W | | | | | | | | | | | | | | | | |
| Reset | 0 | 0 | 0 | 0 | 0 | 0 | 0 | 0 | 0 | 0 | 0 | 0 | 0 | 0 | 0 | 0 |

Figure 28-5. Decimation Filter Extended Status Register (DECFILT_x_MXSR)

Table 28-7. DECFILT_x_MXSR Field Descriptions

| Field | Description |
|-----------|--|
| 0–6 | Reserved |
| 7 SDFC | Integrator Output Data Flag Clear bit—The SDFC bit clears the SDF Flag bit in the Status Register. This bit is self negated, therefore it is always read as zero. 0 No action 1 Clears SDF |
| 8–9 | Reserved |

Table 28-7. DECFILT_x_MXSR Field Descriptions (continued)

| Field | Description |
|--------------|---|
| 10 SSEC | SSEC — Integrator Sum Exception Clear bit—The SSEC bit clears the SSE flag bit in the Status Register. This bit is self negated, therefore it is always read as zero. 0 No action 1 Clears SSE |
| 11 SCEC | Integrator Count Exception Clear bit—The SCEC bit clears the SCE flag bit in the Status Register. This bit is self negated, therefore it is always read as zero. 0 No action 1 Clears SCE |
| 12 | Reserved |
| 13 SSOVFC | Integrator Sum Overflow Clear bit—The SSOVFC bit clears the SSOVF Flag bit in the Status Register. This bit is self negated, therefore it is always read as zero. 0 No action 1 Clears SSOVF |
| 14 SCOVFC | Integrator Count Overflow Clear bit—The SCOVFC bit clears the SCOVF Flag bit in the Status Register. This bit is self negated, therefore it is always read as zero. 0 No action 1 Clears SCOVF |
| 15 SVRC | SVR Clear bit—The SVRC bit clears the SVR Integrator Data Overrun indication bit in the Status Register. This bit is self negated, therefore it is always read as zero. 0 No action 1 Clears SVR |
| 16–22 | Reserved |
| 23 SDF | Integrator Data Flag—The SDF bit flag indicates when a new integrator result is available at the DECFILT_x_FINTVAL register. This flag generates an Interrupt Request if enabled by the SDIE bit in the Configuration Register. This Flag is cleared by the SDFC Status bit or by a soft reset of the decimation filter. 0 No new integrator result available 1 New integrator result available |
| 24–25 | Reserved |
| 26 SSE | Integrator Sum Exception flag—The SSE bit indicates an exceptional condition of the integrator accumulator. This flag generates an Interrupt Request if enabled by the DECFILT_x_MCR bit ERREN, and it is cleared by the SSEC bit or by a soft reset. Integrator exceptions are defined in Section 28.3.13.5, Integrator Exceptions . 0 No exception in the integrator accumulator. 1 Integrator accumulator exception. |
| 27 SCE | Integrator Count Exception flag—The SCE bit indicates an exceptional condition of the integrator counter. This flag generates an Interrupt Request if enabled by the DECFILT_x_MCR bit ERREN, and it is cleared by the SCEC bit or by a soft reset. Integrator exceptions are defined in Section 28.3.13.5, Integrator Exceptions . 0 No exception in the integrator counter. 1 Integrator counter exception. |
| 28 | Reserved |

Table 28-7. DECFILT_x_MXSR Field Descriptions (continued)

| Field | Description |
|---------------------|---|
| <p>29 SSOVF</p> | <p>Integrator Sum Overflow Flag—The SSOVF bit indicates an overflow of the integrator accumulator. This Flag is cleared by the SSOVFC bit or by a soft reset.</p> <p>0 No overflow in the integrator accumulator. 1 Integrator accumulator overflow.</p> <p>Note: The SSOVF bit samples the integrator accumulator overflow condition when and only when either registers DECFILT__FINTVAL or DECFILT__CINTCNT are updated. Therefore, only one of the register pairs (DECFILT_x_FINTVAL/DECFILT_x_FINTCNT and DECFILT_x_CINTVAL/DECFILT_x_CINTCNT) must be used by the application, in order to avoid races.</p> |
| <p>30 SCOVF</p> | <p>Integrator Count Overflow Flag—The SCOVF bit flag indicates an overflow of the internal integrated sample counter. This Flag is cleared by the SCOVFC bit or by a soft reset.</p> <p>0 No overflow in the integrator sample counter. 1 Integrator sample counter overflow.</p> <p>Note: The SCOVF bit samples the integrator accumulator overflow condition when and only when either registers DECFILT_x_FINTVAL or DECFILT_x_CINTCNT are updated. Therefore, only one of the register pairs (DECFILT_x_FINTVAL/DECFILT_x_FINTCNT and DECFILT_x_CINTVAL/DECFILT_x_CINTCNT) must be used by the application, in order to avoid races.</p> |
| <p>31 SVR</p> | <p>Integrator Data Overrun—The SVR bit indicates that an integration value and count in the registers DECFILT_x_FINTVAL and DECFILT_x_FINTCNT was overwritten by a new integrator output request and was not read by the CPU or DMA. This flag generates an Interrupt Request if enabled by the ERREN bit in the Configuration Register. This Flag is cleared by the SVRC bit or by a soft reset.</p> <p>0 Integrator Data Overrun did not occur. 1 Integrator Data Overrun occurred.</p> |

28.2.2.5 Decimation Filter Interface Input Buffer Register (DECFLT_x_IB)

The Input Buffer Register provides access to the Input buffer of the decimation filter when the filter is receiving input data from the CPU/DMA (DECFLT_x_MCR[IO_SEL[1]] = 1). Writes to this register are interpreted as requests to the Decimation Filter to process new sample data. Writes to this register when DECFLT_x_MCR[IO_SEL[1]] = 0 have no effect.

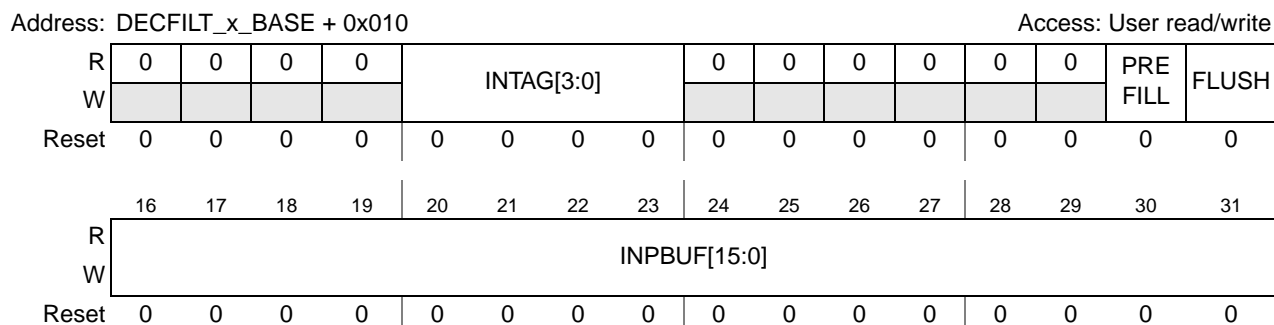

Figure 28-6. Decimation Filter Interface Input Buffer Register (DECFLT_x_IB)

Table 28-8. DECFLT_x_IB Field Descriptions

| Field | Description |
|-----------------|--|
| 0–3 | Reserved |
| 4–7 INTAG | Decimation filter input tag bits—The INTAG[3:0] bit field is defined as a selector signal and it is used to identify different destinations for the INBUF[15:0] data. When the input data source is the CPU/DMA and the output destination is an eQADC, INTAG is used to address the appropriate RFIFO in the eQADC block. |
| 8–13 | Reserved |
| 14 PREFILL | Decimation Filter Prefill/Filter control bit—The PREFILL bit selects the Decimation Filter operation mode. For more details, see Section 28.3.4, Filter Prefill Control . 0 Decimation Filter normal sample 1 Decimation Filter prefill sample |
| 15 FLUSH | Decimation Filter Flush control bit—Assertion of the FLUSH bit initializes the Decimation Filter to a initial state, as defined in Section 28.3.6, Flush Command . This bit is self negated and it is cleared only when the data is read and the flush is executed. 0 No flush request 1 Flush request |
| 16–31 INPBUF | Input Buffer Data—The INPBUF[15:0] bit field carries the sample data to be filtered. This data buffer can be written from the eQADC or by the CPU/DMA. See Section 28.3.1, Decimation Filter Input , for more details. |

28.2.2.6 Decimation Filter Interface Output Buffer Register (DECFLT_x_OB)

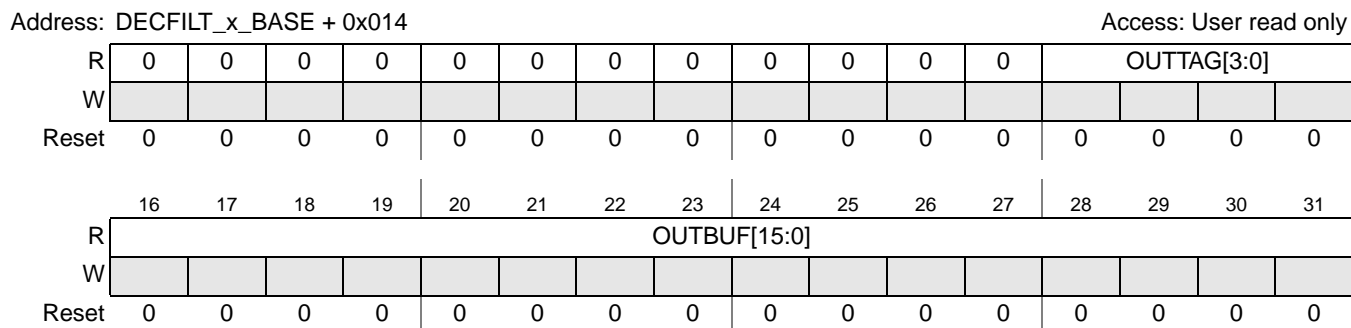

Figure 28-7. Decimation Filter Interface Output Buffer Register (DECFLT_x_OB)

Table 28-9. DECFLT_x_OB Field Descriptions

| Field | Description |
|-----------------|---|
| 0–11 | Reserved |
| 12–15 OUTTAG | Decimation filter output tag bits—The OUTTAG[3:0] bit field is defined as a selector signal and it is used to identify different destinations for the OUTBUF[15:0] data. When the output result destination is an eQADC, OUTTAG holds the same value as the DECFLT_x_IB[INTAG], which is used to address the destination RFIFO. |
| 16–31 OUTBUF | Output Buffer Data—The OUTPBUF[15:0] bit field is the result data in the decimation filter Output Buffer. It represents a fixed point signed number in two's complement format and is updated only when a decimated result is ready to be transmitted, meaning it contains the last decimated result from the filter. |

28.2.2.7 Decimation Filter Coefficient n Register (DECFLT_x_COEFn)

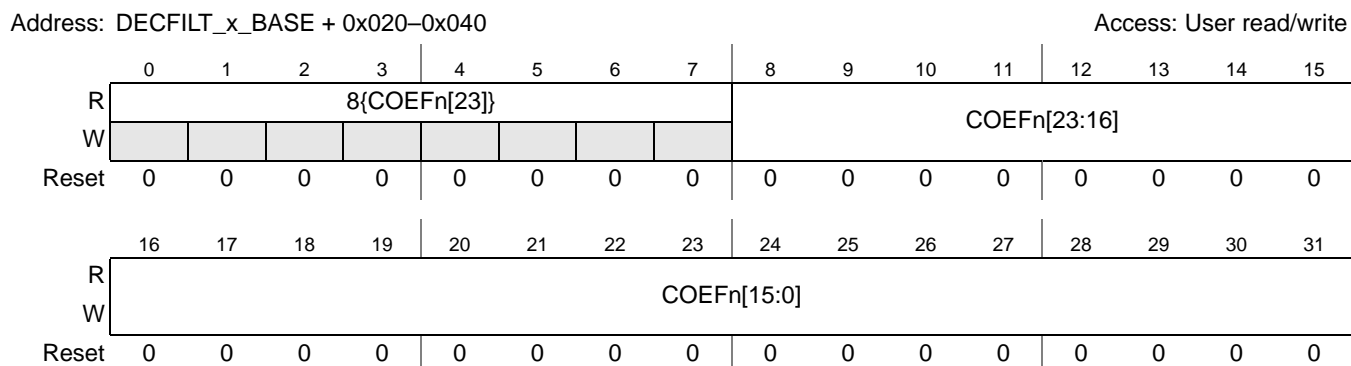

Figure 28-8. Decimation Filter Coefficient n Register (DECFLT_x_COEFn)

Table 28-10. DECFILT_x_COEFn Field Descriptions

| Field | Description |
|---------------|---|
| 0–31 COEFn | Coefficient n field—The COEFn[23:0] bit fields are the digital filter coefficients registers. The coefficients are fractional signed values in two's complement format, in the range $(-1 \leq \text{coef} < 1)$. Note: Reads to this register are sign-extended, meaning the coefficient's sign bit is copied to all 8 most significant register bits. Note: Writing to these fields when BSY=1 is not allowed. |

28.2.2.8 Decimation Filter TAPn Register (DECFILT_x_TAPn)

Address: DECFILT_x_BASE + 0x078–0x094

Access: User read only

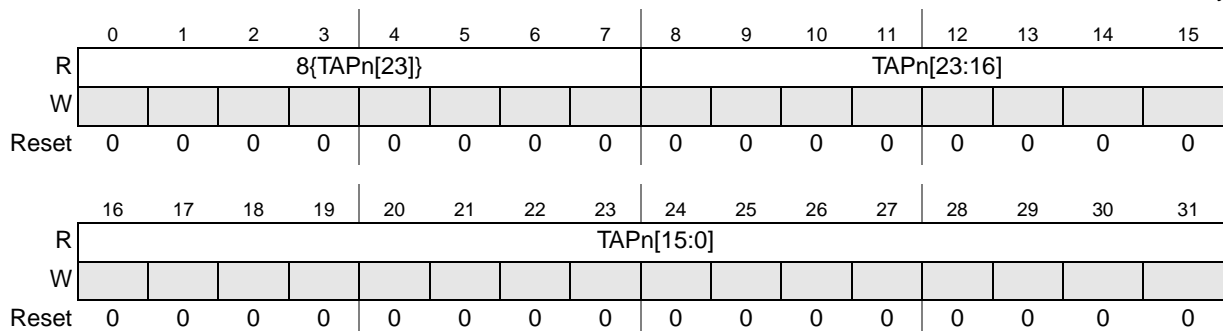
Figure 28-9. Decimation Filter TAPn Register (DECFILT_x_TAPn)
Table 28-11. DECFILT_x_TAPn Field Descriptions

| Field | Description |
|--------------|--|
| 0–31 TAPn | TAPn Register—The read-only TAPn[23:0] bit fields shows the contents of the digital filter tap registers, as fractional signed values in two's complement format, in the range $(-1 \leq \text{coef} < 1)$. The tap registers hold the input data delay line ($X_n, X_{n-1}, \dots, X_{n-7}$ for 8th order FIR). Note: Reads to this register are sign-extended, meaning the coefficient's sign bit is copied to all 8 most significant register bits. Note: The content of these registers is meaningless when BSY=1. |

28.2.2.9 Decimation Filter Interface Enhanced Debug Input Data Register (DECFLT_x_EDID)

The Enhanced Debug Input Data Register provides read-only access to the sample data received by the Decimation Filter when the input is selected from an eQADC module (DECFLT_x_MCR[IO_SEL[1]] = 0), allowing the monitoring of input data from an eQADC. See [Section 28.3.15, Enhanced Debug Monitor Description](#) for more details, and see [Section 28.3.12.1.2, Input Buffer Enhanced Debug Monitor Interrupt](#) and [Section 28.3.12.1.4, Input Buffer Enhanced Debug Monitor DMA Request](#) for more information on interrupt and DMA requests associated with the Enhanced Debug Monitor. Writes to this register have no effect.

Address: DECFLT_x_BASE + 0x0D0 Access: User read only

| | | | | | | | | | | | | | | | | |
|-------|-----------------|----|----|----|----|----|----|----|----|----|----|----|----|----|----|----|
| | 0 | 1 | 2 | 3 | 4 | 5 | 6 | 7 | 8 | 9 | 10 | 11 | 12 | 13 | 14 | 15 |
| R | 0 | 0 | 0 | 0 | 0 | 0 | 0 | 0 | 0 | 0 | 0 | 0 | 0 | 0 | 0 | 0 |
| W | | | | | | | | | | | | | | | | |
| Reset | 0 | 0 | 0 | 0 | 0 | 0 | 0 | 0 | 0 | 0 | 0 | 0 | 0 | 0 | 0 | 0 |
| | | | | | | | | | | | | | | | | |
| | 16 | 17 | 18 | 19 | 20 | 21 | 22 | 23 | 24 | 25 | 26 | 27 | 28 | 29 | 30 | 31 |
| R | SAMP_DATA[15:0] | | | | | | | | | | | | | | | |
| W | | | | | | | | | | | | | | | | |
| Reset | 0 | 0 | 0 | 0 | 0 | 0 | 0 | 0 | 0 | 0 | 0 | 0 | 0 | 0 | 0 | 0 |

Figure 28-10. Decimation Filter Interface Input Buffer Register (DECFLT_x_EDID)

Table 28-12. DECFLT_x_EDID Field Descriptions

| Field | Description |
|--------------------|--|
| 0–15 | Reserved |
| 16–31 SAMP_DATA | Conversion Sample Data—The SAMP_DATA[15:0] bit field carries the data that was loaded into the Decimation Filter input buffer to be processed by the FIR/IIR sub-block. This value is only updated by input data received from an eQADC (DECFLT_x_MCR[IO_SEL[1]] = 0), and the Enhanced Debug Monitor is enabled (DECFLT_x_MCR[EDME] = 1). |

28.2.2.10 Decimation Filter Final Integration Value Register (DECFLT_x_FINTVAL)

Address: DECFLT_x_BASE + 0x0E0 Access: User read only

| | | | | | | | | | | | | | | | | |
|-------|------------------|----|----|----|----|----|----|----|----|----|----|----|----|----|----|----|
| | 0 | 1 | 2 | 3 | 4 | 5 | 6 | 7 | 8 | 9 | 10 | 11 | 12 | 13 | 14 | 15 |
| R | SUM_VALUE[31:16] | | | | | | | | | | | | | | | |
| W | | | | | | | | | | | | | | | | |
| Reset | 0 | 0 | 0 | 0 | 0 | 0 | 0 | 0 | 0 | 0 | 0 | 0 | 0 | 0 | 0 | 0 |
| | | | | | | | | | | | | | | | | |
| | 16 | 17 | 18 | 19 | 20 | 21 | 22 | 23 | 24 | 25 | 26 | 27 | 28 | 29 | 30 | 31 |
| R | SUM_VALUE[15:0] | | | | | | | | | | | | | | | |
| W | | | | | | | | | | | | | | | | |
| Reset | 0 | 0 | 0 | 0 | 0 | 0 | 0 | 0 | 0 | 0 | 0 | 0 | 0 | 0 | 0 | 0 |

Figure 28-11. Decimation Filter Final Integration Value Register (DECFLT_x_FINTVAL)

Table 28-13. DECFILT_x_FINTVAL Field Descriptions

| Field | Description |
|-------------------|--|
| 0–31 SUM_VALUE | <p>Integration Sum Value—The SUM_VALUE[31:0] field holds the sum of filtered output values. The 17 most significant bits hold the integer part, and the 15 least significant ones the fractional part of the integration value. The control of the integration sum and update of this register is determined by the register DECFILT_x_MXCR (see Section 28.2.2.3, Decimation Filter Module Extended Configuration Register (DECFILT_x_MXCR)). The register is updated only upon an integration output request.</p> <p>SUM_VALUE should be taken as an unsigned number when the integrator is configured for absolute operation (DECFILTER_MXCR bit SSIG=0), and a two's complement signed number otherwise.</p> <p>Note: If SSAT=0, DECFILT_x_FINTVAL holds the integration sum modulo 2^{17} (considering the 15-bit fractional part).</p> <p>Note: If SSAT=1, the integration sum is saturated, so that if the accumulation overflows DECFILT_x_FINTVAL holds the value 0xFFFFFFFF for absolute integration (SSIG=0), or values 0x7FFFFFFF (positive saturation) and 0x80000000 (negative saturation) for signed integration (SSIG=1).</p> |

28.2.2.11 Decimation Filter Final Integration Count Value Register (DECFILT_x_FINTCNT)

Address: DECFILT_x_BASE + 0x0E4

Access: User read only

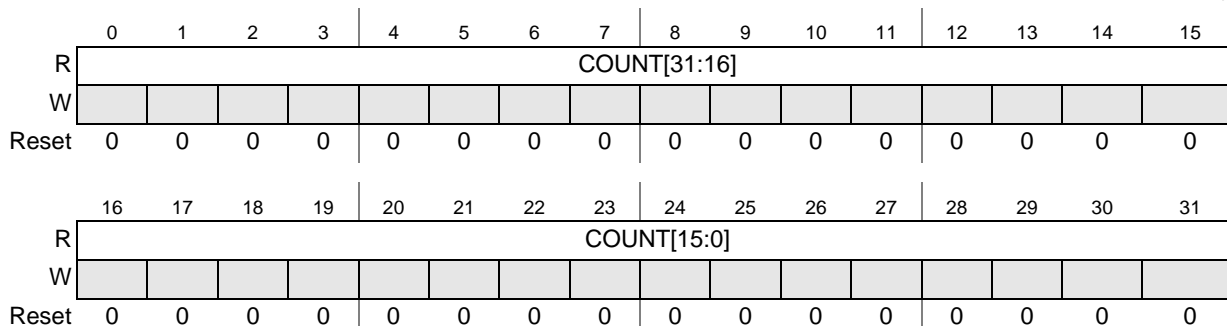
Figure 28-12. Decimation Filter Final Integration Count Value Register (DECFILT_x_FINTCNT)
Table 28-14. DECFILT_x_FINTCNT Field Descriptions

| Field | Description |
|---------------|---|
| 0–31 COUNT | <p>Integration Count Value—The COUNT field holds the count of filtered outputs integrated. The control of the integration sum and update of this register is determined by the register DECFILT_x_MXCR. The register is updated together with DECFILT_x_FINTVAL, only upon an integration output request.</p> |

28.2.2.12 Decimation Filter Current Integration Value Register (DECFLT_x_CINTVAL)

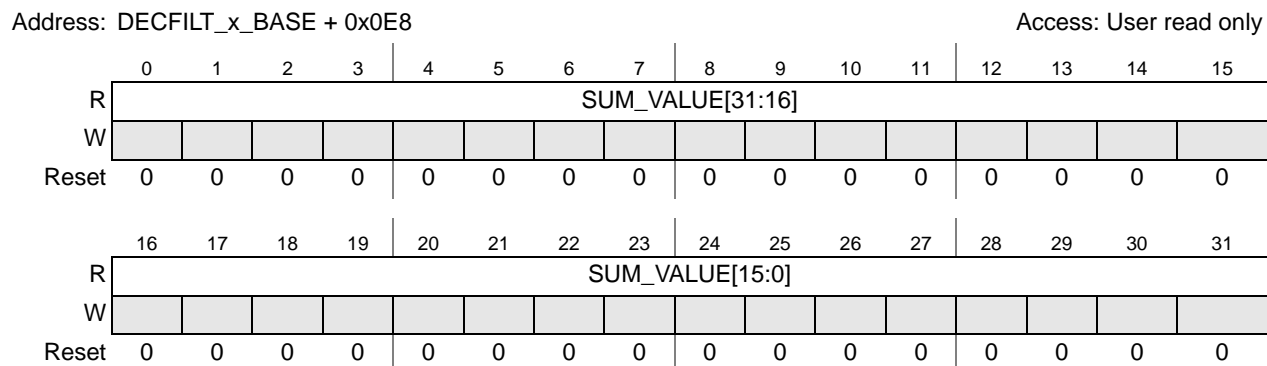

Figure 28-13. Decimation Filter Current Integration Value Register (DECFLT_x_CINTVAL)

Table 28-15. DECFLT_x_CINTVAL Field Descriptions

| Field | Description |
|-------------------|--|
| 0–31 SUM_VALUE | Integration Sum Value—The SUM_VALUE[31:0] field holds an unsigned number representing the sum of filtered output values, continuously updated as the integration proceeds. The control of the integration sum is determined by the register DECFLT_x_MXCR (see Section 28.2.2.3, Decimation Filter Module Extended Configuration Register (DECFLT_x_MXCR)). |

28.2.2.13 Decimation Filter Current Integration Count Value Register (DECFLT_x_CINTCNT)

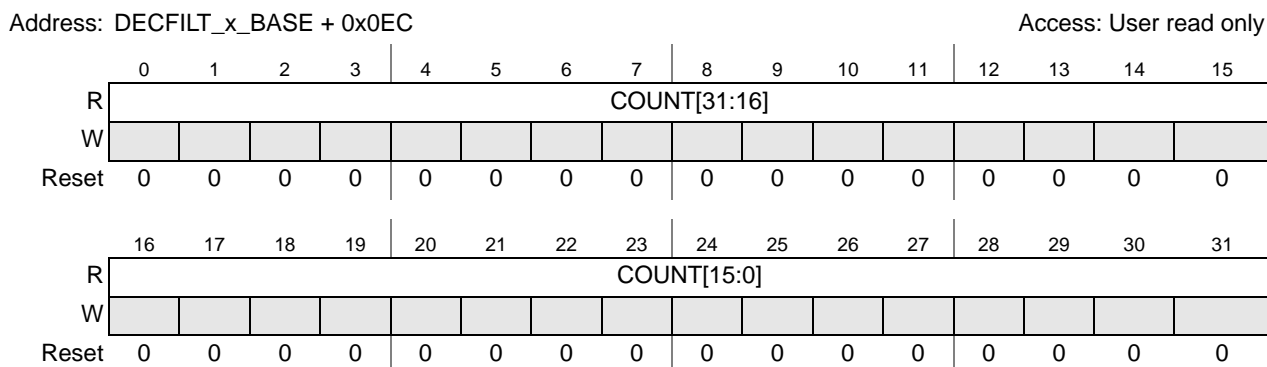

Figure 28-14. Decimation Filter Current Integration Count Value Register (DECFLT_x_CINTCNT)

Table 28-16. DECFLT_x_CINTCNT Field Descriptions

| Field | Description |
|---------------|---|
| 0–31 COUNT | Integration Count Value—The COUNT field holds the count of filtered outputs integrated. The value is updated only when register DECFLT_x_CINTVAL is read, to keep the coherency between the integration and count values. |

28.3 Functional Description

The following subsections describe the functional operation of a single block and apply to all Decimation Filter blocks on the device.

28.3.1 Decimation Filter Input

The Decimation Filter receives input data from either the an eQADC block, or from the CPU using the memory mapped `DECFLT_x_IB` register. The data source is selected by the `DECFLT_x_MCR[IO_SEL[1]]` bit. Note that when the Decimation Filters are cascaded, filters other than the head filter receive input from the adjacent filter. See [Section 28.3.14, Cascade Mode](#), for more information on cascade operation.

An interrupt or DMA request can be generated when the input buffer is empty, and the input data source is the CPU or DMA. A DMA request is generated when the `DECFLT_x_MCR[DSEL] = 1`, and the input buffer becomes empty. If DMA is not enabled, an interrupt is generated by setting the `DECFLT_x_MCR[IBIE] = 1`. If both an interrupt and DMA request are enabled, the DMA takes precedence.

An interrupt can also be generated when the input buffer is written with a new value. This interrupt is enabled by the `DECFLT_x_MCR[IDEN]` bit. When enabled and data is written to the filter input buffer, the `DECFLT_x_MSR[IDF]` bit is set. The IDF flag remains set, even after the input data has been consumed by the filter and the buffer is free, until IDF is cleared by software write to the IDFC bit.

See [Section 28.3.12, Interrupts and DMA Overview](#), for more information on interrupt and DMA requests.

28.3.1.1 Input Buffer Overrun

An input overrun occurs when the input buffer is holding input data and new data is received by the filter. See [Section 28.3.1, Decimation Filter Input](#), for details of the input buffer. When the decimation filter is idle (`DECFLT_x_MSR[BSY] = 0`) the filter can receive two consecutive input buffer writes without input overrun. Input buffer overrun is detected and flagged by the `DECFLT_x_MSR[IVR]` bit. The overrun interrupt is enabled by the `DECFLT_x_MCR[ERREN]` bit.

The input buffer overrun can occur only in the following cases:

- When the input buffer has sample data to be processed but the filter is busy and another input (data or timestamp) is received.
- When the input buffer has a timestamp, the internal timestamp register is loaded and the next input data is received.

As an example of the input data sequence, assume that the filter is enabled and not busy, and all registers are empty. Then a word of sample data is received followed by a timestamp and another word of sample data. No input overrun occurs in this case, because the first sample is immediately transferred to the tap input register, the timestamp is immediately transferred to the internal timestamp storage register, and the second sample can be held in the input buffer until the end of the processing of the first sample data by the filter. The input overrun may occur if more input is received before the end of the processing, or if the filter is busy at the beginning of the received sequence.

When the filter is bypassed (`DECFLT_x_MCR[FTYPE] = 0b00`) or in disable mode, the data from the input buffer is transferred to the output buffer, if it is not already full. If the output buffer is full, the input buffer is loaded, and another word of input data is sent, then an input overrun occurs.

28.3.2 Decimation Filter Output

NOTE

Decimation Filter H is not writeable or readable from the eQADC, only by DMA or the CPU. All other decimation filters have no limitations.

The Decimation Filter can send filtered results directly to an eQADC, or to the CPU using the memory mapped `DECFLT_x_OB` output buffer register. The output destination for the filter result is determined by the `DECFLT_x_MCR[IO_SEL]` field. The filter result is written to the output buffer register when the decimation count is reached (either an eQADC or CPU destination). The `DECFLT_x_MSR[ODF]` flag bit is set when the output buffer is updated. When an eQADC is selected for the result destination, the result is automatically transferred to an eQADC FIFO when the output buffer is updated.

The output buffer is not updated when the Decimation Filter is in prefill mode, so the `DECFLT_x_MSR[ODF]` flag is not set in that case.

An interrupt or DMA request can be generated when the output buffer is updated, and the output result destination is the CPU or DMA. A DMA request is generated when the `DECFLT_x_MCR[DSEL] = 1`, and the output buffer is updated. If DMA is not enabled, an interrupt is generated by setting the `DECFLT_x_MCR[OBIE] = 1`. If both an interrupt and DMA request are enabled, the DMA takes precedence.

When the filter is bypassed (`DECFLT_x_MCR[FTYPE]=0b00`), and the eQADC is selected as the output destination, the data written into the input buffer is delayed until the output buffer is empty and then written to the output buffer. When the filter is bypassed and the memory mapped register is selected as the output destination, the data written into the input buffer is immediately written into the output buffer, and the `DECFLT_x_MSR[ODF]` flag is set.

A Soft Reset (`DECFLT_x_MSR[SRES]`) clears the output buffer, and terminates output data transfer to the output buffer.

28.3.2.1 Output Buffer Overrun

An output overrun occurs when the output buffer (`DECFLT_x_OB`) is holding output data (sample or timestamp) that has not been read and it is overwritten with subsequent data (sample or timestamp). Output overruns are flagged by the `DECFLT_x_MSR[OVR]` bit. An output buffer overrun interrupt is enabled by the `DECFLT_x_MCR[ERREN]` bit. The output buffer empty condition depends on the mode and output selection as follows:

- When the output result destination is an eQADC, the output buffer is considered empty when the filter output transfer to an eQADC FIFO is complete.
- When the output result destination is the CPU/DMA, the output buffer is considered empty after the buffer has been read and the `DECFLT_x_MSR[ODF]` flag is cleared.

Prefill inputs do not cause IIR or FIR output overrun for either output destination selection.

When bypass mode is selected, an output overrun cannot occur because the data written into the input buffer (DECFLT_x_IB) is written into the output buffer (DECFLT_x_OB) only when this buffer is empty, but an input overrun may still occur (see [Section 28.3.1.1, Input Buffer Overrun](#)).

28.3.3 Bypass Operation

Bypass operation is configured by setting the field FTYPE[1:0] of the Module Configuration Register DECFLT_x_MCR to 00. In this case, the input sample is sent to the output with no change. This behavior is independent of input data source or output result destination selections. The following applies to the bypass configuration:

- flush is ignored
- prefill is ignored
- decimation is ignored
- BSY bit is not set
- the input flag DECFLT_x_MSR[IDF] and output flag DECFLT_x_MSR[ODF] are set

28.3.4 Filter Prefill Control

A prefill indicates that the input data should be accepted by the Decimation Filter, but no decimated output should be generated while the control field indicates prefill. Therefore the prefill function is used in the beginning of the filter operation to initialize and stabilize the Decimation Filter without generating decimated samples. In addition, the prefill does not operate when the filter is in bypass (FTYPE=0b00).

When the input data source is an eQADC (DECFLT_x_MCR[IO_SEL[1]] = 0), prefill is enabled/disabled in the eQADC conversion command word (CCW). See [Section 28.4.1, eQADC Configuration for Decimation Filter Operation](#) for more information on an eQADC configuration of decimation filter functionality. When the input data source is the CPU/DMA (DECFLT_x_MCR[IO_SEL[1]] = 1), prefill is controlled by the PREFILL field in the DECFLT_x_IB register.

When the prefill control is set, the decimation filter block operates as follows:

- Input data is processed normally by the digital filter and tap values are updated.
- The decimation counter is maintained in reset value.
- The output buffer is not updated and no output interrupt is generated.
- The accompanying timestamp for the identified prefill conversion data is not bypassed.
- The overflow detector/flag operates normally and the error interrupt request is set if enabled.

28.3.5 Timestamp Data Transmission

28.3.5.1 Timestamp Data

When the selected input source is the eQADC, the eQADC can be configured to send timestamp data after related sample data for filtering. The timestamp is sent back to the RFIFO following the respective filter output, using the same mechanism. Since the Decimation Filter takes several clock cycles to process a sample, the timestamp is copied into an internal timestamp register until the filtered output is sent out, therefore freeing the input buffer for more sample data.

Timestamp information is not supported when the input data source is the CPU or DMA.

28.3.5.2 Timestamp Management

The timestamp data input is automatically sent to the Decimation Filter by the eQADC when configured to do so in the eQADC conversion command word. However, some additional conditions are considered:

- The timestamp is additional information that accompanies a sample conversion data. The eQADC block sends the decimation filter the conversion data with control bits for either prefill or filter operation. This data may optionally be followed by the corresponding timestamp data. When the corresponding conversion data is marked for prefill, the timestamp data is not sent to the output buffer. This occurs because the filter result is not sent to the output buffer.
- Similarly, when the filter is decimating the results, the timestamp is only sent to the output buffer if the corresponding received conversion data has generated a filter output that is selected by the decimation counter to be sent to the output buffer. Other received timestamps that come with data not selected by the decimator are discarded.

28.3.6 Flush Command

The flush signal is used by the Decimation Filter to execute a partial reset of the filter. This is useful when the same filter is used on a new set of data samples after finishing the filtering of another set of data.

When the flush control is detected, all filter TAPs are cleared and the DEC_COUNTER[3:0] field in the status register DECFILT_x_MSR is reset.

The flush function does not clear the Coefficient registers (DECFILT_x_COEFn) in the Decimation Filter, thus it is not required to re-write these registers after a flush. The output buffer also keeps the last result and may be retrieved until the next output is posted.

The flush control precedes the input data to be filtered. Therefore, the corresponding sample data is processed by the block after the flush. When input is from an eQADC (DECFILT_x_MCR[IO_SEL[1]] = 0), the flush command is included in the eQADC conversion command word. See [Section 28.4.1, eQADC Configuration for Decimation Filter Operation](#) for more information on an eQADC configuration of decimation filter functionality. When input is from the CPU/DMA (DECFILT_x_MCR[IO_SEL[1]] = 1), the flush command comes from the FLUSH bit in the DECFILT_x_IB register. Note that a word of valid sample data can be available at the same time the flush signal is asserted. In this case the flush is executed and the sample is processed after the flush.

The flush command is ignored when the Decimation Filter is disabled (DECFILT_x_MCR[MDIS]=1).

28.3.7 Soft Reset Command

The Soft Reset command is requested through the self negated bit SRES of the DECFILT_x_MCR register and provides the CPU with the capability to initialize the Decimation Filter. After the software reset is issued, all internal Filter TAP registers, the decimation counter, and the state machine are put in to the reset state. The status register DECFILT_x_MSR is also cleared. The Coefficient registers are not affected by the Soft Reset. If the filter is currently processing data (the MAC is active and DECFILT_x_MSR[BSY]=1), the processing is aborted. In addition, any pending output data transfer to the eQADC RFIFO is terminated. The software reset command has precedence over all other register control bits except the module disable bit. The DECFILT_x_MSR[BSY] is set on the detection of the assertion of the DECFILT_x_MCR[SRES] bit, and remains set until the reset procedure is complete.

The configuration register DECFILT_x_MCR is also not affected by a soft reset, except for the self-negation of the SRES bit.

When in debug or freeze mode, the soft reset is executed but the filter remains in debug or freeze mode.

28.3.8 Freeze Mode

The freeze mode operation is entered using the FREN and FRZ bits in the DECFILT_x_MCR register, or when the entire SoC enters debug mode.

It is not possible to enter freeze mode when the Decimation Filter is disabled.

In case of a freeze mode request during the processing of an input sample, the current processing is finished and then the Decimation Filter block enters freeze mode.

Access to all memory mapped registers in the Decimation Filter remains active in freeze mode.

28.3.9 Filter Implementation

The filter hardware shown in [Figure 28-15](#) contains eight taps which may be configured as an IIR or FIR filter. Multiplexer A controls the *bypass* filter path and multiplexer B controls/selects the filter mode of operation, to either IIR mode or FIR mode. The selection is controlled by the FTYPE[1:0] bits in the Filter Module Configuration register. The order of the filter can be controlled by setting the appropriate filter coefficients to zero. The IIR can be up to 4rd order and the FIR up to 8th order.

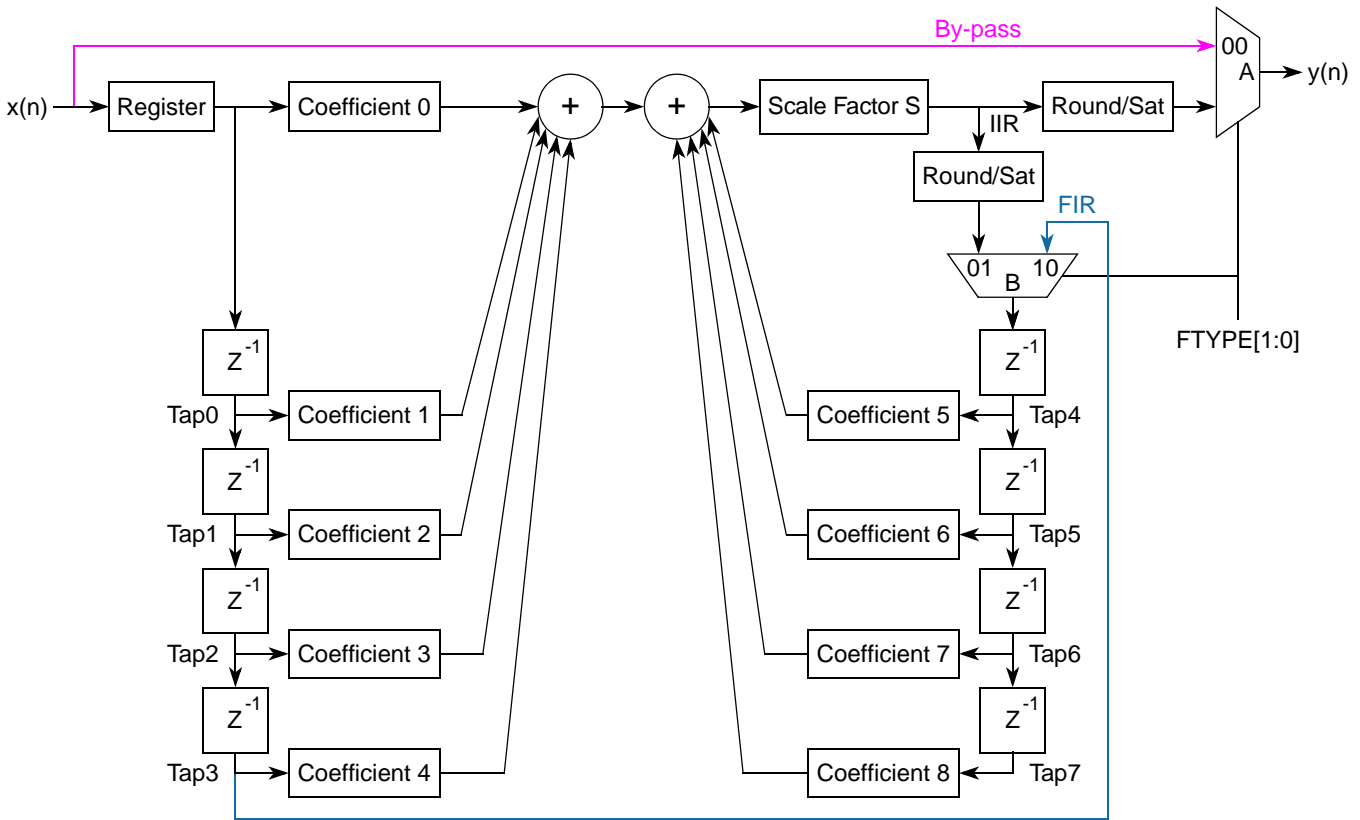

Figure 28-15. Filter Configuration Paths (FIR or 1x4Poles IIR)

28.3.10 Rounding

The Decimation Filter performs rounding operations in two different locations, as shown in [Figure 28-15](#):

- to obtain the filter output result with 16 bits
- to obtain the IIR feedback result to be stored in tap4 registers with 24 bits

The rounding mechanism implements the Convergent Rounding methodology (also known as round-to-nearest even number), which makes the decision on rounding up or down based on the value of the lower portion of data to be rounded (LS_WORD). The rounding up/down condition is equal to the traditional rounding except when the LS_WORD has the format {1000...00}. In this particular case, the rounding procedure is like the example of [Figure 28-16](#). If the MS_WORD is odd, the value is rounded up. Otherwise the value is rounded down.

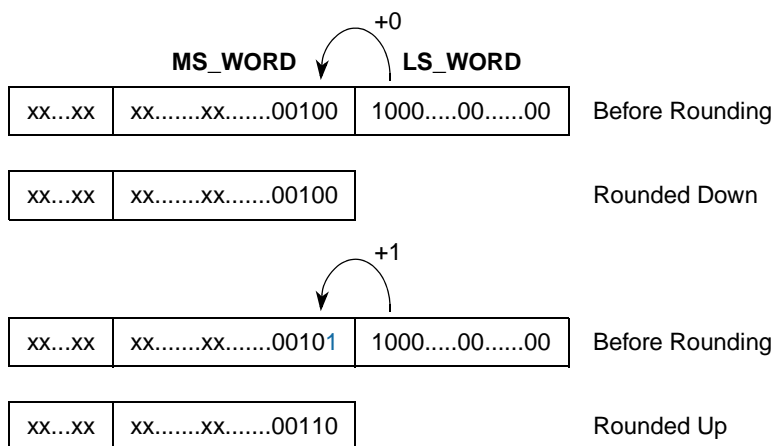

Figure 28-16. Convergent Rounding Methodology

28.3.11 Saturation

Filter output saturation occurs when an overflow or underflow condition of the filter is detected by dedicated logic, and if it is enabled by the SAT control bit of the configuration register DECFILT_x_MCR. In this condition, the filter output is set to a saturated value equal to the maximum or minimum value that can be represented by the 16-bit output port. Also, for the IIR filter an equivalent logic is used to assert the saturation for the 24-bit feedback result.

28.3.12 Interrupts and DMA Overview

There are several host request events that can be enabled using the module configuration register (MCR). An interrupt request can be issued under any of the following conditions:

- when a word of input data is received
- when the input buffer can receive data
- when a word of output data is available
- when an error has occurred.

The input data flag DECFILT_x_MSR[IDF] is set when a new input data is received from the CPU or an eQADC. Note that this flag is not used to generate read or write requests (as defined in [Section 28.3.12.1, Input Buffer Interrupt and DMA Requests](#)).

Output data is available and its flag (DECFILT_x_MSR[ODF]) is set when the input data sample is processed by the filter, the decimation counter matches the decimation rate value, and it is moved to the output buffer. It is not used to generate read requests (as defined in [Section 28.3.12.2, Output Buffer Interrupt and DMA Requests](#)).

An error event in the decimation filter block is defined as one of these events:

- Overflow in the filter, flagged by DECFILT_x_MSR[OVF]
- Overrun in the decimation filter input, flagged by DECFILT_x_MSR[IVR]
- Overrun in the decimation filter output, flagged by DECFILT_x_MSR[OVR]

- Overrun in enhanced debug monitor, flagged by DECFILT_x_MSR[DIVR]
- Integrator overrun, flagged by DECFILT_x_MSR[SVR]
- Integrator value exception, flagged by DECFILT_x_MSR[SSE]
- Integrator count exception, flagged by DECFILT_x_MSR[SCE]

A filter overflow occurs when the two's-complement result value from the MAC accumulator is out of the range of values that can be stored in tap register 4 (IIR) or in the output register.

An input overrun occurs when the input buffer is holding a word of input data and one more word of data is received by the filter. See [Section 28.3.1.1, Input Buffer Overrun](#), for more details.

An output overrun occurs when a new word of data is sent to the output buffer but the previous word of data has not been handled yet. See [Section 28.3.2.1, Output Buffer Overrun](#), for more details.

These flags can be set for input from or output to an eQADC, however they are only cleared by

- the CPU, or
- by the soft reset command (DECFILT_x_MCR[SRES])
- by the clear flag bits in the DECFILT_x_MSR register.

The DMA function for integrator result, input and output buffers is enabled setting the DECFILT_x_MCR[DSEL] = 1. The DMA request generally replaces the interrupt request that is normally generated by these registers/conditions and is discussed in more detail in [Section 28.3.12.1.3, Input Buffer DMA Request](#), [Section 28.3.12.2.2, Output Buffer DMA Request](#), and [Section 28.3.12.3, Integrator Interrupt and DMA Requests](#).

28.3.12.1 Input Buffer Interrupt and DMA Requests

28.3.12.1.1 Input Buffer Interrupt

This interrupt is enabled by the DECFILT_x_MCR[IBIE] bit and is asserted only when DECFILT_x_MCR[DSEL] = 0. If DECFILT_x_MCR[DSEL] = 1, a DMA request is generated instead (See [Section 28.3.12.1.3, Input Buffer DMA Request](#)). When this request is asserted, the DECFILT_x_MSR[IBIF] bit is set to indicate a pending interrupt.

When the input data source is the CPU, the input buffer interrupt request is asserted when the input buffer is empty, meaning the block is requesting data be written into the input buffer. The interrupt request is cleared when the CPU writes a one to the DECFILT_x_MSR[IBIC] bit, or by a soft reset command.

28.3.12.1.2 Input Buffer Enhanced Debug Monitor Interrupt

When the input data source is an eQADC, DMA is disabled, and enhanced debug is enabled, the input sample data can be read by the CPU when this interrupt request is asserted. The interrupt is asserted when a new word of sample data is supplied to the filter, and gives the application visibility into the input data being from an eQADC.

In enhanced debug mode, if the input buffer is overwritten by the next word of sample data, an input read overrun event can occur (the DECFILT_x_MSR[DIVR] bit is asserted) if the interrupt request is not cleared before, or at the same time as, the new sample arrives to set the interrupt. The

DECFLT_x_MSR[DIVR] bit is cleared by writing a one to the DECFLT_x_MSR[DIVRC] bit. Note however, in enhanced debug mode, the set condition has higher priority than the clear. This means that if the set condition occurs at the same time the CPU writes the clear bit (DECFLT_x_MSR[IBIC] to clear the interrupt, the interrupt remains asserted.

28.3.12.1.3 Input Buffer DMA Request

This DMA request is enabled by setting the IO_SEL field and the DSEL bit in the DECFLT_x_MCR register. When CPU/DMA is selected as the input data source, the input buffer DMA request is asserted when the input buffer is available to receive a conversion sample (it is not holding a word of data). This DMA request is cleared when an input data word is written to the input buffer. Therefore, the DMA request is always cleared before it is asserted again. This DMA request can also be cleared by a soft reset.

28.3.12.1.4 Input Buffer Enhanced Debug Monitor DMA Request

When an eQADC is the input data source, DMA is enabled, and enhanced debug is enabled, the input sample data can be read by DMA when this DMA request is asserted. The request is asserted when a new word of sample data is written into the input buffer to be processed. As this filter register is overwritten by the next word of sample data, a DMA read overrun event can occur (the DECFLT_x_MSR[DIVR] bit is asserted) if the DMA request is not cleared before, or at the same time as, a new sample arrives to set the DMA request. The DECFLT_x_MSR[DIVR] bit is cleared by writing one to the DECFLT_x_MSR[DIVRC] bit or by soft reset.

28.3.12.2 Output Buffer Interrupt and DMA Requests

28.3.12.2.1 Output Buffer Interrupt

This interrupt is enabled by setting the DECFLT_x_MCR[OBIE] bit, and is asserted when the output buffer is updated, CPU is selected for the output destination, and DMA is disabled. The DECFLT_x_MSR[OBIF] flag bit is set when the interrupt request is asserted.

The output buffer interrupt request can also be asserted when DECFLT_x_MCR[SDIE] = 1, and an integrator result is ready to be read. This condition is indicated when the DECFLT_x_MXSR[SDF] bit is set. Note that both the filter output and integrator output share the same interrupt source.

This interrupt request is cleared by writing a 1 to the bit DECFLT_x_MSR[OBIC] and/or the DECFLT_x_MXSR[SDFC] bits, or by a soft reset command.

28.3.12.2.2 Output Buffer DMA Request

When the CPU is selected as the output destination, and DMA is enabled, the output buffer can be read using DMA. The output buffer DMA request is asserted when the output buffer receives a new result from the filter. This DMA request is cleared when the output buffer is read by the processor, or a soft reset occurs.

28.3.12.3 Integrator Interrupt and DMA Requests

An interrupt or DMA request can be asserted when an integrator output is ready to be read or an overflow or error condition occurs in either the integrator sum or count values. Integrator interrupt requests are enabled by the `DECFLT_x_MCR[SDIE]` bit, and flagged in the `DECFLT_x_MXSR[SDF]` bit. Integrator DMA requests are enabled by the `DECFLT_x_MXCR[SDMAE]` bit.

28.3.13 Integrator

The decimation filter output result may be optionally routed to a dedicated hardware integrator. The integrator may be operated in a windowed mode, controlled by signals routed internally from eTPU2 channels, or operated in a continuous mode. Additionally, the integrator output may be configured to saturate at the maximum value of the supported range, or permitted to continue integration. Figure 28-17 shows the high level data flows and controls for the integrator. The RFIFO and Output Buffer data paths are shown in this figure to highlight that they are independent of the integrator. Note however that the Output Buffer shares a DMA and Interrupt request with the Integrator output value, `FINTVAL` (`DECFILTER_FINTVAL`).

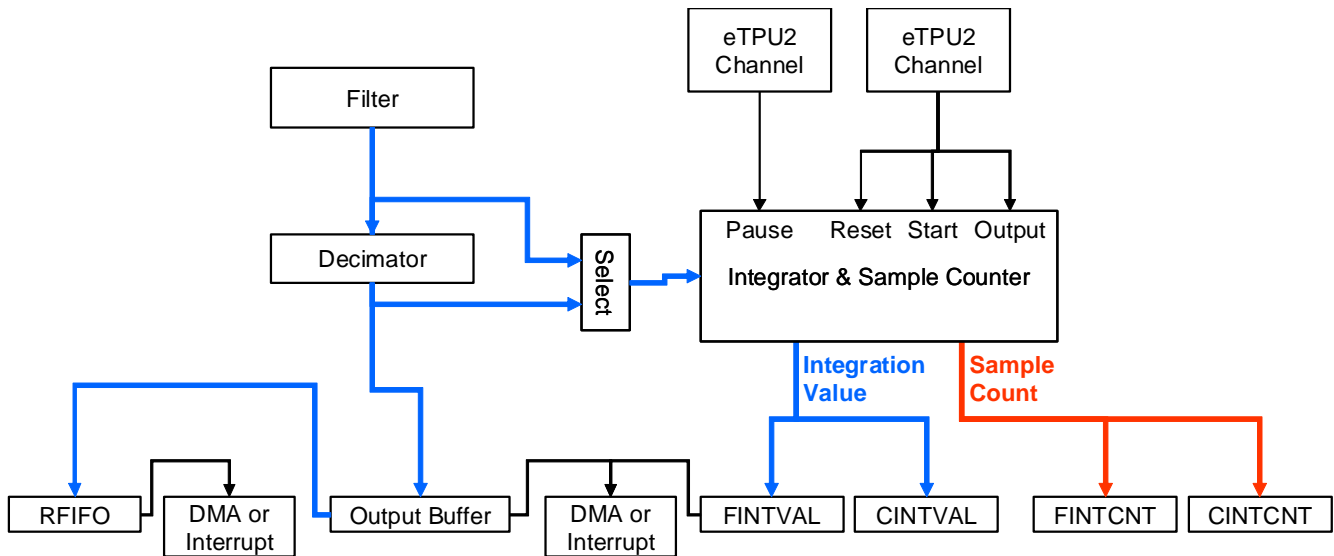

Figure 28-17. Integrator Data and Control

28.3.13.1 Integrator Inputs

The integrator input can come either directly from the filter output or from the decimator output, selected by the `DECFILTER_MXCR[SISEL]` (see Section 28.2.2.3, [Decimation Filter Module Extended Configuration Register \(DECFLT_x_MXCR\)](#)). Prior to integration a hardware option, controlled by `DECFILTER_MXCR[SSIG]`, is provided to convert the input to its absolute value.

NOTE

The integrator accumulates input samples when bypass is selected in the filter.

28.3.13.2 Integrator Output

The integrator output is provided in two separate 32 bit registers: `DECFILTER_FINTVAL` and `DECFILTER_CINTVAL`. `DECFILTER_FINTVAL` is only updated when an output request is made by an eTPU2 channel or by a core or DMA access to a configuration register. `DECFILTER_CINTVAL` is updated whenever a new integration result is available or when a reset request is made by hardware or software. The output is in one of two forms:

- the 32-bit, fixed point unsigned accumulation of the absolute values from the filter output, when configured for absolute operation (`DECFILTER_MXCR[SSIG] = 0`). This allows a total of 131071 samples to be integrated before an overflow occurs.
- the 32-bit, fixed point signed two's complement accumulation of the signed values from the filter output, when configured for signed operation (`DECFILTER_MXCR[SSIG] = 1`). This allows a total of 65536 samples to be integrated before an overflow occurs

The fractional part of the accumulation is 15 bits wide in both forms.

An accumulation overflow is flagged in `DECFILTER_MXSR[SSOVF]` when an output request occurs. The accumulator can overflow in either of the ways described below, selected through the `DECFILTER_MXCR[SSAT]`:

- saturated accumulation (`SSAT=1`), so that an overflow results in the value of `0xFFFFFFFF` for absolute value accumulation (`SSIG=0`), or `0x7FFFFFFF` (positive) and `0x80000000` (negative) for signed accumulation (`SSIG=1`).
- non-saturated accumulation (`SSAT=0`), so that an overflow results in the modulo 2^{17} accumulation value. This operation is only allowed in absolute accumulation (`SSIG=0`).

NOTE

A non-saturated overflow that occurs before `SSOVF` is cleared is still flagged in the next output request.

The integrator output value becomes available in register `DECFILTER_FINTVAL` (see [Section 28.2.2.10, Decimation Filter Final Integration Value Register \(DECFLT_x_FINTVAL\)](#)) when an integrator output request is issued. The integrator output request can be issued in the following ways:

- by an eTPU2 channel; the enabling and selection of the signal request modes is done through the `DECFILTER_MXCR[SRQSEL]` field (see [Section 28.2.2.3, Decimation Filter Module Extended Configuration Register \(DECFLT_x_MXCR\)](#)), and the channel selection is done through the `ZSELn` fields of `SIU_DECFIL1` and `SIU_DECFIL2` and `SIU_DECFIL3` registers in the SIU module.
- by software, writing 1 to the `DECFILTER_MXCR[SRQ]`;

The integrator output request also updates the register `DECFILTER_FINTCNT`, which holds the number of samples accumulated into the register `DECFILTER_FINTVAL`. This accumulated sample counter can operate either in a saturated or “wrapped” count mode, as selected by `DECFILTER_MXCR[SCSAT]`. In both cases, a counter overflow is flagged by `DECFILTER_MXSR[SCOVF]`.

NOTE

A non-saturated overflow that occurs before an `SCOVF` clear is still flagged in the next output request.

An integrator output update can also issue a DMA or interrupt request. The interrupt and DMA requests are the same ones used for the filter output buffer (see [Section 28.3.12.2, Output Buffer Interrupt and DMA Requests](#), and [Section 28.3.12.1.3, Input Buffer DMA Request](#)). `DECFILTER_MCR[SDIE]` is used to enable integrator interrupts, and the `DECFILTER_MXCR[SDMAE]` enables the DMA integrator requests. The integrator DMA request uses the same signal as the filter output DMA request, so one must never use any configuration that allows both the integrator and filter output to make DMA requests.

Integrator output updates are flagged by `DECFILTER_MXSR[SDF]`. The integrator overrun is detected in the same way as a filter output buffer overrun, and is flagged by `DECFILTER_MXSR[SVR]`. An integrator overrun also generates an error interrupt if `DECFILTER_MCR[ERREN] = 1` (see [Section 28.3.2.1, Output Buffer Overrun](#)).

Registers `DECFILTER_CINTVAL` and `DECFILTER_CINTCNT` provide a way to poll intermediate integration values and sample counts, respectively (see [Section 28.2.2.12, Decimation Filter Current Integration Value Register \(DECFLT_x_CINTVAL\)](#), and [Section 28.2.2.13, Decimation Filter Current Integration Count Value Register \(DECFLT_x_CINTCNT\)](#)). `DECFILTER_CINTVAL` is updated whenever the integrator is reset or a new sample is accumulated. `DECFILTER_CINTCNT` is updated only when `DECFILTER_CINTVAL` is read, so that coherency between the value and count values is guaranteed. Therefore, the read access order of that pair of registers must be `DECFILTER_CINTVAL` first, followed by `DECFILTER_CINTCNT`.

NOTE

The flags `SSOVF` and `SCOVF` can also asserted when `DECFILTER_CINTVAL` is read. The `SSOVF` and `SCOVF` set and clearing rules apply for the `DECFILTER_CINTVAL` read the same way as for an integrator output request.

28.3.13.3 Integrator Reset

The integration value is reset to the value of zero, in the following ways:

- by hardware: on hardware reset, or controlled by an eTPU2 channel; the enabling and selection of the zero signal modes is done through `DECFILTER_MXCR[SZROSEL]` (see [Section 28.2.2.3, Decimation Filter Module Extended Configuration Register \(DECFLT_x_MXCR\)](#)), and eTPU2 channel selection is defined by the `ZSELn` fields of the `SIU_DECFIL1` and `SIU_DECFIL2` and `SIU_DECFIL3` registers in the SIU module.
- by software: on software reset, or writing 1 to the `DECFILTER_MXCR` bit `SZRO`;

The integrator reset also zeroes the internal counter of accumulated samples and the internal overflow state (but not `SSOVF` and `SCOVF`). Software and hardware reset resets all integrator registers immediately.

An Integrator zero command from an eTPU2 channel or by software (`SZRO`) affects the integrator registers and flags as follows:

- `DECFILTER_CINTVAL` resets immediately;
- `DECFILTER_CINTCNT` does not reset immediately; it is updated only upon a `DECFILTER_CINTVAL` read, loaded with the number of integrated samples occurred after the reset;

- DECFILTER_FINTVAL and DECFILTER_FINTCNT do not reset immediately; being updated only upon a new output request (see [Section 28.3.13.2, Integrator Output](#)); if a integrator software zero command (through SZRO bit) and an integrator output request (through SRQ bit) are made at the same time, the registers DECFILTER_FINTVAL and DECFILTER_FINTCNT are updated with the last internal values before reset; the same applies to simultaneous integrator zero command and output request by hardware signal;
- all internal overflow flags

NOTE

An integrator zero request does not negate the SSOVF and SCOVF flags

NOTE

The integrator reset does not depend on the integrator enabling (see [Section 28.3.13.4, Integrator Enabling and Halting](#)).

28.3.13.4 Integrator Enabling and Halting

Two mechanisms, enabling and halting, drive the integrator accumulation, allowing it to be controlled by a combination of two sources:

- both software
- both hardware (eTPU2 channels)
- one hardware (eTPU2 channel) and other software

Values are accumulated when the integrator is enabled and not halted. The integrator halt and enable states can be controlled in the following ways:

- by hardware, through eTPU2 channels; the enabling and the selection of the signal request modes is done through DECFILTER_MXCR[SENSEL] and DECFILTER_MXCR[SHLTSEL] fields, respectively (see [Section 28.2.2.3, Decimation Filter Module Extended Configuration Register \(DECFLT_x_MXCR\)](#)), and channel selection is done through the SIU_DECFIL1 and SIU_DECFIL2 and SIU_DECFIL3 registers in the SIU module.
- by software, through the same DECFILTER_MXCR[SENSEL] and DECFILTER_MXCR[SHLTSEL] fields. Note that these fields are in different bytes, so that two distinct, concurrent software tasks can avoid coherency problems by changing the fields using byte read-modify-write accesses.

eTPU2 selection for the integrator enable state is defined by SIU_DECFILn[ZSELn] fields.

eTPU2 selection for the integrator halt state is defined by SIU_DECFILn[HSELn] fields.

NOTE

Enabling and halting does not affect output requests or integrator reset.

28.3.13.5 Integrator Exceptions

Integrator may run into exception states due to overflow, either of the accumulated value or the sample counter. Exceptions are flagged by the DECFILTER_MXSR bits SSE, for sum value exception, and SCE,

for counter exception. These flags generate an error interrupt, if it is enabled (see [Section 28.3.12, Interrupts and DMA Overview](#)).

The accumulator exception condition depends on whether it operates in saturated mode or not, as follows:

- In Saturated operation (DECFILTER_MXCR[SSAT] = 1): a sum exception occurs (SSE=1) whenever an overflow is flagged; SSE asserts together with SSOVF.
- In Non-saturated operation (DECFILTER_MXCR[SSAT] = 0): a sum exception occurs (SSE=1) when an overflow is flagged and DECFILTER_MXSR[SSOVF] is already set to 1.
- In Non-saturated operation, an accumulator exception also occurs if the accumulator overflows twice without any update of the final integrator value DECFILTER_FINTVAL or the current integrator counter DECFILTER_CINTCNT (by a read to the DECFILTER_CINTVAL register), neither an integrator reset occurs. The SSOVF flag does not assert in this situation.

NOTE

The SSOVF flag can only be asserted upon a hardware request, a software request, or when DECFILTER_CINTVAL is read, based on the internal accumulator overflow state.

Similarly, the sample counter exception condition depends on whether it operates in saturated mode or not, as follows:

- In Saturated operation (DECFILTER_MXCR[SCSAT] = 1): a counter exception occurs (SCE=1) whenever an overflow is flagged; SCE asserts together with SCOVF.
- In Non-saturated operation (DECFILTER_MXCR[SCSAT] = 0): a counter exception occurs (SCE=1) when an overflow is flagged and the DECFILTER_MXSR bit SCOVF is already set to 1.
- In Non-saturated operation, a counter exception also occurs if the counter overflows twice without any update of the final count DECFILTER_FINTCNT or the current integrator counter DECFILTER_CINTCNT (by a read to the DECFILTER_CINTVAL register), neither an integration reset occurs. The SCOVF flag does not assert in this situation.

NOTE

The SCOVF flag can only be asserted upon a hardware request, a software request, or when DECFILTER_CINTVAL is read (also updating DECFILTER_CINTCNT), based on the internal counter overflow state.

28.3.14 Cascade Mode

Cascade mode is a configuration of the decimation filters where two or more filters are chained together serially to provide more complex filtering functions. All filters in the cascade arrangement are configured to operate in cascade mode using the CASCD[1:0] field in the DECFILT_x_MCR register. [Figure 28-18](#) shows an example of a simple cascaded arrangement. This example shows the eQADC being used for both data input and output, but cascaded filters may also be configured to receive data from the CPU/DMA. The ‘head’ receives the raw data to be filtered from the eQADC. The bottom block, or ‘tail’, is the last filter block in the chain. It sends the output result to the selected data destination. The blocks in between, or ‘middle’ blocks, do not exchange data (receive/transmit) with the eQADC (or CPU/DMA), only with the

preceding and following decimation filter blocks in the cascade. Middle blocks are optional. A minimum of two blocks, one head block feeding one tail block can be used in cascade.

NOTE

The values passed between cascaded blocks can be monitored using Enhanced Debug Monitor (see [Section 28.3.15, Enhanced Debug Monitor Description](#)).

The following are general considerations for creating and using cascaded filters:

- The block configurations as head, tail or middle must respect their physical connections such that all the following apply:
 - a ‘head’ block must feed a ‘middle’ or a ‘tail’ block
 - a ‘middle’ must feed another ‘middle’ block or a ‘tail’ block
 - a ‘tail’ feeds no other block, and its output will be either the CPU/DMA interface or the eQADC FIFOs.
 - A ‘head’ is fed by no other block. Its input is either the CPU/DMA interface or the eQADC.
 - Cascaded filters must be sequential, that is; Filter A feeds Filter B which feeds Filter C etc.
- As a consequence of the conditions above, there must be one and only one ‘head’ block and one and only one ‘tail’ block in a cascade.
- More than one group of physically chained blocks can form a cascade. For example, [Figure 28-19](#) shows two physical chains, with blocks A and B configured as head and tail, respectively, forming one cascaded filter block. Two of the remaining blocks form another cascaded filter block starting with block E (head), and ending with block F (tail).
- Blocks not used in a cascaded chain can be used normally by setting the DECFILT_x_MCR[CASCD] field to 0b00, as shown in [Section 28.3.14.1](#).
- The optional connection shown from block L to block A in [Section 28.3.14.1](#) allows block L to be configured as head or middle, feeding block A configured as middle or tail, yielding more flexibility, as in the last example of [Section 28.3.14.1](#).
- The input to a cascaded configuration is selected by the DECFILT_x_MCR[IO_SEL] bitfield of the head block. The output target of the cascaded blocks is selected by the DECFILT_x_MCR[IO_SEL] bitfield of the tail block.

28.3.14.1 Example Configurations

The following diagrams illustrate some of the possible options for using the decimation filters in a cascaded configuration. In all illustrated examples, the `DECFLT_x_MCR[IO_SEL]` bits are set to select the eQADC as the source for input conversion data, and the eQADC RFIFOs as destination for the outputs of the filter(s).

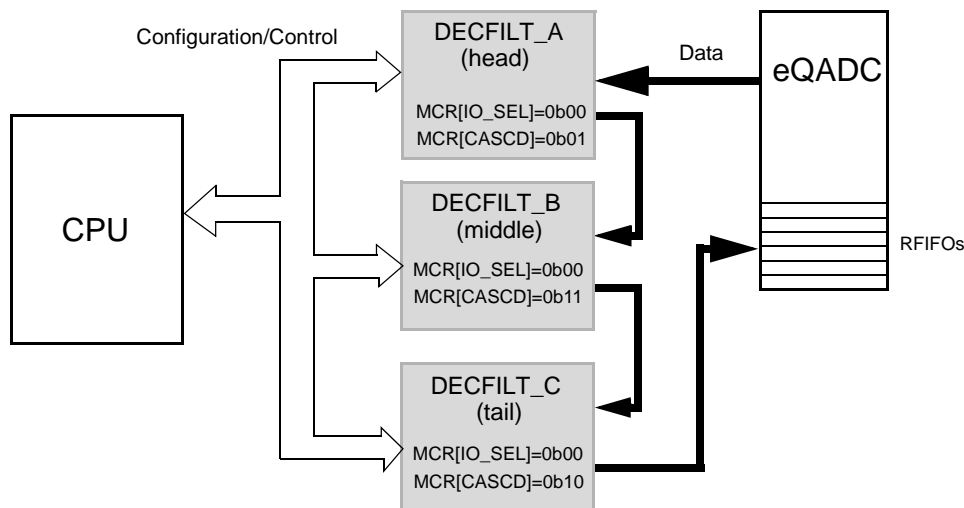

Figure 28-18. Cascaded Filters

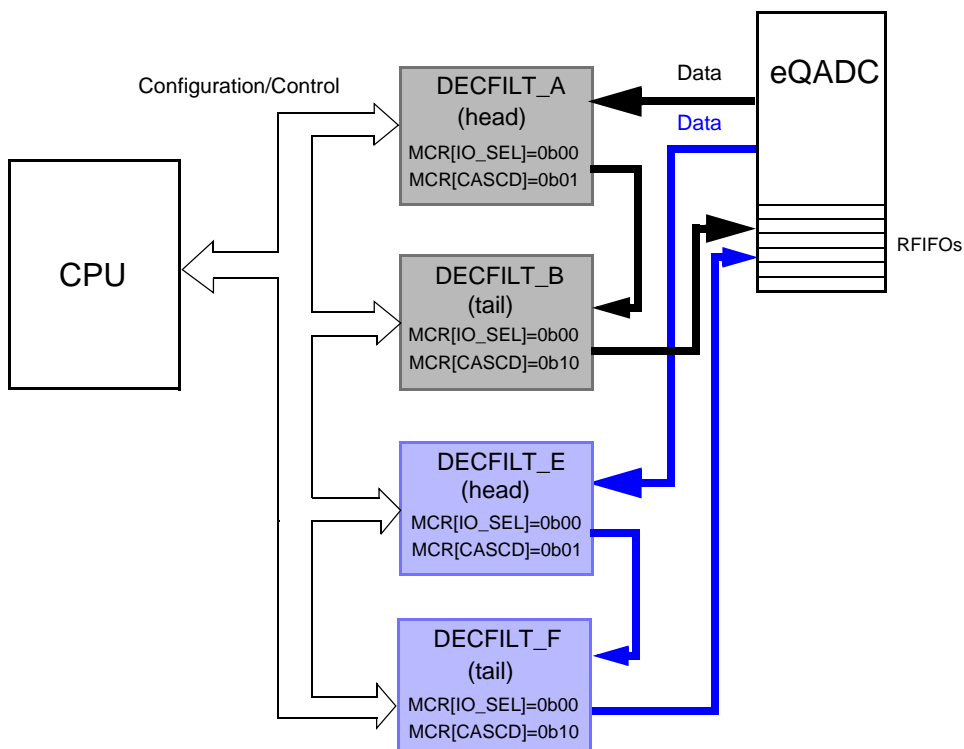

Figure 28-19. Multiple Cascaded Filters

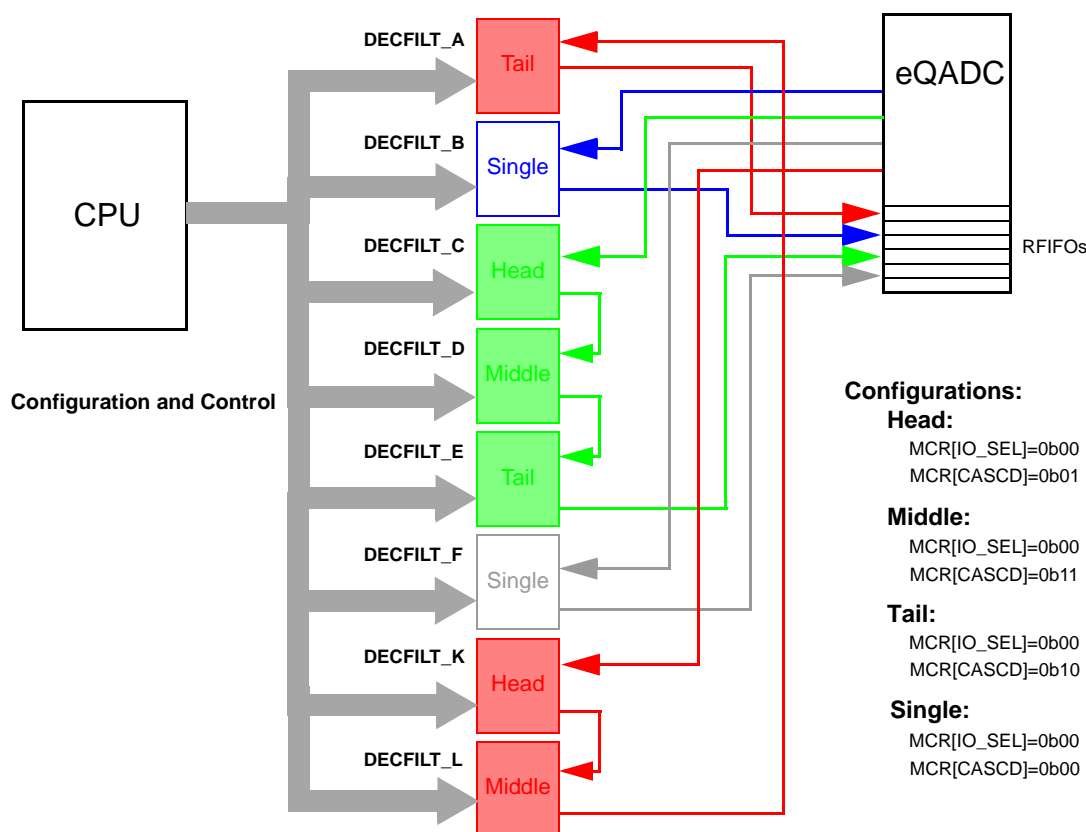

Figure 28-20. Mixed Cascaded and Single Blocks

28.3.14.2 Cascade Freeze, Stop, and Configuration Change Procedures

To change a block configuration mode to or from cascade mode, the following safe procedures must be observed:

- To modify a cascade combo, either to single or any other cascade combo combination, all the cascade combo blocks must have their inputs disabled (using DECFILT_x_MCR[IDIS]), in order, from the Head to the Tail block. After a block IDIS bit has been set to 1 (one), one must wait for its DECFILTER_x_MSR bit BSY to be 0 (zero) before disabling the input of the next block in the sequence.
- Each block in a new cascade combo must be configured with its input disabled. When the mode configuration is done, the combo blocks must have their inputs enabled in order, from the Tail towards the Head block.
- A single block must also be reconfigured the same way, to or from a cascade combo configuration: first disabling its input, and then waiting for a non-busy state before writing DECFILTER_x_MCR field CASCD.

To take cascade combo blocks to or from freeze or low power modes, a similar procedure must be used:

- Take the Head to freeze or low-power first, wait for DECFILTER_x_MSR bit BSY=0, and repeat the procedure for the other blocks in the chain in sequence, towards the Tail block.

Take the blocks out of freeze or low-power modes in the inverse sequence, from Tail to Head.

28.3.15 Enhanced Debug Monitor Description

This feature is enabled by the EDME bit in the configuration register DECFILTER_x_MCR. The monitoring operation is applicable only to an eQADC input data source, and applies when filters are cascaded. The Enhanced Debug Monitor feature makes the input sample data also available in the DECFILTER_x_EDID register. A DMA or interrupt request (selected by DECFILT_x_MCR[DSEL]) indicates a new input was fed and DECFILTER_x_EDID was updated. The input is processed normally by the filter.

An Enhanced Debug Input Data Register (DECFILTER_x_EDID) overrun can occur if a sample is not read by the CPU or DMA before overwritten by a new sample. The overrun is indicated in a separate flag DIVR in the status register DECFILTER_x_MSR. If the ERREN bit is set in the DECFILTER_x_MCR configuration register, this overrun asserts the an interrupt request.

28.4 Application Information

The following sections describe common use cases and configurations of the decimation filter block.

28.4.1 eQADC Configuration for Decimation Filter Operation

28.4.1.1 eQADC Configuration / Decimation Filter Input

In normal mode of operation of the Decimation Filter, filter data inputs are supplied by an eQADC block and the filter output is returned to the specified RFIFO in the eQADC. In standard eQADC operation, conversion results are routed directly from the converter to one of the local eQADC RFIFO buffers. However, by using alternate conversion command word configurations in the eQADC, conversion results can be routed to the Decimation Filter block. Additionally, the same eQADC conversion results can be routed to a second Decimation Filter block specified by an Extended Alternate Configuration register. The eQADC can send either conversion data or timestamp data. The conversion data is filtered by the decimation filter and the timestamp is bypassed and delayed until ready to be sent back to the eQADC when the relevant conversion data is filtered and available.

In the eQADC, the ALT_CONFIG_SEL[0:7] field of the Conversion Command Word (CCW) specifies whether an alternate configuration is used for the ADC conversion. The values for this field are given in [Table 28-17](#). The eQADC can store up to eight alternate configurations, which can be dynamically selected during the ADC conversion with the CCW. When the ALT_CONFIG_SEL field is set to 0x00, no alternate configuration is used, and the ADC conversion is processed according to the CCW.

Table 28-17. eQADC Alternate Configuration Selection

| ALT_CONFIG_SEL[0:7] | Alternate Configuration |
|---------------------|----------------------------------|
| 0x00 | Alternate Configuration Not Used |
| 0x08 | 1 |
| 0x09 | 2 |
| 0x0A | 3 |
| 0x0B | 4 |
| 0x0C | 5 |
| 0x0D | 6 |
| 0x0E | 7 |
| 0x0F | 8 |

Each eQADC alternate configuration uses the format specified in [Figure 28-21](#). The RET_INH, DEST, and FMTA bits/fields in the Alternate Configuration register pertain to Decimation Filter operation, and the RESSEL and PRE_GAIN fields do not. The RET_INH bit is used by eQADC to set the Decimation Filter in/out of prefill mode. The DEST field determines which Decimation Filter the conversion result is sent to, and the encoding is given in [Table 28-18](#). The FMTA bit determines whether the data going to the Decimation Filter is signed or unsigned.

The eight Alternate Configurations are stored in the ADC by executing write commands to the On-Chip ADC Alternate Configuration Registers. The write command is specified in the Write Configuration Command Format for On-Chip ADC Operation section of the reference manual. The Alternate Configuration register addresses 0x30 through 0x4C for each ADC0/1 converter in an eQADC are given at the top of the register diagram.

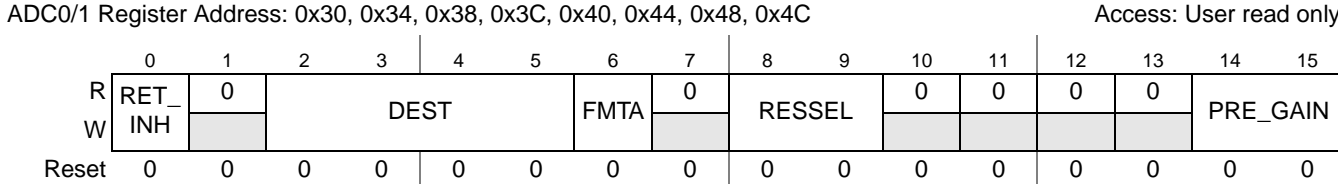

Figure 28-21. Alternate Configuration 1-8 Control Registers (ADC_ACR1-8)

28.4.1.2 eQADC Configuration / Decimator Output

Table 28-18. ADC_ACR1-8 Field Descriptions

| Field | Description | | | | | | | | | | | | | | | | | | | | | | | | | | | | | | | | | | |
|-----------|---|-----------|-------------|------|---|------|---|------|---|------|---|------|---|------|---|------|---|------|---|------|--|------|--|------|--|------|--|------|--|------|--|------|--|------|--|
| RET_INH | <p>Result Transfer Inhibit / Decimation Filter Pre-Fill—This bit is used to inhibit the transfer of the result data from the peripheral module to the result queue. When the module is a Decimation Filter, this bit sets the filter in a special mode (PRE-FILL) in which it does not generate decimated samples out from the conversion results received from the EQADC block, but the conversion samples are used by the filter algorithm. This feature allows a proper initialization of the Decimation Filter without generating any decimated result. Or this bit is useful for sending the result of the ADC to the STAC bus master but not putting the result in the result queue.</p> <p>0 Result transfer to result queue / Decimation Filter in filtering mode 1 No result transfer to result queue / Decimation Filter PRE-FILL mode</p> | | | | | | | | | | | | | | | | | | | | | | | | | | | | | | | | | | |
| DEST[0:3] | <p>Conversion Result Destination Selection—The DEST[0:3] field selects the Decimation Filter destinations of the conversion result generated by the Alternate Conversion Command. This field also affects the behavior of the FMTA bit and the FFMT bit of the conversion command for alternate configurations (see Conversion Command Format for Alternate Configurations).</p> <table border="1" style="margin-left: auto; margin-right: auto;"> <thead> <tr> <th>DEST[0:3]</th> <th>Description</th> </tr> </thead> <tbody> <tr> <td>0000</td> <td>The conversion result is sent to the RFIFOs. The data format is specified by the FFMT bit in the conversion command.</td> </tr> <tr> <td>0001</td> <td>The conversion result is sent to Decimation Filter block A.</td> </tr> <tr> <td>0010</td> <td>The conversion result is sent to Decimation Filter block B.</td> </tr> <tr> <td>0011</td> <td>The conversion result is sent to Decimation Filter block C.</td> </tr> <tr> <td>0100</td> <td>The conversion result is sent to Decimation Filter block D.</td> </tr> <tr> <td>0101</td> <td>The conversion result is sent to Decimation Filter block E.</td> </tr> <tr> <td>0110</td> <td>The conversion result is sent to Decimation Filter block F.</td> </tr> <tr> <td>0111</td> <td>The conversion result is sent to Decimation Filter block G.</td> </tr> <tr> <td>1000</td> <td>The conversion result is sent to Decimation Filter blocks A and E.</td> </tr> <tr> <td>1001</td> <td>The conversion result is sent to Decimation Filter blocks B and E.</td> </tr> <tr> <td>1010</td> <td>The conversion result is sent to Decimation Filter blocks C and E.</td> </tr> <tr> <td>1011</td> <td>The conversion result is sent to Decimation Filter blocks D and E.</td> </tr> <tr> <td>1100</td> <td>The conversion result is sent to Decimation Filter blocks A and G.</td> </tr> <tr> <td>1101</td> <td>The conversion result is sent to Decimation Filter blocks B and G.</td> </tr> <tr> <td>1110</td> <td>The conversion result is sent to Decimation Filter blocks C and G.</td> </tr> <tr> <td>1111</td> <td>The conversion result is sent to Decimation Filter blocks D and G.</td> </tr> </tbody> </table> | DEST[0:3] | Description | 0000 | The conversion result is sent to the RFIFOs. The data format is specified by the FFMT bit in the conversion command. | 0001 | The conversion result is sent to Decimation Filter block A. | 0010 | The conversion result is sent to Decimation Filter block B. | 0011 | The conversion result is sent to Decimation Filter block C. | 0100 | The conversion result is sent to Decimation Filter block D. | 0101 | The conversion result is sent to Decimation Filter block E. | 0110 | The conversion result is sent to Decimation Filter block F. | 0111 | The conversion result is sent to Decimation Filter block G. | 1000 | The conversion result is sent to Decimation Filter blocks A and E. | 1001 | The conversion result is sent to Decimation Filter blocks B and E. | 1010 | The conversion result is sent to Decimation Filter blocks C and E. | 1011 | The conversion result is sent to Decimation Filter blocks D and E. | 1100 | The conversion result is sent to Decimation Filter blocks A and G. | 1101 | The conversion result is sent to Decimation Filter blocks B and G. | 1110 | The conversion result is sent to Decimation Filter blocks C and G. | 1111 | The conversion result is sent to Decimation Filter blocks D and G. |
| DEST[0:3] | Description | | | | | | | | | | | | | | | | | | | | | | | | | | | | | | | | | | |
| 0000 | The conversion result is sent to the RFIFOs. The data format is specified by the FFMT bit in the conversion command. | | | | | | | | | | | | | | | | | | | | | | | | | | | | | | | | | | |
| 0001 | The conversion result is sent to Decimation Filter block A. | | | | | | | | | | | | | | | | | | | | | | | | | | | | | | | | | | |
| 0010 | The conversion result is sent to Decimation Filter block B. | | | | | | | | | | | | | | | | | | | | | | | | | | | | | | | | | | |
| 0011 | The conversion result is sent to Decimation Filter block C. | | | | | | | | | | | | | | | | | | | | | | | | | | | | | | | | | | |
| 0100 | The conversion result is sent to Decimation Filter block D. | | | | | | | | | | | | | | | | | | | | | | | | | | | | | | | | | | |
| 0101 | The conversion result is sent to Decimation Filter block E. | | | | | | | | | | | | | | | | | | | | | | | | | | | | | | | | | | |
| 0110 | The conversion result is sent to Decimation Filter block F. | | | | | | | | | | | | | | | | | | | | | | | | | | | | | | | | | | |
| 0111 | The conversion result is sent to Decimation Filter block G. | | | | | | | | | | | | | | | | | | | | | | | | | | | | | | | | | | |
| 1000 | The conversion result is sent to Decimation Filter blocks A and E. | | | | | | | | | | | | | | | | | | | | | | | | | | | | | | | | | | |
| 1001 | The conversion result is sent to Decimation Filter blocks B and E. | | | | | | | | | | | | | | | | | | | | | | | | | | | | | | | | | | |
| 1010 | The conversion result is sent to Decimation Filter blocks C and E. | | | | | | | | | | | | | | | | | | | | | | | | | | | | | | | | | | |
| 1011 | The conversion result is sent to Decimation Filter blocks D and E. | | | | | | | | | | | | | | | | | | | | | | | | | | | | | | | | | | |
| 1100 | The conversion result is sent to Decimation Filter blocks A and G. | | | | | | | | | | | | | | | | | | | | | | | | | | | | | | | | | | |
| 1101 | The conversion result is sent to Decimation Filter blocks B and G. | | | | | | | | | | | | | | | | | | | | | | | | | | | | | | | | | | |
| 1110 | The conversion result is sent to Decimation Filter blocks C and G. | | | | | | | | | | | | | | | | | | | | | | | | | | | | | | | | | | |
| 1111 | The conversion result is sent to Decimation Filter blocks D and G. | | | | | | | | | | | | | | | | | | | | | | | | | | | | | | | | | | |
| FMTA | <p>Conversion Data Format for Alternate Configuration—If the DEST field is not 0b000, the FMTA bit specifies how the 12-bit conversion data returned by the ADCs is formatted into the 16-bit data which is sent to the parallel side interface.</p> <p>0 Right justified unsigned 1 Right justified signed</p> | | | | | | | | | | | | | | | | | | | | | | | | | | | | | | | | | | |

Table 28-18. ADC_ACR1-8 Field Descriptions (continued)

| Field | Description |
|---------------|---|
| RESSEL[0:1] | ADC Resolution Selection. 00 ADC set to 12-bits resolution 01 ADC set to 10-bits resolution 10 ADC set to 8-bits resolution 11 Reserved |
| PRE_GAIN[0:1] | ADC Pre-gain control—The PRE_GAIN[0:1] controls the gain of the ADC input stage by changing the internal ADC iterations in the gain stage. 00 X1 gain 01 X2 gain 10 X4 gain 11 Reserved |

The RFIFO number that receives the filtered data from the Decimation Filter block, or directly from the ADC, is specified in the MESSAGE_TAG[8:11] field in the eQADC CCW (see “Conversion Command Format for the Standard Configuration section of the reference manual).

28.5 Use Cases

The following use cases provide examples of how to configure the decimation filter for different modes. One use case describes the mode that filters the conversion results that directly transferred from the ADC. In this case, the appropriate software initialization of the ADC configuration register is described to enable the transfer of an ADC result to the Decimation Filter module without CPU intervention. The second use cases describes the stand-alone mode, where data previously stored in a memory table is transferred into the filter and subsequent filtered data extracted using CPU interaction. For all uses cases, the Decimation Filter is configured as an IIR filter, with example filter characteristics. An explanation of the IIR configuration and coefficient selection is give in the next section.

28.5.1 IIR Filter Configuration

This section describes the topology of the IIR filter that is implemented in the Decimation Filter hardware and provides a definition of the coefficients for an elliptical low pass, 4th order IIR filter. [Figure 28-22](#) shows the filter functional diagram, consisting of 4 feed-forward stages and 4 feedback stages, to provide a maximum of a 4th order IIR filter.

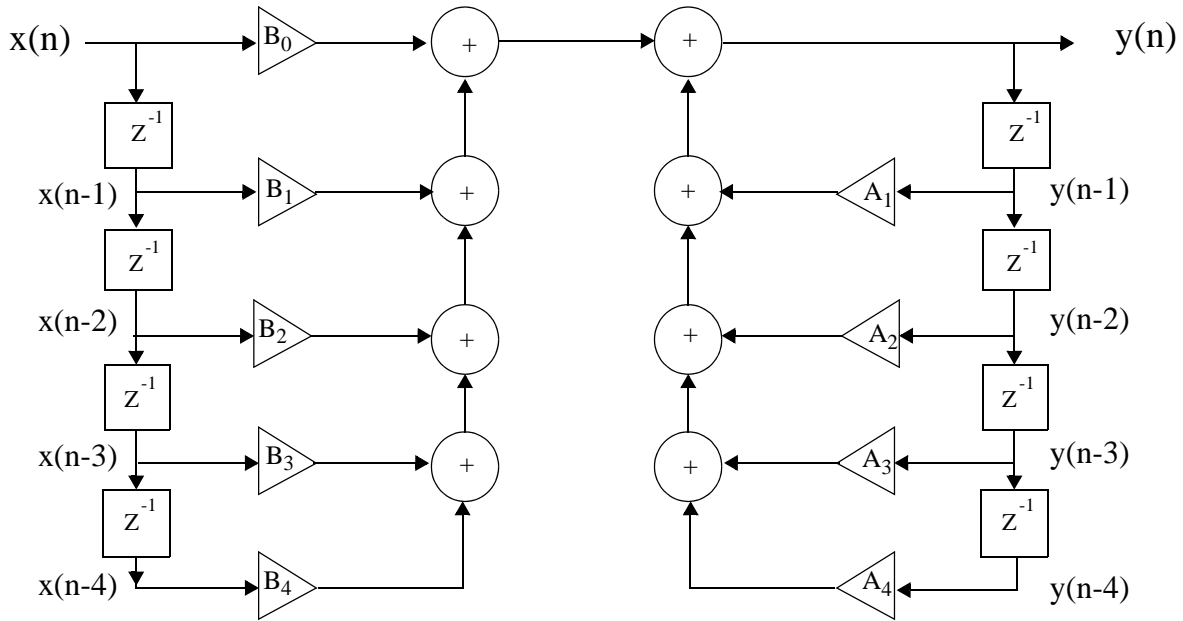

Figure 28-22. 1 x 4 Poles IIR Filter Functional Diagram

The generalized difference equation for the IIR filter of Figure 28-22 can be written as:

Eqn. 28-1

$$y(n) = \sum_{i=0}^N B_i x(n-i) + \sum_{j=1}^M A_j y(n-j)$$

where $x(n)$ is the filter input at time n , $y(n)$ is the filter output at time n , N is the number of feed-forward filter coefficients minus one, B_i are the feed-forward filter coefficients, M is the number of feed-back filter coefficients, and A_j are the feedback filter coefficients.

In order to optimize the hardware implementation, the coefficients must be scaled to a maximum range of +1 to -1. Taking scaling into account, Equation 28-1 can be expressed as:

Eqn. 28-2

$$y(n) = S \left\{ \sum_{i=0}^N \frac{B_i}{S} x(n-i) + \sum_{j=1}^M \frac{A_j}{S} y(n-j) \right\}$$

All coefficients are scaled down by S , and the output of the accumulator is multiplied by S .

The block diagram shown in [Figure 28-23](#) represents the hardware implementation of the Decimation Filter, which includes the scale factor hardware that compensates for the scaling of the coefficients. The scale factor, S , is set by the bit field `DECFILT_x_MCR[SCAL]`.

Coefficients B_0 to B_4 correspond to `DECFILT_x_COEF0` to `DECFILT_x_COEF4`

Coefficients A_1 to A_4 correspond to `DECFILT_x_COEF5` to `DECFILT_x_COEF8`.

The delay taps labelled Tap0 to Tap7 correspond to the memory mapped registers `DECFILT_x_TAP0` to `DECFILT_x_TAP7`.

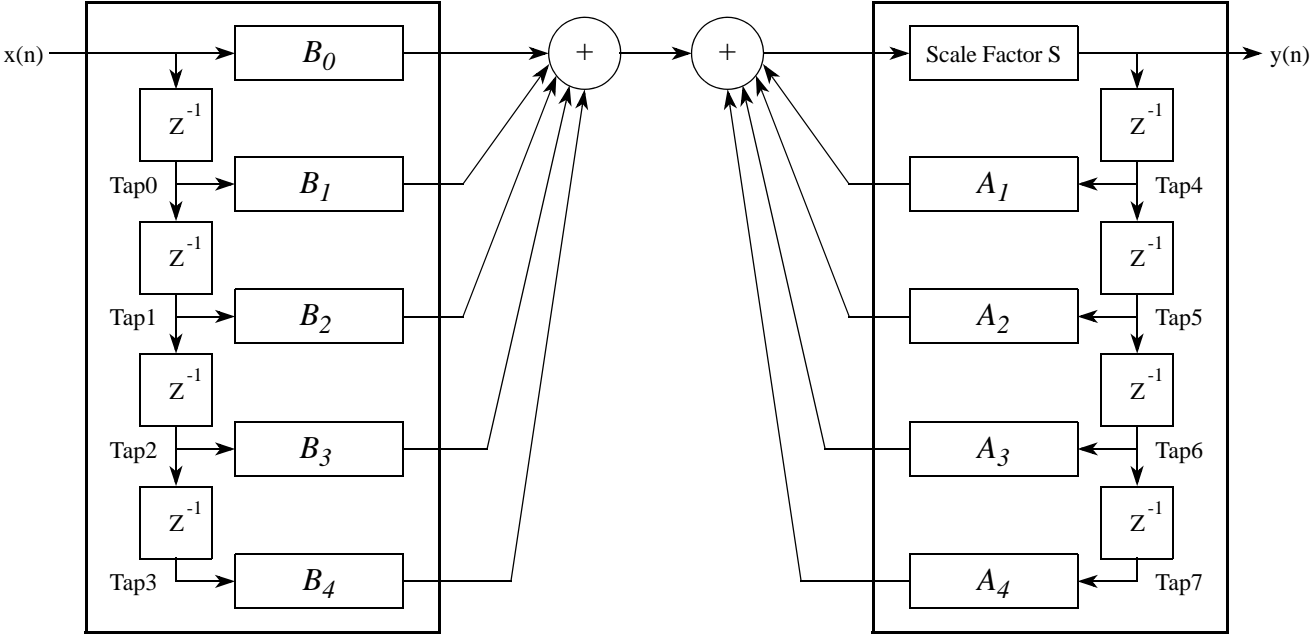

Figure 28-23. Fourth Order IIR Filter Implementation Block Diagram

The examples given here implement a filter with the following characteristics:

- Filter type: elliptic/low pass IIR
- Filter order: 4th order
- Input sample rate: 800k sample/s
- Passband edge: 100 kHz
- Stopband edge: 150 kHz
- Passband attenuation: ≤ 1 dB

[Table 28-19](#) lists the computed coefficients, in real number notation, to achieve the above characteristics.

Table 28-19. Computed Coefficient Values

| Coefficient | Decimal Value | Coefficient | Decimal Value |
|-------------|---------------------|-------------|-------------------|
| B0 | 0.0221455 | A0 | -1.0 |
| B1 | 0.00445582948893748 | A1 | 2.69772868375858 |
| B2 | 0.0318517846509088 | A2 | -3.234056294853 |
| B3 | 0.00445582948893748 | A3 | 1.92028561712454 |
| B4 | 0.0221455 | A4 | -0.47939080709495 |

Since the number range of the computed coefficients exceeds the range of the hardware, the coefficients must be scaled, by at least a factor of 4. In this example, a factor of 8 is chosen. [Table 28-20](#) below lists the scaled values and their 24 bit signed fractional values, in hexadecimal notation.

Table 28-20. Coefficient Values for Decimation Filter

| Filter Coefficients | Computed Value | Scaled Value (SCAL=8) | |
|--------------------------|---------------------|-----------------------|------------------------------|
| | Decimal Value | Decimal Value | Hexadecimal Values (24 bits) |
| DECFLT_x_COEF0 = B0/SCAL | 0.0221455 | 0.00276815891266 | 0x005AB5 |
| DECFLT_x_COEF1 = B1/SCAL | 0.00445582948893748 | 0.00055694580078 | 0x001240 |
| DECFLT_x_COEF2 = B2/SCAL | 0.0318517846509088 | 0.00398147106171 | 0x008277 |
| DECFLT_x_COEF3 = B3/SCAL | 0.00445582948893748 | 0.00055694580078 | 0x001240 |
| DECFLT_x_COEF4 = B4/SCAL | 0.0221455 | 0.00276815891266 | 0x005AB5 |
| DECFLT_x_COEF5 = A1/SCAL | 2.69772868375858 | 0.33721613883972 | 0x2B29E6 |
| DECFLT_x_COEF6 = A2/SCAL | -3.234056294853 | -0.40425717830658 | 0xCC414E |
| DECFLT_x_COEF7 = A3/SCAL | 1.92028561712454 | 0.24003565311432 | 0x1EB97D |
| DECFLT_x_COEF8 = A4/SCAL | -0.47939080709495 | -0.05992400646210 | 0xF8546A |

28.5.2 Initialization Procedure

Specific initialization for two different operating modes is provided in the use case sections that follow this section. The general sequence of steps for initializing one Decimation Filter is:

1. Program the configuration registers `DECFLT_x_MCR` to configure the input data source and output result destination.
2. Write all filter coefficient registers `DECFLT_x_COEFn` with values that define the filter frequency response characteristics.
3. Execute a soft reset if the filter was previously configured, by writing `DECFLT_x_MCR[SRES] = 1`.

4. The module is ready to receive data and perform a filtering function.
5. If the input data source is an eQADC, these additional steps must be executed:
 - a) Configure and enable the eQADC converter to transfer results to the filter.
 - b) Configure and enable the eQADC commands to transfer filtered results to desired RFIFO.
 - c) Configure and enable a DMA channel or CPU interrupt handler to transfer result from RFIFO to memory.
6. If the input data source is the CPU/DMA, configure a CPU interrupt handler or polling software to input unfiltered data and retrieve the filter data.

28.5.2.1 Use Case 1 - Normal mode, ADC conversion and filtering.

The input to Filter A is from an ADC conversion result.

Filter A is configured as a 4rd order low pass IIR.

The output from the filter is routed to RFIFO5 and transferred to memory by the DMA.

Decimation is not enabled.

Saturation is enabled.

28.5.2.1.1 DECFILT_A_MCR — Module Configuration Register settings

Enable IIR Filter type: FTYPE=1

Scale coefficients to a range of +1 to -1: SCAL=8

Enable saturation of filter output result: SAT=1

Select 'normal' mode, to transfer data from ADC through filter, to RFIFO: IO_SEL[1]=0

Select no decimation: DEC_RATE=0

28.5.2.1.2 DECFILT_A_COEFn

Write the filter coefficients given in [Table 28-20](#) to the following registers.

DECFILT_A_COEF0 = 0x005AB5

DECFILT_A_COEF1 = 0x001240

DECFILT_A_COEF2 = 0x008277

DECFILT_A_COEF3 = 0x001240

DECFILT_A_COEF4 = 0x005AB5

DECFILT_A_COEF5 = 0x2B29E6

DECFILT_A_COEF6 = 0xCC414E

DECFILT_A_COEF7 = 0x1EB97D

DECFILT_A_COEF8 = 0xF8546A

28.5.2.1.3 eQADC Configuration for Decimation Filter

Configure an Alternate Configuration Control Register (ADC_ACR1 to ADC_ACR8) to select Decimation Filter A as the destination for an ADC conversion, by setting ADC_ACRn[DEST] = 1. To select a signed format, ADC_ACRn[FMTA]=1.

The ADC_ACRn register format has the form:

| | | | | | | | | | | | | | | | | |
|---|------|---|------|---|---|------|---|--------|---|---|--------|----|----------|----|----|----|
| | 0 | 1 | 2 | 3 | 4 | 5 | 6 | 7 | 8 | 9 | 10 | 11 | 12 | 13 | 14 | 15 |
| R | RET_ | 0 | DEST | | | FMTA | 0 | RESSEL | 0 | 0 | ATBSEL | | PRE_GAIN | | | |
| W | INH | | | | | | | | | | | | | | | |

Note that the ADC_ADRn registers are internal to the ADC and can only be accessed indirectly by writing a register write command to the eQADC CFIFO. To do this the CPU should write a command to any eQADC CFIFO with the following format:

| | | | | | | | | | | | | | | | |
|-----------------------|-------|-----|----------|----------|-------------|-----------|------------------------|-----------------|----|----|----|----|----|----|----|
| 0 | 1 | 2 | 3 | 4 | 5 | 6 | 7 | 8 | 9 | 10 | 11 | 12 | 13 | 14 | 15 |
| EOQ | PAUSE | REP | RESERVED | EB (0b0) | BN | R/W (0b0) | ADC_REGISTER HIGH BYTE | | | | | | | | |
| CFIFO Header | | | | | ADC Command | | | | | | | | | | |
| 16 | 17 | 18 | 19 | 20 | 21 | 22 | 23 | 24 | 25 | 26 | 27 | 28 | 29 | 30 | 31 |
| ADC_REGISTER LOW BYTE | | | | | | | | ADC_REG_ADDRESS | | | | | | | |
| ADC Command | | | | | | | | | | | | | | | |

For example, to update ADC_ACR1[DEST] = 1, ADC_ACR1[FMTA]=1

- set the bit field ADC_REG_ADDRESS = 0x30
- set the bit field ADC_REGISTER LOW BYTE = 0x00
- set the bit field ADC_REGISTER HIGH BYTE = 0x06

28.5.2.1.4 eQADC Command

To cause the ADC conversion to be transferred to the Decimation filter selected by the method described in Section 28.5.2.1.3, a Conversion Command for Alternate Configurations must be applied to the eQADC CFIFO. The form of the command is as follows:

| | | | | | | | | | | | | | | | |
|----------------|-------|-----|----------|----------|-------------|-----|-------------|----------------|----|----|-----|-----|------|----|----|
| 0 | 1 | 2 | 3 | 4 | 5 | 6 | 7 | 8 | 9 | 10 | 11 | 12 | 13 | 14 | 15 |
| EOQ | PAUSE | REP | RESERVED | EB (0b0) | BN | CAL | MESSAGE_TAG | | | | LST | TSR | FFMT | | |
| CFIFO Header | | | | | ADC Command | | | | | | | | | | |
| 16 | 17 | 18 | 19 | 20 | 21 | 22 | 23 | 24 | 25 | 26 | 27 | 28 | 29 | 30 | 31 |
| CHANNEL_NUMBER | | | | | | | | ALT_CONFIG_SEL | | | | | | | |
| ADC Command | | | | | | | | | | | | | | | |

The ALT_CONFIG_SEL field should be set to select the ADC_ACRn register that was configured in Section 28.5.2.1.3. For example, if ADC_ACR1 were selected, then the ALT_CONFIG_SEL field should be 0x08.

28.5.2.2 Use Case 2 - Input/Output from/to the CPU/DMA, Stored data filtering.

The input to Filter C is through the memory mapped input register.

Filter C is configured as a 4th order low pass IIR.

The output from the filter is routed to a memory mapped output register and an interrupt is issued when new data is available.

In this example the ADC is not used at all, and no ADC configuration or commands are needed to support the Decimation Filter operation.

Decimation is not enabled.

Saturation is enabled.

28.5.2.2.1 DECFILT_C_MCR — Module Configuration Register settings

Enable interrupt when new filtered data is available: ODEN=1

Enable IIR Filter type: FTYPE=1

Scale coefficients to a range of +1 to -1: SCAL=8

Enable saturation of filter output result: SAT=1

Select the CPU/DMA as the output destination to transfer data to memory mapped output register:
DECFILT_x_MCR[IO_SEL[0:1]] = 01 or 10

Select no decimation: DEC_RATE=0

28.5.2.2.2 DECFILT_C_COEFn

Write the filter coefficients given in [Table 28-20](#) to the following registers.

DECFILT_C_COEF0 = 0x005AB5

DECFILT_C_COEF1 = 0x001240

DECFILT_C_COEF2 = 0x008277

DECFILT_C_COEF3 = 0x001240

DECFILT_C_COEF4 = 0x005AB5

DECFILT_C_COEF5 = 0x2B29E6

DECFILT_C_COEF6 = 0xCC414E

DECFILT_C_COEF7 = 0x1EB97D

DECFILT_C_COEF8 = 0xF8546A

28.5.2.2.3 CPU Interrupt Handler

All sources of interrupts from the Decimation Filters A, B, C and D are routed to separate single vector numbers. Each of the remaining Decimation Filters has a single interrupt vector for all interrupt sources. Decimation Filter C uses vector numbers 467 to 469.

Set INTC vector number 468 to the address of Decimation Filter C output data interrupt handler.

Set the priority for the Decimation Filter and enable interrupts by lowering the processor priority.

When the interrupt occurs, if $\text{DECFLT_C_MSR}[\text{OBIF}] = 1$ then this indicates filter output data is available.

In this case, read the DECFLT_C_OB , then clear the output data interrupt by writing $\text{DECFLT_C_MSR}[\text{OBIC}] = 1$.

Note that $\text{DECFLT_C_MSR}[\text{IBIF}]$ should also be set when the output data interrupt occurs, as a result of the previous write to the input data register, so it should be cleared also by writing $\text{DECFLT_C_MSR}[\text{IBIC}] = 1$. The CPU can now also write a new input value to the DECFLT_C_IB register.

The error flags OVF, OVR and IVR should also be checked at this point, and clear if set, and remedial action taken, if desired by the application.

Chapter 29

Enhanced Time Processing Unit (eTPU2)

29.1 Introduction

eTPU is an intelligent, semi-autonomous co-processor designed for timing control. Operating in parallel with the Host CPU, the eTPU processes instructions, real-time input events, performs output waveform generation, and accesses shared data without Host intervention. Consequently, for each timer event, the Host CPU setup and service times are minimized or eliminated.

High-level assembler, compiler and documentation allows customers to develop their own functions on the eTPU.

eTPU is an enhanced version of the TPU module. Although there is no compatibility at microcode level, eTPU maintains several features of older TPU versions, making it easy to port older applications, at the same time adding several features listed in [Section 29.1.2.2, eTPU Enhancements over TPU3](#).

This document also includes the new features belonging to the version of the eTPU known as eTPU2. The new features are summarized in [Section 29.1.2.3, eTPU2 Enhancements over eTPU](#).

eTPU architecture aims at high resolution timing capabilities. From a system perspective, high resolution timing is limited by Host CPU overhead required for servicing timing tasks such as period measurement, pulse measurement, pulse width modulated waveform generation, etc. On the eTPU, high resolution timing is achieved by three main capabilities:

- Reduced latency: pin actions are immediate.
- Reduce or eliminate host interrupt service time.
- Double action channel capability reducing the channel request rate.

eTPU provides higher resolution than the Host CPU can achieve and creates no Host overhead for servicing timing tasks.

Latency is the interval from occurrence of an event to the start of event servicing. eTPU can service its own events without interrupting the Host. There are two types of timing events:

- Input pin transition.
- Selected Time Base match, i.e., a selected Time Base counter reached or exceeded a pre-programmed value

Service time is the time spent servicing an event. In general, in microcontrollers the service time is constrained because the instruction set is not optimized for time function synthesis. The eTPU instruction set is optimized, so that time functions can be implemented with much fewer instructions than the Host CPU. Instructions execute faster, service time is reduced and program memory compacted.

Instructions executed by the eTPU are connected directly to the eTPU timing hardware and allow parallelism of hardware related actions.

29.1.1 Overview

Figure 29-1 shows a top-level eTPU A/B Module block diagram. It displays a dual eTPU Engine configuration. The eTPU C Module contains a single eTPU Engine configuration.

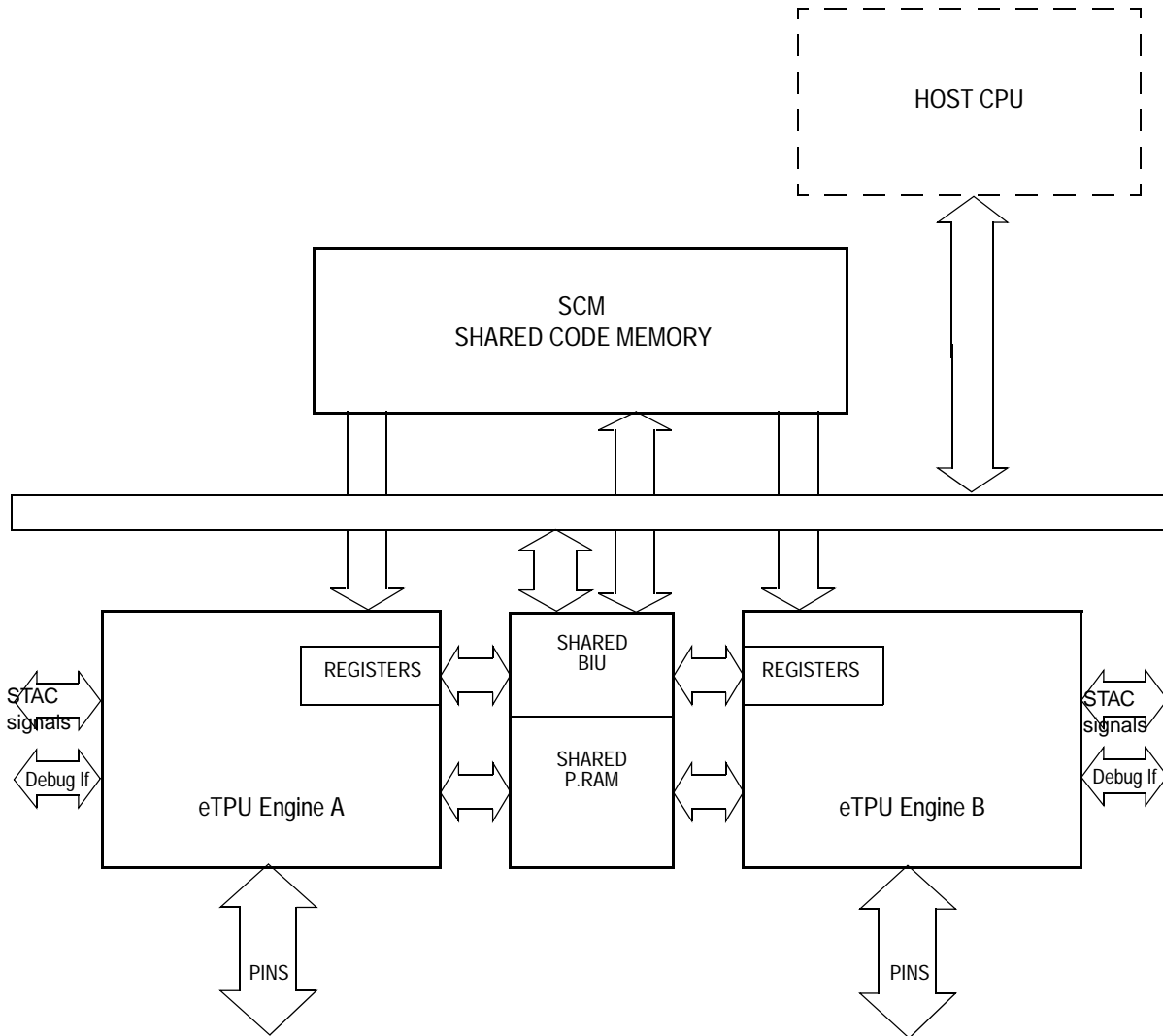

Figure 29-1. eTPU A/B Module Block Diagram

eTPU Engine is responsible for processing input pin transitions and output pin waveform generation based on the **Time Bases**. Each eTPU Engine has its own microprocessor and dedicated hardware for processing signals on I/O pins and can also interface with external time bases through the STAC bus.

Both eTPU Engine CPUs, hereafter called **microengines**, fetch microinstructions from a **Shared Code Memory - SCM**.

Shared Data Memory - SDM - holds eTPU application parameters and work data. It is accessed by Host and both microengines.

Bus Interface Unit - BIU - allows Host to access eTPU registers, SCM and SDM.

Each I/O signal pair is associated with a dedicated **Channel**, which provides hardware for input signal processing and output signal generation, in relationship with selected Time Bases.

The eTPU, as a microprocessed subsystem, works much like a typical real-time system: it runs microengine code from instruction memory (SCM) to handle specific events, accessing data memory (SDM) for parameters, work data and application state info; events may originate from I/O Channels (due to pin transitions and/or time base matches), Host CPU requests or inter-channel requests; events that call for local eTPU processing activate the microengine by issuing a **Service Request**. The Service Request microcode may set an interrupt to the Host CPU. I/O channel events cannot directly interrupt the Host CPU.

Each Channel is associated with a **Function**, which defines its behavior: the Function is a software entity consisting, within the eTPU, of a set of microengine routines that attend to Service Requests. The Function routines are also responsible for Channel configuration. Function routines reside in SCM, which may contain several Functions. A Function may be assigned to several Channels, but a Channel can be associated with just one Function at a given moment. The association between Functions and Channels is defined by Host CPU, and is explained in detail in the *eTPU Reference Manual*.

eTPU hardware supplies resource sharing features that support concurrency:

- a hardware **Scheduler** dispatches the Service Request microengine routines based on a set of priorities defined by the Host CPU. Each Channel has its associated priority;
- a Service Request routine cannot be interrupted until it ends. This sequence of uninterrupted instruction execution is called a **Thread**.
- Channel-specific context (registers and flags) is automatically switched between the end of a Thread and the beginning of the next one.
- SDM arbitration, a dual-parameter coherency controller and semaphores can be used to ensure coherent access to eTPU data shared by both eTPU Engines and Host CPU.

29.1.1.1 eTPU Engine

Each eTPU Engine consists of two 24-bit time bases, 32 independent timer channels, a task scheduler, a microengine, and a Host interface. In addition, each eTPU module has a 32-bit Shared Data Memory (SDM) used for data storage and for passing information between the eTPU Engines and the Host CPU.

Figure 29-2 shows the block diagram for the eTPU Engine.

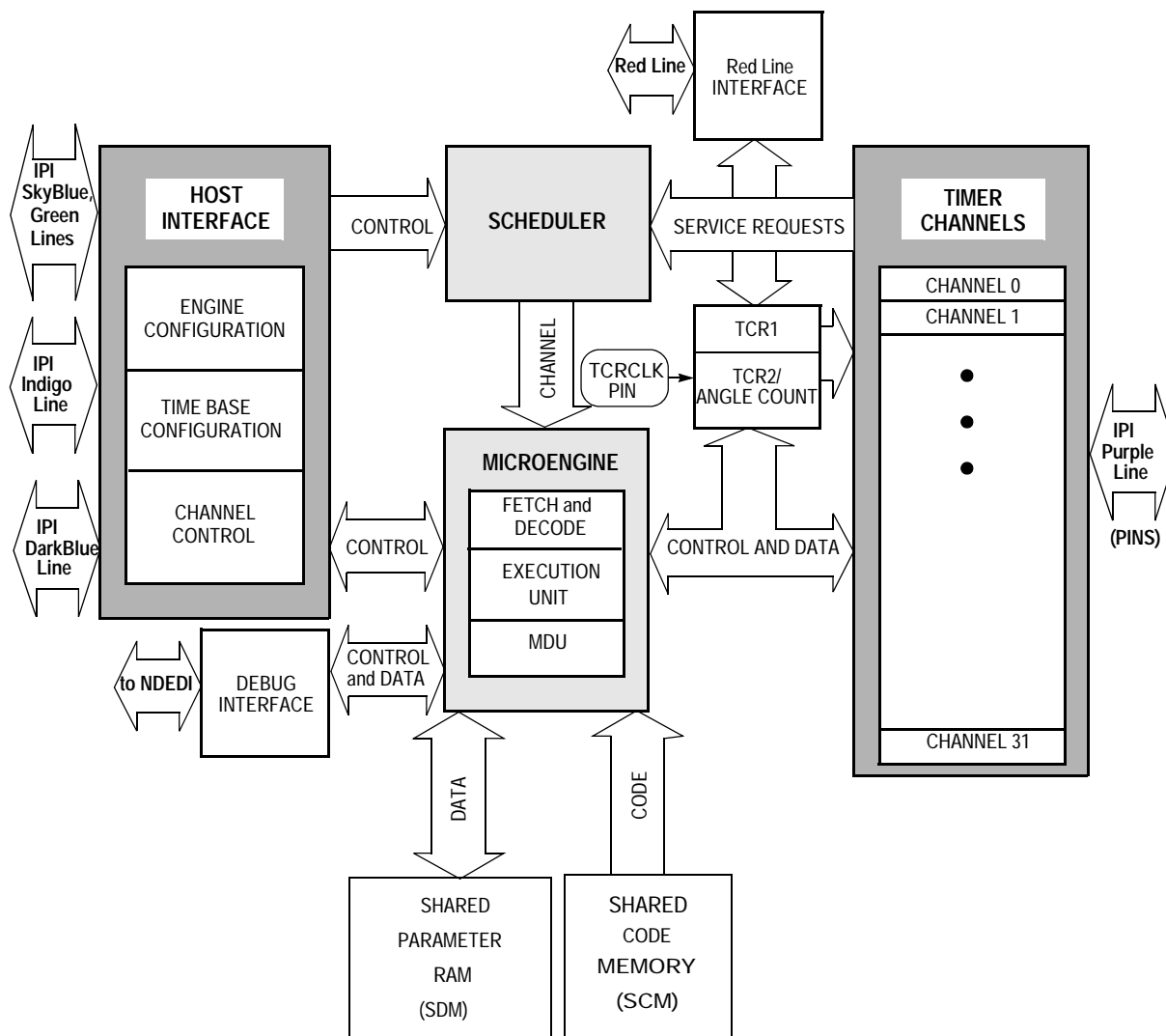

Figure 29-2. eTPU Engine Block Diagram

Throughout this document, the term “eTPU” is sometimes used in place of “eTPU Engine”.

29.1.1.1.1 Time Bases

Two 24-bit counters TCR1 and TCR2 provide reference time bases for all match and input capture events. Prescalers for both time bases are controlled by the Host CPU through bit fields in the eTPU Engine

configuration registers. The eTPU is able to export/import time to/from TCR1 or TCR2 in accordance to the Red Line bus specification.

The clock for each of TCR1 and TCR2 clock can be independently derived from the eTPU clock or from an external input via the TCRCLK clock pin. In addition, the TCR2 timebase can be derived from special angle-clock hardware which enables implementing angle-based functions. This feature is added to support advanced angle based engine control applications.

For further details refer to [Section 29.3.5, Time Bases](#).

29.1.1.1.2 eTPU Timer Channels

Each eTPU Engine has 32 independent channels, each corresponding to an Input/Output signal pair. The channels time resolution is 24 bits, and are all identical.

Each channel consists of logic which supports two events and output controls. The event logic contains two 24-bit capture registers, two 24-bit match registers, greater-equal and equal-only comparators. Supporting two events enables many combinations of double-action functions (for example the channel can handle two events with a single microcode service).

The channel configuration can be changed by the microengine on the fly. Each channel can perform double capture, double match and other capture-match combinations. Channel modes available can do ordered or unordered match. Some modes are also provided that can block one match by the occurrence of the other. Service request can be generated on one or both of the match events.

Input signal can be separated from output signal in each channel. They can, optionally, be combined in a single I/O pin driver. An output buffer enable signal, controlled by microcode, is provided for this case. Digital filters are provided for the input signals, with distinct filtering modes available.

Each channel can use any time base or angle counter for either match or capture operation. For example, a match on TCR1 can capture the value of TCR2. The channels can request service from the microengine due to recognized pin transitions (input events) or timebase matches.

The eTPU channels also support the basic single-action operations found on TPU3 functionality with the exception that time resolution is 24-bits.

Channel configuration combinations:

- Single input capture, no match (TPU3 functionality).
- Single input capture with single match timeout (TPU3 functionality).
- Single input capture with double match timeout with several double match sub-modes.
- Double input capture with single or double match timeout with several double match sub-modes.
- Single output match (TPU3 functionality).
- Double output match with several double match sub-modes.
- Input-dependent output generation.

The double match functionality has various combinations for generation of service request and determining pin actions. For more details refer to the *eTPU Reference Manual*.

In addition to the predefined channel configurations above, the user can also program its own channel configuration, defining how input captures, matches and service-requests are related.

29.1.1.1.3 Host Interface

The Host interface allows the Host CPU to control the operation of the eTPU. The Host CPU must initialize the eTPU by writing to the appropriate Host interface registers to assign a Function and priority to each channel. In addition, the Host writes to the Host Service Request and channel configuration registers to further define Function operation for each initialized channel. Refer to [Section 29.3.2, Host Interface](#), for a detailed description.

When the SCM is implemented by RAM, the Host must first initialize it with the proper microcode program prior to enabling any eTPU Function, and then enable eTPU access (which also disables Host access).

29.1.1.1.4 Shared Data Memory - SDM

The SDM works as data RAM which can be accessed by the Host CPU and up to two eTPU Engines. This memory is used for information transfer between the Host CPU and the eTPU, as data storage for the eTPU microcode program or for communication between the two eTPU Engines. SDM width is 32 bits, and is accessible by the Host as byte, 16-bit or 32-bit wide. eTPU can access it as full 32-bits, lower 24-bits or upper byte (8-bit).

The host can also access the SDM space mirrored in other area with Parameter Signal Extension (PSE). Parameter Signal Extension accesses differ from the usual host accesses to the original SDM area as follows:

- Writes are effective only to the lower 3 bytes of a word: the word's most significant byte is kept unaltered in SDM.
- Reads return the lower 3 bytes of a word sign-extended to 32 bits, i.e.: the most significant bit of the word's 2nd most significant byte is copied in all 8 bits of the most significant read byte.

Each eTPU channel can be associated with a variable number of parameters located in the SDM, according to its selected Function. In addition, the SDM can be fully shared between two eTPU Engines, enabling direct communication between them.

High flexibility of the SDM utilization is achieved as follows:

- Each channel has a programmable base address pointing to the address of its first parameter with two parameter granularity. This way the SDM can be partitioned according to the actual function needs.
- The microcode can access the first 128 parameters of the selected channel in channel relative access mode.
- Each Engine can access all the SDM address space in indirect addressing mode. Blocks of data are easily transferred using stack operation.
- Absolute addressing mode can access the first 256 parameters (TPU3 functionality), implementing a shared pool of parameters holding global variables.

In the Host address space each parameter occupies four bytes. eTPU usage of the upper byte is achieved by having a 32-bit P register which can access the upper byte, the lower 24 bits or all the 32 bits. The microcode can switch between access sizes at any time.

Each Function may require a different number of parameters. During the eTPU initialization the Host has to program channel base addresses, allocating proper parameters for each channel according to its selected Function.

29.1.1.1.5 Scheduler

Out of reset, all channels are disabled. The Host CPU makes a channel active by assigning it one of three priorities: high, middle, or low. The Scheduler determines the order in which channels are serviced based on channel number and assigned priority. The priority mechanism, implemented in hardware, ensures that all requesting channels are serviced. For additional details refer to [Section 29.3.3, Scheduler](#).

29.1.1.1.6 Microengine

eTPU microengine executes each instruction in a microcycle of two system clocks, while prefetching the next instruction through an instruction pipeline. Instruction execution time is constant unless it gets wait states from the SDM arbitration. Two eTPU Engines share code memory without having any performance degradation by interleaving their accesses (the Shared Code Memory has one-clock access time).

Instruction width is 32 bits. The microengine instruction set provides basic arithmetic and logic operations, flow control (jumps and subroutine calls), SDM access, and Channel configuration and control. The instruction formats are defined in such a way that allow particular combinations of two or three of these operations with unconflicting resources to be executed in parallel in the same microcycle.

Microengine has also an independent Multiply/Divide/MAC unit that performs these complex operations in parallel with other microengine instructions.

Channel functionality is tightly integrated to the instruction set through Channel Control operations and conditional Branch operations, which support jumps/calls on Channel-specific conditions. This allows quick and terse Channel configuration and control code, contributing to reduced service time.

29.1.1.1.7 Dual eTPU Engine Module

The eTPU A/B implementation includes two eTPU Engines sharing SDM and the same code in SCM.

The two eTPU Engines share the Bus Interface Unit (BIU) and the data memory (SDM) which enable Host-eTPU and eTPU Engine-Engine communication. The shared BIU includes coherency logic which supports dual parameter (8 bytes) coherency in transfers between Host and eTPU, using a temporary parameter area within the SDM. More details on this can be found on [Section 29.3.4, Parameter Sharing and Coherency](#).

29.1.2 Features

29.1.2.1 eTPU Feature Summary

The eTPU includes these distinctive features:

- up to 32 channels for each eTPU Engine, each channel is associated with an Input/Output signal pair.
 - enhanced input digital filters on the input pins for improved noise immunity. The eTPU digital filter can use 2 samples, 3 samples or work in continuous mode.
 - identical, orthogonal channels, except for channel 0: each channel can perform any time function. Each time function can be assigned to more than one channel at a given time, so each signal can have any functionality. Channel 0 has the same capabilities of the others, but can also work with special Angle Counter logic (see below).
 - Link Service Request allows activation of a Channel function by request of another channel, even between eTPU Engines.
 - Host Service Request allows activation of a Channel function by Host CPU request
 - each channel has an event mechanism which supports single and double action functionality in various combinations. It includes two 24-bit capture registers, two 24-bit match registers, 24-bit greater-equal and equal-only comparators.
- Two independent 24-bit time bases for channel synchronization:
 - first time base clocked by system clock with programmable prescaler division from 1 to 512 (in steps of 2), or by output of second time base prescaler.
 - first time base can also be clocked by external signal with programmable prescaler division of 1 to 256.
 - second time base clocked by external signal with programmable prescaler division from 1 to 64.
 - second time base external clock source can be replaced by system clock divided by 8.
 - both time bases can be exported or imported via Shared Time and Counter bus.
 - second time base counter can work as an Angle counter, enabling angle based applications to match angle instead of time.
 - second time base can also be used as a pulse accumulator gated by external signal.
- Event-Triggered VLIW processor (microengine):
 - 2 stage pipeline implementation (fetch and execution), with separate instruction memory - SCM - and data memory - SDM (Harvard architecture)
 - fixed-length instruction execution in two system clock microcycle
 - interleaved SCM access in dual eTPU Engine avoids contention in time for instruction memory
 - SCM address space of up to 16K positions (64 Kbytes)
 - SDM with interleaved access in dual eTPU Engine avoids contention for data memory
 - SDM address space of up to 8 Kbytes (both Engines).
 - instruction set with embedded Channel support, including specialized Channel control subinstructions and conditional branching on Channel-specific flags.
 - channel-oriented addressing: channel-bound address mode with Host configured Channel Base Address allows channel data isolation, independent of microengine application code.
 - channel-bound data address space of up to 128 32-bit parameters (512 bytes)

- global parameter address mode allows access to common Channel data of up to 256 32-bit parameters (1024 bytes)
- support for indirect and stacked data access schemes.
- parallel execution of: data access, ALU, Channel control and flow control subinstructions in selected combinations.
- 32-bit microengine registers and 24-bit resolution ALU, with 1 microcycle addition and subtraction, absolute value, bitwise logical operations on 24-bit, 16-bit, or byte operands; single bit manipulation, shift operations, sign extension and conditional execution.
- additional 24-bit Multiply/MAC/Divide unit which supports all signed/unsigned Multiply/MAC combinations, and unsigned 24-bit Divide. The MAC/Divide unit works in parallel with the regular microcode commands.
- Resource sharing features support channel sharing of channel registers, memory and microengine time:
 - hardware Scheduler works as a “task management” unit, dispatching event service routines by predefined, Host-configured priority.
 - automatic Channel context switch when a “task switch” occurs, i.e., one Function Thread ends and another begins to service a request from other Channel: Channel-specific registers, flags and parameter base address are automatically loaded for the next serviced channel.
 - individual channel priority setting in 3 levels: high, middle and low.
 - Scheduler priority scheme allows calculation of worst case latency for event servicing and ensures servicing all channels by preventing permanent blockage.
 - SDM shared between Host CPU and both eTPU Engines, supporting communication either between Channels and Host or inter-channel.
 - hardware implementation of 4 Semaphores supports resource sharing between both eTPU Engines.
 - Hardware semaphores directly supported by the microengine instruction set.
 - dual parameter coherency hardware support allows atomic (to host) access to 2 parameters by microengine(s) in back-to-back accesses.
 - coherent dual-parameter controller allows atomic (to microengines) accesses to 2 parameters by the host.
- Development support features:
 - Nexus class 3 debug support.
 - Software breakpoints.
 - Debug interface supporting single-step execution, forced microinstruction execution, Hardware breakpoints and watchpoints on several conditions.
- Safety support features:
 - SCM (code memory) continuous signature-check built-in self test (MISC - Multiple Input Signature Calculator), runs concurrently with eTPU normal operation.
- (more on [Section 29.1.2.3, eTPU2 Enhancements over eTPU](#)).

29.1.2.2 eTPU Enhancements over TPU3

- 32 orthogonal channels with enhanced functionality. Full support for double action with double match and double transition sub-mode combinations.
- Input and Output features separated in channel logic and microinstructions, allowing input and output signals to be processed separately or combined.
- Increased time resolution and execution unit to 24 bits.
- Increased linear code memory, shared by two eTPU Engines, configurable up to 16K positions (64 Kbytes).
- Increased SDM address range (8 Kbytes each Engine) and width (32 bits per parameter). The SDM can be dynamically allocated to support variable number of parameters for each channel. Each channel can have access to at least 256 parameters.
- The SDM is fully shared by two eTPU Engines (SDM), supporting direct inter-engine communication with the help of hardware semaphores.
- Enhanced arithmetic operations, including add/subtract with carry, absolute value, multiple shift and rotate, conditional execution with variable operand widths.
- Enhanced logic operations, including bitwise operations (and, or, xor) and bit manipulation, with conditional execution. Support for read-modify-write of any bit in the SDM.
- Hardware for Multiply/MAC/Divide, running in parallel to execution of other operations. The 24-bit divide result is available after 13 other unrelated instructions. Multiplication supports any data width of both operands (8, 16 or 24 bits), signed or unsigned. A 24x24 Multiply/MAC result is available after four other unrelated instructions. A 24x8 Multiply/MAC result is available after one other unrelated instruction.
- Supports export/import of time bases from other sources through the real time bus (STAC - Shared Time and Counter bus). This internal bus is used for sharing real time data between multiple peripherals.
- Contains angle clock hardware, supported by microcode, which can provide a 24-bit angle bus instead of time bus. This feature enables the eTPU to run angle based engine control applications.
- More interrupt types. Each eTPU channel can generate a data transfer request interrupt, in addition to regular interrupts, and one global exception interrupt. Data Transfer requests can be used either as interrupt sources or DMA requests. This feature takes advantage of DMA peripherals which off-load the Host. Interrupt Overflow status is also provided.
- Improved visibility to the Host (pin states, time bases, serviced channel).
- An edge case of priority inversion on TPU3 Scheduler was resolved.
- Supports channel link requests between eTPU Engines.

29.1.2.3 eTPU2 Enhancements over eTPU

- TCR1, channel logic and digital filters (both channel and TCRCLK) now have an option to run at divisions of full system clock speed, besides eTPU clock / 2.
- Channels support unordered transitions: transition B can now be detected before transition A. Related to this enhancement, TDLA and TDLB can now be independently negated by microcode. Refer to the *eTPU Reference Manual* for details.

- Channel logic can now work on full eTPU clock, allowing faster response with slow clocks.
- Added a new User Programmable Channel Mode: the blocking, enabling, service request and capture characteristics of this channel mode can be programmed via microcode. Refer to the *eTPU Reference Manual* for details.
- Microinstructions now provide an option to issue Interrupt and Data Transfer requests selected by CHAN. They can also be requested simultaneously at the same instruction. Refer to the *eTPU Reference Manual* for details.
- Channel Flags 0 and 1 can now be tested for branching, besides selecting the entry point. Refer to the *eTPU Reference Manual* for details.
- Channel digital filters can be bypassed, and can be clocked by full eTPU clock ([Section 29.3.4.4.4, Bypass Mode](#)).
- Scheduler priority-passing mechanism can now be disabled ([Section 29.3.3.2.2, Priority Passing Disabling](#)).
- New Watchdog mechanism kills threads over a programmable timeout ([Section 29.3.1, Watchdog](#)).
- New counter allows microengine load information collection for performance analysis ([Section 29.3.7.1, Idle Counter](#)).
- Channels 1 and 2 (besides channel 0) can now be selected to control the EAC ([Section 29.2.6.1, ETPUTBCR - eTPU Time Base Configuration Register](#)).
- Timebase prescalers are now reset when the GTBE input is negated, guaranteeing synchronization with eMIOS in all cases ([Section 29.3.5.4, GTBE - Global Time Base Enable](#)).
- New MISC flag indicates when an SCM signature calculation round is completed. This allows measuring of the average MISC scan period in a real application situation ([Section 29.2.5.1, ETPUMCR - eTPU Module Configuration Register](#)).
- New channel TCCEA flag allows continuous capture even after TDLA is set, making it fully compatible with TPU behavior. Refer to the *eTPU Reference Manual* for details.
- New branch condition PRSS tells the pin state at the time when a channel (match or transition) service request occurred. Refer to the *eTPU Reference Manual* for details.
- MRLEA/B can now be negated independently by microcode. Refer to the *eTPU Reference Manual* for details.
- New Engine Relative address mode allows a function to access SDM address space common to one engine, but distinct between engines. Refer to the *eTPU Reference Manual* for details.

NOTE

All changes above are backward compatible with the classic eTPU, so that legacy object code (both Host and microcode) runs on eTPU2 without modification.

29.1.3 Modes of Operation

eTPU can be seen as capable of working in the following modes:

- **User Configuration Mode**

User has the ability to program the eTPU Cores with User Time Functions, having access to the Shared Code Memory (SCM).

- **User Mode**

User does not access the eTPU Shared Code Memory:

- Use of predefined eTPU Functions
- No need for eTPU Core programming ability

- **Debug Mode**

User debugs eTPU code, accessing special Trace/Debug features via Nexus interface:

- hardware breakpoint/watchpoint setting
- access to internal registers
- single-step execution
- forced instruction execution
- software breakpoint insertion and removal.

- **Module Disable Mode**

eTPU Engine clocks are stopped through a register write to ETPUECR bit MDIS, saving power. Input sampling stops. eTPU Engines can be in Module Disable Mode independently. Module Disable Mode stops only the Engine clock, so that the Shared BIU, and Global Channel registers can be accessed, and interrupts and DMAs can be cleared and enabled/disabled. An Engine only enters Module Disable Mode when any currently running thread is finished. Refer to the *eTPU Reference Manual* for details.

- **Stop Mode**

Stop Mode is entered when eTPU answers device stop request assertion with stop acknowledge. Refer to the SIU_HLT and SIU_HLTACK register descriptions for details on how to place this module in Stop mode.

These modes are loosely selected: there is no unique register field or signals to choose between them. Some features of one mode can be used with features of other mode(s). More on this subject can be found on [Section 29.1.3.1, eTPU Mode Selection](#), below.

NOTE

Throughout this document, an engine is said to be “stopped” if it is either in Module Disable mode or Stop mode.

29.1.3.1 eTPU Mode Selection

User and User Configuration are the normal operating modes, and differ from each other only in access to SCM. User programmability is only possible with a RAM SCM.

Debug Mode is characterized by the use of the debug interface features. Specifically, Nexus blocks provide Nexus class 3 debug features. For more information on debug features, refer to the *eTPU Reference Manual*.

Module Disable Mode is entered by setting ETPUECR register bit MDIS. eTPU Engines can be individually stopped going into Module Disable Mode (there is one ETPUECR register for each Engine). Each engine can leave Module Disable Mode by writing MDIS=0 (which can only be done if VIS=0).

Stop Mode is activated by IP-Bus (device stop request). In this case, the eTPU waits for both eTPU Engines to enter in stop mode, and then asserts the stop acknowledge line. eTPU leaves Stop Mode when device stop request is negated, but only if VIS=0. If device stop request is negated and VIS=1, eTPU will leave Stop Mode as soon as VIS=0.

NOTE

An Engine can stay in Module Disable mode when it leaves Stop Mode if its bit MDIS=1, even if the other leaves it.

29.2 External Signal Description

29.2.1 Overview

There are 69 external signals associated with each eTPU Engine: 32 channel input signals, 32 channel output signals, 4 output disable inputs, and TCRCLK clock input, totalling 138 in a Dual Engine system.

The TCRCLK signal is used to clock TCR1/2 counters or gate the TCR2 clock. In Angle Mode it is used as tooth signal input.

29.2.2 Detailed Signal Descriptions

29.2.2.1 eTPU Channel Output Signals [0-31]

Each channel output signal is associated with a channel. The microcode may affect the logic level of an output signal¹ by implementing one of two actions:

- Specify the logic level output to the signal when there is a match or a transition.
- Immediately force a logic level.

The output signal may also be forced to a logic level, independently of the output value from the channel logic, by one of the four (each Engine) output disable signals (see [Section 29.2.2.4, eTPU Channel Output Disable Signals](#)).

29.2.2.2 eTPU Channel Input Signals [0-31]

Each channel input signal is associated with a channel. The microcode can directly control the effect of the transition edge. Each channel can be programmed to sense a transition when a rising and/or falling edge is detected. The channel logic can also process two transition events, and relate these events to each other and to other programmed timer events. The edge sensitivities of the two transition events are configured independently by microcode.

1. Note that the minimum pulse width is one microcycle (two eTPU clocks), and slow 5V pads may not be able to transfer it on time. For generation of very short pulses the eTPU pads have to be programmed by the system integration for fast operation mode with the voltage levels defined for fast pad operation in the MCU technology.

Each channel input signal has an associated synchronizer made of two flip-flops sampling the signal on every other eTPU clock, followed by a digital filter. This digital filter can work in three sub-modes, whose purpose is to filter out noise pulses that have width less than a programmed value of eTPU clocks, preventing these transitions from being input to the transition detect logic. The synchronizer and digital filter are guaranteed to pass pulses that are greater than a programmed value. All channel input filters in one Engine work on the same mode and sampling clock. For more information on channel input filters, refer to [Section 29.3.4.4, Enhanced Digital Filter - EDF](#). In one of the Angle Modes, the output of the digital filter of channel 0 is replaced by the output of TCRCLK signal digital filter. Refer to the *eTPU Reference Manual* for details.

29.2.2.3 Time Base Clock Signal — TCRCLK

TCRCLK is an input signal used to control the Time Bases TCR1 and TCR2. There is one independent TCRCLK input for each Engine. For pulse accumulator operations TCRCLK can be used as a gate for a counter based on the eTPU clock divided by eight. For Angle operations TCRCLK can be used to get the tooth transition indications in Angle Mode.

Like the channel input signals, the TCRCLK signal has an associated synchronizer followed by a digital filter. This digital filter can work in two sub-modes, whose purpose is to filter out noise pulses that have width less than a programmed value of eTPU clocks, preventing these transitions from being input to the transition detect logic. The synchronizer and digital filter are guaranteed to pass pulses that are greater than a programmed value. The clock and operation sub-mode of the TCRCLK filter is configured independently of the other channel input filters, through the field TCRCF in register ETPUTBCR. For more information on filter sub-modes, refer to [Section 29.3.5.5, TCRCLK Digital Filter](#). In one of the Angle Modes, the output of the digital filter of channel 0 is replaced with the output of TCRCLK signal digital filter.

29.2.2.4 eTPU Channel Output Disable Signals

Each eTPU engine has 4 input signals to force the outputs of a group of 8 channels to an inactive level. When an input disable signal is active, all the channels in its group of 8 that have their ODIS bits set to 1 in ETPUCxCR register have their outputs forced to the opposite of the value specified in bit OPOL of the same register. Therefore, channels can be individually selected to be affected by the output disable signals, as well as their disabling forced polarity.

The output disable channel groups are defined in [Table 29-2](#).

Table 29-2. Output Disable Channel Groups

| eMIOS Channel | Engine | Channels |
|---------------|--------|----------|
| 11 | A | 0 to 7 |
| 10 | | 8 to 15 |
| 9 | | 16 to 23 |
| 8 | | 24 to 31 |

Table 29-2. Output Disable Channel Groups (continued)

| eMIOS Channel | Engine | Channels |
|---------------|--------|----------|
| 20 | B | 0 to 7 |
| 21 | | 8 to 15 |
| 22 | | 16 to 23 |
| 23 | | 24 to 31 |

29.2.3 Memory Map/Register Definition

The guideline for the description of all bits and fields throughout this section is to provide only a brief explanation (without examples or method of use) of the features, since it will be used mainly as a reference for the reader that is studying [Section 29.3, Functional Description](#), where those features are explained in detail.

29.2.4 Memory Map

The eTPU System simplified memory map is shown in [Table 29-4](#). Each of the register areas shown may have their own reserved address areas.

[Table 29-5](#) show detailed memory maps. Offsets are relative to the eTPU Base addresses given in [Table 29-3](#).

Table 29-3. eTPU Module Base Addresses

| eTPU Module | Base address |
|-------------|--------------|
| A/B | 0xC3FC_0000 |

SCM unused area is decoded and returns a fixed opcode defined in the register ETPUSCMOFFDATAR.

Table 29-4. High Level Memory Map

| Offset | Use |
|-------------|-----------------------------------|
| 0x00-0x1F | System Configuration Registers |
| 0x20-0x2F | eTPU A Time Base Registers |
| 0x30-0x3F | Reserved ¹ |
| 0x40-0x4F | eTPU B Time Base Registers |
| 0x50-0x5F | Reserved ¹ |
| 0x60-0x6F | eTPU A Extra Engine Registers |
| 0x70-0x7F | eTPU B Extra Engine Registers |
| 0x80-0xFF | Reserved ¹ |
| 0x100-0x13F | Memory Error Support Registers |
| 0x140-0x1FF | Reserved ¹ |
| 0x200-0x2FF | eTPU A/B Global Channel Registers |
| 0x300-0x3FF | Reserved ¹ |
| 0x400-0x7FF | eTPU A Channel Registers |
| 0x800-0xBFF | eTPU B Channel Registers |
| 0xC00-0xFFF | Reserved ¹ |

Table 29-4. High Level Memory Map (continued)

| | |
|-------------------------|---|
| 0x1000-0x3FFF | Reserved ¹ |
| 0x4000-0x7FFF | Reserved ¹ |
| 0x8000 - 0x97FF | eTPU A/B SDM - Shared Data Memory |
| 0xC000 - 0xFFFF | eTPU A/B SDM PSE mirror ² |
| 0x10000 - 0x15FFF | eTPU A/BSCM - Shared Code Memory ³ |

¹ Reserved addresses must not be used. Access to these memory positions complete with 0-wait-states, but the behavior is unspecified.

² Parameter Sign Extension access area, see [Section 29.3.2.3, Parameter Access](#).

³ SCM access is available only when bit VIS=1 on register ETPUMCR, under certain conditions (see [Section 29.2.5.1, ETPUMCR - eTPU Module Configuration Register](#)).

Table 29-5. Detailed Memory Map eTPU A/B

| Offset | Register | Bits | Access | Reset Value | Section/Page |
|-----------|---|------|--------|-------------|--------------------------------|
| 0x00 | ETPUMCR—eTPU Module Configuration Register | 32 | R/W | 0x000U_0000 | 29.2.5.1/29-19 |
| 0x04 | ETPUCDCR—eTPU Coherent Dual-Parameter Controller Register | 32 | R/W | 0x0000_0000 | 29.2.5.2/29-22 |
| 0x08 | Reserved | | | | |
| 0x0C | ETPUMISCCMPR—eTPU MISC Compare Register | 32 | R/W | 0x0000_0000 | 29.2.5.3/29-23 |
| 0x10 | ETPUSCMOFFDATAR—eTPU SCM Off-range Data Register ¹ | 32 | R/W | 0xf3775ffb | 29.2.5.4/29-24 |
| 0x14 | ETPUECR_A—eTPU A Engine Configuration Register | 32 | R/W | 0x0000_0000 | 29.2.5.5/29-24 |
| 0x18 | ETPUECR_B—eTPU B Engine Configuration Register | 32 | R/W | 0x0000_0000 | 29.2.5.5/29-24 |
| 0x1C | Reserved | | | | |
| 0x20 | ETPUTBCR_A—eTPU A Time Base Configuration Register | 32 | R/W | 0x2000_0000 | 29.2.6.1/29-28 |
| 0x24 | ETPUTB1R_A—eTPU A Time Base 1 | 32 | R/W | 0x0000_0000 | 29.2.6.2/29-31 |
| 0x28 | ETPUTB2R_A—eTPU A Time Base 2 | 32 | R/W | 0x0000_0000 | 29.2.6.3/29-31 |
| 0x2C | ETPUREDCR_A—eTPU A STAC Configuration Register | 32 | R/W | 0x0U00_0U00 | 29.2.6.4/29-32 |
| 0x30–0x3C | Reserved | | | | |
| 0x40 | ETPUTBCR_B—eTPU B Time Base Configuration Register | 32 | R/W | 0x2000_0000 | 29.2.6.1/29-28 |
| 0x44 | ETPUTB1R_B—eTPU B Time Base 1 | 32 | R/W | 0x0000_0000 | 29.2.6.2/29-31 |
| 0x48 | ETPUTB2R_B—eTPU B Time Base 2 | 32 | R/W | 0x0000_0000 | 29.2.6.3/29-31 |
| 0x4C | ETPUREDCR_B—eTPU B STAC Configuration Register | 32 | R/W | 0x0U00_0U00 | 29.2.6.4/29-32 |

Table 29-5. Detailed Memory Map eTPU A/B (continued)

| Offset | Register | Bits | Access | Reset Value | Section/Page |
|-------------|---|------|--------|-------------|--------------------------------|
| 0x50–0x5C | Reserved | | | | |
| 0x60 | ETPUWDTR_A—eTPU A Watchdog Timer Register | 32 | R/W | 0x0000_0000 | 29.2.7.1/29-33 |
| 0x64 | Reserved | | | | |
| 0x68 | ETPUIDLER_A—eTPU A Idle Counter Register | 32 | R/W | 0x0000_0000 | 29.2.7.2/29-34 |
| 0x6C | Reserved | | | | |
| 0x70 | ETPUWDTR_B—eTPU B Watchdog Timer Register | 32 | R/W | 0x0000_0000 | 29.2.7.1/29-33 |
| 0x74 | Reserved | | | | |
| 0x78 | ETPUIDLER_B—eTPU B Idle Counter Register | 32 | R/W | 0x0000_0000 | 29.2.7.2/29-34 |
| 0x7C–0x1FF | Reserved | | | | |
| 0x200 | ETPUCISR_A—eTPU A Channel Interrupt Status Register | 32 | R/W | 0x0000_0000 | 29.2.9.1/29-35 |
| 0x204 | ETPUCISR_B—eTPU B Channel Interrupt Status Register | 32 | R/W | 0x0000_0000 | 29.2.9.1/29-35 |
| 0x208–0x20C | Reserved | | | | |
| 0x210 | ETPUCDTRSR_A—eTPU A Channel Data Transfer Request Status Register | 32 | R/W | 0x0000_0000 | 29.2.9.2/29-36 |
| 0x214 | ETPUCDTRSR_B—eTPU B Channel Data Transfer Request Status Register | 32 | R/W | 0x0000_0000 | 29.2.9.2/29-36 |
| 0x218–0x21C | Reserved | | | | |
| 0x220 | ETPUCIOSR_A—eTPU A Channel Interrupt Overflow Status Register | 32 | R/W | 0x0000_0000 | 29.2.9.3/29-37 |
| 0x224 | ETPUCIOSR_B—eTPU B Channel Interrupt Overflow Status Register | 32 | R/W | 0x0000_0000 | 29.2.9.3/29-37 |
| 0x228–0x22C | Reserved | | | | |
| 0x230 | ETPUCDTROSR_A—eTPU A Channel Data Transfer Request Overflow Status Register | 32 | R/W | 0x0000_0000 | 29.2.9.4/29-38 |
| 0x234 | ETPUCDTROSR_B—eTPU B Channel Data Transfer Request Overflow Status Register | 32 | R/W | 0x0000_0000 | 29.2.9.4/29-38 |
| 0x238–0x23C | Reserved | | | | |
| 0x240 | ETPUCIER_A—eTPU A Channel Interrupt Enable Register | 32 | R/W | 0x0000_0000 | 29.2.9.5/29-39 |
| 0x244 | ETPUCIER_B—eTPU B Channel Interrupt Enable Register | 32 | R/W | 0x0000_0000 | 29.2.9.5/29-39 |
| 0x248–0x24C | Reserved | | | | |
| 0x250 | ETPUCDTRER_A—eTPU A Channel Data Transfer Request Enable Register | 32 | R/W | 0x0000_0000 | 29.2.9.6/29-39 |
| 0x254 | ETPUCDTRER_B—eTPU B Channel Data Transfer Request Enable Register | 32 | R/W | 0x0000_0000 | 29.2.9.6/29-39 |
| 0x258–0x27F | Reserved | | | | |
| 0x280 | ETPUCPSSR_A—eTPU A Channel Pending Service Status Register | 32 | R | 0x0000_0000 | 29.2.9.7/29-40 |
| 0x284 | ETPUCPSSR_B—eTPU B Channel Pending Service Status Register | 32 | R | 0x0000_0000 | 29.2.9.7/29-40 |
| 0x288–0x28C | Reserved | | | | |

Table 29-5. Detailed Memory Map eTPU A/B (continued)

| Offset | Register | Bits | Access | Reset Value | Section/Page |
|---------------|---|------|--------|-------------|---------------------------------|
| 0x290 | ETPUCSSR_A—eTPU A Channel Service Status Register | 32 | R | 0x0000_0000 | 29.2.9.8/29-41 |
| 0x294 | ETPUCSSR_B—eTPU B Channel Service Status Register | 32 | R | 0x0000_0000 | 29.2.9.8/29-41 |
| 0x298–0x3FF | Reserved | | | | |
| 0x400 | ETPUC0CR_A—eTPU A Channel 0 Configuration Register | 32 | R/W | 0x0000_0000 | 29.2.10.1/29-43 |
| 0x404 | ETPUC0SCR_A—eTPU A Channel 0 Status and Control Register | 32 | R/W | 0x0000_0000 | 29.2.10.2/29-45 |
| 0x408 | ETPUC0HSRR_A—eTPU A Channel 0 Host Service Request Register | 32 | R/W | 0x0000_0000 | 29.2.10.3/29-47 |
| 0x40C | Reserved | | | | |
| 0x410 | ETPUC1CR_A—eTPU A Channel 1 Configuration Register | 32 | R/W | 0x0000_0000 | 29.2.10.1/29-43 |
| 0x414 | ETPUC1SCR_A—eTPU A Channel 1 Status and Control Register | 32 | R/W | 0x0000_0000 | 29.2.10.2/29-45 |
| 0x418 | ETPUC1HSRR_A—eTPU A Channel 1 Host Service Request Register | 32 | R/W | 0x0000_0000 | 29.2.10.3/29-47 |
| 0x41C | Reserved | | | | |
| | . | | | | |
| 0x5F0 | ETPUC31CR_A—eTPU A Channel 31 Configuration Register | 32 | R/W | 0x0000_0000 | 29.2.10.1/29-43 |
| 0x5F4 | ETPUC31SCR_A—eTPU A Channel 31 Status and Control Register | 32 | R/W | 0x0000_0000 | 29.2.10.2/29-45 |
| 0x5F8 | ETPUC31HSRR_A—eTPU A Channel 31 Host Service Request Register | 32 | R/W | 0x0000_0000 | 29.2.10.3/29-47 |
| 0x5FC - 0x7FF | Reserved | | | | |
| 0x800 | ETPUC0CR_B—eTPU B Channel 0 Configuration Register | 32 | R/W | 0x0000_0000 | 29.2.10.1/29-43 |
| 0x804 | ETPUC0SCR_B—eTPU B Channel 0 Status and Control Register | 32 | R/W | 0x0000_0000 | 29.2.10.2/29-45 |
| 0x808 | ETPUC0HSRR_B—eTPU B Channel 0 Host Service Request Register | 32 | R/W | 0x0000_0000 | 29.2.10.3/29-47 |
| 0x80C | Reserved | | | | |
| 0x810 | ETPUC1CR_B—eTPU B Channel 1 Configuration Register | 32 | R/W | 0x0000_0000 | 29.2.10.1/29-43 |
| 0x814 | ETPUC1SCR_B—eTPU B Channel 1 Status and Control Register | 32 | R/W | 0x0000_0000 | 29.2.10.2/29-45 |
| 0x818 | ETPUC1HSRR_B—eTPU B Channel 1 Host Service Request Register | 32 | R/W | 0x0000_0000 | 29.2.10.3/29-47 |
| 0x81C | Reserved | | | | |
| | . | | | | |
| | . | | | | |
| | . | | | | |
| 0x9F0 | ETPUC31CR_B—eTPU B Channel 31 Configuration Register | 32 | R/W | 0x0000_0000 | 29.2.10.1/29-43 |

Table 29-5. Detailed Memory Map eTPU A/B (continued)

| Offset | Register | Bits | Access | Reset Value | Section/Page |
|--------------------------------|---|------|--------|-------------|---------------------------------|
| 0x9F4 | ETPUC31SCR_B—eTPU B Channel 31 Status and Control Register | 32 | R/W | 0x0000_0000 | 29.2.10.2/29-45 |
| 0x9F8 | ETPUC31HSRR_B—eTPU B Channel 31 Host Service Request Register | 32 | R/W | 0x0000_0000 | 29.2.10.3/29-47 |
| 0x9FC - 0x7FFF | Reserved | | | | |
| 0x8000 - 0x97FF | SPRAM—Shared Parameter RAM | — | — | — | — |
| 0xC000 - 0xFFFF | SPRAM—Shared Parameter RAM - PSE mirror ² | — | — | — | — |
| 0x10000 - 0x15FFF ³ | SCM—Shared Code Memory ⁴ | — | — | — | — |

- ¹ This register is not implemented in some MCUs; see [Section 29.2.5.4, ETPUSCMOFFDATAR - eTPU SCM Off-range Data Register](#).
- ² Parameter Sign Extension access area, see [Section 29.3.2.3, Parameter Access](#).
- ³ When the size not the maximum, the unused SCM address range returns the value of the register ETPUSCMOFFDATAR.
- ⁴ SCM access is available only when bit VIS=1 on register ETPUMCR, under certain conditions (see [Section 29.2.5.1, ETPUMCR - eTPU Module Configuration Register](#)). SCM can only be written in 32 bit accesses.

29.2.5 System Configuration Registers

29.2.5.1 ETPUMCR - eTPU Module Configuration Register

In the eTPUA/B module, this register is shared between eTPU A and eTPU B engines.. ETPUMCR gathers configuration and status in the eTPU system, including a Global Exception. It is also used for configuring the SCM (Shared Code Memory) operation and test.

Base + 0x000

| | | | | | | | | | | | | | | | | |
|--------|-----|---|-----------|-----------|----------|----------|------|------|---|---|----|---------|----|----|----|----|
| | 0 | 1 | 2 | 3 | 4 | 5 | 6 | 7 | 8 | 9 | 10 | 11 | 12 | 13 | 14 | 15 |
| R | 0 | 0 | WDTO 1 | WDTO 2 | MGE 1 | MGE 2 | ILF1 | ILF2 | 0 | 0 | 0 | SCMSIZE | | | | |
| W | GEC | | | | | | | | | | | | | | | |
| RESET: | 0 | 0 | 0 | 0 | 0 | 0 | 0 | 0 | 0 | 0 | 0 | SCMSIZE | | | | |

| | | | | | | | | | | | | | | | | |
|--------|----|----|----|----|------------------|-------------|------------------|----|----|-----|----|----|----|----|----|------|
| | 16 | 17 | 18 | 19 | 20 | 21 | 22 | 23 | 24 | 25 | 26 | 27 | 28 | 29 | 30 | 31 |
| R | 0 | 0 | 0 | 0 | SCM MISC | SCM MISF | SCM MISE N | 0 | 0 | VIS | 0 | 0 | 0 | 0 | 0 | GTBE |
| W | | | | | SCM MISC C | | | | | | | | | | | |
| RESET: | 0 | 0 | 0 | 0 | 0 | 0 | 0 | 0 | 0 | 0 | 0 | 0 | 0 | 0 | 0 | 0 |

= Unimplemented or Reserved

Figure 29-3. ETPUMCR Register

GEC— Global Exception Clear

This write-only bit negates Global Exception request and clears Global Exception status bits MGE1, MGE2, ILF1, ILF2 and SCMMISF.

- 1 = Negate Global Exception, clear status bits ILF1, ILF2, MGE1, MGE2, and SCMMISF.
- 0 = Keep Global Exception request and status bits ILF1, ILF2, MGE1, MGE2, and SCMMISF as is.

GEC works the same way with either one or both Engines in Module Disable Mode.

WDTO1,2 — Watchdog Timeout

Flags WDTO1 and WDTO2 indicate that a Watchdog Timeout occurred in eTPU engine A or C and eTPU engine B respectively, generating a Global Exception. These bits are cleared by writing 1 to GEC.

- 1 = Global Exception requested by Watchdog timeout
- 0 = No Global Exception pending because of Watchdog timeout.

MGE1,2— Microcode Global Exception - Engine A, B

These bits indicate that a Global Exception was asserted by microcode executed on the respective Engine. The determination of the reason why the Global Exception was asserted is application dependent: it can be coded in an SDM status parameter, for instance. This bit is cleared by writing 1 to GEC.

- 1 = Global Exception requested by microcode is pending
- 0 = No microcode-requested Global Exception pending.

ILF1,2— Illegal Instruction Flag - eTPU A, B

The ILF1/2 bit is set by the microengine to indicate that an illegal instruction was decoded in Engine 1/2. This bit is cleared by host writing 1 to GEC. See the *eTPU Reference Manual* for more details.

- 1 = Illegal Instruction detected by eTPU A, B.
- 0 = Illegal Instruction not detected.

SCMSIZE[0:4] - SCM Size

This read-only field holds the number of 2 Kbyte SCM Blocks minus 1. This value is 11 for eTPU A/B and 5, meaning SCM sizes of 24 Kbyte, respectively.

SCMMISC, SCMMISCC — SCM MISC Complete, SCM MISC Complete Clear

Flag SCMMISC indicates that MISC has completed the evaluation of the SCM signature since reset or the since the last time it was cleared. SCMMISC is cleared by writing 1 to SCMMISCC (at same bit position), and is not cleared when MISC is disabled (SCMMISEN=0). SCMMISC asserts at the end of the SCM memory scan, either if the signature matches or not.

- 1 = MISC completed at least one SCM signature calculation and compare since the last time SCMMISC was cleared.
- 0 = MISC has not yet completed an SCM signature calculation and compare since the last time SCMMISC was cleared.

SCMMISF— SCM MISC Flag

The SCMMISF bit is set by the SCM MISC (Multiple Input Signature Calculator) logic to indicate that the calculated signature does not match the expected value, at the end of a MISC iteration. See [Section 29.3.6.1, SCM Test - Multiple Input Signature Calculator](#), for more details.

- 1 = MISC has read entire SCM array and the expected signature in ETPUMISCCMPR does not match the value calculated.

0 = Signature mismatch not detected.

This bit is cleared when Global Exception is cleared by writing 1 to GEC.

SCMMISEN — SCM MISC Enable

The SCMMISEN bit is used for enabling/disabling the operation of the MISC logic. SCMMISEN is readable and writable at any time. The MISC logic will only operate when this bit is set to 1. When the bit is reset the MISC address counter is set to the initial SCM address. When enabled, the MISC will continuously cycle through the SCM addresses, reading each and calculating a CRC. In order to save power, the MISC can be disabled by clearing the SCMMISEN bit. See [Section 29.3.6.1, SCM Test - Multiple Input Signature Calculator](#), for more details.

1 = MISC operation enabled.

0 = MISC operation disabled. The MISC logic is reset to its initial state.

SCMMISEN resets automatically when MISC logic detects an error, i.e., when SCMMISF transitions from 0 to 1, disabling the MISC operation.

VIS — SCM Visibility Bit

VIS bit turns SCM visible to the IP-Bus and resets MISC state (but SCMMISEN keeps its value).

1 = SCM is visible to the slave bus. MISC state is reset.

0 = SCM is not visible to the slave bus. Accessing SCM address space issues a bus error, writes are protected and reads are meaningless.

This bit is write protected when any of the Engines is not halted or stopped¹. When VIS=1, the ETPUECR MDIS bits are write protected. The value written to SCM is unspecified if other transfer sizes are used.

GTBE - Global Time Base Enable

GTBE enables time bases in both Engines, allowing them to be started synchronously.

1 = time bases in both Engines are enabled to run.

0 = time bases in both Engines are disabled to run.

NOTE

Global Time Base Enable action may also depend on other blocks, as explained in [Section 29.3.5.4, GTBE - Global Time Base Enable](#).

NOTE

When GTBE is turned off with Angle Mode enabled, the EAC must be reinitialized before GTBE is turned on again. The EAC reinitialization procedure is described in the *eTPU Reference Manual*.

1. Engine is stopped in Module Disable or Stop Modes.

29.2.5.2 ETPUCDCR - eTPU Coherent Dual-Parameter Controller Register

ETPUCDCR configures and controls dual-parameter coherent transfers. For more info, see [Section 29.3.4.2, Coherent Dual-parameter Controller - CDC](#).

Base + 0x004

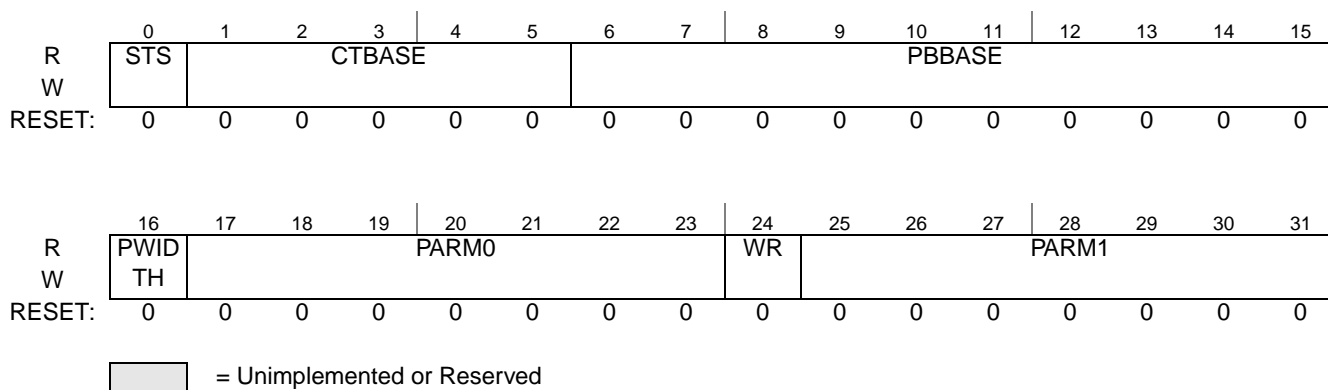

Figure 29-4. ETPUCDCR Register

STS — Start Bit

This bit is set by the host in order to start the data transfer between the parameter buffer pointed by PBBASE and the target addresses selected by the concatenation of fields CTBASE and PARM0/1. The host receives wait-states until the data transfer is complete, when this bit is reset by the coherency logic (see [Section 29.3.4.2, Coherent Dual-parameter Controller - CDC](#)). Therefore, host always reads STS as 0.

- 1 = (write) starts a coherent transfer.
- 0 = (write) does not start a coherent transfer.

CTBASE[0:4] — Channel Transfer Base

This field concatenates with fields PARM0/PARM1 to determine the absolute word offset (from the SDM base) of the parameters to be transferred:

$$\text{Parameter 0 word address} = \{\text{CTBASE, PARM0}\} + \text{SDM base word address}$$

$$\text{Parameter 1 word address} = \{\text{CTBASE, PARM1}\} + \text{SDM base word address}$$

PBBASE[0:9] — Parameter Buffer Base Address

This field points to the base address of the parameter buffer location, with granularity of 2 parameters (8 bytes). The host (byte) address of the first parameter in the buffer is $\text{PBBASE} * 8 + \text{SDM Base Byte Address}$. The microengine absolute (word) address of the first parameter in the buffer is $\text{PBBASE} * 2$.

PWIDTH — Parameter Width Selection

This bit selects the width of the parameters to be transferred between the PB and the target address.

- 1 = Transfer 32-bit parameters. All 32 bits of the parameters are written in the destination address.
- 0 = Transfer 24-bit parameters. The upper byte remains unchanged in the destination address.

WR — Read/Write selection

This bit selects the direction of the coherent data transfer.

1 = Write operation. Data transfer is from the PB to the selected SDM address.

0 = Read operation. Data transfer is from the selected SDM address to the PB.

PARM0[0:6], PARM1[0:6] — Channel Parameter number 0/number 1

These fields in concatenation with CTBASE[0:4] determine the word address offset (from the SDM base) of the parameters that are destination or source (defined by WR) of the coherent transfer. The word SDM address offset of the parameters are {CTBASE, PARM0/1}. Note that PARM0 and PARM1 allow non-contiguous parameters to be transferred coherently. The parameter pointed by {CTBASE, PARM0} is the first transferred.

29.2.5.3 ETPUMISCCMPR - eTPU MISC Compare Register

ETPUMISCCMPR holds the 32-bit signature expected from the whole SCM array. This register must be written by the host with the 32-bit word to be compared against the calculated signature at the end of the MISC cycle. This register is global to both eTPU Engines. For more detail see [Section 29.3.6.1, SCM Test - Multiple Input Signature Calculator](#).

Base + 0x00C

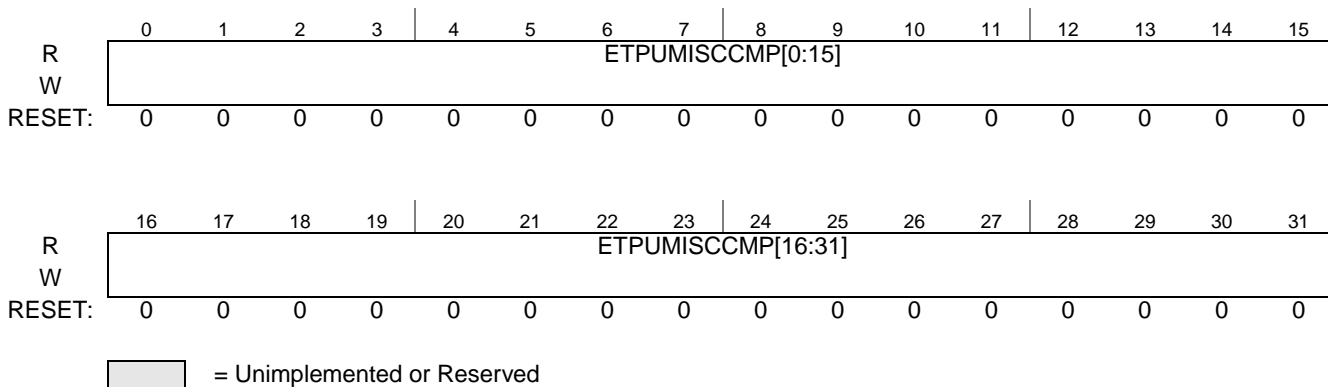

Figure 29-5. ETPUMISCCMPR Register

ETPUMISCCMP[0:31] — Expected Multiple Input Signature Register value

See [Section 29.3.6.1, SCM Test - Multiple Input Signature Calculator](#).

29.2.5.4 ETPUSCMOFFDATAR - eTPU SCM Off-range Data Register

ETPUSCMOFFDATAR holds the 32-bit value returned when SCM array is accessed at non implemented addresses, either by the Host or by the microengine. This register can be written by the host with the 32-bit instruction to be executed by the microengine to recover from runaway code. This register is global to both eTPU Engines. The reset value is . For more detail see [Section 29.3.2.6.3, SCM Off-range Data](#).

Base + 0x010

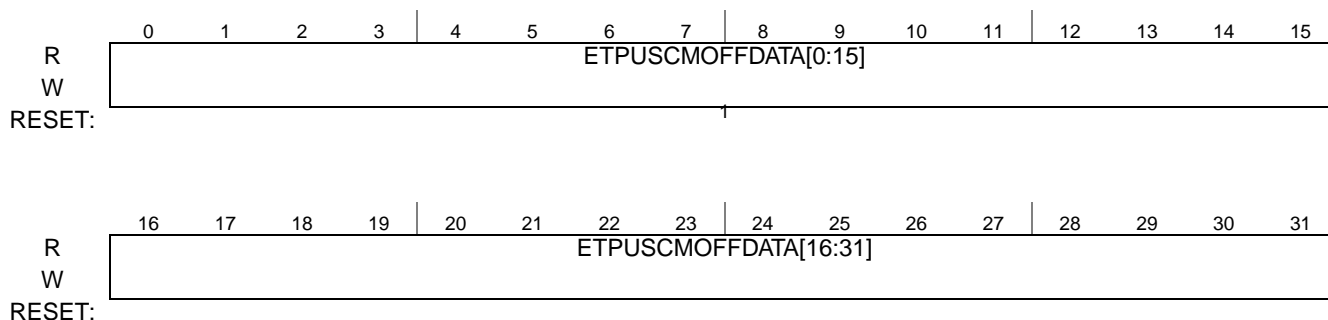

= Unimplemented or Reserved

¹ The reset value is 0xf3775ffb, an instruction that clears MRLEs, MRLs and TDLs, disables channel service requests, ends the thread and generates an illegal instruction Global Exception.

Figure 29-6. ETPUSCMOFFDATAR Register

ETPUSCMOFFDATA[0:31] — SCM Off-range read data value

See [Section 29.3.2.6.3, SCM Off-range Data](#).

29.2.5.5 ETPUECR - eTPU Engine Configuration Register

Each Engine has its own ETPUECR register. ETPUECR holds configuration and status fields that are programmed independently in each Engine.

eTPU A: Base + 0x014 / eTPU B: Base + 0x018

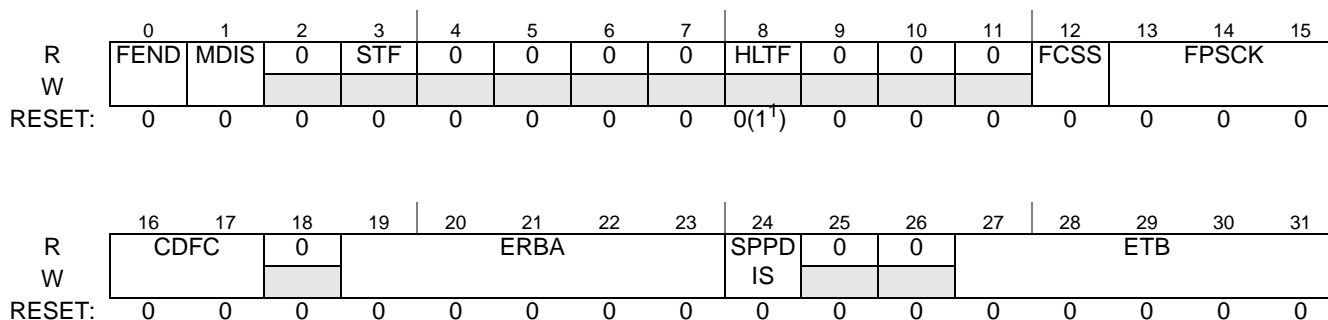

= Unimplemented or Reserved

¹ Engine may go to Debug state (halted) soon after reset, depending on the NDEDI configuration (see NDEDI Block Guide).

Figure 29-7. ETPUECR Register

FEND — Force End

FEND assertion terminates any current running thread as if an END instruction have been executed (see *eTPU Reference Manual* for details).

- 1 = Ends any ongoing thread.
- 0 = Normal operation.

This bit is self-negating when the thread ends¹. Writing FEND=1 is ignored and FEND stays 0 when the microengine is in TST, halted, stopped, or idle (no thread executing).

MDIS — Module Disable Bit

When MDIS is set, the Engine shuts down its internal clocks, going into Module Disable Mode. TCR1 and TCR2 cease to increment, and input sampling stops. The Engine asserts the stop flag (STF) bit to indicate that it has stopped. However, the BIU continues to run, and the Host can access all registers except for the channel registers² (see list of channel registers on [Section 29.2.10, Channel Configuration and Control Registers](#)). After MDIS is set, even before STF asserts, data read from the channel registers is not meaningful and writes are ineffective, issuing a Bus Error. When the MDIS bit is asserted while the microcode is executing, the eTPU will stop when the thread is complete.

- 1 = Commands Engine to stop its clocks.
- 0 = eTPU Engine runs.

Stop completes on the next eTPU clock after the stop condition is valid. The MDIS bit is write-protected when VIS=1.

NOTE

Once MDIS is switched from 1 to 0 or vice versa, it must not be written a different value until STF changes accordingly.

STF — Stop Flag Bit

Each Engine asserts its stop flag (STF) to indicate that it has stopped. Only then the host can assume that the Engine has actually stopped. The eTPU system is fully stopped when the STF bits of both eTPU Engines are asserted. In case of IP-Bus stop, the eTPU system responds by acknowledging stop only after both eTPU 1 and eTPU 2 have been stopped. Engine only stops when any ongoing thread is complete also in this case.

- 1 = Engine has stopped (after the local MDIS bit has been asserted, or after the IP-Bus stop line has been asserted).
- 0 = Engine is operating.

Summarizing Engine stop conditions, which STF reflects:

STF_1 := (after stop completed) MDIS_1 | device stop request

STF_2 := (after stop completed) MDIS_2 | device stop request

STF_1 and STF_2 mean STF bit from engine 1 and STF bit from engine 2 respectively.

HLTF — Halt Mode Flag

1. Only on rare occasions (e.g., during a long stall, (see *eTPU Reference Manual*) FEND can be read as 1, because it negates as soon as the end begins execution.
2. The Timebase registers can still be read with MDIS=1, but writes are ineffective and a Bus Error is issued. Global Channel Registers and SDM can be accessed normally.

If eTPU Engine entered halt state, this flag is asserted. The flag remains asserted while the microengine is in halt state, even during a single-step or forced instruction execution..

- 1 = eTPU Engine is halted
- 0 = eTPU Engine is not halted.

FCSS - Filter Clock Source Selection

Speeds up the filter clock source before the prescaler, allowing more input capture resolution at minimum prescaling.

- 1 = use eTPU clock as EDF clock source before prescaler
- 0 = use eTPU clock / 2 as EDF clock source before prescaler.

NOTE

FCSS=1 also makes the channel work on T2/T4 timing mode (see *eTPU Reference Manual*).

FPSCK[0:2] — Filter Prescaler Clock Control

FPSCK controls the prescaling of the clocks used in digital filters for the channel input signals and TCRCLK input, as shown in [Table 29-6](#). Filtering can be controlled independently by Engine, but all input digital filters in the same Engine have same clock prescaling. For more details see [Section 29.3.4.4.5, Filter Clock Prescaler](#).

Table 29-6. Filter Prescaler Clock Control

| Filter Control | Sample on eTPU clock Divided by: |
|----------------|----------------------------------|
| 000 | 2 |
| 001 | 4 |
| 010 | 8 |
| 011 | 16 |
| 100 | 32 |
| 101 | 64 |
| 110 | 128 |
| 111 | 256 |

A new value written to FPSCK only becomes effective when the filter prescaler finishes the current count.

CDFC[0:1] — Channel Digital Filter Control

These bits select a digital filtering mode for the channels when configured as inputs for improved noise immunity (refer to [Table 29-7](#)). The eTPU has three digital filtering modes for the channels which provide programmable trade-off between signal latency and noise immunity (see [Section 29.3.4.4, Enhanced Digital Filter - EDF](#)). Changing CDFC during eTPU normal input channel operation is not recommended since it changes the behavior of the transition detection logic while executing its operation.

Table 29-7. Channel Digital Filter Control

| CDFC | Selected Digital Filter |
|------|--|
| 00 | TPU2/3 Two Sample Mode: Using the filter clock which is the eTPU clock divided by (2, 4, 8,..., 256) as a sampling clock (selected by FPSCK field in ETPUECR), comparing two consecutive samples which agree with each other sets the input signal state. This is the default reset state. |
| 01 | eTPU bypass mode: the input signal is taken unfiltered, also making the channels work on T2/T4 timing mode ¹ . |
| 10 | eTPU Three Sample Mode: Similar to the TPU2/3 two sample mode, but comparing three consecutive samples which agree with each other sets the input signal state. |
| 11 | eTPU Continuous Mode: Signal need to be stable for the whole filter clock period. This mode compares all the values at the rate of eTPU clock (FCSS=1) or eTPU clock divided by two (FCSS=0), between two consecutive filter clock pulses. Signal needs to be continuously stable for the entire period. If all the values agree with each other, input signal state is updated. |

¹ See *eTPU Reference Manual*

ERBA — Engine Relative Base Address

This field value is concatenated with the AID instruction field in engine relative address mode to form the SDM address (see *eTPU Reference Manual*).

SPPDIS — Schedule Priority Passing Disable

SPPDIS is used to disable the priority passing mechanism of the microengine scheduler (see [Section 29.3.3.2.1, Primary Scheme - Priority Among Channels on Different Levels](#)).

1 = Scheduler priority passing mechanism disabled.

0 = Scheduler priority passing mechanism enabled.

NOTE

SPPDIS bit must not be changed while any channel is enabled.

ETB[0:4] — Entry Table Base

The field determines the location of the microcode entry table for the eTPU functions in SCM (see *eTPU Reference Manual* for details of how to use this field).

29.2.6 Time Base Registers

Time Base registers allows configuration and visibility of internally-generated time bases TCR1 and TCR2. There is one of each of these registers for each eTPU Engine.

NOTE

Writes to this register issue bus error and are ineffective when MDIS=1.

Reads are always allowed.

29.2.6.1 ETPUTBCR - eTPU Time Base Configuration Register

This register configures several timebase options.

eTPU A: Base + 0x020 / eTPU B: Base + 0x040

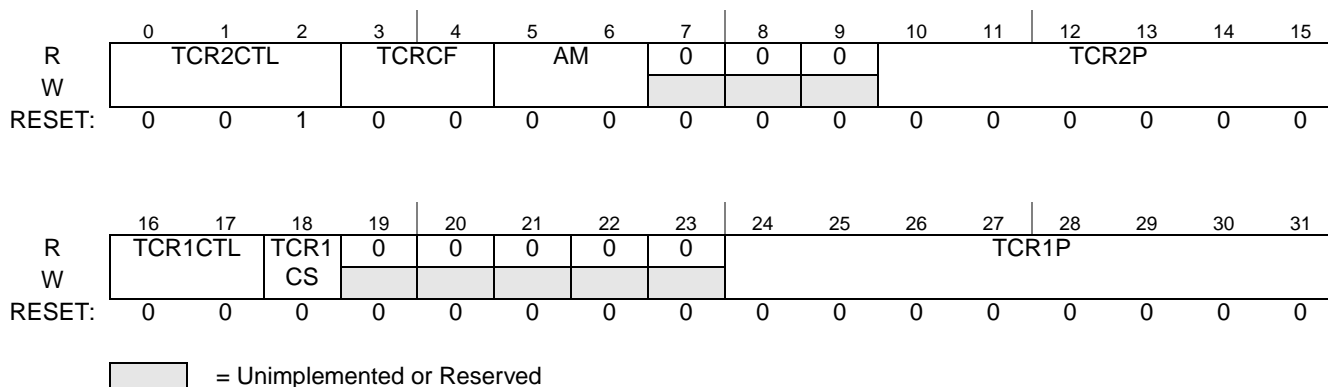

Figure 29-8. ETPUTBCR Register

TCR2CTL[0:2] — TCR2 Clock/Gate Control

These bits are part of the TCR2 clocking system (see Section 29.3.5, Time Bases). They determine the clock source for TCR2 before the prescaler. TCR2 can count on any detected edge of the TCRCLK signal or use it for gating eTPU clock divided by 8. After reset - TCRCLK signal rising edge is selected. TCR2 can also be clocked by the eTPU clock divided by 8. TCR2CTL also determines the TCRCLK edge selected for angle tooth detection in angle mode. See Table 29-8.

Table 29-8. TCR2 Clock Source

| TCR2CTL | AM = 0 TCR2 Clock before prescaler | AM = 1 Angle Tooth detection |
|---------|---|---------------------------------|
| 000 | Gated DIV8 clock (eTPU clock / 8). In this case, when the external TCRCLK signal is low, the DIV8 clock is blocked, preventing it from incrementing the TCR2 prescaler. When the external TCRCLK signal is high, TCR2 prescaler is incremented at the frequency of the eTPU clock divided by 8. | do not use with AM=1 |
| 001 | Rise transition on TCRCLK signal increments the TCR2 prescaler. | rise edge |
| 010 | Fall transition on TCRCLK signal increments the TCR2 prescaler. | fall edge |
| 011 | Rise or Fall transition on TCRCLK signal increments the TCR2 prescaler. | both edges |
| 100 | DIV8 clock (eTPU clock / 8) | do not use with AM=1 |
| 101 | do not use with AM=0 | no edge ¹ |
| 110 | | |
| 111 | TCR2 frozen, except as STAC client | do not use with AM=1 |

¹ TCRCLK edges are not detected by the EAC logic, but they can still be detected by the channel 0 logic if AM=01.

TCRCF[0:1] — TCRCLK Signal Filter Control

This field controls the TCRCLK digital filter (see [Section 29.3.5.5, TCRCLK Digital Filter](#)), determining whether the TCRCLK signal input (after a synchronizer) is filtered with the same filter clock as the channel input signals (see [Section 29.3.4.4, Enhanced Digital Filter - EDF](#)) or uses the eTPU clock divided by 2, and also whether the TCRCLK digital filter works in integrator mode or two sample mode (see [Table 29-9](#)).

Table 29-9. TCRCLK Filter Clock/Mode

| TCRCF | Filter Clock | Filter Mode |
|-------|------------------------------|-------------|
| 00 | eTPU clock divided by 2 | two sample |
| 01 | filter clock of the channels | two sample |
| 10 | eTPU clock divided by 2 | integrator |
| 11 | filter clock of the channels | integrator |

AM — Angle Mode Selection

This field enables the Enhanced Angle Counter logic to generate angle information (see *eTPU Reference Manual* for details), and also select the tooth signal input and the channel used to process it, as shown in [Table 29-10](#). When EAC is not disabled by AM and neither TCR1 nor TCR2 are STAC Clients, the EAC (eTPU Angle Clock) hardware provides angle information to the channels using the TCR2 bus. When AM is reset (non-angle mode), the EAC operation is disabled, and its internal registers can be used as general purpose. For more information, see *eTPU Reference Manual*.

Table 29-10. AM - Angle Mode Selection

| Value | TCR2 Value | Tooth signal | Tooth processing channel |
|-------|-----------------------------------|-----------------|--------------------------|
| 0 0 | Timebase (EAC operation disabled) | not applicable | |
| 0 1 | Angle Ticks | TCRCLK input | 0 |
| 1 0 | | channel 1 input | 1 |
| 1 1 | | channel 2 input | 2 |

If TCR1 or TCR2 is a STAC Bus Client (see [Section 29.3.5.3, STAC Interface](#)), the EAC operation is not allowed, and if AM is set the Angle Logic does not work properly.

NOTE

Changing AM may cause spurious transition detections on the channel selected by AM, depending on the channel mode and state (see *eTPU Reference Manual* for details). If AM must be changed with GTBE=1, the recommended procedure is described in the *eTPU Reference Manual*.

TCR2P[0:5] — Timer Count Register 2 Prescaler Control

These bits are part of the TCR2 clocking system (see [Section 29.3.5, Time Bases](#)). TCR2 is clocked from the output of a prescaler. The prescaler divides its input by (TCR2P+1) allowing frequency divisions from 1 to 64. The prescaler input is the eTPU clock divided by 8 (in gated or non-gated clock mode), or Internal Timebase input, or TCRCLK filtered input. This field has no effect on TCR2 in Angle Mode.

TCR1CTL[0:1] — TCR1 Clock/Gate Control

TCR1CTL is part of the TCR1 clocking system (see [Section 29.3.5, Time Bases](#)). It determines, together with TCR1CS, the clock source for TCR1. TCR1 can count on detected rising edge of the TCRCLK signal, the eTPU clock, or the eTPU clock divided by 2 (see [Table 29-11](#)). After reset TCRCLK signal is selected

TCR1CS - TCR1 Clock Source

TCR1CS provides the option to double the TCR1 incrementing speed, using eTPU clock as its clock source instead of eTPU clock / 2.

- 1 = use eTPU clock as TCR1 clock source before the prescaler; can only be set in specific combinations with TCR1CTL (see [Table 29-11](#)).
- 0 = use eTPU clock / 2 as TCR1 clock source before the prescaler, if that clock source is selected by TCR1CTL.

NOTE

TCR1CS=1 also makes the channel work on T2/T4 timing mode (see *eTPU Reference Manual* for details).

NOTE

The clock source of the EAC angle tick generator will still be an even division of eTPU clock if TCR1CS=1, obeying to the fields TCR1P as if TCR1CS=0 (see *eTPU Reference Manual* for details).

Table 29-11. TCR1 Clock Source

| TCR1CTL | TCR1CS ¹ | TCR1 Clock before prescaler |
|---------|---------------------|--|
| 00 | 0 | selects TCRCLK as clock source for the TCR1 prescaler ² |
| 10 | 0 | selects eTPU clock divided by 2 as clock source for the TCR1 prescaler |
| 10 | 1 | selects eTPU clock as clock source for the TCR1 prescaler |
| 11 | 0 | TCR1 frozen, except as a STAC client; |

¹ All other combinations of TCR1CTL and TCR1CS are reserved.

² This selection must not be used in Angle Mode.

TCR1P[0:7] — Timer Count Register 1 Prescaler Control

TCR1 is clocked from the output of a prescaler. The input to the prescaler is the internal eTPU clock divided by 2, eTPU clock, or the output of TCRCLK filter. The prescaler divides this input by (TCR1P+1) allowing frequency divisions from 1 up to 256.

29.2.6.2 ETPUTB1R - eTPU Time Base 1 (TCR1) Visibility Register

This register provides visibility of the TCR1 time base for host read access (see [Section 29.3.5, Time Bases](#)). This register is read-only. The value of the TCR1 time base shown can be driven by the TCR1 counter or imported from STAC bus, depending on the configuration set in ETPUREDCCR.

eTPU A: Base + 0x024 / eTPU B: Base + 0x044

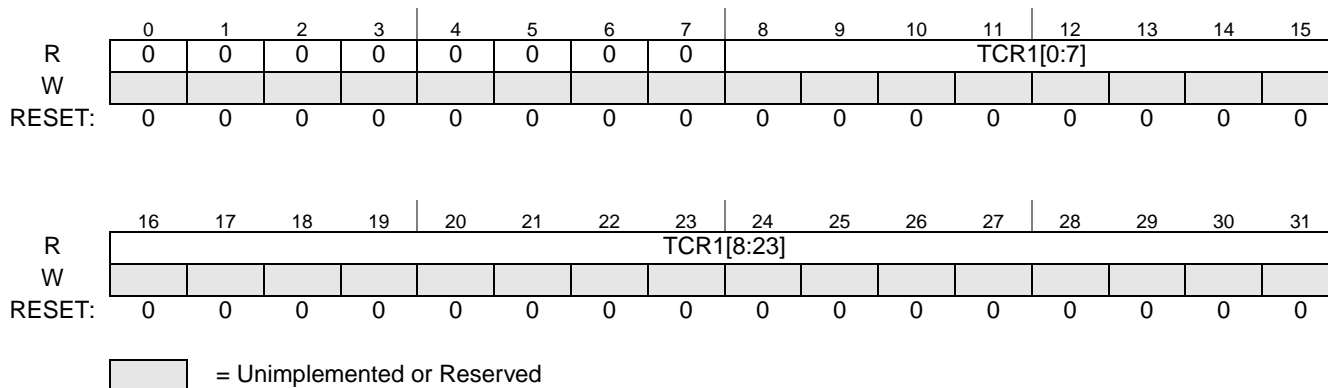

Figure 29-9. ETPUTB1R Register

TCR1[0:23] — TCR1 value

TCR1 value used on matches and captures. See [Section 29.3.5, Time Bases](#).

29.2.6.3 ETPUTB2R - eTPU Time Base 2 (TCR2) Visibility Register

This register provides visibility of the TCR2 time base for host read access (see [Section 29.3.5, Time Bases](#)). This register is read-only. The value of the TCR2 time base shown can be driven by the TCR2 counter, the Angle Mode logic, or imported from STAC, depending on Angle Mode and STAC configurations set in registers ETPUTBCR and ETPUREDCCR.

eTPU A: Base + 0x028 / eTPU B: Base + 0x048

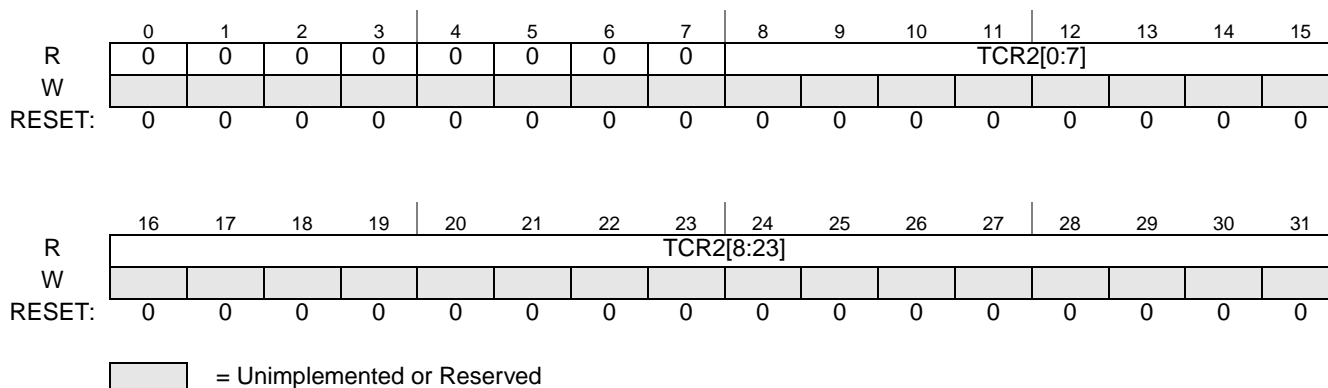

Figure 29-10. ETPUTB2R Register

TCR2[0:23] — TCR2 value

TCR2 value used on matches and captures. See [Section 29.3.5, Time Bases](#).

29.2.6.4 ETPUREDCCR - eTPU STAC Configuration Register

This register configures the eTPU STAC bus operation as a STAC Server/Client module (see [Section 29.3.5.3, STAC Interface](#)).

eTPU A: Base + 0x02C / eTPU B: Base + 0x04C

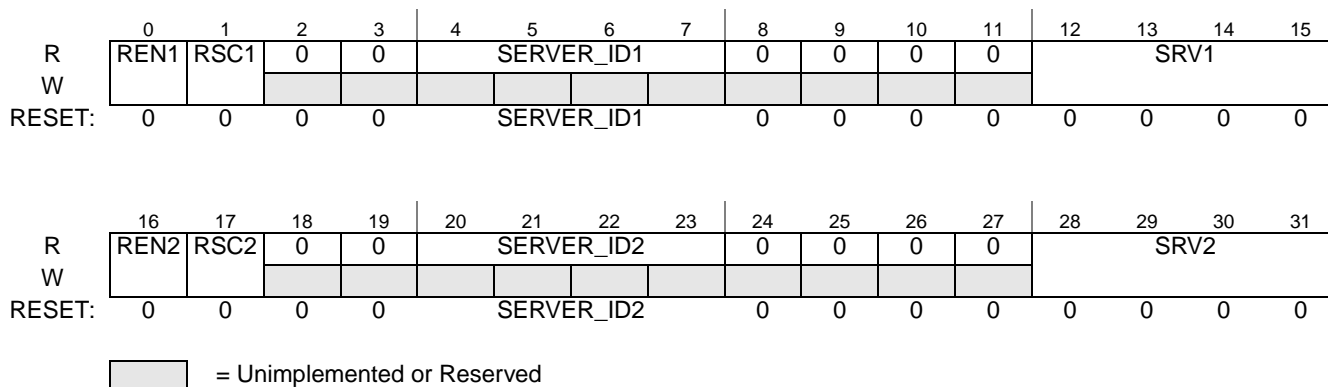

Figure 29-11. ETPUREDCCR Register

REN1,2 — TCR1/2 Resource¹ Client/Server Operation Enable Bits

These bits enable or disable Client/Server operation to eTPU STAC resources. REN1 enables TCR1 and REN2 enables TCR2 STAC bus operations.

- 1 = Server/Client Operation for resource 1/2 is enabled.
- 0 = Server/Client Operation for resource 1/2 is disabled.

RSC1,2 — TCR1/2 Resource Server/Client Assignment Bits

These bits select the eTPU data resource assignment to be used as Servers or Clients. RSC1 selects the functionality of TCR1 and RSC2 selects the functionality of TCR2. For Server mode, external plugging determines the unique server address assigned to each TCR. For a Client mode, the SRV1 and SRV2 fields determine the Server address to which the Client listens.

- 1 = Resource Server operation.
- 0 = Resource Client operation.

NOTE

When TCR1 or TCR2 is configured as a STAC Bus Client (REN2=1, RSC2=0) the eTPU Angle Clock hardware cannot be used.

NOTE

RSC1,2 must not be changed when the respective REN1,2 bit is asserted.

SERVER_ID1,2 — STAC Ids 1,2

STAC Server Ids (read-only plug values) used for TCR1 and TCR2, respectively, when STAC servers.

1. **resource** identifies any parameter that changes along the time and can be exported / imported from other device. In eTPU context, a resource can be TCR1 or TCR2 (either Time or Angle values).

SRV1,2 — TCR1/2 Resource Server

These bits select the address of the specific STAC Server to which the local TCR1 or TCR2 listens when configured as a STAC Client. SRV1 and SRV2 select the STAC Server of TCR1 and TCR2, respectively.

29.2.7 Engine Related Registers

This section gathers registers that are engine-related, other than ETPUECR (see [Section 29.2.5.5, ETPUECR - eTPU Engine Configuration Register](#)).

29.2.7.1 ETPUWDTR - eTPU Watchdog Timer Register

This register configures the watchdog timer for the engine.

eTPU A: Base + 0x060 / eTPU B: Base + 0x070

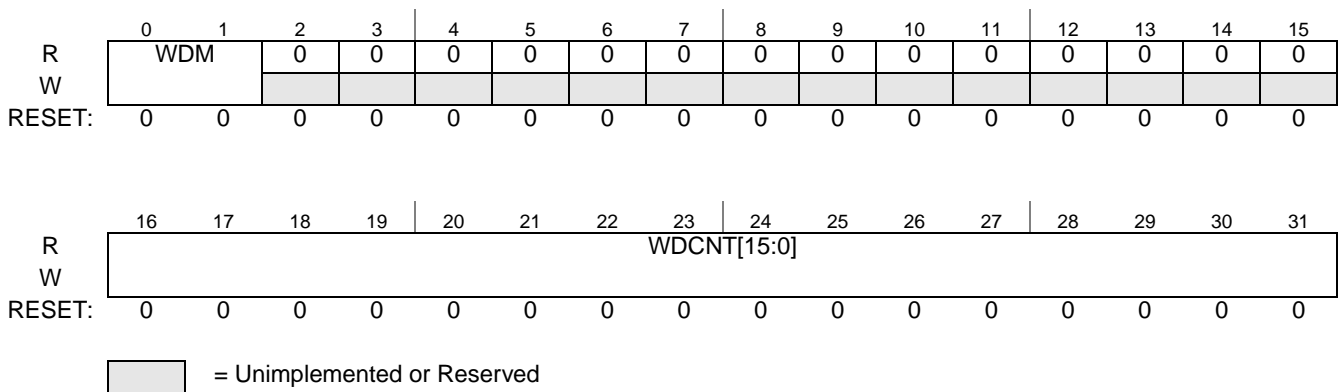

Figure 29-12. ETPUWDTR Register

WDM — Watchdog Mode

WDM selects the Watchdog operation mode, as shown in [Table 29-12](#). For more information on the Watchdog operation, see [Section 29.3.1, Watchdog](#).

Table 29-12. WDM - Watchdog Mode

| Value | Watchdog Mode |
|-------|---------------|
| 0 0 | disabled |
| 0 1 | reserved |
| 1 0 | thread length |
| 1 1 | busy length |

NOTE

Before a new mode is configured, all conditions below must apply:

- 1- all channels must be disabled (ETPUCxCR field CPR=00).
- 2- no thread must be executing (register ETPUCSSR reads 0).
- 3- the watchdog must be disabled (WDM=00).

WDCNT[15:0] — Watchdog Count

This field indicates the maximum number of microcycles allowed for a thread (in thread length mode) or a sequence of threads (in busy length mode) before the current running thread is forced to end. For more information on Watchdog operation, see [Section 29.3.1, Watchdog](#).

NOTE

The TST microcycles are also counted by the watchdog.

29.2.7.2 ETPUIDLER - eTPU Idle Register

This register counts the microcycles in which the microengine is idle (see [Section 29.3.7.1, Idle Counter](#)).

eTPU A: Base + 0x068 / eTPU B: Base + 0x078

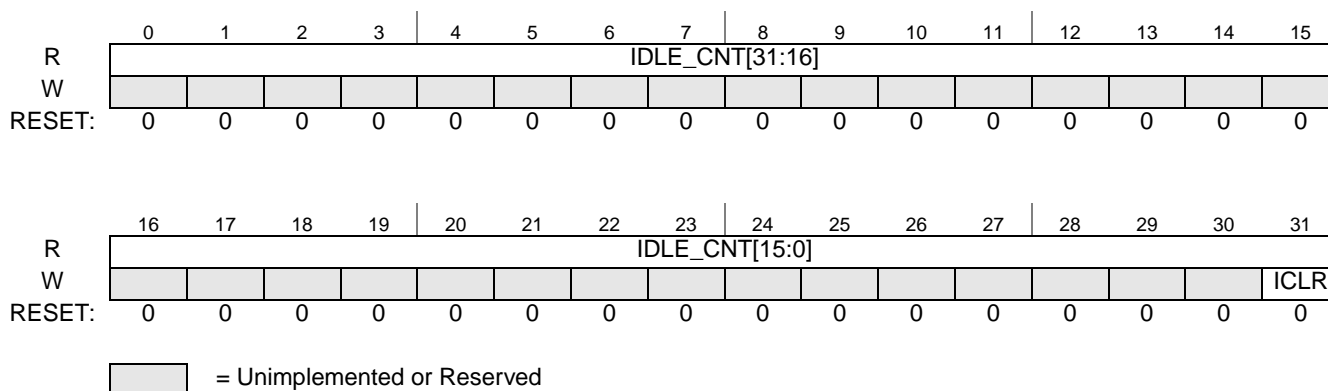

Figure 29-13. ETPUIDLER Register

IDLE_CNT[31:0] — Idle Count

This is a free-running count of the number of idle microcycles in the microengine. For more information on idle counter operation, see [Section 29.3.7.1, Idle Counter](#).

ICLR — Idle Clear

This write-only bit is used to clear the idle count IDLE_CNT:

- 1 = clear the idle count IDLE_CNT
- 0 = do not clear idle count IDLE_CNT

29.2.8 Channel Registers Layout

The channel registers area is shown in [Figure 29-14](#) and detailed in next sections, for eTPU systems of 32 channels per Engine. Reserved areas are placed to allow doubling the number of channels to 64 for each eTPU Engine.

| | |
|-------|----------------------------|
| 0x200 | Global Channel Registers |
| 0x26C | Reserved |
| 0x400 | Engine 1 Channel Registers |
| 0x600 | Reserved |
| 0x800 | Engine 2 Channel Registers |
| 0xA00 | Reserved |

Figure 29-14. Channel Registers Area

29.2.9 Global Channel Registers

The registers in this section group, by type, the interrupt status and enable bits from all the channels. This organization eases management of all channels or groups of channels by a single interrupt handler routine. These bits, except the service and watchdog status, are mirrored in the individual channel registers, grouped by channel.

29.2.9.1 ETPUCISR - eTPU Channel Interrupt Status Register

Host interrupt status (see [Section 29.3.2.2, Interrupts and Data Transfer Requests](#)) from all channels are grouped in ETPUCISR. Their bits are mirrored from the Channel Status/Control registers (see [Section 29.2.10, Channel Configuration and Control Registers](#)) and Host must write 1 to clear a status bit.

eTPU A: Base + 0x200 / eTPU B: Base + 0x204

| | | | | | | | | | | | | | | | | |
|--------|-----------|-----------|-----------|-----------|-----------|-----------|-----------|-----------|-----------|-----------|-----------|-----------|-----------|-----------|-----------|-----------|
| | 0 | 1 | 2 | 3 | 4 | 5 | 6 | 7 | 8 | 9 | 10 | 11 | 12 | 13 | 14 | 15 |
| R | CIS3 1 | CIS3 0 | CIS2 9 | CIS2 8 | CIS2 7 | CIS2 6 | CIS2 5 | CIS2 4 | CIS2 3 | CIS2 2 | CIS2 1 | CIS2 0 | CIS1 9 | CIS1 8 | CIS1 7 | CIS1 6 |
| W | CIC3 1 | CIC3 0 | CIC2 9 | CIC2 8 | CIC2 7 | CIC2 6 | CIC2 5 | CIC2 4 | CIC2 3 | CIC2 2 | CIC2 1 | CIC2 0 | CIC1 9 | CIC1 8 | CIC1 7 | CIC1 6 |
| RESET: | 0 | 0 | 0 | 0 | 0 | 0 | 0 | 0 | 0 | 0 | 0 | 0 | 0 | 0 | 0 | 0 |

| | | | | | | | | | | | | | | | | |
|--------|-----------|-----------|-----------|-----------|-----------|-----------|------|------|------|------|------|------|------|------|------|------|
| | 16 | 17 | 18 | 19 | 20 | 21 | 22 | 23 | 24 | 25 | 26 | 27 | 28 | 29 | 30 | 31 |
| R | CIS1 5 | CIS1 4 | CIS1 3 | CIS1 2 | CIS1 1 | CIS1 0 | CIS9 | CIS8 | CIS7 | CIS6 | CIS5 | CIS4 | CIS3 | CIS2 | CIS1 | CIS0 |
| W | CIC1 5 | CIC1 4 | CIC1 3 | CIC1 2 | CIC1 1 | CIC1 0 | CIC9 | CIC8 | CIC7 | CIC6 | CIC5 | CIC4 | CIC3 | CIC2 | CIC1 | CIC0 |
| RESET: | 0 | 0 | 0 | 0 | 0 | 0 | 0 | 0 | 0 | 0 | 0 | 0 | 0 | 0 | 0 | 0 |

Figure 29-15. ETPUCISR Register

CISx — Channel x Interrupt Status

Enhanced Time Processing Unit (eTPU2)

- 1 = indicates that channel x has a pending interrupt to the Host CPU.
- 0 = indicates that channel x has no pending interrupt to the Host CPU.

CICx — Channel x Interrupt Clear

- 1 = clear interrupt status bit.
- 0 = keep interrupt status bit unaltered.

For details about interrupts see the *eTPU Reference Manual* for details.

29.2.9.2 ETPUCDTRSR - eTPU Channel Data Transfer Request Status Register

Data Transfer request status (see [Section 29.3.2.2, Interrupts and Data Transfer Requests](#)) from all channels are grouped in ETPUCDTRSR. Their bits are mirrored from the Channel Status/Control registers (see [Section 29.2.9.8, ETPUCSSR - eTPU Channel Service Status Register](#)).

eTPU A: Base + 0x210 / eTPU B: Base + 0x214

| | | | | | | | | | | | | | | | | |
|--------|------|------|------|------|------|------|------|------|------|------|------|------|------|------|------|------|
| | 0 | 1 | 2 | 3 | 4 | 5 | 6 | 7 | 8 | 9 | 10 | 11 | 12 | 13 | 14 | 15 |
| R | DTRS | DTRS | DTRS | DTRS | DTRS | DTRS | DTRS | DTRS | DTRS | DTRS | DTRS | DTRS | DTRS | DTRS | DTRS | DTRS |
| | 31 | 30 | 29 | 28 | 27 | 26 | 25 | 24 | 23 | 22 | 21 | 20 | 19 | 18 | 17 | 16 |
| W | DTR | DTR | DTR | DTR | DTR | DTR | DTR | DTR | DTR | DTR | DTR | DTR | DTR | DTR | DTR | DTR |
| | C | C | C | C | C | C | C | C | C | C | C | C | C | C | C | C |
| | 31 | 30 | 29 | 28 | 27 | 26 | 25 | 24 | 23 | 22 | 21 | 20 | 19 | 18 | 17 | 16 |
| RESET: | 0 | 0 | 0 | 0 | 0 | 0 | 0 | 0 | 0 | 0 | 0 | 0 | 0 | 0 | 0 | 0 |

| | | | | | | | | | | | | | | | | |
|--------|------|------|------|------|------|------|------|------|------|------|------|------|------|------|------|------|
| | 16 | 17 | 18 | 19 | 20 | 21 | 22 | 23 | 24 | 25 | 26 | 27 | 28 | 29 | 30 | 31 |
| R | DTRS | DTRS | DTRS | DTRS | DTRS | DTRS | DTRS | DTRS | DTRS | DTRS | DTRS | DTRS | DTRS | DTRS | DTRS | DTRS |
| | 15 | 14 | 13 | 12 | 11 | 10 | 9 | 8 | 7 | 6 | 5 | 4 | 3 | 2 | 1 | 0 |
| W | DTR | DTR | DTR | DTR | DTR | DTR | DTR | DTR | DTR | DTR | DTR | DTR | DTR | DTR | DTR | DTR |
| | C | C | C | C | C | C | C | C | C | C | C | C | C | C | C | C |
| | 15 | 14 | 13 | 12 | 11 | 10 | 9 | 8 | 7 | 6 | 5 | 4 | 3 | 2 | 1 | 0 |
| RESET: | 0 | 0 | 0 | 0 | 0 | 0 | 0 | 0 | 0 | 0 | 0 | 0 | 0 | 0 | 0 | 0 |

Figure 29-16. ETPUCDTRSR Register

DTRSx — Channel x Data Transfer Request Status

These bits mimic the corresponding ETPU DMA requests. DTRSx can be cleared by software (writing 1 to DTRCx) or by the assertion of corresponding DMA completion acknowledge line.

- 1 = indicates that channel x has a pending data transfer request.
- 0 = indicates that channel x has no pending data transfer request.

DTRCx — Channel x Data Transfer Request Clear

- 1 = clear status bit.
- 0 = keep status bit unaltered

For details about interrupts see the *eTPU Reference Manual* for details.

29.2.9.3 ETPUCIOSR - eTPU Channel Interrupt Overflow Status Register

Interrupt Overflow status (see [Section 29.3.2.2, Interrupts and Data Transfer Requests](#)) from all channels are grouped in ETPUCIOSR. Their bits are mirrored from the Channel Status/Control registers (see [Section 29.2.10.2, ETPUCxSCR - eTPU Channel x Status Control Register](#)) and one must write 1 to clear a status bit.

eTPU A: Base + 0x220 / eTPU B: Base + 0x224

| | | | | | | | | | | | | | | | | |
|--------|------|------|------|------|------|------|------|------|------|------|------|------|------|------|------|------|
| | 0 | 1 | 2 | 3 | 4 | 5 | 6 | 7 | 8 | 9 | 10 | 11 | 12 | 13 | 14 | 15 |
| R | CIOS | CIOS | CIOS | CIOS | CIOS | CIOS | CIOS | CIOS | CIOS | CIOS | CIOS | CIOS | CIOS | CIOS | CIOS | CIOS |
| | 31 | 30 | 29 | 28 | 27 | 26 | 25 | 24 | 23 | 22 | 21 | 20 | 19 | 18 | 17 | 16 |
| W | CIOC | CIOC | CIOC | CIOC | CIOC | CIOC | CIOC | CIOC | CIOC | CIOC | CIOC | CIOC | CIOC | CIOC | CIOC | CIOC |
| | 31 | 30 | 29 | 28 | 27 | 26 | 25 | 24 | 23 | 22 | 21 | 20 | 19 | 18 | 17 | 16 |
| RESET: | 0 | 0 | 0 | 0 | 0 | 0 | 0 | 0 | 0 | 0 | 0 | 0 | 0 | 0 | 0 | 0 |

| | | | | | | | | | | | | | | | | |
|--------|------|------|------|------|------|------|------|------|------|------|------|------|------|------|------|------|
| | 16 | 17 | 18 | 19 | 20 | 21 | 22 | 23 | 24 | 25 | 26 | 27 | 28 | 29 | 30 | 31 |
| R | CIOS | CIOS | CIOS | CIOS | CIOS | CIOS | CIOS | CIOS | CIOS | CIOS | CIOS | CIOS | CIOS | CIOS | CIOS | CIOS |
| | 15 | 14 | 13 | 12 | 11 | 10 | 9 | 8 | 7 | 6 | 5 | 4 | 3 | 2 | 1 | 0 |
| W | CIOC | CIOC | CIOC | CIOC | CIOC | CIOC | CIOC | CIOC | CIOC | CIOC | CIOC | CIOC | CIOC | CIOC | CIOC | CIOC |
| | 15 | 14 | 13 | 12 | 11 | 10 | 9 | 8 | 7 | 6 | 5 | 4 | 3 | 2 | 1 | 0 |
| RESET: | 0 | 0 | 0 | 0 | 0 | 0 | 0 | 0 | 0 | 0 | 0 | 0 | 0 | 0 | 0 | 0 |

Figure 29-17. ETPUCIOSR Register

CIOSt — Channel x Interrupt Overflow Status

- 1 = indicates that interrupt overflow occurred in the channel.
- 0 = indicates that no interrupt overflow occurred in the channel.

CIOCx — Channel x Interrupt Overflow Clear

- 1 = clear status bit.
- 0 = keep status bit unaltered.

For details about interrupt overflow, see [Section 29.3.2.2.2, Interrupt and Data Transfer Request Overflow](#).

29.2.9.4 ETPUCDTROSR - eTPU Channel Data Transfer Request Overflow Status Register

Data Transfer Request Overflow status (see [Section 29.3.2.2, Interrupts and Data Transfer Requests](#)) from all channels are grouped in ETPUCDTROSR. Their bits are mirrored from the Channel Status/Control registers (see [Section 29.2.10.2, ETPUCxSCR - eTPU Channel x Status Control Register](#)) and one must write 1 to clear a status bit.

eTPU A: Base + 0x230 / eTPU B: Base + 0x234

| | | | | | | | | | | | | | | | | |
|--------|-----------|-----------|-----------|-----------|-----------|-----------|-----------|-----------|-----------|-----------|-----------|-----------|-----------|-----------|-----------|-----------|
| | 0 | 1 | 2 | 3 | 4 | 5 | 6 | 7 | 8 | 9 | 10 | 11 | 12 | 13 | 14 | 15 |
| R | DTR OS 31 | DTR OS 30 | DTR OS 29 | DTR OS 28 | DTR OS 27 | DTR OS 26 | DTR OS 25 | DTR OS 24 | DTR OS 23 | DTR OS 22 | DTR OS 21 | DTR OS 20 | DTR OS 19 | DTR OS 18 | DTR OS 17 | DTR OS 16 |
| W | DTR OC 31 | DTR OC 30 | DTR OC 29 | DTR OC 28 | DTR OC 27 | DTR OC 26 | DTR OC 25 | DTR OC 24 | DTR OC 23 | DTR OC 22 | DTR OC 21 | DTR OC 20 | DTR OC 19 | DTR OC 18 | DTR OC 17 | DTR OC 16 |
| RESET: | 0 | 0 | 0 | 0 | 0 | 0 | 0 | 0 | 0 | 0 | 0 | 0 | 0 | 0 | 0 | 0 |

| | | | | | | | | | | | | | | | | |
|--------|-----------|-----------|-----------|-----------|-----------|-----------|----------|----------|----------|----------|----------|----------|----------|----------|----------|----------|
| | 16 | 17 | 18 | 19 | 20 | 21 | 22 | 23 | 24 | 25 | 26 | 27 | 28 | 29 | 30 | 31 |
| R | DTR OS 15 | DTR OS 14 | DTR OS 13 | DTR OS 12 | DTR OS 11 | DTR OS 10 | DTR OS 9 | DTR OS 8 | DTR OS 7 | DTR OS 6 | DTR OS 5 | DTR OS 4 | DTR OS 3 | DTR OS 2 | DTR OS 1 | DTR OS 0 |
| W | DTR OC 15 | DTR OC 14 | DTR OC 13 | DTR OC 12 | DTR OC 11 | DTR OC 10 | DTR OC 9 | DTR OC 8 | DTR OC 7 | DTR OC 6 | DTR OC 5 | DTR OC 4 | DTR OC 3 | DTR OC 2 | DTR OC 1 | DTR OC 0 |
| RESET: | 0 | 0 | 0 | 0 | 0 | 0 | 0 | 0 | 0 | 0 | 0 | 0 | 0 | 0 | 0 | 0 |

Figure 29-18. ETPUCDTROSR Register

DTROSR_x — Channel x Data Transfer Request Overflow Status

- 1 = indicates that data transfer request overflow occurred in the channel.
- 0 = indicates that no data transfer request overflow occurred in the channel.

DTROC_x — Channel x Data Transfer Request Overflow Clear

- 1 = clear status bit.
- 0 = keep status bit unaltered.

For details about data transfer request overflow, see [Section 29.3.2.2.2, Interrupt and Data Transfer Request Overflow](#).

29.2.9.5 ETPUCIER - eTPU Channel Interrupt Enable Register

Host interrupt enable (see [Section 29.3.2.2, Interrupts and Data Transfer Requests](#)) from all channels are grouped in ETPUCIER. Their bits are mirrored from the Channel Configuration registers (see [Section 29.2.10.2, ETPUCxSCR - eTPU Channel x Status Control Register](#)).

eTPU A: Base + 0x240 / eTPU B: Base + 0x244

| | | | | | | | | | | | | | | | | |
|--------|-----|-----|-----|-----|-----|-----|-----|-----|-----|-----|-----|-----|-----|-----|-----|-----|
| | 0 | 1 | 2 | 3 | 4 | 5 | 6 | 7 | 8 | 9 | 10 | 11 | 12 | 13 | 14 | 15 |
| R | CIE | CIE | CIE | CIE | CIE | CIE | CIE | CIE | CIE | CIE | CIE | CIE | CIE | CIE | CIE | CIE |
| W | 31 | 30 | 29 | 28 | 27 | 26 | 25 | 24 | 23 | 22 | 21 | 20 | 19 | 18 | 17 | 16 |
| RESET: | 0 | 0 | 0 | 0 | 0 | 0 | 0 | 0 | 0 | 0 | 0 | 0 | 0 | 0 | 0 | 0 |

| | | | | | | | | | | | | | | | | |
|--------|-----|-----|-----|-----|-----|-----|-----|-----|-----|-----|-----|-----|-----|-----|-----|-----|
| | 16 | 17 | 18 | 19 | 20 | 21 | 22 | 23 | 24 | 25 | 26 | 27 | 28 | 29 | 30 | 31 |
| R | CIE | CIE | CIE | CIE | CIE | CIE | CIE | CIE | CIE | CIE | CIE | CIE | CIE | CIE | CIE | CIE |
| W | 15 | 14 | 13 | 12 | 11 | 10 | 9 | 8 | 7 | 6 | 5 | 4 | 3 | 2 | 1 | 0 |
| RESET: | 0 | 0 | 0 | 0 | 0 | 0 | 0 | 0 | 0 | 0 | 0 | 0 | 0 | 0 | 0 | 0 |

= Unimplemented or Reserved

Figure 29-19. ETPUCIER Register

CIEx — Channel x Interrupt Enable

1 = interrupt enabled for channel x

0 = interrupt disabled for channel x.

For details about interrupts see the *eTPU Reference Manual* for details.

29.2.9.6 ETPUCDTRER - eTPU Channel Data Transfer Request Enable Register

Data Transfer request enable (see [Section 29.3.2.2, Interrupts and Data Transfer Requests](#)) from all channels are grouped in ETPUCDTRER. These bits are mirrored from the Channel Configuration registers (see [Section 29.2.10.2, ETPUCxSCR - eTPU Channel x Status Control Register](#)).

eTPU A: Base + 0x250 / eTPU B: Base + 0x254

| | | | | | | | | | | | | | | | | |
|--------|------|------|------|------|------|------|------|------|------|------|------|------|------|------|------|------|
| | 0 | 1 | 2 | 3 | 4 | 5 | 6 | 7 | 8 | 9 | 10 | 11 | 12 | 13 | 14 | 15 |
| R | DTRE | DTRE | DTRE | DTRE | DTRE | DTRE | DTRE | DTRE | DTRE | DTRE | DTRE | DTRE | DTRE | DTRE | DTRE | DTRE |
| W | 31 | 30 | 29 | 28 | 27 | 26 | 25 | 24 | 23 | 22 | 21 | 20 | 19 | 18 | 17 | 16 |
| RESET: | 0 | 0 | 0 | 0 | 0 | 0 | 0 | 0 | 0 | 0 | 0 | 0 | 0 | 0 | 0 | 0 |

| | | | | | | | | | | | | | | | | |
|--------|------|------|------|------|------|------|------|------|------|------|------|------|------|------|------|------|
| | 16 | 17 | 18 | 19 | 20 | 21 | 22 | 23 | 24 | 25 | 26 | 27 | 28 | 29 | 30 | 31 |
| R | DTRE | DTRE | DTRE | DTRE | DTRE | DTRE | DTRE | DTRE | DTRE | DTRE | DTRE | DTRE | DTRE | DTRE | DTRE | DTRE |
| W | 15 | 14 | 13 | 12 | 11 | 10 | 9 | 8 | 7 | 6 | 5 | 4 | 3 | 2 | 1 | 0 |
| RESET: | 0 | 0 | 0 | 0 | 0 | 0 | 0 | 0 | 0 | 0 | 0 | 0 | 0 | 0 | 0 | 0 |

= Unimplemented or Reserved

Figure 29-20. ETPUCDTRER Register

DTREx — Channel x Data Transfer Request Enable

1 = Data Transfer request enabled for channel x.

0 = Data Transfer request disabled for channel x.

For details about interrupts see the *eTPU Reference Manual* for details.

29.2.9.7 ETPUCPSSR - eTPU Channel Pending Service Status Register

ETPUCPSSR is a read-only register that holds the status of the pending Channel Service Requests (see the *eTPU Reference Manual* for details).

eTPU A: Base + 0x280 / eTPU B: Base + 0x284

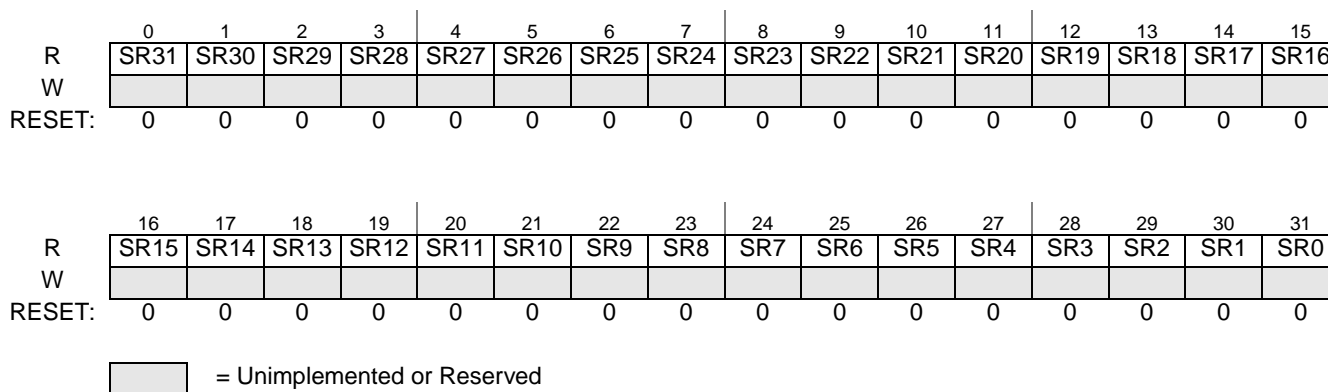

Figure 29-21. ETPUCPSSR Register

SRx - Pending Service Request x

Indicates a pending Service Request for channel x.

1 = pending Service Request for channel x

0 = no Service Request pending for channel x

Pending SR status is a logic OR of all service requests pending: if only HSR is active, SRx clears only at the end of the thread. SRx clear due to the other request sources is microcode dependent.

NOTE

The pending service status bit for a channel is 1 when a Service Request is pending, even if the Channel is disabled (CPRx = 0).

NOTE

There can be a delay of one clock between writing HSR > 0 in register ETPUCxHSRR of a channel and its respective bit being asserted in ETPUCPSSR.

29.2.9.8 ETPUCSSR - eTPU Channel Service Status Register

ETPUCSSR holds the current channel service status on whether it is being serviced or not (see the *eTPU Reference Manual* for details). Only one bit may be asserted in this register at a given time. When no channel is being serviced the register read value is 0x00000000. ETPUCSSR is a read-only register. The register can be read during normal eTPU operation for monitoring the scheduler activity.

NOTE

Channel Service Status does not always reflect decoding of the CHAN register, since the later can be changed by the service thread microcode.

eTPU A: Base + 0x290 / eTPU B: Base + 0x294

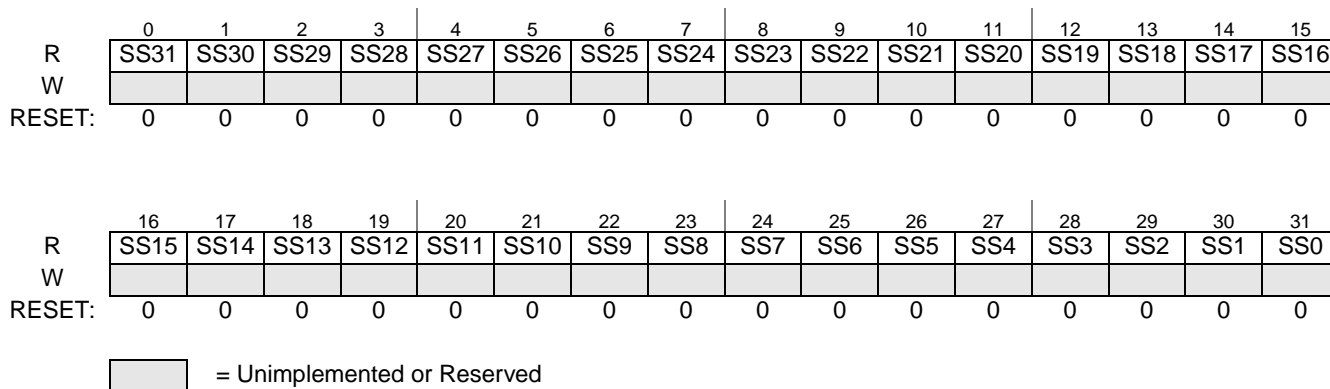

Figure 29-22. ETPUCSSR Register

SSx - Service Status x

Indicates that channel x is currently being serviced. It is updated at the 1st microcycle of a Time Slot Transition (see the *eTPU Reference Manual* for details), or when the microengine ends the thread.

- 1 = channel x is currently being serviced
- 0 = channel x is not currently being serviced

29.2.10 Channel Configuration and Control Registers

Each channel has a group of 3 registers used to control, configure and check status of that channel as shown in [Table 29-13](#). This organization eases individual channel management.

NOTE

A bus error is issued on read or write accesses to these registers when ETPUECR bit MDIS=1. Writes are ineffective on bus error.

Table 29-13. Channel Registers Structure

| Channel Offset | Register Name |
|----------------|---|
| 0x00 | ETPUCxCR - eTPU Channel Configuration Register |
| 0x04 | ETPUCxSCR - eTPU Channel Status/Control Register |
| 0x08 | ETPUCxHSRR - eTPU Channel Host Service Request Register |
| 0x0C | Reserved |

One contiguous area is used to map all channel registers of each eTPU engine as shown in [Table 29-14](#).

Table 29-14. Channel Registers Map

| Offset | Registers Structure |
|--------|---------------------------------------|
| 0x400 | eTPU A Channel 0 Registers Structure |
| 0x410 | eTPU A Channel 1 Registers Structure |
| 0x420 | eTPU A Channel 2 Registers Structure |
| 0x430 | . |
| | . |
| 0x5E0 | eTPU A Channel 30 Registers Structure |
| 0x5F0 | eTPU A Channel 31 Registers Structure |
| 0x600 | Reserved |
| 0x800 | eTPU B Channel 0 Registers Structure |
| 0x810 | eTPU B Channel 1 Registers Structure |
| 0x820 | . |
| | . |
| 0x9E0 | eTPU B Channel 30 Registers Structure |
| 0x9F0 | eTPU B Channel 31 Registers Structure |
| 0xA00 | Reserved |

There are 64 structures defined, one for each available channel in the eTPU System (32 for each Engine). The base address for the structure presented can be calculated by using the following equation:

$$\text{Channel_Register_Base} = \text{ETPU_Engine_Channel_Base} + (\text{channel_number} * 0x10)$$

where:

$$\text{ETPU_Engine_Channel_Base} = \text{ETPU_Base} + 0x400 \text{ for Engine 1}$$

$$\text{ETPU_Engine_Channel_Base} = \text{ETPU_Base} + 0x800 \text{ for Engine 2}$$

29.2.10.1 ETPUCxCR - eTPU Channel x Configuration Register

ETPUCxCR gathers configurations set individually per channel.

Channel_Register_Base + 0x0

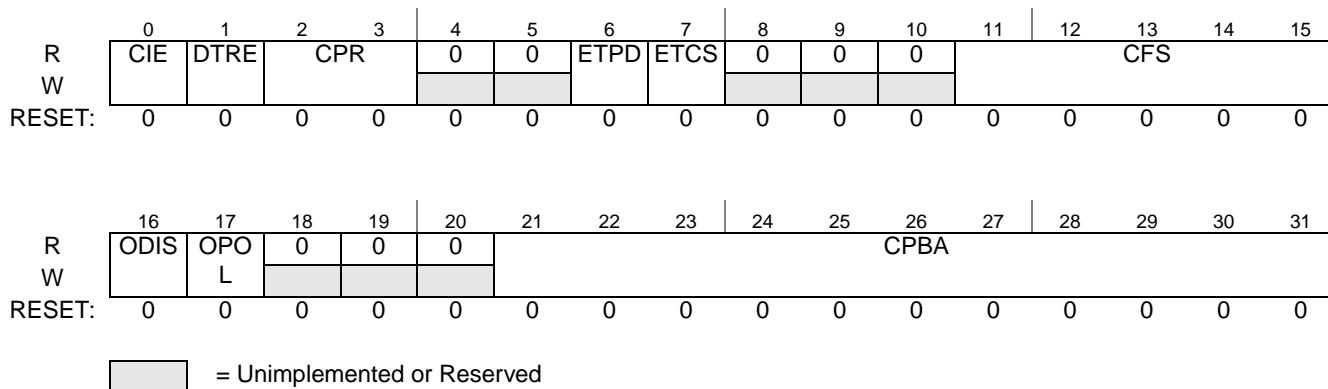

Figure 29-23. ETPUCxCR Register

NOTE

The fields ETCS, CFS and CPBA must only be changed while the channel is disabled (field CPR=00).

CIE — Channel Interrupt Enable

(this bit is mirrored from ETPUCIER - see [Section 29.2.9.5, ETPUCIER - eTPU Channel Interrupt Enable Register](#))

- 1 = Enable interrupt for this channel.
- 0 = Disable interrupt for this channel.

See the *eTPU Reference Manual* for details.

DTRE — Channel Data Transfer Request Enable

(this bit is mirrored from ETPUCDTRER - see [Section 29.2.9.6, ETPUCDTRER - eTPU Channel Data Transfer Request Enable Register](#))

- 1 = Enable data transfer request for this channel.
- 0 = Disable data transfer request for this channel.

See the *eTPU Reference Manual* for details.

CPR[0:1] — Channel Priority

This field defines the priority level for the channel, used by the Hardware Scheduler (See [Section 29.3.3, Scheduler](#)).

Table 29-15. Priority level Bits

| CPR | Priority |
|-----|----------|
| 00 | Disabled |
| 01 | Low |
| 10 | Middle |

Table 29-15. Priority level Bits (continued)

| CPR | Priority |
|-----|----------|
| 11 | High |

ETPD — Entry Table Pin Direction

This bit selects which channel signal, input or output, is used in the Entry Point selection. The ETPD value has to be compatible with the function chosen for the channel, selected in the field CFS. For details about Entry Table and condition encoding schemes, refer to the *eTPU Reference Manual*.

- 1 = use PSTO for Entry Point selection.
- 0 = use PSTI for Entry Point selection.

ETCS — Entry Table Condition Select

This bit determines the channel condition encoding scheme that selects, according to channel conditions, the Entry Point to be taken in an Entry Table. ETCS value has to be compatible with the function chosen for the channel, selected in field CFS. Two condition encoding schemes are available. For details about Entry Table and condition encoding schemes, refer to the *eTPU Reference Manual*.

- 1 = select Alternate Entry Table Condition encoding scheme.
- 0 = select Standard Entry Table Condition encoding scheme.

CFS[0:4] — Channel Function Select

This field defines the function to be performed by the channel (see the *eTPU Reference Manual* for details). The Function assigned to the channel has to be compatible with the channel condition encoding scheme, selected by field ETCS.

ODIS — Output Disable

This bit enables the channel to have its output forced to the value opposite to OPOL when the output disable input signal corresponding to the channel group that it belongs is active. See [Section 29.2.2.4, eTPU Channel Output Disable Signals](#), and the *eTPU Reference Manual* for details.

- 1 = turns on the output disable feature for the channel
- 0 = turns off the output disable feature for the channel.

OPOL - Output Polarity

Determines the output signal polarity. The activation of the output disable signal forces, when enabled by the ODIS bit, the channel output signal to the opposite of this polarity (see the *eTPU Reference Manual* for details).

- 1 = output active high (output disable drives output to low)
- 0 = output active low (output disable drives output to high)

CPBA[0:10] — Channel x Parameter Base Address

The value of this field times 8 specifies the SDM parameter base host (byte) address for channel x (2-parameter granularity; see [Section 29.3.2.4, SDM Organization](#)). As seen by the Host, the channel parameter base (byte) address is:

- without parameter sign extension: $ETPU_Base + 0x8000 + CPBA * 8$
- with parameter sign extension: $ETPU_Base + 0xC000 + CPBA * 8$

29.2.10.2 ETPUCxSCR - eTPU Channel x Status Control Register

ETPUCxSCR gathers the interrupt status bits of the channel, and also the Function Mode definition (read-write). Bits CIS, CIOS and DTRS for each channel can be also accessed from ETPUCISR, ETPUCIOSR and ETPUCDTRSR registers respectively (see [Section 29.2.9, Global Channel Registers](#)). Host must write 1 to clear a status bit.

Channel_Register_Base + 0x4

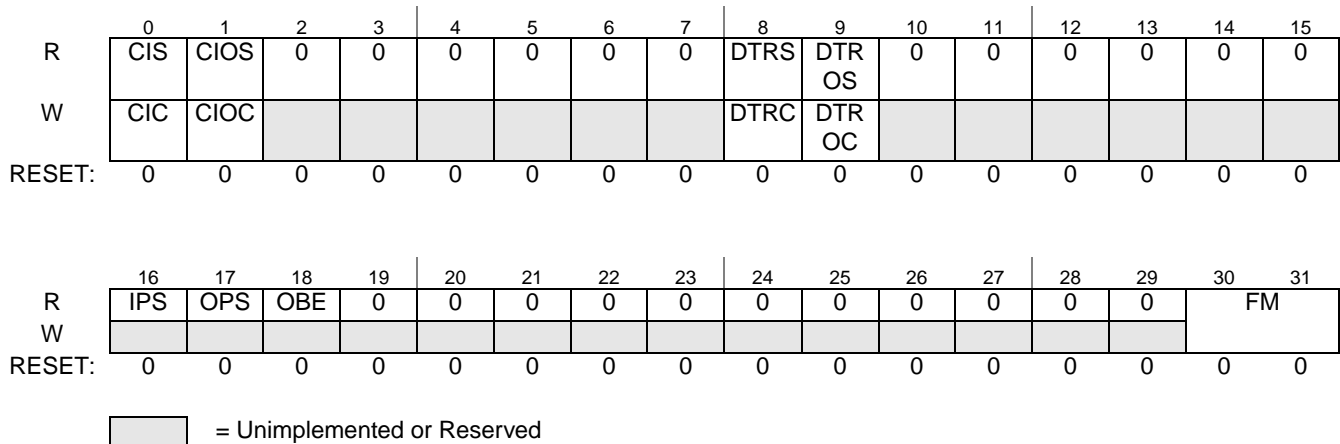

Figure 29-24. ETPUCxSCR Register

CIS — Channel Interrupt Status

- 1 = channel has a pending interrupt to the Host CPU.
- 0 = channel has no pending interrupt to the Host CPU.

CIC — Channel Interrupt Clear

- 1 = clear interrupt status bit.
- 0 = keep interrupt status bit unaltered.

These bits are mirrored in ETPUCISR - see [Section 29.2.9.1, ETPUCISR - eTPU Channel Interrupt Status Register](#)). See also the *eTPU Reference Manual* for details.

CIOS — Channel Interrupt Overflow Status

- 1 = interrupt overflow asserted for this channel
- 0 = interrupt overflow negated for this channel

CIOC — Channel Interrupt Overflow Clear

- 1 = clear status bit.
- 0 = keep status bit unaltered.

These bits are mirrored in ETPUCIOSR - see [Section 29.2.9.3, ETPUCIOSR - eTPU Channel Interrupt Overflow Status Register](#)). See also [Section 29.3.2.2.2, Interrupt and Data Transfer Request Overflow](#).

DTRS — Data Transfer Request Status

- 1 = Channel has a pending data transfer request.
- 0 = Channel has no pending data transfer request.

DTRC — Data Transfer Request Clear

Enhanced Time Processing Unit (eTPU2)

1 = clear status bit.

0 = keep status bit unaltered

These bits are mirrored in ETPUCISR - see [Section 29.2.9.2, ETPUCDTRSR - eTPU Channel Data Transfer Request Status Register](#)). See also the *eTPU Reference Manual* for details.

DTROS — Data Transfer Request Overflow Status

1 = data transfer request overflow asserted for this channel

0 = data transfer request overflow negated for this channel

DTROC — Data Transfer Request Overflow Clear

1 = clear status bit.

0 = keep status bit unaltered.

These bits are mirrored in ETPUCDTROSR - see [Section 29.2.9.4, ETPUCDTROSR - eTPU Channel Data Transfer Request Overflow Status Register](#)). See also [Section 29.3.2.2.2, Interrupt and Data Transfer Request Overflow](#).

IPS — Channel Input Pin State

This bit shows the current value of the filtered channel input signal state

OPS — Channel Output Pin State

This bit shows the current value driven in the channel output signal, including the effect of the external output disable feature (see [Section 29.2.2.4, eTPU Channel Output Disable Signals](#)). If the channel input and output signals are connected to the same pad, OPS reflects the value driven to the pad (if OBE=1). This is not necessarily the actual pad value, which drives the value in the bit IPS.

OBE — Output Buffer Enable

This bit shows the state of the channel output buffer enable signal, controlled by microcode.

FM[0:1] — Channel Function Mode¹

Each function uses this field for specific configuration. These bits can be tested by microengine code (see the *eTPU Reference Manual* for details).

1. These bits are equivalent to the TPU/TPU2/TPU3 Host Sequence (HSQ) bits.

29.2.10.3 ETPUCxHSRR - eTPU Channel x Host Service Request Register

ETPUCxHSRR is used by the Host to issue service requests to the channel.

Channel_Register_Base + 0x8

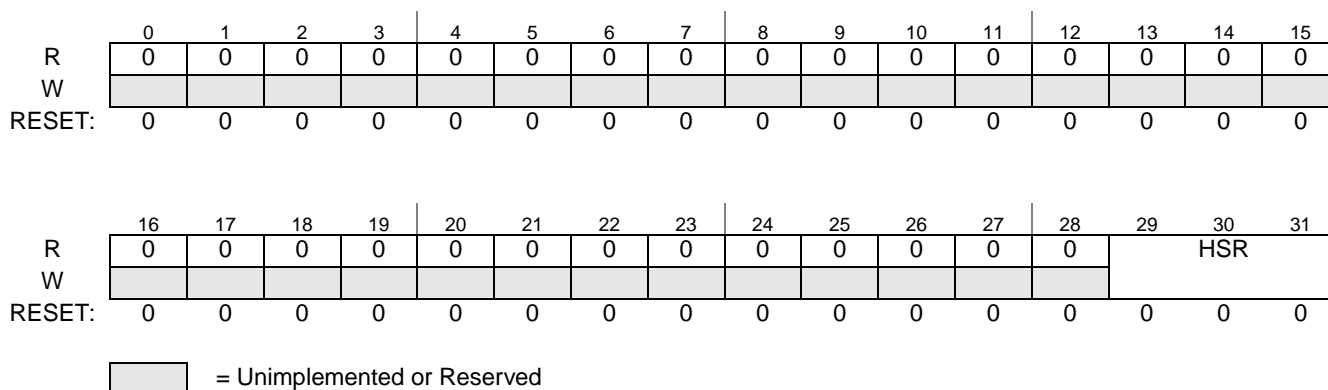

Figure 29-25. ETPUCxHSRR Register

HSR[0:2] — Host Service Request

This field is used by the Host CPU to request service to the channel (see [Section 29.3.2.5, Host Service Requests](#))

HSR = 000: no Host Service Request pending

HSR > 000: function-dependent Host Service Request pending.

HSR value turns to 000 automatically at the end of microengine service for that channel, but only if the thread started due to an HSR. Host should write HSR>0 only when HSR=0. Writing HSR=000 withdraws a pending request if scheduler did not begin to resolve the Entry Point yet, but it does not abort the service thread from that point on. For more details, see the *eTPU Reference Manual* and [Section 29.3.2.5, Host Service Requests](#).

29.3 Functional Description

29.3.1 Watchdog

Each engine has a watchdog mechanism to prevent a thread or a sequence of threads from running too long, impacting the latency of the other channel services. The watchdog is configured through the register ETPUWDTR (see [Section 29.2.7.1, ETPUWDTR - eTPU Watchdog Timer Register](#)). When the watchdog is enabled, an internal counter increments on each microcycle when a thread is executing. If the count is greater than the value specified in the ETPUWDTR field WDCNT and a thread is still executing, the watchdog:

1. Forces an END of the thread
2. Issues a Global Exception and sets the ETPUMCR bit WDTO (see [Section 29.2.5.1, ETPUMCR - eTPU Module Configuration Register](#)).

The watchdog can be configured in one of the following modes, defining how the internal watchdog count is reset:

- **Thread Length Mode:** the watchdog count is reset at the end of each thread.
- **Busy Length Mode:** the watchdog count is reset when the microengine goes idle. A sequence of threads, one right after another, keeps the count running. The counter is also reinitialized when a thread is forced to end, so that a new count begins if another TST initiates at the following microcycle.

The following applies to the watchdog mechanism:

- Microcycles during TST and SDM access wait-states (on TST or instruction execution) are counted.
- If the watchdog count equals WDCNT in the last microinstruction (with SDM wait-states or not) of a thread servicing a channel.
- If the watchdog count expires (gets greater than WDCNT) during the TST, the thread is forced end on its first instruction.
- The watchdog count does not wrap, so that a thread (in thread length mode) or a thread sequence (in busy length mode) that lasts for more than the maximum value of WDCNT does get a forced end.

NOTE

Watchdog must not be enabled when the microengine enters halt mode. The counter does not run when the engine is stopped, and resets when the watchdog is disabled.

29.3.2 Host Interface

29.3.2.1 System Configuration

System Configuration Registers are described in [Section 29.2.5, System Configuration Registers](#). Detailed explanation on the configured functionalities is found throughout [Section 29.3, Functional Description](#).

29.3.2.2 Interrupts and Data Transfer Requests

29.3.2.2.1 Interrupt Types and Sources

Each one of the eTPU channels can be a source of two requests: **Channel Interrupt** request and **Data Transfer Request**. Channel Interrupts are targeted to a Host CPU. Data Transfer Requests may be targeted to a data transfer module (e.g., a DMA controller). Interrupt and Data Transfer registers are used by the Host to enable interrupts and data transfer requests, indicate their status and service them. Interrupt and Data Transfer requests have the same sets of registers and external signals, and are handled in the same way. They differ only by the fact that Data Transfer Requests are also cleared by the assertion of respective DMA completion acknowledge line. Data Transfer Requests can be used as another source for Host interrupts at MCU integration if not used with a DMA.

NOTE

Interrupt and Data Transfer requests can be cleared even when Engines are in Module Disable Mode, through the Global Channel Registers, and also DMA completion for Data Transfer requests.

Channel Interrupts and Data Transfer Requests can only be issued by eTPU microcode, through one of the Channel Control instruction fields (see the *eTPU Reference Manual* for details).

Both Channel Interrupt and Data Transfer requests can be individually enabled for each channel.

eTPU Interrupt and Data Transfer Registers are mirrored in two organizations: grouped by Channel and grouped by type (interrupt status, interrupt enable, data transfer status, data transfer enable). This allows either “channel-oriented” or “bundled channel” Host interrupt service schemes, or a combination of them. For a detailed description, refer to [Section 29.2.8, Channel Registers Layout](#), and [Section 29.2.9, Global Channel Registers](#).

eTPU can also assert a **Global Exception** interrupt indicating a global illegal state. There are four possible sources for a Global Exception:

- Watchdog Timeout, if enabled by the ETPUWDTR register. See [Section 29.3.1, Watchdog](#).
- Execution of an illegal instruction by the microengine (see the *eTPU Reference Manual* for details). This Global Exception source is flagged by the bits ILF1 and ILF2 in register ETPUMCR.
- An SCM signature mismatch detected by the Multiple Input Signature Calculator - MISC. See [Section 29.3.6.1, SCM Test - Multiple Input Signature Calculator](#). This source is flagged by the bit SCMMISF in register ETPUMCR.
- Microcode request, through microinstruction field CIRC (see the *eTPU Reference Manual* for details). This Global Exception source is flagged by bits MGE1(Engine A) and MGE2(Engine B) in register ETPUMCR. The cause of this illegal state is application-dependent. The microcode may write an error code into the SDM to indicate the cause of the exception, for instance.

Global Exceptions cannot be directly disabled within eTPU, except by disabling its sources (Memory Error, MISC and microcode), and it is cleared by writing 1 to the GEC bit in ETPUMCR. Clearing Global Exception clears all Global Exception source status bits (ILF1, ILF2, SCMMISF, MGE1, MGE2, SCMERR, SDMERR). If GEC is written 1 at the same time any of the sources issues a Global Exception, both the interrupt and the status bit of that source remains asserted. The assertion of Global Exception by one of the sources above does not prevent the others from asserting it too, so any number of them, in any combination, can be flagged.

NOTE

There can be a race between the clear of a Global Exception and occurrence of a new set condition, such that the set happens just before the clear and cannot be sensed by the Host. Therefore, Global Exception cannot be used as a normal interrupt source: it should only be used for emergency procedures.

29.3.2.2.2 Interrupt and Data Transfer Request Overflow

If a Channel Interrupt was issued, its status bit is still set, and microcode issues another Channel Interrupt, the Interrupt Overflow status bit is set for that channel. Interrupt Overflow status can be checked by the Host in Channel Status register ETPUCxSCR bit CIOS ([Section 29.2.10.2, ETPUCxSCR - eTPU Channel x Status Control Register](#)), mirrored in register ETPUCIOSR ([Section 29.2.9.3, ETPUCIOSR - eTPU Channel Interrupt Overflow Status Register](#)). Interrupt Overflow status is not cleared automatically when Interrupt Status is cleared. The same mechanism and respective registers (ETPUCDTROSR) are available for Data Transfer Requests.

If interrupt is set and cleared at the same time, set prevails and overflow is not altered (keeps the same state as it was before, asserted or not).

Global Exception has no overflow status.

29.3.2.3 Parameter Access

29.3.2.3.1 Parameter Access Widths

From the Host side the SDM address space is mapped in bytes, and each 32-bit parameter occupies 4 contiguous, aligned bytes. The Host can read/write the SDM by 8-, 16-, or 32-bit accesses in aligned addresses.

In 32-bit access, Host can access all 32 bits or only the lower 24 bits with an automatic sign extension (see [Section 29.3.2.3.4, Parameter Sign Extension Area](#)).

29.3.2.3.2 Parameter Addresses and Endianness

To access parameter number *xxx*, eTPU Microengine(s) would select address *xxx*. The Host would add ($xxx*4$) to the SDM base address to access the same parameter. For example, parameter 0x101 is seen by the Host in (*SDM base address + 0x404*). An example of SDM memory map is shown in [Figure 29-26](#). The Host can access the SDM with a 32-bit-wide bus cycle to a four-byte aligned address, 16-bit-wide bus cycle to a two-byte aligned address, or 8-bit wide bus cycle to any byte address.

The address of the 24-bit parameters and the most significant byte depends on the endianness of the MCU.

29.3.2.3.3 Parameter Concurrency

Host accesses to parameters may occur in parallel with eTPU Microengine accesses. Readings taken from a group of parameters while they are being simultaneously updated may lack coherency. eTPU provides mechanisms to ensure parameter coherency in accesses from both Host side and Microengine side, including the use of a coherent dual-parameter transfer mechanism, described in detail on [Section 29.3.4, Parameter Sharing and Coherency](#).

29.3.2.3.4 Parameter Sign Extension Area

The SDM address space to the Host is mirrored in a Parameter Sign Extension - PSE - area (see [Section 29.2.4, Memory Map](#)). Accesses from the Host to the PSE area differ from accesses to the standard SDM address space as follows:

- **Writes:** the most significant byte of the parameters is not written, and the SDM retains the old byte value, regardless of the Host access size.
- **Reads:** the most significant bit of the 24-bit parameter (that is, the msbit of the second most significant 32-bit parameter byte) is repeated in the 8 most significant bits of the read value on all 32-bit reads and most significant 16- and 8-bit reads.

The same parameters written in the standard SDM address space are read from the PSE area with the same offsets, and vice-versa.

This feature relieves the Host from extending the signal of 24-bit eTPU parameters before calculations, and from read-modify-write accesses to modify 24-bit parameters at the SDM.

29.3.2.4 SDM Organization

The SDM internal partition for channel allocation is dynamic and programmed in the Channel Registers (see [Section 29.2.10.2, ETPUCxSCR - eTPU Channel x Status Control Register](#)).

The Host application is responsible for allocating a different parameter base address to each channel during the initial eTPU configuration, and to allocate enough parameters for the selected Function, with no unintentional overlapping between parameters of different functions.

Besides channel parameters, global areas may have to be allocated for parameters that are shared by more than one channel, in one or both Engines. Also, temporary parameter areas should be reserved to be used by the coherent parameter transfer mechanisms described in [Section 29.3.4, Parameter Sharing and Coherency](#), if necessary.

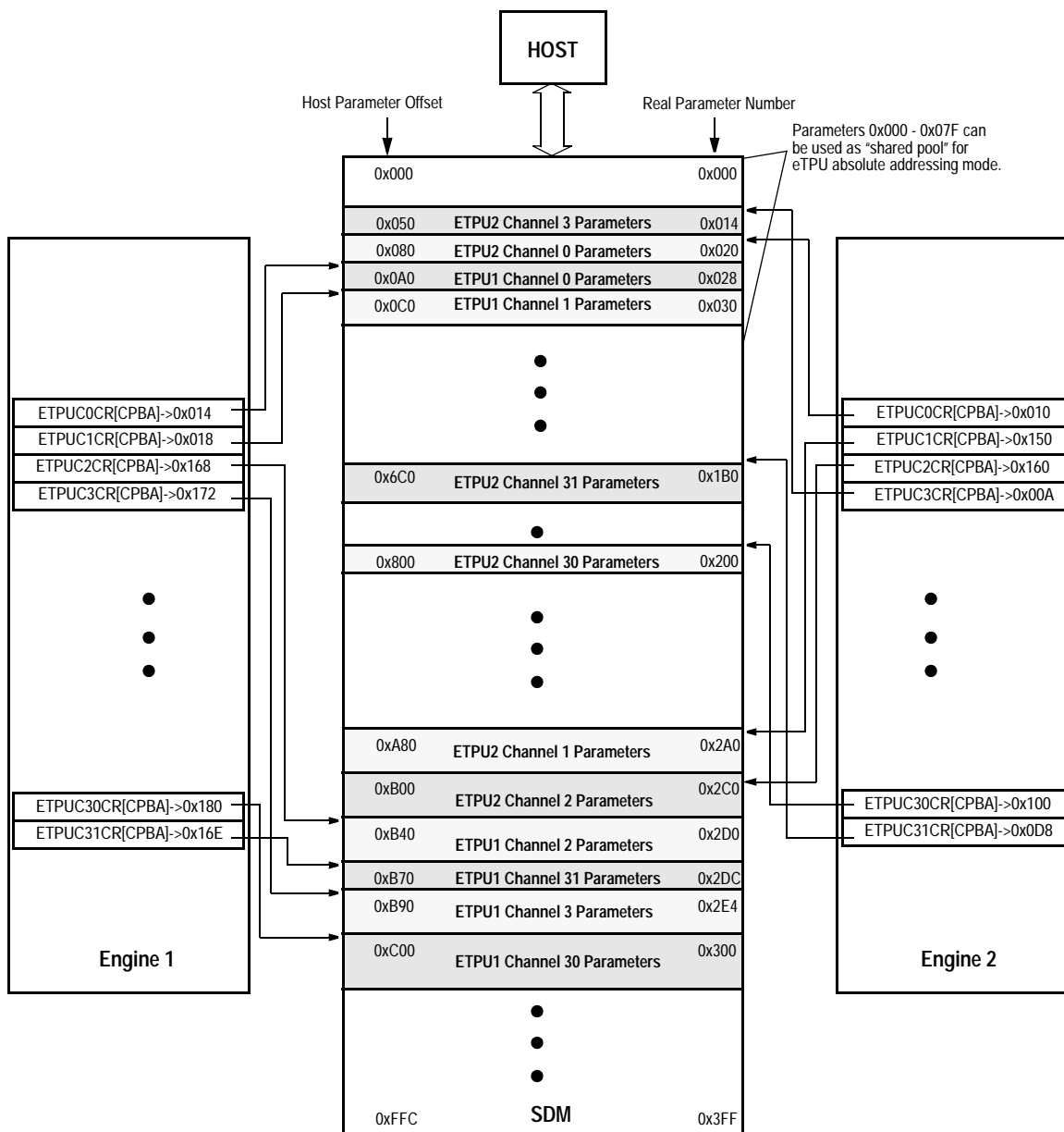

Figure 29-26. SDM Organization Example (4 Kbytes)

Single-engine eTPU or dual eTPU system may require less parameters than the maximum number provided by the SDM. Since the SDM partition is fully dynamic, there is no limitation of fixed channel addresses, and the reduced array can be fully utilized.

29.3.2.5 Host Service Requests

Host CPU can request immediate service from a channel by writing a non-zero value to the Host Service Request register field - HSR (see [Section 29.2.10.3, ETPUCxHSRR - eTPU Channel x Host Service Request Register](#)). There is one HSR field for each channel, so that writing to it generates a Service Request to the respective channel only. A zero value in HSR means no Host Service Request is pending for the channel.

HSR value turns to 000 automatically at the end of microengine service for that channel, but only if the thread started due to an HSR.

The meaning of a non-zero HSR value depends on the Function assigned for the channel. These bits are part of the conditions which select the Function entry point, and cannot be tested by microcode. For more details, refer to the *eTPU Reference Manual*.

If Host writes HSR=000 when a thread for the same channel is already running, the thread runs until the end and is not aborted. If Host writes HSR>000 when an HSR thread for the same channel is already running, HSR value resets at the end of the thread, and no new HSR will be pending. If HSR is written before its value is resolved by the scheduler during TST, the entry point will obey the new HSR value, and if this new value is 000, no service thread is executed for the HSR.

The scheduling of HSRs is completely asynchronous with Host accesses, and there is no race-free manner to change an HSR value before service thread execution, so generally the safe way is: write HSR>0 only when HSR=0. Error recovery or emergency host procedures may require one to safely abort service and reset channel state when an HSR is already pending or executing. In these cases, the procedure below should be followed:

1. Disable the channel, writing CPR=00 in register ETPUCxCR. That will prevent any pending HSR to be serviced.
2. Check if the channel is currently being serviced, reading its service status bit in register ETPUCSSR. If it is, wait for the time necessary to finish the service pending, or check again until HSR == 0, or channel service bit in ETPUCSSR is cleared.
3. Write HSR with the error recover value. This value should, possibly combined with other host-defined flags in SDM or FM bits, initiate a channel reset or error recovery procedure.
4. Re-enable the channel, writing CPR value > 0 in register ETPUCxCR.

29.3.2.6 SCM access

Only Host can access SCM as data. Depending on the specific device, SCM may be implemented as a RAM or ROM. This determines Host accesses to the SCM as shown below.

29.3.2.6.1 SCM RAM Implementations

When SCM is implemented as RAM, the Host may read or write to SCM by setting ETPUMCR bit VIS=1. If VIS=0 and Host tries to access SCM space, a bus error is issued, writes are ineffective and read data is meaningless. Both Engines must be stopped or halted to set VIS=1.

NOTE

It is necessary to turn VIS bit on to set software breakpoints (see the *eTPU Reference Manual* for details).

29.3.2.6.2 SCM Low Power

SCM turns off its internal clocks when both Engines are stopped (ETPUECR bit STF asserted), VIS=0 at ETPUMCR, and MISC is not enabled (SCMMISEN=0). The SCM clocks are automatically turned on if either one of the STF bits is negated or VIS turns to 1, or SCMMISEN turns to 1.

SCM clocks are not turned off if any of the Engines is not stopped, even if they are both halted.

The conditions for SCM Clocks and MISC activation are summarized in [Table 29-16](#).

Table 29-16. SCM Clocks and MISC activation

| ETPUECR_1 STF | ETPUECR_2 STF | ETPUMCR VIS | ETPUMCR SCMMISEN | SCM Clocks | MISC |
|------------------|------------------|----------------|---------------------|---------------|------------------|
| 0 | x | 0 ¹ | 1 | On | On |
| 0 | x | 0 ¹ | 0 | On | off |
| x | 0 | 0 ¹ | 1 | On | On |
| x | 0 | 0 ¹ | 0 | On | off |
| 1 | 1 | 0 | 0 | off | off |
| 1 | 1 | 0 | 1 | On | On |
| 1 ² | 1 ² | 1 | 0 | On | off |
| 1 ² | 1 ² | 1 | 1 | On | off ³ |
| 0 | 0 | x | 0 | On | off |
| 0 | 0 | x | 1 | On | On |

- ¹ VIS cannot be written 1 if ETPUECR_1 bit STF=0 or ETPUECR_2 bit STF=0, and both HLTF bits are 0.
- ² If VIS=1, neither MDIS can be written 0 nor the Engine leave Stop Mode, regardless of device stop reqes.
- ³ MISC resets and stays so when VIS=1, restarting automatically when VIS goes 0 if SCMMISEN=1.

29.3.2.6.3 SCM Off-range Data

When read accesses are made, either by the Host or by a microengine, to addresses above the limit corresponding to the SCMSIZE value in ETPUMCR, the value read comes from the register ETPUSCMOFFDATAR. The Host can program the register at initialization with an opcode value with operations that try to protect or recover the system from runaway code, for instance: terminate the thread, clear channel flags, disable match and transition service requests, issue an interrupt, jump to an error recovery procedure¹. Writes to unimplemented addresses do not return error and can write on unspecified mirror addresses, so they should be avoided.

1. Only part of these suggested operations can be parallelized in a single instruction. See the *eTPU Reference Manual* for details.

29.3.2.7 Bus Error Conditions

Follows a summary of the possible causes of bus errors on host accesses to the eTPU memory space:

- Read or write access to the SCM with ETPUMCR bit VIS=0.
- Read or write access to the channel registers with ETPUECR bits MDIS=1, or bit STF=1.
- Write access to the Time Base Registers with ETPUECR bits MDIS=1, or bit STF=1.
- Non-correctable errors in the SCM on reads of any size or writes less than 32-bits wide, when ETPUMECCR bit CEDD=0.
- Non-correctable errors in the SDM on reads, when ETPUMECCR bit DEDD=0.

29.3.3 Scheduler

Every Function is composed of one or more Threads. A Thread consists of a group of instructions that, once begins execution, cannot be interrupted by host or channel events. Each active channel intends to be serviced, being granted time for Thread execution. Since one microengine handles several channels operating concurrently, the Function threads must be executed serially.

The task of the Scheduler is to recognize and prioritize the channels needing service and to grant execution time to each channel. The time given to an individual Thread for execution or service is called a **Time Slot**. The duration of a time slot is determined by the number of instructions executed in the Thread plus SDM wait-states received, and varies in length.

At any time, an arbitrary number of channels can require service. To request service, channel logic, eTPU microcode or Host application notifies the Scheduler by issuing a Service Request.

29.3.3.1 Channel Enabling and Priority Assignment

Every channel is assigned one of three priority levels - high, middle, or low - by the Host CPU, through the Channel Configuration Register field CPR (see [Section 29.2.10.1, ETPUCxCR - eTPU Channel x Configuration Register](#)). These registers are also used to disable the channel, which is equivalent to assigning it a “null” priority. In this case, the Scheduler does not grant any of its Service Requests.

It is possible to change the channel priority level or disable it dynamically. If the Host disables a channel when it is currently being serviced, channel service thread will complete. This means that it is possible for the output level of a channel signal to change, or a Host interrupt occur, even after its priority register was written to “null”. For instance, if an output transition is scheduled, the transition will occur even after the channel is disabled.

Service requests previously pending or that occur while a channel is disabled remain asserted while the channel is disabled, and are serviced if the channel is enabled again, in due time determined by the priority scheme and concurrent requests from other channels. Channels are disabled after reset, and it is recommended to configure a Host Service Request for initialization of a channel before that channel is enabled to active priority (see [Section 29.4, Initialization/Application Information](#)).

29.3.3.2 Channel Priority Schemes

The Scheduler holds a Service Grant register with one bit for each channel. Once the Scheduler grants a time slot to channel, the Service Grant bit for that channel is asserted in the Service Grant register. When the Service Grant bit of a channel is set, the channel may request new service but is not serviced again before its Service Grant bit is cleared.

When all channels in a same priority level are serviced, their Service Grant bits are cleared at the end of the thread, one eTPU clock before the next serviced channel is calculated, according to the scheme below¹:

- Clear all grant bits of priority High if all channels of that priority that are requesting have their grant bits in 1.
- Clear all grant bits of priority Medium if all channels of that priority that are requesting have their grant bits in 1.
- Clear all grant bits of priority Low if all channels of that priority that are requesting have their grant bits in 1.
- Clear all grant bits of disabled channels.

This scheme assures that no channel is left with its grant bit forever asserted (preventing it from being serviced again), even if the channel priorities are reassigned during the execution.

Priority level is determined based on the maximum latency desired for each channel. A channel having a Function that requires the most frequent or more immediate service should be allocated a high priority level.

The eTPU employs a **primary** and a **secondary priority scheme**. These two schemes ensure frequent servicing of high-demand Functions and ensure a minimum time allocation to all channels requesting service, regardless of their priority level. The primary scheme prioritizes requesting channels that have different priority levels; the secondary scheme prioritizes requesting channels that have the same priority level.

Initially, a channel requests service and is granted a time slot by the Scheduler: Service Grant bit is asserted. If only high-level channels constantly receive service first because of their priority level, middle- and low-level channels would only be serviced by default, i.e., if no high-level channels request service. To ensure that each priority level receives an opportunity for servicing, every time slot has a fixed priority level that the Scheduler honors first. Divided into sets of seven, time slots are numbered from one to seven. [Figure 29-27](#) illustrates the numbered time slots in sets of seven (fields A and B) and identifies their assigned default priority level. The high level has more time slots than the middle and low levels. Out of every seven time slots available, four are assigned to honor high-level channels first, two are assigned to honor middle-level channels first, and one is assigned to honor low-level channels first. Only one request (in each Engine) is serviced per time slot. When no channel requests service and the microengine is idle the priority scheme is initialized to time slot one, to prevent priority inversion on the next request².

1. Grant bits are also cleared in the next clock, when the service channel is chosen, or when the microengine is idle, using the same scheme.
2. Priority inversion would occur in the following situation: no channel is requesting service, and the current time slot is primarily assigned to a low-priority channel. If the Scheduler was not reset to time slot one and two channels requested service at the same time, one with high priority and the other with low priority, the channel to be serviced would be the low-priority channel.

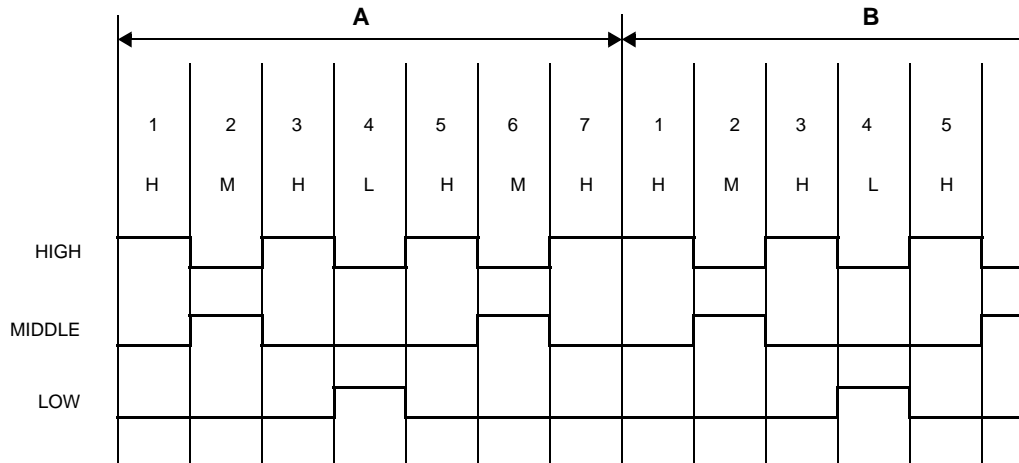

Figure 29-27. Time Slot Priority levels

29.3.3.2.1 Primary Scheme - Priority Among Channels on Different Levels

Although time slot priority assignment is fixed, the servicing priority is not. The primary scheme acknowledges the priority level assigned to a time slot, granting service first to a channel having the same priority. In [Figure 29-27](#), time slot one has a high-level assignment; therefore, a high-level channel requesting service is recognized first. However, if no high-level channel requests service, the Scheduler recognizes a requesting middle-level channel. If this level has no request, the Scheduler continues to the low-level. If no requests occur, the Scheduler truncates the seven state cycle and starts a new cycle at time slot one, waiting for the first request. Granting service to a different-level channel is called priority passing. The order of passing always gives the highest priority to the assigned level, and the second priority to the higher of the remaining requesting priority levels as shown in [Table 29-17](#).

Table 29-17. Priority Passing

| Assigned Priority Level | Next Priority Level | Next Priority Level |
|-------------------------|---------------------|---------------------|
| High | → Middle | → Low |
| Middle | → High | → Low |
| Low | → High | → Middle |

When priority is passed to another level, that level is serviced and the fixed-priority-level sequence is resumed with the next time slot.

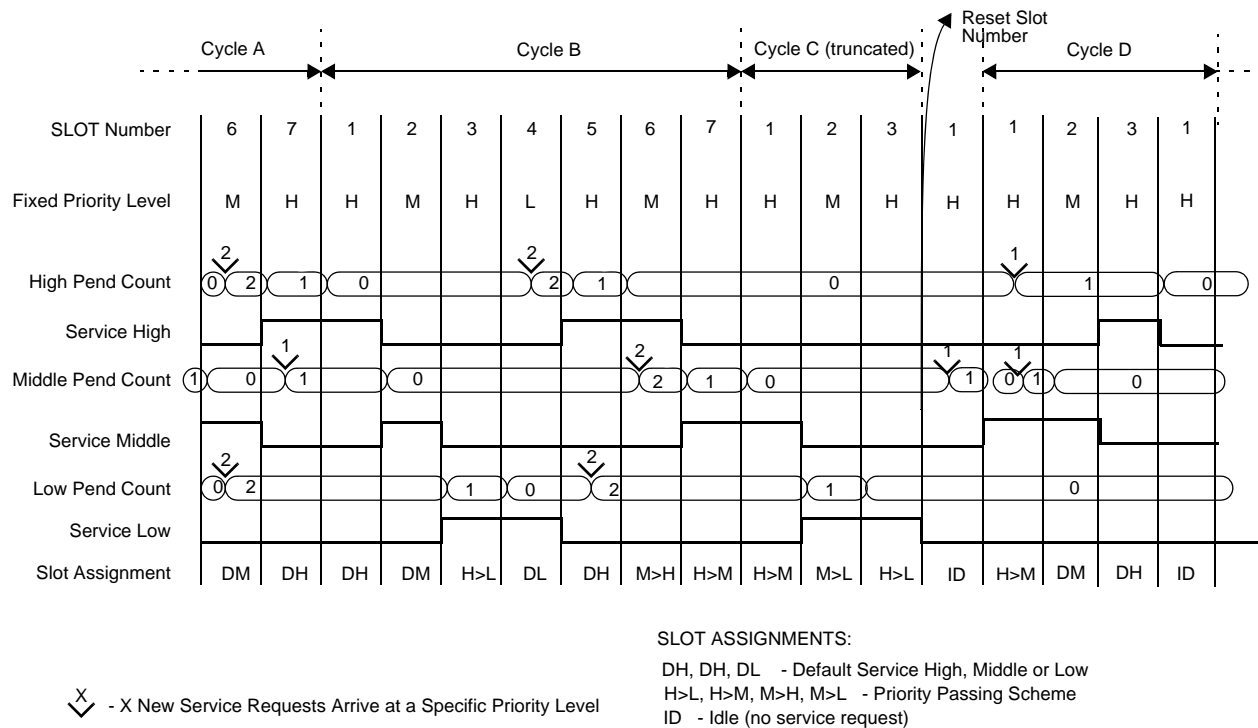

Figure 29-28. Priority Passing Example

Examples of priority passing are shown in Figure 29-28. Each cycle contains seven time slots (or less if no service request exist). In cycle B, no high-level or middle-level service requests are present before time slot three which is assigned by default to high-level priority. Thus, time slot three is passed to the low level. In cycle B there are also no middle-level service requests before time slot six, so it passes the priority to a requesting high-level channel. During time slot six no more high level requests are left, but two new middle-level requests arrive, and there are also three low level pending service requests. Thus, time slot seven of cycle B and time slot one of cycle C are passed to the middle-level which is the next priority level after high. Time slots two and three of cycle C are passed to the low level which contains the three remaining channel service requests. At time slot three of cycle C the last low level request is serviced, and the Scheduler passes to idle state. At this point the cycle C is truncated and the Scheduler passes to time slot one of cycle D.

29.3.3.2.2 Priority Passing Disabling

The priority passing scheme allows a case where a high priority channel loses to a lower priority one right after another lower priority has been serviced, exemplified in the Cycle D on [Figure 29-28](#). A middle priority channel wins time slot 1 due to priority passing from high to middle. While it is being serviced, two new service requests arrive, one high and one middle priority. The high priority request loses to the middle one on next time slot 2 by default priority assignment.

This priority inversion can be avoided by setting the ETPUECR register bit SPPDIS (see [Section 29.2.5.5, ETPUECR - eTPU Engine Configuration Register](#)), which disables the priority passing mechanism. When priority passing is disabled, at the end of the thread the slot number is incremented until a time slot that matches the priority of one of the requesting channel(s). The time slot advance takes no extra clocks. If no channel requests service, the time slot counter stays at time slot 1. The priority selection scheme with disabled priority passing is summarized in [Table 29-18](#).

Table 29-18. Priority Passing Disabling

| At the end of time slot | servicing priority | if any request of priority | service it on time slot | else if any request of priority | service it on time slot | else if any request of priority | service it on time slot |
|-------------------------|--------------------|----------------------------|-------------------------|---------------------------------|-------------------------|---------------------------------|-------------------------|
| 1 | High | Medium | 2 | High | 3 | Low | 4 |
| 2 | Medium | High | 3 | Low | 4 | Medium | 6 |
| 3 | High | Low | 4 | High | 5 | Medium | 6 |
| 4 | Low | High | 5 | Medium | 6 | Low | 4 |
| 5 | High | Medium | 6 | High | 7 | Low | 4 |
| 6 | Medium | High | 7 | Medium | 2 | Low | 4 |
| 7 | High | High | 1 | Medium | 2 | Low | 4 |

An example of the priority passing disabling scheme is illustrated in [Figure 29-29](#). The sequence of service requests is the same as in the example of [Figure 29-28](#), and although the time slot incrementing differs, the priorities granted are the same for cycle B. Cycle C has one of the low priority channels serviced before the second middle one. Cycle D, however, no longer has the priority inversion.

In cycle B, after the time slot 2 only a low priority request remains, so the time slot count advances directly to 4, which has a low priority assigned. Time slot keeps on 4 for the next service, as only a low priority request remains also, and only time slot 4 is assigned to low. Two high priority services contend for the next time slot 5 (assigned to High). The second high priority channel is serviced on the next time slot, jumped to 7 because there is no middle request, ending cycle B. Cycle C starts with time slot 2, as there are no high priority requests and two middle and two low ones. After the first middle service, time slot count skips 3 assigned to high (no high requests), and services a low priority channel on time slot 4. It follows the same scheme until there are no other requests and cycle C is truncated, resetting the time slot counter to 1.

Cycle D begins with a middle request, jumping to time slot 2. During this service two requests arrive, one high and one middle. Unlike what happened with priority passing, the next serviced is the high priority

channel, as the time slot increments to 3. The second middle priority channel request in cycle D is finally serviced next, on time slot 6.

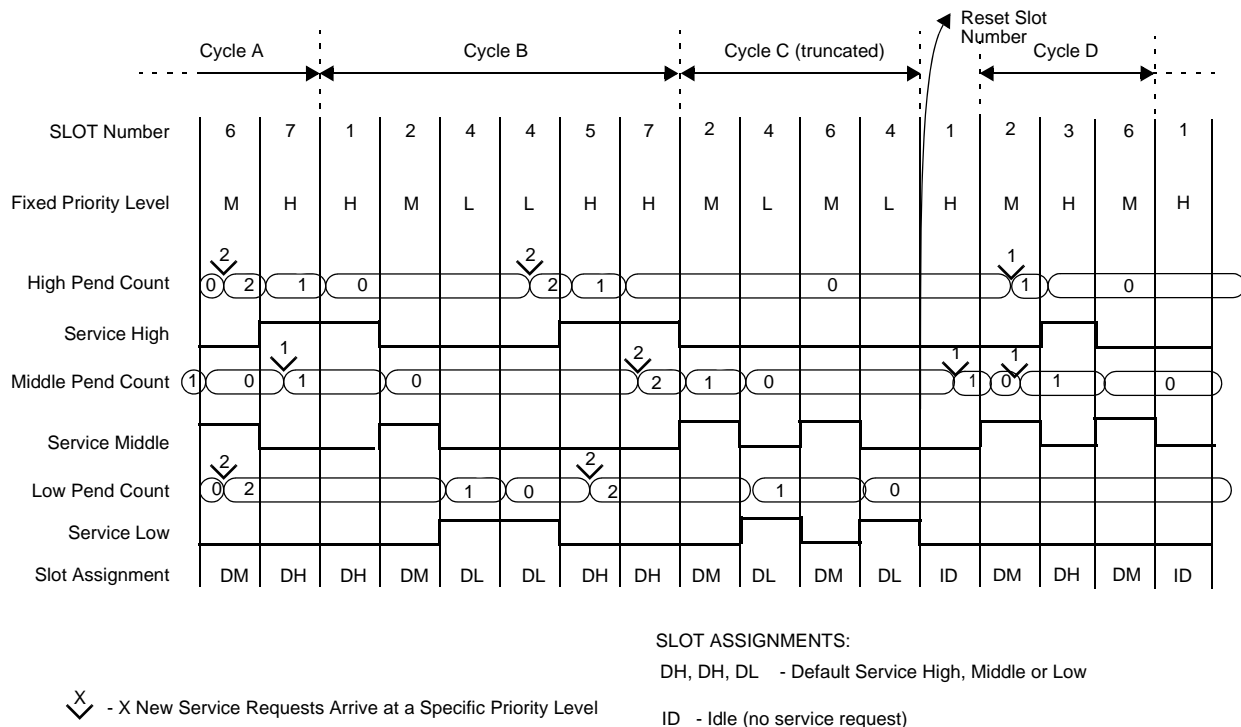

Figure 29-29. Priority Passing Disabling Example

29.3.3.2.3 Secondary Scheme - Priority Among Channels on the Same Level

Because channels can randomly request service, channels having the same priority level will inevitably request service simultaneously. A secondary scheme prioritizes these requests. The Scheduler services channels on each of the three priority levels, beginning with the lowest numbered channel on that level.

29.3.3.2.4 Priority Scheme Example

The overall priority scheme simultaneously incorporates both primary and secondary schemes. Combining both schemes in the following example conveys their correlation.

1. One high-priority and one low priority channels request service, while the Scheduler is in time slot one. Having its service request bit asserted, a single high-level channel is granted the time slot, which has high-level priority (primary scheme) and its service grant bit is asserted. At the end of the thread, the service grant bit is negated (no more requests of high priority level channels).
2. The Scheduler proceeds to time slot two, which has middle-level priority; however, no middle-level channel is requesting service. Priority is passed to the high level, but no high-level channel is requesting service; therefore, priority is passed again, and service is granted to the single requesting low-level channel. Once serviced, this channel's grant bit is negated (no more low-level requests).
3. The Scheduler resumes with the fixed-priority sequence on time slot three; however, no channels are requesting service. The Scheduler returns to time slot one, waiting for requests.
4. Two high-level and two middle-level channels simultaneously request service. Being in time slot one which is assigned high priority, the Scheduler finds the lowest numbered high-level channel (secondary scheme) and selects it for service. This channel's service grant bit is asserted.
5. The Scheduler continues to time slot two, which has middle priority (primary scheme), and allocates the slot to the lowest numbered middle-level channel requesting service (secondary scheme). The Scheduler notes the still unserviced middle-level channel and proceeds to time slot three.
6. Time slot three is allocated for high priority. The slot is allocated to the remaining unserviced high-priority channel, and the channel's service grant bit is asserted. The Scheduler checks again at the end of the thread. All service grant bits of high-level requested channels are asserted; therefore, all high-priority channels that requested have been allocated execution time. Under this condition, all service grant bits of the high-level serviced channels are negated. The Scheduler proceeds to time slot four.
7. Time slot four is allocated for low-priority channel; however, no low-level channel is requesting service. Priority is passed to the high level, but no high-level channel is requesting service; therefore, priority is passed again, and service is granted to the remaining middle-level channel which requests service. This channel's service grant bit is asserted. The Scheduler checks again at the end of the thread. All grant bits of middle-level requested channels are asserted; therefore, all middle-priority channels have been allocated execution time. Under this condition, all service grant bits of the middle-level serviced channels are negated. The Scheduler proceeds to time slot five. Meanwhile a low priority channel requests service.
8. Time slot five is allocated for high-priority channels, but there are no more requests from high-priority or middle priority channels. The single low-level channel which required service is granted time slot five. Once serviced, the channel's service grant bit is asserted. Next, the service grant bit is negated (no more requests of low priority level channels).
9. The Scheduler resumes with the fixed-priority sequence on time slot six; however, no channels are requesting service. The Scheduler returns to time slot one and waits for requests.

29.3.3.3 Time Slot Latency

Latency is the amount of time between a service request and the beginning of service on that channel. The following factors affect latency:

- Number of active channels
- Number of channels on a priority level
- Number of available time slots on a priority level
- Number of microcycles required to execute a thread of a Function
- Number of SDM accesses during execution of a Function thread
- eTPU clock frequency.

Each time slot may require a different number of microcycles, depending on the thread of a Function to be executed. This variation is shown in [Figure 29-30](#).

For more details on latency evaluation, see [Section 29.4.2, Estimating Worst Case Latency](#).

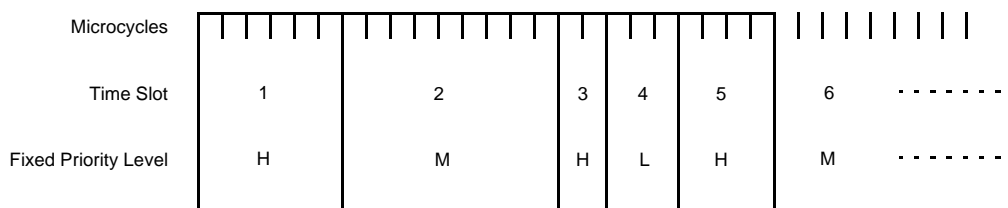

Figure 29-30. Time-Slot Variation

29.3.4 Parameter Sharing and Coherency

SDM can be concurrently accessed by Host and Microengines (two in a Dual eTPU Engine system). In general, there is no guaranteed order by which a group of parameters is accessed, which may lead to a lack of internal consistency if two or more related parameters are read when only part of them is updated.

eTPU provides mechanisms to guarantee parameter coherency. The most generic mechanisms for Host-eTPU coherency, suitable for any number of parameters, are:

- the use of Transfer Service Thread mechanism.
- the mailbox (or “software semaphore”) mechanism.

These mechanisms, described in [Section 29.4.1, Multiple Parameter Coherency Methods](#), use microcode to transfer parameters from temporary buffers in SDM to their definitive locations (or vice-versa). These methods have the disadvantage of wasting processing and code memory resources.

eTPU also provides a **Coherent Dual-parameter Controller - CDC** - mechanism. It is used by Host to coherently transfer pairs of parameters from/to a parameter buffer located on SDM to/from the locations on SDM where parameters are accessed directly by the channels. Coherency is guaranteed by SDM access arbitration. Although limited to two parameters only, it has lower latency and wastes no microengine resources¹. CDC usage is described in [Section 29.3.4.2, Coherent Dual-parameter Controller - CDC](#).

For parameters shared by both Engines, eTPU provides **hardware semaphores**. Coherency is assured given the semaphores are used to prevent concurrent access to the changing parameters. Microengine can request semaphores using specific microinstructions.

Neither Host nor CDC have access to the hardware semaphores, but they can be combined with microcode transfer mechanisms if Host must coherently access parameters which are also shared by both Engines.

29.3.4.1 Host Side Atomic Access

Host side atomic accesses can be achieved by either of following ways:

- for one parameter, the SDM should be accessed by 32-bit-wide data transfers to ensure coherency
- for two parameters only, using the Coherent Dual Parameter Controller.
- indirectly, for any number of parameters, by requesting microcode to coherently access SDM in its behalf. The host side atomicity problem becomes, then, a microengine side atomicity problem. Some methods that use this approach to achieve coherency are described in [Section 29.4.1, Multiple Parameter Coherency Methods](#).

29.3.4.2 Coherent Dual-parameter Controller - CDC

Dual-parameter coherency is supported by a Coherent Dual-parameter Controller hardware - CDC, which contends with microengine for SDM access. CDC atomically transfers, upon Host's command, two parameters from one area of the SDM to another. One area is a temporary (buffer) area, where the two parameters are directly read or written by the Host. This temporary area has to begin in an SDM address multiple of 2 words, and the two parameters must be sequential. The other area is the channel parameter area where the microcode normally accesses the parameters, usually with the channel relative address mode (see the *eTPU Reference Manual* for details). In this area, the parameters transferred by CDC don't have to be sequential. A transfer from the temporary area to the channel area, when the Host sends data to the channel, is called a **write transfer**. Inversely, in a **read transfer** the parameters are copied from the channel area to the temporary area (channel to Host).

Coherency is guaranteed by the SDM access contention rules implemented in the SDM arbiter. CDC transfers are coherent in respect to the two Engines, so the target parameters in the channel area may be shared by channels on them both. During CDC operation, the Host may suffer from 3 up to 11 eTPU clocks wait states¹, and the Microengine(s) may suffer up to 2 microcycle wait-states². CDC accesses are atomic with respect to Microengine(s) accesses to the SDM. Even when neither engine is in TST, CDC may suffer up to 4 eTPU clock internal wait-states from SDM arbiter, meaning 9 slave wait-states to Host, so that it does not break atomic back-to-back accesses from microengine(s). CDC also cannot break TST preload accesses. Host can initiate CDC back-to-back transfers: there is no need of idle slave cycles between two transfers.

1. A microengine access to the SDM in the moment CDC is performing the transfer may suffer a maximum of two wait-states.
1. The maximum number of Host wait states on CDC occurs when both microengines overlap their TSTs, delayed 3 eTPU clocks from each other.
2. One microcycle takes two eTPU clocks. Microengines get wait-states in multiples of microcycles, while Host and CDC wait-states are multiples of eTPU clocks.

29.3.4.2.1 CDC Programming

The Coherent Dual-parameter Controller Register (see [Section 29.2.5.2, ETPUCDCR - eTPU Coherent Dual-Parameter Controller Register](#)) is used to configure and initiate CDC transfers between the temporary area and channel parameter area. Host asserts STS bit in order to start the data transfer. CDC then contends for the SDM and starts the transfer. When the data transfer is complete, STS returns to 0. Host receives wait-states for writing STS=1 while CDC contends for SDM and during the transfer. The write access ends when CDC finishes the transfer. Host receives wait-states during the CDC transfer. If Host writes ETPUCDCR with STS=0 or does not write the STS byte, the CDC transfer does not occur. CDC programming can be summarized as follows:

1. If it is a write transfer, i.e., from Host to channel, write the two parameters into temporary area.
2. Write ETPUCDCR with STS=1 and the remaining CDC programming parameters: parameter width (32 or 24 bits, field PWIDTH), transfer direction (read or write, field WR), temporary parameter area base address (field PBBASE), and the absolute addresses of the parameters to be transferred (concatenation of the fields CTBASE and PARM0/1).
3. If it is a read transfer, i.e., from channel to host, read the two parameters from the temporary area into Host memory/registers.

29.3.4.3 SDM Arbitration

Up to four entities can access SDM:

- two Microengines (in a dual eTPU Engine system)
- the Coherent Dual-parameter Controller (CDC)
- the Host CPU (direct memory-mapped access)

The following rules specify the access priorities for contended access. They keep compatibility with the TPU3 dual parameter access atomicity, but only between the microengine and CDC (not Host accesses through slave bus).

1. Microengine accesses from the two eTPU Engines are interleaved between each other, but not with Host or CDC accesses;
2. The eTPU microengine(s) gives priority for SDM accesses to either the Host CPU or the CDC under any of the following conditions:
 - a. the microengine has completed accessing the second parameter in a back-to-back SDM access¹.
 - b. the SDM was not accessed during the last arbitration slot for the microengine and the host does not lose the access to the other engine in the current arbitration slot².
 - c. CDC is transferring data, after its first (read) access. Note that the CDC can be in middle of a data transfer of another pair of parameters, unrelated to the ones that microengine tries to access.
3. The eTPU microengine takes priority for SDM accesses under either of the following conditions:
 1. If microengine tries to access the SDM in the following microcycles, the third and fourth consecutive accesses are considered the first and second of a new back-to-back dual access.
 2. The microengine access slot is between its own T4 and T2 edges.

- a. the Host CPU or CDC has done a data transfer during the last access arbitration slot for the engine². Also, the Host CPU does not hold a pending access against the other eTPU microengine.
- b. the microengine is arbitrating for the access of its second parameter in a back-to-back access¹. All pairs of back-to-back parameter accesses are coherent with respect to Host and CDC (not to the other microengine).

The direction (read or write) of any individual access by Host or microengine is irrelevant to the arbitration. The use of Normal or PSE SDM area by the Host is also irrelevant to the arbitration.

The first parameter preloading in a TST is considered first access by the arbiter, regardless of any access made at the END microinstruction of the previous thread, i.e.: the last access of a thread and the first preload are never considered a back-to-back access. On the other hand, the TST preload accesses are considered back-to-back and are, therefore, atomic with respect to Host or CDC.

NOTE

The Zero SDM operation (see the *eTPU Reference Manual* for details) is considered an SDM access for arbitration purposes both on writes and reads; the fact that read SDM data is discarded is irrelevant for arbitration.

29.3.4.4 Enhanced Digital Filter - EDF

The EDF eliminates passing of signal transitions which are caused by noise. Its purpose is to eliminate false transition service requests caused by noise pulses which are shorter than a programmed width.

The EDF has three modes of operations, selected by the CDFC field in the ETPUECR register (see [Section 29.2.5.5, ETPUECR - eTPU Engine Configuration Register](#)). These modes offer selections of trade-off between noise immunity and signal latency. CDFC also allows the filter to be bypassed. [Table 29-19](#) gives an example of minimum detected signal pulse and maximum filtered noise pulse in the three EDF operation modes. In Angle Mode, if AM=01, the EDF in channel 0 is replaced with the digital filter and synchronizer of the TCRCLK signal. In this mode, channel 0 works in combination with the Angle Counter logic, and their operation is fully synchronized.

Following subsections provide the functional description of the eTPU channel digital filter.

29.3.4.4.1 Two-Sample Mode

In this mode the EDF works like the TPU2/3 digital filter. It uses the filter clock which is the eTPU clock divided by (2, 4, 8,..., 256) as a sampling clock. The filter clock is selected by the FPSCK field in the ETPUECR - Engine Configuration Register (see [Section 29.2.5.5, ETPUECR - eTPU Engine Configuration Register](#)). The EDF compares two consecutive samples. If both samples have the same value, the input signal state is updated. Note that when the FPSCK field selects the eTPU clock divided by two, the EDF works like the TPU1 four-clock digital filter.

29.3.4.4.2 Three-Sample Mode

In this mode, like in the TPU2/3 mode, the EDF uses the filter clock as a sampling clock. The EDF compares three consecutive samples. If all three samples have the same value, the input signal state is updated.

The Three-Sample mode gives more signal latency than the Two-Sample mode, but also better noise immunity and better ratio between minimum detected signal pulse to maximum filtered noise pulse. When a certain filter clock frequency is selected for Two-sample mode, double filter clock frequency can be selected to get better latency in Three-sample mode.

29.3.4.4.3 Continuous Mode

In this mode the EDF compares all the values sampled at the rate of eTPU clock divided by two, between two consecutive filter clock pulses. If the signal is continuously stable for the entire digital filter clock period (i.e all the samples have the same signal value), the input signal state is updated.

This method gives the same latency and the same ratio between minimum detected signal pulse to maximum filtered noise pulse, as the Two-Sample mode, as long as there is no noise. Each sampled noise delays the signal transition detection by at least a whole digital filter clock period.

The Continuous mode gives the best noise immunity by comparing multiple samples of the noise. On the other hand, when a short noise pulse appears in the middle of the filter clock period at the same time of a real signal transition, the Continuous mode may reject a real signal transition and delay the response to the first filter clock period in which the signal is continuously stable. This may add to the latency and also to the minimum detected signal pulse in a noisy environment.

29.3.4.4.4 Bypass Mode

In bypass mode the signal that feeds the edge detection comes directly from the output of the synchronizer, not filtered.

29.3.4.4.5 Filter Clock Prescaler

The TCRCLK signal and each channel configured as an input have an associated synchronizer followed by a digital filter connected to the signal that samples signal transitions. After reset, the digital filter filters out high and low pulse widths smaller than the period of two eTPU clocks with ETPUECR bit FCSS=0, or 1 eTPU clock with FCSS=1, preventing these transitions from being input to the transition detect logic. For FPSCK=0 and FCSS=0, the synchronizer and digital filter are guaranteed to pass pulses that are as wide as or wider than four eTPU clocks, meaning a minimum period of 8 eTPU clocks. These figures are halved by setting FCSS=1. By changing the FPSCK field in register ETPUECR the user can select a lower clock rate for the filter signal to define wider valid pulses and filter out wider noise pulses. The filter prescaler clock control is a division of the eTPU clock. To guarantee pulse detection by the digital filter, the pulse must cover at least the stated number of samples at the filter clock rate. For example, a two sample digital filter must sample two points in the pulse to detect it. [Table 29-19](#) shows the minimum guaranteed detected pulse width and the maximum filtered noise pulse width. The table refers only to the digital filter operation. The external pulses may have to be wider (to ensure detection) or narrower (to ensure filtering) depending on the rise/fall delay differences in the MCU receivers and internal logic.

Delays introduced by synchronizer, filter and edge detection logic are explained in the *eTPU Reference Manual*.

Table 29-19. Pulse Widths and Delays

| Filter Control (FPSC) | | Filter Clock Period ¹ | Min. Width Guaranteed Detected / Max. Width filtered (Min. Filter Delay / Max. Filter Delay) ¹ | |
|-----------------------|------------|----------------------------------|---|--|
| FCSS = 0 | FCSS = 1 | | Two-Sample or Continuous Mode | Three-Sample or Integrator ² Mode |
| not avail. | 000 | 1 | 2 / 1 (2 / 3) | 3 / 2 (3 / 4) |
| 000 | 001 | 2 | 4 / 2 (3 / 3) | 6 / 4 (5 / 5) |
| 001 | 010 | 4 | 8 / 4 (5 / 7) | 12 / 8 (9 / 11) |
| 010 | 011 | 8 | 16 / 8 (9 / 15) | 24 / 16 (17 / 23) |
| 011 | 100 | 16 | 32 / 16 (17 / 31) | 48 / 32 (33 / 47) |
| 100 | 101 | 32 | 64 / 32 (33 / 63) | 96 / 64 (65 / 95) |
| 101 | 110 | 64 | 128 / 64 (65 / 127) | 192 / 128 (129 / 191) |
| 110 | 111 | 128 | 256 / 128 (129 / 255) | 384 / 256 (257 / 383) |
| 111 | not avail. | 256 | 512 / 256 (257 / 511) | 768 / 512 (513 / 767) |

¹ This table shows pulse widths and delays in number of periods of the eTPU clock.

² Integrator mode is available for TCRCLK filtering only, see [Section 29.3.5.5, TCRCLK Digital Filter](#).

NOTE

If the ETPUTBCR field TCRCF selects the filter clock of the channels (see [Section 29.2.6.1, ETPUTBCR - eTPU Time Base Configuration Register](#)), the TCRCLK filter will be clocked as if FCSS=0, always dividing eTPU clock /2 using FPSC, regardless if FCSS is 0 or 1.

29.3.5 Time Bases

Each eTPU engine has two Time Counter Registers, TCR1 and TCR2. They provide 24-bit time bases, shared by all 32 channels. TCR1 can also work at full-speed eTPU clock, when ETPUTBCR[TCR1CS]=1. Both TCR1 and TCR2 values can be imported from or exported to the STAC bus. For information on STAC bus protocol and definition of STAC modules refer to IPI STAC and [Section 29.3.5.3, STAC Interface](#).

The TCR2 counters between the two Engines are out of phase by 1 eTPU clock, even when Time Bases are shared between them through STAC.

29.3.5.1 Timer Count Register 1 - TCR1

TCR1 can be used in the following modes:

- Internally Clocked Mode
- Externally Clocked Mode
- STAC Bus Client Mode

The host program can read TCR1 time base through the ETPUTB1R (see [Section 29.2.6.2, ETPUTB1R - eTPU Time Base 1 \(TCR1\) Visibility Register](#)).

The TCR1 bus runs through all the local engine channels

29.3.5.1.1 Externally Clocked Mode

TCR1 can be driven externally by the TCRCLK input, after the digital filter. The TCR1 clock source is configured by the TCR1CTL bit, as shown in Figure 29-31. For more information on clock source selection, please refer to Section 29.2.6.1, ETPUTBCR - eTPU Time Base Configuration Register.

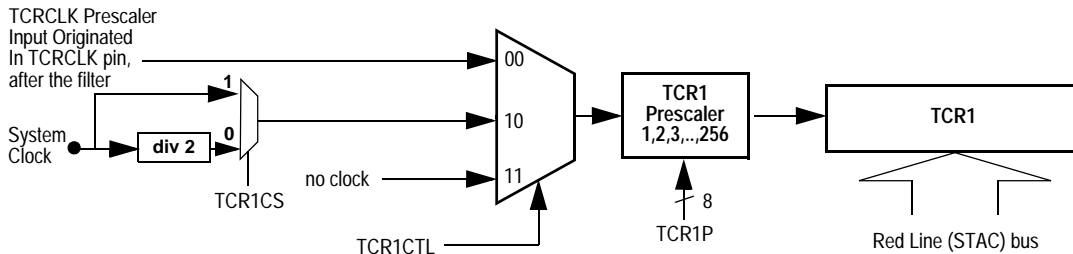

Figure 29-31. TCR1 Clock Selection

29.3.5.1.2 Internally Clocked Mode

TCR1 can be driven by the eTPU clock or eTPU clock divided by 2, before the prescaler. TCR1CTL can also be used to freeze TCR1 clock independently of TCR2 (unlike GTBE).

29.3.5.1.3 TCR1 Clock Prescaling

Any clock source selected by TCR1CTL is prescaled by a factor of 1 to 256, selected by ETPUTBCR field TCR1P. For more information on prescaler configuration refer to Section 29.2.6.1, ETPUTBCR - eTPU Time Base Configuration Register. The TCR1 Prescaler resets when etpu_gtbe_in is negated. After reset, it starts counting up to TCR1P when etpu_gtbe_in is asserted. When TCR1 increments (etpu_gtbe_in=1), the prescaler starts a new count and the new TCR1P becomes effective. When TCR1 is written by microcode, the prescaler is reloaded with TCR1P and it becomes effective, if etpu_gtbe_in is asserted.

29.3.5.1.4 STAC Bus Client Mode

In this mode the TCR1 register is continuously updated from the STAC bus, and the clock selection and prescaling logic becomes ineffective. It is not writable by the microcode, and when read, it reflects the STAC bus imported value. The use of EAC is not allowed in client mode. This mode is configured through the register ETPUREDCCR (see Section 29.2.6.4, ETPUREDCCR - eTPU STAC Configuration Register).

29.3.5.1.5 STAC Bus Server Mode

TCR1 bus can be exported to the STAC bus as a server, providing time information to other peripherals. This mode is configured through the register ETPUREDCCR (see Section 29.2.6.4, ETPUREDCCR - eTPU STAC Configuration Register).

29.3.5.2 Timer Count Register 2 - TCR2

The TCR2 is a 24-bit counter which can be used in the following modes:

- Pin Transition Mode: Count the rise, fall or both transitions of TCRCLK signal.
- Angle Clock Mode: Count internal tooth angle in combination with the eTPU Angle Counter (EAC) hardware which implements an Angle PLL, and generates angle information to the channels. This mode is targeted for angle based applications.
- STAC Bus Client Mode: TCR2 is driven by an external source (see Section 29.3.5.2.4, STAC Bus Client Mode Section , When eTPU clock divided by two is selected, the synchronizer and the digital filter are guaranteed to pass pulses that are wider than four eTPU clocks (two filter clocks). Otherwise the TCRCLK is filtered with the same filter clock as the channel input signals. For details on TCRCLK and channels digital filter control refer to Section 29.2.6.1, ETPUTBCR - eTPU Time Base Configuration Register and Section 29.3.4.4, Enhanced Digital Filter - EDF.).
- Gated Mode: Count with rate derived from the eTPU clock divided by eight. The TCRCLK signal is used to gate this count, enabling pulse accumulator operations.
- Internally Clocked Modes: TCR2 is driven by internal clock, with count rate of eTPU clock divided by eight.

All clock sources pass through a prescaler. In addition, the TCR2 count can be originated from the EAC which is a hardware angle clock and angle counter. Figure 29-32 shows the diagram for TCR2 clock control. When TCR2 is not driven by the EAC or STAC, the ETPUTBCR field TCR2CTL selects the clock source, also allowing TCR2 to be frozen independently of TCR1 (see Section 29.2.6.1, ETPUTBCR - eTPU Time Base Configuration Register). When in Angle Mode, TCR2CTL selects the TCRCLK edge sensitivity.

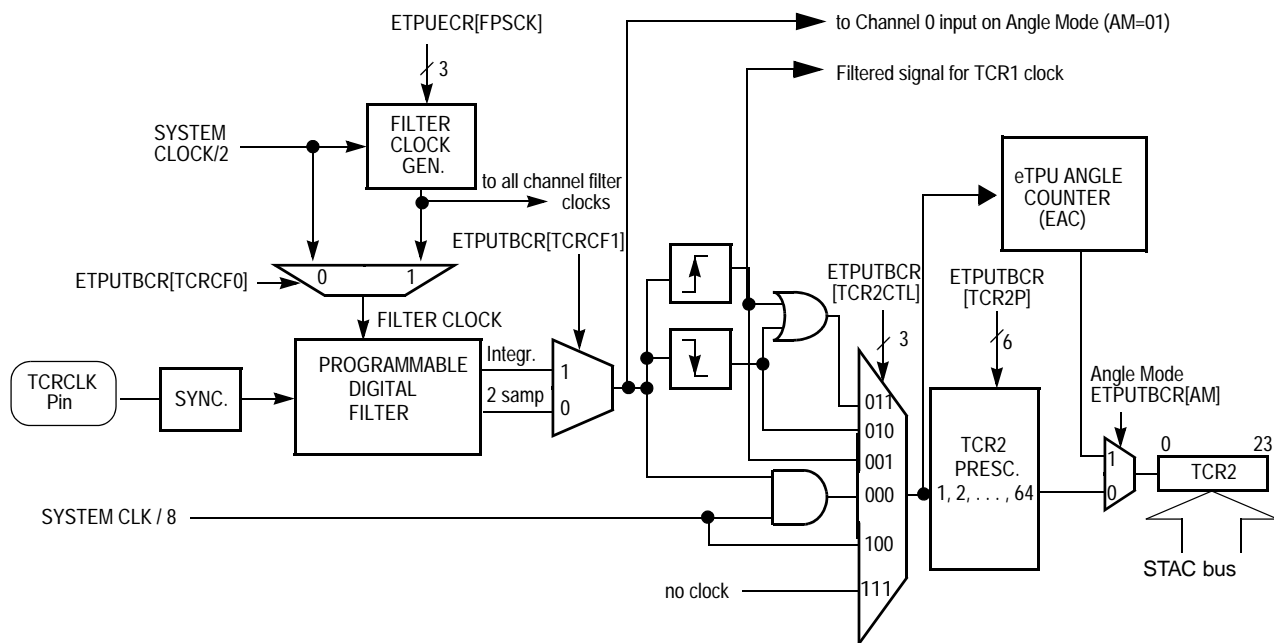

Figure 29-32. TCR2 Clock Control

The TCRCLK signal input is passed through a synchronizer and a programmable digital filter. In Angle Mode with AM=01, synchronizer and filter are also used in Channel 0, replacing its input synchronizer and filter, to get the same timing in the EAC and Channel 0. The TCRCLK synchronizer is an improved

filter that provides best latency while maintaining proper noise filtering (see [Section 29.2.6.1, ETPUTBCR - eTPU Time Base Configuration Register](#) field TCRCF[0:1] — TCRCLK Signal Filter Control).

The TCR2 bus runs through all the local engine channels

The TCR2 value is readable to the host through the ETPUTB2R register (refer to [Section 29.2.6.3, ETPUTB2R - eTPU Time Base 2 \(TCR2\) Visibility Register](#)). When the TCR2 bus value is imported from the STAC bus (STAC client mode), TCR2 is not writable by the microcode, and read access from the microcode or from the host reflect the imported TCR2 value.

29.3.5.2.1 TCR2 Clock Prescaling

Except in Angle Mode, any clock source selected by TCR2CTL is prescaled by a factor of 1 to 64, selected by ETPUTBCR field TCR2P. For more information on prescaler configuration refer to [Section 29.2.6.1, ETPUTBCR - eTPU Time Base Configuration Register](#). The TCR2 Prescaler resets when `etpu_gtbe_in` is negated. After reset, it starts counting up to TCR2P when `etpu_gtbe_in` is asserted. When TCR2 increments (`etpu_gtbe_in=1`), the prescaler starts a new count and the new TCR2P becomes effective.

The counter that divides the eTPU clock by 8 before the prescaler also resets when `etpu_gtbe_in` is negated, or when TCR2 is written by microcode.

29.3.5.2.2 TCR2 Gated Mode

TCR2 Gated mode is selected in field TCR2CTL of register ETPUTBCR. In this mode the TCRCLK signal enables or disables transfer of the eTPU clock divided by 8 to the TCR2 prescaler. By programming the prescaler, TCR2 can run at rates from eTPU clock divided by eight down to eTPU clock divided by 512, in steps of eight eTPU clock divisions. For more information refer to [Section 29.2.6.1, ETPUTBCR - eTPU Time Base Configuration Register](#).

29.3.5.2.3 TCR2 Signal Transition Modes

These modes are selected when the TCR2CTL field in ETPUTBCR is set to rise, fall or “rise-and-fall”. In these modes the TCRCLK signal is the TCR2 clock source, and its maximum transition rate depends on the TCRCLK digital filter mode of operation. The TCRCLK digital filter can be programmed to use the eTPU clock divided by two, or use the same filter clock of the channels, controlled by the TCRCF field in ETPUTBCR. It contains an up-down counter which operates as a digital integrator, optimizing signal latency in the selected mode and clock rate.

When eTPU clock divided by two is selected, the synchronizer and the digital filter are guaranteed to pass pulses that are wider than four eTPU clocks (two filter clocks). Otherwise the TCRCLK is filtered with the same filter clock as the channel input signals. For details on TCRCLK and channels digital filter control refer to [Section 29.2.6.1, ETPUTBCR - eTPU Time Base Configuration Register](#) and [Section 29.3.4.4, Enhanced Digital Filter - EDF](#).

29.3.5.2.4 STAC Bus Client Mode

In this mode the TCR2 register is continuously updated from the STAC bus, and the clock selection and prescaling logic becomes ineffective. It is not write accessible for the microcode, and when read, it reflects

the STAC bus imported value. The use of EAC is not allowed in client mode. This mode is configured through the register ETPUREDCCR (see [Section 29.2.6.4, ETPUREDCCR - eTPU STAC Configuration Register](#)).

29.3.5.2.5 STAC Bus Server Mode

When TCR2 bus is exported to the STAC bus as a server, it can provide either time or angle bus to other peripherals, according to its operation mode. This mode is configured through the register ETPUREDCCR (see [Section 29.2.6.4, ETPUREDCCR - eTPU STAC Configuration Register](#)). To provide sequential update of the STAC clients, the Angle tick rate must not be faster than the STAC programmed update rate. This requirement puts a limitation on the angle clock count rate on high rate mode. In this case the Angle and Angle Fraction accumulator (see the *eTPU Reference Manual* for details) are advanced at rate of eTPU clock divided by eight. Therefore, the STAC update rate for the Angle Bus must not be slower than eight eTPU clocks.

29.3.5.2.6 TCR2 Bus in Angle Clock Mode

In this mode the TCR2 counter operates as part of the eTPU Angle Counter (EAC). The TCR2 bus value reflects this angle representation in which it counts Angle Ticks. Angle Mode is selected when the AM bit is set in ETPUTBCR.

Note that when TCR2 works in Angle Mode, it does not count directly from the TCR2 clock input which indicates tooth signal transition. Its Angle counter is controlled by the Count Control and High Rate logic (see the *eTPU Reference Manual* for details), which provides the interpolated pin position, and handle cases of missing tooth, acceleration, de-acceleration and mechanical corrections.

The EAC uses the TCRCLK signal to get the tooth transition indications. The TCR2CTL field in ETPUTBCR has to be set for the appropriate tooth edge detection rise, fall, “rise-and-fall” or none. TCR2 count clock comes from the EAC control and not directly from the physical tooth. This way the EAC control processes the signal transitions and handles missing teeth and flywheel mechanical corrections. Note that when TCR2CTL selects “none” for tooth edge selection, the TCR2 is not necessarily frozen, but can still be incremented by the EAC logic.

In Angle Mode, eTPU channel 0, 1 or 2 operation is combined with the EAC operation. When channel 0 is selected for EAC operation, the TCRCLK digital filter is used both by the EAC and by channel 0 to get full synchronization between the two logics.

The eTPU Angle Counter (EAC) logic runs continuously and updates the TCR2 Angle counter, eliminating the microcode latency in updating the TCR2 value.

29.3.5.3 STAC Interface

Both time bases TCR1 and TCR2 can be shared between the Engines and with other blocks in the same MCU. Each one of both eTPU engines can drive their time bases to the STAC (Shared Time and Count) bus, acting as a server, while any other block can capture the value into its resources and behave like a client. For further reference about the STAC bus operation refer to [Section 29.2.6.4, ETPUREDCCR - eTPU STAC Configuration Register](#).

The eTPU can export to the STAC bus or import from the STAC bus the following internal resources:

- TCR1: Can be exported to or imported from the STAC bus. TCR1 can only be imported from STAC bus when the engine is not in Angle Mode. When TCR1 is imported from the STAC bus, it becomes read-only for the microcode and reflects the imported values. For details refer to [Section 29.3.5.1, Timer Count Register 1 - TCR1](#).
- TCR2: Can be exported to or imported from the STAC bus. TCR2 can only be imported from the STAC bus when engine is not in Angle Mode. When TCR2 is imported from the STAC bus, it becomes read-only for the microcode, and reflects the imported values. When exported to the STAC bus, TCR2 can work in either Angle Mode or as a free running counter associated with the TCRCLK signal. For details refer to the *eTPU Reference Manual*.

Proper configuration of the following bits is necessary to determine what can drive the STAC bus: ETPUTBCR[AM] and ETPUREDCCR[REN2, RSC2], according to [Figure 29-20](#).

Table 29-20. STAC Bus and Host Read Sources

| AM (ETPUTBCR) | REN2,RSC2 (ETPUREDCCR) | TCR2 Bus Source (Host read of ETPUTB2R) | STAC Bus Driver |
|---------------|------------------------|---|-----------------|
| 00 | 0x (disabled) | TCR2/Time | x |
| 01, 10 or 11 | 0x (disabled) | TCR2/Angle | x |
| 00 | 11 (Server) | TCR2/Time | TCR2/Time |
| 01, 10 or 11 | 11 (Server) | TCR2/Angle | TCR2/Angle |
| 01, 10 or 11 | 10 (Client) | reserved ¹ | |

¹ STAC client configuration in Angle Mode is also not allowed for TCR1.

Note that Angle Mode is not available for STAC bus clients: configuring both at the same time brings unspecified results. When TCR2 is a stand-alone counter or a STAC Bus server, the same value that is driven to the internal TCR2 bus is also exported to the STAC bus (either Time Count or Angle).

STAC bus configuration is provided by the ETPUREDCCR bits REN1/2 and RSC1/2. REN1/2 enable the STAC interface to interact with the resource (either TCR1 or TCR2 bus). RSC1/2 configure the resource (either TCR1 or TCR2 bus) as Server or Client.

Each time base / angle count resource from each engine receives a unique 4-bit hard-wired address that identifies it as a potential server. This address is used by the STAC Controller to coordinate which resource will drive the bus at a given STAC time-slot. For any time-slot there is a server driving the bus upon selection of the STAC Controller, and there may be a client linked to that server by the ETPUREDCCR bits SRV1/2 on each Engine. When the server address on the STAC bus matches the value in SRV1/2, the client will load the STAC information into the appropriate resource. For information on eTPU STAC Bus configuration refer to [Section 29.2.6.4, ETPUREDCCR - eTPU STAC Configuration Register](#).

The eTPU does not include a STAC Controller module, which is instantiated once in the system integration.

NOTE

Setting a timebase as client of itself is not allowed.

29.3.5.4 GTBE - Global Time Base Enable

GTBE bit in ETPUMCR register enables time bases in both engines, allowing them to be started synchronously. GTBE is divided in two block interface signals: `etpu_gtbe_out` and `etpu_gtbe_in`. GTBE bit sets `etpu_gtbe_out`, and `etpu_gtbe_in` enables time bases to start. The `etpu_gtbe_out` signal can be used for synchronization between eTPU time bases and time bases from other modules. If the GTBE bit in ETPUMCR must enable only the eTPU time bases, `etpu_gtbe_out` is simply connected to `etpu_gtbe_in`. These two cases are shown in [Figure 29-33](#). Synchronization logic can be as simple as an OR or an AND logic gate.

Once `etpu_gtbe_in` transitions to 1, the Engine 1 Time Bases start 1 eTPU clock earlier than Time Bases in Engine 2, except when TCRCLK is selected as clock source or TCR1 when `ETPUTBCR[TCR1CS]=1`. This happens independently of prescaler values as long as they are the same for both engines, because the prescalers also freeze when `etpu_gtbe_in = 0`. Microcode can always write to TCR1/2 registers, with either value of `etpu_gtbe_in`.

NOTE

The timebase prescalers are reset when the GTBE input is negated.

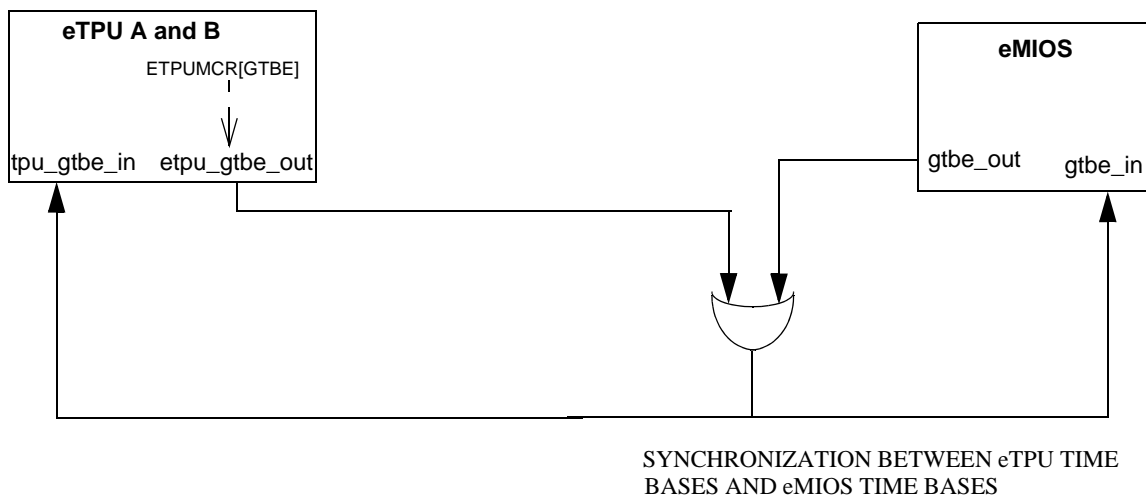

Figure 29-33. Time Base Synchronization

29.3.5.5 TCRCLK Digital Filter

The TCRCLK signal has an improved integrating digital filter with a 2-bit up-down counter. The counter counts up to 3 when a high signal level is detected, or down to 0 when a low level is detected. The signal state is updated to one when the counter stops at 3, or zero when the counter stops at 0. The field TCRCF in register ETPUTBCR (see [Section 29.2.6.1, ETPUTBCR - eTPU Time Base Configuration Register](#)) determines whether the TCRCLK signal input (after a synchronizer) is filtered with the same filter clock as the channel input signals (see [Section 29.3.4.4, Enhanced Digital Filter - EDF](#)) or uses the eTPU clock divided by 2, and also whether the TCRCLK digital filter works in integrator mode or the same two sample mode as the channel filters (see [Table 29-9](#)).

The TCRCLK filter delay and prescaling determines the minimum detectable TCRCLK pulse widths and, therefore, its maximum frequency, as shown in [Section 29.3.4.4.5, Filter Clock Prescaler](#) and [Table 29-19](#). The TCRCLK signal delay from the module input to TCR1/TCR2 incrementing or detection in the EAC logic is explained in the *eTPU Reference Manual*.

29.3.6 Safety Features

This section describes the Multiple Input Signature Calculator and memory error support features.

The Multiple Input Signature Calculator - MISC - is an SCM test feature accessible through registers ETPUMCR and ETPUMISCCMPR (see [Section 29.2.5, System Configuration Registers](#)). MISC allows SCM test “on the fly”, i.e., while eTPU is running, with no impact on eTPU functionality or performance.

Memory Error support features comprises SCM and/or SDM error detection, correction, report, and soft error fix.

29.3.6.1 SCM Test - Multiple Input Signature Calculator

The Multiple Input Signature Calculator (MISC) comprises special hardware that sequentially reads all SCM positions and calculates, in parallel, a 32-bit signature from a 32-input CRC signature calculator with the following polynomial:

$$1 + x^1 + x^2 + x^{22} + x^{31}$$

A complete description of the signature calculation procedure can be found in [Section 29.4.3, MISC Algorithm](#).

Once started by the Host the MISC runs continuously, restarting after the completion of each cycle, when it sets the ETPUMCR register flag SCMMISC (see [Section 29.2.5.1, ETPUMCR - eTPU Module Configuration Register](#)). The average time for a MISC calculation can be measured by checking SCMMISC state at regular intervals, incrementing a counter and clearing SCMMISC if it is set.

MISC accesses to the SCM array are executed if none of the engines is accessing the SCM, to avoid degradation of the microengine performance: it happens while no channel is being serviced. An ongoing MISC operation can be aborted by writing 0 to SCMMISEN.

The Host must load the register ETPUMISCCMPR (see [Section 29.2.5.3, ETPUMISCCMPR - eTPU MISC Compare Register](#)) with the expected value to be found at the end of the MISC cycle, and then start the signature calculation writing bit SCMMISEN=1 in register ETPUMCR (see [Section 29.2.5.1, ETPUMCR - eTPU Module Configuration Register](#)). MISC zeroes the signature accumulator and starts reading SCM data and calculating the signature. After last SCM position is read, MISC compares the value in signature accumulator against the value in ETPUMISCCMPR: if there is a mismatch MISC stops, a Global Exception is issued and the bit SCMMISF in register ETPUMCR assumes value 1. If no mismatch is found, MISC repeats the procedure automatically. When signature is being calculated, SCM address starts at the last SCM address and counts down to 0. The conditions for executing a MISC operation are (see also [Table 29-16](#)):

- Both microengines in idle state (no channel is being serviced) or stopped, in any combination (e.g., engine 1 idle with engine 2 stopped).
- ETPUMCR bit VIS = 0.

- ETPUMCR bit SCMMISEN=1.

Note that MISC can run regardless of SCM implementation type (RAM or ROM).

If SCMMISEN=0 or VIS=1, the MISC logic stays at its initial state, with address counter pointing to the last SCM position and accumulator reset.

29.3.7 Performance Monitoring Features

29.3.7.1 Idle Counter

The Idle Counter Register ETPUIDLER (see [Section 29.2.7.2, ETPUIDLER - eTPU Idle Register](#)) continuously counts microcycles in which the microengine is not busy with channel service. It can be used to measure the microengine utilization by rating the count measured during a period of time to the number of microcycles contained in the period. The Idle counter does not count microcycles when the engine is stopped, or is in TST or halt states.

29.4 Initialization/Application Information

29.4.1 Multiple Parameter Coherency Methods

Follows a description of two methods for coherent transfer of multiple parameters between Host and eTPU. Both methods involve the use of two parameter areas: the Transfer Parameter Area (hereafter called TPA), which is the SDM area directly accessed by the Host for reads and writes, and the Permanent Parameter Area (hereafter called PPA), which are the SDM positions where channel parameters are normally accessed by the Function microcode. Note that parameters in either TPA or PPA do not have to be in sequential addresses. TPAs and PPAs allocation are completely defined by the application, and there may be any number of them, independently of the channels.

The methods described here are not the only solutions for the coherent transfer problem, and both can coexist in eTPU and even used in combination. Also note that for transfers of a pair of parameters, the Coherent Dual-parameter Controller is faster and have less impact on both eTPU and Host performance. That said, the methods are:

- **Transfer Service:** a microengine thread transfers, upon Host Service Request, data from/to a TPA to/from a PPA. Coherency is guaranteed by the fact that a thread is atomic with respect to other threads in the same Engine, and so are its transfers. If parameters in PPA are shared by both Engines, hardware semaphores have to be used to access them.
- **Mailbox:** for Host to eTPU transfers, the microcode checks a flag, set by the host, indicating the existence of new parameter data in the TPA. It can, then, either access TPA data directly or copy it to the PPA. For eTPU to Host transfers, when microcode changes PPA, it copies them to the TPA and flags updated TPA data to Host, possibly using an Interrupt or a Data Transfer Request. The Mailbox flag is reset when data is copied: by the eTPU microcode, when it transfers TPA to PPA (possibly followed by an Interrupt); by the Host, when it reads data from the TPA. This indicates that TPA is free for another transfer.

Transfer Service has the advantage of separating the task of data transfer from the functional service thread that accesses the parameters, with less impact to the latter. Compared to the Mailbox method, however, it has bigger average latency, because the Transfer Service thread has to contend for a time slot to execute. This latency can be minimized if Transfer Service thread is assigned to a separate channel with higher priority, but even so it does not guarantee that PPA is updated before the next execution of the functional thread that uses it.

Mailbox method, on the other hand, makes the functional thread check for the existence of new data (Host to eTPU). It does not have to be responsible for the transfer, though: it may access the TPA directly, and a Transfer Service can then be used to copy data from TPA to PPA.

29.4.2 Estimating Worst Case Latency

Reliable systems are designed to work under worst-case conditions. This section explains how to estimate worst-case latency (WCL) for any eTPU function in any system. The appendix covers the following topics:

- Introduction to Worst-Case Latency
- Using Worst-Case Latency Estimates to Evaluate Performance

- Priority Scheme Details used in WCL Analyses
- First-Pass WCL Analysis
- Second-Pass WCL Analysis

The first-pass WCL analysis is based on a deterministic, generalized formula that is easy to apply. Because of the generalizations in the formula, the first analysis result is almost always much worse than the real worst case. If the desired system performance is within the limits of this first analysis, then no further analysis is required; the system is well within the performance limits of the eTPU. If the desired system performance exceeds that indicated by the first analysis, the second-pass WCL analysis should be applied. The second-pass analysis is not a generalized formula, but rather uses specific system details for a realistic worst-case estimation.

29.4.2.1 Introduction to Worst-Case Latency

NOTE

In this Appendix the latency calculation and examples refer to old TPU functions such as PWM, DIO etc. These functions use single action channels which have single transition and single match functionality. They are not optimized for the eTPU hardware enhancement which support various double action modes. These examples are for reference only. New eTPU functions which are optimized for the new hardware will impose different latency calculations.

Worst-case latency for a channel is the longest amount of time that can elapse between the execution of any two function threads on that channel. For example, if in a particular system, channel 5 is running PWM, the worst-case latency for channel 5 is the longest possible time between the execution of two PWM threads. The worst case time includes the time the execution unit takes to execute threads for other active channels, and other delays described later in this section. Refer to [Figure 29-34](#).

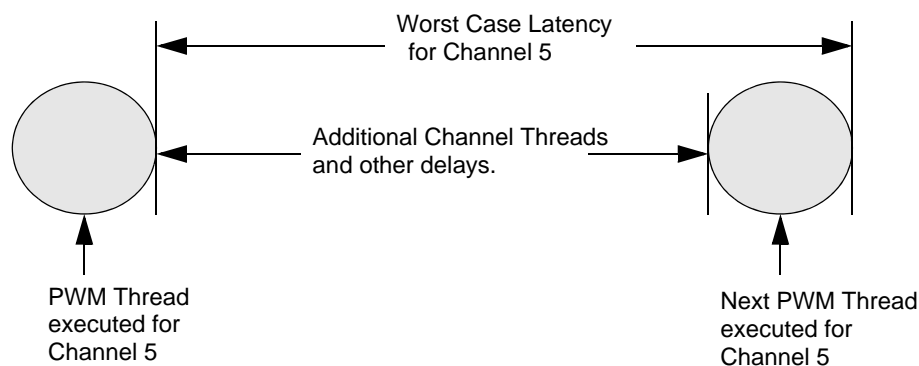

Figure 29-34. Worst-Case Latency for PWM

Worst-case latency for a channel depends both on the function running on that channel and on the activity on other channels. Since the 32 eTPU channels must all share the same execution unit, execution speed of

a particular function varies with each system. The PWM thread response is faster if there are no other active channels than if other channels are also active. In addition, changing the priority scheme and channel number assignments can change performance for a function even if the same set of functions are still active.

Each function is divided into threads, as shown in [Figure 29-35](#) (see also the *eTPU Reference Manual* for details). The eTPU Microengine executes one thread of a function at a time. For example, the Microengine might execute thread 1 of PWM, then thread 3 of DIO, then thread 2 of PWM, then thread 2 of SM, and so on. The amount of time the eTPU Microengine grants a function to execute a thread varies with the number of microcode instructions in the thread.

Since there is only one eTPU Microengine (in each eTPU Engine), the eTPU cannot actually execute the software for multiple functions simultaneously. However, the hardware for each of the channels is independent. This means that, for example, all 32 channel signals can change thread at the same moment, provided that the function software sets up the channel hardware to do so beforehand.

With Host CPU code, the system designer assigns functions to channels and initializes the functions. After initialization, functions typically run without Host intervention, except for eTPU channel interrupts to the Host to give or receive information. Most functions can run continuously with periodic servicing from the eTPU Microengine. As required, the channels request service from the eTPU Microengine, and the eTPU Scheduler determines the order in which the channels are serviced. Worst-case latency for a channel can be derived from the details of the priority scheme that the scheduler uses (see [Section 29.3.3, Scheduler](#)).

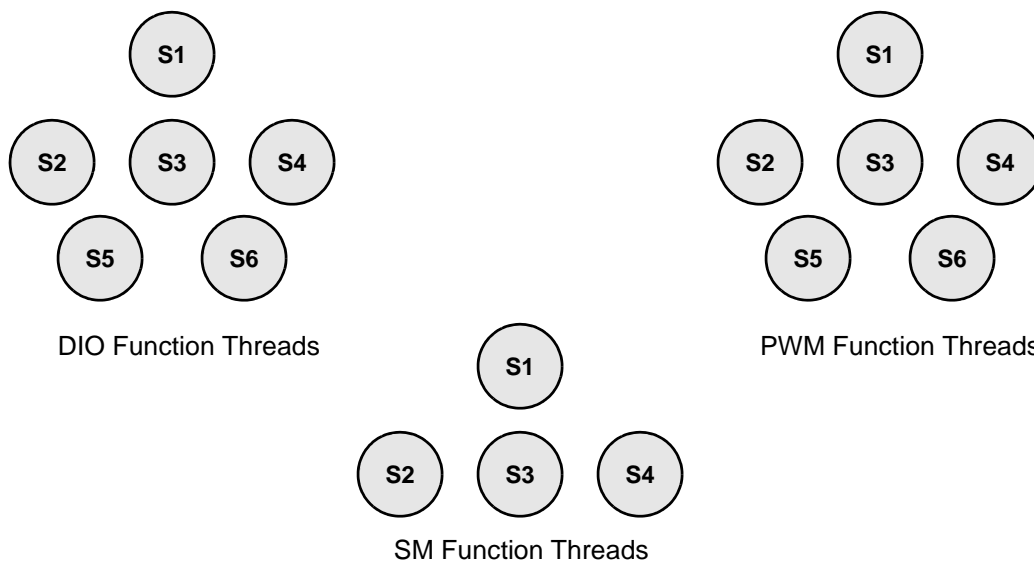

Figure 29-35. Function Threads

29.4.2.2 Using Worst-Case Latency Estimates to Evaluate Performance

Once WCL is found for a channel, the user must determine how to use this number to analyze performance. To analyze the performance of a channel running the PWM function, for example, some information about what happens in each thread is necessary.

The following example refers to old TPU PWM function, which is not optimized to the eTPU enhanced hardware. For PWM, thread 1 is the initialization thread, and threads 2 and 3 are used during normal function execution. (PWM threads 4, 5, and 6 are for special modes and will be assumed to be unused on channel 5). Thread 2 writes a time into the channel 5 match register and performs other operations that will cause the channel 5 signal to go from low to high at the time indicated in the match register (match time). At match time, the signal goes high and channel 5 requests service from the eTPU Microengine to execute thread 3. Thread 3 writes a time into the channel 5 match register and performs other operations that will cause the channel 5 signal to go from high to low at match time. At match time, the signal goes low and channel 5 requests service from the eTPU Microengine to execute thread 2. A PWM wave is kept running on the system by the eTPU executing thread 2, then thread 3, then thread 2, then thread 3, and so on.

Since the definition of worse-case latency assumes a fully loaded running system, initialization threads are not part of worst-case calculations. For the channel 5 example, the two PWM threads in [Figure 29-34](#) are thus the two normal running threads, threads 2 and 3.

[Figure 29-34](#) does not define which thread is thread 2 and which is thread 3. Since the worst-case latency derived from the first-pass analysis is the worst case between any 2 threads (not counting initialization threads), it is safe to say that the worst-case latency shown in [Figure 29-35](#) represents both the worst-case high time and the worst-case low time.

Notice in [Figure 29-34](#) that worst-case latency is drawn from the end of the execution of the first PWM thread to the end of the execution of the next PWM thread. It is drawn from end to end because the microcode instructions that make up the threads control the channel hardware. To make sure that all the microcode instructions needed to change the pin thread have been executed, it is necessary to include the execution time of the second thread.

Thread information for each function is found in the programming notes for individual TPU functions. Refer to Freescale Programming Note TPUPN00/D, *Using the TPU Function Library and TPU Emulation Mode*, for a list of available programming notes. Similar documentation will be provided for the eTPU new functions.

29.4.2.3 Priority Scheme Details Used in WCL Analysis

The user assigns functions to channel numbers and gives each active channel a priority level of high, middle, or low. The Scheduler uses the channel number and channel priority level to determine the order in which to grant service.

The scheduler allocates time slots to specific priority levels of high, middle, or low. One function thread is executed in each time slot. The length of a time slot varies according to the length of the executing thread. When fully loaded, the scheduler always assigns time slots in a seven-slot sequence (see [Figure 29-36](#)). After a seven-slot sequence is completed, another seven-slot sequence begins (see [Figure 29-37](#)). Note that in eTPU, when no service request exists, the scheduler goes to thread 1, but WCL calculation considers full load.

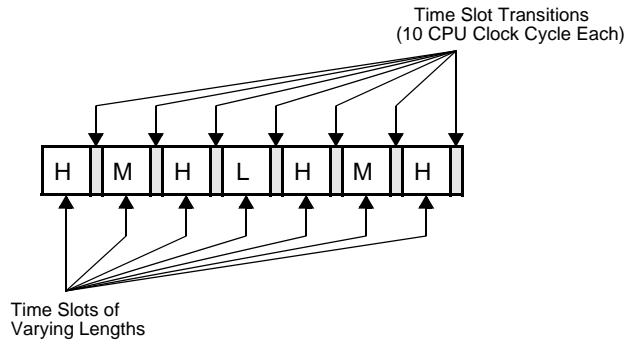

Figure 29-36. Time-Slot Sequence

This sequence scheme gives higher-priority channels more service time than lower-priority channels. High-priority channels are allocated four of seven time slots, middle-priority channels are allocated two of seven time slots, and low-priority channels are allocated one of seven time slots.

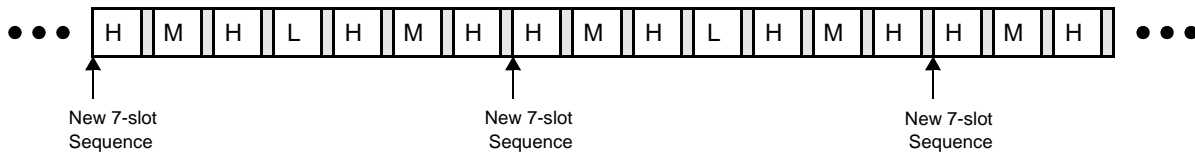

Figure 29-37. Multiple Time-Slot Sequences

29.4.2.3.1 Priority Passing

If no channel of the priority level assigned to the time slot is requesting service, the eTPU scheduler can pass priority to other levels. If no high-level channel is requesting service during a high level time slot, a middle-level channel is granted service; or, if no middle level-channel is requesting service, a low-level channel is granted service. If no middle-level channel is requesting service during a middle-level time slot, a high-level channel is granted service; or, if no high-level channel is requesting service, a low-level channel is granted service. If no low-level channel is requesting service during a low-level time slot, a high-level channel is granted service; or, if no high-level channel is requesting service, a middle-level channel is granted service. If no channel is requesting service, the time slot sequence is reset to state 1 and the scheduler idles until a request is received.

Priority passing is implemented in hardware and does not contribute to worst-case latency.

29.4.2.3.2 Time-Slot Transition

After each time slot, the eTPU must prepare for the next time slot. This preparation time between each time slot is called a time-slot transition. See the *eTPU Reference Manual* for details. Time-slot transitions can take from six up to ten eTPU clocks.

29.4.2.3.3 Channel Number Priority

If more than one channel of a priority level is requesting service, the lowest numbered channel is granted service first. For example, if channels 0, 5, and 9 are all high-level channels requesting service during a high time slot, channel 0 is granted service first. Continuing this example, if channel 0 requests service again immediately after being serviced, it is not serviced again until channels 5 and 9 are serviced. This scheme is implemented so that continuously-requesting low numbered channels do not take all the time on the eTPU execution unit and leave no time for other channels.

The scheduler uses registers to keep track of which channels have been serviced and which require servicing. Each channel has two register bit: a service request register (SRR) and a service grant register (SGR). The SRR is set when a channel requests service. After the channel has been granted service, the SGR is set and the SRR is cleared.

SGRs are not cleared individually by channel, but rather as priority level groups. The clearing of a group of SGRs begins a new cycle for that priority level. An SGR group is cleared on the condition that a channel of that priority level has just been serviced, and no other channel of that priority level is requesting service (has a set SRR) and has not been granted service (has a clear SGR).

For example, if a middle-priority channel has just been serviced (either in a middle-priority time slot or a high or low-priority time slot gained by priority passing), the SRRs and SGRs of all middle-priority channels are compared. If there is no middle-priority channel with its SRR set and SGR cleared, the scheduler clears all middle-level SGRs. If there is a middle-level channel with its SRR set and SGR cleared, the scheduler does not clear the SGR group, and the requesting middle-level channel is serviced on the next middle-level time slot (or possibly sooner by priority passing).

29.4.2.3.4 SDM Collision Rate

Most function threads read or write to the eTPU SDM at least once. Because both the eTPU Microengine and Host can access the SDM but not at the same time, the Microengine may suspend execution during the SDM access while waiting for the Host to finish accessing the SDM. At other times the Host may wait for the Microengine. Wait states can take up to two eTPU clocks, when the Host accesses the SDM directly, without using CDC. Microengine(s) wait-states must be added into the worst-case latency calculation. The system designer should estimate the percentage of SDM accesses in the system that will result in Microengine wait-states. This percentage is called the RAM collision rate (RCR). In each collision with direct Host accesses to the SDM the Microengine(s) wait for two eTPU clocks.

In eTPU the Coherent Dual-parameter Controller (CDC) may also access the SDM for atomic transfers of two parameters. eTPU Microengine may wait on this operation (if it is in service time) until the transfer is complete. CDC always transfers two parameters, making four consecutive accesses (read, write, read, write) of one eTPU clock each. The system designer should estimate the percentage of SDM accesses in the system that will result in a Microengine wait due to coherent transfer, and multiply it with the average number of eTPU clocks the Microengine waits for each transfer. This percentage is called Coherent Parameter Collision Rate (CPCR).

In addition, Microengine to Microengine multiple parameter coherent communication, using the hardware semaphores, may hold one Microengine which waits to lock the semaphore while the other Microengine is holding it. This waiting is due to a software loop, not hardware wait-states. Note that single parameter access of one Microengine does not affect the timing of the other Microengine due to SDM time interlace.

This implies that single parameter Microengine to Microengine communication does not affect the performance. The Microengine which waits for the semaphore will loop until it is freed by the other Microengine. This time depends on the eTPU application. The system designer should estimate the percentage of Microengine to Microengine coherent parameter communication that will result in eTPU semaphore loops, and multiply it with the average number of eTPU clocks the Microengine loops for each such transfer. This percentage is called CCR (Communication Collision Rate).

A 100% collision rate for a system is the theoretical worst case. In many systems, however, the RCR, CPCR and CCR would be very low, sometimes even near 0%. This is because the eTPU is an independent processor capable of servicing most function needs, so that the Host rarely needs to access the eTPU SDM. Also coherent Microengine to Microengine communication of more than one parameter may be rare. To find a realistic RCR, CPCR the system designer should evaluate the Host code and find the percentage of time it accesses the eTPU SDM with or without using the CDC. This percentage gives a good RCR and CPCR. The eTPU application provides a good estimation of CCR.

NOTE

The programming practice of polling a flag in the eTPU SDM causes a very high RCR and should be avoided in high-performance systems.

After the collision rate for a system is found, it can be applied to the WCL calculations for each channel. The system designer can use the collision percentage and the number of SDM accesses (with and without semaphores) to estimate the eTPU loop time for a function. Note that in old TPU functions CPCR and CCR are both zero.

The estimation of eTPU wait time is as follows:

Variables:

N1 = Number of simple RAM accesses in the longest thread

RCRWait = Maximal eTPU clocks wait time for simple RAM collision = 2

CPCRWait = Average eTPU clocks for Coherent Parameter Transfer (using CDC).

N2 = Number of eTPU-eTPU semaphore RAM accesses in the longest thread

CCRWait = Average eTPU clocks for Microengine-Microengine communication transfer.

Estimated Wait Time:

Function eTPU maximal wait time =

$$N1 * (RCR * RCRWait + CPCR * CPCRWait) + N2 * CCR * CCRWait$$

29.4.2.4 First-Pass Worst-Case Latency Analysis

Following is the first-pass calculation of worst-case latency for a channel. Remember that this analysis uses generalizations that usually produce a result much worse than the real worst case. If the worst-case result from the first analysis is too long for the desired performance, use the second analysis for a more realistic worst-case analysis.

29.4.2.4.1 Worst-Case Assumptions and Formula

To estimate worst-case latency for a channel, assume this worst-case condition: the channel has just been serviced in a time slot of its priority level, and all other channels in the system are continuously requesting service and have cleared SGRs. The worst-case latency is the time from the end of the channel's service until the end of the channel's next service. See [Figure 29-38](#).

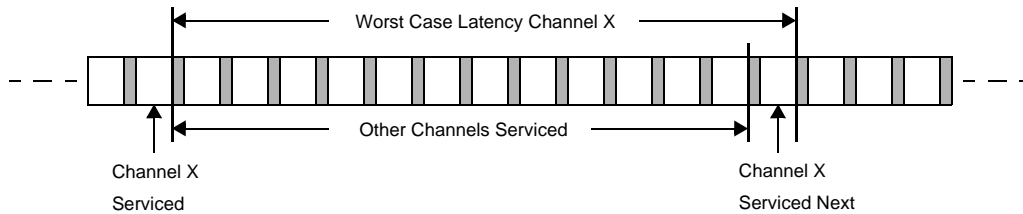

Figure 29-38. First-Pass Worst-Case Latency

To estimate worst-case latency:

- Find the worst-case service time for each active channel.
- Using the H-M-H-L-H-M-H time-slot sequence, map the channels that are granted for each time slot.
- Add time for six-clock time-slot transitions.

Finding the Worst-Case Service Time for Each Active Channel

A table for eTPU functions should list the longest threads (not counting initialization threads) for the functions, and the number of eTPU SDM accesses in the longest thread (semaphored and non semaphored). These figures will be used for estimating Microengine wait time. [Table 29-21](#) is an example for old TPU functions in which there are only simple SDM accesses. It does not take into consideration the CDC operation and Microengine to Microengine communication.

The worst-case service time for each channel is: (CPCR=CCR=0)

Longest thread + ((number of RAM accesses in longest thread+1) * RCR * 2 clocks). Note that the formula adds 1 RAM accesses for the parameter preload that occurs during TST. There are actually three accesses during TST, but only the first one can receive wait-states.

Table 29-21. Longest Threads and RAM Accesses for old TPU Functions

| Function | Longest Thread | RAM Accesses |
|----------|---------------------------------|--------------|
| DIO | 10 | 4 |
| ITC | 40 (no linking) 42 (linking) | 7 |
| OC | 40 | 7 |
| PWM | 24 | 4 |

Table 29-21. Longest Threads and RAM Accesses for old TPU Functions (continued)

| Function | Longest Thread | RAM Accesses |
|------------------|-----------------|--------------|
| SPWM | | |
| Mode 0 | 14 | 4 |
| Mode1 | 18 | 4 |
| Mode 2 | 20 (no linking) | 4 |
| | 22 (linking) | 4 |
| PMA | 94 | 8 |
| PMM | 94 | 8 |
| PSP | | |
| Angle-Angle Mode | 76 | 6 |
| Angle-Time Mode | 50 | 3 |
| ¹ SM | 160 | 21 |
| PPWA | | |
| Mode 0 | 44 ₂ | 9 |
| Mode 1 | 50 ² | 10 |
| Mode 2 | 44 | 9 |
| Mode 3 | 50 | 10 |

- ¹ Assumes one master and one slave. For each additional slave
a) Add 32 clocks and 2 RAM accesses, and
b) Add (STEP_RATE_CNT * two clocks)
- ² With one channel linked. Add two clocks for each additional channel linked.

Mapping the Channels for Each Time Slot

To determine when a channel will be serviced again, it is necessary to determine which other channels will be serviced first. Do this by assuming all channels are continuously requesting service and mapping the channels into the time-slot sequence.

Adding Time for Time-Slot Transitions

Add six eTPU clocks for time-slot transitions which occur after each time slot.

29.4.2.4.2 First-Pass Analysis Worst-Case Latency Examples

The examples in this section assume the system configuration shown in [Table 29-22](#).

Table 29-22. System Configuration Example

| Channel | Priority | Function ^{1, 2} |
|---------|----------|---|
| 0 | High | PWM (driving a DC motor) |
| 1 | Middle | PPWA (Mode 0, measuring the DC motor speed) |
| 2 | Low | DIO (Input) |

- ¹ 9% RAM Collision Rate (RCR)
- ² CPU clock rate = 40 MHz, or 25 ns per clock period

Finding the WCL for PWM on Channel 0

The following shows how to find the WCL for PWM on channel 0.

1. Find the worst-case service time for each active channel.
 - a. Longest thread of PWM is 24 CPU clocks with four RAM accesses.

$$24 + ((4 \text{ RAM accesses} + 1) * 0.09 * 2 \text{ CPU clock waits}) = 24.9 \text{ CPU clocks, rounded up to 25 CPU clocks (since there are no partial clock periods)}$$
 Channel 0 worst-case service time = 25 CPU clocks.
 - b. Longest thread of PPWA in mode 0 is 44 CPU clocks with nine RAM accesses.

$$44 + ((9 \text{ RAM accesses} + 1) * 0.09 * 2 \text{ CPU clock waits}) = 45.8 \text{ CPU clocks, rounded up to 46 CPU clocks}$$
 Channel 1 worst-case service time = 46 CPU clocks.
 - c. Longest thread of DIO is ten CPU clocks with four RAM accesses.

$$10 + ((4 \text{ RAM accesses} + 1) * 0.09 * 2 \text{ CPU clock waits}) = 10.9 \text{ CPU clocks, rounded up to 11 CPU clocks}$$
 Channel 2 worst-case service time = 11 CPU clocks.
2. Assume channel 0 has just been serviced and that channels 1 and 2 are continuously requesting service. Using the H-M-H-L-H-M-H time-slot sequence, map the channels that are granted for each time slot. See [Figure 29-39](#).

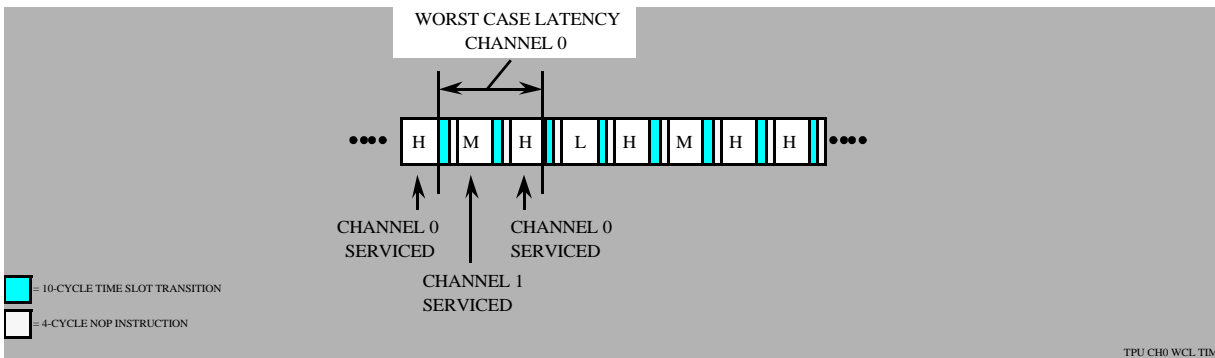

Figure 29-39. Next Servicing for Channel 0

Channel 1 will be serviced in the middle-priority time slot before channel 0 is serviced again.

3. Add time for the six-clock CPU time-slot transitions. See [Figure 29-39](#) and [Table 29-23](#).

A four-clock NOP occurs after each channel is serviced since there is one channel in each priority level, i.e., a new cycle for a priority level is started after each channel is serviced. Time-slot transitions occur after each time slot.

Table 29-23. Worst-Case Latency for Channel 0

| | |
|-----------------------------------|------------------|
| Channel 0 worst-case service time | 25 clocks |
| Channel 1 worst-case service time | 46 clocks |
| Two 6-clock time-slot transitions | 12 clocks |
| Total clocks | 83 clocks |

$$83 \text{ clocks} * 25 \text{ ns/clock} = 2075 \text{ ns}$$

Conclusion: in this system configuration PWM can run with a minimum high time or low time of 2075 ns.

Note that in double match eTPU system the PWM can be serviced once in each period, and there is no latency for minimum high time. The latency in eTPU PWM function will represent the minimum PWM period.

Finding the WCL for PPWA on Channel 1

The following shows how to find the WCL for PPWA on channel 1.

1. Find the worst-case service time for each active channel. See step 1 of previous example.
2. Assume channel 1 has just been serviced and that channels 0 and 2 are continuously requesting service. Using the H-M-H-L-H-M-H time-slot sequence, map the channels that are granted for each time slot. See [Figure 29-40](#).

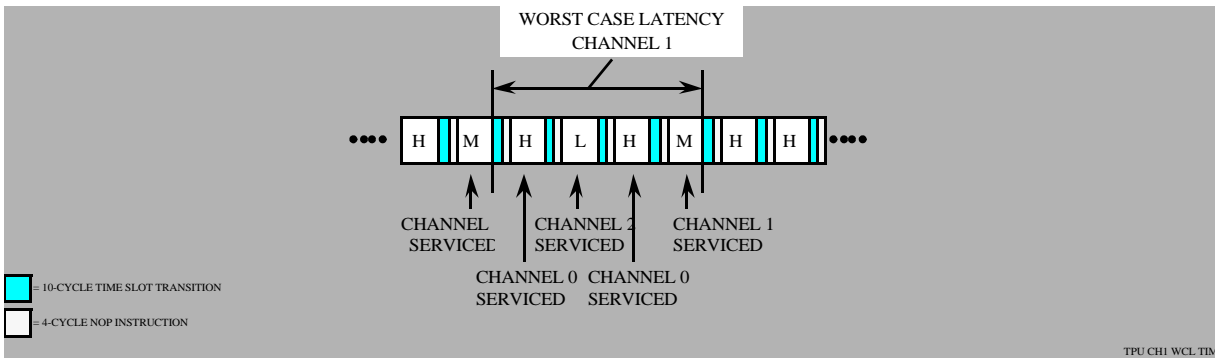

Figure 29-40. Next Servicing for Channel 1

Channel 0 will be serviced twice and channel 2 once before channel 1 is serviced again.

3. Add time for the six-clock CPU time-slot transitions. See [Figure 29-40](#) and [Table 29-24](#).

Table 29-24. Worst Case Latency for Channel 1

| | |
|--|-------------------|
| Two Channel 0 worst-case service times | 50 clocks |
| Channel 1 worst-case service time | 46 clocks |
| Channel 2 worst-case service time | 11 clocks |
| Four 6-clock time-slot transitions | 24 clocks |
| Total clocks | 131 clocks |

$$131 \text{ clocks} * 25 \text{ ns/clock} = 3275 \text{ ns}$$

Conclusion: in this system configuration PPWA can measure a period or pulse of minimum 3275 ns.

Note that PPWA function optimized for eTPU hardware can use double transition mode to measure very narrow pulses with one service after the second transition, and latency will affect only the minimum gap between two input pulses. Also the function threads would have more efficient coding.

Finding the WCL for DIO on Channel 2

The following shows how to find the WCL for DIO on channel 2.

1. Find the worst-case service time for each active channel. See step 1 of previous examples.
2. Assume channel 2 has just been serviced and that channels 0 and 1 are continuously requesting service. Using the H-M-H-L-H-M-H time-slot sequence, map the channels that are granted for each time slot. See [Figure 29-41](#).

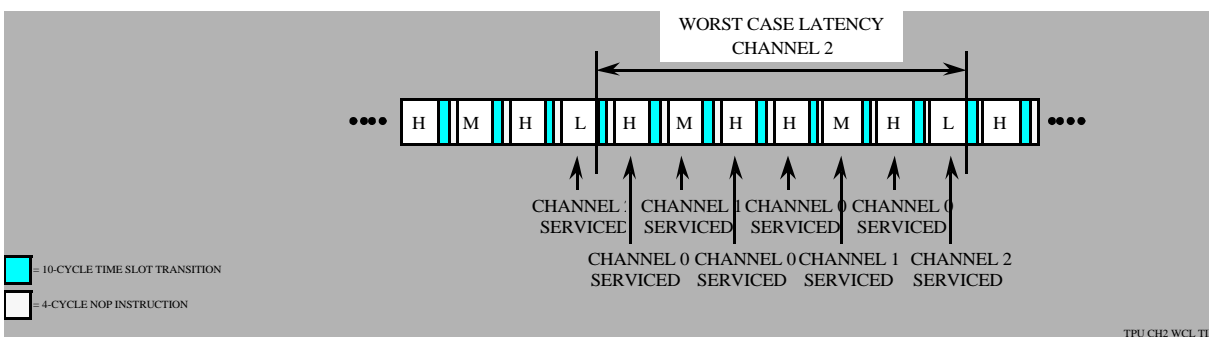

Figure 29-41. Next Servicing for Channel 2

Channel 0 will be serviced four times and channel 1 twice before channel 2 is serviced again.

3. Add time for the ten-clock CPU time-slot transitions and the four-clock NOPs. See [Figure 29-41](#) and [Table 29-25](#).

Table 29-25. Worst Case Latency for Channel 2

| | |
|---|-------------------|
| Four Channel 0 worst-case service times | 100 clocks |
| Two Channel 1 worst-case service time | 92 clocks |
| Channel 2 worst-case service time | 11 clocks |
| Seven 6-clock time-slot transitions | 42 clocks |
| Total clocks | 245 clocks |

$$245 \text{ clocks} * 25 \text{ ns/clock} = 6125 \text{ ns}$$

Conclusion: in this system configuration DIO can keep track of the input level at a minimum of every 6125 ns.

Note that DIO function optimized for eTPU hardware can use double transition mode to measure two pin transitions at a time and reduce the service time, improving the overall system performance and latency.

29.4.2.5 Second-Pass Worst-Case Latency Analysis

Following is an example of a second-pass analysis for calculating worst-case latency for a channel. The second-pass analysis is useful for higher-performance systems, since it gives a more realistic worst-case latency result than first-pass analysis.

This example uses a relatively simple system in order to illustrate the basic principles of second-pass analysis. For a more complex example of second-pass analysis, refer to Multiphase Motor Commutation TPU Function (COMM)(TPUPN09/ D).

29.4.2.5.1 Second-Pass Analysis Guidelines

Rather than use a fixed formula, a second-pass analysis relies on the application of the following guidelines.

1. The first-pass analysis makes the assumption that all channels in the system are continually requesting service. For many systems this is an unrealistic assumption. For example, if TCR1 is counting at a rate of 2 MHz (500 ns per count) and a channel is running the DIO function with a match rate of 20,000 TCR1 counts, the DIO will request service every 10 ms ($20,000 * 500 \text{ ns} = 10,000,000 \text{ ns}$ or 10 ms). It is therefore unrealistic to assume that the channel running this DIO function is continuously requesting service. Figure out a realistic service request rate for each channel. Time slots can then be mapped to each channel at the real rate of request.
2. If a function is active during system initialization but not during the high-speed running mode of the system, then that system does not need to be included in the high-speed worst-case latency calculations.
3. Use a realistic SDM collision rate.
4. Be careful when assigning functions priority levels and channel numbers. Decide which function or functions will be most difficult to make perform at the desired level. Assign those channels high priority and low channel numbers. Try different priority and channel assignments to see how it affects the system.
5. The seven-slot sequence of || H | M | H | L | H | M | H || is asymmetrical when put back-to-back with other seven-slot sequences. Note that in the following sequence there are two high-priority slots next to each other:

|| H | M | H | L | H | M | H || || H | M | H | L | H | M | H ||

6. Make sure that when mapping out channels to the sequence, you choose a worst-case slot to start the mapping. For example, when estimating WCL for a high-priority channel, do not start the mapping in the last high-priority slot in a seven-slot sequence, as that is a best case for a high-priority channel since another high-priority time slot is next.
7. Instead of always using the longest thread in the function as the worst-case thread, evaluate the threads in the function that will be used in the system and use the appropriate worst-case threads. For example, in the preceding example of first-pass analysis, the PWM was shown to be able to achieve a high time and low time of 2475 ns under worst-case conditions. This was derived using the longest PWM thread of 24 CPU clocks. This longest thread is actually thread 2, the thread that

is entered after the pin has just gone high. Thread 3, the thread that is entered after the pin has just gone low, requires only 2 CPU clocks. Therefore, in the first-pass example, the high time was correctly derived, but the low time is actually shorter than was estimated.

29.4.2.5.2 Second-Pass Analysis Example

This example requires three 50% PWM waveforms: one 5 kHz (200 ms/period) and two 50 kHz (20 ms/period), each running DC motors. (Remember that the PWM function requests service from the eTPU after each high time and after each low time, so the eTPU must handle a request every 100 ms for the 5 kHz PWM and every 10 ms for the 50 MHz PWM.)

NOTE

This example uses square waves for simplicity. Notice that to use a PWM waveform in the typical way, in which the pulse is modulated, the pulse must not be modulated in a way that violates the worst-case latency requirements.

This example also uses one DIO channel monitoring a signal level every millisecond and one PPWA channel in mode 0 monitoring the speed of the 5-kHz DC motor. The PPWA must measure periods of 5 kHz (200 ms/period).

The CPU is interrupted by the channel running the PPWA function after measuring 200 periods (every 40 ms). The interrupt service routine performs an averaging of the period accumulation and checks it against a known parameter. The interrupt service time is so short and infrequent that it is a tiny fraction of total system time. The interrupt service routine contains no polling of the SDM. Therefore a realistic RCR = 0%.

First-Try System Configuration

Try a system configuration that seems likely to work. If it does not, change priority levels or channel numbers.

The 5 kHz and 50 kHz PWMs are the most time-critical functions. Those are assigned high priority. PPWA is assigned middle priority. The DIO is low performance and is assigned low priority. Refer to [Table 29-26](#).

Table 29-26. First-Try System Configuration

| Channel | Priority | Function ^{1, 2} |
|---------|----------|-----------------------------------|
| 0 | High | PWM at 50 kHz (needs a 4-μs WCL) |
| 1 | High | PWM at 50 kHz (needs a 4-μs WCL) |
| 2 | High | PWM at 5 kHz (needs a 40-μs WCL) |
| 8 | Middle | PPWA at 5 kHz (needs a 80-μs WCL) |
| 15 | Low | DIO as input at rate of 1 ms |

¹ 0% RAM collision rate

² CPU clock rate = 40 MHz, or 60 ns per clock period

With this system configuration, worst-case service time for each active channel is determined as follows:

- a. Longest thread of PWM is 24 CPU clocks with four RAM accesses.

$$24 + ((4 \text{ RAM accesses} + 1) * 0 * 2 \text{ CPU clock waits}) = 24 \text{ CPU clocks}$$

Channels 0-2 worst-case service time = 24 CPU clocks.

- b. Longest thread of PPWA in mode 0 is 44 CPU clocks with nine RAM accesses.
 $44 + ((9 \text{ RAM accesses} + 1) * 0 * 2 \text{ CPU clock waits}) = 44 \text{ CPU clocks}$

Channel 8 worst-case service time = 44 CPU clocks.

- c. Longest thread of DIO is ten CPU clocks with four RAM accesses.

$10 + ((4 \text{ RAM accesses} + 1) * 0 * 2 \text{ CPU clock waits}) = 10 \text{ CPU clocks}$

Channel 15 worst-case service time = 10 CPU clocks.

To find the WCL for channel 0, assume channel 0 has just finished service.

Map the channels in the H-M-H-L-H-M-H sequence. See [Figure 29-42](#).

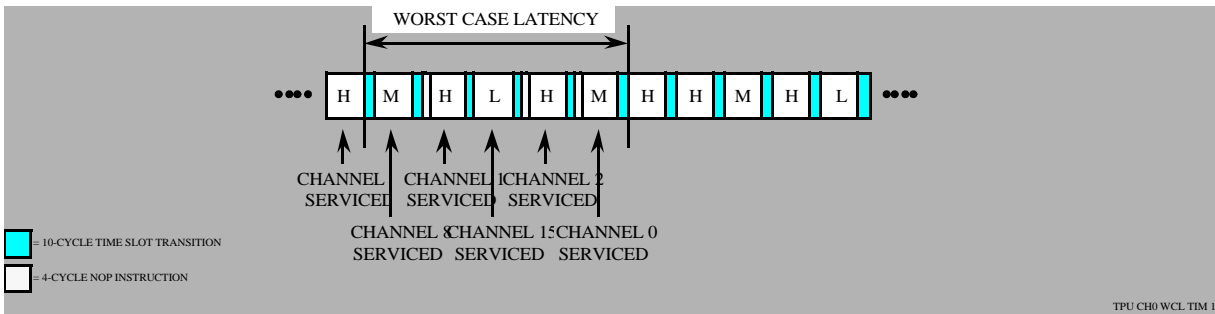

Figure 29-42. Worst-Case Latency for Channel 0 (First Try)

Conclusion: with this system configuration, worst-case latencies for channels 0 and 1 are too high (WCL for channel 1 is the same as WCL for channel 0). Try a different system configuration.

Second-Try System Configuration

The second-try system configuration is shown in [Table 29-27](#).

Table 29-27. Second-Try System Configuration

| Channel | Priority | Function ^{1, 2} |
|---------|----------|---|
| 0 | High | PWM at 50 kHz (needs a 4- μ s WCL) |
| 1 | High | PWM at 50 kHz (needs a 4- μ s WCL) |
| 2 | Middle | PWM at 5 kHz (needs a 40- μ s WCL) |
| 8 | Middle | PPWA at 5 kHz (needs a 80- μ s WCL) |
| 15 | Low | DIO as input at rate of 1 ms |

¹ 0% RAM collision rate

² CPU clock rate = 40 MHz, or 60 ns per clock period

To find the WCL for channel 0, assume channel 0 has just finished service. Map the channels in the H-M-H-L-H-M-H sequence. See [Figure 29-43](#).

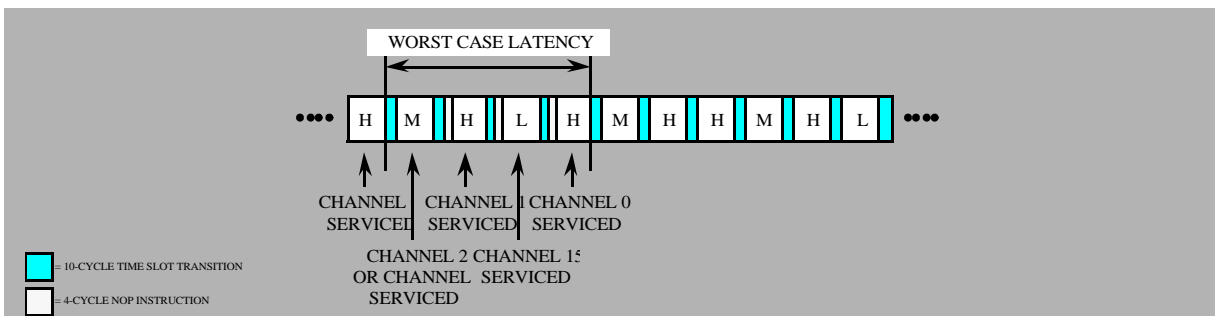

Figure 29-43. Worst-Case Latency for Channel 0 (Second Try)

Conclusion: with this system configuration, the WCL of both channel 0 and channel 1 is 3.85 ms, which is within the limit of 4 ms needed for a 50-kHz PWM.

Next, find the WCL for channel 2. Assume channel 2 has just finished service. Map the channels in the H-M-H-L-H-M-H sequence. See [Figure 29-44](#).

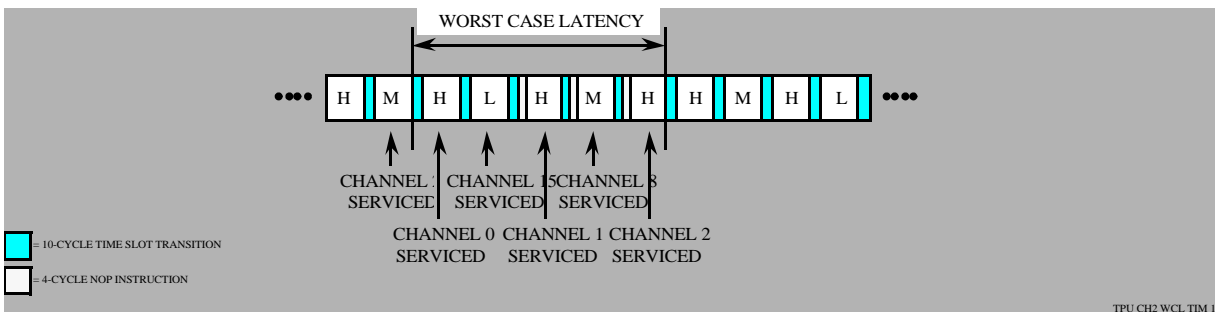

Figure 29-44. Worst-Case Latency for Channel 2

Conclusion: with this system configuration, the WCL for channels 2 and 8 is 4.7 ms, which is within the 40 and 80 ms WCL requirements.

Notice that channels 2 and 8 are well within their WCL requirements. The system could be reconfigured as shown in Table 29-28 to give channels 0 and 1 a larger margin while still keeping channels 2, 8 and 15 within their WCL requirements.

Table 29-28. Second-Try System with Channel 0 and 1 Reconfigured

| Channel | Priority | Function ^{1, 2} |
|---------|----------|-----------------------------------|
| 0 | High | PWM at 50 kHz (needs a 10-μs WCL) |
| 1 | High | PWM at 50 kHz (needs a 10-μs WCL) |
| 2 | Middle | PWM at 5 kHz (needs a 40-μs WCL) |
| 8 | Low | PPWA at 5 kHz (needs a 80-μs WCL) |
| 15 | Low | DIO as input at rate of 1 ms |

¹ 0% RAM collision rate

² CPU clock rate = 40 MHz, or 60 ns per clock period

29.4.3 MISC Algorithm

The MISC generator is based on the following polynomial:

$$G(x) = 1 + x^1 + x^2 + x^{22} + x^{31} \text{ (equivalent to feedback mask = 0x80400007)}$$

The MISC signature generation starts by clearing the MISC Accumulator value to 0 and preloading the MISC Counter with the highest SCM address. It then steps through each address decrementing the counter, reading 32 bit values and following the algorithm below:

If the least significant bit in MISC is 1 then

MISC = MISC right shifted by 1 bit

MISC = MISC XOR 0x80400007

else

MISC = MISC right shifted by 1 bit

end if

MISC = MISC XOR RAM data

The code example below shows an excerpt of C code that calculates the MISC signature for a given array of data, based on the previous algorithm:

```
#define SCM_size    (MAX_SCM_ADDRESS / 4)    /* last byte address - converted to 32-bit word */
#define POLY        0x80400007              /* G(x) = 1 + x1 + x2 + x22 + x31 */

/*****
FUNCTION : void calc_misc()
PURPOSE : This function calculates the MISC value.
INPUTS NOTES : none
RETURNS NOTES : MISC value
GENERAL NOTES : the array 'unsigned int data[]' represents the actual memory
array, organized in 32-bit words.
*****/
unsigned int calc_misc (void)
```

```

{
  int j; /* loop counter */

  unsigned int misc = 0;

  for (j = (SCM_size-1); j >= 0 ; j--) { /* SCM_size has the number of 32-bit words in SCM */

    if (misc & 0x1) {
      misc >>= 1;
      misc ^= POLY;
    }
    else {
      misc >>= 1;
    }
    misc ^= data[j]; /* data[j] is the actual 32-bit word taken from the SCM array */
  }

  return (misc); /* final signature calculated */
};

```

The value calculated by this algorithm must be loaded into register ETPUMISCCMPR prior to activating the SCM MISC calculator in eTPU. Once the MISC calculator is activated (bit SCMMISEN in register ETPUMCR is written to 1) eTPU itself will start this procedure¹ reading the SCM whenever allowed by microengine. At the end of the cycle, when all the array has been read and the SCM signature is calculated, the Host CPU can be notified via Global Exception if the MISC Accumulator does not match the value in ETPUMISCCMPR.

The average time taken by MISC to complete the signature of the whole SCM can be given by the formula:

$$\text{Average MISC period} = S / (4 * f * (1 - L))$$

where f is clock frequency, S is SCM size in bytes and L is eTPU load (as a percentage of execution clocks over a period of time, including TST clocks).

Further detail on MISC calculation can be found on [Section 29.3.6.1, SCM Test - Multiple Input Signature Calculator](#). The application note [AN2192 - Detecting Errors in the Dual Port RAM \(DPTRAM\) Module](#) is also a good source of information (although it refers to TPU) on MISC signature.

1. eTPU MISC hardware is optimized to read 32-bit words from memory and to calculate this CRC in parallel, rather than shifting one bit at a time. The actual implementation inside eTPU, although bringing to the same results, does not match exactly the algorithm shown here.



Chapter 30

External Bus Interface (EBI)

30.1 Introduction

30.1.1 Overview

The External Bus Interface (EBI) handles the transfer of information between the internal buses and the memories or peripherals in the external address space. The EBI includes a memory controller that generates interface signals to support a variety of external memories. This includes Single Data Rate (SDR) burst mode flash, SRAM, and asynchronous memories. It supports up to 4 regions (via chip selects), each with its own programmed attributes (plus 4 calibration chip-select regions).

30.1.2 Features

- 22-Bit Address bus with transfer size indication
- 16-Bit Data bus (32-bit Data Bus in muxed mode)
- Multiplexed Address on Data pins (single master)
- Memory controller with support for various memory types:
 - synchronous burst SDR flash and SRAM
 - asynchronous/legacy flash and SRAM
- Burst support (wrapped only)
- Bus monitor
- Port size configuration per chip select (16 or 32 bits)
- Configurable wait states
- Configurable internal or external transfer acknowledge ($\overline{D_TA}$) per chip select
- Support for Dynamic Calibration with up to 4 chip-selects
- Four Write/Byte Enable ($\overline{D_WE}[0:3]$) signals
- Slower-speed clock modes
- Stop and Module Disable Modes for power savings
- Optional automatic D_CLKOUT gating to save power and reduce EMI
- Misaligned access support (for chip-select accesses only)
- Compatible with MPC5xx external bus (with some limitations)

30.1.3 Signal Naming

Generic signal names like ADDR and DATA have been replaced with signal names according to the table below. Refer to the Signals chapter for the full signal names and muxing information ([Table 30-1](#) lists the function partial-signal name).

Table 30-1. Device-Specific Signal Naming

| Generic Signal Name | Equivalent Chip-level Signal Name ¹ | I/O Type | Function |
|-----------------------------|--|----------|----------------------------|
| ADDR | D_ADD[9:30] | I/O | Address bus |
| $\overline{\text{BDIP}}$ | $\overline{\text{D_BDIP}}$ | Output | Burst Data in Progress |
| CLKOUT | D_CLKOUT ² | Output | Clockout |
| $\overline{\text{CS}}$ | $\overline{\text{D_CS}}[0:3]^3$ | — | — |
| $\overline{\text{CAL_CS}}$ | | Output | Calibration Chip Selects |
| DATA | D_ADD_DAT[0:15] (through muxing D_ADD_DAT[16:31] are available) | I/O | Data bus ⁴ |
| $\overline{\text{OE}}$ | $\overline{\text{D_OE}}$ | Output | Output Enable |
| RD_ $\overline{\text{WR}}$ | D_RD_ $\overline{\text{WR}}$ | I/O | Read_Write |
| $\overline{\text{TA}}$ | $\overline{\text{D_TA}}$ | I/O | Transfer Acknowledge |
| $\overline{\text{TEA}}$ | $\overline{\text{D_TEA}}$ | I/O | Transfer Error Acknowledge |
| $\overline{\text{TS}}$ | $\overline{\text{D_TS}}$ | I/O | Transfer Start |
| $\overline{\text{WE/BE}}$ | $\overline{\text{D_WE}}[0:3]$ | Output | Write/Byte Enables |
| ALE | D_ALE | Output | Address Latch Enable |

¹ This pin function may not be the pins primary function, Refer to the Signals chapter for muxing information.

² The D_CLKOUT signal is driven by the System Clock Block outside the EBI.

³ Most of this chapter refers to CS pins (especially diagrams), but the behavior is identical for the CAL_CS pins (described in [Section 30.4.2.10, Calibration Bus Operation](#)). Only CAL_CS (D_CS at chip-level) is implemented on this device.

⁴ In Address/Data multiplexing modes, Data will also show the address during the address phase.

30.1.4 Modes of Operation

The mode of the EBI is determined by the MDIS, EXTM, and AD_MUX bits in the EBI_MCR. See [Section 30.3.1.1, EBI Module Configuration Register \(EBI_MCR\)](#) for details. Slower-speed modes, Debug Mode, Stop Mode, and Factory Test Mode are modes that the MCU may enter, in parallel to the EBI being configured in one of its block-specific modes.

30.1.4.1 Single Master Mode

In Single Master Mode, the EBI responds to internal requests matching one of its regions, but ignores all externally-initiated bus requests. The MCU is the only master allowed to initiate transactions on the external bus in this mode; therefore, it acts as a parked master and does not have to arbitrate for the bus before starting each cycle. The $\overline{\text{BR}}$, $\overline{\text{BG}}$ and $\overline{\text{BB}}$ signals are not used by the EBI in this mode, and are

available for use in an alternate function by another block of the MCU. Single Master Mode is entered when $EXTM=0$ and $MDIS=0$ in the `EBI_MCR`.

30.1.4.2 Module Disable Mode

The Module Disable Mode is used for MCU power management. The clock to the non-memory mapped logic in the EBI can be stopped while in Module Disable Mode. Logic on the MCU external to the EBI is needed to fully implement the Module Disable Mode (to shut off the clock). Internal master requests made to the external bus in Module Disable Mode are terminated with transfer error (internally, no external $\overline{D_TEA}$ assertion). Module Disable Mode is entered when $MDIS=1$ in the `EBI_MCR`.

30.1.4.3 Stop Mode

The EBI supports the SIU Halt Mode mechanism used for MCU power management. When a request is made to enter Stop Mode (controlled in device logic outside EBI), the EBI block completes any pending bus transactions and acknowledges the stop request. After the acknowledgement, the system clock input may be shut off by the clock driver on the MCU. While the clocks are shut off, the EBI is not accessible. While in stop mode, accesses to the EBI from the internal master will terminate with transfer error (internally, no external $\overline{D_TEA}$ assertion).

30.1.4.4 Slower-Speed Modes

In slower-speed modes, the external `D_CLKOUT` frequency is divided (by 2, 3, etc.) compared with that of the internal system bus. The EBI behavior remains dictated by the mode of the EBI, except that it drives and samples signals at the `D_CLKOUT` frequency rather than the internal system frequency. This mode is selected by writing a clock control register in a block outside of the EBI.

30.1.4.5 16-Bit Data Bus Mode

For MCUs that have only 16 data bus signals pinned out, or for systems where the use of a different multiplexed function (e.g. GPIO) is desired on 16 of the 32 data pins, the EBI supports a 16-bit Data Bus Mode. In this mode, only 16 data signals are used by the EBI. The user can select which 16 data signals are used (`D_ADD_DAT[0:15]` or `D_ADD_DAT[16:31]`) by writing the `D16_31` bit in the `EBI_MCR`.

For EBI-mastered accesses, the operation in 16-bit Data Bus Mode ($DBM=1$, $PS=x$) is similar to a chip-select access to a 16-bit port in 32-bit Data Bus Mode ($DBM=0$, $PS=1$), except for the case of a non-chip-select access of exactly 32-bit size.

EBI-mastered non-chip-select accesses of exactly 32-bit size are supported via a two (16-bit) beat burst for both reads and writes. See [Section 30.4.2.9, Non-Chip-Select Burst in 16-bit Data Bus Mode](#). Non-chip-select transfers of non-32-bit size are supported in standard non-burst fashion.

16-bit Data Bus Mode is entered when $DBM=1$ in the `EBI_MCR`.

30.1.4.6 Multiplexed Address on Data Bus Mode

This mode covers several cases aimed at reducing pin count on MCU and external components. In this mode, the D_ADD_DAT pins will drive (for internal master cycles) the address value on the first clock of the cycle (while $\overline{D_TS}$ is asserted).

The memory controller supports per-chip-select selection of multiplexing address/data through the BRx[AD_MUX] bit.

Address on Data bus multiplexing also supports the 16-bit data bus mode (MCR[DBM]=1) and 16-bit memories (ORx[PS]=1). The user can select which 16 data signals are used (D_ADD_DAT[0:15] or D_ADD_DAT[16:31]) by writing the D16_31 bit in the EBI_MCR. For either setting of D16_31, the 16 LSBs of external address (D_ADD[16:31]) are driven onto the selected 16 D_ADD_DAT pins. If additional address lines are required to interface to the memory, then non-muxed address pins are sometimes (see note below) required to complete the address space (e.g. D_ADD[8:15] are commonly present as non-muxed address pins).

NOTE

The EBI also drives the unused 16 D_ADD_DAT signals with the MSBs of the external address, zero-padded in front (e.g. when D16_31 bit is set for a device with 24 D_ADD pins, the EBI drives (0b00000000, D_ADD[8:15]) on D_ADD_DAT[0:15]. This allows the device to optionally use D_ADD_DAT[8:15] for the upper 8 external address lines instead of requiring separate non-muxed D_ADD[8:15] pins. This is relevant primarily for devices that support both 32-bit and 16-bit A/D muxed operation, so therefore have D_ADD_DAT[0:31] pins present on the device, and in that case are not required to have separate D_ADD pins.

For more details (e.g. timing diagrams), see [Section 30.4.2.12, Address Data Multiplexing](#).

The Address Latch Enable (ALE) indicates when the address is present during a multiplexed bus access using a D_ADD_DAT signal. This can be used in conjunction with an external latch to hold the state of the address access if connecting the MCU to a non-multiplexed bus compatible memory. ALE signal timing is shown in [Figure 30-1](#).

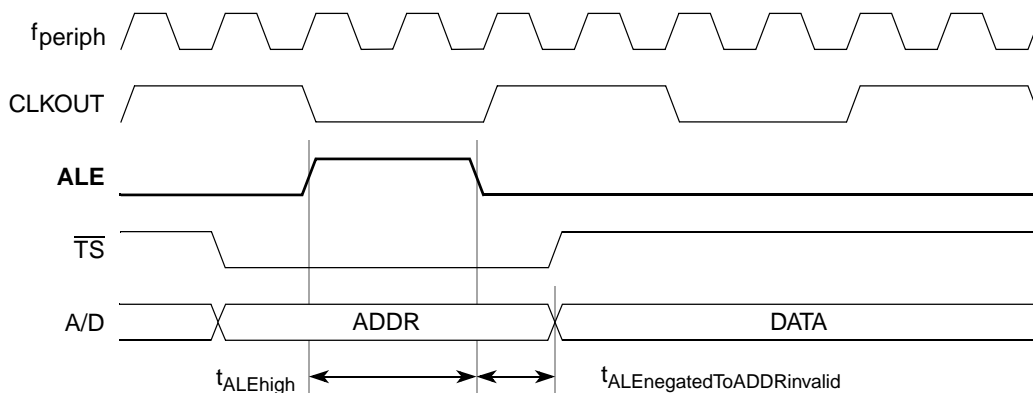

Figure 30-1. ALE signal timing

There are at least two timing requirements that relate to external components for multiplexed addr/data bus in systems using ALE. These are not EBI specs. The two are

- ALE - minimum high time
- ALE negated to ADDR invalid

These values depend on maximum clkout frequency and the actual clock tree insertion on the ALE clock gate.

Typical values should be calculated (and specified) as:

$$t_{ALEhigh} = f(\text{Clkout}) / 2 - 1nS \text{ (rise/fall uncertainty)}$$

$$t_{ALEtoADDRInvalid} = 1-3nS \text{ (depending on specified external part).}$$

30.1.4.7 Debug Mode

When the MCU is in Debug Mode, the EBI behavior is unaffected and remains dictated by the mode of the EBI.

30.2 External Signal Description

30.2.1 Overview

Table 30-2 lists the external pins used by the EBI. Not all signals listed here are available external to the chip. Refer to Table 30-1 and the Signals chapter for device-specific signal naming and availability.

Table 30-2. Signal Properties

| Name | I/O Type | Function | Pull ¹ |
|---------------------------|----------|----------------------------|-------------------|
| D_ADD[9:30] | I/O | Address bus | - |
| $\overline{D_BDIP}$ | Output | Burst Data in Progress | Up |
| D_CLKOUT ² | Output | Clockout | - |
| $\overline{CAL_CS}[0:3]$ | Output | Calibration Chip Selects | Up |
| D_ADD_DAT[0:31] | I/O | Data bus ³ | - |
| $\overline{D_OE}$ | Output | Output Enable | Up |
| D_RD_WR | I/O | Read_Write | Up |
| $\overline{D_TA}$ | I/O | Transfer Acknowledge | Up |
| $\overline{D_TEA}$ | I/O | Transfer Error Acknowledge | Up |
| $\overline{D_TS}$ | I/O | Transfer Start | Up |
| $\overline{D_WE}[0:3]$ | Output | Write/Byte Enables | Up |

¹ This column shows which signals require a weak pullup or pulldown. The EBI block does not contain these pullup/pulldown devices within the block. They are assumed to be in another module of the MCU (e.g. pads module).

² The D_CLKOUT signal is driven by the System Clock Block outside the EBI.

³ In Address/Data multiplexing modes, Data will also show the address during the address phase.

30.2.2 Address/Data Bus Configurations

Table 30-3 shows the function of the external pins in each of the possible muxed/non-muxed usage configurations allowed for this device.

Table 30-3. Function of EBI Pins for All Possible Configurations

| Mode | $\overline{D_WE}[0:3]$ | D_ADD[9:15] | D_ADD[16:30] ¹ D_ADD_DAT[16:30] ² | D_ADD_DAT [0:15] | D_CS2 ³ |
|---------------------------------------|-------------------------|--------------|--|---------------------------|----------------------|
| Non-muxed 16-bit mode | write/byte enable [0:1] | Address 9:15 | Address 16:30 | Data 0:15 | Address 31 |
| Muxed 32-bit mode | write/byte enable [0:3] | Not used | Address 16:30 / Data 16:30 | Address 0:15 / Data 0:15 | Address 31 / Data 31 |
| Muxed 16-bit mode (EBI_MCR[D16_31]=1) | write/byte enable [0:1] | Address 9:15 | Address 16:30 / Data 0:14 | Not used | Address 31 / Data 15 |
| Muxed 16-bit mode (EBI_MCR[D16_31]=0) | write/byte enable [0:1] | Address 9:15 | Not used | Address 16:31 / Data 0:15 | Not used |

¹ D_ADD[16:30] SIU PCR functionality must be selected in non-multiplexed mode (AD_MUX = 0)

² D_ADD_DAT[16:30] SIU PCR functionality must be selected in multiplexed mode (AD_MUX = 1)

³ D_CS2 is the primary function. Secondary function is EBI data only in non-mux mode and address/data in mux mode.

30.2.3 Detailed Signal Descriptions

30.2.3.1 D_ADD [9:30] — Address Lines 9-30

The D_ADD[9:30] signals specify the physical address of the bus transaction.

The 22 address lines correspond to bits 3-31 of the EBI's 32-bit internal address bus.

30.2.3.2 $\overline{D_BDIP}$ — Burst Data in Progress

$\overline{D_BDIP}$ is asserted to indicate that the master is requesting another data beat following the current one.

This signal is driven by the EBI on all EBI-mastered external burst cycles, but is only sampled by burst mode memories that have a corresponding pin. See [Section 30.4.2.5, Burst Transfer](#).

30.2.3.3 D_CLKOUT — Clockout

D_CLKOUT is a general-purpose clock output signal to connect to the clock input of SDR external memories and in some cases to the input clock of another MCU in multi-master configurations.

30.2.3.4 $\overline{CAL_CS}$ [0:3] — Calibration Chip Selects 0-3

$\overline{CAL_CS}_x$ is asserted by the master to indicate that this transaction is targeted for a particular memory bank on the Calibration external bus.

The calibration chip selects are driven only by the EBI. External master accesses on the Calibration bus are not supported. In all other aspects, the calibration chip-selects behave exactly as the primary chip-selects. See [Section 30.4.1.4, Memory Controller with Support for Various Memory Types](#) for details on chip-select operation.

30.2.3.5 D_ADD_DAT [0:31] — Data Lines 0-31

The D_ADD_DAT[0:31] signals contain the data to be transferred for the current transaction.

D_ADD_DAT[0:31] is driven by the EBI when it owns the external bus and it initiates a write transaction to an external device.

D_ADD_DAT[0:31] is driven by an external device during a read transaction from the EBI.

For 8-bit and 16-bit transactions, the byte lanes not selected for the transfer do not supply valid data.

D_ADD_DAT[0:31] is driven by the EBI in the address phase with the D_ADD value if the Address on Data multiplexing mode is enabled. See [Section 30.1.4.6, Multiplexed Address on Data Bus Mode](#), for details.

In 16-bit Data Bus Mode, (or for chip-select accesses to a 16-bit port), only D_ADD_DAT[0:15] or D_ADD_DAT[16:31] are used by the EBI, depending on the setting of the D16_31 bit in the EBI_MCR. See [Section 30.1.4.5, 16-Bit Data Bus Mode](#).

30.2.3.6 $\overline{D_OE}$ — Output Enable

$\overline{D_OE}$ is used to indicate when an external memory is permitted to drive back read data. External memories must have their data output buffers off when $\overline{D_OE}$ is negated. $\overline{D_OE}$ is only asserted for chip-select accesses.

For read cycles, $\overline{D_OE}$ is asserted one clock after $\overline{D_TS}$ assertion and held until the termination of the transfer. For write cycles, $\overline{D_OE}$ is negated throughout the cycle.

30.2.3.7 D_RD_ \overline{WR} — Read / Write

D_RD_ \overline{WR} indicates whether the current transaction is a read access or a write access.

D_RD_ \overline{WR} is driven in the same clock as the assertion of $\overline{D_TS}$ and valid address, and is kept valid until the cycle is terminated.

30.2.3.8 $\overline{D_TA}$ — Transfer Acknowledge

$\overline{D_TA}$ is asserted to indicate that the slave has received the data (and completed the access) for a write cycle, or returned data for a read cycle. If the transaction is a burst read, $\overline{D_TA}$ is asserted for each one of the transaction beats. For write transactions, $\overline{D_TA}$ is only asserted once at access completion, even if more than one write data beat is transferred.

$\overline{D_TA}$ is driven by the EBI when the access is controlled by the chip selects (and SETA=0). Otherwise, $\overline{D_TA}$ is driven by the slave device to which the current transaction was addressed.

See [Section 30.4.2.8, Termination Signals Protocol](#) for more details.

30.2.3.9 $\overline{D_TEA}$ — Transfer Error Acknowledge

$\overline{D_TEA}$ is asserted by either the EBI or an external device to indicate that an error condition has occurred during the bus cycle.

$\overline{D_TEA}$ is asserted by the EBI when the internal bus monitor detected a timeout error.

See [Section 30.4.2.8, Termination Signals Protocol](#) for more details.

30.2.3.10 $\overline{D_TS}$ — Transfer Start

$\overline{D_TS}$ is asserted by the current bus owner to indicate the start of a transaction on the external bus.

$\overline{D_TS}$ is only asserted for the first clock cycle of the transaction, and is negated in the successive clock cycles until the end of the transaction.

30.2.3.11 $\overline{D_WE}$ [0:3] — Write/Byte Enables 0-3

Write enables are used to enable program operations to a particular memory. These signals can also be used as byte enables for read and write operation by setting the WEBS bit in the appropriate Base Register. $\overline{D_WE}$ [0:3] are only asserted for chip-select accesses.

For chip-select accesses to a 16-bit port, only $\overline{D_WE}$ [0:1] are used by the EBI, regardless of which half of the D_ADD_DAT bus is selected via the $D16_31$ bit in the EBI_MCR .

See [Section 30.4.1.11, Four Write/Byte Enable \(\$\overline{D_WE}\$ \) Signals](#) for more details on $\overline{D_WE}$ [0:3] functionality.

30.2.4 Signal Output Buffer Enable Logic by Mode

[Table 30-4](#) describes how the EBI drives its output buffer enable (OBE) signals. These are internal signals from the EBI to device logic outside the EBI, that determine when the EBI strongly drives values on pins. When the OBE for an EBI signal is asserted (1), the EBI strongly drives the value on that pin. When the OBE is negated (0), the EBI does not drive the signal, and the value is determined by internal or external pullups/pulldowns, and/or device logic outside EBI block.

Table 30-4. Signal Output Buffer Enable Logic by Mode¹

| Signal | OBE Value by Mode (1=strongly driven, 0=not driven by EBI) | |
|-----------------------|--|--|
| | Module Disable Mode ² (MDIS=1) | Single Master Mode (MDIS=0) |
| D_ADD[9:30] | 0 | 1 |
| D_BDIP | 0 | 1 |
| CAL_CS[0:3] | 0 | 1 |
| D_ADD_DAT[0:31] | 0 | Only 1 during write access or on Address phase when Addr/Data muxing is enabled. |
| $\overline{D_OE}$ | 0 | 1 |
| D_RD_ \overline{WR} | 0 | 1 |

Table 30-4. Signal Output Buffer Enable Logic by Mode¹ (continued)

| Signal | OBE Value by Mode (1=strongly driven, 0=not driven by EBI) | |
|-------------------------|--|--|
| | Module Disable Mode ² (MDIS=1) | Single Master Mode (MDIS=0) |
| $\overline{D_TA}$ | 0 | Only 1 during chip-select (or cal-chip-select) SETA=0 access |
| $\overline{D_TEA}$ | 0 | Only 1 for 2 cycles when timeout occurs |
| $\overline{D_TS}$ | 0 | 1 |
| $\overline{D_WE}[0:3]$ | 0 | 1 |

¹ The values in this table only indicate when signals are strongly driven, not the logic value on the pin itself.

² This assumes that the clock to the EBI is shut off when MDIS=1. This is an optional device feature. If the clocks are left running to EBI even when MDIS=1, then the EBI OBE behavior is as if in Single Master Mode (though EBI accesses are not supported in this scenario).

30.3 Memory Map/Register Definition

Table 30-5 shows the EBI registers.

Table 30-5. EBI Address Map

| Address | Register | Bits | Access | Reset Value | Section/Page |
|----------------------------------|--|------|--------|-------------|--------------------------------|
| EBI_BASE | EBI_MCR—EBI Module Configuration Register | 32 | R/W | 0x0000_0000 | 30.3.1.1/30-10 |
| EBI_BASE+0x4 | Reserved | | | | |
| EBI_BASE+0x8 | EBI_TESR—EBI Transfer Error Status Register | 32 | R | 0x0000_0000 | 30.3.1.2/30-11 |
| EBI_BASE+0xC | EBI_BMCR—EBI Bus Monitor Control Register | 32 | R/W | 0x0000_FF80 | 30.3.1.3/30-12 |
| EBI_BASE+0x10 – EBI_BASE+0x3C | Reserved | | | | |
| EBI_BASE+0x40 | EBI_CAL_BR0—EBI Calibration Base Register Bank 0 | 32 | R/W | 0x2000_0002 | 30.3.1.4/30-13 |
| EBI_BASE+0x44 | EBI_CAL_OR0—EBI Calibration Option Register Bank 0 | 32 | R/W | 0xE000_0000 | 30.3.1.5/30-15 |
| EBI_BASE+0x48 | EBI_CAL_BR1—EBI Calibration Base Register Bank 1 | 32 | R/W | 0x2000_0002 | 30.3.1.4/30-13 |
| EBI_BASE+0x4C | EBI_CAL_OR1—EBI Calibration Option Register Bank 1 | 32 | R/W | 0xE000_0000 | 30.3.1.5/30-15 |
| EBI_BASE+0x50 | EBI_CAL_BR2—EBI Calibration Base Register Bank 2 | 32 | R/W | 0x2000_0002 | 30.3.1.4/30-13 |
| EBI_BASE+0x54 | EBI_CAL_OR2—EBI Calibration Option Register Bank 2 | 32 | R/W | 0xE000_0000 | 30.3.1.5/30-15 |
| EBI_BASE+0x58 | EBI_CAL_BR3—EBI Calibration Base Register Bank 3 | 32 | R/W | 0x2000_0002 | 30.3.1.4/30-13 |
| EBI_BASE+0x5C | EBI_CAL_OR3—EBI Calibration Option Register Bank 3 | 32 | R/W | 0xE000_0000 | 30.3.1.5/30-15 |

30.3.1 Register Descriptions

NOTE

Other than the bits in the TESR register, EBI registers must not be written while a transaction to the EBI (from internal master) is in progress (or within 2 D_CLKOUT cycles after a transaction has just completed, to allow internal state machines to go IDLE). In those cases, the behavior is undefined.

See [Section 30.5.1, Booting from External Memory](#) for related application information.

30.3.1.1 EBI Module Configuration Register (EBI_MCR)

Offset: EBI_BASE+0 Access: User read/write

| | | | | | | | | | | | | | | | | |
|--------|---|---|---|---|---|---|---|---|---|---|----|----|----|----|----|----|
| | 0 | 1 | 2 | 3 | 4 | 5 | 6 | 7 | 8 | 9 | 10 | 11 | 12 | 13 | 14 | 15 |
| R | 0 | 0 | 0 | 0 | 0 | 0 | 0 | 0 | 0 | 0 | 0 | 0 | 0 | 0 | 0 | 0 |
| W | | | | | | | | | | | | | | | | |
| RESET: | 0 | 0 | 0 | 0 | 0 | 0 | 0 | 0 | 0 | 0 | 0 | 0 | 0 | 0 | 0 | 0 |

| | | | | | | | | | | | | | | | | |
|--------|------|----|----|----|----|----|----|----|----|------|----|----|----|--------|--------|-----|
| | 16 | 17 | 18 | 19 | 20 | 21 | 22 | 23 | 24 | 25 | 26 | 27 | 28 | 29 | 30 | 31 |
| R | ACGE | 0 | 0 | 0 | 1 | 0 | 0 | 0 | 0 | MDIS | 0 | 0 | 0 | D16_31 | AD_MUX | DBM |
| W | | | | | | | | | | | | | | | | |
| RESET: | 0 | 0 | 0 | 0 | 1 | 0 | 0 | 0 | 0 | 0 | 0 | 0 | 0 | 0 | 0 | 0 |

Figure 30-2. EBI Module Configuration Register (EBI_MCR)

The EBI Module Configuration Register contains bits which configure various attributes associated with EBI operation.

Table 30-6. EBI_MCR Field Descriptions

| Field | Description |
|------------|---|
| 0-15 | Reserved |
| 16 ACGE | Automatic D_CLKOUT Gating Enable The ACGE bit enables the EBI feature of turning off D_CLKOUT (holding it high) during idle periods in-between external bus accesses. 0 Automatic D_CLKOUT Gating is disabled 1 Automatic D_CLKOUT Gating is enabled |
| 17-24 | Reserved |

Table 30-6. EBI_MCR Field Descriptions (continued)

| Field | Description |
|--------------|--|
| 25 MDIS | Module Disable Mode The MDIS bit controls an internal EBI "enable clk" signal which can be used (if MCU logic supports) to control the clocks to the EBI. The MDIS bit allows the clock to be stopped to the non-memory mapped logic in the EBI, effectively putting the EBI in a software controlled power-saving state. See Section 29.1.4.3, "Module Disable Mode for more information. No external bus accesses can be performed when the EBI is in Module Disable Mode (MDIS=1). 0 Module Disable Mode is inactive (assert "enable clk" signal) 1 Module Disable Mode is active (negate "enable clk" signal) |
| 26-28 | Reserved |
| 29 D16_31 | Data Bus 16_31 Select The D16_31 bit controls whether the EBI uses the D_ADD_DAT[0:15] or D_ADD_DAT[16:31] signals, when in 16-bit Data Bus Mode (DBM=1) or for chip-select accesses to a 16-bit port (PS=1). For systems using A/D muxing with a 16-bit port, it is recommended to set D16_31 to 1. 0 D_ADD_DAT[0:15] signals are used for 16-bit port accesses 1 D_ADD_DAT[16:31] signals are used for 16-bit port accesses |
| 30 AD_MUX | Address on Data Bus Multiplexing Mode The AD_MUX bit controls whether non-chip-select accesses have the address driven on the data bus in the address phase of a cycle. 0 Only Data on data pins for non-CS accesses. 1 Address on Data Multiplexing Mode is used for non-CS accesses. |
| 31 DBM | Data Bus Mode The DBM bit controls whether the EBI is in 32-bit or 16-bit Data Bus Mode. 0 32-bit Data Bus Mode is used 1 16-bit Data Bus Mode is used |

30.3.1.2 EBI Transfer Error Status Register (EBI_TESR)

Offset: EBI_BASE+0x8 Access: User read

| | 0 | 1 | 2 | 3 | 4 | 5 | 6 | 7 | 8 | 9 | 10 | 11 | 12 | 13 | 14 | 15 |
|--------|---|---|---|---|---|---|---|---|---|---|----|----|----|----|----|----|
| R | 0 | 0 | 0 | 0 | 0 | 0 | 0 | 0 | 0 | 0 | 0 | 0 | 0 | 0 | 0 | 0 |
| W | | | | | | | | | | | | | | | | |
| RESET: | 0 | 0 | 0 | 0 | 0 | 0 | 0 | 0 | 0 | 0 | 0 | 0 | 0 | 0 | 0 | 0 |

| | 16 | 17 | 18 | 19 | 20 | 21 | 22 | 23 | 24 | 25 | 26 | 27 | 28 | 29 | 30 | 31 |
|--------|----|----|----|----|----|----|----|----|----|----|----|----|----|----|------|------|
| R | 0 | 0 | 0 | 0 | 0 | 0 | 0 | 0 | 0 | 0 | 0 | 0 | 0 | 0 | TEAF | BMTF |
| W | | | | | | | | | | | | | | | | |
| RESET: | 0 | 0 | 0 | 0 | 0 | 0 | 0 | 0 | 0 | 0 | 0 | 0 | 0 | 0 | 0 | 0 |

Figure 30-3. EBI Transfer Error Status Register (EBI_TESR)

The EBI Transfer Error Status Register contains a bit for each type of transfer error on the external bus. A bit set to logic 1 indicates what type of transfer error occurred since the last time the bits were cleared. Each bit can be cleared by reset or by writing a 1 to it. Writing a 0 has no effect. This register cannot be written when the MDIS bit is set in the EBI_MCR.

Table 30-7. EBI_TESR Field Descriptions

| Field | Description |
|------------|--|
| 0-29 | Reserved |
| 30 TEAF | Transfer Error Acknowledge Flag This bit is set if the cycle was terminated by an externally generated $\overline{D_TEA}$ signal. 0 No error 1 External $\overline{D_TEA}$ occurred |
| 31 BMTF | Bus Monitor Timeout Flag This bit is set if the cycle was terminated by a bus monitor timeout. 0 No error 1 Bus monitor timeout occurred |

30.3.1.3 EBI Bus Monitor Control Register (EBI_BMCR)

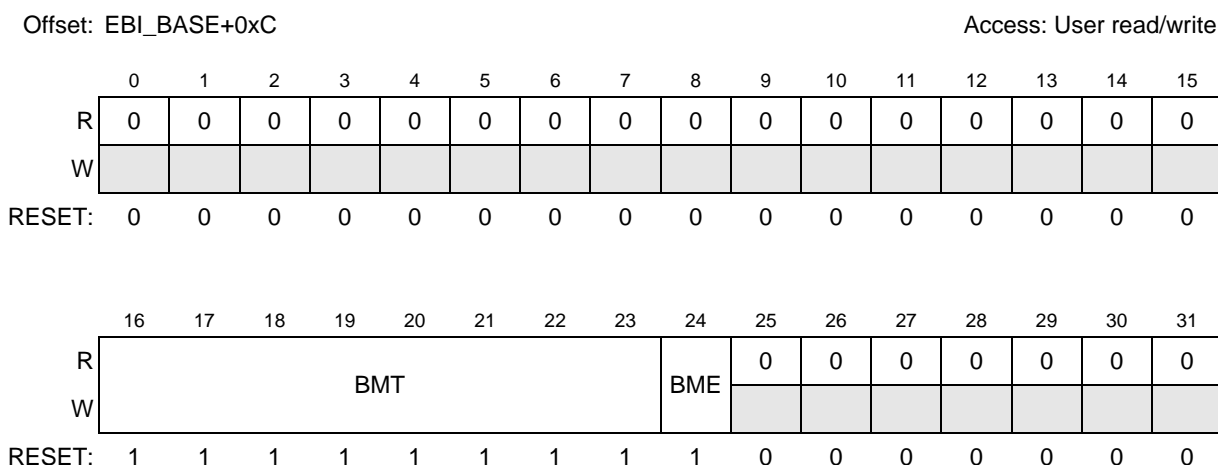

Figure 30-4. EBI Bus Monitor Control Register (EBI_BMCR)

The EBI Bus Monitor Control Register controls the timeout period of the bus monitor and whether it is enabled or disabled.

Table 30-8. EBI_BMCR Descriptions

| Field | Description |
|--------------|--|
| 0-15 | Reserved |
| 16–23 BMT | Bus Monitor Timing This field defines the timeout period, in 8 external bus clock resolution, for the Bus Monitor. See Section 30.4.1.6, Bus Monitor , for more details on bus monitor operation. Timeout Period = $(2 + (8 * BMT)) / \text{external bus clock frequency}$. |

Table 30-8. EBI_BMCR Descriptions (continued)

| Field | Description |
|-----------|--|
| 24 BME | Bus Monitor Enable This bit controls whether the bus monitor is enabled for internal to external bus cycles. The BME bit is ignored (treated as 0) for chip-select accesses with internal $\overline{D_TA}$ (SETA=0). 0 Disable bus monitor 1 Enable bus monitor (for external $\overline{D_TA}$ accesses only) |
| 25–31 | Reserved |

30.3.1.4 EBI Base Registers (EBI_CAL_BR0-3)

Offset: $\text{EBI_BASE} + 0x40, 0x48, 0x50, 0x58$ Access: User read/write

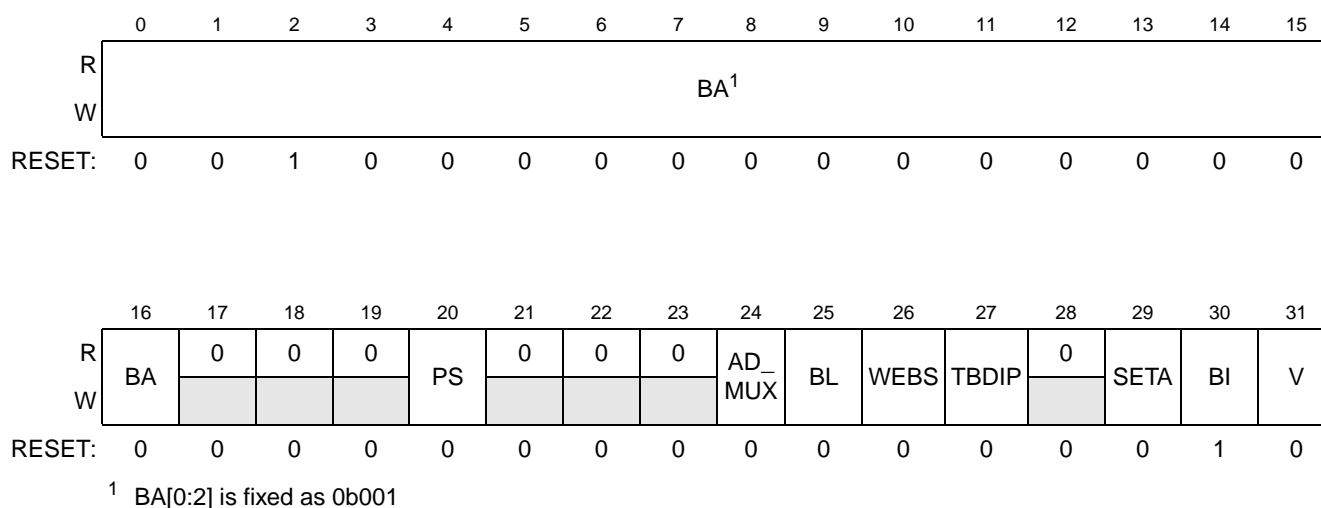
Figure 30-5. EBI Base Registers (EBI_CAL_BR0-3)

The EBI Base Registers are used to define the base address and other attributes for the corresponding chip select.

Table 30-9. EBI_CAL_BR0-3 Descriptions

| Field | Description |
|------------|--|
| 0-16 BA | Base Address These bits are compared to the corresponding unmasked address signals among D_ADD[0:16] of the internal address bus to determine if a memory bank controlled by the memory controller is being accessed by an internal bus master. |
| 17–19 | Reserved |

Table 30-9. EBI_CAL_BR0-3 Descriptions (continued)

| Field | Description | | | | | | | | | | | | | | | | |
|----------------|--|------------|-------------------------------|----|-------------------------------|----------------|---------------------|------------|---|------------|----|---|--------|------------|---|------------|---|
| 20 PS | <p>Port Size</p> <p>The PS bit determines the data bus width of transactions to this chip-select bank.</p> <p>Note: In the case where the DBM bit in EBI_MCR is set for 16-bit Data Bus Mode, the PS bit value is ignored and is always treated as a '1' (16-bit port).</p> <p>0 32-bit port 1 16-bit port</p> | | | | | | | | | | | | | | | | |
| 21–23 | Reserved | | | | | | | | | | | | | | | | |
| 24 AD_MUX | <p>Address on Data Bus Multiplexing</p> <p>The AD_MUX bit controls whether accesses for this chip select have the address driven on the data bus in the address phase of a cycle.</p> <p>0 Address on Data Multiplexing Mode is disabled for this chip select. 1 Address on Data Multiplexing Mode is enabled for this chip select.</p> | | | | | | | | | | | | | | | | |
| 25 BL | <p>Burst Length</p> <p>The BL bit determines the amount of data transferred in a burst for this chip select, measured in 32-bit words. The number of beats in a burst is automatically determined by the EBI to be 4, 8, or 16 according to the Port Size (PS bit) so that the burst fetches the number of words chosen by BL (see Table 29-10). For internal AMBA data bus width of 32-bits, the BL bit is ignored (treated as 1).</p> <table border="1" style="margin-left: auto; margin-right: auto;"> <thead> <tr> <th>Value</th> <th>Burst Length¹</th> <th>PS</th> <th># Beats in Burst²</th> </tr> </thead> <tbody> <tr> <td rowspan="2">0³</td> <td rowspan="2">8-word⁴</td> <td>0 (32-bit)</td> <td>8</td> </tr> <tr> <td>1 (16-bit)</td> <td>16</td> </tr> <tr> <td rowspan="2">1</td> <td rowspan="2">4-word</td> <td>0 (32-bit)</td> <td>4</td> </tr> <tr> <td>1 (16-bit)</td> <td>8</td> </tr> </tbody> </table> <p>¹ Total amount of data fetched in a burst transfer. ² Number of external data beats used in external burst transfer. The size of each beat is determined by PS value. ³ An 8-word burst length is only supported for device's using 64-bit AMBA data bus width to EBI. ⁴ A word always refers to 32-bits of data, regardless of PS.</p> <p>Note: The EBI does NOT support a 2-word external burst length. This means that neither a 4-beat burst to a 16-bit external memory (nor a 2-beat burst to 32-bit external memory) are supported.</p> | Value | Burst Length ¹ | PS | # Beats in Burst ² | 0 ³ | 8-word ⁴ | 0 (32-bit) | 8 | 1 (16-bit) | 16 | 1 | 4-word | 0 (32-bit) | 4 | 1 (16-bit) | 8 |
| Value | Burst Length ¹ | PS | # Beats in Burst ² | | | | | | | | | | | | | | |
| 0 ³ | 8-word ⁴ | 0 (32-bit) | 8 | | | | | | | | | | | | | | |
| | | 1 (16-bit) | 16 | | | | | | | | | | | | | | |
| 1 | 4-word | 0 (32-bit) | 4 | | | | | | | | | | | | | | |
| | | 1 (16-bit) | 8 | | | | | | | | | | | | | | |
| 26 WEBS | <p>Write Enable / Byte Select</p> <p>This bit controls the functionality of the $\overline{D_WE}[0:3]$ signals.</p> <p>0 The $\overline{D_WE}[0:3]$ signals function as $\overline{WE}[0:3]$ 1 The $\overline{D_WE}[0:3]$ signals function as $\overline{BE}[0:3]$</p> | | | | | | | | | | | | | | | | |
| 27 TBDIP | <p>Toggle Burst Data in Progress</p> <p>This bit determines how long the D_BDIP signal is asserted for each data beat in a burst cycle. See Section 30.4.2.5.1, TBDIP Effect on Burst Transfer, for details.</p> <p>0 Assert $\overline{D_BDIP}$ throughout the burst cycle, regardless of wait state configuration. 1 Only assert $\overline{D_BDIP}$ (BSCY+1) external cycles before expecting subsequent burst data beats.</p> | | | | | | | | | | | | | | | | |
| 28 | Reserved | | | | | | | | | | | | | | | | |

Table 30-9. EBI_CAL_BR0-3 Descriptions (continued)

| Field | Description |
|------------|---|
| 29 SETA | Select External Transfer Acknowledge The SETA bit controls whether accesses for this chip select will terminate (end transfer without error) based on externally asserted $\overline{D_TA}$ or internally asserted $\overline{D_TA}$. SETA should only be set when the BI bit is 1 as well, since burst accesses with SETA=1 are not supported. Setting SETA=1 causes the BI bit to be ignored (treated as 1, burst inhibited). 0 Transfer Acknowledge ($\overline{D_TA}$) is an output from the EBI, data phase will be terminated by the EBI. 1 Transfer Acknowledge ($\overline{D_TA}$) is an input to the EBI, data phase will be terminated by an external device. |
| 30 BI | Burst Inhibit This bit determines whether or not burst read accesses are allowed for this chip-select bank. The BI bit is ignored (treated as 1) for chip-select accesses with external $\overline{D_TA}$ (SETA=1). 0 Enable burst accesses for this bank. 1 Disable burst accesses for this bank. This is the default value out of reset (or when SETA=1). |
| 31 V | Valid bit The user writes this bit to indicate that the contents of this Base Register and Option Register pair are valid. The appropriate \overline{CS} signal does not assert unless the corresponding V-bit is set. 0 This bank is not valid. 1 This bank is valid. |

30.3.1.5 EBI Option Registers (EBI_CAL_OR0-3)

Offset: EBI_BASE+0x44, 0x4C, 0x54, 0x5C

Access: User read/write

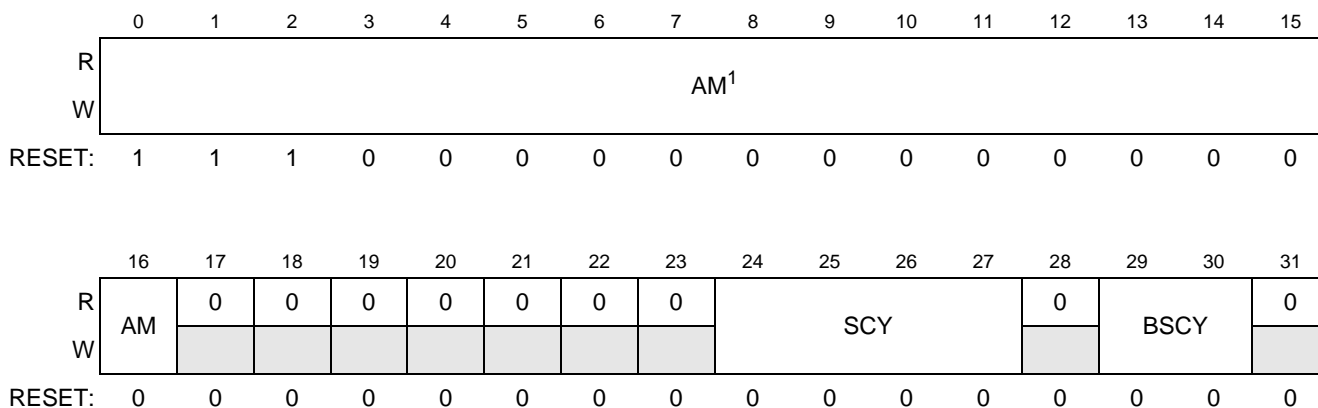

¹ AM[0:2] is set to a fixed value of 0b111.

Figure 30-6. EBI Option Registers (EBI_CAL_OR0-3)

The EBI Option Registers are used to define the address mask and other attributes for the corresponding chip select.

Table 30-10. EBI_CAL_OR0-3 Descriptions

| Field | Description | | | | | | | | | | |
|---------------|---|-------|---------|----|---|----|--|----|--|----|--|
| 0-16 AM | <p>Address Mask</p> <p>This field allows masking of any corresponding bits in the associated Base Register. Masking the address independently allows external devices of different size address ranges to be used. Any clear bit masks the corresponding address bit. Any set bit causes the corresponding address bit to be used in comparison with the address pins. Address mask bits can be set or cleared in any order in the field, allowing a resource to reside in more than one area of the address map. This field can be read or written at any time.</p> <p>Note: An MCU may have some of the upper bits of the AM field tied to a fixed value internally in order to restrict the address range of the EBI for that MCU. See the corresponding Note for the Base Register BA field for more details.</p> | | | | | | | | | | |
| 17-23 | Reserved | | | | | | | | | | |
| 24-27 SCY | <p>Cycle length in clocks</p> <p>This field represents the number of wait states (external cycles) inserted after the address phase in the single transfer case, or in the first beat of a burst, when the memory controller handles the external memory access. Values range from 0 to 15. This is the main parameter for determining the length of the cycle. These bits are ignored when SETA=1.</p> <p>The total cycle length for the first beat (including the D_TS cycle) = (2+SCY) external clock cycles. See Section Section 30.5.3.1, Example Wait State Calculation, for related application information.</p> | | | | | | | | | | |
| 28 | Reserved | | | | | | | | | | |
| 29-30 BSCY | <p>Burst beats length in clocks</p> <p>This field determines the number of wait states (external cycles) inserted in all burst beats except the first, when the memory controller starts handling the external memory access and thus is using SCY[0:3] to determine the length of the first beat. These bits are ignored when SETA=1.</p> <p>The total memory access length for each beat is (1 + BSCY) external clock cycles. The total cycle length (including the D_TS cycle) = (2+SCY) + (#beats¹-1) * (BSCY+1).</p> <table border="1" style="margin-left: auto; margin-right: auto;"> <thead> <tr> <th>Value</th> <th>Meaning</th> </tr> </thead> <tbody> <tr> <td>00</td> <td>0-clock cycle wait states (1 clock per data beat)</td> </tr> <tr> <td>01</td> <td>1-clock cycle wait states (2 clocks per data beat)</td> </tr> <tr> <td>10</td> <td>2-clock cycle wait states (3 clocks per data beat)</td> </tr> <tr> <td>11</td> <td>3-clock cycle wait states (4 clocks per data beat)</td> </tr> </tbody> </table> | Value | Meaning | 00 | 0-clock cycle wait states (1 clock per data beat) | 01 | 1-clock cycle wait states (2 clocks per data beat) | 10 | 2-clock cycle wait states (3 clocks per data beat) | 11 | 3-clock cycle wait states (4 clocks per data beat) |
| Value | Meaning | | | | | | | | | | |
| 00 | 0-clock cycle wait states (1 clock per data beat) | | | | | | | | | | |
| 01 | 1-clock cycle wait states (2 clocks per data beat) | | | | | | | | | | |
| 10 | 2-clock cycle wait states (3 clocks per data beat) | | | | | | | | | | |
| 11 | 3-clock cycle wait states (4 clocks per data beat) | | | | | | | | | | |
| 31 | Reserved | | | | | | | | | | |

¹ #beats is the number of beats (4,8,16) determined by BL and PS bits in Base Register.

30.4 Functional Description

30.4.1 External Bus Interface Features

30.4.1.1 Address Bus (up to 22 available on pins)

. Valid transaction sizes are 8, 16 and 32 bits. Only 22 address lines are pinned out externally, but a full 32-bit decode is done internally to determine the target of the transaction and whether a chip select should be asserted.

30.4.1.2 32-Bit Data Bus (16-bit Data Bus Mode also supported)

The entire 32-bit data bus is available (through muxing) for external memory accesses. There is also a 16-bit Data Bus Mode available via the DBM bit in EBI_MCR. See [Section 30.1.4.5, 16-Bit Data Bus Mode](#).

30.4.1.3 Multiplexed Address on Data Pins (internal master only)

When this mode is enabled, the address shows up on the data pins during the address phase of the cycle. This mode can be enabled separately for non-chip-select accesses and per chip-select access. See [Section 30.1.4.6, Multiplexed Address on Data Bus Mode](#).

30.4.1.4 Memory Controller with Support for Various Memory Types

The EBI contains a memory controller that supports a variety of memory types, including synchronous burst mode flash and SRAM, and asynchronous/legacy flash and SRAM with a compatible interface.

Each \overline{CS} bank is configured via its own pair of Base and Option Registers. Each time an internal to external bus cycle access is requested, the internal address is compared with the base address of each valid Base Register (with 17 bits having mask). See [Figure 30-7](#). If a match is found, the attributes defined for this bank in its BR and OR are used to control the memory access. If a match is found in more than one bank, the lowest bank matched handles the memory access (e.g., bank 0 is selected over bank 1).

A match on a valid calibration chip-select register overrides a match on any non-calibration chip-select register, with CAL_CS0 having the highest priority. Thus the full priority of the chip-selects is: CAL_CS0, ..., CAL_CS3, CS0, ..., CS3

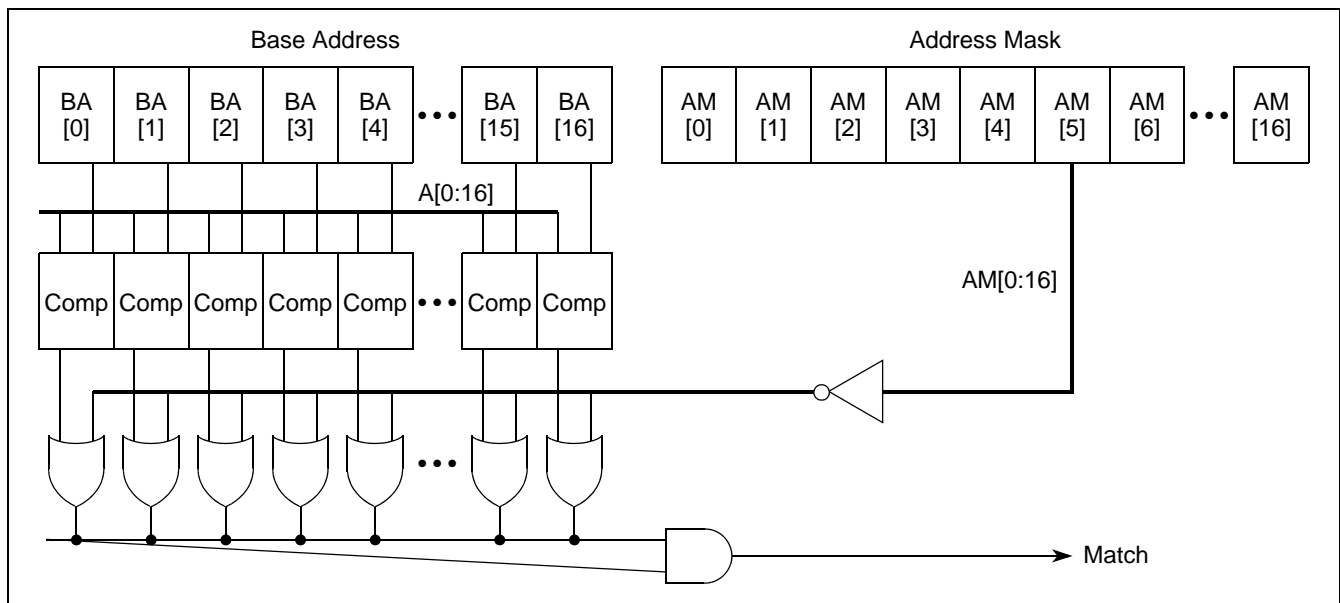

Figure 30-7. Bank Base Address & Match Structure

When a match is found on one of the chip-select banks, all its attributes (from the appropriate Base and Option Registers) are selected for the functional operation of the external memory access, such as:

External Bus Interface (EBI)

- Number of wait states for a single memory access, and for any beat in a burst access
- Burst enable
- Port size for the external accessed device

See [Section 30.3.1.4, EBI Base Registers \(EBI_CAL_BR0-3\)](#) and [Section 30.3.1.5, EBI Option Registers \(EBI_CAL_OR0-3\)](#) for a full description of all chip-select attributes.

When no match is found on any of the chip-select banks, the default transfer attributes shown in [Table 30-11](#) are used.

Table 30-11. Default Attributes for Non-Chip-Select Transfers

| CS Attribute | Default Value | Comment |
|--------------|---------------|---|
| PS | 0 | 32-bit port size |
| BL | 0 | burst length is don't care since burst is disabled |
| WEBS | 0 | write enables |
| TBDIP | 0 | don't care since burst is disabled |
| BI | 1 | burst inhibited |
| SCY | 0 | don't care since external $\overline{D_TA}$ is used |
| BSCY | 0 | don't care since external $\overline{D_TA}$ is used |
| AD_MUX | 0 | Address on Data multiplexing (depends on EBI_MCR[AD_MUX] value) |
| SETA | 1 | Select external $\overline{D_TA}$ to terminate access |

30.4.1.5 Burst Support (wrapped only)

The EBI supports burst read accesses of external burstable memory. To enable bursts to a particular memory region, clear the BI (Burst Inhibit) bit in the appropriate Base Register. External burst lengths of 4 and 8 words are supported. Burst length is configured for each chip select by using the BL bit in the appropriate Base Register. See [Section 30.4.2.5, Burst Transfer](#) for more details on burst operation.

In 16-bit data bus mode (DBM=1 in EBI_MCR), a special 2-beat burst case is supported for reads and writes for 32-bit non-chip-select accesses only. This is to allow 32-bit coherent accesses to another MCU. See [Section 30.4.2.9, Non-Chip-Select Burst in 16-bit Data Bus Mode](#).

Bursting of accesses that are not controlled by the chip selects is not supported for any other case besides the special case of 32-bit accesses in 16-bit data bus mode.

Burst writes are not supported for any other case besides the special case of 32-bit non-chip-select writes in 16-bit data bus mode. Internal requests to write >32 bits (such as a cache line) externally are broken up into separate 32-bit or 16-bit external transactions according to the port size. See [Section 30.4.2.6, Small Accesses \(Small Port Size and Short Burst Length\)](#) for more detail on these cases.

30.4.1.6 Bus Monitor

When enabled (via the BME bit in the EBI_BMCR), the bus monitor detects when no $\overline{D_TA}$ assertion is received within a maximum timeout period for external $\overline{D_TA}$ accesses. The timeout for the bus monitor is specified by the BMT field in the EBI_BMCR. Each time a timeout error occurs, the BMTF bit is set in the EBI_TESR. The timeout period is measured in external bus ($\overline{D_CLKOUT}$) cycles. Thus the effective

real-time period is multiplied (by 2, 3, etc.) when a slower-speed mode is used, even though the BMT field itself is unchanged.

30.4.1.7 Port Size Configuration per Chip Select (16 or 32 bits)

The EBI supports memories with data widths of 16 or 32 bits. The port size for a particular chip select is configured by writing the PS bit in the corresponding Base Register.

30.4.1.8 Configurable Wait States

From 0 to 15 wait states can be programmed for any cycle that the memory controller generates, via the SCY bits in the appropriate Option Register. From 0 to 3 wait states between burst beats can be programmed using the BSCY bits in the appropriate Option Register.

30.4.1.9 Configurable internal or external $\overline{D_TA}$ per chip select

Each chip select can be configured (via the SETA bit) to have $\overline{D_TA}$ driven internally (by the EBI), or externally (by an external device). See [Section 30.3.1.4, EBI Base Registers \(EBI_CAL_BR0-3\)](#), for more details on SETA bit usage.

30.4.1.10 Support for Dynamic Calibration with up to 4 chip-selects

The EBI contains 4 calibration chip select signals, controlling 4 independent memory banks on the external calibration bus. See [Section 30.4.2.10, Calibration Bus Operation](#), for more details on using the calibration bus.

30.4.1.11 Four Write/Byte Enable ($\overline{D_WE}$) Signals

The functionality of the $\overline{D_WE}[0:3]$ signals depends on the value of the WEBS bit in the corresponding Base Register. Setting WEBS to 1 configures these pins as $\overline{BE}[0:3]$, while resetting it to 0 configures them as $\overline{WE}[0:3]$. $\overline{WE}[0:3]$ are asserted only during write accesses, while $\overline{BE}[0:3]$ is asserted for both read and write accesses. The timing of the $\overline{D_WE}[0:3]$ signals remains the same in either case.

The upper Write/Byte Enable ($\overline{D_WE0}$) indicates that the upper eight bits of the data bus ($D_ADD_DAT[0:7]$) contain valid data during a write/read cycle. The upper middle Write/Byte Enable ($\overline{D_WE1}$) indicates that the upper middle eight bits of the data bus ($D_ADD_DAT[8:15]$) contain valid data during a write/read cycle. The lower middle Write/Byte Enable ($\overline{D_WE2}$) indicates that the lower middle eight bits of the data bus ($D_ADD_DAT[16:23]$) contain valid data during a write/read cycle. The lower Write/Byte Enable ($\overline{D_WE3}$) indicates that the lower eight bits of the data bus ($D_ADD_DAT[24:31]$) contain valid data during a write/read cycle.

NOTE

The exception to the preceding $\overline{D_WE}$ description is that for 16-bit port transfers (DBM=1 or PS=1), only the $\overline{D_WE}[0:1]$ signals are used, regardless of whether $D_ADD_DAT[0:15]$ or $D_ADD_DAT[16:31]$ are selected (via the D16_31 bit in the EBI_MCR). This means for the case where $D_ADD_DAT[16:31]$ are selected, that $\overline{WE0}$ indicates that $D_ADD_DAT[16:23]$ contains valid data, and $\overline{WE1}$ indicates that $D_ADD_DAT[24:31]$ contains valid data.

The Write/Byte Enable lines affected in a transaction for a 32-bit port (PS = 0) and a 16-bit port (PS=1) are shown in Table 30-12. Only Big Endian byte ordering is supported by the EBI.

Table 30-12. Write/Byte Enable Signals Function ¹

| Transfer Size | Address | | 32-Bit Port Size | | | | 16-Bit Port Size ² | | | |
|---------------|---------|-----|----------------------|----------------------|----------------------|----------------------|-------------------------------|----------------------|----------------------|----------------------|
| | A30 | A31 | $\overline{D_WE}_0$ | $\overline{D_WE}_1$ | $\overline{D_WE}_2$ | $\overline{D_WE}_3$ | $\overline{D_WE}_0$ | $\overline{D_WE}_1$ | $\overline{D_WE}_2$ | $\overline{D_WE}_3$ |
| Byte | 0 | 0 | X | | | | X | | | |
| | 0 | 1 | | X | | | | X | | |
| | 1 | 0 | | | X | | X | | | |
| | 1 | 1 | | | | X | | X | | |
| 16-bit | 0 | 0 | X | X | | | X | X | | |
| | 1 | 0 | | | X | X | X | X | | |
| 32-bit | 0 | 0 | X | X | X | X | X ³ | X ³ | | |
| Burst | 0 | 0 | X | X | X | X | X | X | | |

¹ This table applies to aligned internal master transfers only. In the case of a misaligned internal master transfer that is split into multiple aligned external transfers, not all of the write enables X'd in the table will necessarily assert. See Section 30.4.2.11, Misaligned Access Support.

² Also applies when DBM=1 for 16-bit data bus mode.

³ This case consists of two 16-bit external transactions, but for both transactions the $\overline{D_WE}[0:1]$ signals are the only $\overline{D_WE}$ signals affected.

30.4.1.12 Slower-Speed Clock Modes

For memories that cannot run with a full-speed external bus, the EBI supports slower-speed clock modes. Refer to Section 30.1.4.4, Slower-Speed Modes for more details on this feature. The timing diagrams for slower-speed modes are identical to those for full-speed mode, except that the frequency of D_CLKOUT is reduced.

30.4.1.13 Stop and Module Disable Modes for Power Savings

See Section 30.1.4, Modes of Operation for a description of the power saving modes.

30.4.1.14 Optional Automatic D_CLKOUT Gating

The EBI has the ability to hold the external D_CLKOUT pin high when the EBI's internal master state machine is idle and no requests are pending. The EBI outputs a signal to the pads logic in the MCU to disable D_CLKOUT. This feature is disabled out of reset, and can be enabled or disabled by the ACGE bit in the EBI_MCR.

NOTE

This feature must be disabled for multi-master systems. In those cases, one master is getting its clock source from the other master and needs it to stay valid continuously.

30.4.1.15 Misaligned Access Support

The EBI has limited misaligned access support. Misaligned non-burst chip-select transfers from internal masters are supported. The EBI aligns the accesses when it sends them out to the external bus (splitting them into multiple aligned accesses if necessary), so that external devices are not required to support misaligned accesses. Burst accesses (internal master) must match the internal bus size (64-bit aligned). See [Section 30.4.2.11, Misaligned Access Support](#), for more details.

30.4.1.16 Compatible with MPC5xx External Bus (with some limitations)

The EBI is compatible with the external bus of the MPC5xx parts, meaning that it supports most devices supported by the MPC5xx family of parts. However, there are some differences between this EBI and that of the MPC5xx parts that the user needs to be aware of before assuming that an MPC5xx-compatible device works with this EBI. See [Section 30.5.5, Summary of Differences from MPC5xx](#), for details.

NOTE

Due to testing and complexity concerns, multi-master (or master/slave) operation between an eSys MCU and MPC5xx is not guaranteed.

30.4.2 External Bus Operations

The following sections provide a functional description of the external bus, the bus cycles provided for data transfer operations, and error conditions.

30.4.2.1 External Clocking

Possible division factors for D_CLKOUT: 1, 2, and 4.

The D_CLKOUT signal sets the frequency of operation for the bus interface directly. Internally, the MCU uses a phase-locked loop (PLL) circuit to generate a master clock for all of the MCU circuitry (including the EBI) which is phase-locked to the D_CLKOUT signal. In general, all signals for the EBI are specified with respect to the rising-edge of the D_CLKOUT signal, and they are guaranteed to be sampled as inputs or changed as outputs with respect to that edge.

30.4.2.2 Reset

Upon detection of internal reset assertion, the EBI immediately ends all transactions (abruptly, not through normal termination protocol), and ignores any transaction requests that take place while reset is asserted.

30.4.2.3 Basic Transfer Protocol

The basic transfer protocol defines the sequence of actions that must occur on the external bus to perform a complete bus transaction. A simplified scheme of the basic transfer protocol is shown in [Figure 30-8](#).

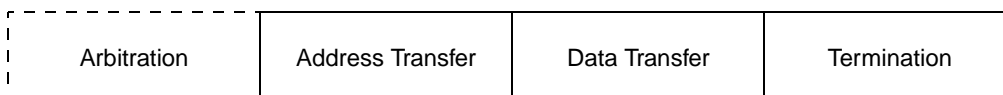

Figure 30-8. Basic Transfer Protocol

The arbitration phase is where bus ownership is requested and granted. This phase is not needed in Single Master Mode because the EBI is the permanent bus owner in this mode.

The address transfer phase specifies the address for the transaction and the transfer attributes that describe the transaction. The signals related to the address transfer phase are $\overline{D_TS}$, D_ADD (or D_ADD_DAT if Address/Data multiplexing is used), $\overline{CS}[0:3]$, D_RD_WR , and $\overline{D_BDIP}$. The address and its related signals (with the exception of $\overline{D_TS}$, $\overline{D_BDIP}$) are driven on the bus with the assertion of the $\overline{D_TS}$ signal, and kept valid until the bus master receives $\overline{D_TA}$ asserted (the EBI holds them one cycle beyond $\overline{D_TA}$ for writes and external $\overline{D_TA}$ accesses). Note that for writes with internal $\overline{D_TA}$, D_RD_WR is not held one cycle past $\overline{D_TA}$.

The data transfer phase performs the transfer of data, from master to slave (in write cycles) or from slave to master (on read cycles), if any is to be transferred. The data phase may transfer a single beat of data (1-4 bytes) for non-burst operations or a 2-beat (special $DBM=1$ case only), 4-beat, 8-beat, or 16-beat burst of data (2 or 4 bytes per beat depending on Port Size) when burst is enabled. On a write cycle, the master must not drive write data until after the address transfer phase is complete. This is to avoid electrical contentions when switching between drivers. The master must start driving write data one cycle after the address transfer cycle. The master can stop driving the data bus as soon as it samples the $\overline{D_TA}$ line asserted on the rising edge of D_CLKOUT . To facilitate asynchronous write support, the EBI keeps driving valid write data on the data bus until 1 clock after the rising edge where D_RD_WR and \overline{WE} are negated (for chip-select accesses only). See [Figure 30-14](#) for an example of write timing. On a read cycle, the master accepts the data bus contents as valid on the rising edge of the D_CLKOUT in which the $\overline{D_TA}$ signal is sampled asserted. See [Figure 30-10](#) for an example of read timing.

The termination phase is where the cycle is terminated by the assertion of either $\overline{D_TA}$ (normal termination) or $\overline{D_TEA}$ (termination with error). Termination is discussed in detail in [Section 30.4.2.8, Termination Signals Protocol](#).

30.4.2.4 Single Beat Transfer

The flow and timing diagrams in this section assume that the EBI is configured in Single Master Mode. Therefore, arbitration is not needed and is not shown in these diagrams.

30.4.2.4.1 Single Beat Read Flow

The handshakes for a single beat read cycle are illustrated in the following flow and timing diagrams.

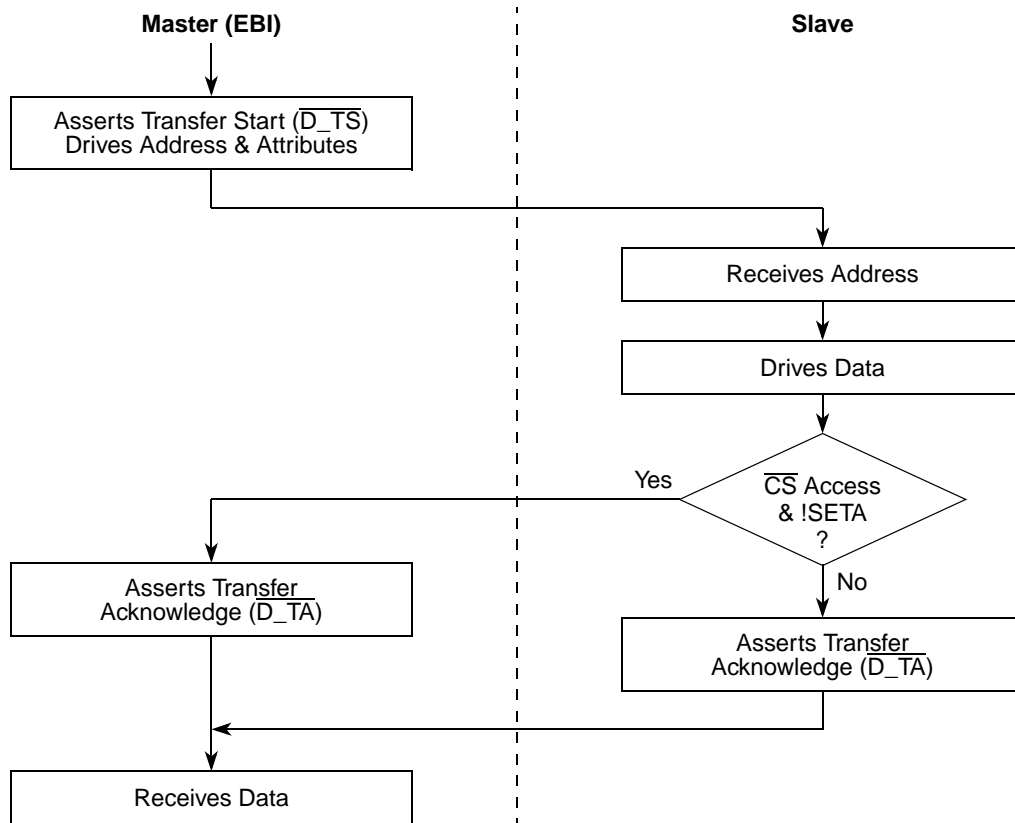

Figure 30-9. Basic Flow Diagram of a Single Beat Read Cycle

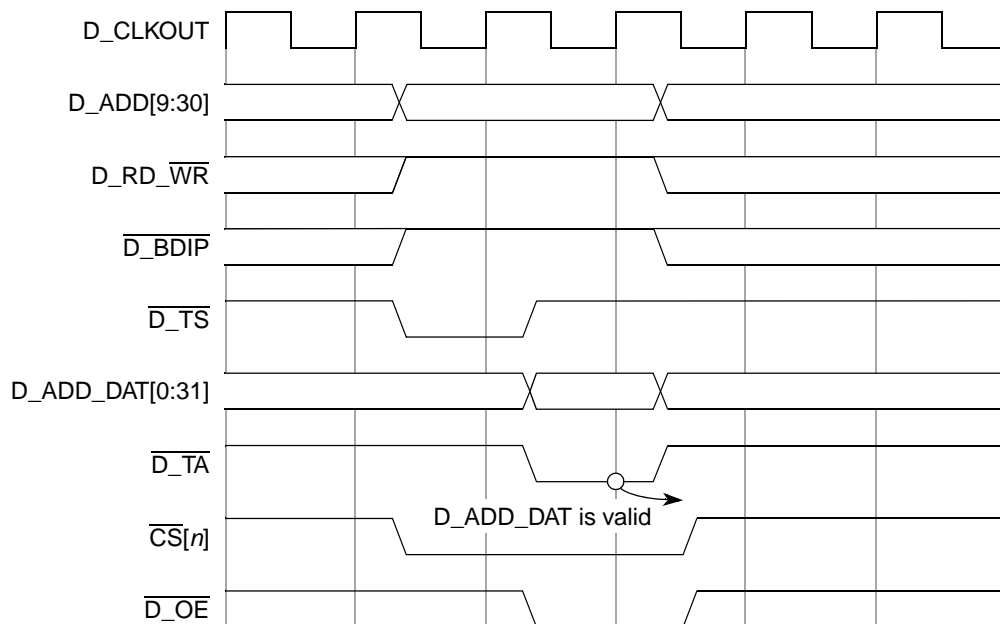

Figure 30-10. Single Beat 32-bit Read Cycle, \overline{CS} Access, Zero Wait States

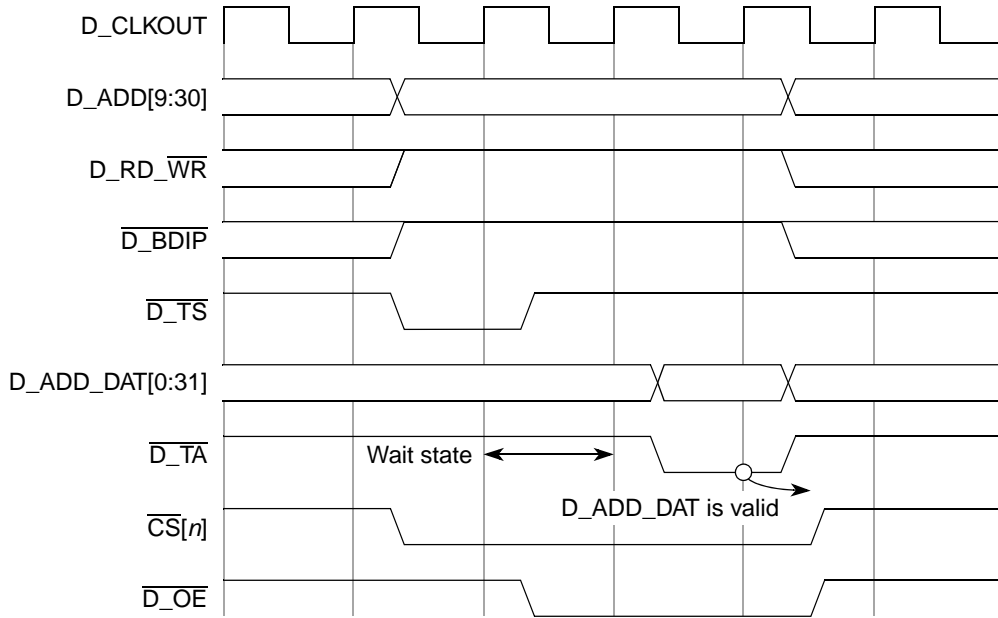
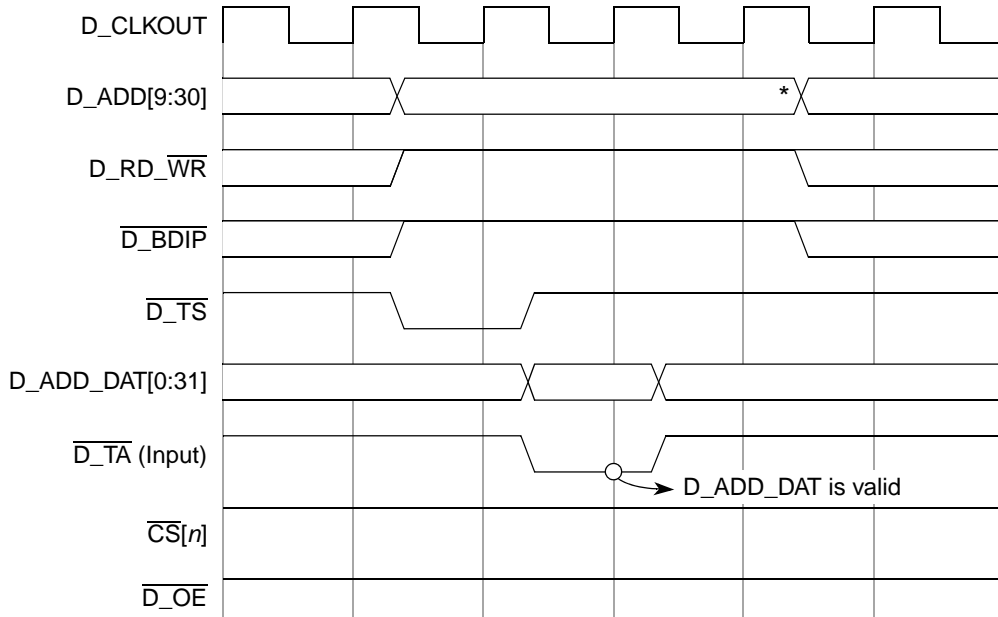

Figure 30-11. Single Beat 32-bit Read Cycle, \overline{CS} Access, One Wait State



* The EBI drives address and control signals an extra cycle because it uses a latched version of the external $\overline{D_TA}$ (1 cycle delayed) to terminate the cycle.

Figure 30-12. Single Beat 32-bit Read Cycle, Non- \overline{CS} Access, Zero Wait States

30.4.2.4.2 Single Beat Write Flow

The handshakes for a single beat write cycle are illustrated in the following flow and timing diagrams.

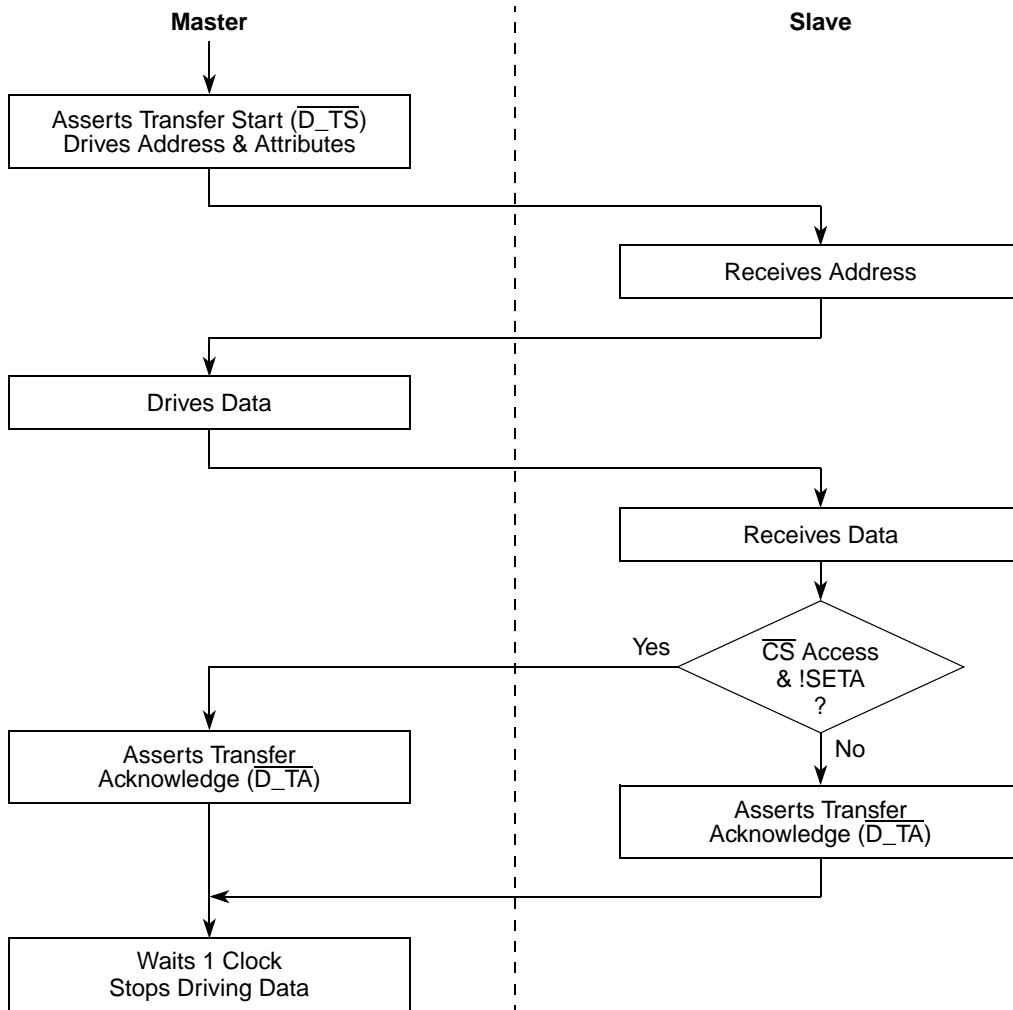

Figure 30-13. Basic Flow Diagram of a Single Beat Write Cycle

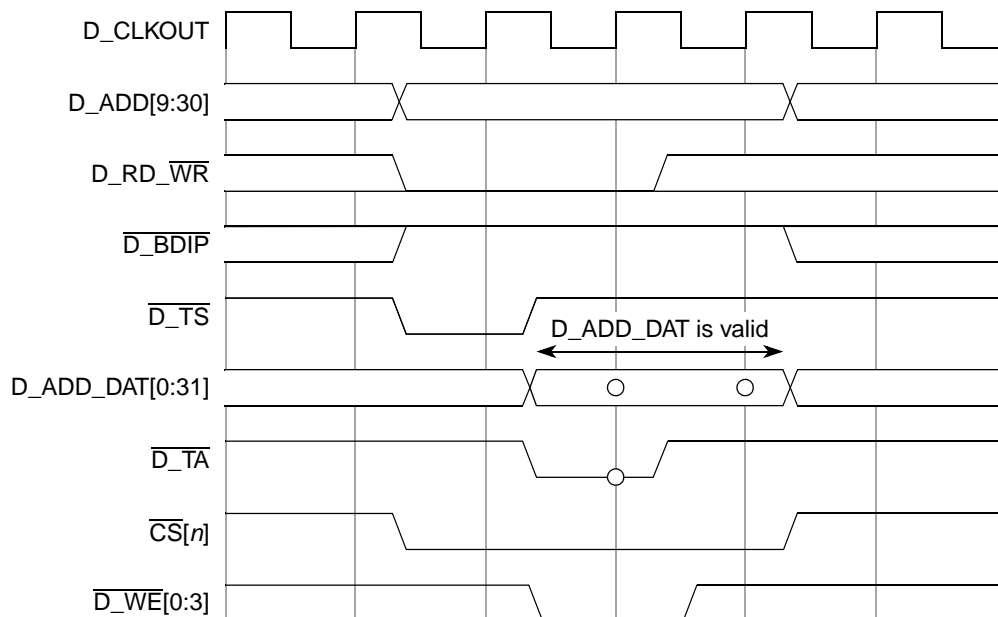

Figure 30-14. Single Beat 32-bit Write Cycle, \overline{CS} Access, Zero Wait States

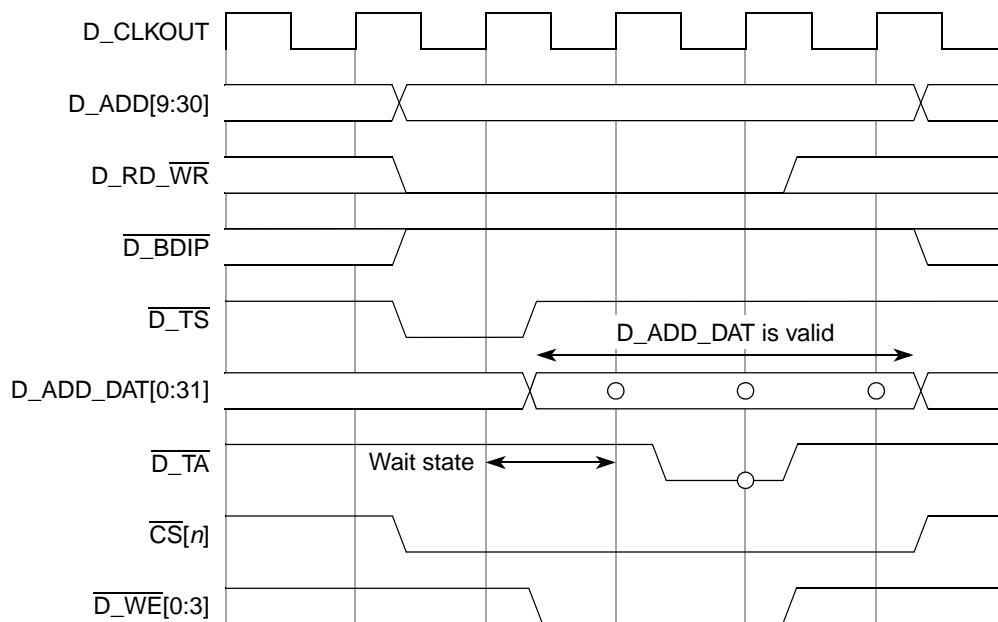
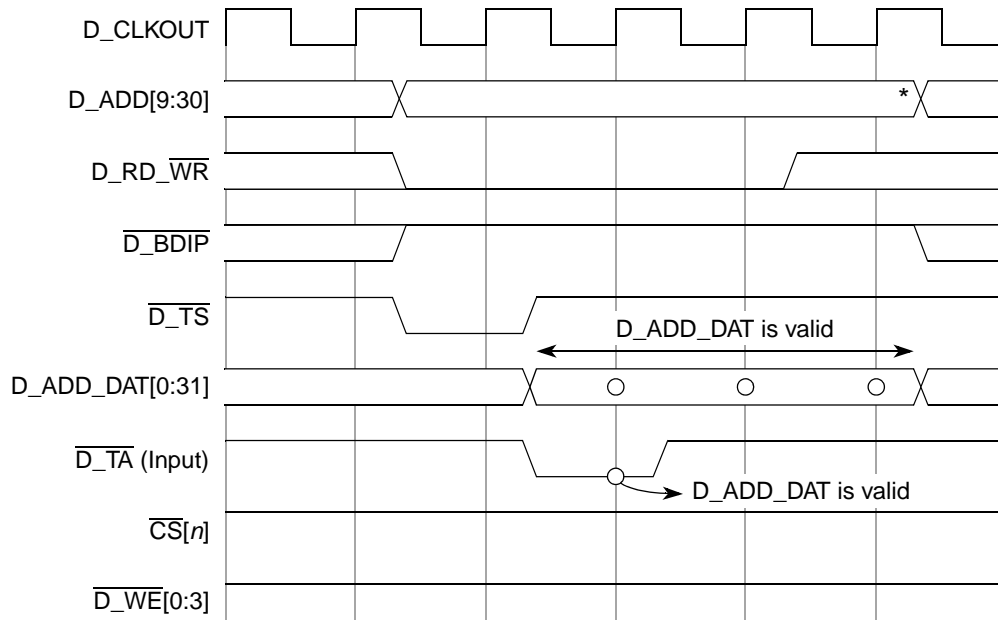

Figure 30-15. Single Beat 32-bit Write Cycle, \overline{CS} Access, One Wait State



* The EBI drives address and control signals an extra cycle because it uses a latched version of the external $\overline{D_TA}$ (1 cycle delayed) to terminate the cycle.

Figure 30-16. Single Beat 32-bit Write Cycle, Non- \overline{CS} Access, Zero Wait States

30.4.2.4.3 Back-to-Back Accesses

Due to internal bus protocol, one dead cycle is necessary between back-to-back external bus accesses that are not part of a set of small accesses (see [Section 30.4.2.6, Small Accesses \(Small Port Size and Short Burst Length\)](#) for small access timing). A dead cycle refers to a cycle between the $\overline{D_TA}$ of a previous transfer and the $\overline{D_TS}$ of the next transfer.

NOTE

In some cases, \overline{CS} remains asserted during this dead cycle, such as the cases of back-to-back writes or read-after-write to the same chip-select. See [Figure 30-20](#) and [Figure 30-21](#).

Besides this dead cycle, in most cases, back-to-back accesses on the external bus do not cause any change in the timing from that shown in the previous diagrams, and the two transactions are independent of each other. The only exceptions to this are listed below:

- Back-to-back accesses where the first access ends with an externally-driven $\overline{D_TA}$ or $\overline{D_TEA}$. In these cases, an extra cycle is required between the end of the first access and the $\overline{D_TS}$ assertion of the second access. See [Section 30.4.2.8, Termination Signals Protocol](#) for more details.

The following diagrams show a few examples of back-to-back accesses on the external bus.

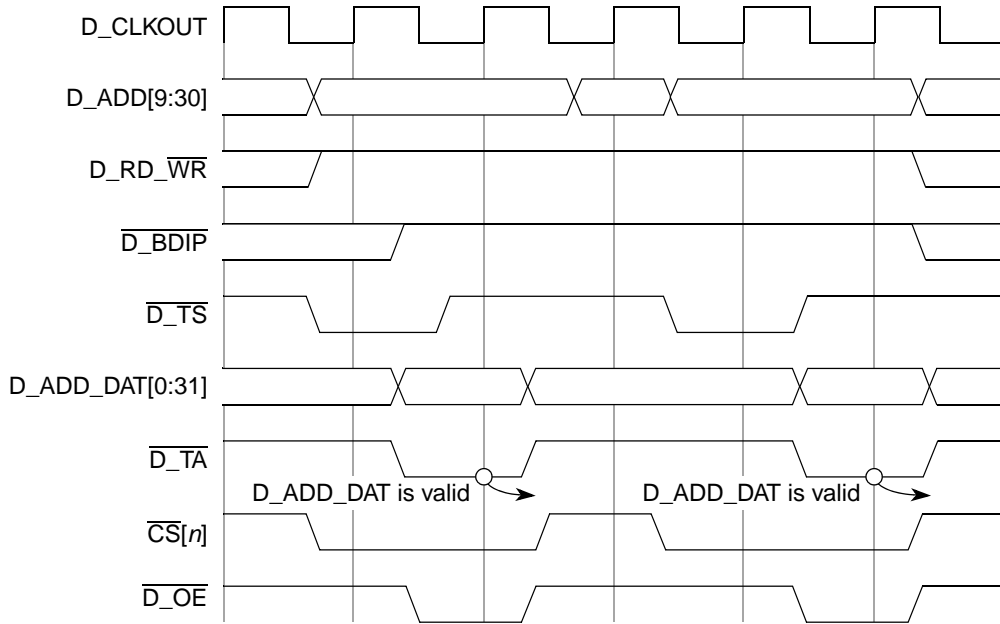

Figure 30-17. Back-to-Back 32-bit Reads to the Same \overline{CS} Bank

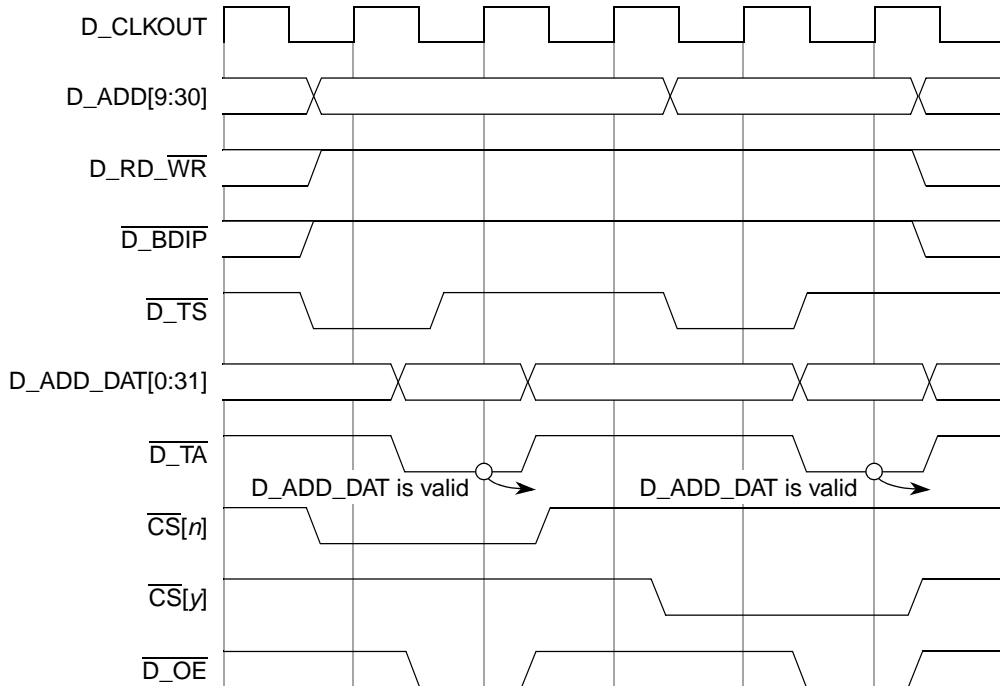

Figure 30-18. Back-to-Back 32-bit Reads to Different \overline{CS} Banks

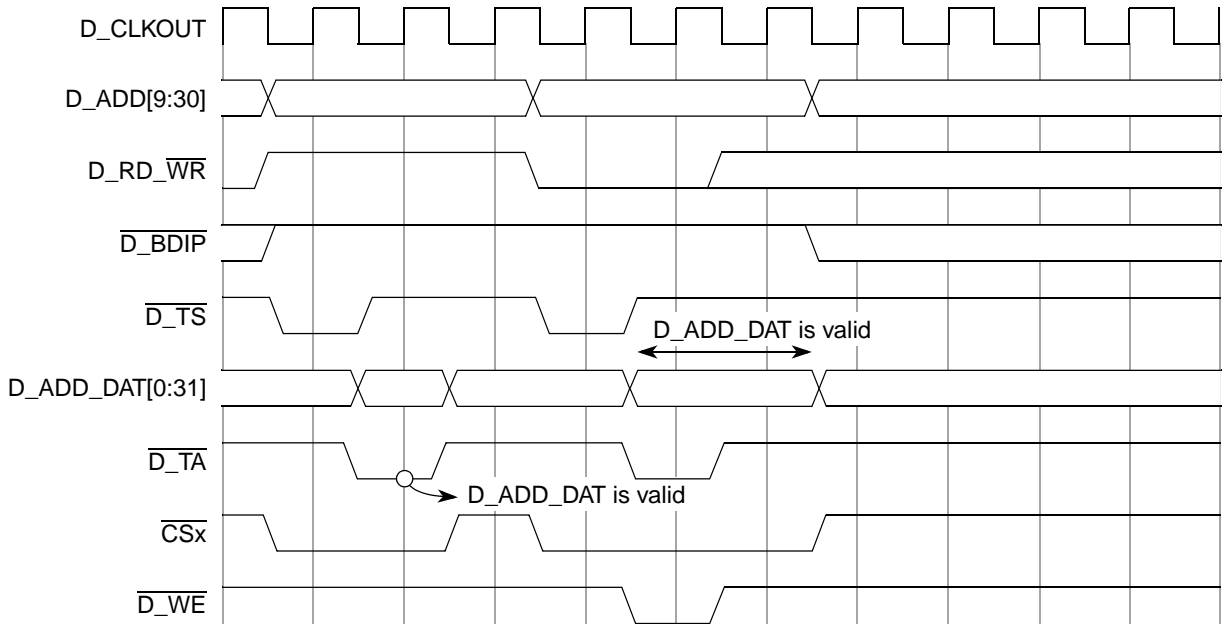

Figure 30-19. Write After Read to the Same \overline{CS} Bank

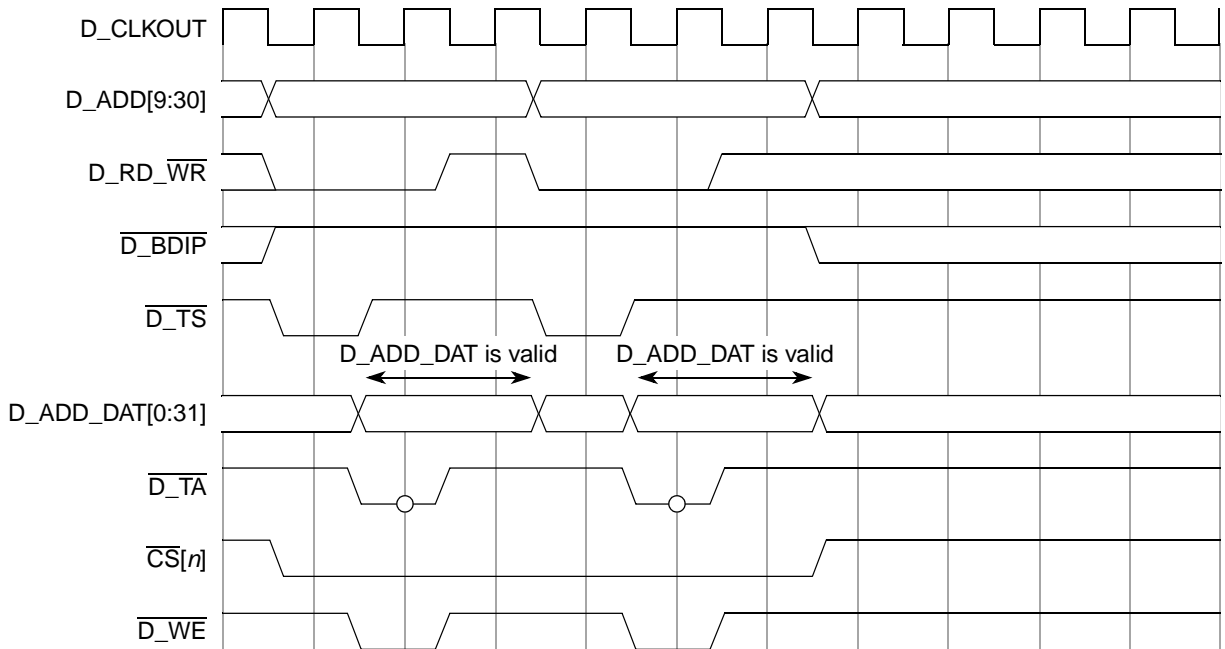

Figure 30-20. Back-to-Back 32-bit Writes to the Same \overline{CS} Bank

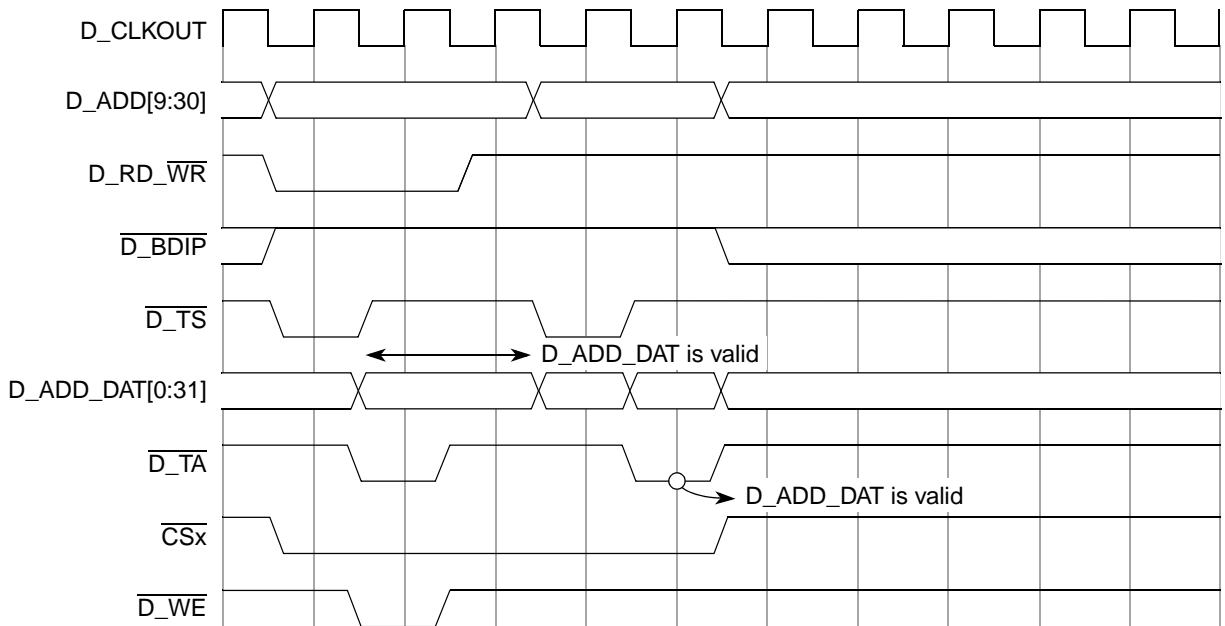

Figure 30-21. Read After Write to the Same \overline{CS} Bank

30.4.2.5 Burst Transfer

The EBI supports wrapping 32-byte critical-doubleword-first burst transfers. Bursting is supported only for internally-requested cache-line size (32-byte) read accesses to external devices that use the chip selects¹.

Accesses to devices operating without a chip select are always single beat. If an internal request to the EBI indicates a size of less than 32 bytes, the request is fulfilled by running one or more single-beat external transfers, not by an external burst transfer.

An 8-word wrapping burst reads eight 32-bit words by supplying a starting address that points to one of the words (doubleword aligned) and requiring the memory device to sequentially drive each word on the data bus. The selected slave device must internally increment **D_ADD[27:29]** (also **D_ADD30** in the case of a 16-bit port size device) of the supplied address for each transfer, until the address reaches an 8-word boundary, and then wrap the address to the beginning of the 8-word boundary. The address and transfer attributes supplied by the EBI remain stable during the transfers. Termination of each beat transfer occurs by the EBI asserting $\overline{D_TA}$ (**SETA=1** is not supported for burst transfers). The EBI requires that addresses be aligned to a doubleword boundary on all burst cycles.

Table 30-13 shows the burst order of beats returned for an 8-word burst to a 32-bit port.

1. Except for the special case of a 32-bit non-chip-select access in 16-bit data bus mode. See Section 30.4.2.9, Non-Chip-Select Burst in 16-bit Data Bus Mode.

Table 30-13. Wrap Bursts Order

| Burst Starting Address D_ADD[27:28] | Burst Order (Assuming 32-bit Port Size) |
|--|--|
| 00 | word0 -> word1 -> word2 -> word3 -> word4 -> word5 -> word6 -> word7 |
| 01 | word2 -> word3 -> word4 -> word5 -> word6 -> word7 -> word0 -> word1 |
| 10 | word4 -> word5 -> word6 -> word7 -> word0 -> word1 -> word2 -> word3 |
| 11 | word6 -> word7 -> word0 -> word1 -> word2 -> word3 -> word4 -> word5 |

The general case of burst transfers assumes that the external memory has 32-bit port size and 8-word burst length. The EBI can also burst from 16-bit port size memories, taking twice as many external beats to fetch the data as compared to a 32-bit port with the same burst length. The EBI can also burst from 16-bit or 32-bit memories that have a 4-word burst length (BL=1 in the appropriate Base Register). In this case, two external 4-word burst transfers (wrapping on 4-word boundary) are performed to fulfill the internal 8-word request¹. This operation is considered atomic by the EBI, so the EBI does not allow other unrelated master accesses or bus arbitration to intervene between the transfers. For more details and a timing diagram, see [Section 30.4.2.6.3, Small Access Example #3: 32-byte Read to 32-bit Port with BL=1](#).

During burst cycles, the $\overline{D_BDIP}$ (Burst Data In Progress) signal is used to indicate the duration of the burst data. During the data phase of a burst read cycle, the EBI receives data from the addressed slave. If the EBI needs more than one data, it asserts the $\overline{D_BDIP}$ signal. Upon receiving the data prior to the last data, the EBI negates $\overline{D_BDIP}$. Thus, the slave stops driving new data after it receives the negation of $\overline{D_BDIP}$ on the rising edge of the clock. Some slave devices have their burst length and timing configurable internally and thus may not support connecting to a $\overline{D_BDIP}$ pin. In this case, $\overline{D_BDIP}$ is driven by the EBI normally, but the output is ignored by the memory and the burst data behavior is determined by the internal configuration of the EBI and slave device. When the TBDIP bit is set in the appropriate Base Register, the timing for $\overline{D_BDIP}$ is altered. See [Section 30.4.2.5.1, TBDIP Effect on Burst Transfer](#) for this timing.

Since burst writes are not supported by the EBI², the EBI negates $\overline{D_BDIP}$ during write cycles.

1. This case (of 2 external burst transfers being required) applies only to AMBA data bus width of 64 bits.
2. Except for the special case of a 32-bit non-chip-select access in 16-bit data bus mode. See [Section 30.4.2.9, Non-Chip-Select Burst in 16-bit Data Bus Mode](#).

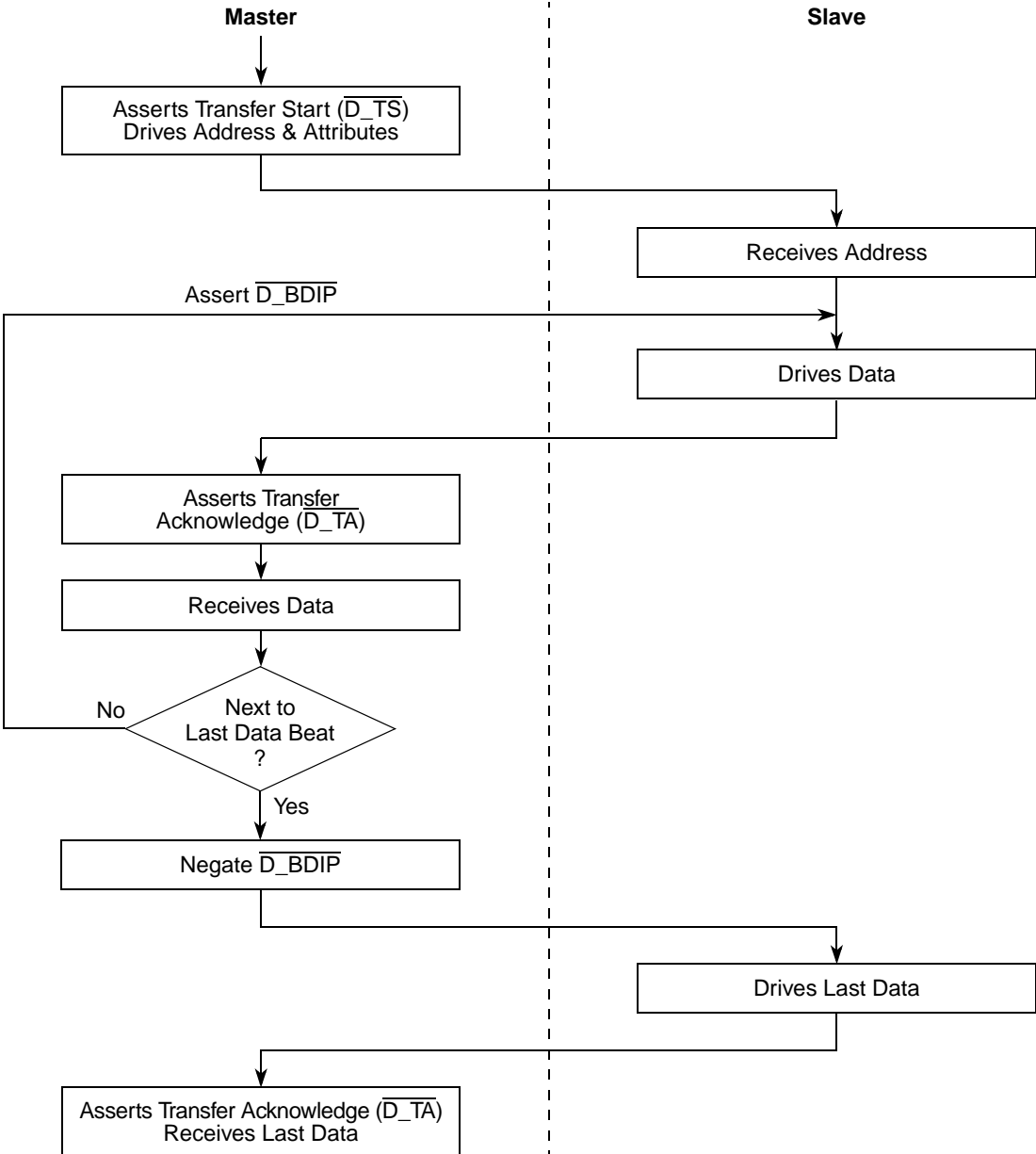
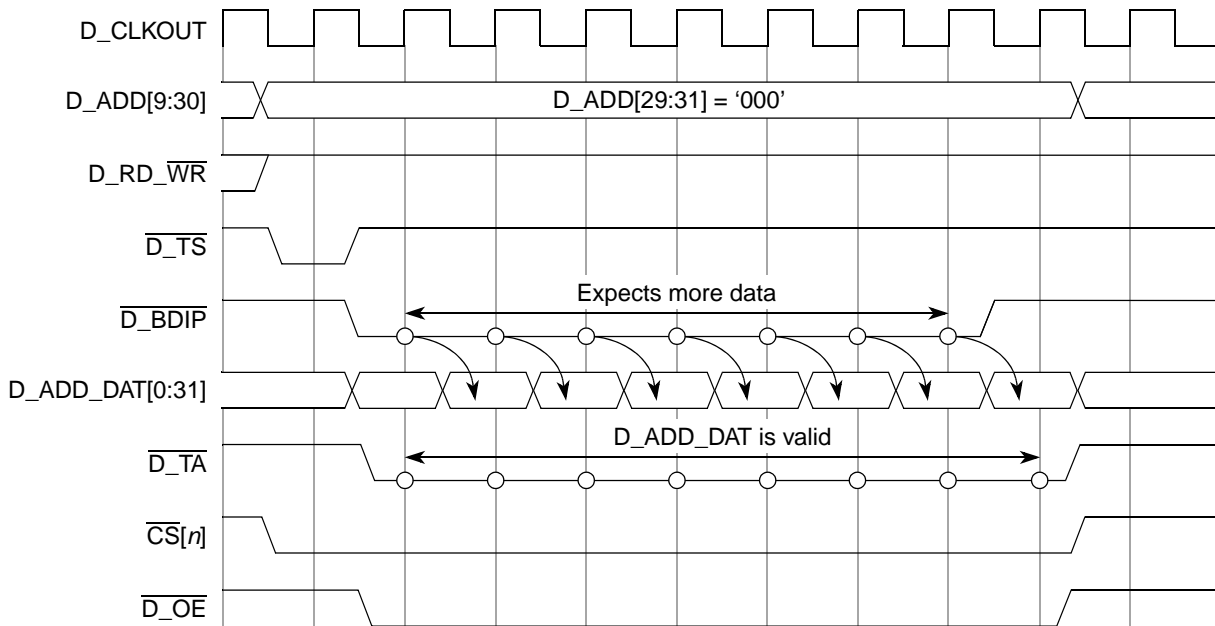
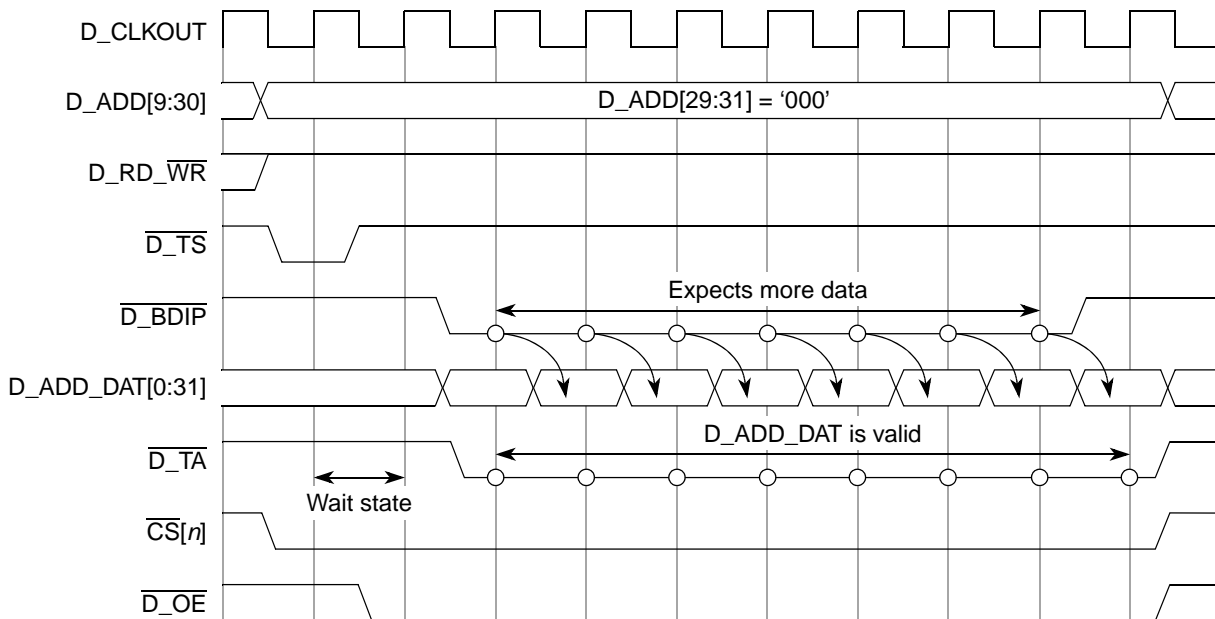

Figure 30-22. Basic Flow Diagram of a Burst Read Cycle

Figure 30-23. Burst 32-bit Read Cycle, Zero Wait States

Figure 30-24. Burst 32-bit Read Cycle, One Initial Wait State

30.4.2.5.1 TBDIP Effect on Burst Transfer

Some memories require different timing on the $\overline{D_BDIP}$ signal than the default to run burst cycles. Using the default value of TBDIP=0 in the appropriate EBI Base Register results in $\overline{D_BDIP}$ being asserted (SCY+1) cycles after the address transfer phase, and being held asserted throughout the cycle regardless of the wait states between beats (BSCY). [Figure 30-25](#) shows an example of the TBDIP=0 timing for a 4-beat burst with BSCY=1.

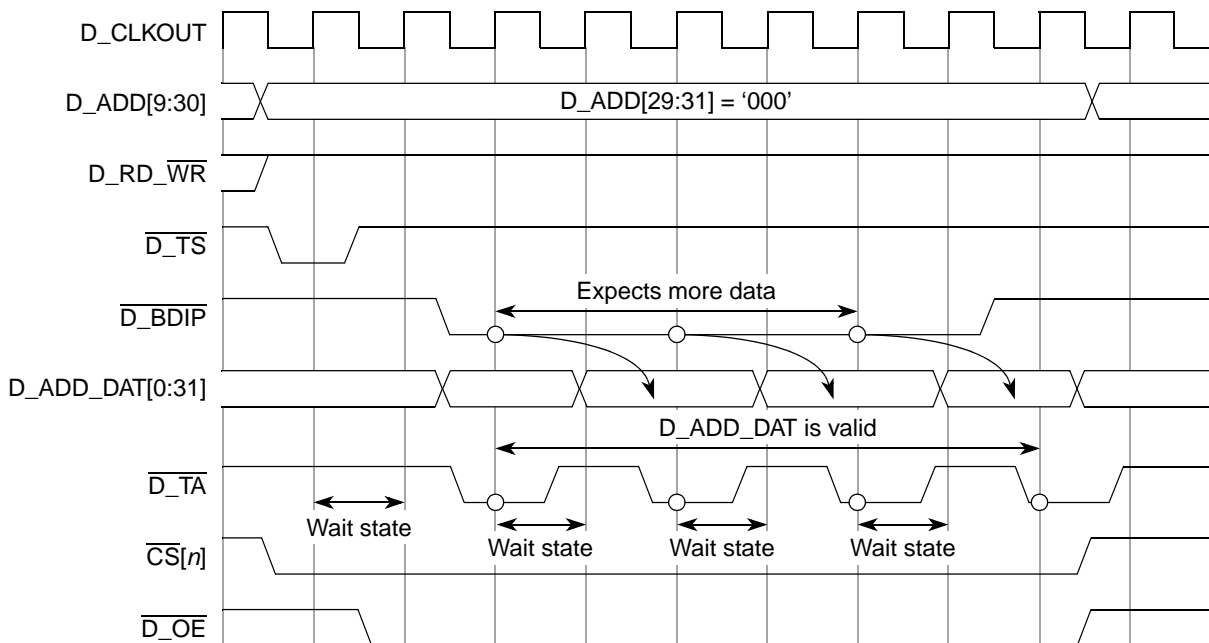

Figure 30-25. Burst 32-bit Read Cycle, One Wait State between Beats, TBDIP=0

When using TBDIP=1, the $\overline{D_BDIP}$ behavior changes to toggle between every beat when BSCY is a non-zero value. Figure 30-26 shows an example of the TBDIP=1 timing for the same 4-beat burst shown in Figure 30-25.

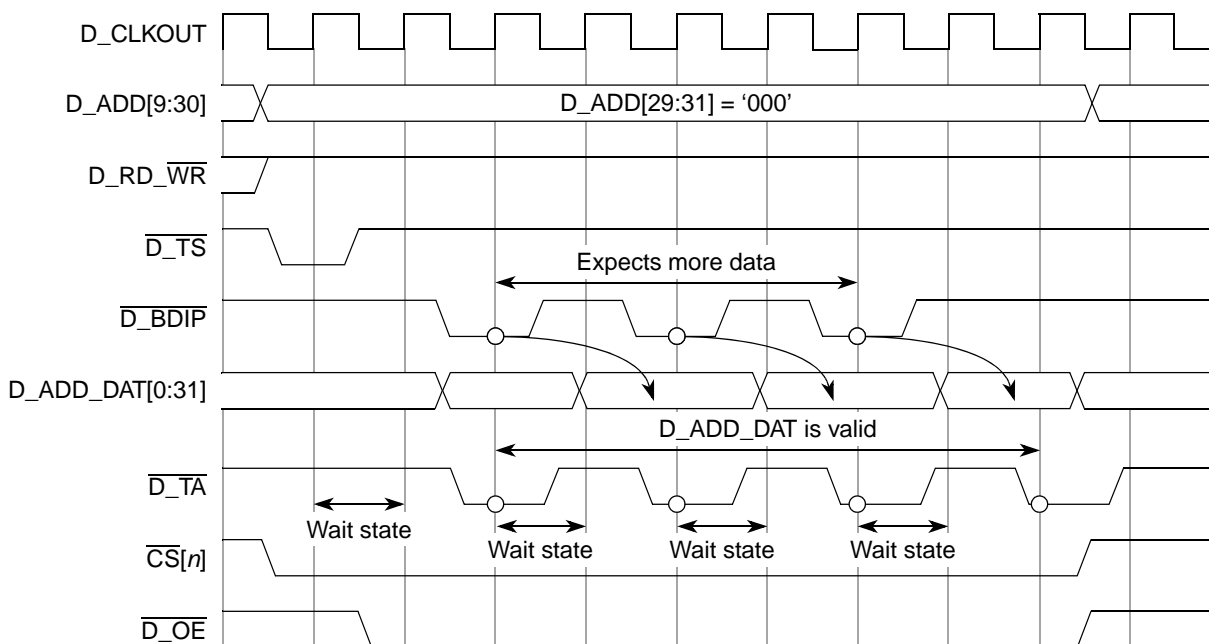

Figure 30-26. Burst 32-bit Read Cycle, One Wait State between Beats, TBDIP=1

30.4.2.6 Small Accesses (Small Port Size and Short Burst Length)

In this context, a *small access* refers to an access whose burst length and port size (BL, PS bits in Base Register for chip-select access or default burst disabled, 32-bit port for non-chip-select access) are such that the number of bytes requested by the internal master cannot all be fetched (or written) in one external transaction. If this is the case, the EBI initiates multiple transactions until all the requested data is transferred. It should be noted that all the transactions initiated to complete the data transfer are considered as an atomic transaction, so the EBI does not allow other unrelated master accesses to intervene between the transfers.

Table 30-14 shows all the combinations of burst length, port size, and requested byte count that cause the EBI to run multiple external transactions to fulfill the request.

Table 30-14. Small Access Cases

| Byte Count Requested by internal master | Burst Length | Port Size | # External Accesses to Fulfill Request |
|--|--------------|------------------------------------|--|
| Non-Burstable Chip-Select Banks (BI=1) or Non-Chip-Select Access | | | |
| 4 | 1 beat | 16-bit | 2/1 ¹ |
| 8 | 1 beat | 32-bit | 2 |
| 8 | 1 beat | 16-bit | 4 |
| 32 ² | 1 beat | 32-bit | 8 |
| 32 ² | 1 beat | 16-bit | 16 |
| Burstable Chip-Select Banks (BI=0) | | | |
| 32 ² | 4 words | 16-bit (8 beats), 32-bit (4 beats) | 2 |

¹ In 32-bit data bus mode (DBM=0 in EBI_MCR), two accesses are performed. In 16-bit data bus mode (DBM=1), one 2-beat burst access is performed and this is not considered a “small access” case. See Section 30.4.2.9, [Non-Chip-Select Burst in 16-bit Data Bus Mode](#) for this special DBM=1 case.

² Only supported for case of 64-bit internal AMBA data bus.

In most cases, the timing for small accesses is the same as for normal single-beat and burst accesses, except that multiple back-to-back external transfers are executed for each internal request. These transfers have no additional dead cycles in-between that are not present for back-to-back stand-alone transfers except for the case of writes with an internal request size of >64 bits, discussed in Section 30.4.2.6.2, [Small Access Example #2: 32-byte Write with External D_TA](#).

The following sections show a few examples of small accesses. The timing for the remaining cases in Table 30-14 can be extrapolated from these and the other timing diagrams in this document.

30.4.2.6.1 Small Access Example #1: 32-bit Write to 16-bit Port

Figure 30-27 shows an example of a 32-bit write to a 16-bit port, requiring two 16-bit external transactions.

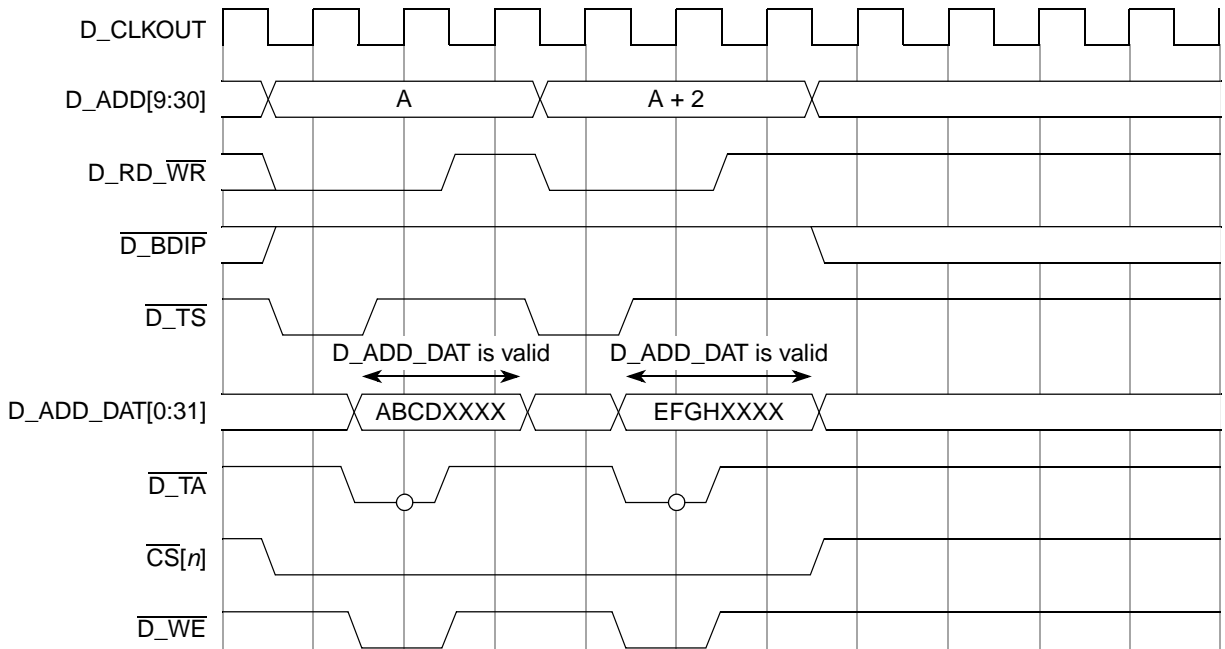
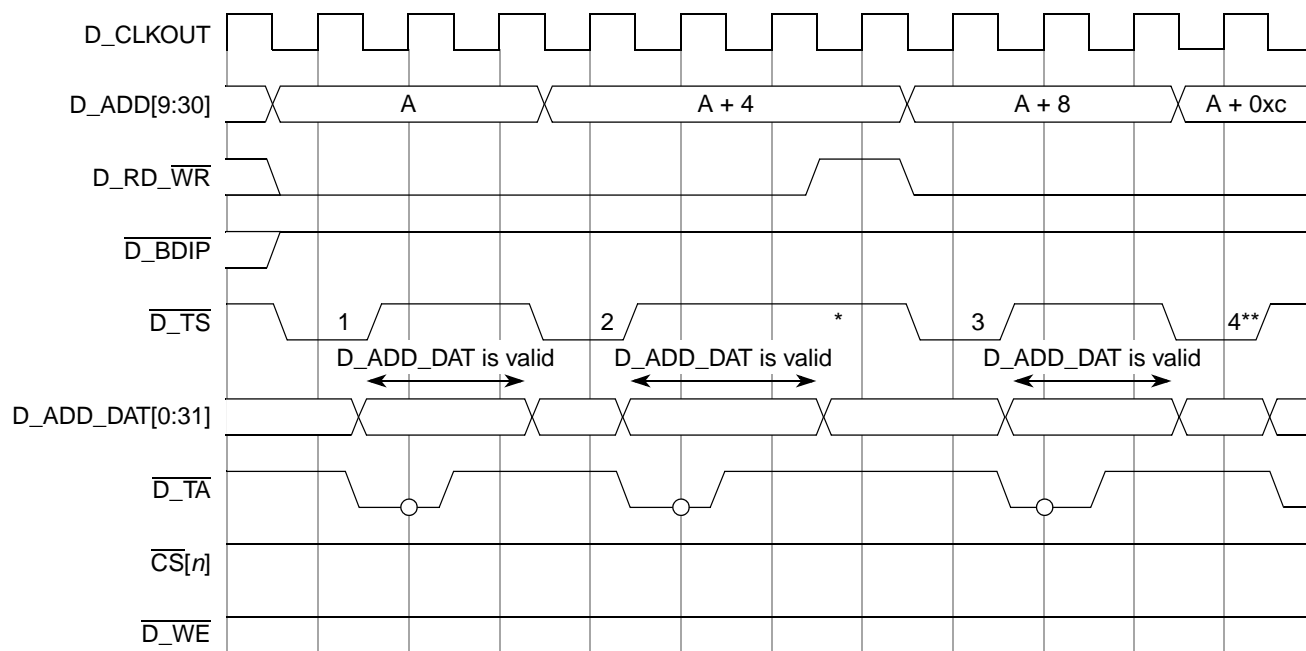

Figure 30-27. Single Beat 32-bit Write Cycle, 16-bit Port Size, Basic Timing

30.4.2.6.2 Small Access Example #2: 32-byte Write with External $\overline{D_TA}$

Figure 30-28 shows an example of a 32-byte write to a non-chip-select device using external $\overline{D_TA}$, requiring eight 32-bit external transactions. Note that due to the use of external $\overline{D_TA}$, $\overline{D_RD_WB}$ does not toggle between the accesses unless that access is the end of a 64-bit boundary. In this case, an extra cycle is required between $\overline{D_TA}$ and the next $\overline{D_TS}$ in order to get the next 64-bits of write data internally and $\overline{D_RD_WB}$ negates during this extra cycle.



* This extra cycle is required after accesses 2, 4, and 6 to get the next 64-bits of internal write data.

** Four more external accesses (not shown) are required to complete the internal 32-byte request. The timing of these is the same as accesses 1-4 shown in this diagram.

Figure 30-28. 32-Byte Write Cycle with External $\overline{D_TA}$, Basic Timing

30.4.2.6.3 Small Access Example #3: 32-byte Read to 32-bit Port with BL=1

Figure 30-29 shows an example of a 32-byte read to a 32-bit burst enabled port with burst length of 4 words, requiring two 16-byte external transactions. For this case, the address for the 2nd 4-word burst access is calculated by adding 0x10 to the lower 5 bits of the 1st address (no carry), and then masking out the lower 4 bits to fix them at zero.

Table 30-15. Examples of 4-word Burst Addresses

| 1st Address | Lower 5 bits of 1st Address + 0x10 (no carry) | Final 2nd Address (After Masking Lower 4 Bits) |
|-------------|---|--|
| 0x000 | 0x10 | 0x10 |
| 0x008 | 0x18 | 0x10 |
| 0x010 | 0x00 | 0x00 |
| 0x018 | 0x08 | 0x00 |
| 0x020 | 0x30 | 0x30 |
| 0x028 | 0x38 | 0x30 |
| 0x030 | 0x20 | 0x20 |
| 0x038 | 0x28 | 0x20 |

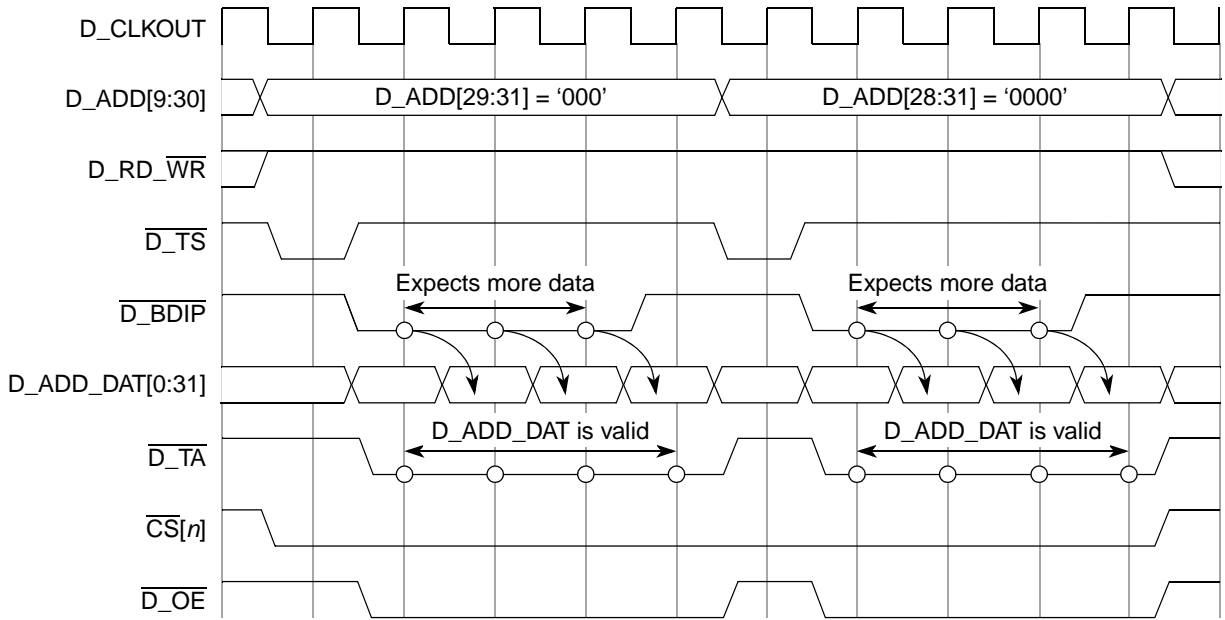
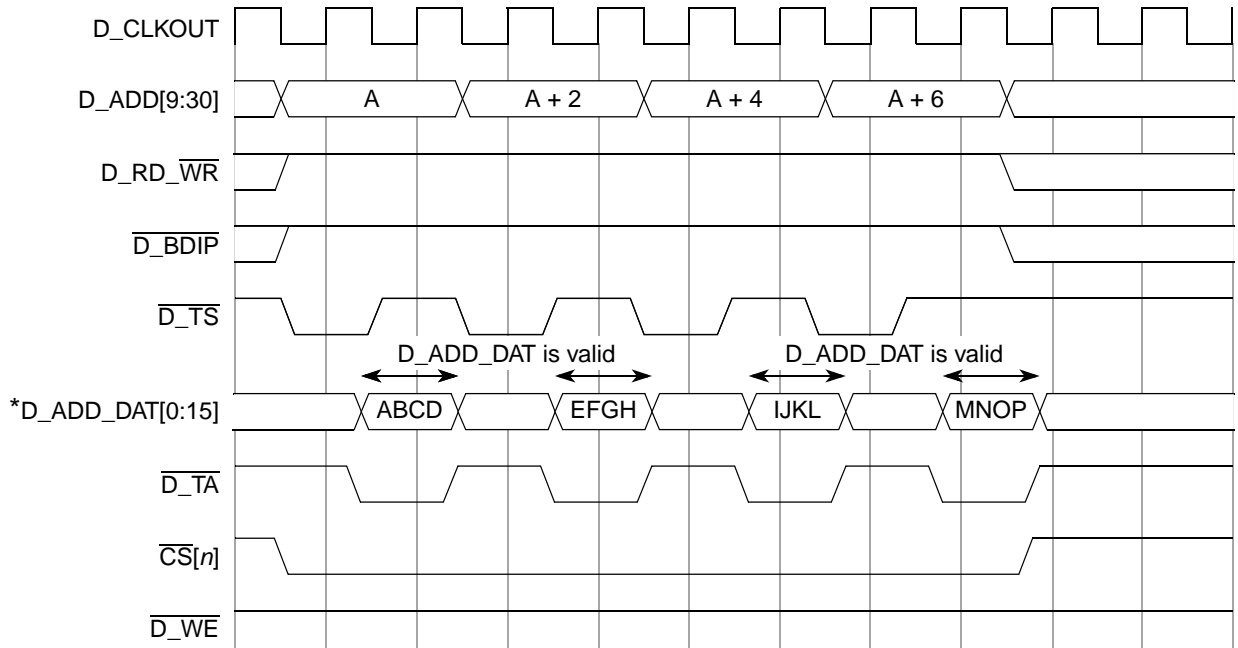

Figure 30-29. 32-Byte Read with B-T-B 16-Byte Bursts to 32-bit Port, Zero Wait States

30.4.2.6.4 Small Access Example #4: 64-bit Read to 16-bit Port

Figure 30-30 shows an example of a 64-bit read to a 16-bit port, requiring four 16-bit external transactions.



*Or D_ADD_DAT[16:31], based on D16_31 bit in EBI_MCR.

Figure 30-30. Single Beat 64-bit Read Cycle, 16-bit Port Size, Basic Timing

30.4.2.7 Size, Alignment and Packaging on Transfers

Table 30-16 shows the allowed sizes that an internal master can request from the EBI. The behavior of the EBI for request sizes not shown below is undefined. No error signal is asserted for these erroneous cases.

Table 30-16. Transaction Sizes Supported by EBI

| # Bytes (internal master) |
|---------------------------|
| 1 |
| 2 |
| 4 |
| 3 ¹ |
| 8 |
| 32 |

¹ Some misaligned access cases may result in 3-byte writes. These cases are treated as power-of-2 sized requests by the EBI, using $\overline{D_WE}[0:3]$ to make sure only the appropriate 3 bytes get written.

Even though misaligned non-burst transfers from internal masters are supported, the EBI naturally aligns the accesses when it sends them out to the external bus, splitting them into multiple aligned accesses if necessary. See Section 30.4.2.11, [Misaligned Access Support](#) for these cases.

Natural alignment for the EBI means:

- Byte access can have any address
- 16-bit access, address bit 31 must be 0
- 32-bit access, address bits 30-31 must be 0
- For burst accesses of any size, address bits 29-31 must be 0

The EBI never generates a misaligned external access, so a multi-master system with two e200-based MCUs can never have a misaligned external access from one to the other. In the erroneous case that an externally-initiated misaligned access does occur, the EBI errors the access (by asserting $\overline{D_TEA}$ externally) and does not initiate the access on the internal bus.

The EBI requires that the portion of the data bus used for a transfer to/from a particular port size be fixed. A 32-bit port must reside on data bus bits 0-31, and a 16-bit port must reside on bits 0-15.

In the following figures and tables the following convention is adopted:

- The most significant byte of a 32-bit operand is OP0, and OP3 is the least significant byte.
- The two bytes of a 16-bit operand are OP0 (most significant) and OP1, or OP2 (most significant) and OP3, depending on the address of the access.
- The single byte of a byte-length operand is OP0, OP1, OP2, or OP3, depending on the address of the access.

This can be seen in [Figure 30-31](#).

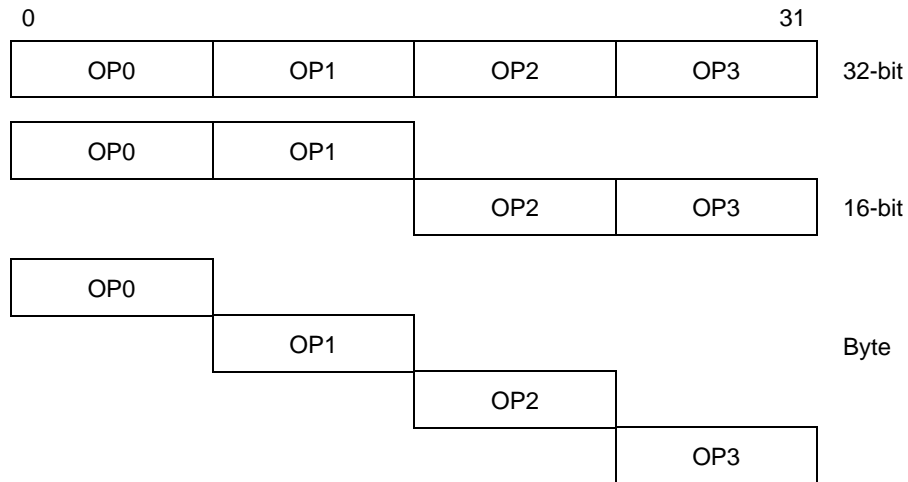

Figure 30-31. Internal Operand Representation

Figure 30-32 shows the device connections on the D_ADD_DAT[0:31] bus.

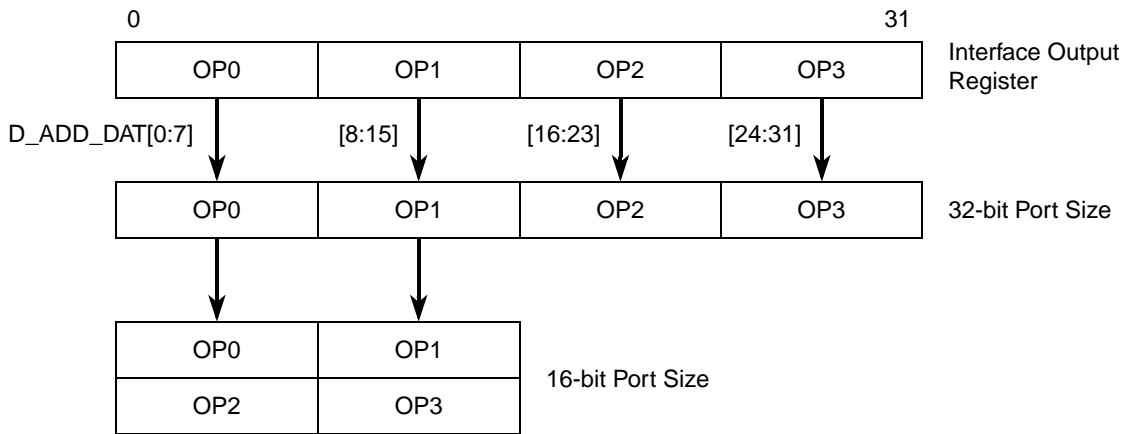

Figure 30-32. Interface to Different Port Size Devices

Table 30-17 lists the bytes required on the data bus for read cycles. The bytes indicated as ‘-’ are not required during that read cycle.

Table 30-17. Data Bus Requirements for Read Cycles

| Transfer Size | Address | | 32-Bit Port Size | | | | 16-Bit Port Size ¹ | |
|---------------|---------|-----|------------------|--------|---------|---------|-------------------------------|---------------------|
| | A30 | A31 | D0:D7 | D8:D15 | D16:D23 | D24:D31 | D0:D7 ² | D8:D15 ³ |
| Byte | 0 | 0 | OP0 | — | — | — | OP0 | — |
| | 0 | 1 | — | OP1 | — | — | — | OP1 |
| | 1 | 0 | — | — | OP2 | — | OP2 | — |
| | 1 | 1 | — | — | — | OP3 | — | OP3 |
| 16-bit | 0 | 0 | OP0 | OP1 | — | — | OP0 | OP1 |
| | 1 | 0 | — | — | OP2 | OP3 | OP2 | OP3 |
| 32-bit | 0 | 0 | OP0 | OP1 | OP2 | OP3 | OP0 or OP2 ⁴ | OP1 or OP3 |

- ¹ Also applies when DBM=1 for 16-bit data bus mode.
- ² For address/data muxed transfers, D_ADD_DAT[16:23] are used externally, not D_ADD_DAT[0:7].
- ³ For address/data muxed transfers, D_ADD_DAT[24:31] are used externally, not D_ADD_DAT[8:15].
- ⁴ This case consists of two 16-bit external transactions, the first fetching OP0 and OP1, the second fetching OP2 and OP3.

Table 30-18 lists the patterns of the data transfer for write cycles when accesses are initiated by the MCU. The bytes indicated as ‘—’ are not driven during that write cycle.

Table 30-18. Data Bus Contents for Write Cycles

| Transfer Size | Address | | 32-Bit Port Size | | | | 16-Bit Port Size ¹ | |
|---------------|---------|-----|------------------|--------|---------|---------|-------------------------------|---------------------|
| | A30 | A31 | D0:D7 | D8:D15 | D16:D23 | D24:D31 | D0:D7 ² | D8:D15 ³ |
| Byte | 0 | 0 | OP0 | — | — | — | OP0 | — |
| | 0 | 1 | OP1 | OP1 | — | — | — | OP1 |
| | 1 | 0 | OP2 | — | OP2 | — | OP2 | — |
| | 1 | 1 | OP3 | OP3 | — | OP3 | — | OP3 |
| 16-bit | 0 | 0 | OP0 | OP1 | — | — | OP0 | OP1 |
| | 1 | 0 | OP2 | OP3 | OP2 | OP3 | OP2 | OP3 |
| 32-bit | 0 | 0 | OP0 | OP1 | OP2 | OP3 | OP0 or OP2 ⁴ | OP1 or OP3 |

- ¹ Also applies when DBM=1 for 16-bit data bus mode.
- ² For address/data muxed transfers, D_ADD_DAT[16:23] are used externally, not D_ADD_DAT[0:7].
- ³ For address/data muxed transfers, D_ADD_DAT[24:31] are used externally, not D_ADD_DAT[8:15].
- ⁴ This case consists of two 16-bit external transactions, the first writing OP0 and OP1, the second writing OP2 and OP3.

30.4.2.8 Termination Signals Protocol

The termination signals protocol was defined in order to avoid electrical contention on lines that can be driven by various sources. In order to do that, a slave must not drive signals associated with the data transfer until the address phase is completed and it recognizes the address as its own. The slave must disconnect from signals immediately after it acknowledges the cycle and not later than the termination of the next address phase cycle.

For EBI-mastered non-chip-select accesses, the EBI requires assertion of $\overline{D_TA}$ from an external device to signal that the bus cycle is complete. The EBI uses a latched version of $\overline{D_TA}$ (1 cycle delayed) for these accesses to help make timing at high frequencies. This results in the EBI driving the address and control signals 1 cycle longer than required, as seen in Figure 30-33. However, the D_ADD_DAT does not need to be held 1 cycle longer by the slave, because the EBI latches D_ADD_DAT every cycle during non-chip-select accesses. During these accesses, the EBI does not drive the $\overline{D_TA}$ signal, leaving it up to an external device (or weak internal pullup) to drive $\overline{D_TA}$.

For EBI-mastered chip-select accesses, when the SETA bit is 0, the EBI drives $\overline{D_TA}$ the entire cycle, asserting according to internal wait state counters to terminate the cycle. When the SETA bit is 1, the EBI samples the $\overline{D_TA}$ for the entire cycle. During idle periods on the external bus, the EBI drives $\overline{D_TA}$ negated as long as it is granted the bus; when it no longer owns the bus, it lets go of $\overline{D_TA}$.

If no device responds by asserting $\overline{D_TA}$ within the programmed timeout period (BMT in EBI_BMCR) after the EBI initiates the bus cycle, the internal Bus Monitor (if enabled) asserts $\overline{D_TEA}$ to terminate the cycle. An external device may also drive $\overline{D_TEA}$ when it detects an error on an external transaction. $\overline{D_TEA}$ assertion causes the cycle to terminate and the processor to enter exception processing for the error condition. To properly control termination of a bus cycle for a bus error with external circuitry, $\overline{D_TEA}$ must be asserted at the same time or before (external) $\overline{D_TA}$ is asserted. $\overline{D_TEA}$ must be negated before the second rising edge after it was sampled asserted in order to avoid the detection of an error for the following bus cycle initiated. $\overline{D_TEA}$ is only driven by the EBI during the cycle where the EBI is asserting $\overline{D_TEA}$ and the cycle immediately following this assertion (for fast negation). During all other cycles, the EBI relies on a weak internal pullup to hold $\overline{D_TEA}$ negated. This allows an external device to assert $\overline{D_TEA}$ when it needs to indicate an error. External devices must follow the same protocol as the EBI, only driving $\overline{D_TEA}$ during the assertion cycle and 1 cycle afterwards for negation.

When $\overline{D_TEA}$ is asserted from an external source, the EBI uses a latched version of $\overline{D_TEA}$ (1 cycle delayed) to help make timing at high frequencies. This means that for any accesses where the EBI drives $\overline{D_TA}$ (chip-select accesses with SETA=0), a $\overline{D_TEA}$ assertion that occurs 1 cycle before or during the last $\overline{D_TA}$ of the access could be ignored by the EBI, since it will have completed the access internally before it detects the latched $\overline{D_TEA}$ assertion. This means that non-burst chip-select accesses with no wait states (SCY=0) cannot be reliably terminated by external $\overline{D_TEA}$. If external error termination is required for such a device, the EBI must be configured for SCY>=1.

NOTE

For the cases discussed above where $\overline{D_TEA}$ “could be ignored”, this is not guaranteed. For some small access cases (which always use chip-select and internally-driven $\overline{D_TA}$), a $\overline{D_TEA}$ that occurs 1 cycle before or during the $\overline{D_TA}$ cycle or for SCY=0 may in fact lead to terminating the cycle with error. However, proper error termination is not guaranteed for these cases, so $\overline{D_TEA}$ must always be asserted at least 2 cycles before an internally-driven $\overline{D_TA}$ cycle for proper error termination.

External $\overline{D_TEA}$ assertion that occurs during the same cycle that $\overline{D_TS}$ is asserted by the EBI is always treated as an error (terminating the access) regardless of SCY.

Table 30-19 summarizes how the EBI recognizes the termination signals provided from an external device.

Table 30-19. Termination Signals Protocol

| $\overline{D_TEA}^1$ | $\overline{D_TA}^1$ | Action |
|-----------------------|----------------------|-----------------------------|
| Negated | Negated | No Termination |
| Asserted | X | Transfer Error Termination |
| Negated | Asserted | Normal Transfer Termination |

¹ Latched version (1 cycle delayed) used for externally driven $\overline{D_TEA}$ and $\overline{D_TA}$.

Figure 30-33 shows an example of the termination signals protocol for back-to-back reads to two different slave devices who properly “take turns” driving the termination signals. This assumes a system using slave devices that drive termination signals.

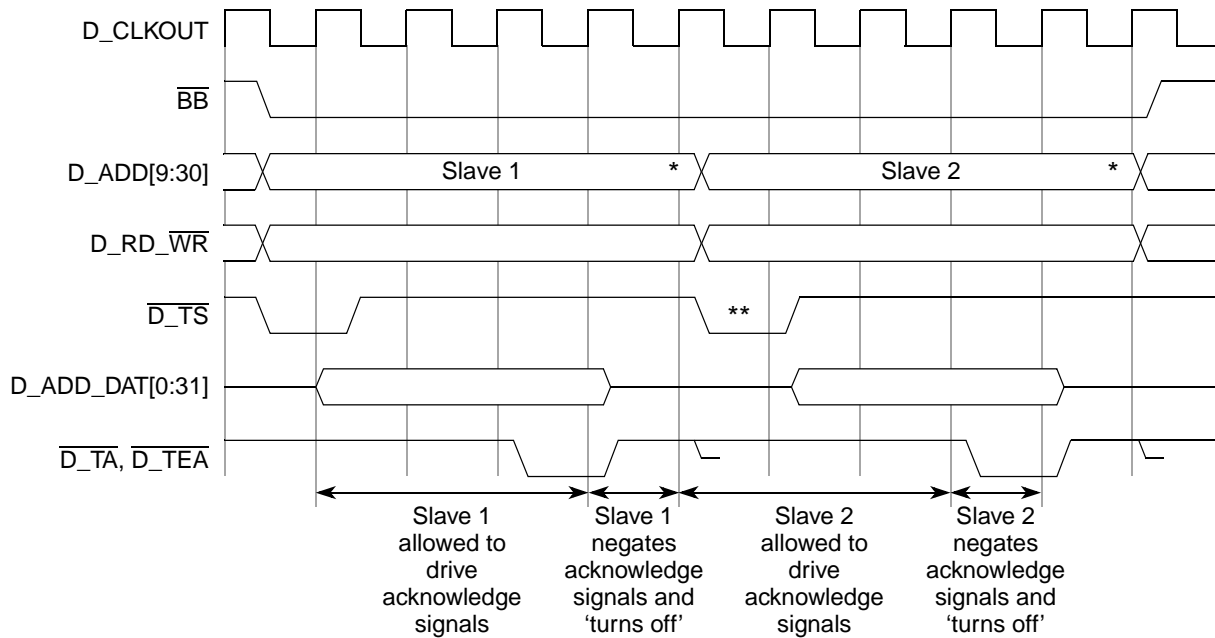

- * The EBI drives address and control signals an extra cycle because it uses a latched version of $\overline{D_TA}$ (1 cycle delayed) to terminate the cycle. An external master is not required to do this.
- ** This is the earliest that the EBI can start another transfer, in the case of continuing a set of small accesses. For all other cases, an extra cycle is needed before the EBI can start another $\overline{D_TS}$.

Figure 30-33. Termination Signals Protocol Timing Diagram

30.4.2.9 Non-Chip-Select Burst in 16-bit Data Bus Mode

The timing diagrams in this section apply only to the special case of a non-chip-select 32-bit access in 16-bit data bus mode (DBM=1 in EBI_MCR).

For this case, a special 2-beat burst protocol is used for reads and writes, so that a slave device (using the same EBI) can internally generate one 32-bit read or write access (thus 32-bit coherent), as opposed to two separate 16-bit accesses.

NOTE

Since this device does not support multi-master systems, the original intent of this protocol does not apply. However, this 2-beat burst protocol can also occur in a single-master system, if a non-chip-select 32-bit access to a 16-bit port is performed.

Figure 30-34 shows a 32-bit non-chip-select read from an external master in 16-bit data bus mode.

Figure 30-35 shows a 32-bit non-chip-select write from an external master in 16-bit data bus mode.

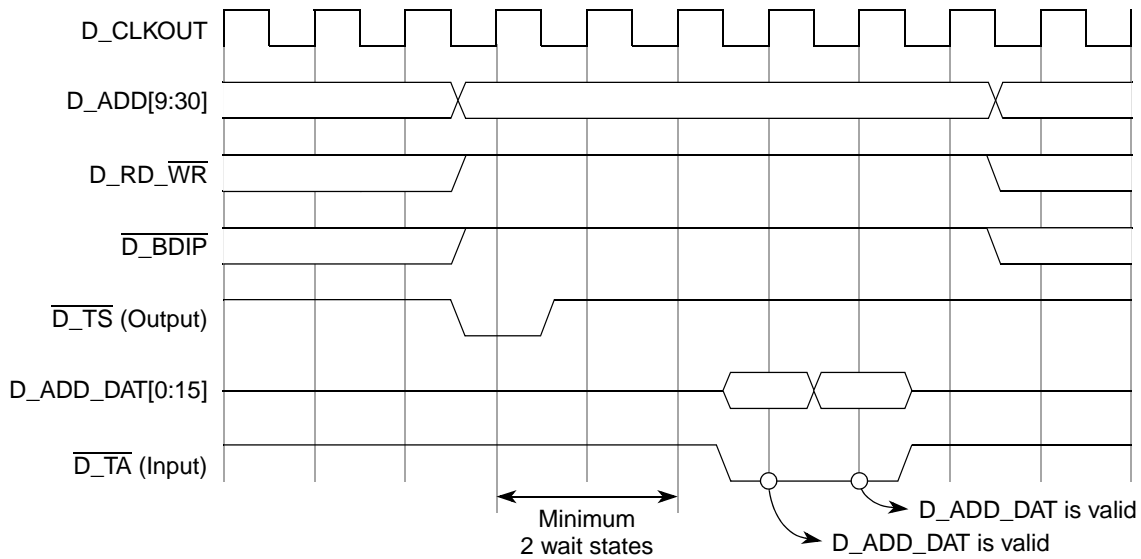

Figure 30-34. 32-bit non-Chip-Select Read from MCU with DBM=1

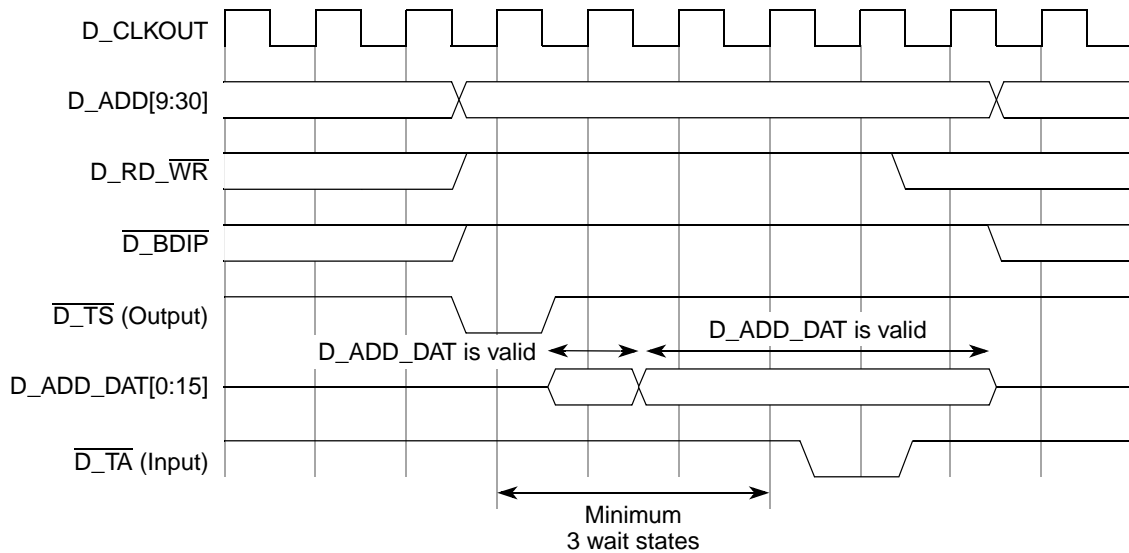

Figure 30-35. 32-bit non-Chip-Select Write to MCU with DBM=1

30.4.2.10 Calibration Bus Operation

Some devices with this EBI have a second external bus, intended for calibration use. This bus consists of a second set of the same signals present on the Primary external bus, except that arbitration, (and optionally other signals also) are excluded. Both busses can be supported with one EBI block, by using the calibration chip-selects to steer accesses to the calibration bus instead of the primary external bus.

Since the calibration bus has no arbitration signals, the arbitration on the primary bus controls accesses on the calibration bus as well, and no external master accesses can be performed on the calibration bus. Accesses cannot be performed in parallel on both external busses. However, back-to-back accesses can switch from one bus to the other, as determined by the type of chip-select each address matches.

The timing diagrams and protocol for the calibration bus is identical to the primary bus, except that some signals are missing on the calibration bus.

There is an inherent dead cycle between a calibration chip-select access and a non-calibration access (chip-select or non-chip-select), just like the one between accesses to two different non-calibration chip-selects (described in [Section 30.4.2.4.3, Back-to-Back Accesses](#)).

[Figure 30-36](#) shows an example of a non-calibration chip-select read access followed by a calibration chip-select read access. Note that this figure is identical to [Figure 30-18](#), except the CSy is replaced by CAL_CSy. Timing for other cases on calibration bus can similarly be derived from other figures in this document (by replacing CS with CAL_CS).

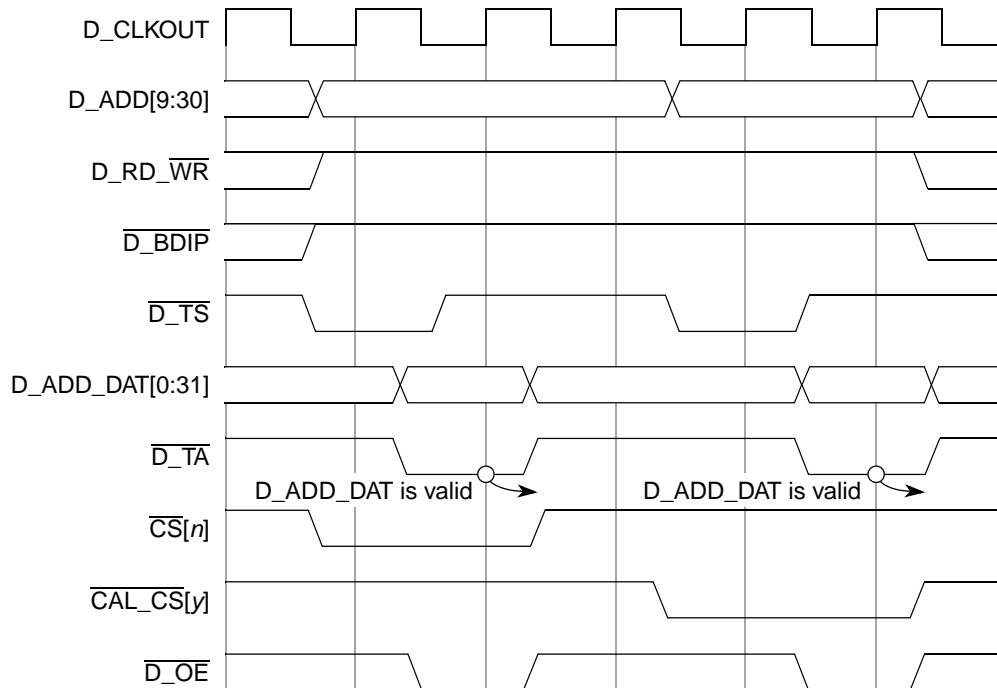

Figure 30-36. Back-to-Back 32-bit Reads to CS, CAL_CS Banks

30.4.2.11 Misaligned Access Support

This section describes all the misaligned cases supported by the EBI. These cases are a subset of the full set of cases allowed by the AMBA AHB V6 specification. The EBI works under the assumption that all internal masters on the device do not produce any misaligned access cases (to the EBI) other than the ones below.

30.4.2.11.1 Misaligned Access Support (64 bit AMBA)

[Table 30-20](#) shows all the misaligned access cases supported by the EBI (using a 64-bit AMBA implementation), as seen on the internal master AMBA bus. All other misaligned cases are not supported. If an unsupported misaligned access to the EBI is attempted (such as non-chip-select or burst misaligned

access), the EBI errors the access on the internal bus and does not start the access (nor assert $\overline{D_TEA}$) externally.

Table 30-20. Misalignment Cases Supported by a 64 bit AMBA EBI (internal bus)

| No. ¹ | Program Size and byte offset | Address [29:31] ² | Data Bus Byte Strobes ³ | HSIZE ⁴ | HUNALIGN ⁵ |
|------------------|--|------------------------------|------------------------------------|-----------------------|-----------------------|
| 1 | Half @0x1,0x9 | 001 | 0110_0000 | 10 | 1 |
| 2 | Half @0x3,0xB | 011 | 0001_1000 | 11 | 1 |
| 3 | Half @0x5,0xD | 101 | 0000_0110 | 10 | 1 |
| 4 | Half @0x7, 0xF (2 AHB transfers) | 111 000 | 0000_0001 1000_0000 | 01 ⁶ 00 | 1 0 |
| 5 | Word @0x1,0x9 | 001 | 0111_1000 | 11 | 1 |
| 6 | Word @0x2,0xA | 010 | 0011_1100 | 11 | 1 |
| 7 | Word @0x3,0xB | 011 | 0001_1110 | 11 | 1 |
| 8 | Word @0x5,0xD (2 AHB transfers) | 101 000 | 0000_0111 1000_0000 | 10 00 | 1 0 |
| 9 | Word @0x6, 0xE (2 AHB transfers) | 110 000 | 0000_0011 1100_0000 | 10 ⁷ 01 | 1 0 |
| 10 | Word @0x7,0xF (2 AHB transfers) | 111 000 | 0000_0001 1110_0000 | 10 ⁶ 10 | 1 1 |
| 12 | Doubleword @0x4,0x8 (2 AHB transfers) | 100 000 | 0000_1111 1111_0000 | 11 ⁸ 10 | 1 0 |
| 13 | Doubleword @0x2,0xA (2 AHB transfers) | 010 000 | 0011_1111 1100_0000 | 11 01 | 1 0 |
| 14 | Doubleword 0x6,0xE (2 AHB transfers) | 110 000 | 0000_0011 1111_1100 | 11 ⁷ 11 | 1 1 |

¹ Misaligned case number. Only transfers where HUNALIGN=1 are numbered as misaligned cases.

² Address on internal master AHB bus, not necessarily address on external D_ADD pins.

³ Internal byte strobe signals on AHB bus. Shown with Big-Endian byte ordering in this table, even though internal master AHB bus uses Little-Endian byte-ordering (EBI flips order internally).

⁴ Internal signal on AHB bus; 00=8-bits, 01=16 bits, 10=32 bits, 11=64-bits. HSIZE is driven according to the smallest aligned container that contains all the requested bytes. This results in extra EBI external transfers in some cases.

⁵ Internal signal on AHB bus that indicates that this transfer is misaligned (when 1).

⁶ For this case, the EBI internally treats HSIZE as 00 (1-byte access).

⁷ For this case, the EBI internally treats HSIZE as 01 (2-byte access).

⁸ For this case, the EBI internally treats HSIZE as 10 (4-byte access).

Table 30-21 shows which external transfers are generated by the EBI for the misaligned access cases in Table 30-20, for each port size.

The number of external transfers for each internal AHB master request is determined by the HSIZE value for that request relative to the port size. For example, a half-word write to @011 (misaligned case #2) with 16-bit port size results in 4 external 16-bit transfers because the HSIZE is 64-bits. For cases where two or more external transfers are required for one internal transfer request, these external accesses are considered part of a “small access” set, as described in Section 30.4.2.6, Small Accesses (Small Port Size and Short Burst Length).

Since all transfers are aligned on the external bus, normal timing diagrams and protocol apply.

Table 30-21. Misalignment Cases Supported by a 64 bit AMBA EBI (external bus)

| No. ¹ | PS ² | Program Size and byte offset | D_ADD[29:31] ³ | $\overline{D_WE}$ [0:3] ⁴ |
|------------------|-----------------|------------------------------------|---------------------------|---------------------------------------|
| 1 | 0 | Half @0x1,0x9 | 000 | 1001 |
| | 1 | | 000 010 | 1011 0111 |
| 2 | 0 | Half @0x3,0xB | 000 100 | 1110 0111 |
| | 1 | | 010 100 | 1011 0111 |
| 3 | 0 | Half @0x5,0xD | 100 | 1001 |
| | 1 | | 100 110 | 1011 0111 |
| 4 | 0 | Half @0x7,0xF (2 AHB transfers) | 111 ⁵ | 1110 |
| - | | | 000 | 0111 |
| 4 | | | 110 | 1011 |
| - | 1 | 000 | 0111 | |
| 5 | 0 | Word @0x1,0x9 | 000 100 | 1000 0111 |
| | 1 | | 000 010 100 | 1011 0011 0111 |
| 6 | 0 | Word @0x2,0xA | 000 100 | 1100 0011 |
| | 1 | | 010 100 | 0011 0011 |
| 7 | 0 | Word @0x3,0xB | 000 100 | 1110 0001 |
| | 1 | | 010 100 110 | 1011 0011 0111 |
| 8 | 0 | Word @0x5,0xD (2 AHB transfers) | 100 | 1000 |
| - | | | 000 | 0111 |
| 8 | | | 100 110 | 1011 0011 |
| - | 1 | 000 | 0111 | |
| 9 | 0 | Word @0x6,0xE (2 AHB transfers) | 110 ⁶ | 1100 |
| - | | | 000 | 0011 |
| 9 | | | 110 ⁶ | 0011 |
| - | 1 | 000 | 0011 | |

Table 30-21. Misalignment Cases Supported by a 64 bit AMBA EBI (external bus) (continued)

| No. ¹ | PS ² | Program Size and byte offset | D_ADD[29:31] ³ | $\overline{D_WE}$ [0:3] ⁴ | |
|------------------|-----------------|---|---|---------------------------------------|--------------|
| 10 | 0 | Word @0x7,0xF (2 AHB transfers) | 111 ⁵ | 1110 | |
| 11 | | | 000 | 0001 | |
| 10 | 1 | | 111 ⁵ | 1011 | |
| 11 | | | 000 010 | 0011 0111 | |
| 12 | 0 | | Doubleword @0x4,0xC (2 AHB transfers) | 100 ⁷ | 0000 |
| - | | | | 000 | 0000 |
| 12 | 1 | 100 ⁷ 110 | | 0011 0011 | |
| - | | 000 010 | | 0011 0011 | |
| 13 | 0 | Doubleword @0x2,0xA (2 AHB transfers) | | 000 100 | 1100 0000 |
| - | | | | 000 | 0011 |
| 13 | 1 | | 010 100 110 | 0011 0011 0011 | |
| - | | | 000 | 0011 | |
| 14 | 0 | | Doubleword @0x6,0xE (2 AHB transfers) | 110 ⁶ | 1100 |
| 15 | | | | 000 100 | 0000 0011 |
| 14 | 1 | 110 ⁶ | | 0011 | |
| 15 | | 000 010 100 | | 0011 0011 0011 | |

- ¹ Misaligned case number, from [Table 30-20](#).
- ² Port size; 0=32 bits, 1=16 bits.
- ³ External D_ADD pins, not necessarily the address on internal master AHB bus.
- ⁴ External $\overline{D_WE}$ pins. Note that these pins have negative polarity, opposite of the internal byte strobes in [Table 30-20](#).
- ⁵ Treated as 1-byte access.
- ⁶ Treated as 2-byte access.
- ⁷ Treated as 4-byte access.

30.4.2.12 Address Data Multiplexing

Address/Data multiplexing enables the design of a system with reduced pin count. In such a system, multiplexed address/data functions (on D_ADD_DAT pins) are used, instead of having separate address and data pins. Compared to the normal EBI specification (e.g. 24 address pins+32 data pins), only 32 data

pins are required (e.g. D_ADD_DAT[0:15] and D_ADD_DAT[16:31]). Compared to a 16-bit bus implementation, only 24 pins are required (e.g. D_ADD[8:15] + D_ADD_DAT[16:31]).

When performing a small access read, as described in [Section 30.4.2.6, Small Accesses \(Small Port Size and Short Burst Length\)](#), with A/D multiplexing enabled for this access, the EBI inserts an idle clock cycle with $\overline{D_OE}$ negated and \overline{CS} asserted, to allow for the memory to three-state the bus prior to the EBI driving the address on the next clock. This clock gap already exists (for other reasons) for non-small-access transfers, so no additional clock gap is inserted for those cases. See [Figure 30-37](#) for an example of a small access read with A/D multiplexing enabled.

In general, timing diagrams in A/D multiplexing mode are very similar to other diagrams in this document, except for the behavior of the D_ADD and D_ADD_DAT busses, which can be seen in [Figure 30-37](#).

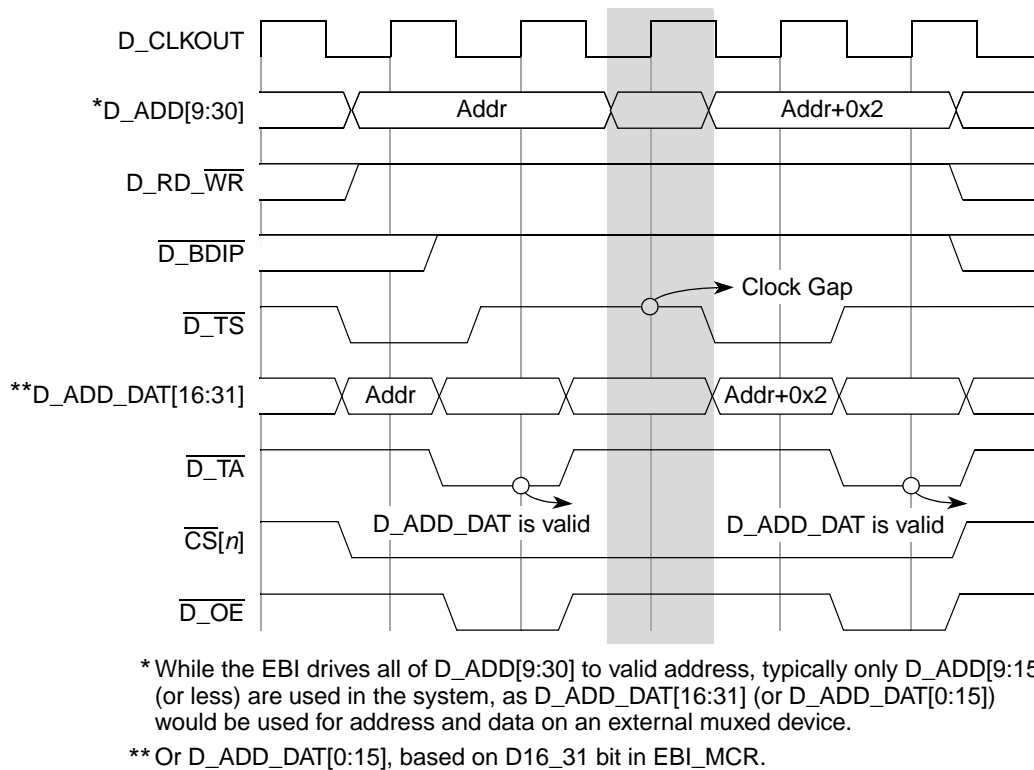

Figure 30-37. Small access (32-bit read to 16-bit port) on Address/Data multiplexed bus

30.5 Initialization/Application Information

30.5.1 Booting from External Memory

The EBI block does not support booting directly to external memory (i.e. fetching the first instruction after reset externally). One common method for an MCU to resemble an external boot with this EBI is to use an internal Boot Assist Module on the MCU, which fetches the first instruction internally and configures EBI registers before branching to an external address to “boot” externally.

If code in external memory needs to write EBI registers, this must be done in a way that avoids modifying EBI registers while external accesses are being performed, such as the following method:

- Copy the code that is doing the register writes (plus a return branch) to internal SRAM
- Branch to internal SRAM to run this code, ending with a branch back to external flash

30.5.2 Running with SDR (Single Data Rate) Burst Memories

This includes FLASH and SRAM memories with a compatible burst interface. $\overline{D_BDIP}$ is required only for some SDR memories. Figure 30-38 shows a block diagram of an MCU connected to a 32-bit SDR burst memory.

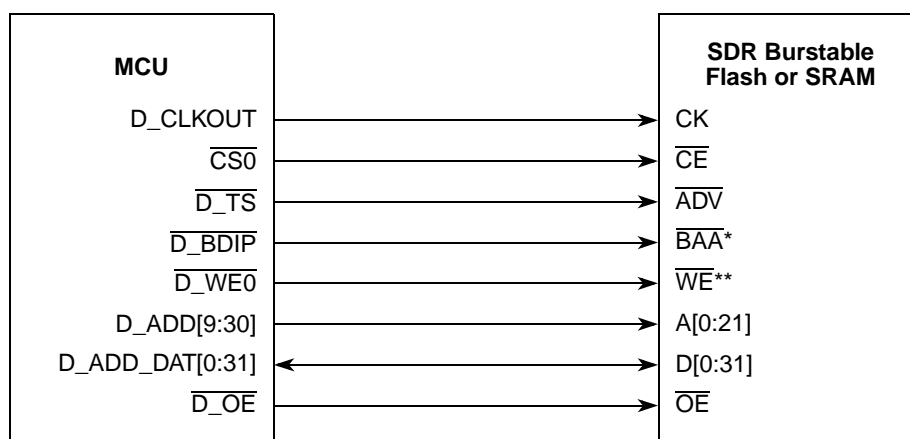

* May or may not be connected, depending on the memory used.
 ** Flash memories typically use one \overline{WE} signal as shown, RAMs use 2 or 4 (16-bit or 32-bit).

Figure 30-38. MCU Connected to SDR Burst Memory

Refer to Figure 30-23 for an example of the timing of a typical Burst Read operation to an SDR burst memory. Refer to Figure 30-14 for an example of the timing of a typical Single Write operation to SDR memory.

30.5.3 Running with Asynchronous Memories

The EBI also supports asynchronous memories. In this case, the D_CLKOUT , $\overline{D_TS}$, and $\overline{D_BDIP}$ pins are not used by the memory and bursting is not supported. However, the EBI still drives these outputs, and always drives and latches all signals at posedge D_CLKOUT (i.e., there is no “asynchronous mode” for the EBI). The data timing is controlled by setting the SCY bits in the appropriate Option Register to the proper number of wait states to work with the access time of the asynchronous memory, just as done for a synchronous memory.

30.5.3.1 Example Wait State Calculation

This example applies to any chip-select memory, synchronous or asynchronous.

As an example, say we have a memory with 50ns access time, and we are running the external bus @ 66 MHz (D_CLKOUT period: 15.2ns). Assume the input data spec for the MCU is 4ns.

$$\text{number of wait states} = (\text{access time}) / (D_CLKOUT \text{ period}) + (0 \text{ or } 1) \text{ (depending on setup time)}$$

$50/15.2 = 3$ with 4.4ns remaining (so we need at least 3 wait states, now check setup time)

$15.2 - 4.4 = 10.8\text{ns}$ (this is the achieved input data setup time)

Since actual input setup (10.8ns) is greater than the input setup spec (4.0ns), 3 wait states is sufficient. If the actual input setup was less than 4.0ns, we would have to use 4 wait states instead.

30.5.3.2 Timing and Connections for Asynchronous Memories

The connections to an asynchronous memory are the same as for a synchronous memory, except that the $\overline{D_CLKOUT}$, $\overline{D_TS}$, and $\overline{D_BDIP}$ signals are not used. Figure 30-39 shows a block diagram of an MCU connected to an asynchronous memory.

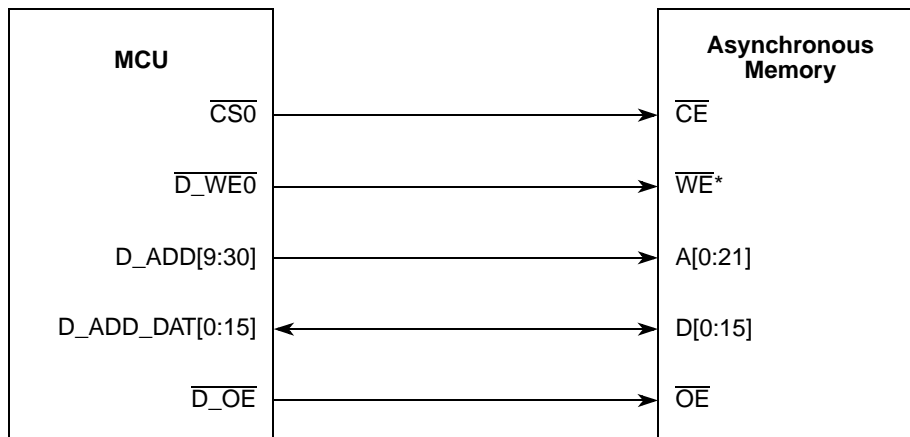

* Flash memories typically use one \overline{WE} signal as shown, RAMs use 2 or 4 (16-bit or 32-bit).

Figure 30-39. MCU Connected to Asynchronous Memory

Figure 30-40 shows a timing diagram of a read operation to a 16-bit asynchronous memory using 3 wait states.

Figure 30-41 shows a timing diagram of a write operation to a 16-bit asynchronous memory using 3 wait states.

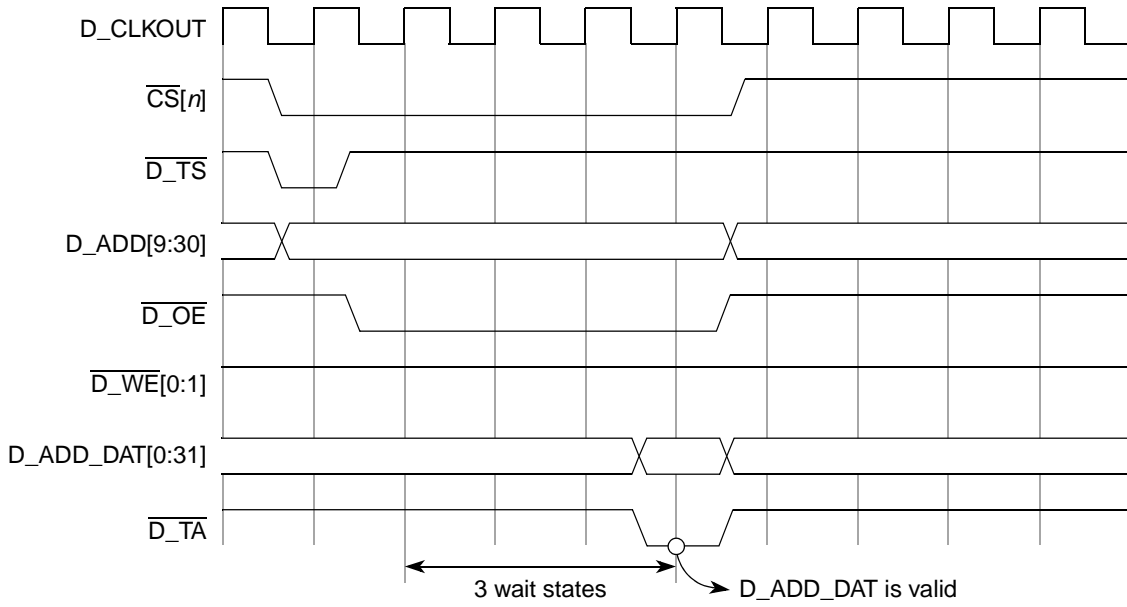

Figure 30-40. Read Operation to Asynchronous Memory, Three Initial Wait States

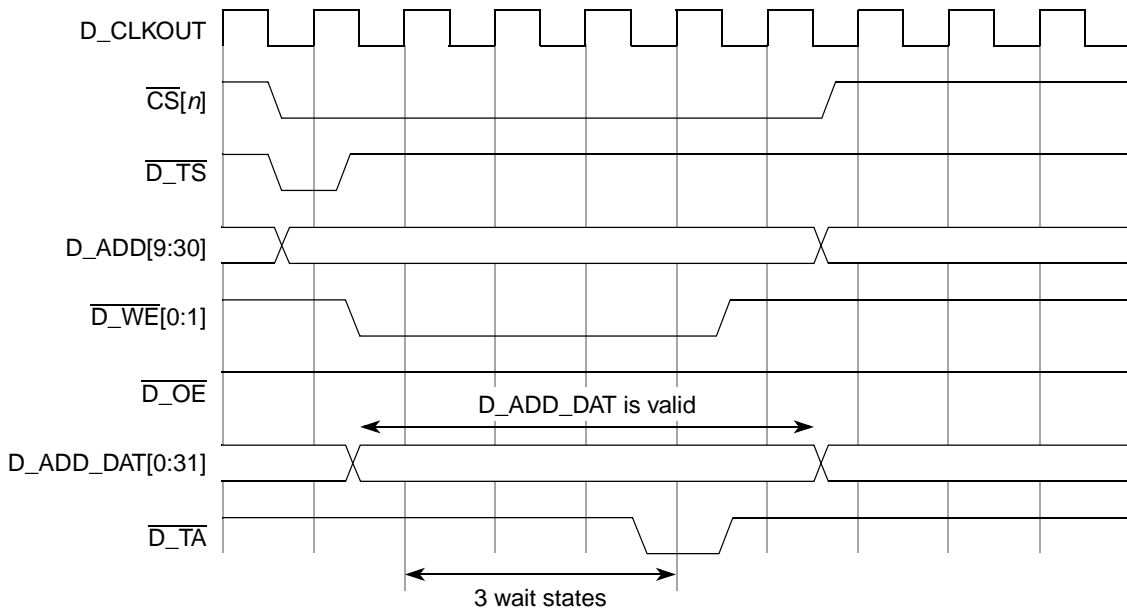
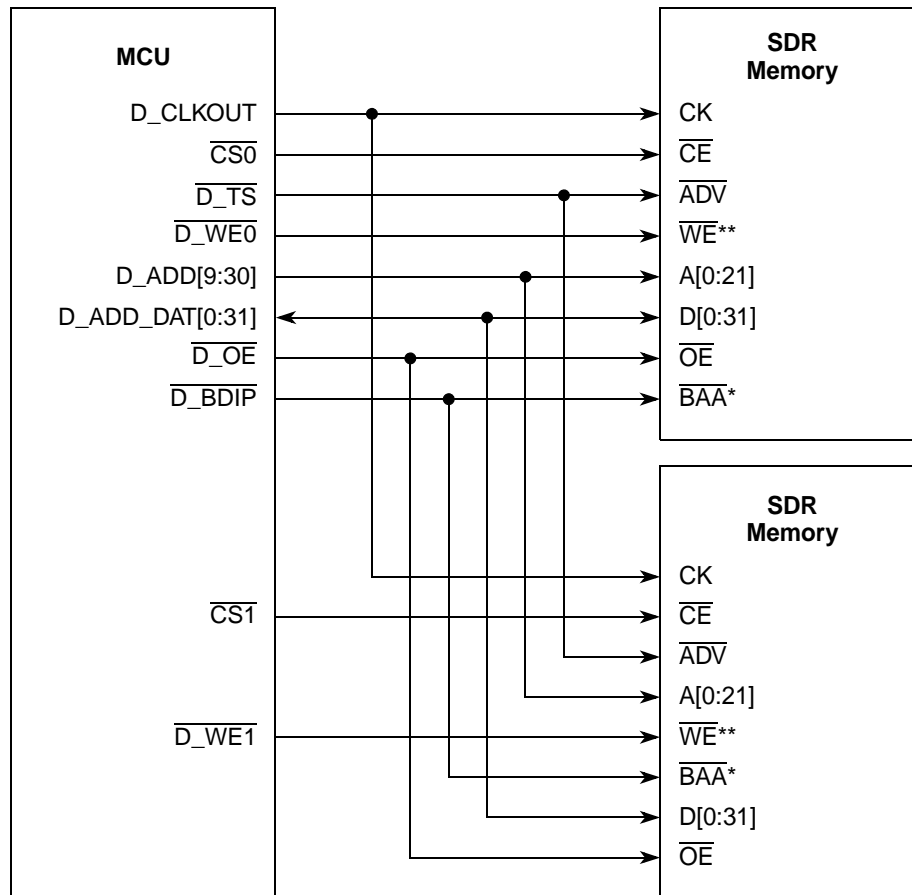

Figure 30-41. Write Operation to Asynchronous Memory, Three Initial Wait States

30.5.4 Connecting an MCU to Multiple Memories

The MCU can be connected to more than one memory at a time.

Figure 30-42 shows an example of how two memories could be connected to one MCU.



* May or may not be connected, depending on the memory used.

** Flash memories typically use one WE signal as shown, RAMs use 2 or 4 (16-bit or 32-bit).

Figure 30-42. MCU Connected to Multiple Memories

30.5.5 Summary of Differences from MPC5xx

Below is a summary list of the significant differences between this EBI and that of the MPC5xx parts.

- No memory controller support for external masters
 - must configure each master in multi-master system to drive its own chip selects
 - rationale: save complexity, no requirement for this feature
- Burst mechanism updated to be compatible with e200z core with 32-byte cache line
 - rationale: required for performance and compatibility with e200z core
- Removed these variable timing attributes from Option Register:
 - CSNT, ACS, TRLX, EHTR
 - rationale: reduces tester edgesets and complexity, no clear requirements for these features
- Removed reservation support on external bus
 - rationale: reservation not supported on internal bus, useless to support on external
- Removed Address Type (AT), Write-Protect (WP), and dual-mapping features

- rationale: these functions can be replicated by Memory Management Unit (MMU) in e200z core
- Removed support for 8-bit ports
 - rationale: reduces complexity and not required
- Removed boot chip-select operation
 - rationale: on-chip Boot Assist Module (BAM) handles boot (and configuration of EBI registers)
- Open drain mode and pullup resistors no longer required for multi-master systems, extra cycle needed to switch between masters
 - rationale: saves customer hassle for multi-master system setup, at negligible performance cost
- Address decoding for external master accesses uses 4-bit code to determine internal slave instead of straight address decode
 - rationale: needed for compatibility with internal bridge address decoding and memory map
- Removed support for 3-master systems
 - rationale: very difficult to manage with internal bridge address decoding method and keep memory maps unique; not an essential feature to justify complexity of supporting
- Removed LBDIP Base Register bit, now late $\overline{D_BDIP}$ assertion is default behavior
 - rationale: unaware of any memories that require $\overline{D_BDIP}$ to assert earlier than LBDIP timing, so reduce number of CS control bits and complexity
- Modified arbitration protocol to require extra cycles when switching between masters
 - rationale: could not use exact Oak protocol and make timing for full-speed operation; adding dead cycles to protocol allows bus to run full-speed in external master mode and makes this feature not limit overall EBI frequency
- Added support for 32-bit coherent read & write non-chip-select accesses in 16-bit data bus mode
 - rationale: some internal registers must be accessed all 32 bits at once to function as expected
- Added misaligned access support
 - rationale: some eSys cores require use of misaligned accesses for optimum performance
- Added calibration access support
 - rationale: support related device logic added to multiple eSys devices's, requested customer feature
- Added support for larger external address bus (up to 29 bits)
 - rationale: support larger external memory sizes
- Added support for address/data multiplexing
 - rationale: new feature to reduce minimum pin count
- Added support for using either half of data bus for 16-bit port transfers
 - rationale: helps A/D muxed usability, while maintaining backwards compatibility

Chapter 31

Nexus Development Interface (NDI)

31.1 Introduction

The device microcontroller contains multiple Nexus clients that communicate over a single IEEE®-ISTO 5001™-2003 Nexus class 3 combined JTAG IEEE 1149.1/auxiliary out interface. Combined, all of the Nexus clients are referred to as the Nexus development interface (NDI). Class 3 Nexus allows for program, data, and ownership trace of the microcontroller execution without access to the external data and address buses.

This chapter is organized into sections that provide a high level view of the Nexus development interface: [Section 31.1, Introduction](#), through [Section 31.8, NPC Initialization and Application Information](#).

The chapter contains sections that discuss the modules of the Nexus development interface:

- Nexus dual-eTPU development interface (NDEDI). The device has two eTPU engines. See [Section 31.9, Nexus Dual eTPU Development Interface \(NDEDI\)](#), and the *eTPU Reference Manual* for information about the NDEDI.
- Nexus e200z7 core interface (NZ7C3). In this chapter, the NZ7C3 interface is discussed in [Section 31.10, e200z7 Class 3 Nexus Module \(NZ7C3\)](#) through [Section 31.11, NZ7C3 Memory Map and Register Definition](#).
- Nexus crossbar eDMA interface (NXDM) and Nexus FlexRay interface (NXFR). Refer to [Section 31.15, Nexus Crossbar eDMA Interface \(NXDM\) and Nexus Crossbar FlexRay Interface \(NXFR\)](#).

Communication to the NDI is managed via the auxiliary port and the JTAG port.

- The auxiliary port is comprised of 17 or 21 output pins and 1 input pin. The output pins include one message clock out (MCKO) pin, 12 or 16 message data out (MDO) pins, two message start/end out (MSEO) pins, one ready (RDY) pin, and one event out (EVTO) pin. Event in (EVTI) is the only input pin for the auxiliary port.
- The JTAG port consists of four inputs and one output. These pins include JTAG compliance select (JCOMP), test data input (TDI), test data output (TDO), test mode select (TMS), and test clock input (TCK). TDI, TDO, TMS, and TCK are compliant with the IEEE 1149.1-2001 standard and are shared with the NDI through the test access port (TAP) interface. JCOMP along with power-on reset and the TAP state machine are used to control reset for the NDI module. Ownership of the TAP is achieved by loading the appropriate enable instruction for the desired Nexus client in the JTAG controller (JTAGC) when JCOMP is asserted. See [Table 31-4](#) for the JTAGC opcodes to access the different Nexus clients.

31.1.1 Block Diagram

Figure 31-1 shows a general block diagram of the NDI components

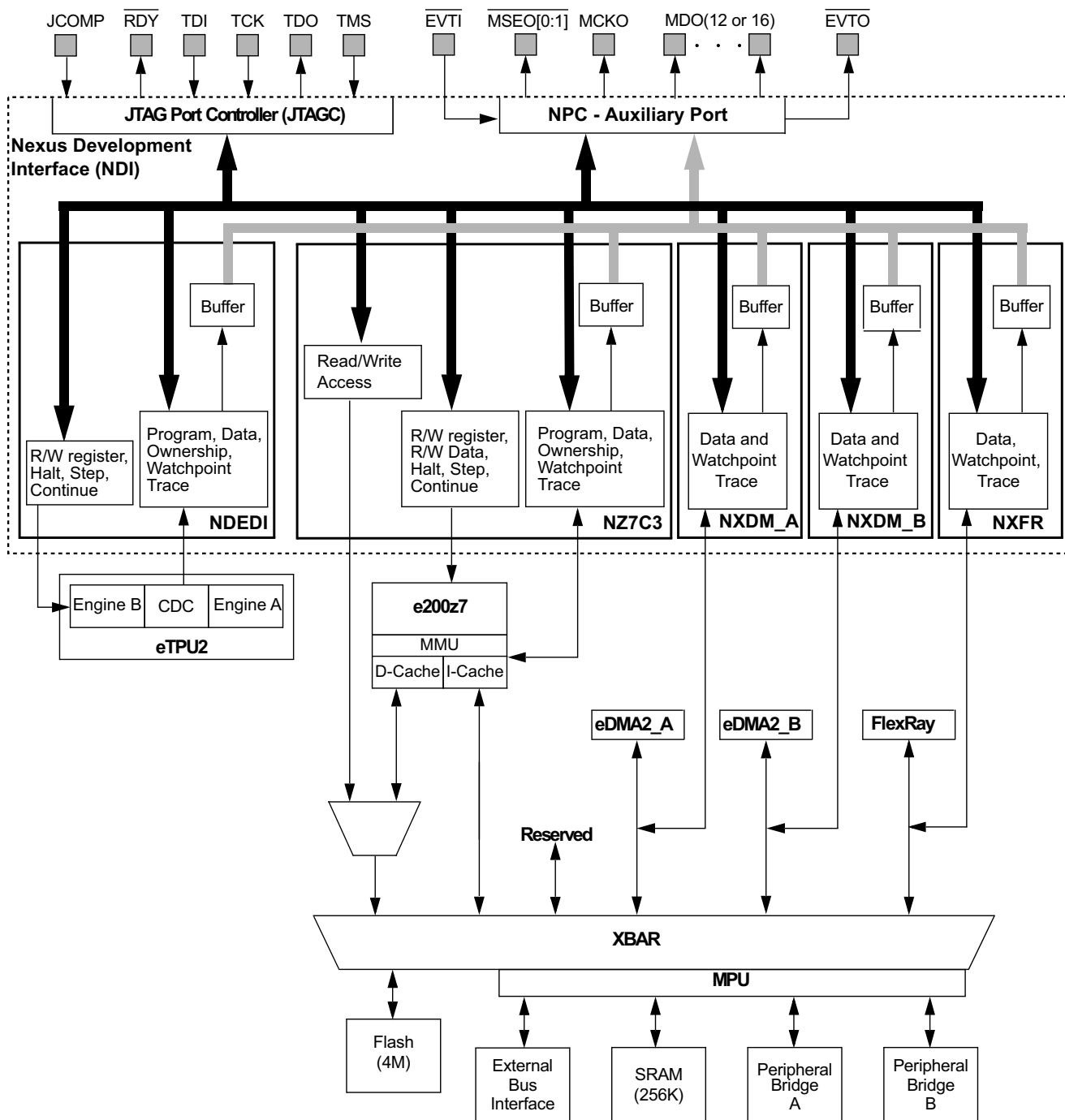

Figure 31-1. NDI General Block Diagram

31.1.2 Features

The NDI module is compliant with the IEEE-ISTO 5001-2011. The following features are implemented:

- Full duplex pin interface for medium and high visibility throughput
 - One of two modes selected by register configuration: full port mode (FPM) and reduced port mode (RPM). FPM comprises 16 MDO pins, and RPM comprises 12 MDO pins.
 - Auxiliary output port
 - One MCKO (message clock out) pin
 - 16 MDO (message data out) pins
 - Two $\overline{\text{MSEO}}$ (message start/end out) pins
 - One $\overline{\text{RDY}}$ (ready) pin
 - One $\overline{\text{EVTO}}$ (event out) pin
 - Auxiliary input port uses one $\overline{\text{EVTI}}$ (event in) pin
 - Five-pin JTAG port (JCOMP, TDI, TDO, TMS, and TCK)
- Host processor (e200z7) development support features (NZ7C3)
 - IEEE-ISTO 5001-2011 class 3 compliant.
 - Data trace via data write messaging (DWM) and data read messaging (DRM). This allows the development tool to trace reads and/or writes to selected internal memory resources.
 - Ownership trace via ownership trace messaging (OTM). OTM facilitates ownership trace by providing visibility of which process ID or operating system task is activated. An ownership trace message is transmitted when a new process/task is activated, allowing development tools to trace ownership flow.
 - Program trace via branch trace messaging (BTM). Branch trace messaging displays program flow discontinuities (direct branches, indirect branches, exceptions, etc.), allowing the development tool to interpolate what transpires between the discontinuities. Thus, static code can be traced.
 - Watchpoint messaging (WPM) via the auxiliary port.
 - Watchpoint trigger enable of program and/or data trace messaging.
 - Data tracing of instruction fetches via private opcodes.
 - Subset of Power Architecture Book E software debug facilities with OnCE block (Nexus class 1 features).
- Two eDMA development support features (NXDM)
 - Data trace via data write messaging (DWM) and data read messaging (DRM). This allows the development tool to trace DMA generated reads and/or writes to selected address ranges in the device's memory map.
 - Watchpoint messaging (WPM) via the auxiliary port.
 - Watchpoint trigger enable/disable of data trace messaging.
- FlexRay development support features (NXFR)

- FlexRay Nexus trace via data write messaging (DWM) and data read messaging (DRM). This allows the development tool to trace FlexRay generated reads and/or writes to selected address ranges in the device's memory map.
- Watchpoint messaging (WPM) via the auxiliary port.
- Watchpoint trigger enable/disable of data trace messaging.
- eTPU development support features (NDEDI)
 - IEEE-ISTO 5001-2002 standard Class 3 compliant for the eTPU engines.
 - Data trace via data write messaging and data read messaging. This allows the development tool to trace reads and writes to selected shared parameter RAM (SPRAM) address ranges. Four data trace windows are shared by the two eTPU engines.
 - Ownership trace via ownership trace messaging (OTM). OTM facilitates ownership trace by providing visibility of which channel is being serviced. An ownership trace message is transmitted to indicate when a new channel service request is scheduled, allowing the development tools to trace task flow. A special OTM is sent when the engine enters in idle state, meaning that all requests were serviced and no new requests are yet scheduled.
 - Program trace via branch trace messaging. BTM displays program flow discontinuities (start, jumps, return, etc.), allowing the development tool to interpolate what transpires between the discontinuities. Thus static code can be traced. The branch trace messaging method uses the branch/predicate method to reduce the number of generated messages.
 - Watchpoint messaging via the auxiliary port. WPM provides visibility of the occurrence of the eTPU's' watchpoints and breakpoints.
 - Nexus based breakpoint/watchpoint configuration and single step support.
- Run-time access to the on-chip memory map via the Nexus read/write access protocol. This feature supports accesses for run-time internal visibility, calibration variable acquisition, calibration constant tuning, and external rapid prototyping for powertrain automotive development systems.
- All features are independently configurable and controllable via the IEEE 1149.1 I/O port.
- The NDI block reset is controlled with JCOMP, power-on reset, and the TAP state machine. These sources are independent of system reset.

31.1.3 Modes of Operation

The NDI block is in reset when the TAP controller state machine is in the TEST-LOGIC-RESET state. The TEST-LOGIC-RESET state is entered on the assertion of the power-on reset signal, negation of JCOMP, or through state machine transitions controlled by TMS. Assertion of JCOMP allows the NDI to move out of the reset state, and is a prerequisite to grant Nexus clients control of the TAP. Ownership of the TAP is achieved by loading the appropriate enable instruction for the desired Nexus client in the JTAGC controller (JTAGC) block when JCOMP is asserted.

Following negation of power-on reset, the NPC remains in reset until the system clock achieves lock. In PLL bypass mode, the NDI can transition out of the reset state immediately following negation of power-on reset. See [Section 31.5, Nexus Port Controller \(NPC\)](#), for more details.

31.1.3.1 Nexus Reset Mode

In Nexus reset mode, the following actions occur:

- Register values default back to their reset values.
- The message queues are marked as empty.
- The auxiliary output port pins are negated if the NDI controls the pads.
- The TDO output buffer is disabled if the NDI has control of the TAP.
- The TDI, TMS, and TCK inputs are ignored.
- The NDI block indicates to the MCU that it is not using the auxiliary output port. This indication can be used to three-state the output pins or use them for another function.

31.1.3.2 Full-Port Mode

In full-port mode, all the available MDO pins are used to transmit messages. All trace features are enabled or can be enabled by writing the configuration registers via the JTAG port. The number of MDO pins available is 16.

31.1.3.3 Reduced-Port Mode

In reduced-port mode, a subset of the available MDO pins are used to transmit messages. All trace features are enabled or can be enabled by writing the configuration registers via the JTAG port. The number of MDO pins available is 12. Unused MDO pins can be used as GPIO. Details on GPIO functionality configuration can be found in [Section 7.3.1.13, Pad Configuration Registers \(SIU_PCR\)](#).

31.1.3.4 Disabled-Port Mode

In disabled-port mode, message transmission is disabled. Any debug feature that generates messages can not be used. The primary features available are class 1 features and read/write access.

31.1.3.5 Censored Mode

When the device is in censored mode, reading the contents of internal flash externally is not allowed. To prevent Nexus modules from violating censorship, the NPC is held in reset when in censored mode, asynchronously holding all other Nexus modules in reset as well. This prevents Nexus read/write to memory mapped resources and the transmission of Nexus trace messages. See [Chapter 12, Flash Memory Array and Control](#), for information on Nexus port enabling and disabling regarding censorship.

31.2 External Signal Description

The auxiliary and JTAG pin interfaces provide for the transmission of messages from Nexus modules to the external development tools and for access to Nexus client registers. The auxiliary/JTAG pin definitions are outlined in [Table 31-1](#).

Table 31-1. Signal Properties

| Signal Name | Port | Function | Reset State |
|-------------------------------|-----------|---|-----------------|
| $\overline{\text{EVTO}}$ | Auxiliary | Event out pin | Negated |
| $\overline{\text{EVTI}}$ | Auxiliary | Event in pin | Pullup |
| MCKO | Auxiliary | Message clock out pin (from NPC) | Enabled |
| MDO[11:0] or MDO[15:0] | Auxiliary | Message data out pins | Driven Low |
| $\overline{\text{MSEO}}[1:0]$ | Auxiliary | Message start/end out pins | Negated |
| $\overline{\text{RDY}}$ | Auxiliary | Ready out pin | Negated |
| JCOMP | JTAG | JTAG compliancy and TAP sharing control | Pulldown |
| TCK | JTAG | Test clock input | Pulldown |
| TDI | JTAG | Test data input | Pullup |
| TDO | JTAG | Test data output | High Z / Pullup |
| TMS | JTAG | Test mode select input | Pullup |

31.2.1 Detailed Signal Descriptions

This section describes each of the signals listed in [Table 31-1](#) in more detail.

31.2.1.1 Event Out ($\overline{\text{EVTO}}$)

$\overline{\text{EVTO}}$ is an output pin that is asserted upon breakpoint occurrence to provide breakpoint status indication or to signify that an event has occurred. The $\overline{\text{EVTO}}$ output of the NPC is generated based on the values of the individual $\overline{\text{EVTO}}$ signals from all Nexus modules that implement the signal.

31.2.1.2 Event In ($\overline{\text{EVTI}}$)

$\overline{\text{EVTI}}$ is used to initiate program and data trace synchronization messages or to generate a breakpoint. $\overline{\text{EVTI}}$ is edge-sensitive for synchronization and breakpoint generation.

31.2.1.3 Message Data Out (MDO[11:0] or [15:0])

Message data out (MDO) are output pins used for uploading OTM, BTM, DTM, and other messages to the development tool. The development tool must sample MDO on the rising edge of MCKO. The width of the MDO bus used is determined by the Nexus PCR[FPM] configuration.

31.2.1.4 Message Start/End Out ($\overline{\text{MSEO}}[1:0]$)

$\overline{\text{MSEO}}[1:0]$ are output pins that indicates when a message on the MDO pins has started, when a variable length packet has ended, or when the message has ended. The development tool must sample the $\overline{\text{MSEO}}$ pins on the rising edge of MCKO.

31.2.1.5 Ready ($\overline{\text{RDY}}$)

$\overline{\text{RDY}}$ is an output pin that indicates when a device is ready for the next access.

31.2.1.6 JTAG Compliancy (JCOMP)

The JCOMP signal enables or disables the TAP controller. The TAP controller is enabled when JCOMP asserts, otherwise the TAP controller remains in reset.

31.2.1.7 Test Data Output (TDO)

The TDO pin transmits serial output for instructions and data. TDO is tri-stateable and is actively driven in the SHIFT-IR and SHIFT-DR controller states. TDO is updated on the falling edge of TCK and sampled by the development tool on the rising edge of TCK.

31.2.1.8 Test Clock Input (TCK)

The TCK pin is used to synchronize the test logic and control register access through the JTAG port.

31.2.1.9 Test Data Input (TDI)

The TDI pin receives serial test instruction and data. TDI is sampled on the rising edge of TCK.

31.2.1.10 Test Mode Select (TMS)

The TMS pin is used to sequence the IEEE 1149.1-2001 TAP controller state machine. TMS is sampled on the rising edge of TCK.

31.3 Memory Map

The NDI block contains no memory mapped registers. Nexus registers are accessed by the development tool via the JTAG port using a register index and a client select value. The client select is controlled by loading the correct access instruction into the JTAG controller; see [Table 31-4](#). OnCE registers are accessed by loading the appropriate value in the RS[0:6] field of the OnCE command register (OCMD) via the JTAG port.

[Table 31-2](#) shows the NDI registers and their Index values.

Table 31-2. Nexus Development Interface (NDI) Registers

| Index | Register |
|--|---|
| NPC Registers | |
| 0 | Device ID Register (DID) |
| 127 | Port Configuration Register (PCR) |
| e200z7 Control and Status Registers¹ | |
| 2 | e200z7 Development Control1 (NZ7C3_DC1) |
| 3 | e200z7 Development Control2 (NZ7C3_DC2) |

Table 31-2. Nexus Development Interface (NDI) Registers (continued)

| Index | Register |
|--|--|
| 4 | e200z7 Development Control3 (NZ7C3_DC3) |
| 5 | e200z7 Development Control4 (NZ7C3_DC4) |
| 7 | Read/Write Access Control/Status (NZ7C3_RWCS) |
| 9 | Read/Write Access Address (NZ7C3_RWA) |
| 10 | Read/Write Access Data (NZ7C3_RWD) |
| 11 | e200z7 Watchpoint Trigger (NZ7C3_WT) |
| 13 | e200z7 Data Trace Control (NZ7C3_DTC) |
| 14 | e200z7 Data Trace Start Address 1 (NZ7C3_DTSA1) |
| 15 | e200z7 Data Trace Start Address 2 (NZ7C3_DTSA2) |
| 16 | e200z7 Data Trace Start Address 3 (NZ7C3_DTSA3) |
| 17 | e200z7 Data Trace Start Address 4 (NZ7C3_DTSA4) |
| 18 | e200z7 Data Trace End Address 1 (NZ7C3_DTEA1) |
| 19 | e200z7 Data Trace End Address 2 (NZ7C3_DTEA2) |
| 20 | e200z7 Data Trace End Address 3 (NZ7C3_DTEA3) |
| 21 | e200z7 Data Trace End Address 4 (NZ7C3_DTEA4) |
| 48 | Development Status (DS) |
| 50 | Overrun Control (OVCR) |
| 51 | Watchpoint Mask (WMSK) |
| 53 | Program Trace Start Trigger Control (PTSTC) |
| 54 | Program Trace End Trigger Control (PTETC) |
| 55 | Data Trace Start Trigger Control (DTSTC) |
| 56 | Data Trace End Trigger Control (DTETC) |
| eDMA_A/B Control and Status Registers | |
| 2 | eDMA_x Development Control (NXDM_DC) |
| 11 | eDMA_x Watchpoint Trigger (NXDM_WT) |
| 13 | eDMA_x Data Trace Control (NXDM_DTC) |
| 14 | eDMA_x Data Trace Start Address 0 (NXDM_DTSA1) |
| 15 | eDMA_x Data Trace Start Address 1 (NXDM_DTSA2) |
| 18 | eDMA_x Data Trace End Address 0 (NXDM_DTEA1) |
| 19 | eDMA_x Data Trace End Address 1 (NXDM_DTEA2) |
| 22 | eDMA_x Breakpoint and Watchpoint Control 1 (NXDM_BWC1) |
| 23 | eDMA_x Breakpoint and Watchpoint Control 2 (NXDM_BWC2) |
| 30 | eDMA_x Breakpoint and Watchpoint Address 1 (NXDM_BWA1) |

Table 31-2. Nexus Development Interface (NDI) Registers (continued)

| Index | Register |
|--|---|
| 31 | eDMA_x Breakpoint and Watchpoint Address 2 (NXDM_BWA2) |
| FlexRay Control and Status Registers | |
| 2 | FlexRay Development Control (NXFM_DC) |
| 11 | FlexRay Watchpoint Trigger (NXFM_WT) |
| 13 | FlexRay Data Trace Control (NXFM_DTC) |
| 14 | FlexRay Data Trace Start Address 0 (NXFM_DTSA1) |
| 15 | FlexRay Data Trace Start Address 1 (NXFM_DTSA2) |
| 18 | FlexRay Data Trace End Address 0 (NXFM_DTEA1) |
| 19 | FlexRay Data Trace End Address 1 (NXFM_DTEA2) |
| 22 | FlexRay Breakpoint and Watchpoint Control 1 (NXFM_BWC1) |
| 23 | FlexRay Breakpoint and Watchpoint Control 2 (NXFM_BWC2) |
| 30 | FlexRay Breakpoint and Watchpoint Address 1 (NXFM_BWA1) |
| 31 | FlexRay Breakpoint and Watchpoint Address 2 (NXFM_BWA2) |
| eTPU Engines Control/Status Registers | |
| 0 | Device ID (DID) |
| 1 | Client Select Control (CSC), eTPU Engine 1 / eTPU Engine 2 |
| 2 | eTPU2 Development Control (NDI_eTPU2_DC) |
| 4 | eTPU2 Development Status (NDEDI_eTPU2_DS) |
| 11 | eTPU2 Watchpoint Trigger (NDI_eTPU2_WT) |
| 13 | eTPU2 Data Trace Control (NDI_eTPU2_DTC) |
| 22 | eTPU2 Breakpoint/Watchpoint Control 1 (NDEDI_eTPU2_BWC1) |
| 23 | eTPU2 Breakpoint/Watchpoint Control 2 (NDEDI_eTPU2_BWC2) |
| 24 | eTPU2 Breakpoint/Watchpoint Control 3 (NDEDI_eTPU2_BWC3) |
| 30 | eTPU2 Breakpoint/Watchpoint Address 1 (NDEDI_eTPU2_BWA1) |
| 31 | eTPU2 Breakpoint/Watchpoint Address 2 (NDEDI_eTPU2_BWA2) |
| 38 | eTPU2 Breakpoint/Watchpoint Data 1 (NDEDI_eTPU2_BWD1) |
| 39 | eTPU2 Breakpoint/Watchpoint Data 1 (NDEDI_eTPU2_BWD2) |
| 64 | eTPU2 Program Trace Channel Enable (NDI_eTPU2_PTCE) |
| 69 | eTPU2 Microinstruction Debug Register (NDEDI_eTPU2_INST) |
| 70 | eTPU2 Microprogram Counter Debug Register (NDEDI_eTPU2_MPC) |
| 71 | eTPU2 Channel Flag Status Register (NDEDI_eTPU2_CFSR) |
| 127 | Port Configuration Register (PCR) |

¹ These e200z7 registers are described in the *e200z7 Core Reference Manual*.

Table 31-3 shows the OnCE register addressing.

Refer to the Debug Support section in the *z759n3 Core Reference Manual* for the description of the OnCE controller and its internal registers.

Table 31-3. e200z7 OnCE Register Addressing

| OCMD, RS[0:6] | Register Selected |
|-------------------|--|
| 000 0000–000 0001 | Invalid value |
| 000 0010 | JTAG DID (read-only) |
| 000 0011–000 1111 | Invalid value |
| 001 0000 | CPU Scan Register (CPUSCR) |
| 001 0001 | No Register Selected (Bypass) |
| 001 0010 | OnCE Control Register (OCR) |
| 001 0011–001 1111 | Invalid value |
| 010 0000 | Instruction Address Compare 1 (IAC1) |
| 010 0001 | Instruction Address Compare 2 (IAC2) |
| 010 0010 | Instruction Address Compare 3 (IAC3) |
| 010 0011 | Instruction Address Compare 4 (IAC4) |
| 010 0100 | Data Address Compare 1 (DAC1) |
| 010 0101 | Data Address Compare 2 (DAC2) |
| 010 0110 | Data Value Compare 1 (DVC1) |
| 010 0111 | Data Value Compare 2 (DVC2) |
| 010 1000 | Instruction Address Compare 5 (IAC5) |
| 010 1001 | Instruction Address Compare 6 (IAC6) |
| 010 1010 | Instruction Address Compare 7 (IAC7) |
| 010 1011 | Instruction Address Compare 8 (IAC8) |
| 010 1100 | Debug Counter Register (DBCNT) |
| 010 1101 | Debug PCFIFO (PCFIFO) (read-only) |
| 010 1110 | External Debug Control Register 0 (EDBCR0) |
| 010 1111 | External Debug Status Register 0 (EDBSR0) |
| 011 0000 | Debug Status Register (DBSR) |
| 011 0001 | Debug Control Register 0 (DBCR0) |
| 011 0010 | Debug control register 1 (DBCR1) |
| 011 0011 | Debug control register 2 (DBCR2) |
| 011 0100 | Debug control register 3 (DBCR3) |
| 011 0101 | Debug control register 4 (DBCR4) |
| 011 0110 | Debug control register 5 (DBCR5) |

Table 31-3. e200z7 OnCE Register Addressing (continued)

| OCMD, RS[0:6] | Register Selected |
|-------------------|--|
| 011 0111 | Debug control register 6 (DBCR6) |
| 011 1000–011 1100 | Invalid value (do not access) |
| 011 1101 | Debug Data Acquisition Message Register (DDAM) |
| 011 1110 | Debug Event Control (DEVENT) |
| 011 1111 | Debug External Resource Control (DBERC0) |
| 111 0000–111 1001 | General purpose register selects [0:9] |
| 111 1010 | Cache Debug Access Control Register (CDACNTL) |
| 111 1011 | Cache Debug Access Data Register (CDADATA) |
| 111 1100 | Nexus3-access |
| 111 1101 | LSRL select |
| 111 1110 | Enable_OnCE (and bypass) |
| 111 1111 | Bypass |

31.4 NDI Functional Description

31.4.1 Enabling Nexus Clients for TAP Access

After the NDI is out of the reset state, the loading of a specific instruction in the JTAG controller (JTAGC) block is required to grant the NDI ownership of the TAP. Each Nexus client has its own JTAGC instruction opcode for ownership of the TAP, granting that client the means to read/write its registers. The JTAGC instruction opcode for each Nexus client is shown in [Table 31-4](#). After the JTAGC opcode for a client has been loaded, the client is enabled by loading its NEXUS-ENABLE instruction. The NEXUS-ENABLE instruction opcode for each Nexus client is listed in [Table 31-5](#). Opcodes for all other instructions supported by Nexus clients can be found in the relevant sections of this chapter.

Table 31-4. JTAG Client Select Instructions

| JTAGC Instruction | Opcode | Description |
|-----------------------|--------|--|
| ACCESS_AUX_TAP_NPC | 10000 | Enables access to the NPC TAP controller |
| ACCESS_AUX_TAP_ONCE | 10001 | Enables access to the e200z7 OnCE TAP controller |
| ACCESS_AUX_TAP_eTPU | 10010 | Enables access to the eTPU Nexus TAP controller (eTPU_A, eTPU_B, CDC_AB) |
| ACCESS_AUX_TAP_NXDM | 10011 | Enables access to the eDMA_A Nexus TAP controller |
| ACCESS_AUX_TAP_NXFR | 10100 | Enables access to the FlexRay Nexus TAP controller |
| ACCESS_AUX_TAP_NXDM_B | 10111 | Enables access to the eDMA_B Nexus TAP controller |

Table 31-4. JTAG Client Select Instructions (continued)

| JTAGC Instruction | Opcode | Description |
|----------------------|--------|---|
| ACCESS_AUX_TAP_MULTI | 11100 | Serialize the JTAG instructions to all internal cores |
| BYPASS | 11111 | Bypass the TAP controller |

Table 31-5. Nexus Client JTAG Instructions

| Instruction | Description | Opcode |
|---|---|--------|
| NPC JTAG Instruction Opcodes | | |
| NEXUS_ENABLE | Opcode for NPC Nexus Enable instruction (4-bits) | 0x0 |
| BYPASS | Opcode for the NPC BYPASS instruction (4-bits) | 0xF |
| e200z7 OnCE JTAG Instruction Opcodes ¹ | | |
| NEXUS3_ACCESS | Opcode for e200z7 OnCE Nexus Enable instruction (10-bits) | 0x7C |
| BYPASS | Opcode for the e200z7 OnCE BYPASS instruction (10-bits) | 0x7F |
| eDMA Nexus JTAG Instruction Opcodes | | |
| NEXUS_ACCESS | Opcode for eDMA Nexus Enable instruction (4-bits) | 0x0 |
| BYPASS | Opcode for the eDMA Nexus BYPASS instruction (4-bits) | 0xF |
| FlexRay Nexus JTAG Instruction Opcodes | | |
| NEXUS_ACCESS | Opcode for FlexRay Nexus Enable instruction (4-bits) | 0x0 |
| BYPASS | Opcode for the FlexRay Nexus BYPASS instruction (4-bits) | 0xF |

¹ See the e200z7 Reference Manual for a complete list of available OnCE instructions.

31.4.2 Configuring the NDI for Nexus Messaging

The NDI is placed in disabled mode upon exit of power-on reset. If message transmission via the auxiliary port is desired, a write to the port configuration register (PCR) located in the NPC is then required to enable the NDI and select the mode of operation. Asserting MCKO_EN in the PCR places the NDI in enabled mode and enables MCKO. The frequency of MCKO is selected by writing the MCKO_DIV field. Asserting or negating the FPM bit selects full-port or reduced-port mode, respectively. When writing to the PCR, the PCR lsb (least significant bit) must be written to a logic 0. Setting the lsb of the PCR enables factory debug mode and prevents the transmission of Nexus messages.

Table 31-6 describes the NDI configuration options.

Table 31-6. NDI Configuration Options

| JCOMP Asserted | MCKO_EN bit of the Port Configuration Register | FPM bit of the Port Configuration Register | Configuration |
|----------------|--|--|---------------|
| No | X | X | Reset |
| Yes | 0 | X | Disabled |

Table 31-6. NDI Configuration Options

| JCOMP Asserted | MCKO_EN bit of the Port Configuration Register | FPM bit of the Port Configuration Register | Configuration |
|----------------|--|--|-------------------|
| Yes | 1 | 1 | Full-port mode |
| Yes | 1 | 0 | Reduced-port mode |

31.4.3 Programmable MCKO Frequency

MCKO is an output clock to the development tools used for the timing of $\overline{\text{MSE0}}$ and MDO pin functions. MCKO is derived from the system clock, and its frequency is determined by the value of the MCKO_DIV field in the port configuration register (PCR) located in the NPC. Possible operating frequencies include one-half, one-quarter, and one-eighth system clock speed.

Table 31-7 shows the MCKO_DIV encodings. In this table, SYS_CLK represents the core clock frequency. The default value selected if a reserved encoding is programmed is SYS_CLK divided by two

NOTE:

The SYS_CLK setting for MCKO should only be used if this setting does not violate the maximum operating frequency of the auxiliary port pins.

Table 31-7. MCKO_DIV Values

| MCKO_DIV[2:0] | MCKO Frequency ¹ |
|---------------|-----------------------------|
| 0b000 | SYS_CLK |
| 0b001 | SYS_CLK ÷ 2 |
| 0b010 | Invalid value |
| 0b011 | SYS_CLK ÷ 4 |
| 0b100 | Invalid value |
| 0b101 | Invalid value |
| 0b110 | Invalid value |
| 0b111 | SYS_CLK ÷ 8 |

¹ The SYS_CLK setting for MCKO should only be used if this setting does not violate the maximum operating frequency of the auxiliary port pins.

31.4.4 Nexus Messaging

Most of the messages transmitted by the NDI include a SRC field. This field is used to identify which source generated the message. Table 31-8 shows the values used for the SRC field by the different clients on the device. These 4-bit values are specific to the device. The same values are used for the client select values written to the client select control register.

Table 31-8. SRC Packet Encodings

| SRC[3:0] | Client |
|----------|-----------------------|
| 0b0000 | e200z7 |
| 0b0001 | eDMA_A |
| 0b0010 | eTPU_A |
| 0b0011 | eTPU_B |
| 0b0100 | eTPU CDC ¹ |
| 0b0101 | Reserved |
| 0b0110 | FlexRay |
| 0b0111 | eDMA_B |
| 0b1000 | Reserved |
| 0b1001 | Reserved |
| 0b1010 | Reserved |
| 0b1011 | Reserved |
| 0b1100 | Reserved |
| 0b1101 | Reserved |
| 0b1110 | Reserved |
| 0b1111 | Reserved |

¹ CDC is the eTPU Coherent Dual-Parameter Controller. See the *eTPU Reference Manual* for more information.

31.5 Nexus Port Controller (NPC)

The Nexus port controller (NPC) is that part of the NDI that controls access and arbitration of the device’s internal Nexus modules. The NPC contains the port configuration register (PCR) and the device identification register (DID). The contents of the NPC DID are the same as the JTAGC device identification register.

31.5.1 Overview

The device incorporates multiple modules that require development support. Each of these modules implements a development interface based on the IEEE-ISTO 5001-2001 standard and must share the input and output ports that interface with the development tool. The NPC controls the usage of these ports in a manner that allows the individual modules to share the ports, while appearing to the development tool as a single module.

31.5.2 Features

The NPC performs the following functions:

- Controls arbitration for ownership of the Nexus auxiliary output port
- Nexus device identification register and messaging
- Generates MCKO enable and frequency division control signals
- Controls sharing of $\overline{EVT0}$
- Control of the device-wide debug mode
- Generates asynchronous reset signal for Nexus modules based on JCOMP input, censorship status, and power-on reset status
- Provides Nexus support for censorship mode

31.6 NPC Memory Map and Register Definition

This section provides a detailed description of the NPC registers accessible to the end user. Individual bit-level descriptions and reset states of the registers are included.

31.6.1 Memory Map

[Table 31-9](#) shows the NPC registers by index values. The registers are not memory-mapped and can only be accessed via the TAP. The NPC does not implement the client select control register because the value does not matter when accessing the registers. The bypass register (see [Section 31.6.2.1, Bypass Register](#)) and instruction register (see [Section 31.6.2.2, Instruction Register](#)) have no index values. These registers are not accessed in the same manner as Nexus client registers.

Table 31-9. NPC Memory Map

| Index | Register | Bits | Access | Reset Value | Section/Page |
|-------|---------------------------------|------|--------|-------------|--------------------------------|
| 0 | DID—Device ID register | 32 | R | 0x0827_401D | 31.6.2.4/31-17 |
| 127 | PCR—Port configuration register | 32 | R/W | 0x0000_0000 | 31.6.2.4/31-17 |

31.6.2 Register Descriptions

This section consists of NPC register descriptions. Additional information regarding references to the TAP controller state can be found in [Section 32.4.3, TAP Controller State Machine](#).

31.6.2.1 Bypass Register

The bypass register is a single-bit shift register path selected for serial data transfer between TDI and TDO when the BYPASS instruction or any unimplemented instructions are active. After entry into the Capture-DR state, the single-bit shift register is set to a logic 0. Therefore, the first bit shifted out after selecting the bypass register is always a logic 0.

31.6.2.2 Instruction Register

The NPC uses a 4-bit instruction register as shown in [Figure 31-2](#). The instruction register is accessed via the SELECT_IR_SCAN path of the tap controller state machine, and allows instructions to be loaded into the module to enable the NPC for register access (NEXUS_ENABLE) or select the bypass register as the shift path from TDI to TDO (BYPASS or unimplemented instructions).

Instructions are shifted in through TDI while the TAP controller is in the Shift-IR state, and latched on the falling edge of TCK in the Update-IR state. The latched instruction value can only be changed in the Update-IR and test-logic-reset TAP controller states. Synchronous entry into the test-logic-reset state results in synchronous loading of the BYPASS instruction. Asynchronous entry into the test-logic-reset state results in asynchronous loading of the BYPASS instruction. During the Capture-IR TAP controller state, the instruction register is loaded with the value of the previously executed instruction, making this value the register's read value when the TAP controller is sequenced into the Shift-IR state.

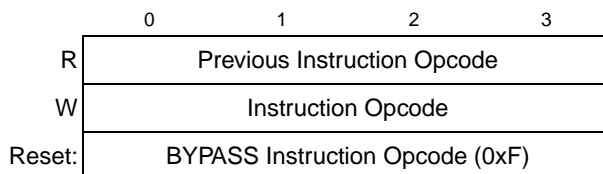

Figure 31-2. 4-Bit Instruction Register

31.6.2.3 Nexus Device ID Register (DID)

The NPC device identification register, shown in [Figure 31-3](#), allows the part revision number, design center, part identification number, and manufacturer identity code of the part to be determined through the auxiliary output port.

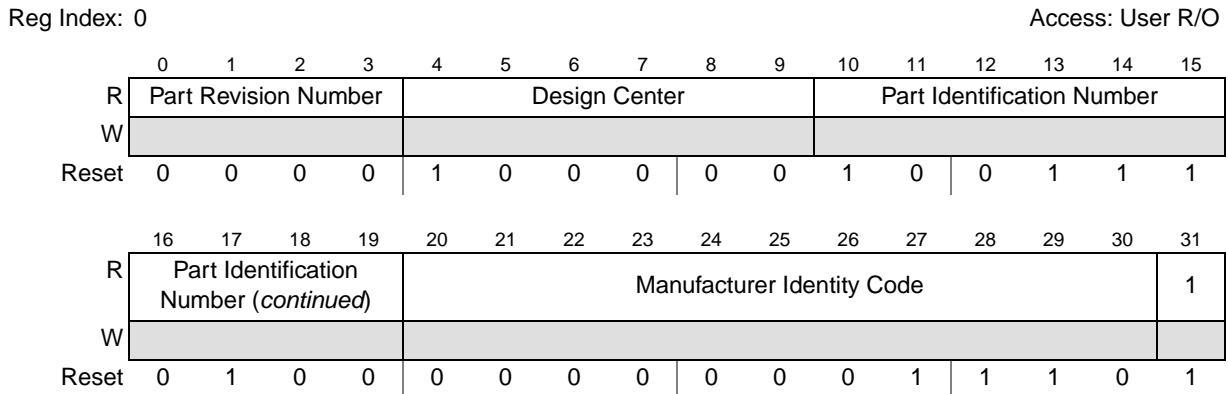

Figure 31-3. Nexus Device ID Register (DID)

Table 31-10. DID Register Field Descriptions

| Field | Description |
|--------------|--|
| 0–3 PRN | Part revision number. Contains the revision number of the part. This field changes with each revision of the device or module. |
| 4–9 DC | Design center. Indicates the Freescale design center. This value is 0x20. |
| 10–19 PIN | Part identification number. Contains the part number of the device. The PIN for the PXR40 is 0x274. |
| 20–30 MIC | Manufacturer identity code. Contains the reduced Joint Electron Device Engineering Council (JEDEC) ID for Freescale, 0x000E. |
| 31 | Fixed per JTAG 1149.1 Always set to 1. |

31.6.2.4 Port Configuration Register (PCR)

The PCR, shown in [Figure 31-4](#), is used to select the NPC mode of operation, enable MCKO and select the MCKO frequency, and enable or disable MCKO gating. This register must be configured as soon as the NPC is enabled.

NOTE

The mode (MCKO_GT) or clock division (MCKO_DIV) bits must not be modified after MCKO has been enabled. Changing the mode or clock division while MCKO is enabled can produce unpredictable results.

Reg Index: 127

Access: R/W

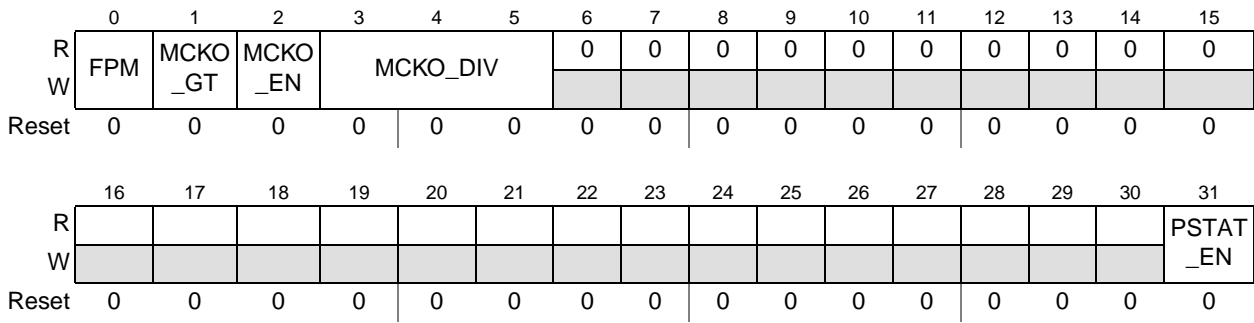

Figure 31-4. Port Configuration Register (PCR)

Table 31-11. PCR Field Descriptions

| Field | Description | | | | | | | | | | | | | | | | | | |
|-----------------|--|---------------|----------------|---|----------------------|---|-------------|---|---------------|---|-------------|---|---------------|---|---------------|---|---------------|---|-------------|
| 0 FPM | Full port mode. Determines if the auxiliary output port uses the full MDO port or a reduced MDO port to transmit messages. 0 The subset of MDO[11:0] pins are used to transmit messages. 1 All MDO[15:0] pins are used to transmit messages. Section 7.3.1.13, Pad Configuration Registers (SIU_PCR) , shows how GPIO is enabled or disabled by the FPM setting. | | | | | | | | | | | | | | | | | | |
| 1 MCKO_GT | MCKO clock gating control. Enables or disables MCKO clock gating. If clock gating is enabled, the MCKO clock is gated when the NPC is in enabled mode but not actively transmitting messages on the auxiliary output port. When clock gating is disabled, MCKO is allowed to run even if no auxiliary output port messages are being transmitted. 0 MCKO gating is disabled. 1 MCKO gating is enabled. | | | | | | | | | | | | | | | | | | |
| 2 MCKO_EN | MCKO enable. Enables the MCKO clock. When enabled, the frequency of MCKO is determined by the MCKO_DIV field. 0 MCKO clock is driven to zero. 1 MCKO clock is enabled. | | | | | | | | | | | | | | | | | | |
| 3–5 MCKO_DIV | MCKO division factor. Determines the frequency of MCKO relative to the system clock frequency when MCKO_EN is asserted. The table below shows the meaning of MCKO_DIV values. In this table, SYS_CLK represents the system clock frequency. <table border="1" style="margin-left: auto; margin-right: auto;"> <thead> <tr> <th>MCKO_DIV[2:0]</th> <th>MCKO Frequency</th> </tr> </thead> <tbody> <tr> <td>0</td> <td>SYS_CLK¹</td> </tr> <tr> <td>1</td> <td>SYS_CLK ÷ 2</td> </tr> <tr> <td>2</td> <td>Invalid value</td> </tr> <tr> <td>3</td> <td>SYS_CLK ÷ 4</td> </tr> <tr> <td>4</td> <td>Invalid value</td> </tr> <tr> <td>5</td> <td>Invalid value</td> </tr> <tr> <td>6</td> <td>Invalid value</td> </tr> <tr> <td>7</td> <td>SYS_CLK ÷ 8</td> </tr> </tbody> </table> | MCKO_DIV[2:0] | MCKO Frequency | 0 | SYS_CLK ¹ | 1 | SYS_CLK ÷ 2 | 2 | Invalid value | 3 | SYS_CLK ÷ 4 | 4 | Invalid value | 5 | Invalid value | 6 | Invalid value | 7 | SYS_CLK ÷ 8 |
| MCKO_DIV[2:0] | MCKO Frequency | | | | | | | | | | | | | | | | | | |
| 0 | SYS_CLK ¹ | | | | | | | | | | | | | | | | | | |
| 1 | SYS_CLK ÷ 2 | | | | | | | | | | | | | | | | | | |
| 2 | Invalid value | | | | | | | | | | | | | | | | | | |
| 3 | SYS_CLK ÷ 4 | | | | | | | | | | | | | | | | | | |
| 4 | Invalid value | | | | | | | | | | | | | | | | | | |
| 5 | Invalid value | | | | | | | | | | | | | | | | | | |
| 6 | Invalid value | | | | | | | | | | | | | | | | | | |
| 7 | SYS_CLK ÷ 8 | | | | | | | | | | | | | | | | | | |

¹ The SYS_CLK setting for MCKO should only be used if this setting does not violate the maximum operating frequency of the auxiliary port pins.

Table 31-11. PCR Field Descriptions (continued)

| Field | Description |
|----------------|--|
| 6–30 | Reserved |
| 31 PSTAT_EN | Processor status mode enable. Enables processor status (PSTAT) mode. In PSTAT mode, all auxiliary output port MDO pins are used to transmit processor status information, and Nexus messaging is unavailable. 0 PSTAT mode disabled 1 PSTAT mode enabled Note: PSTAT mode is intended for factory processor debug only. The PSTAT_EN bit must be written to disable PSTAT mode by the customer. No Nexus messages are transmitted under any circumstances when PSTAT mode is enabled |

31.7 NPC Functional Description

31.7.1 NPC Reset Configuration

The NPC is placed in disabled mode upon exit of reset. If message transmission via the auxiliary port is desired, a write to the PCR is then required to enable the NPC and select the mode of operation. Asserting MCKO_EN places the NPC in enabled mode and enables MCKO. The frequency of MCKO is selected by writing the MCKO_DIV field. Asserting or negating the FPM bit selects full-port or reduced-port mode, respectively.

[Table 31-6](#) describes the NPC reset configuration options.

31.7.2 Auxiliary Output Port

The auxiliary output port is shared by each of the Nexus modules on the device. The NPC communicates with each of the individual modules and arbitrates for access to the port. Additional information about the auxiliary port is found in [Section 31.2, External Signal Description](#).

31.7.2.1 Output Message Protocol

The protocol for transmitting messages via the auxiliary port is accomplished with the $\overline{\text{MSEO}}$ functions. The $\overline{\text{MSEO}}$ pins are used to signal the end of variable-length packets and the end of messages. They are not required to indicate the end of fixed-length packets. MDO and $\overline{\text{MSEO}}$ are sampled on the rising edge of MCKO.

[Figure 31-5](#) illustrates the state diagram for $\overline{\text{MSEO}}$ transfers. All transitions not included in the figure are reserved, and must not be used.

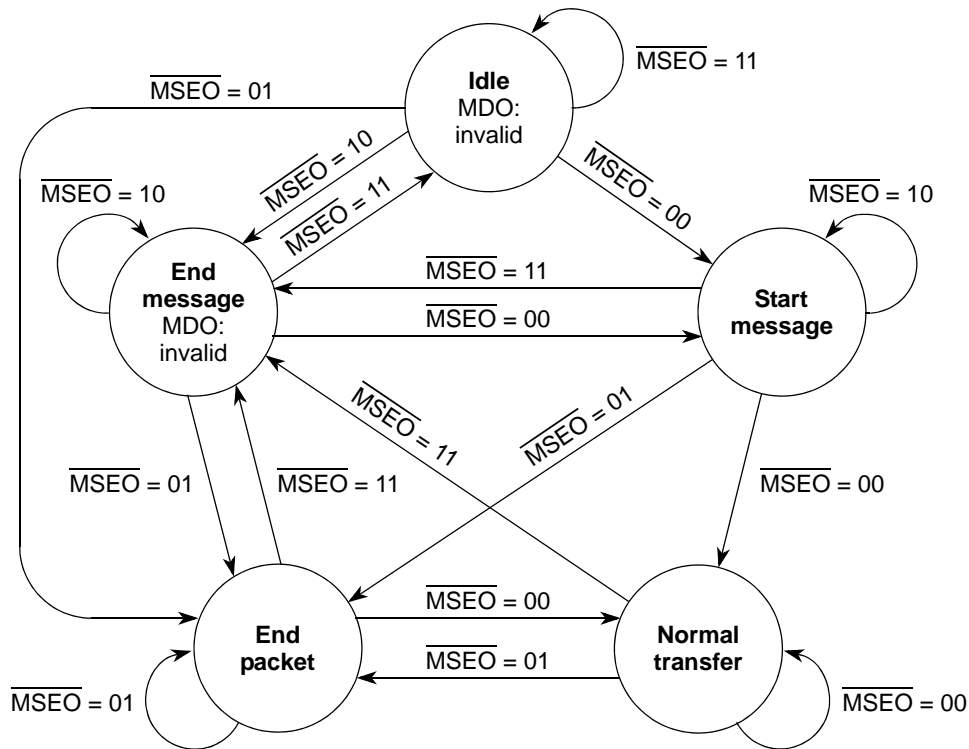

Figure 31-5. $\overline{\text{MSEO}}$ Transfers

31.7.2.2 Output Messages

In addition to sending out messages generated in other Nexus modules, the NPC can also output the device ID message contained in the device ID register on the MDO pins. The device ID message can also be sent out serially through TDO.

Table 31-12 describes the device ID message that the NPC can transmit on the auxiliary port. The TCODE is the first packet transmitted.

Table 31-12. NPC Output Messages

| Message Name | Min. Packet Bits | Max Packet Bits | Packet Type | Packet Name | Packet Description |
|-------------------|------------------|-----------------|-------------|-------------|-----------------------|
| Device ID Message | 6 | 6 | Fixed | TCODE | Value = 1 |
| | 32 | 32 | Fixed | ID | DID register contents |

Figure 31-6 shows the various message formats that the pin interface formatter has to encounter.

| Message | TCODE | Field #1 | Field #2 | Field #3 | Field #4 | Field #5 | Min. Size ¹ Bits | Max. Size ² Bits |
|-------------------|-------|------------|----------|----------|----------|----------|--------------------------------|--------------------------------|
| Device ID Message | 1 | Fixed = 32 | — | — | — | — | 38 | 38 |

¹ Minimum information size. The actual number of bits transmitted depends on the number of MDO pins

² Maximum information size. The actual number of bits transmitted depends on the number of MDO pins

Figure 31-6. Message Field Sizes

The double edges in [Figure 31-6](#) indicate the starts and ends of messages. Fields without shaded areas between them are grouped into super-fields and can be transmitted together without end-of-packet indications between them.

31.7.2.2.1 Rules of Messages

The rules of messages include the following:

- A variable-sized field within a message must end on a port boundary. (Port boundaries depend on the number of MDO pins active with the current reset configuration.)
- A variable-sized field can start within a port boundary only when following a fixed-length field.
- Super-fields must end on a port boundary.
- When a variable-length field is sized such that it does not end on a port boundary, it is necessary to extend and zero fill the remaining bits after the highest order bit so that it can end on a port boundary.
- Multiple fixed-length packets can start and/or end on a single clock.
- When any packet follows a variable-length packet, it must start on a port boundary.
- The field containing the TCODE number is always transferred out first, followed by subsequent fields of information.
- Within a field, the lowest significant bits are shifted out first. [Figure 31-7](#) shows the transmission sequence of a message that is made up of a TCODE followed by three fields.

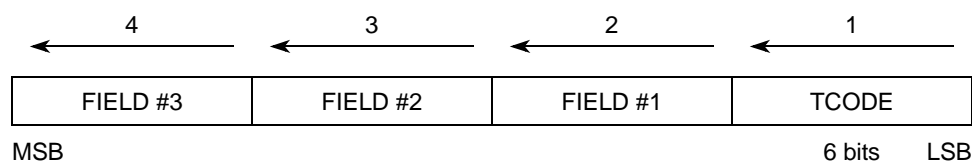

Figure 31-7. Transmission Sequence of Messages

31.7.2.3 IEEE 1149.1-2001 (JTAG) TAP

The NPC uses the IEEE 1149.1-2001 TAP for accessing registers. Each of the individual Nexus modules on the device implements a TAP controller for accessing its registers as well. TAP signals include TCK, TDI, TMS, and TDO. Detailed information about the TAP controller state machine can be found in [Section 32.4.3, TAP Controller State Machine](#).

The IEEE 1149.1-2001 specification can be ordered for further detail on electrical and pin protocol compliance requirements.

The NPC implements a Nexus controller state machine that transitions based on the state of the IEEE 1149.1-2001 state machine shown in [Figure 31-5](#). The Nexus controller state machine is defined by the IEEE-ISTO 5001-2011. It is shown in [Figure 31-10](#).

The instructions implemented by the NPC TAP controller are listed in [Table 31-13](#). The value of the NEXUS-ENABLE instruction is 0b0000. Each unimplemented instruction acts like the BYPASS instruction. The size of the NPC instruction register is 4-bits.

Table 31-13. Implemented Instructions

| Instruction Name | Private/Public | Opcode | Description |
|------------------|----------------|--------|---|
| NEXUS-ENABLE | Public | 0x0 | Activate Nexus controller state machine to read and write NPC registers. |
| BYPASS | Private | 0xF | NPC BYPASS instruction. Also the value loaded into the NPC IR upon exit of reset. |

Data is shifted between TDI and TDO starting with the least significant bit as illustrated in [Figure 31-8](#). This applies for the instruction register and all Nexus tool-mapped registers.

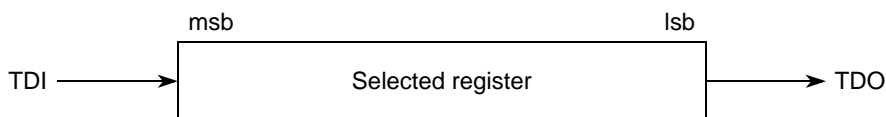
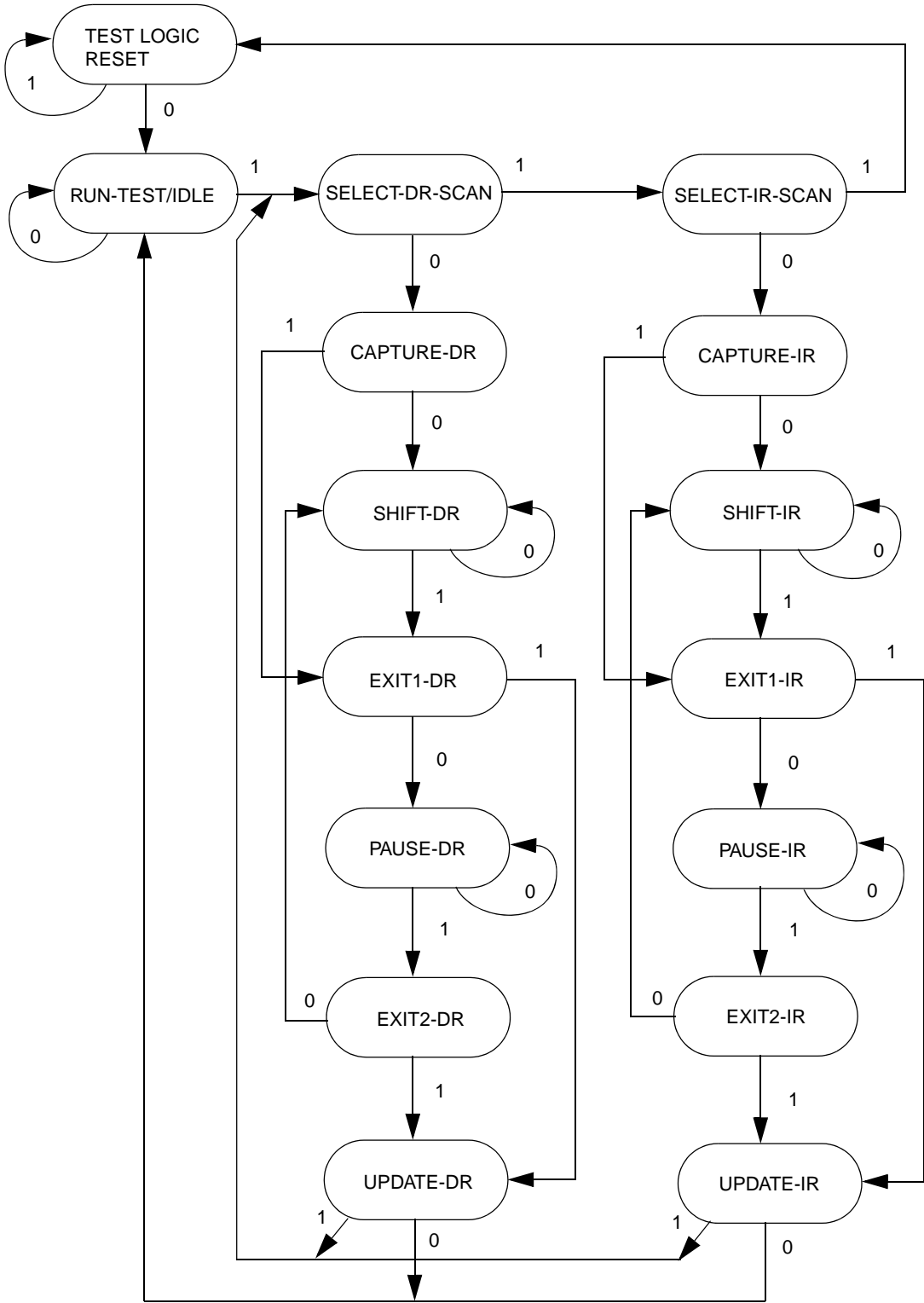

Figure 31-8. Shifting Data Into a Register

31.7.2.3.1 Enabling the NPC TAP Controller

Assertion of the power-on reset signal or negating JCOMP resets the NPC TAP controller. When not in power-on reset, the NPC TAP controller is enabled by asserting JCOMP and loading the ACCESS_AUX_TAP_NPC instruction in the JTAGC. Loading the NEXUS-ENABLE instruction then grants access to NPC registers.



NOTE: The value shown adjacent to each state transition in this figure represents the value of TMS at the time of a rising edge of TCK.

Figure 31-9. IEEE 1149.1-2001 TAP Controller State Machine

31.7.2.3.2 Retrieving Device IDCODE

The Nexus TAP controller does not implement the IDCODE instruction. However, the device identification message can be output by the NPC through the auxiliary output port or shifted out serially by accessing the NPC device ID register through the TAP. If the NPC is enabled, transmission of the device identification message on the auxiliary output port MDO pins occurs immediately after a write to the PCR. Transmission of the device identification message serially through TDO is achieved by performing a read of the register contents as described in [Section 31.7.2.3.4, Selecting a Nexus Client Register](#).

31.7.2.3.3 Loading NEXUS-ENABLE Instruction

Access to the NPC registers is enabled by loading the NPC NEXUS-ENABLE instruction when NPC has ownership of the TAP. This instruction is shifted in via the SELECT-IR-SCAN path and loaded in the UPDATE-IR state. At this point, the Nexus controller state machine, shown in [Figure 31-10](#), transitions to the REG_SELECT state. The Nexus controller has three states: idle, register select, and data access. [Table 31-14](#) illustrates the IEEE 1149.1 sequence to load the NEXUS-ENABLE instruction.

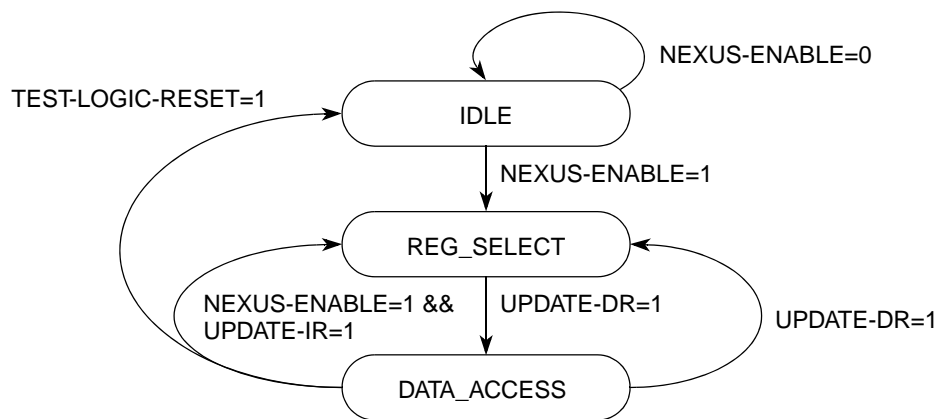

Figure 31-10. NEXUS Controller State Machine

Table 31-14. Loading NEXUS-ENABLE Instruction

| Clock | TDI | TMS | IEEE 1149.1 State | Nexus State | Description |
|-------|-----|-----|--------------------|-------------|---|
| 0 | — | 0 | RUN-TEST/IDLE | IDLE | IEEE 1149.1-2001 TAP controller in idle state |
| 1 | — | 1 | SELECT-DR-SCAN | IDLE | Transitional state |
| 2 | — | 1 | SELECT-IR-SCAN | IDLE | Transitional state |
| 3 | — | 0 | CAPTURE-IR | IDLE | Internal shifter loaded with current instruction |
| 4 | — | 0 | SHIFT-IR | IDLE | TDO becomes active, and the IEEE 1149.1-2001 shifter is ready. Shift in all but the last bit of the NEXUS_ENABLE instruction. |
| 5-7 | 0 | 0 | 3 TCKS in SHIFT-IR | IDLE | |
| 8 | 0 | 1 | EXIT1-IR | IDLE | Last bit of instruction shifted in |
| 9 | — | 1 | UPDATE-IR | IDLE | NEXUS-ENABLE loaded into instruction register |
| 10 | — | 0 | RUN-TEST/IDLE | REG_SELECT | Ready to be read/write Nexus registers |

31.7.2.3.4 Selecting a Nexus Client Register

When the NEXUS-ENABLE instruction is decoded by the TAP controller, the input port allows development tool access to all Nexus registers. Each register has a 7-bit address index.

All register access is performed via the SELECT-DR-SCAN path of the IEEE 1149.1–2001 TAP controller state machine. The Nexus controller defaults to the REG_SELECT state when enabled. Accessing a register requires two passes through the SELECT-DR-SCAN path: one pass to select the register and the second pass to read/write the register.

The first pass through the SELECT-DR-SCAN path is used to enter an 8-bit Nexus command consisting of a read/write control bit in the lsb followed by a 7-bit register address index, as illustrated in [Figure 31-11](#). The read/write control bit is set to 1 for writes and 0 for reads.

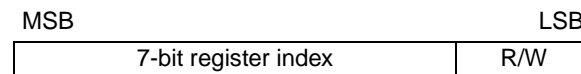

Figure 31-11. IEEE 1149.1 Controller Command Input

The second pass through the SELECT-DR-SCAN path is used to read or write the register data by shifting in the data (lsb first) during the SHIFT-DR state. When reading a register, the register value is loaded into the IEEE 1149.1-2001 shifter during the CAPTURE-DR state. When writing a register, the value is loaded from the IEEE 1149.1-2001 shifter to the register during the UPDATE-DR state. When reading a register, there is no requirement to shift out the entire register contents. Shifting can be terminated after the required number of bits have been acquired.

[Table 31-15](#) illustrates a sequence that writes a 32-bit value to a register.

Table 31-15. Write to a 32-Bit Nexus Client Register

| Clock | TMS | IEEE 1149.1 State | Nexus State | Description |
|---------|-----|-------------------|-------------|---|
| 0 | 0 | RUN-TEST/IDLE | REG_SELECT | IEEE 1149.1-2001 TAP controller in idle state |
| 1 | 1 | SELECT-DR-SCAN | REG_SELECT | First pass through SELECT-DR-SCAN path |
| 2 | 0 | CAPTURE-DR | REG_SELECT | Internal shifter loaded with current value of controller command input. |
| 3 | 0 | SHIFT-DR | REG_SELECT | TDO becomes active, and write bit and 6 bits of register index shifted in. |
| 7 TCKs | | | | |
| 11 | 1 | EXIT1-DR | REG_SELECT | Last bit of register index shifted into TDI |
| 12 | 1 | UPDATE-DR | REG_SELECT | Controller decodes and selects register |
| 13 | 1 | SELECT-DR-SCAN | DATA_ACCESS | Second pass through SELECT-DR-SCAN path |
| 14 | 0 | CAPTURE-DR | DATA_ACCESS | Internal shifter loaded with current value of register |
| 15 | 0 | SHIFT-DR | DATA_ACCESS | TDO becomes active, and outputs current value of register while new value is shifted in through TDI |
| 31 TCKs | | | | |
| 47 | 1 | EXIT1-DR | DATA_ACCESS | Last bit of current value shifted out TDO. Last bit of new value shifted in TDI. |

Table 31-15. Write to a 32-Bit Nexus Client Register (continued)

| Clock | TMS | IEEE 1149.1 State | Nexus State | Description |
|-------|-----|-------------------|-------------|--|
| 48 | 1 | UPDATE-DR | DATA_ACCESS | Value written to register |
| 49 | 0 | RUN-TEST/IDLE | REG_SELECT | Controller returned to idle state. It could also return to SELECT-DR-SCAN to write another register. |

31.7.2.4 Nexus Auxiliary Port Sharing

Each of the Nexus modules on the MCU implements a request/grant scheme to arbitrate for control of the Nexus auxiliary port when Nexus data is ready to be transmitted.

All modules arbitrating for the port are given fixed priority levels relative to each other. If multiple modules have the same request level, this priority level is used as a tie-breaker. To avoid monopolization of the port, the module given the highest priority level alternates following each grant. Immediately out of reset the order of priority, from highest to lowest, is: NPC, NZ7C3, NDEDI, NXDM and NXFR. This arbitration mechanism is controlled internally and is not programmable by tools or the user.

31.7.2.5 Nexus JTAG Port Sharing

Each of the individual Nexus modules on the device implements a TAP controller for accessing its registers. When JCOMP is asserted, only the module whose ACCESS_AUX_TAP instruction is loaded has control of the TAP (see [Section 32.4.4, JTAGC Instructions](#)). This allows the interface to all of these individual TAP controllers to appear to be a single port from outside the device. After a Nexus module has ownership of the TAP, that module acts like a single-bit shift register, or bypass register, if no register is selected as the shift path.

31.7.2.6 MCKO

MCKO is an output clock to the development tools used for the timing of $\overline{\text{MSE0}}$ and MDO pin functions. MCKO is derived from the system clock and its frequency is determined by the value of the MCKO_DIV[2:0] field in the PCR. Possible operating frequencies include one-half, one-quarter, and one-eighth system clock speed. MCKO is enabled by setting the MCKO_EN bit in the PCR.

The NPC also controls dynamic MCKO clock gating when in full- or reduced-port modes. The setting of the MCKO_GT bit inside the PCR determines whether or not MCKO gating control is enabled. The MCKO_GT bit resets to a logic 0. In this state gating of MCKO is disabled. To enable gating of MCKO, the MCKO_GT bit in the PCR is written to a logic 1. When MCKO gating is enabled, MCKO is driven to a logic 0 if the auxiliary port is enabled but not transmitting messages and there are no pending messages from Nexus clients.

31.7.2.7 $\overline{\text{EVTO}}$ Sharing

The NPC controls sharing of the $\overline{\text{EVTO}}$ output between all Nexus clients that produce an $\overline{\text{EVTO}}$ signal. $\overline{\text{EVTO}}$ is driven for one MCKO period whenever any module drives its $\overline{\text{EVTO}}$. When there is no active MCKO, such as in disabled mode, the NPC assumes an MCKO frequency of one-half system clock speed when driving $\overline{\text{EVTO}}$. $\overline{\text{EVTO}}$ sharing is active as long as the NPC is not in reset.

31.7.2.8 Nexus Reset Control

The JCOMP input that is used as the primary reset signal for the NPC is also used by the NPC to generate a single-bit reset signal for other Nexus modules. If JCOMP is negated, an internal reset signal is asserted, indicating that all Nexus modules must be held in reset. This internal reset signal is also asserted during a power-on reset. This single bit reset signal functions much like the IEEE 1149.1-2001 defined $\overline{\text{TRST}}$ signal and allows JCOMP reset information to be provided to the Nexus modules without each module having to sense the JCOMP signal directly.

31.8 NPC Initialization and Application Information

31.8.1 Accessing NPC Tool-Mapped Registers

To initialize the TAP for NPC register accesses, the following sequence is required:

1. Enable the NPC TAP controller. This is achieved by asserting JCOMP and loading the ACCESS_AUX_TAP_NPC instruction in the JTAGC.
2. Load the TAP controller with the NEXUS-ENABLE instruction.

To write control data to NPC tool-mapped registers, the following sequence is required:

1. Write the 7-bit register index and set the write bit to select the register with a pass through the SELECT-DR-SCAN path in the TAP controller state machine.
2. Write the register value with a second pass through the SELECT-DR-SCAN path. The prior value of this register is shifted out during the write.

To read status and control data from NPC tool-mapped registers, the following sequence is required:

1. Write the 7-bit register index and clear the write bit to select register with a pass through SELECT-DR-SCAN path in the TAP controller state machine.
2. Read the register value with a second pass through the SELECT-DR-SCAN path. Data shifted in is ignored.

See the IEEE-ISTO 5001-2011 standard for more detail.

31.9 Nexus Dual eTPU Development Interface (NDEDI)

The enhanced timing processor unit (eTPU) has its own Nexus class 3 interface, the Nexus dual eTPU development interface (NDEDI). The two eTPU engines and a coherent dual parameter controller (CDC) appear as three separate Nexus clients. See the *Enhanced Time Processor Unit Reference Manual* for more information about the NDEDI module.

Reg Index: 0

Access: R/O

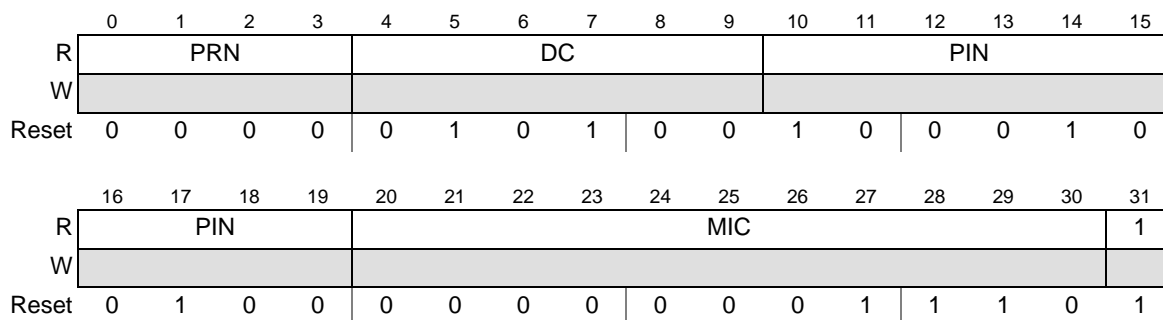

Figure 31-12. NDEDI Device ID Register (DID)

Table 31-16. NDEDI DID Register Field Descriptions

| Field | Description |
|--------------|--|
| 0–3 PRN | Part revision number. Contains the revision number of the part. This field changes with each revision of the device or module. |
| 4–9 DC | Design center. Indicates the Freescale design center. This value is 0x20. |
| 10–19 PIN | Part identification number. Contains the part number of the device. The PIN for the PXR40 is 0x224. |
| 20–30 MIC | Manufacturer identity code. Contains the reduced Joint Electron Device Engineering Council (JEDEC) ID for Freescale, 0xE. |
| 31 | Fixed per JTAG 1149.1 1 Always set |

31.10 e200z7 Class 3 Nexus Module (NZ7C3)

The NZ7C3 module provides real-time development capabilities for the device core in compliance with the IEEE-ISTO 5001-2011 standard. This module provides development support capabilities without requiring the use of address and data pins for internal visibility.

31.10.1 Introduction

This section defines the auxiliary pin functions, transfer protocols and standard development features of the NZ7C3 module. The development features supported are Program trace, data trace, watchpoint messaging, ownership trace, and read/write access via the JTAG interface.

NOTE

Throughout this section references are made to the auxiliary port and its specific signals, such as MCKO, $\overline{\text{MSEO}}[1:0]$, MDO[15:0] and others. The device NPC module arbitrates the access of the single auxiliary port. To simplify the description of the function of the NZ7C3 module, the interaction of the NPC is omitted and the configuration in this chapter describes an NPC with a dedicated auxiliary port. The auxiliary port is fully described in [Section 31.2, External Signal Description](#).

31.10.2 Block Diagram

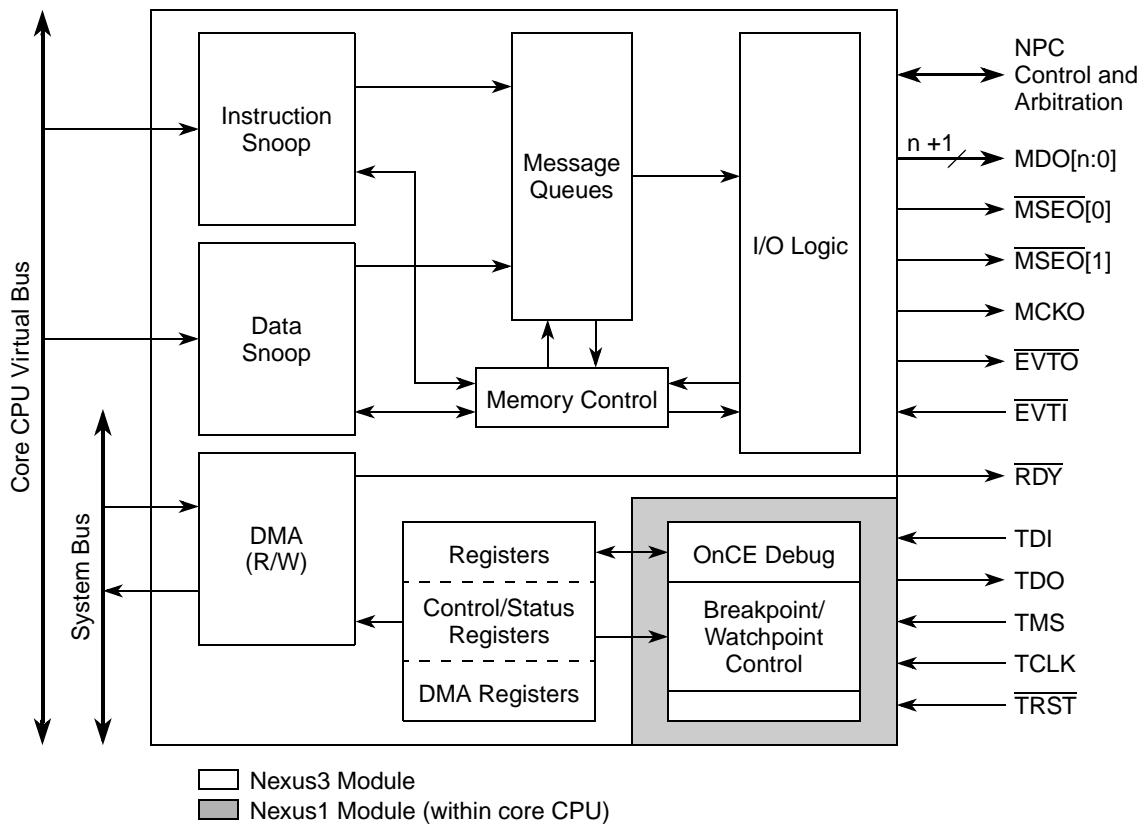

Figure 31-13. e200z7 Nexus3 Functional Block Diagram

31.10.3 Overview

[Table 31-17](#) contains a set of terms and definitions associated with the NZ7C3 module.

Table 31-17. Terms and Definitions

| Term | Description |
|-------------------------------|---|
| IEEE-ISTO 5001 | Consortium and standard for real-time embedded system design. World wide Web documentation at http://www.ieee-isto.org/Nexus5001 |
| Auxiliary Port | Refers to Nexus auxiliary port. Used as auxiliary port to the IEEE 1149.1 JTAG interface. |
| Branch Trace Messaging (BTM) | Visibility of addresses for taken branches and exceptions, and the number of sequential instructions executed between each taken branch. |
| Client | A functional block on an embedded processor which requires development visibility and controllability. Examples are a central processing unit (CPU) or an intelligent peripheral. |
| Data Read Message (DRM) | External visibility of data reads to memory-mapped resources. |
| Data Write Message (DWM) | External visibility of data writes to memory-mapped resources. |
| Data Trace Messaging (DTM) | External visibility of how data flows through the embedded system. This can include DRM and/or DWM. |
| JTAG Compliant | Device complying to IEEE 1149.1 JTAG standard |
| JTAG IR & DR Sequence | JTAG instruction register (IR) scan to load an opcode value for selecting a development register. The JTAG IR corresponds to the OnCE command register (OCMD). The selected development register is then accessed via a JTAG data register (DR) scan. |
| Nexus1 | The e200z7 (OnCE) debug module. This module integrated with each e200z7 processor provides all static (core halted) debug functionality. This module is compliant with Class1 of the IEEE-ISTO 5001 standard. |
| Ownership Trace Message (OTM) | Visibility of process/function that is currently executing. |
| Public Messages | Messages on the auxiliary pins for accomplishing common visibility and controllability requirements |
| Standard | The phrase 'according to the standard' is used to indicate according to the IEEE-ISTO 5001 standard. |
| Transfer Code (TCODE) | Message header that identifies the number and/or size of packets to be transferred, and how to interpret each of the packets. |
| Watchpoint | A data or instruction breakpoint which does not cause the processor to halt. Instead, a pin is used to signal that the condition occurred. A watchpoint message is also generated. |

31.10.4 Features

The NZ7C3 module is compliant with Class 3 of the IEEE-ISTO 5001-2011 standard. The following features are implemented:

- Program trace via branch trace messaging (BTM). Branch trace messaging displays program flow discontinuities (direct and indirect branches, exceptions, etc.), allowing the development tool to interpolate what transpires between the discontinuities. Thus static code can be traced.
- Data trace via data write messaging (DWM) and data read messaging (DRM). This provides the capability for the development tool to trace reads and/or writes to selected internal memory resources.
- Ownership trace via ownership trace messaging (OTM). OTM facilitates ownership trace by providing visibility of which process ID or operating system task is activated. An ownership trace message is transmitted when a new process/task is activated, allowing the development tool to trace ownership flow.
- Run-time access to embedded processor registers and memory map via the JTAG port. This allows for enhanced download/upload capabilities.
- Watchpoint messaging via the auxiliary pins.
- Watchpoint trigger enable of program and/or data trace messaging.
- High-speed data input/output via the auxiliary port.
- Auxiliary interface for higher data input/output
 - Configurable (minimum and maximum) message data out pins
 - One read/write ready pin
 - One watchpoint-event pin
 - One event-in pin
 - One MCKO (message clock out) pin
- Registers for program trace, data trace, ownership trace and watchpoint trigger.
- All features controllable and configurable via the JTAG port.

31.10.5 Enabling Nexus3 Operation

The Nexus module is enabled by loading a single instruction (`ACCESS_AUX_TAP_ONCE`, as shown in [Table 31-4](#)) into the JTAGC instruction register (IR), and then loading the corresponding OnCE OCMD register with the `NEXUS3_ACCESS` instruction (see [Table 31-5](#)). For the e200z7 Class 3 Nexus module, the OCMD value is `0b00_0111_1100`. After it is enabled, the module is ready to accept control input via the JTAG pins. See [Section 31.7, NPC Functional Description](#), for more information.

The Nexus module is disabled when the JTAG state machine reaches the test-logic-reset state. This state can be reached by asserting the JCOMP pin or cycling through the state machine using the TMS pin. The Nexus module is also disabled if a power-on-reset (POR) event occurs. If the Nexus3 module is disabled, no trace output is provided, and the module disables (drive inactive) auxiliary port output pins `MDO[n:0]`, `MSEO[1:0]`, `MCKO`. Nexus registers are not available for reads or writes.

31.10.6 TCODEs Supported by NZ7C3

The Nexus3 pins allow for flexible transfer operations via public messages. A TCODE defines the transfer format, the number and/or size of the packets to be transferred, and the purpose of each packet. The IEEE-ISTO 5001-2011 standard defines a set of public messages. The NZ7C3 module supports the public TCODEs seen in [Table 31-18](#). Each message contains multiple packets transmitted in the order shown in the table.

Table 31-18. Public TCODEs Supported by NZ7C3

| Message Name | Packet Size (bits) | | Packet Name | Packet Type | Packet Description |
|--|--------------------|-----|-------------|-------------|---|
| | Min | Max | | | |
| Debug Status | 6 | 6 | TCODE | Fixed | TCODE number = 0 (0x00) |
| | 4 | 4 | SRC | Fixed | Source processor identifier |
| | 8 | 8 | STATUS | Fixed | Development status register (DS[31:24]) |
| Ownership Trace Message | 6 | 6 | TCODE | Fixed | TCODE number = 2 (0x02) |
| | 4 | 4 | SRC | Fixed | Source processor identifier |
| | 32 | 32 | PROCESS | Fixed | Task/Process ID tag |
| Program Trace - Direct Branch Message ¹ | 6 | 6 | TCODE | Fixed | TCODE number = 3 (0x03) |
| | 4 | 4 | SRC | Fixed | Source processor identifier |
| | 1 | 8 | I-CNT | Variable | Number of sequential instructions executed since last taken branch |
| Program Trace - Indirect Branch Message ¹ | 6 | 6 | TCODE | Fixed | TCODE number = 4 (0x04) |
| | 4 | 4 | SRC | Fixed | Source processor identifier |
| | 1 | 8 | I-CNT | Variable | Number of sequential instructions executed since last taken branch |
| | 1 | 32 | U-ADDR | Variable | Unique part of target address for taken branches/exceptions |
| Data Trace - Data Write Message | 6 | 6 | TCODE | Fixed | TCODE number = 5 (0x05) |
| | 4 | 4 | SRC | Fixed | Source processor identifier |
| | 3 | 3 | DSIZ | Fixed | Data size (see Table 31-22) |
| | 1 | 32 | U-ADDR | Variable | Unique portion of the data write address |
| | 1 | 64 | DATA | Variable | Data write values (see Section 31.14.6, Data Trace , for details) |

Table 31-18. Public TCODEs Supported by NZ7C3 (continued)

| Message Name | Packet Size (bits) | | Packet Name | Packet Type | Packet Description |
|--|--------------------|-----|-------------|-------------|---|
| | Min | Max | | | |
| Data Trace - Data Read Message | 6 | 6 | TCODE | Fixed | TCODE number = 6 (0x06) |
| | 4 | 4 | SRC | Fixed | Source processor identifier |
| | 3 | 3 | DSIZ | Fixed | Data size (see Table 31-22) |
| | 1 | 32 | U-ADDR | Variable | Unique portion of the data read address |
| | 1 | 64 | DATA | Variable | Data read values (see Section 31.14.6, Data Trace , for details) |
| Error Message | 6 | 6 | TCODE | Fixed | TCODE number = 8 (0x08) |
| | 4 | 4 | SRC | Fixed | Source processor identifier |
| | 5 | 5 | ECODE | Fixed | Error code |
| Program Trace - Direct Branch Message w/ Sync ¹ | 6 | 6 | TCODE | Fixed | TCODE number = 11 (0x0B) |
| | 4 | 4 | SRC | Fixed | Source processor identifier |
| | 1 | 8 | I-CNT | Variable | Number of sequential instructions executed since last taken branch |
| | 1 | 32 | F-ADDR | Variable | Full target address (leading zeros truncated) |
| Program Trace - Indirect Branch Message w/ Sync ¹ | 6 | 6 | TCODE | Fixed | TCODE number = 12 (0x0C) |
| | 4 | 4 | SRC | Fixed | Source processor identifier |
| | 1 | 8 | I-CNT | Variable | Number of sequential instructions executed since last taken branch |
| | 1 | 32 | F-ADDR | Variable | Full target address (leading zeros truncated) |
| Data Trace - Data Write Message w/ Sync | 6 | 6 | TCODE | Fixed | TCODE number = 13 (0x0D) |
| | 4 | 4 | SRC | Fixed | Source processor identifier |
| | 3 | 3 | DSZ | Fixed | Data size (see Table 31-22) |
| | 1 | 32 | F-ADDR | Variable | Full access address (leading zeros truncated) |
| | 1 | 64 | DATA | Variable | Data write values (see Section 31.14.6, Data Trace , for details) |
| Data Trace - Data Read Message w/ Sync | 6 | 6 | TCODE | Fixed | TCODE number = 14 (0x0E) |
| | 4 | 4 | SRC | Fixed | Source processor identifier |
| | 3 | 3 | DSZ | Fixed | Data size (see Table 31-22) |
| | 1 | 32 | F-ADDR | Variable | Full access address (leading zeros truncated) |
| | 1 | 64 | DATA | Variable | Data read values (see Section 31.14.6, Data Trace , for details) |

Table 31-18. Public TCODEs Supported by NZ7C3 (continued)

| Message Name | Packet Size (bits) | | Packet Name | Packet Type | Packet Description |
|---|--------------------|-----|-------------|-------------|--|
| | Min | Max | | | |
| Watchpoint Message | 6 | 6 | TCODE | Fixed | TCODE number = 15 (0x0F) |
| | 4 | 4 | SRC | Fixed | Source processor identifier |
| | 4 | 4 | WPHIT | Fixed | Number indicating watchpoint sources |
| Resource Full Message | 6 | 6 | TCODE | Fixed | TCODE number = 27 (0x1B) |
| | 4 | 4 | SRC | Fixed | Source processor identifier |
| | 4 | 4 | RCODE | Fixed | Resource code indicates which resource is the cause of this message (See RCODE values in Table 31-21) |
| | 1 | 32 | RDATA | Variable | Branch / predicate instruction history (see Section 31.13.1, Branch Trace Messaging (BTM)) |
| Program Trace - Indirect Branch History Message | 6 | 6 | TCODE | Fixed | TCODE number = 28 (0x1C) (see footnote 1 below) |
| | 4 | 4 | SRC | Fixed | Source processor identifier |
| | 1 | 8 | I-CNT | Variable | Number of sequential instructions executed since last taken branch |
| | 1 | 32 | U-ADDR | Variable | Unique part of target address for taken branches/exceptions |
| | 1 | 32 | HIST | Variable | Branch / predicate instruction history (see Section 31.13.1, Branch Trace Messaging (BTM)) |
| Program Trace - Indirect Branch History Message w/ Sync | 6 | 6 | TCODE | Fixed | TCODE number = 29 (0x1D) (see footnote 1 below) |
| | 4 | 4 | SRC | Fixed | Source processor identifier |
| | 1 | 8 | I-CNT | Variable | Number of sequential instructions executed since last taken branch |
| | 1 | 32 | F-ADDR | Variable | Full target address (leading zero (0) truncated) |
| | 1 | 32 | HIST | Variable | Branch / predicate instruction history (see Section 31.13.1, Branch Trace Messaging (BTM)) |
| Program Trace - Program Correlation Message | 6 | 6 | TCODE | Fixed | TCODE number = 33 (0x21) |
| | 4 | 4 | SRC | Fixed | Source processor identifier |
| | 4 | 4 | EVCODE | Fixed | Event correlated w/ program flow (see Table 31-21) |
| | 1 | 8 | I-CNT | Variable | Number of sequential instructions executed since last taken branch |
| | 1 | 32 | HIST | Variable | Branch / predicate instruction history (see Section 31.13.1, Branch Trace Messaging (BTM)) |

¹ You can select between the two types of program trace. The advantages for each are discussed in [Section 31.13.1, Branch Trace Messaging \(BTM\)](#). If the branch history method is selected, the shaded TCODES above are not messaged out.

[Table 31-19](#) shows the error code encodings used when reporting an error via the Nexus3 Error Message.

Table 31-19. Error Code Encoding (TCODE = 8)

| Error Code (ECODE) | Description |
|--------------------|---|
| 00000 | Ownership trace overrun |
| 00001 | Program trace overrun |
| 00010 | Data trace overrun |
| 00011 | Read/write access error |
| 00101 | Invalid access opcode (Nexus register unimplemented) |
| 00110 | Watchpoint overrun |
| 00111 | (Program trace or data trace) and ownership trace overrun |
| 01000 | (Program trace or data trace or ownership trace) and watchpoint overrun |
| 01001–10111 | Invalid value |
| 11000 | BTM lost due to collision w/ higher priority message |
| 11001–11111 | Invalid value |

Table 31-20 shows the encodings used for resource codes for certain messages.

Table 31-20. RCODE values (TCODE = 27)

| Resource Code (RCODE) | Description | Resource Data (RDATA) |
|-----------------------|---|--|
| 0000 | Program Trace Instruction Counter overflow (reached 255 and was reset) | 0xFF |
| 0001 | Program Trace, Branch and Predicate Instruction History. This type of packet is terminated by a stop bit set to 1 after the last history bit. | Branch History. This type of packet is terminated by a stop bit set to a 1 after the last history bit. |

Table 31-21 shows the event code encodings used for certain messages.

Table 31-21. Event Code Encoding (TCODE = 33)

| Event Code | Description |
|------------|---|
| 0000 | Entry into Debug Mode |
| 0001 | Entry into Low Power Mode (CPU only) ¹ |
| 0010–0011 | Invalid value. Reserved for future functionality |
| 0100 | Disabling Program Trace |

¹ The device enters Low Power Mode when the Nexus stall mode is enabled (NZ7C3_DC1[OVC]=0b011) and a trace message is in danger of over-flowing the Nexus queue.

Table 31-22 shows the data trace size encodings used for certain messages.

Table 31-22. Data Trace Size Encodings (TCODE = 5, 6, 13, 14)

| DTM Size Encoding | Transfer Size |
|-------------------|--------------------------|
| 000 | Byte |
| 001 | Halfword (two bytes) |
| 010 | Word (four bytes) |
| 011 | Doubleword (eight bytes) |
| 100 | String (three bytes) |
| 101–111 | Invalid value |

NOTE

Program trace can be implemented using either branch history/predicate instruction messages, or traditional direct and indirect branch messages. The user can select between the two types of Program Trace. The advantages for each are discussed in [Section 31.13.1, Branch Trace Messaging \(BTM\)](#). If the Branch History method is selected, the shaded TCODES are not messaged out.

31.11 NZ7C3 Memory Map and Register Definition

Refer to the Nexus 3 Programmer’s Model section in the *e200z7 PowerPC™ Core Reference Manual* for the description of the NZ7C3 programmer’s model. NZ7C3 registers are accessed using the JTAG/OnCE port in compliance with IEEE 1149.1.

NOTE

Nexus 3 registers and output signals are numbered using bit 0 as the least significant bit. This bit ordering is consistent with the ordering defined by the IEEE-ISTO 5001 standard.

Table 31-23. NZ7C3 Memory Map

| Nexus Register | Nexus Access Opcode | Read/Write | Read Address | Write Address |
|--|---------------------|------------|--------------|---------------|
| Client Select Control (CSC) ¹ | 0x1 | R | 0x02 | — |
| Port Configuration Register (PCR) ¹ | PCR_INDEX2 | R/W | — | — |
| Development Control 1 (DC1) | 0x2 | R/W | 0x04 | 0x05 |
| Development Control 2 (DC2) | 0x3 | R/W | 0x06 | 0x07 |
| Development Control 3 (DC3) | 0x4 | R/W | 0x08 | 0x09 |
| Development Control 4 (DC4) | 0x5 | R/W | 0x0A | 0x0B |
| Read/Write Access Control/Status (RWCS) | 0x7 | R/W | 0x0E | 0x0F |
| Read/Write Access Address (RWA) | 0x9 | R/W | 0x12 | 0x13 |

Table 31-23. NZ7C3 Memory Map (continued)

| Nexus Register | Nexus Access Opcode | Read/Write | Read Address | Write Address |
|---|---------------------|------------|--------------|---------------|
| Read/Write Access Data (RWD) | 0xA | R/W | 0x14 | 0x15 |
| Watchpoint Trigger (WT) | 0xB | R/W | 0x16 | 0x17 |
| Reserved | 0xC | R/W | 0x18 | 0x19 |
| Data Trace Control (DTC) | 0xD | R/W | 0x1A | 0x1B |
| Data Trace Start Address 1 (DTSA1) | 0xE | R/W | 0x1C | 0x1D |
| Data Trace Start Address 2 (DTSA2) | 0xF | R/W | 0x1E | 0x1F |
| Data Trace Start Address 3 (DTSA3) | 0x10 | R/W | 0x20 | 0x21 |
| Data Trace Start Address 4 (DTSA4) | 0x11 | R/W | 0x22 | 0x23 |
| Data Trace End Address 1 (DTEA1) | 0x12 | R/W | 0x24 | 0x25 |
| Data Trace End Address 2 (DTEA2) | 0x13 | R/W | 0x26 | 0x27 |
| Data Trace End Address 3 (DTEA3) | 0x14 | R/W | 0x28 | 0x29 |
| Data Trace End Address 4 (DTEA4) | 0x15 | R/W | 0x2A | 0x2B |
| Reserved | 0x16 – 0x2F | — | 0x28 – 0x5E | 0x29 – 0x5F |
| Development Status (DS) | 0x30 | R | 0x60 | — |
| Reserved | 0x31 | R/W | 0x62 | 0x63 |
| Overrun Control (OVCR) | 0x32 | R/W | 0x64 | 0x65 |
| Watchpoint Mask (WMSK) | 0x33 | R/W | 0x66 | 0x67 |
| Reserved | 0x34 | — | 0x68 | 0x69 |
| Program Trace Start Trigger Control (PTSTC) | 0x35 | R/W | 0x6A | 0x6B |
| Program Trace End Trigger Control (PTETC) | 0x36 | R/W | 0x6C | 0x6D |
| Data Trace Start Trigger Control (DTSTC) | 0x37 | R/W | 0x6E | 0x6F |
| Data Trace End Trigger Control (DTETC) | 0x38 | R/W | 0x70 | 0x71 |
| Reserved | 0x39 – 0x3F | — | 0x72 – 0x7E | 0x73 – 0x7F |

¹ The CSC and PCR registers are shown in this table as part of the Nexus programmer's model. They are only present at the top level Nexus controller in a multi-Nexus implementation, not in the Nexus 3 module. The CSC Register is readable through Nexus, but the PCR is shown for reference only here.

31.11.1 NZ7C3 Register Access via JTAG / OnCE

Access to Nexus3 register resources is enabled by loading a single instruction (ACCESS_AUX_TAP_ONCE) into the JTAGC instruction register (IR), and then loading the corresponding OnCE OCMD register with the NEXUS3_ACCESS instruction (see [Table 31-5](#)). For the NZ7C3 module, the OCMD value is 0b00_0111_1100.

After the ACCESS_AUX_TAP_ONCE instruction has been loaded, the JTAG/OnCE port allows tool/target communications with all Nexus3 registers according to the register map in [Table 31-23](#).

Reading/writing of a NZ7C3 register then requires two (2) passes through the data-scan (DR) path of the JTAG state machine (see 31.14.10).

1. The first pass through the DR selects the NZ7C3 register to be accessed by providing an index (see [Table 31-23](#)), and the direction (read/write). This is achieved by loading an 8-bit value into the JTAG data register (DR). This register has the following format:

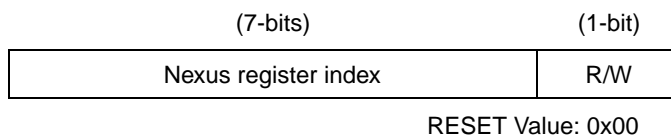

| | |
|-----------------------|---|
| Nexus Register Index: | Selected from values in Table 31-23 |
| Read/Write (R/W): | 0 Read 1 Write |

2. The second pass through the DR then shifts the data in or out of the JTAG port, lsb first.
 - a) During a read access, data is latched from the selected Nexus register when the JTAG state machine passes through the capture-DR state.
 - b) During a write access, data is latched into the selected Nexus register when the JTAG state machine passes through the update-DR state.

31.12 Ownership Trace

This section details the ownership trace features of the NZ7C3 module.

Ownership trace provides a macroscopic view, such as task flow reconstruction, when debugging software written in a high level (or object-oriented) language. It offers the highest level of abstraction for tracking operating system software execution. This is especially useful when the developer is not interested in debugging at lower levels.

31.12.1 Ownership Trace Messaging (OTM)

Ownership trace information is messaged via the auxiliary port using an ownership trace message (OTM). The e200z7 processor contains a Power Architecture Book E defined process ID register within the CPU.

The process ID register is updated by the operating system software to provide task/process ID information. The contents of this register are replicated on the pins of the processor and connected to Nexus. The process ID register value can be accessed using the **mfspr/mtspr** instructions. Please see the *e200z7 PowerPC™ Core Reference Manual* for more details on the process ID register.

The only condition that causes an ownership trace message occurs when the OTR register is updated or process ID register by the e200z7 processor, the data is latched within Nexus, and is messaged out via the auxiliary port, allowing development tools to trace ownership flow.

Ownership trace information is messaged out in the following format:

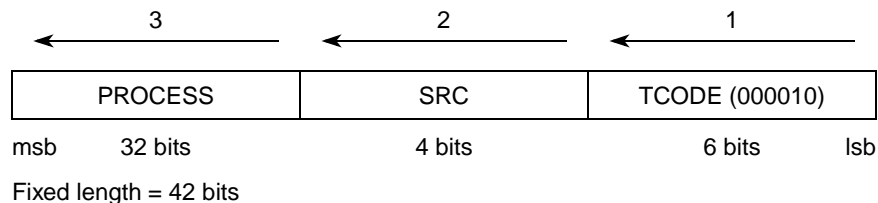

Figure 31-14. Ownership Trace Message Format

31.12.2 OTM Error Messages

An error message occurs when a new message cannot be queued due to the message queue being full. The FIFO discards incoming messages until the queue the queue is completely empty. After it empties, an error message is queued. The error encoding indicate the message types denied service to the queue while the FIFO was emptying.

If an OTM message only attempts to enter the queue while the queue is emptying, the error message incorporates the OTM error encoding (00000) only. If OTM and either BTM or DTM messages attempt to enter the queue, the error message incorporates the OTM and (program or data) trace error encoding (00111). If a watchpoint also attempts to enter the queue while the FIFO is emptying, then the error message incorporates error encoding (01000).

NOTE

The OVC bits within the DC1 register can be set to delay the CPU to alleviate (but not eliminate) potential overrun situations.

Error information is messaged out in the following format (see [Table 31-19](#)):

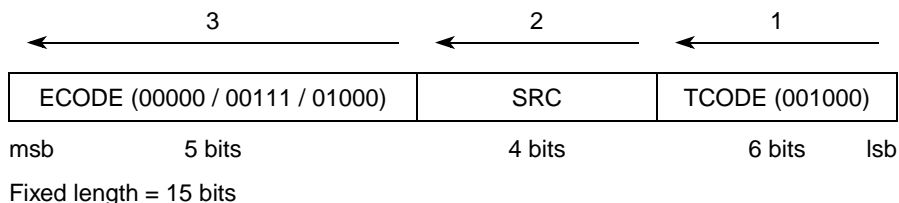

Figure 31-15. Error Message Format

31.12.3 OTM Flow

Ownership trace messages are generated when the operating system writes to the e200z7 process ID register or the memory mapped ownership trace register.

The following flow describes the OTM process:

1. The process ID register is a system control register. It is internal to the e200z7 processor and can be accessed by using PPC instructions **mtspr** and **mfspir**. The contents of this register are replicated on the pins of the processor and connected to Nexus.
2. OTR/process ID register reads do not cause ownership trace messages to be transmitted by the NZ7C3 module.

3. If the periodic OTM message counter expires (after 255 queued messages without an OTM), an OTM is sent using the latched data from the previous OTM or process ID register write.

31.13 Program Trace

This section details the program trace mechanism supported by NZ7C3 for the PXR40 processor. Program trace is implemented via branch trace messaging (BTM) as per the Class 3 IEEE-ISTO 5001-2011 standard definition. Branch trace messaging for e200z7 processors is accomplished by snooping the e200z7 virtual address bus (between the CPU and MMU), attribute signals, and CPU status.

31.13.1 Branch Trace Messaging (BTM)

Traditional branch trace messaging facilitates program trace by providing the following types of information:

- Messages generated for direct branches that were taken indicate the number of sequential instructions executed since the last branch or exception. Branches not taken (direct or indirect) are not counted as sequential instructions.
- Messages generated for indirect branches and exceptions that were taken indicate:
 - Number of sequential instructions executed since the last branch that was taken
 - Exception with the unique portion of the branch target address or exception vector address
- History field in the branch and predicate instructions that can generate the following messages for program trace:
 - Number of sequential instructions executed since the last indirect branch was taken, as well as the unique portion of the indirect branch address
 - Number of sequential instructions executed since the last exception was processed, as well as the unique portion of the exception vector address
 - Number of sequential instructions executed since the last predicate instruction was taken
 - History field in the branch and predicate instruction unique to the branch target address or exception vector address. Each bit in the history field represents a direct branch or predicated instruction where a value of one (1) indicates taken, and a value of zero (0) indicates not taken. Certain instructions (**evsel**) generate a pair of predicate bits which are both reported as consecutive bits in the history field.

31.13.1.1 e200z7 Indirect Branch Message Instructions (Power Architecture Book E)

Table 31-24 shows the types of instructions and events which cause indirect branch messages or branch history messages to be encoded.

Table 31-24. Indirect Branch Message Sources

| Source of Indirect Branch Message | Instructions |
|---|----------------------------|
| Taken branch relative to a register value | bcctr, bcctrl, bclr, bclrl |

Table 31-24. Indirect Branch Message Sources (continued)

| Source of Indirect Branch Message | Instructions |
|-------------------------------------|----------------|
| System call / trap exceptions taken | sc, tw, twi |
| Return from interrupts / exceptions | rfi, rfc, rfdi |

31.13.1.2 e200z7 Direct Branch Message Instructions (Power Architecture Book E)

Table 31-25 shows the instruction types that cause direct branch messages, or toggle a bit in the instruction history buffer in a resource full message or branch history message before it is sent out.

Table 31-25. Direct Branch Message Sources

| Source of Direct Branch Message | Instructions |
|----------------------------------|------------------------------------|
| Taken direct branch instructions | b, ba, bl, bla, bc, bca, bcl, bcla |
| Instruction synchronize | isync |

31.13.1.3 BTM Using Branch History Messages

Traditional BTM messaging can accurately track the number of sequential instructions between branches, but cannot accurately indicate which instructions were conditionally executed, and which were not.

Branch history messaging solves this problem by providing a predicated instruction history field in each indirect branch message. Each bit in the history represents a predicated instruction or direct branch. A value of one (1) indicates the conditional instruction was executed or the direct branch was taken. A value of zero (0) indicates the conditional instruction was not executed or the direct branch was not taken. Certain instructions (**evsel**) generate a pair of predicate bits which are both reported as consecutive bits in the history field.

Branch history messages solve predicated instruction tracking and save bandwidth since only indirect branches cause messages to be queued.

31.13.1.4 BTM Using Traditional Program Trace Messages

Based on the PTM bit in the DC register (DC[PTM]), program tracing can use:

- Branch history messages (DC[PTM] = 1); or
- Traditional direct and indirect branch messages (DC[PTM] = 0)

Branch history saves bandwidth and keeps consistency between methods of program trace, yet can lose temporal order between BTM messages and other types of messages. Since direct branches are not messaged, but are instead included in the history field of the indirect branch history message, other types of messages can enter the FIFO between branch history messages. The development tool cannot determine the order of “events” that occurred for direct branches by the order in which messages are sent out.

Traditional BTM messages maintain their temporal ordering because each event that queues a message to the FIFO is processed and sent in the order it was generated, and the message order is maintained when it is transmitted.

31.13.2 BTM Message Formats

The e200z7 Nexus3 module supports three types of traditional BTM messages—direct, indirect, and synchronization messages. It supports two types of branch history BTM messages—indirect branch history, and indirect branch history with synchronization messages. Debug status messages and error messages are also supported.

31.13.2.1 Indirect Branch Messages (History)

Indirect branches include all taken branches whose destination is determined at run time, interrupts and exceptions. If DC[PTM] is set, indirect branch information is messaged out in the following format:

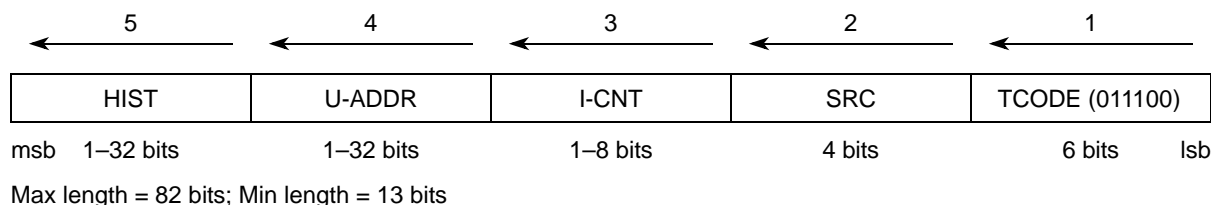

Figure 31-16. Indirect Branch Message (History) Format

31.13.2.2 Indirect Branch Messages (Traditional)

If DC[PTM] is cleared, indirect branch information is messaged out in the following format:

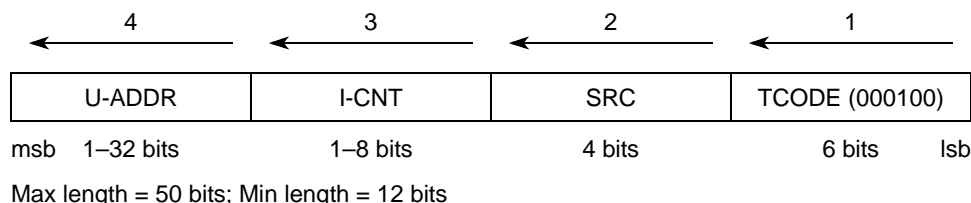

Figure 31-17. Indirect Branch Message Format

31.13.2.3 Direct Branch Messages (Traditional)

Direct branches (conditional or unconditional) are all taken branches whose destination is fixed in the instruction opcode. Direct branch information is messaged out in the following format:

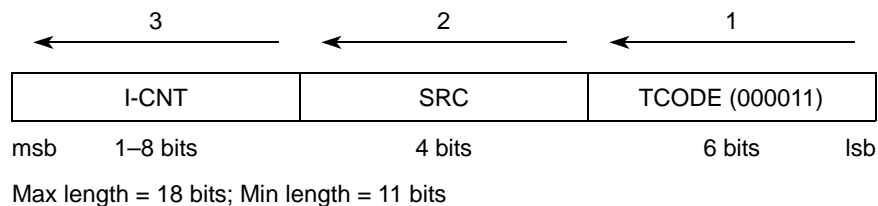

Figure 31-18. Direct Branch Message Format

NOTE

When DC[PTM] is set, direct branch messages are not transmitted. Instead, each direct branch or predicated instruction toggles a bit in the history buffer.

31.13.2.4 Resource Full Messages

The resource full message is used in conjunction with the branch history messages. The resource full message is generated when the internal branch/predicate history buffer is full, or if the BTM Instruction sequence counter (I-CNT) overflows. If synchronization is needed at the time this message is generated, the synchronization is delayed until the next branch trace message that is not a resource full message.

The current value of the history buffer is transmitted as part of the resource full message. This information can be concatenated by the tool with the branch/predicate history information from subsequent messages to obtain the complete branch history for a message. The internal history value is reset by this message, and the I-CNT value is reset as a result of a bit being added to the history buffer.

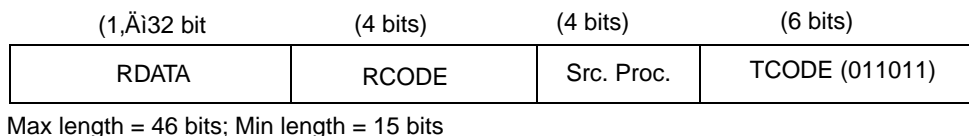

Figure 31-19. Resource Full Message Format

31.13.2.5 Debug Status Messages

NOTE

Debug Status Messages (DSMs) are enabled if the Nexus module is enabled.

Debug status messages report low power mode and debug status. Entering/exiting debug mode as well as entering a low power mode triggers a debug status message.

Debug status information is sent out in the following format:

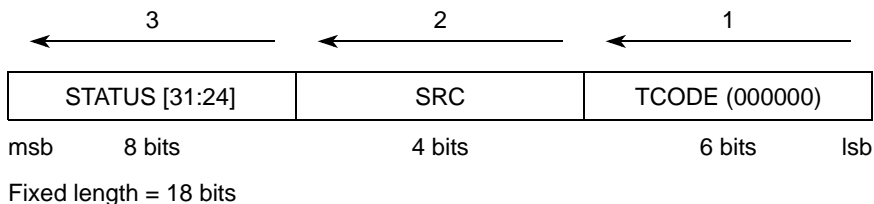

Figure 31-20. Debug Status Message Format

31.13.2.6 Program Correlation Messages

Program correlation messages are used to correlate events to the program flow that are not necessarily associated with the instruction stream. To maintain accurate instruction tracing information when entering debug mode or a CPU low power mode (where tracing can be disabled), this message is sent upon entry into one of these two modes and includes the instruction count and branch history. Program correlation is messaged out in the following format:

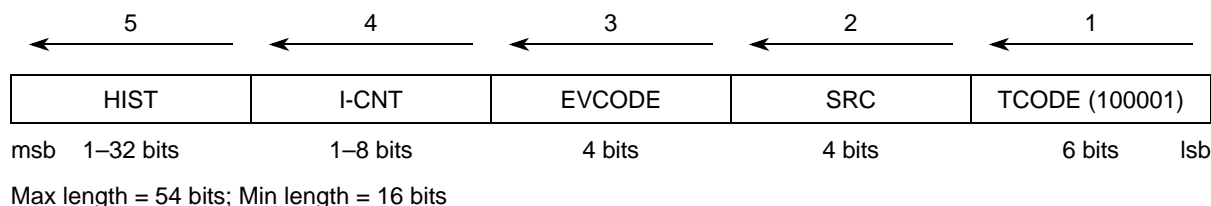

Figure 31-21. Program Correlation Message Format

31.13.2.7 BTM Overflow Error Messages

An error message occurs when a new message cannot be queued because the message queue is full. The FIFO discards incoming messages until the queue is completely empty. After it is empty, an error message is queued. The error encoding indicates which message types were denied queueing while the FIFO was emptying.

If only a program trace message attempts to enter the queue while it is being emptied, the error message incorporates the program trace only error encoding (00001). If both OTM and program trace messages attempt to enter the queue, the error message incorporates the OTM and program trace error encoding (00111). If a watchpoint also attempts to be queued while the FIFO is being emptied, then the error message incorporates error encoding (01000).

NOTE

The OVC bits within the DC1 register can be set to delay the CPU to alleviate (but not eliminate) potential overrun situations.

Error information is messaged out in the following format:

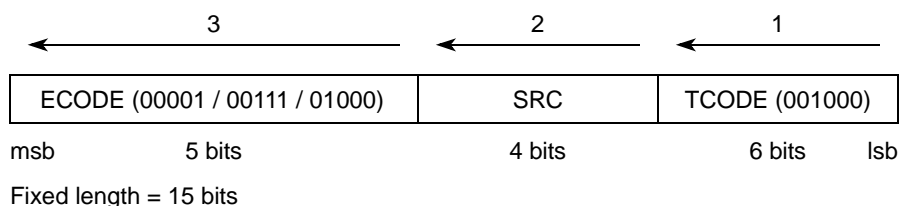

Figure 31-22. Error Message Format

31.13.3 Program Trace Synchronization Messages

A program trace direct/indirect branch with sync message is messaged via the auxiliary port (provided program trace is enabled) for the following conditions (see [Table 31-26](#)):

- Initial program trace message upon the first direct/indirect branch after exit from system reset or whenever program trace is enabled

- Upon direct/indirect branch after returning from a CPU low power state
- Upon direct/indirect branch after returning from debug mode
- Upon direct/indirect branch after occurrence of queue overrun (can be caused by any trace message), provided program trace is enabled
- Upon direct/indirect branch after the periodic program trace counter has expired indicating 255 *without-sync* program trace messages have occurred since the last *with-sync* message occurred
- Upon direct/indirect branch after assertion of the event in (EVTI) pin if the EIC bits within the DC1 register have enabled this feature
- Upon direct/indirect branch after the sequential instruction counter has expired indicating 255 instructions have occurred between branches
- Upon direct/indirect branch after a BTM message was lost due to an attempted access to a secure memory location.
- Upon direct/indirect branch after a BTM message was lost due to a collision entering the FIFO between the BTM message and either a watchpoint message or an ownership trace message

If the NZ7C3 module is enabled at reset, a EVTI assertion initiates a program trace direct/indirect branch with sync message (if program trace is enabled) upon the first direct/indirect branch. The format for program trace direct/indirect branch with sync messages is as follows:

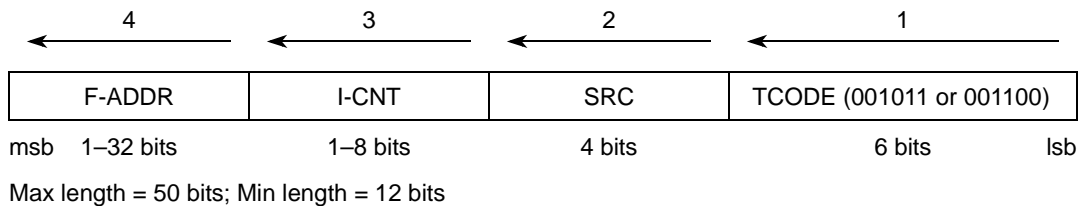

Figure 31-23. Direct/Indirect Branch with Sync Message Format

The formats for program trace direct/indirect branch with sync. messages and indirect branch history with sync. messages are as follows:

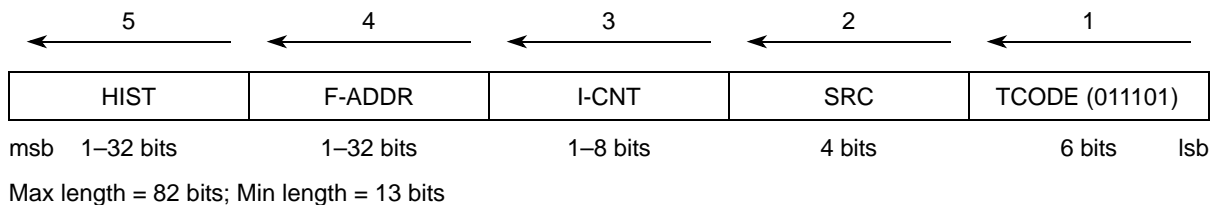

Figure 31-24. Indirect Branch History with Sync. Message Format

Exception conditions that result in program trace synchronization are summarized in [Table 31-26](#).

Table 31-26. Program Trace Exception Summary

| Exception Condition | Exception Handling |
|-----------------------|--|
| System Reset Negation | At the negation of JTAG reset (JCOMP), queue pointers, counters, state machines, and registers within the NZ7C3 module are reset. Upon the first branch out of system reset (if program trace is enabled), the first program trace message is a direct/indirect branch with sync. message. |

Table 31-26. Program Trace Exception Summary (continued)

| Exception Condition | Exception Handling |
|---------------------------------------|---|
| Program Trace Enabled | The first program trace message (after program trace has been enabled) is a synchronization message. |
| Exit from Low Power/Debug | Upon exiting from the low power or debug modes, the next direct/indirect branch is converted to a direct/indirect branch with sync. message. |
| Queue Overrun | An error message occurs when a new message cannot be queued due to the message queue being full. The FIFO discards messages until the queue is completely empty. After it is empty, an error message is queued. The error encoding indicates the message types denied queueing while the FIFO was emptying. The next BTM message in the queue is a direct/indirect branch with sync. message. |
| Periodic Program Trace Sync. | A forced synchronization occurs periodically after 255 program trace messages have been queued. A direct/indirect branch with sync. message is queued. The periodic program trace message counter then resets. |
| Event In | If the Nexus module is enabled, an EVT1 assertion initiates a direct/indirect branch with sync. message upon the next direct/indirect branch (if program trace is enabled and the EIC bits of the DC1 register have enabled this feature). |
| Sequential Instruction Count Overflow | When the sequential instruction counter reaches its maximum count (up to 255 sequential instructions can be executed), a forced synchronization occurs. The sequential counter then resets. A program trace direct/indirect branch with sync.message is queued upon execution of the next branch. |
| Attempted Access to Secure Memory | For devices which implement security, any attempt to branch to secure memory locations temporarily disables program trace and cause the corresponding BTM to be lost. The following direct/indirect branch queues a direct/indirect branch with sync. message. The count value within this message can be inaccurate since re-enabling program trace does not guarantee alignment on an instruction boundary. |
| Collision Priority | All messages have the following priority: WPM → OTM → BTM → DTM. A BTM message which attempts to enter the queue at the same time as a watchpoint message or ownership trace message is lost. An error message is sent indicating the BTM was lost. The following direct/indirect branch queues a direct/indirect branch with sync. message. The count value within this message reflects the number of sequential instructions executed after the last successful BTM message was generated. This count includes the branch which did not generate a message due to the collision. |

31.14 BTM Operation

31.14.1 Enabling Program Trace

Both types of branch trace messaging can be enabled in one of two ways:

- Setting the TM field of the DC1 register to enable program trace (DC1[TM])
- Using the PTS field of the WT register to enable program trace on watchpoint hits (e200z7 watchpoints are configured within the CPU)

31.14.2 Relative Addressing

The relative address feature is compliant with the IEEE-ISTO 5001-2011 standard recommendations, and is designed to reduce the number of bits transmitted for addresses of indirect branch messages.

The address transmitted is relative to the target address of the instruction which triggered the previous indirect branch (or sync) message. It is generated by XOR'ing the new address with the previous address, and then using only the results up to the most significant 1 in the result. To recreate this address, an XOR of the (most-significant 0-padded) message address with the previously decoded address gives the current address.

Previous address (A1) = 0x0003FC01, New address (A2) = 0x0003F365

| |
|---|
| <p>Message Generation:</p> <p>A1 = 0000 0000 0000 0011 1111 1100 0000 0001 A2 = 0000 0000 0000 0011 1111 0011 0110 0101</p> <p>$A1 \oplus A2 = 0000\ 0000\ 0000\ 0000\ 0000\ 1111\ 0110\ 0100$</p> <p>Address Message (M1) = 1111 0110 0100</p> <p>Address Re-creation:</p> <p>$A1 \oplus M1 = A2$ A1 = 0000 0000 0000 0011 1111 1100 0000 0001 M1 = 0000 0000 0000 0000 0000 1111 0110 0100 <hr/> A2 = 0000 0000 0000 0011 1111 0011 0110 0101</p> |
|---|

Figure 31-25. Relative Address Generation and Re-creation

31.14.3 Branch and Predicate Instruction History (HIST)

If DC[PTM] is set, BTM messaging uses the branch history format. The branch history (HIST) packet in these messages provides a history of direct branch execution used for reconstructing the program flow. This packet is implemented as a left-shifting shift register. The register is always pre-loaded with a value of one (1). This bit acts as a stop bit so that the development tools can determine which bit is the end of the history information. The pre-loaded bit itself is not part of the history, but is transmitted with the packet.

A value of one (1) is shifted into the history buffer on a taken branch (condition or unconditional) and on any instruction whose predicate condition executed as true. A value of zero (0) is shifted into the history buffer on any instruction whose predicate condition executed as false as well as on branches not taken. This includes indirect as well as direct branches were not taken. For the **evsel** instruction, two bits are shifted in, corresponding to the low element (shifted in first) and the high element (shifted in second) conditions.

31.14.4 Sequential Instruction Count (I-CNT)

The I-CNT packet, is present in all BTM messages. For traditional branch messages, I-CNT represents the number of sequential instructions, or non-taken branches in between direct/indirect branch messages.

For branch history messages, I-CNT represents the number of instructions executed since the last taken/non-taken direct branch, last taken indirect branch or exception. Not taken indirect branches are considered sequential instructions and cause the instruction count to increment. I-CNT also represents the number of instructions executed since the last predicate instruction.

The sequential instruction counter overflows when its value reaches 255. The next BTM message is converted to a synchronization type message.

31.14.5 Program Trace Queueing

NZ7C3 implements a message queue. Messages that enter the queue are transmitted via the auxiliary pins in the order in which they are queued.

NOTE

If multiple trace messages must be queued at the same time, Watchpoint Messages have the highest priority (WPM → OTM → BTM → DTM).

31.14.5.1 Program Trace Timing Diagrams

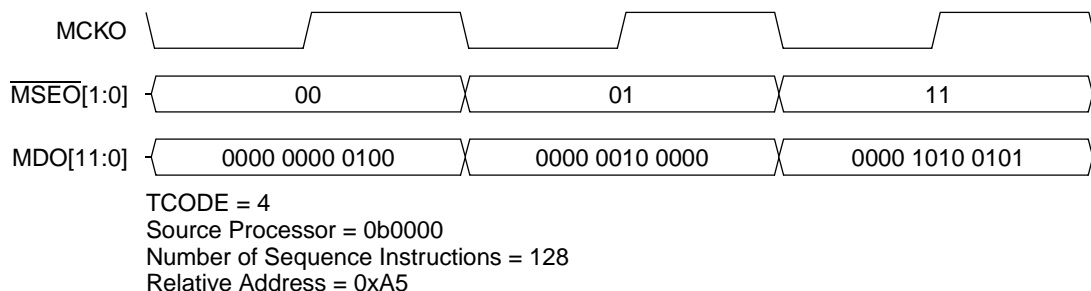

Figure 31-26. Program Trace (MDO = 12)—Indirect Branch Message (Traditional)

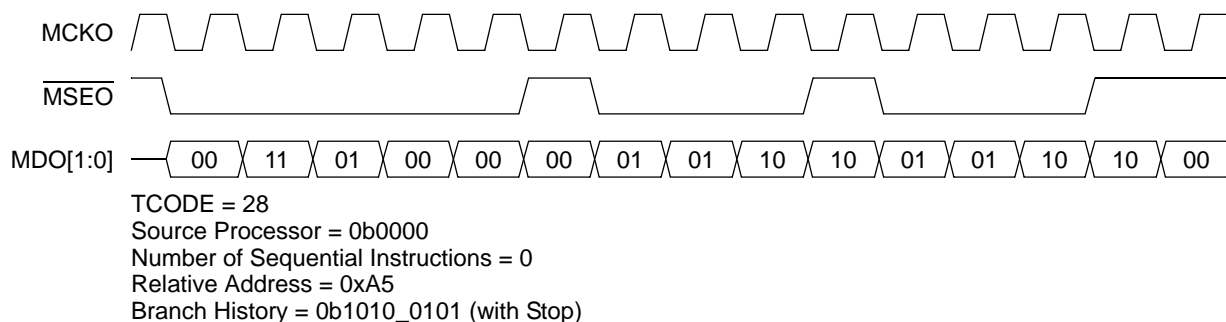

Figure 31-27. Program Trace (MDO = 2)—Indirect Branch Message (History)

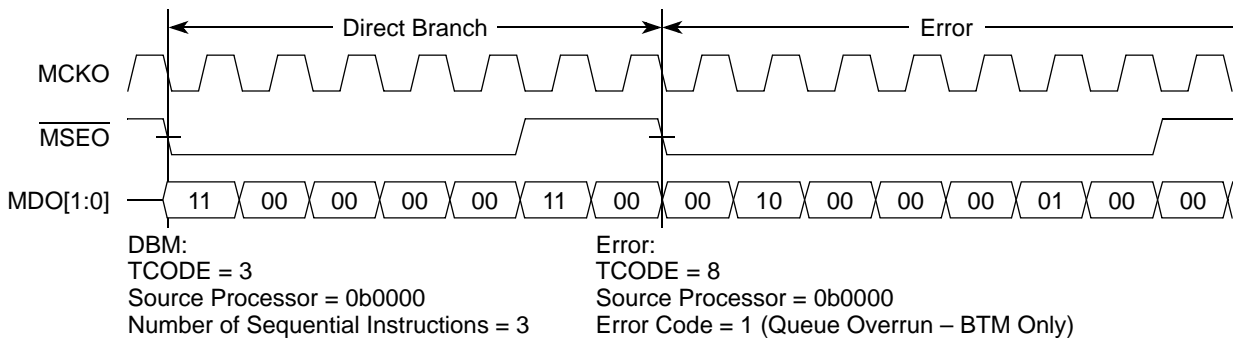

Figure 31-28. Program Trace—Direct Branch (Traditional) and Error Messages

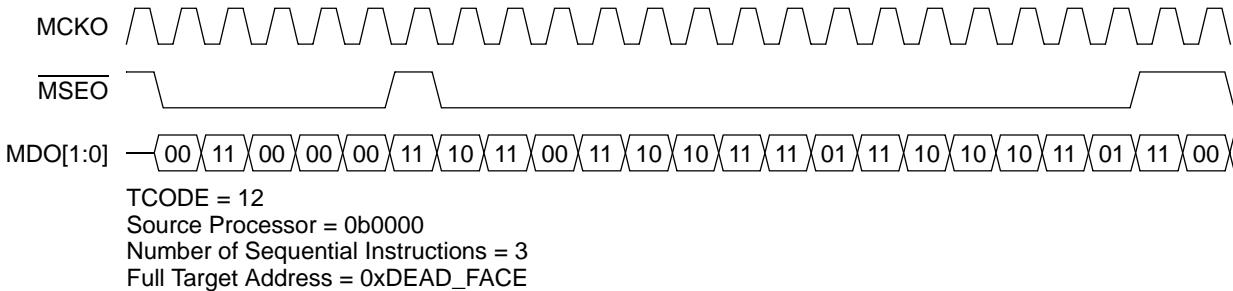

Figure 31-29. Program Trace—Indirect Branch with Sync. Message

31.14.6 Data Trace

This section deals with the data trace mechanism supported by the NZ7C3 module. Data trace is implemented via data write messaging (DWM) and data read messaging (DRM), as per the IEEE-ISTO 5001-2011 standard.

31.14.6.1 Data Trace Messaging (DTM)

Data trace messaging for e200z7 is accomplished by snooping the e200z7 virtual data bus (between the CPU and MMU), and storing the information for qualifying accesses (based on enabled features and matching target addresses). The NZ7C3 module traces all data access that meet the selected range and attributes.

NOTE

Data trace is only performed on the e200z7 virtual data bus. This allows for data visibility for the incorporated data cache. Only e200z7 CPU initiated accesses are traced. No DMA accesses to the NXDM system bus are traced.

Data trace messaging can be enabled in one of two ways:

- Setting the TM field of the DC1 register to enable data trace (DC1[TM]).
- Using WT[DTS] to enable data trace on watchpoint hits (e200z7 watchpoints are configured within the Nexus1 module)

31.14.6.2 DTM Message Formats

The Nexus3 module supports five types of DTM messages: data write, data read, data write synchronization, data read synchronization and error messages.

31.14.6.2.1 Data Write Messages

The data write message contains the data write value and the address of the write access, relative to the previous data trace message. Data write message information is messaged out in the following format:

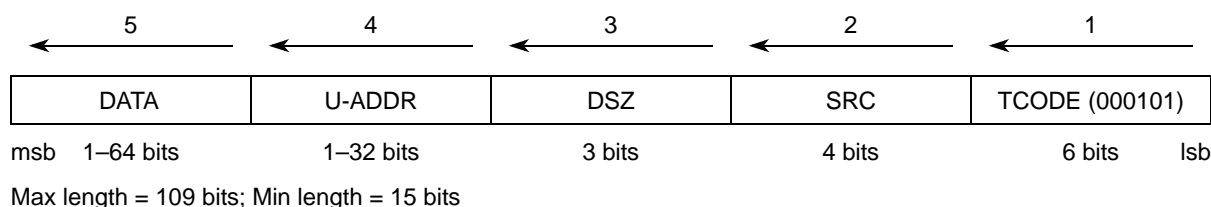

Figure 31-30. Data Write Message Format

31.14.6.2.2 Data Read Messages

The data read message contains the data read value and the address of the read access, relative to the previous data trace message. Data read message information is messaged out in the following format:

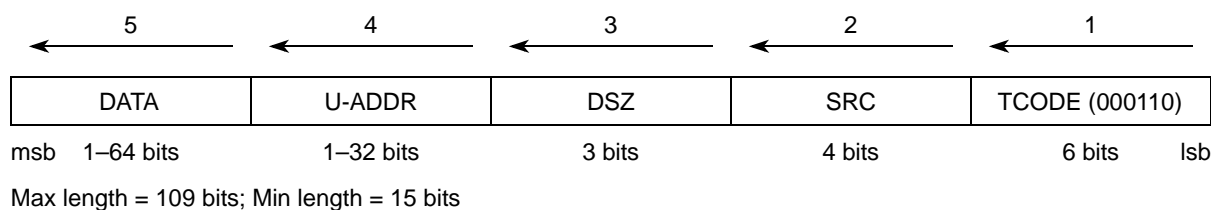

Figure 31-31. Data Read Message Format

NOTE

For the e200z7 based CPU, the doubleword encoding (data size = 0b000) indicates a doubleword access and sends out as a single data trace message with a single 64-bit data value.

31.14.6.2.3 DTM Overflow Error Messages

An error message occurs when the next message is denied service because the message queue is full. The FIFO discards all incoming messages until the queue is completely empty. After it is empty, an error message is queued that indicates the message types denied into the queue while the FIFO is emptying.

If a data trace message only attempts to enter the queue while it is emptying, the error message incorporates the data trace only error encoding (00010). If both OTM and data trace messages attempt to enter the queue, the error message incorporates the OTM and data trace error encoding (00111). If a watchpoint also attempts to be queued while the FIFO is being emptied, then the error message incorporates error encoding (01000).

NOTE

The OVC bits within the DC1 register can be set to delay the CPU to alleviate (but not eliminate) potential overrun situations.

Error information is messaged out in the following format:

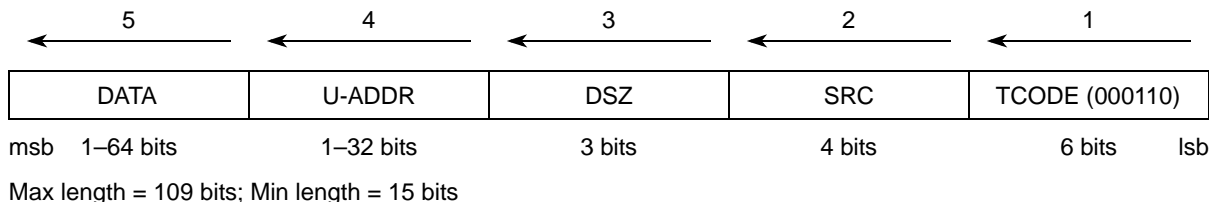

Figure 31-32. Error Message Format

31.14.6.2.4 Data Trace Synchronization Messages

A data trace write/read with sync. message is messaged via the auxiliary port (provided data trace is enabled) for the following conditions (see [Table 31-27](#)):

- Initial data trace message after exit from system reset or whenever data trace is enabled
- Upon exiting debug mode
- After occurrence of queue overrun (can be caused by any trace message), provided data trace is enabled
- After the periodic data trace counter has expired indicating 255 *without-sync* data trace messages have occurred since the last *with-sync* message occurred
- Upon assertion of the event in (EVTI) pin, the first data trace message is a synchronization message if the EIC bits of the DC1 register have enabled this feature
- Upon data trace write/read after the previous DTM message was lost due to an attempted access to a secure memory location
- Upon data trace write/read after the previous DTM message was lost due to a collision entering the FIFO between the DTM message and any of the following: watchpoint message, ownership trace message, or branch trace message

Data trace synchronization messages provide the full address (without leading zeros) and insure that development tools fully synchronize with data trace regularly. Synchronization messages provide a reference address for subsequent data messages, in which only the unique portion of the data trace address is transmitted. The format for data trace write/read with sync. messages is as follows:

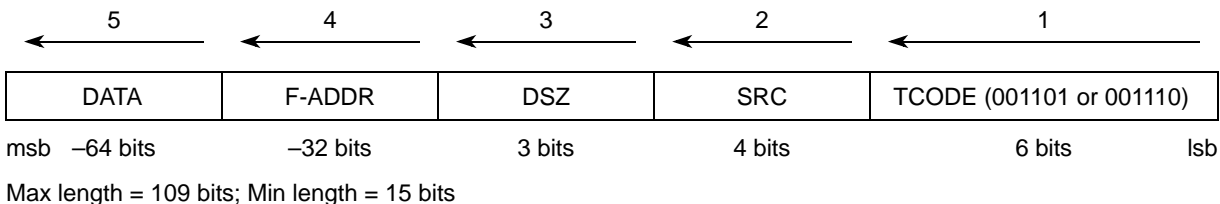

Figure 31-33. Data Write/Read with Sync. Message Format

Exception conditions that result in data trace synchronization are summarized in [Table 31-27](#).

Table 31-27. Data Trace Exception Summary

| Exception Condition | Exception Handling |
|-----------------------------------|---|
| System Reset Negation | At the negation of JTAG reset (JCOMP), queue pointers, counters, state machines, and registers within the NZ7C3 module are reset. If data trace is enabled, the first data trace message is a data write/read with sync. message. |
| Data Trace Enabled | The first data trace message (after data trace has been enabled) is a synchronization message. |
| Exit from Low Power/Debug | Upon exiting from low power or debug modes, the next data trace message is converted to a data write/read with sync. message. |
| Queue Overrun | An error message occurs when a new message cannot be queued due to a full message queue. The FIFO discards messages until it has completely emptied the queue. After the queue is empty, an error message is queued that indicates the message types denied queuing while the FIFO was emptying. The next DTM message in the queue is a data write/read with sync. message. |
| Periodic Data Trace Sync. | A forced synchronization occurs periodically after 255 data trace messages have been queued. A data write/read with sync. message is queued. The periodic data trace message counter then resets. |
| Event In | If the Nexus module is enabled, a EVTI assertion initiates a data trace write/read with sync. message upon the next data write/read (if data trace is enabled and the EIC bits of the DC1 register have enabled this feature). |
| Attempted Access to Secure Memory | For devices which implement security, any attempted read or write to secure memory locations temporarily disables data trace and loses the DTM. A subsequent read/write queues a data trace read/write with sync. message. |
| Collision Priority | All messages have the following priority: WPM → OTM → BTM → DTM. A DTM message which attempts to enter the queue at the same time as a watchpoint message or ownership trace message or branch trace message can be lost. A subsequent read/write queues a data trace read/write with sync. message. |

31.14.6.3 DTM Operation

31.14.6.3.1 DTM Queuing

NZ7C3 implements a message queue for DTM messages. Messages that enter the queue are transmitted via the auxiliary pins in the order in which they are queued.

NOTE

If multiple trace messages must be queued at the same time, watchpoint messages have the highest priority (WPM → OTM → BTM → DTM).

31.14.6.3.2 Relative Addressing

The relative address feature is compliant with the IEEE-ISTO 5001-2011 standard recommendations, and is designed to reduce the number of bits transmitted for addresses of data trace messages. See [Section 31.14.2, Relative Addressing](#) for details.

31.14.6.3.3 Data Trace Windowing

Data write/read messages are enabled via the RWT1(2) field in the data trace control register (DTC) for each DTM channel. Data trace windowing is achieved via the address range defined by the DTEA and DTSA registers and by the RC1(2) field in the DTC. All e200z7 initiated read/write accesses which fall inside or outside these address ranges, as programmed, are candidates to be traced.

31.14.6.3.4 Data Access/Instruction Access Data Tracing

The Nexus3 module is capable of tracing both instruction access data or data access data. Each trace window can be configured for either type of data trace by setting the DI1(2) field within the data trace control register for each DTM channel.

31.14.6.3.5 e200z7 Bus Cycle Special Cases

Table 31-28. e200z7 Bus Cycle Cases

| Special Case | Action |
|---|--|
| e200z7 bus cycle aborted | Cycle ignored |
| e200z7 bus cycle with data error (\overline{TEA}) | Data Trace Message discarded |
| e200z7 bus cycle completed without error | Cycle captured & transmitted |
| e200z7 bus cycle initiated by NZ7C3 | Cycle ignored |
| e200z7 bus cycle is an instruction fetch | Cycle ignored |
| e200z7 bus cycle accesses misaligned data (across 64-bit boundary)—both 1st and 2nd transactions within data trace range | 1st and 2nd cycle captured, and 2 DTM's transmitted (see Note) |
| e200z7 bus cycle accesses misaligned data (across 64-bit boundary)—1st transaction within data trace range; 2nd transaction out of data trace range | 1st cycle captured and transmitted; 2nd cycle ignored |
| e200z7 bus cycle accesses misaligned data (across 64-bit boundary)—1st transaction out of data trace range; 2nd transaction within data trace range | 1st cycle ignored; 2nd cycle capture and transmitted |

NOTE

For misaligned accesses (crossing 64-bit boundary), the access is broken into two accesses. If both accesses are within the data trace range, two DTMs are sent: one with a size encoding indicating the size of the original access (a word), and one with a size encoding for the portion which crossed the boundary (3 bytes).

NOTE

An STM to the cache's store buffer within the data trace range initiates a DTM message. If the corresponding memory access causes an error, a checkstop condition occurs. The debug/development tool must use this indication to invalidate the previous DTM.

31.14.6.4 Data Trace Timing Diagrams (Eight MDO Configuration)

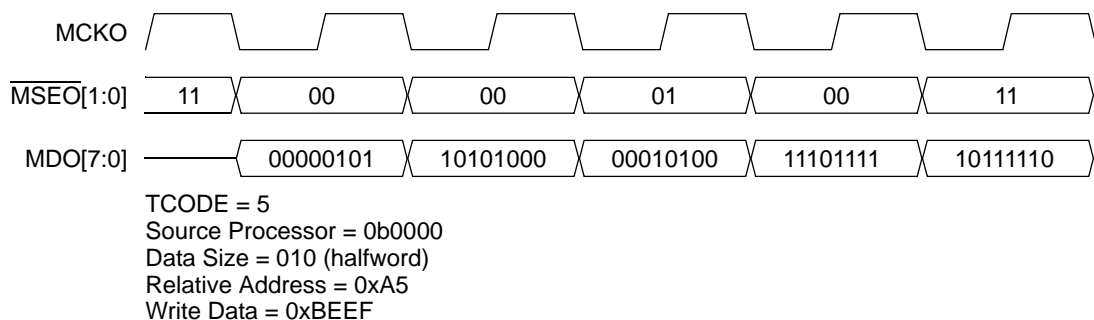

Figure 31-34. Data Trace—Data Write Message

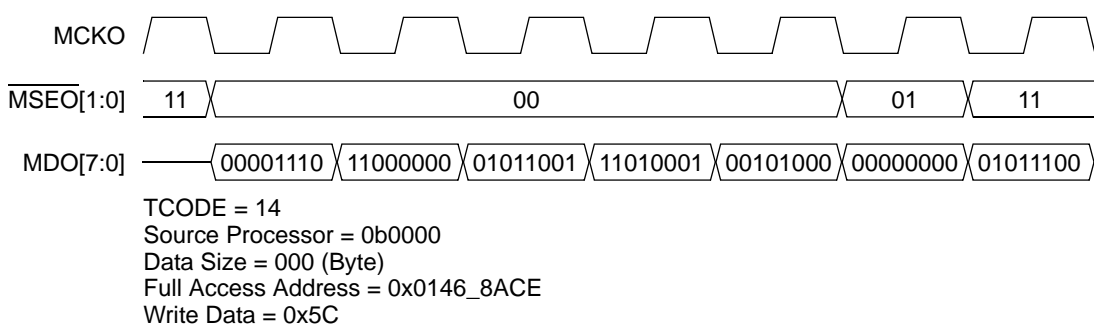

Figure 31-35. Data Trace—Data Read with Sync Message

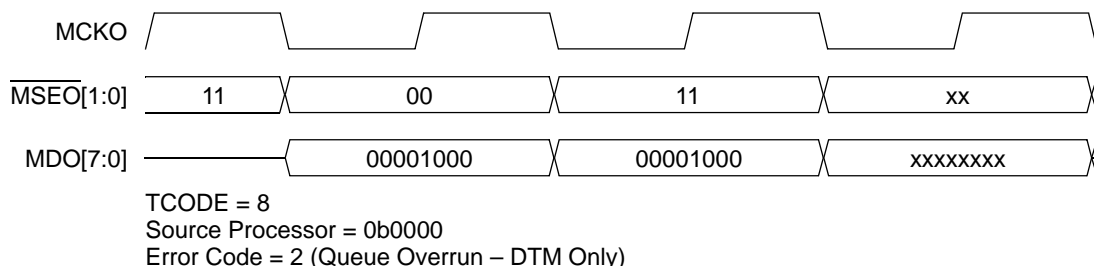

Figure 31-36. Error Message (Data Trace only encoded)

31.14.7 Watchpoint Support

This section details the watchpoint features of the NZ7C3 module.

31.14.7.1 Overview

The NZ7C3 module provides watchpoint messaging via the auxiliary pins, as defined by the IEEE-ISTO 5001-2011 standard.

NZ7C3 is not compliant with Class4 breakpoint/watchpoint requirements defined in the standard. The breakpoint/watchpoint control register is not implemented.

31.14.7.2 Watchpoint Messaging

Enabling watchpoint messaging is done by setting the watchpoint enable bit in the DC1 register. Setting the individual watchpoint sources is supported through the e200z7 Nexus1 module. The e200z7 Nexus1 module is capable of setting multiple address and/or data watchpoints. Please see the e200z7 Core Reference Manual for more information on watchpoint initialization.

When these watchpoints occur, a watchpoint event signal from the Nexus1 module causes a message to be sent to the queue to be messaged out. This message includes the watchpoint number indicating which watchpoint caused the message.

The occurrence of any of the e200z7 defined watchpoints can be programmed to assert the event out $\overline{\text{EVTO}}$ pin for one period of the output clock (MCKO).

Watchpoint information is messaged out in the following format:

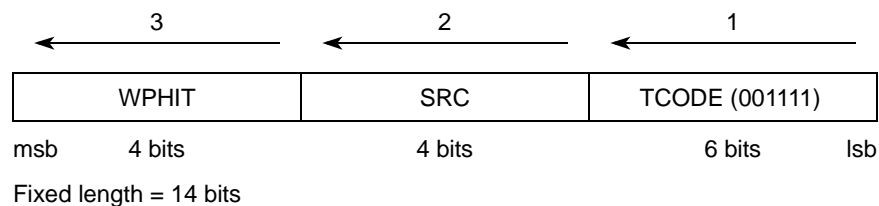

Figure 31-37. Watchpoint Message Format.

Table 31-29. Watchpoint Source Encoding

| Watchpoint Source (8 bits) | Watchpoint Description |
|----------------------------|--|
| 00000001 | e200z7 Watchpoint #0 (IAC1 from Nexus1) |
| 00000010 | e200z7 Watchpoint #1 (IAC2 from Nexus1) |
| 00000100 | e200z7 Watchpoint #2 (IAC3 from Nexus1) |
| 00001000 | e200z7 Watchpoint #3 (IAC4 from Nexus1) |
| 00010000 | e200z7 Watchpoint #4 (DAC1 from Nexus1) |
| 00100000 | e200z7 Watchpoint #5 (DAC2 from Nexus1) |
| 01000000 | e200z7 Watchpoint #6 (DCNT1 from Nexus1) |
| 10000000 | e200z7 Watchpoint #7 (DCNT2 from Nexus1) |

31.14.7.3 Watchpoint Error Message

An error message occurs when a new message cannot be queued due to the message queue being full. The FIFO discards messages until it has completely emptied the queue. After it is emptied, an error message is queued. The error encoding indicates the types of messages that attempted to be queued while the FIFO was being emptied.

If only a watchpoint message attempts to enter the queue while it is being emptied, the error message incorporates the watchpoint only error encoding (00110). If an OTM and/or program trace and/or data trace message also attempts to enter the queue while it is being emptied, the error message incorporates error encoding (01000).

NOTE

The OVC bits within the DC1 register can be set to delay the CPU to alleviate (but not eliminate) potential overrun situations.

Error information is messaged out in the following format (see [Table 31-19](#)):

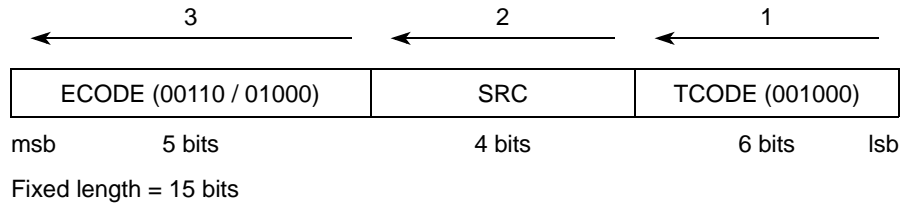

Figure 31-38. Error Message Format

31.14.7.4 Watchpoint Timing Diagram (Two MDO and One MSEO Configuration)

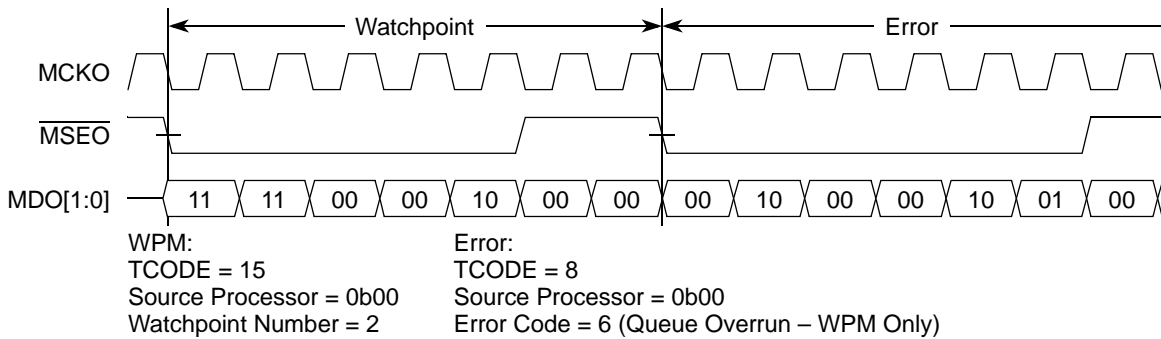

Figure 31-39. Watchpoint Message and Watchpoint Error Message

31.14.8 NZ7C3 Read/Write Access to Memory-Mapped Resources

The read/write access feature allows access to memory-mapped resources via the JTAG/OnCE port. The read/write mechanism supports single as well as block reads and writes to e200z7 system bus resources.

The NZ7C3 module is capable of accessing resources on the e200z7 system bus, with multiple configurable priority levels. Memory-mapped registers and other non-cached memory can be accessed via the standard memory map settings.

All accesses are setup and initiated by the read/write access control/status register (RWCS), as well as the read/write access address (RWA) and read/write access data registers (RWD).

Using the read/write access registers (RWCS/RWA/RWD), memory-mapped e200z7 system bus resources can be accessed through NZ7C3. The following subsections describe the steps which are required to access memory-mapped resources.

NOTE

Read/write access can only access memory mapped resources when system reset is de-asserted.

Misaligned accesses are NOT supported in the e200z7 Nexus3 module.

31.14.8.1 Single Write Access

1. Initialize the read/write access address register (RWA) through the access method outlined in [Section 31.11.1, NZ7C3 Register Access via JTAG / OnCE](#), using the Nexus register index of 0x9 (see [Table 31-23](#)). Configure the write address to 0xnmmmmmm (write address).
2. Initialize the read/write access control/status register (RWCS) through the access method outlined in [Section 31.11.1, NZ7C3 Register Access via JTAG / OnCE](#), using the Nexus Register Index of 0x7 (see [Table 31-23](#)). Configure the bits as follows:
 - Access Control RWCS[AC] → 0b1 (to indicate start access)
 - Map Select RWCS[MAP] → 0b000 (primary memory map)
 - Access Priority RWCS[PR] → 0b00 (lowest priority)
 - Read/Write RWCS[RW] → 0b1 (write access)
 - Word Size RWCS[SZ] → 0b0xx (32-bit, 16-bit, 8-bit)
 - Access Count RWCS[CNT] → 0x0000 or 0x0001 (single access)

NOTE

Access count RWCS[CNT] of 0x0000 or 0x0001 performs a single access.

3. Initialize the read/write access data register (RWD) through the access method outlined in [Section 31.11.1, NZ7C3 Register Access via JTAG / OnCE](#), using the Nexus register index of 0xA (see [Table 31-23](#)). Configure the write data to 0xnmmmmmm (write data).
4. The NZ7C3 module then arbitrates for the system bus and transfer the data value from the data buffer RWD register to the memory mapped address in the read/write access address register (RWA). When the access has completed without error (ERR=1'b0), NZ7C3 asserts the RDY pin and clears the DV bit in the RWCS register. This indicates that the device is ready for the next access.

NOTE

Only the RDY pin as well as the DV and ERR bits within the RWCS provide read/write access status to the external development tool.

31.14.8.2 Block Write Access (Non-Burst Mode)

1. For a non-burst block write access, follow Steps 1, 2, and 3 outlined in [Section 31.14.8.1, Single Write Access](#) to initialize the registers, but using a value greater than one (0x1) for the RWCS[CNT] field.
2. The NZ7C3 module then arbitrates for the system bus and transfer the first data value from the RWD register to the memory mapped address in the read/write access address register (RWA). When the transfer has completed without error (ERR = 0), the address from the RWA register is incremented to the next word size (specified in the SZ field) and the number from the CNT field is decremented. Nexus then asserts the RDY pin. This indicates it is ready for the next access.
3. Repeat step 3 in [Section 31.14.8.1, Single Write Access](#), until the internal CNT value is zero (0). When this occurs, the DV bit within the RWCS is cleared to indicate the end of the block write access.

31.14.8.3 Block Write Access (Burst Mode)

1. For a burst block write access, follow Steps 1 and 2 outlined in [Section 31.14.8.1, Single Write Access](#), to initialize the registers, using a value of four (doublewords) for the CNT field and a RWCS[SZ] field indicating 64-bit access.
2. Initialize the burst data buffer (read/write access data register) through the access method outlined in [Section 31.11.1, NZ7C3 Register Access via JTAG / OnCE](#), using the Nexus register Index of 0xA (see [Table 31-23](#)).
3. Repeat step 2 until all doubleword values are written to the buffer.

NOTE

The data values must be shifted in 32-bits at a time lsb first (that is, doubleword write = two word writes to the RWD).

4. The Nexus module then arbitrates for the system bus and transfer the burst data values from the data buffer to the system bus beginning from the memory mapped address in the read/write access address register (RWA). For each access within the burst, the address from the RWA register is incremented to the next doubleword size (specified in the SZ field) modulo the length of the burst, and the number from the CNT field is decremented.
5. When the entire burst transfer has completed without error (ERR = 0), NZ7C3 then asserts the RDY pin, and the DV bit within the RWCS is cleared to indicate the end of the block write access.

NOTE

The actual RWA value as well as the CNT field within the RWCS are not changed when executing a block write access (burst or non-burst). The original values can be read by the external development tool at any time.

31.14.8.4 Single Read Access

1. Initialize the read/write access address register (RWA) through the access method outlined in [Section 31.11.1, NZ7C3 Register Access via JTAG / OnCE](#), using the Nexus register index of 0x9 (see [Table 31-23](#)). Configure as follows:
 - Read Address → 0xnxxxxxxxx (read address)
2. Initialize the read/write access control/status register (RWCS) through the access method outlined in [Section 31.11.1, NZ7C3 Register Access via JTAG / OnCE](#), using the Nexus register index of 0x7 (see [Table 31-23](#)). Configure the bits as follows:
 - Access Control RWCS[AC] → 0b1 (to indicate start access)
 - Map Select RWCS[MAP] → 0b000 (primary memory map)
 - Access Priority RWCS[PR] → 0b00 (lowest priority)
 - Read/Write RWCS[RW] → 0b0 (read access)
 - Word Size RWCS[SZ] → 0b0xx (32-bit, 16-bit, 8-bit)
 - Access Count RWCS[CNT] → 0x0000 or 0x0001 (single access)

NOTE

Access Count (CNT) of 0x0000 or 0x0001 performs a single access.

3. The NZ7C3 module then arbitrates for the system bus and the read data is transferred from the system bus to the RWD register. When the transfer is completed without error ($ERR = 0$), Nexus asserts the RDY pin and sets the DV bit in the RWCS register. This indicates that the device is ready for the next access.
4. The data can then be read from the read/write access data register (RWD) through the access method outlined in [Section 31.11.1, NZ7C3 Register Access via JTAG / OnCE](#), using the Nexus register index of 0xA (see [Table 31-23](#)).

NOTE

Only the RDY pin as well as the DV and ERR bits within the RWCS provide Read/Write Access status to the external development tool.

31.14.8.5 Block Read Access (Non-Burst Mode)

1. For a non-burst block read access, follow Steps 1 and 2 outlined in [Section 31.14.8.4, Single Read Access](#), to initialize the registers, but using a value greater than one (0x1) for the CNT field in the RWCS register.
2. The NZ7C3 module then arbitrates for the system bus and the read data is transferred from the system bus to the RWD register. When the transfer has completed without error ($ERR=0b0$), the address from the RWA register is incremented to the next word size (specified in the SZ field) and the number from the CNT field is decremented. Nexus then asserts the RDY pin. This indicates that the device is ready for the next access.
3. The data can then be read from the read/write access data register (RWD) through the access method outlined in [Section 31.11.1, NZ7C3 Register Access via JTAG / OnCE](#), using the Nexus register index of 0xA (see [Table 31-23](#)).
4. Repeat steps 3 and 4 in [Section 31.14.8.4, Single Read Access](#), until the CNT value is zero (0). When this occurs, the DV bit within the RWCS is set to indicate the end of the block read access.

31.14.8.6 Block Read Access (Burst Mode)

1. For a burst block read access, follow Steps 1 and 2 outlined in [Section 31.14.8.4, Single Read Access](#), to initialize the registers, using a value of four (doublewords) for the CNT field and an RWCS[SZ] field indicating 64-bit access.
2. The NZ7C3 module then arbitrates for the system bus and the burst read data is transferred from the system bus to the data buffer (RWD register). For each access within the burst, the address from the RWA register is incremented to the next doubleword (specified in the SZ field) and the number from the CNT field is decremented.
3. When the entire burst transfer has completed without error ($ERR = 0$), Nexus then asserts the RDY pin and the DV bit within the RWCS is set to indicate the end of the block read access.
4. The data can then be read from the burst data buffer (read/write access data register) through the access method outlined in [Section 31.11.1, NZ7C3 Register Access via JTAG / OnCE](#), using the Nexus register index of 0xA (see [Table 31-23](#)).
5. Repeat step 3 until all doubleword values are read from the buffer.

31.14.9 Examples

The following are examples of program trace and data trace messages.

Table 31-30 illustrates an example indirect branch message with an eight MDO and two MSEO configuration.

T0 and S0 are the least significant bits where:

- Tx = TCODE number (fixed)
- Sx = Source processor (fixed)
- Ix = Number of instructions (variable)
- Ax = Unique portion of the address (variable)

Table 31-30. Indirect Branch Message Example (12 MDO and Two MSEO)

| Clock | MDO[11:0] | | | | | | | | | | | | MSEO[1:0] | | State |
|-------|-----------|-----|----|----|----|----|----|----|----|----|----|----|-----------|---|-------------------------------|
| | 11 | 10 | 9 | 8 | 7 | 6 | 5 | 4 | 3 | 2 | 1 | 0 | | | |
| 0 | X | X | X | X | X | X | X | X | X | X | X | X | 1 | 1 | Idle (or end of last message) |
| 1 | I1 | I0 | S3 | S2 | S1 | S0 | T5 | T4 | T3 | T2 | T1 | T0 | 0 | 0 | Start Message |
| 2 | 0 | 0 | 0 | 0 | 0 | 0 | 0 | 0 | I5 | I4 | I3 | I2 | 0 | 1 | End Packet |
| 3 | 0 | A10 | A9 | A8 | A7 | A6 | A5 | A4 | A3 | A2 | A1 | A0 | 1 | 1 | End Packet/End Message |
| 4 | X | X | S3 | S2 | S1 | S0 | T5 | T4 | T3 | T2 | T1 | T0 | 0 | 0 | Start of Next Message |

Table 31-31 illustrates an example of direct branch message with 12 MDO and two MSEO.

T0 and I0 are the least significant bits where:

- Tx = TCODE number (fixed)
- Sx = Source processor (fixed)
- Ix = Number of instructions (variable)

Table 31-31. Direct Branch Message Example (12 MDO and Two MSEO)

| Clock | MDO[11:0] | | | | | | | | | | | | MSEO[1:0] | | State |
|-------|-----------|----|----|----|----|----|----|----|----|----|----|----|-----------|---|-------------------------------|
| | 11 | 10 | 9 | 8 | 7 | 6 | 5 | 4 | 3 | 2 | 1 | 0 | | | |
| 0 | X | X | X | X | X | X | X | X | X | X | X | X | 1 | 1 | Idle (or end of last message) |
| 1 | I1 | I0 | S3 | S2 | S1 | S0 | T5 | T4 | T3 | T2 | T1 | T0 | 0 | 0 | Start Message |
| 2 | 0 | 0 | 0 | 0 | 0 | 0 | 0 | 0 | 0 | 0 | I3 | I2 | 1 | 1 | End Packet and End Message |
| 3 | X | X | X | X | S1 | S0 | T5 | T4 | T3 | T2 | T1 | T0 | 0 | 0 | Start of Next Message |

Table 31-32 an example data write message with 12 MDO and two MSEO configuration.

T0, A0, D0 are the least significant bits (LSB) where:

- Tx = TCODE number (fixed)
- Sx = Source processor (fixed)

- Z_x = Data size (fixed)
- A_x = Unique portion of the address (variable)
- D_x = Write data (variable: 8-, 16- or 32-bit)

Table 31-32. Direct Write Message Example (12 MDO and Two $\overline{\text{MSEO}}$)

| Clock | MDO[11:0] | | | | | | | | | | | | MSEO[1:0] | | State |
|-------|-----------|----|----|----|----|----|----|----|----|----|----|----|-----------|---|-------------------------------|
| | 11 | 10 | 9 | 8 | 7 | 6 | 5 | 4 | 3 | 2 | 1 | 0 | | | |
| 0 | X | X | X | X | X | X | X | X | X | X | X | X | 1 | 1 | Idle (or end of last message) |
| 1 | Z1 | Z0 | S3 | S2 | S1 | S0 | T5 | T4 | T3 | T2 | T1 | T0 | 0 | 0 | Start Message |
| 2 | 0 | 0 | 0 | 0 | 0 | 0 | 0 | A3 | A2 | A1 | A0 | Z2 | 0 | 1 | End Packet |
| 3 | X | X | X | X | D7 | D6 | D5 | D4 | D3 | D2 | D1 | D0 | 1 | 1 | End Packet/End Message |

31.14.10 IEEE 1149.1 (JTAG) RD/WR Sequences

This section contains example JTAG/OnCE sequences used to access resources.

31.14.10.1 JTAG Sequence for Accessing Internal Nexus Registers

Table 31-33. Accessing Internal Nexus3 Registers via JTAG/OnCE

| Step # | TMS Pin | Description |
|--------|---------|---|
| 1 | 1 | IDLE → SELECT-DR_SCAN |
| 2 | 0 | SELECT-DR_SCAN → CAPTURE-DR (Nexus command register value loaded in shifter) |
| 3 | 0 | CAPTURE-DR → SHIFT-DR |
| 4 | 0 | (7) TCK clocks issued to shift in direction (read/write) bit and first 6 bits of Nexus reg. addr. |
| 5 | 1 | SHIFT-DR → EXIT1-DR (7th bit of Nexus reg. shifted in) |
| 6 | 1 | EXIT1-DR → UPDATE-DR (Nexus shifter is transferred to Nexus command register) |
| 7 | 1 | UPDATE-DR → SELECT-DR_SCAN |
| 8 | 0 | SELECT-DR_SCAN → CAPTURE-DR (Register value is transferred to Nexus shifter) |
| 9 | 0 | CAPTURE-DR → SHIFT-DR |
| 10 | 0 | (31) TCK clocks issued to transfer register value to TDO pin while shifting in TDI value |
| 11 | 1 | SHIFT-DR → EXIT1-DR (msb of value is shifted in/out of shifter) |
| 12 | 1 | EXIT1-DR → UPDATE -DR (if access is write, shifter is transferred to register) |
| 13 | 0 | UPDATE-DR → RUN-TEST/IDLE (transfer complete - Nexus controller to reg. select state) |

31.14.10.2 JTAG Sequence for Read Access of Memory-Mapped Resources

Table 31-34. Accessing Memory-Mapped Resources (Reads)

| Step # | TCLK clocks | Description |
|--------|-------------|--|
| 1 | 13 | Nexus Command = write to read/write access address register (RWA) |
| 2 | 37 | Write RWA (initialize starting read address—data input on TDI) |
| 3 | 13 | Nexus Command = write to read/write control/status register (RWCS) |
| 4 | 37 | Write RWCS (initialize read access mode and CNT value—data input on TDI) |
| 5 | — | Wait for falling edge of RDY pin |
| 6 | 13 | Nexus Command = read the read/write access data register (RWD) |
| 7 | 37 | Read RWD (data output on TDO) |
| 8 | — | If CNT > 0, go back to Step #5 |

31.14.10.3 JTAG Sequence for Write Access of Memory-Mapped Resources

Table 31-35. Accessing Memory-Mapped Resources (Writes)

| Step # | TCLK clocks | Description |
|--------|-------------|---|
| 1 | 13 | Nexus Command = write to read/write access control/status register (RWCS) |
| 2 | 37 | Write RWCS (initialize write access mode and CNT value—data input on TDI) |
| 3 | 13 | Nexus Command = write to read/write address register (RWA) |
| 4 | 37 | Write RWA (initialize starting write address—data input on TDI) |
| 5 | 13 | Nexus Command = read the read/write access data register (RWD) |
| 6 | 37 | Write RWD (data output on TDO) |
| 7 | — | Wait for falling edge of RDY pin |
| 8 | — | If CNT > 0, go back to Step #5 |

31.15 Nexus Crossbar eDMA Interface (NXDM) and Nexus Crossbar FlexRay Interface (NXFR)

The third module of the device NDI interface is the e200z7 eDMA Nexus module (NXDM) which is compliant with the Class 3 defined data trace feature of the IEEE-ISTO 5001-2011 standard. The fourth module of the device NDI interface is the FlexRay module (NXFR) which is compliant with the Class 3 defined data trace feature of the IEEE-ISTO 5001-2011 standard. The NXDM can be programmed to trace data accesses for the eDMA module on the system bus. The NXFR can be programmed to trace data accesses for the FlexRay module on the system bus. This eDMA module and FlexRay module as well as the Nexus module are components of the e200z7 platform. All output messages and register accesses are compliant with the protocol defined in the IEEE-ISTO 5001 standard.

NOTE

The auxiliary port and its signals, such as MCKO, MSEO[1:0], MDO[15:0] and others, are referenced. The device NPC module arbitrates the access of the single auxiliary port. The functions of the NXDM and FlexRay modules are described without the interaction of the NPC, as if Nexus has a dedicated auxiliary port, to simplify the description. The auxiliary port function is described in full in [Section 31.2, External Signal Description](#).

31.15.1 Block Diagrams

Figure 31-41 shows a block diagram of the NXDM. The block diagram of the NXFR is the same.

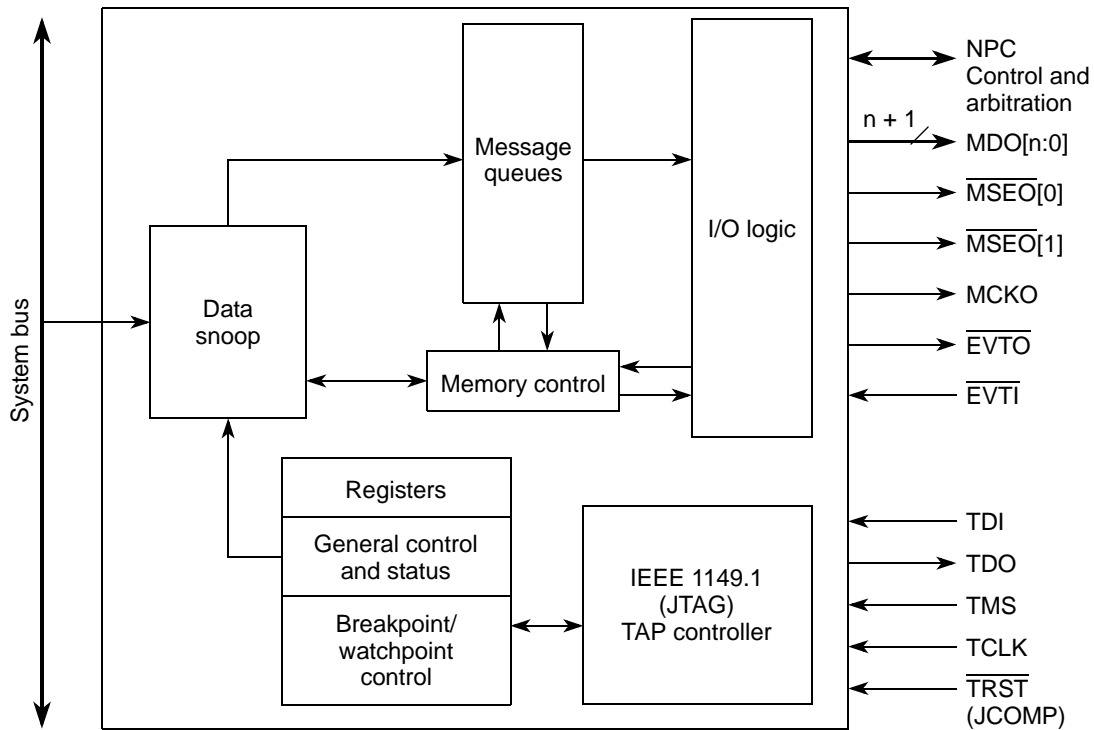

Figure 31-41. NXDM and NXFR Block Diagram

31.15.2 Features

Features include the following:

- Data trace via data write messaging (DWM) and data read messaging (DRM). This provides the capability for the development tool to trace reads and/or writes through the eDMA and FlexRay modules to (selected) internal memory resources.
- Watchpoint messaging via the auxiliary pins.
- Watchpoint trigger enable of data trace messaging (DTM).
- Registers for data trace, watchpoint generation, and watchpoint trigger.
- All features controllable and configurable via the JTAG port.

- Power management.
 - Low power design
 - Dynamic power management of FIFOs and control logic

31.16 External Signal Description

The NXDM (and NXFR) module uses the same pins and pin protocol as defined in [Section 31.2, External Signal Description](#).

31.16.1 Rules for Output Messages

The NXDM (and NXFR) module observe the same rules for output messages as the NPC. Refer to [Section 31.7.2.2.1, Rules of Messages](#).

31.16.2 Auxiliary Port Arbitration

The NXDM (and NXFR) module arbitrate for the shared Nexus port. This arbitration is handled by the NPC (Refer to [Section 31.5, Nexus Port Controller \(NPC\)](#)) based on prioritized requests from the NXDM, NXFR, and the other Nexus clients sharing the port.

31.17 NXDM and NXFR Programmers Model

This section describes the programmers model. Nexus registers are accessed using the JTAG port in compliance with IEEE 1149.1. Refer to [Chapter 32, IEEE 1149.1 Test Access Port Controller \(JTAGC\)](#), and [Section 31.7.2.3, IEEE 1149.1-2001 \(JTAG\) TAP](#), for details on Nexus register access.

31.17.1 NXDM and NXFR Nexus Register Map

Table 31-36. NXDM and NXFR Register Map

| Nexus Register | Nexus Access Opcode | Read/Write | Read Address | Write Address |
|--|---------------------|------------|--------------|---------------|
| Client Select Control (CSC) ¹ | 0x1 | R | 0x02 | – |
| Port Configuration Register (PCR) ¹ | Refer to NPC | R/W | – | – |
| Development Control 1 (DC1 _n) | 0x2 | R/W | 0x04 | 0x05 |
| Development Control 2 (DC2 _n) | 0x3 | R/W | 0x05 | 0x06 |
| Watchpoint Trigger (WT _n) | 0xB | R/W | 0x16 | 0x17 |
| Data Trace Control (DTC _n) | 0xD | R/W | 0x1A | 0x1B |
| Data Trace Start Address 1 (DTSA1 _n) | 0xE | R/W | 0x1C | 0x1D |
| Data Trace Start Address 2 (DTSA2 _n) | 0xF | R/W | 0x1E | 0x1F |
| Data Trace End Address 1 (DTEA1 _n) | 0x12 | R/W | 0x24 | 0x25 |
| Data Trace End Address 2 (DTEA2 _n) | 0x13 | R/W | 0x26 | 0x27 |

Table 31-36. NXDM and NXFR Register Map (continued)

| Nexus Register | Nexus Access Opcode | Read/Write | Read Address | Write Address |
|---|---------------------|------------|--------------|---------------|
| Breakpoint/Watchpoint Control Register 1 (BWC1_n) | 0x16 | R/W | 0x2C | 0x2D |
| Breakpoint/Watchpoint Control Register 2 (BWC2_n) | 0x17 | R/W | 0x2E | 0x2F |
| Breakpoint/Watchpoint Address Register 1 (BWA1_n) | 0x1E | R/W | 0x3C | 0x3D |
| Breakpoint/Watchpoint Address Register 2 (BWA2_n) | 0x1F | R/W | 0x3E | 0x3F |
| Reserved | 0x20–0x3F | – | 0x40–0x7E | 0x41–0x7F |

¹ The CSC and PCR registers are shown in this table as part of the Nexus programmer's model. They are only present at the top level Nexus3 controller (NPC), not in the NXDM or NXFR module. The device's CSC register is readable through Nexus3; the PCR is shown for reference only.

31.17.2 NXDM and NXFR Registers

Detailed register definitions for the NXDM and NXFR implementation are as follows:

31.17.2.1 Development Control Registers (DC1 and DC2)

The development control registers control the basic development features of the NXDM and NXFR modules.

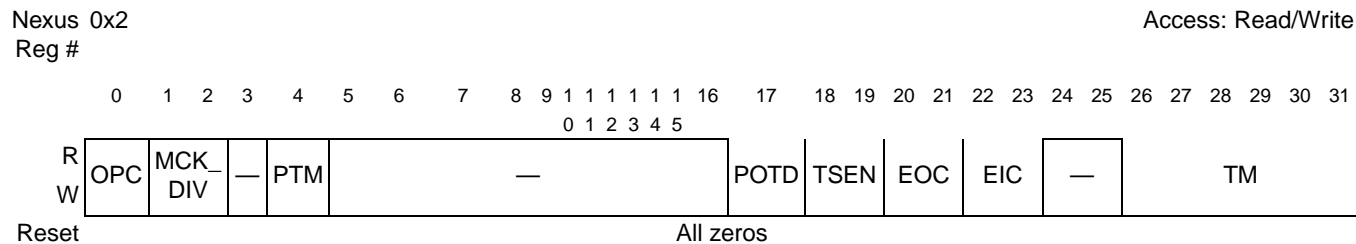

Figure 31-42. Development Control Register 1

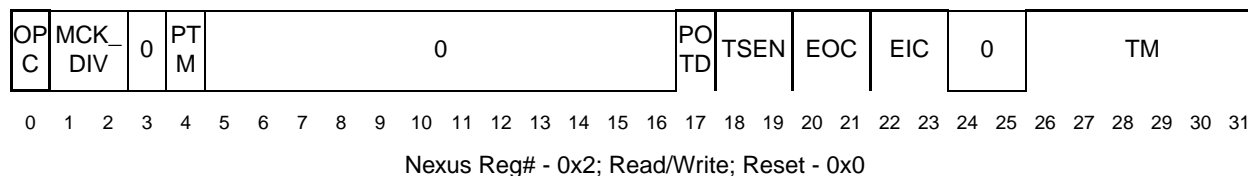

Figure 31-43. Development Control Register 1

Table 31-37. describes its fields.

Table 31-37. Development Control Register 1 Fields

| Field | Description |
|----------------|---|
| 0 OPC | OPC—Output Port Mode Control 0 Reduced Port Mode configuration (min# nex_mdo[n:0] pins defined) 1 Full Port Mode configuration (max# nex_mdo[n:0] pins defined) |
| 1–2 MCK_DIV | MCK_DIV—MCKO Clock Divide Ratio (see note below) 00 nex_mcko is 1x processor clock frequency. 01 nex_mcko is ½x processor clock frequency. 10 nex_mcko is ¼x processor clock frequency. 11 nex_mcko is ⅛ x processor clock frequency. |
| 3 | Reserved for future functionality |
| 4 PTM | PTM—Program Trace Method 0 Program Trace uses traditional branch messages. 1 Program Trace uses branch history messages. |
| 5–16 | Reserved for future functionality |
| 17 POTD | Periodic Ownership Trace Disable 0 Periodic ownership trace message events are enabled. 1 Periodic ownership trace message events are disabled. |
| 18–19 TSEN | Timestamp Enable - (not implemented, write to 00) 00 Timestamp is disabled |
| 20–21 EOC | EOC—EVTO Control 00 nex_evto_b upon occurrence of watchpoints (configured in DC2 and DC3) 01 nex_evto_b upon entry into debug mode 1x Reserved |
| 22–23 EIC | EIC—EVTI Control 00 nex_evti_b is used for synchronization (program trace/data trace) 01 nex_evti_b is used for debug request 1X Reserved |
| 24–25 | Reserved for future functionality |
| 26–31 TM | Trace Mode ¹ 000000 All trace disabled XXXXX1 Ownership trace enabled XXXX1X Data trace enabled XXX1XX Program trace enabled XX1XXX Watchpoint trace enabled X1XXXX Reserved 1XXXXX Data acquisition trace enabled |

¹ This field may be updated by hardware in response to watchpoint triggering. Writes to this field take precedence over hardware updates in the event of a collision.

NOTE

The output port mode control bit (OPC) and MCKO clock divide ratio bits (MCK_DIV) must only be modified during system reset or debug mode to insure correct output port and output clock functionality. It is also recommended that all other bits of the DC1 only be modified in one of these two modes.

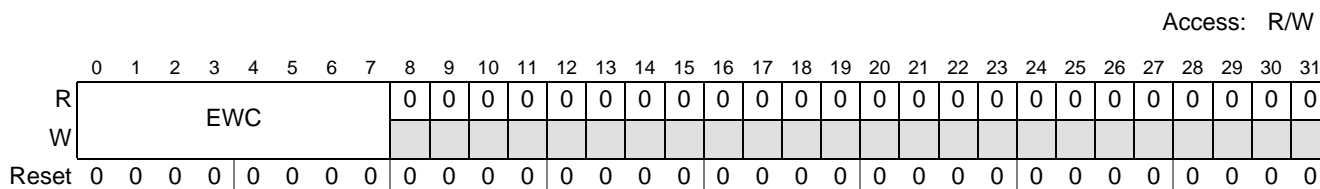

Figure 31-44. Development Control Register 2 (DC2)

Table 31-38. DC2 Field Description

| Field | Description |
|-------------------------|---|
| 0–7 EWC ¹ | \overline{EVTO} Watchpoint Configuration 00000000 = No watchpoints trigger \overline{EVTO} 1XXXXXXXX = Invalid value X1XXXXXXXX = Invalid value XX1XXXXXX = Invalid value XXX1XXXXX = Invalid value XXXX1XXX = Internal watchpoint #1 triggers \overline{EVTO} XXXXX1XX = Internal watchpoint #2 triggers \overline{EVTO} XXXXXX1X = Invalid value XXXXXX1 = Invalid value |
| 8–31 | Reserved, read as 0. |

¹ The EOC bits in DC1 must be programmed to trigger \overline{EVTO} on watchpoint occurrence for the EWC bits to have any effect.

31.17.2.2 Watchpoint Trigger Register (WT)

The watchpoint trigger register allows the watchpoints defined internally to the NXDM and NXFR modules to trigger actions. These watchpoints can control data trace enable and disable. The WT bits can be used to produce an address related window for triggering trace messages.

Access: R/W

| | | | | | | | | | | | | | | | | | | | | | | | | | | | | | | | | |
|-------|---|---|---|---|---|---|-----|---|---|-----|----|----|----|----|----|----|----|----|----|----|----|----|----|----|----|----|----|----|----|----|----|----|
| | 0 | 1 | 2 | 3 | 4 | 5 | 6 | 7 | 8 | 9 | 10 | 11 | 12 | 13 | 14 | 15 | 16 | 17 | 18 | 19 | 20 | 21 | 22 | 23 | 24 | 25 | 26 | 27 | 28 | 29 | 30 | 31 |
| R | 0 | 0 | 0 | 0 | 0 | 0 | DTS | | | DTE | | | 0 | 0 | 0 | 0 | 0 | 0 | 0 | 0 | 0 | 0 | 0 | 0 | 0 | 0 | 0 | 0 | 0 | 0 | 0 | 0 |
| W | | | | | | | | | | | | | | | | | | | | | | | | | | | | | | | | |
| Reset | 0 | 0 | 0 | 0 | 0 | 0 | 0 | | | 0 | | | 0 | 0 | 0 | 0 | 0 | 0 | 0 | 0 | 0 | 0 | 0 | 0 | 0 | 0 | 0 | 0 | 0 | 0 | 0 | 0 |

Figure 31-45. Watchpoint Trigger Register (WT)

Table 31-39. WT Field Description

| Field | Description |
|-------------|--|
| 0–5 | Reserved, read as 0. |
| 6–8 DTS | DTS - Data trace start control 000 Trigger disabled 001–100 Invalid value 101 Use internal watchpoint #1 (BWA1 register) 110 Use internal watchpoint #2 (BWA2 register) 111 Invalid value |
| 9–11 DTE | DTE - Data trace end control 000 Trigger disabled 001–100 Invalid value 101 Use internal watchpoint #1 (BWA1 register) 110 Use internal watchpoint #2 (BWA2 register) 111 Invalid value |
| 12–31 | Reserved, read as 0. |

NOTE

The WT bits ONLY enable data trace if the tm bits within the development control register (DC) have not already been set to enable data trace.

31.17.2.3 Data Trace Control Register (DTC)

The data trace control register controls whether DTM Messages are restricted to reads, writes or both for a user programmable address range. There are two data trace channels controlled by the DTC for the NXDM and NXFR modules.

Access: R/W

| | | | | | | | | | | | | | | | | | | | | | | | | | | | | | | | | |
|-------|------|---|------|---|---|---|---|---|---|---|----|----|----|----|----|----|----|----|----|----|----|----|----|----|-----|-----|----|----|----|----|----|----|
| | 0 | 1 | 2 | 3 | 4 | 5 | 6 | 7 | 8 | 9 | 10 | 11 | 12 | 13 | 14 | 15 | 16 | 17 | 18 | 19 | 20 | 21 | 22 | 23 | 24 | 25 | 26 | 27 | 28 | 29 | 30 | 31 |
| R | RWT1 | | RWT2 | | 0 | 0 | 0 | 0 | 0 | 0 | 0 | 0 | 0 | 0 | 0 | 0 | 0 | 0 | 0 | 0 | 0 | 0 | 0 | 0 | RC1 | RC2 | 0 | 0 | 0 | 0 | 0 | 0 |
| W | | | | | | | | | | | | | | | | | | | | | | | | | | | | | | | | |
| Reset | 0 | 0 | 0 | 0 | 0 | 0 | 0 | 0 | 0 | 0 | 0 | 0 | 0 | 0 | 0 | 0 | 0 | 0 | 0 | 0 | 0 | 0 | 0 | 0 | 0 | 0 | 0 | 0 | 0 | 0 | 0 | 0 |

Figure 31-46. Data Trace Control Register (DTC)

Table 31-40. DTC Field Description

| Bit | Description |
|-------------|---|
| 0–1 RWT1 | Read/write trace 1 00 No trace messages generated X1 Enable data read trace 1X Enable data write trace |
| 2–3 RWT2 | Read/write trace 2 00 No trace messages generated X1 Enable data read trace 1X Enable data write trace |
| 4–23 | Reserved, read as 0. |
| 24 RC1 | Range control 1 0 Condition trace on address within range (endpoints inclusive) 1 Condition trace on address outside of range (endpoints exclusive) |
| 25 RC2 | Range control 2 0 Condition trace on address within range (endpoints inclusive) 1 Condition trace on address outside of range (endpoints exclusive) |
| 26–31 | Reserved, read as 0. |

31.17.2.4 Data Trace Start Address Registers 1 and 2 (DTSA1 and DTSA2)

The data trace start address registers define the start addresses for each trace channel.

Access: R/W

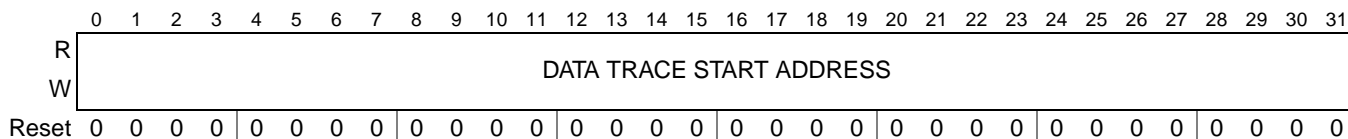

Figure 31-47. Data Trace Start Address Registers (DTSA1, DTSA2)

31.17.2.5 Data Trace End Address Registers 1 and 2 (DTEA1 and DTEA2)

The data trace end address registers define the end addresses for each trace channel.

Access: R/W

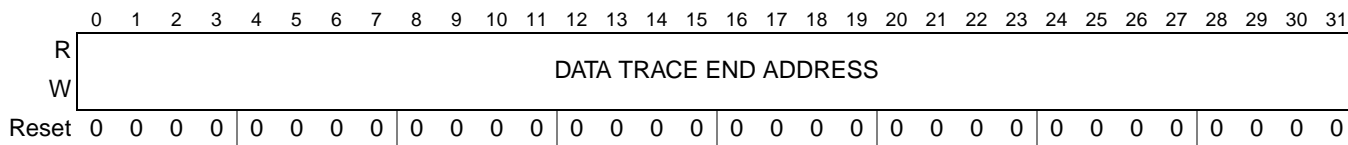

Figure 31-48. Data Trace Start Address Registers (DTEA1, DTEA2)

Table 31-41 illustrates the range that is selected for data trace for various cases of DTSA being less than, greater than, or equal to DTEA.

Table 31-41. Data Trace Address Range Options

| Programmed Values | Range Control Bit Value | Range Selected |
|-------------------|-------------------------|-------------------------|
| DTSA < or = DTEA | 0 | DTSA → ← DTEA |
| DTSA < or = DTEA | 1 | ← DTSA DTEA → |
| DTSA > DTEA | — | Invalid range, no trace |

NOTE

DTSA must be less than (or equal to) DTEA to guarantee correct data write/read traces. When the range control bit is 0 (internal range), accesses to DTSA and DTEA addresses are traced. When the range control bit is 1 (external range), accesses to DTSA and DTEA are not traced.

31.17.2.6 Breakpoint / Watchpoint Control Register 1 (BWC1)

Breakpoint/watchpoint control register 1 controls attributes for generation of NXDM and NXFR watchpoint number 1.

Access: R/W

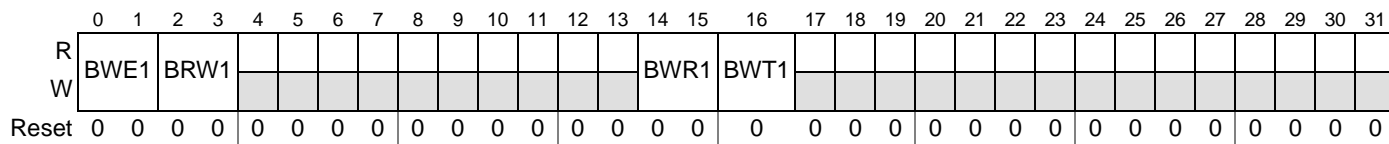

Figure 31-49. Break / Watchpoint Control Register 1 (BWC1)

Table 31-42. BWC1 Field Description

| Field | Description |
|---------------|---|
| 0–1 BWE1 | Breakpoint/watchpoint #1 enable 00 Internal Nexus watchpoint #1 disabled 01–10 Invalid value 11 Internal Nexus watchpoint #1 enabled |
| 2–3 BRW1 | Breakpoint/watchpoint #1 read/write select 00 Watchpoint #1 hit on read accesses 01 Watchpoint #1 hit on write accesses 10 Watchpoint #1 on read or write accesses 11 Invalid value |
| 4–13 | Reserved, read as 0. |
| 17–16 BWR1 | Breakpoint/watchpoint #1 register compare 00 No register compare (same as BWC1[31:30] = 2'b00) 01 Invalid value 10 Compare with BWA1 value 11 Invalid value |
| 15 BWT1 | Breakpoint/watchpoint #1 type 0 Invalid value 1 Watchpoint #1 on data accesses |
| 14–0 | Reserved, read as 0. |

31.17.2.7 Breakpoint / Watchpoint Control Register 2 (BWC2)

Breakpoint/watchpoint control register2 controls attributes for generation of NXDM and NXFR watchpoint number 2.

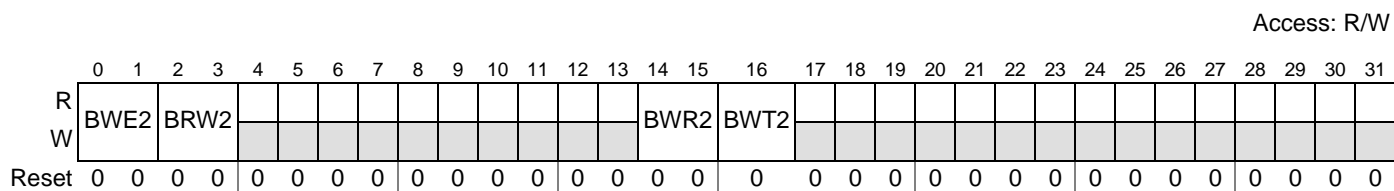

Figure 31-50. Break / Watchpoint Control Register 2 (BWC2)

Table 31-43. BWC2 Field Description

| Field | Description |
|-------------|---|
| 0–1 BWE2 | Breakpoint/watchpoint #2 enable 00 Internal Nexus watchpoint #2 disabled 01–10 Invalid value 11 Internal Nexus watchpoint #2 enabled |
| 2–3 BRW2 | Breakpoint/watchpoint #2 read/write select 00 Watchpoint #2 hit on read accesses 01 Watchpoint #2 hit on write accesses 10 Watchpoint #2 on read or write accesses 11 Invalid value |
| 4–13 | Reserved, read as 0. |

Table 31-43. BWC2 Field Description (continued)

| Field | Description |
|---------------|---|
| 14–15 BWR2 | Breakpoint/watchpoint #2 register compare 00 No register compare (same as BWC1[31:30] = 2'b00) 01 Invalid value 10 Compare with BWA2 value 11 Invalid value |
| 16 BWT2 | Breakpoint/watchpoint #2 Type 0 Invalid value 1 Watchpoint #2 on data accesses |
| 17–31 | Reserved, read as 0. |

31.17.2.8 Breakpoint/Watchpoint Address Registers 1 and 2 (BWA1 and BWA2)

The breakpoint/watchpoint address registers are compared with bus addresses to generate internal watchpoints.

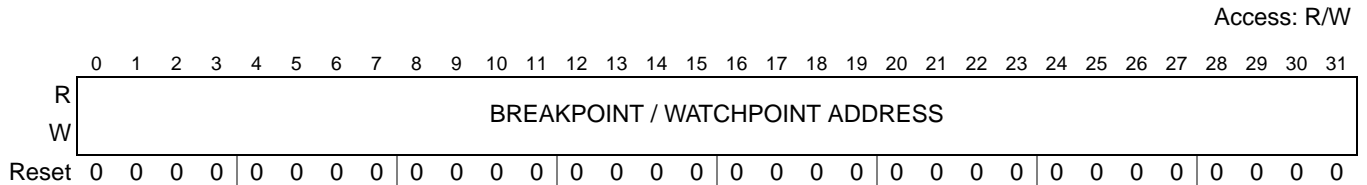
Figure 31-51. Breakpoint / Watchpoint Address Registers (BWA1, BWA2)

31.17.2.9 Unimplemented Registers

Unimplemented registers are those with client select and index value combinations other than those listed in [Table 31-36](#). For unimplemented registers, the NXDM and NXFR modules drives TDO to zero during the “SHIFT-DR” state. It also transmits an error message with the invalid access opcode encoding.

31.17.2.10 Programming Considerations ($\overline{\text{RESET}}$)

If Nexus3 register configuration is to occur during system reset (as opposed to debug mode), all NXDM configuration should be completed between the negation of JCOMP and system reset de-assertion, after the JTAG DID register has been read by the tool.

31.17.2.11 IEEE 1149.1 (JTAG) Test Access Port

The NXDM and NXFR modules uses the IEEE 1149.1 TAP controller for accessing Nexus resources. The JTAG signals themselves are shared by all TAP controllers on the device. Refer to [Chapter 32, IEEE 1149.1 Test Access Port Controller \(JTAPC\)](#), for more information on the JTAG interface.

The NXDM and NXFR modules implements a 4-bit instruction register (IR). The valid instructions and method for register access are outlined in [Section 31.7.2.3, IEEE 1149.1-2001 \(JTAG\) TAP](#).

31.17.2.11.1 NXDM and NXFR JTAG DID Register

This JTAG DID register that is included in the NXDM and NXFR modules provides key development attributes to the development tool concerning the NXDM and NXFR blocks. The register is accessed through the standard JTAG IR/DR paths. Refer to the PMC chapter.

Access: R/W

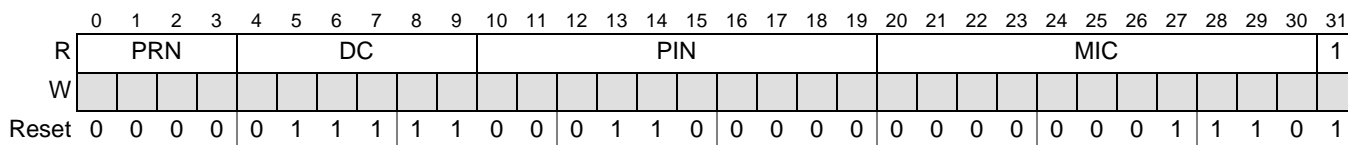

Figure 31-52. NXDM and NXFR JTAG DID Register

Table 31-44. NXDM and NXFR JTAG DID Field Descriptions

| Field | Description |
|-------------------------|---|
| 0–3 PRN ¹ | Embedded part revision number (0x0) |
| 4–9 DC | Freescale design center ID number (0x1F) |
| 10–19 PIN | NXDM and NXFR module part identification number, defines the features set. (0x60) |
| 20–30 MIC | Manufacturer identity code 0x00E Freescale |
| 31 | Fixed per JTAG 1149.1 1 Always set |

¹ The revision number is initially 0 and could change in the future.

31.17.2.11.2 Enabling the NXDM and NXFR TAP Controllers

Assertion of a power-on-reset signal or assertion of the JCOMP pin resets all TAP controllers on the device. Upon exit from the test-logic-reset state, the IR value is loaded with the JTAG DID. When the NXDM or NXFR TAP is accessed, this information helps the development tool obtain information about the Nexus module it is accessing, such as version, sequence, feature set, and so forth.

31.17.2.11.3 NXDM and NXFR Register Access via JTAG

Access to Nexus register resources is enabled by loading a single instruction (NEXUS_ACCESS) into the JTAG Instruction Register (IR). This IR is part of the IEEE 1149.1 TAP controller within the NXDM and NXFR modules. Refer to [Section 32.4.4, JTAGC Instructions](#).

After the JTAG NEXUS_ACCESS instruction has been loaded, the JTAG port allows tool/target communications with all Nexus registers according to the map in [Table 31-36](#).

Reading/writing of a Nexus register then requires two (2) passes through the data-scan (DR) path of the JTAG state machine (refer to [Chapter 32, IEEE 1149.1 Test Access Port Controller \(JTAGC\)](#)).

1. The first pass through the DR selects the Nexus register to be accessed by providing an index (refer to [Table 31-36](#)), and the direction (read/write). This is achieved by loading an 8-bit value into the JTAG data register (DR). This register has the following format:

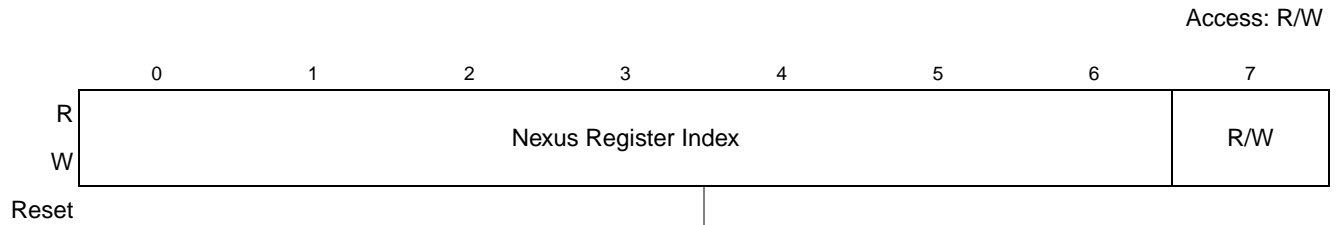

Figure 31-53. JTAG DR for NEXUS Register Access

Table 31-45. DR Read/Write Encoding

| Nexus Register Index | Description |
|----------------------|-------------------|
| Read/Write (R/W) | 0 Read 1 Write |

2. The second pass through the DR then shifts the data in or out of the JTAG port, lsb first.
 - a) During a read access, data is latched from the selected Nexus register when the JTAG state machine passes through the capture-DR state.
 - b) During a write access, data is latched into the selected Nexus register when the JTAG state machine passes through the update-DR state.

31.17.3 Functional Description

31.17.4 Enabling NXDM and NXFR Operation

The NXDM (and NXFR) module is enabled by loading a single instruction (`ACCESS_AUX_TAP_DMA` or `ACCESS_AUX_TAP_NXFR` as shown in [Table 31-4](#)) into the JTAG instruction register (IR), and then loading the corresponding OnCE OCMD register with the `NEXUS_ACCESS` instruction (refer to [Table 31-5](#)). After it is enabled, the module is ready to accept control input via the JTAG pins.

The Nexus module is disabled when the JTAG state machine reaches the test-logic-reset state. This state can be reached by the assertion of the JCOMP pin or by cycling through the state machine using the TMS pin. The Nexus module is also disabled if a power-on reset (POR) event occurs.

If the NXDM (and NXFR) module is disabled, no trace output is provided, and the module disables (drive inactive) auxiliary port output pins (`MDO[15:0]`, `MSEO[1:0]`, `MCKO`). Nexus registers are not be available for reads or writes.

31.17.5 TCODEs Supported by NXDM and NXFR

The NXDM and NXFR pins allow for flexible transfer operations via public messages. A TCODE defines the transfer format, the number and/or size of the packets to be transferred, and the purpose of each packet. The IEEE-ISTO 5001-2003 standard defines a set of public messages. The NXDM and NXFR blocks currently support the public TCODEs seen in [Table 31-46](#).

Table 31-46. Public TCODEs Supported

| Message Name | Packet Size Bits | | Packet Name | Packet Type | Packet Description |
|---|------------------|-----|-------------|-------------|--|
| | Min | Max | | | |
| Data Trace - Date Write Message | 6 | 6 | TCODE | Fixed | TCODE number = 5 |
| | 4 | 4 | SRC | Fixed | Source processor identifier (multiple Nexus configuration) |
| | 3 | 3 | DSZ | Fixed | Data size (refer to Table 31-48) |
| | 1 | 32 | U-ADDR | Variable | Unique portion of the data write value |
| | 1 | 64 | DATA | Variable | Data write value |
| Data Trace - Data Read Message | 6 | 6 | TCODE | Fixed | TCODE number = 6 |
| | 4 | 4 | SRC | Fixed | Source processor identifier (multiple Nexus configuration) |
| | 3 | 3 | DSZ | Fixed | Data size (refer to Table 31-48) |
| | 1 | 32 | U-ADDR | Variable | Unique portion of the data read value |
| | 1 | 64 | DATA | Variable | Data read value |
| Error Message | 6 | 6 | TCODE | Fixed | TCODE number = 8 |
| | 4 | 4 | SRC | Fixed | Source processor identifier (multiple Nexus configuration) |
| | 5 | 5 | ECODE | Fixed | Error code (refer to Table 31-47) |
| Data Trace - Data Write Message w/ Sync | 6 | 6 | TCODE | Fixed | TCODE number = 13 (0xD) |
| | 4 | 4 | SRC | Fixed | Source processor identifier (multiple Nexus configuration) |
| | 3 | 3 | DSZ | Fixed | Data size (refer to Table 31-48) |
| | 1 | 32 | F-ADDR | Variable | Full access address (leading zero (0) truncated) |
| | 1 | 64 | DATA | Variable | Data write value |
| Data Trace - Data Read Message w/ Sync | 6 | 6 | TCODE | Fixed | TCODE number = 14 (0xE) |
| | 4 | 4 | SRC | Fixed | Source processor identifier (multiple Nexus configuration) |
| | 3 | 3 | DSZ | Fixed | Data size (refer to Table 31-48) |
| | 1 | 32 | F-ADDR | Variable | Full access address (leading zero (0) truncated) |
| | 1 | 64 | DATA | Variable | Data read valued |
| Watchpoint Message | 6 | 6 | TCODE | Fixed | TCODE number = 15 (0xF) |
| | 4 | 4 | SRC | Fixed | Source processor identifier (multiple Nexus configuration) |
| | 4 | 4 | WPHIT | Fixed | Number indicating watchpoint sources |

Table 31-47. Error Code (ECODE) Encoding (TCODE = 8)

| Error Code (ECODE) | Description |
|--------------------|--|
| 00000 | Invalid value |
| 00001 | Invalid value |
| 00010 | Data Trace overrun |
| 00011 | Invalid value |
| 00100 | Invalid value |
| 00101 | Invalid access opcode (Nexus Register unimplemented) |
| 00110 | Watchpoint overrun |
| 00111 | Invalid value |
| 01000 | Data Trace and Watchpoint overrun |
| 01001–11111 | Invalid value |

Table 31-48. Data Trace Size (DSZ) Encodings (TCODE = 5, 6, 13, 14)

| DTM Size Encoding | Transfer Size |
|-------------------|--------------------------|
| 000 | Byte |
| 001 | Halfword (two bytes) |
| 010 | Word (four bytes) |
| 011 | Doubleword (eight bytes) |
| 100–111 | Invalid value |

31.17.5.1 Data Trace

This section deals with the data trace mechanism supported by the NXDM and NXFR modules. Data trace is implemented via data write messaging (DWM) and data read messaging (DRM).

31.17.5.2 Data Trace Messaging (DTM)

NXDM and NXFR data trace messaging is accomplished by snooping the NXDM and NXFR data bus, and storing the information for qualifying accesses (based on enabled features and matching target addresses). The NXDM (and NXFR) module traces all data access that meet the selected range and attributes.

NOTE

Data trace is ONLY performed on DMA or FlexRay accesses to the system bus.

31.17.5.3 DTM Message Formats

The NXDM (and NXFR) block supports five types of DTM Messages — data write, data read, data write synchronization, data read synchronization and error messages.

31.17.5.3.1 Data Write and Data Read Messages

The data write and data read messages contain the data write/read value and the address of the write/read access, relative to the previous data trace message. Data write message and data read message information is messaged out in the following format:

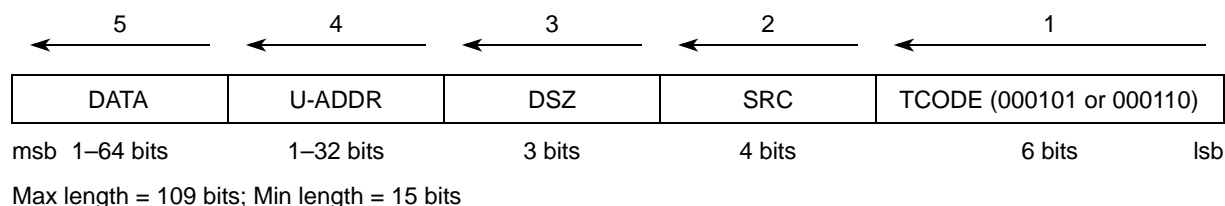

Figure 31-54. Data Write/Read Message Format

31.17.5.3.2 DTM Overflow Error Messages

An error message occurs when a new message cannot be queued due to the message queue being full. The FIFO discards incoming messages until it has completely emptied the queue. After it is emptied, an error message is queued. The error encoding indicates which types of messages attempted to be queued while the FIFO was being emptied.

If only a data trace message attempts to enter the queue while it is being emptied, the error message incorporates the data trace only error encoding (00010). If a watchpoint also attempts to be queued while the FIFO is being emptied, then the error message incorporates error encoding (01000).

Error information is messaged out in the following format:

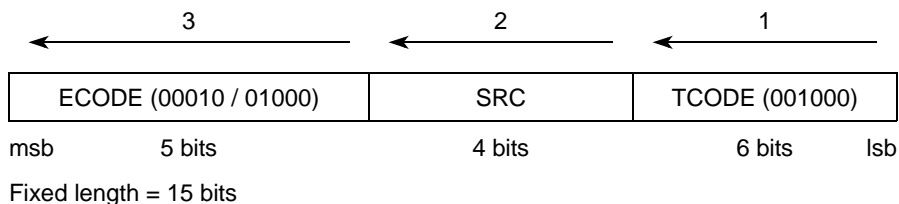

Figure 31-55. Error Message Format

31.17.5.3.3 Data Trace Synchronization Messages

A data trace write/read w/ sync. message is messaged via the auxiliary port (provided data trace is enabled) for the following conditions (refer to [Table 31-49](#)):

- Initial data trace message upon exit from system reset or whenever data trace is enabled is a synchronization message.
- Upon returning from a low power state, the first data trace message is a synchronization message.
- Upon returning from debug mode, the first data trace message is a synchronization message.
- After occurrence of queue overrun (can be caused by any trace message), the first data trace message is a synchronization message.
- After the periodic data trace counter has expired indicating 255 *without-sync* data trace messages have occurred since the last *with-sync* message occurred.
- Upon assertion of the Event In ($\overline{\text{EVTI}}$) pin, the first data trace message is a synchronization message if the eic bits of the dc register have enabled this feature.
- Upon data trace write/read after the previous dtm message was lost due to an attempted access to a secure memory location.
- Upon data trace write/read after the previous dtm message was lost due to a collision entering the fifo between the dtm message and any of the following: error message, or watchpoint message.

Data trace synchronization messages provide the full address (without leading zeros) and insure that development tools fully synchronize with data trace regularly. Synchronization messages provide a reference address for subsequent DTMs, in which only the unique portion of the data trace address is transmitted. The format for data trace write/read w/ sync. messages is as follows:

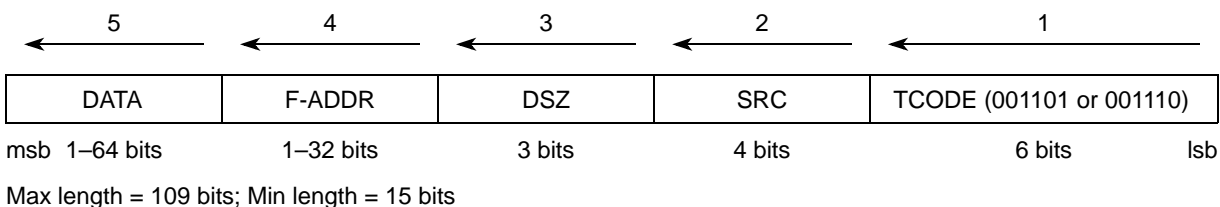

Figure 31-56. Data Write/Read w/ Sync Message Format

Exception conditions that result in data trace synchronization are summarized in [Table 31-49.](#), [Data Trace Exception Summary](#).

Table 31-49. Data Trace Exception Summary

| Exception Condition | Exception Handling |
|-------------------------------------|---|
| System Reset Negation | At the negation of JTAG reset (JCOMP), queue pointers, counters, state machines, and registers within the NXDM and NXFR module are reset. If data trace is enabled, the first data trace message is a data write/read w/ sync. message. |
| Data Trace Enabled | The first data trace message (after data trace has been enabled) is a synchronization message. |
| Exit from Low Power/Debug | Upon exit from a low power mode or debug mode the next data trace message is converted to a data write/read w/ sync. message. |
| Queue Overrun | An error message occurs when a new message cannot be queued due to the message queue being full. The FIFO discards messages until it has completely emptied the queue. After it is emptied, an error message is queued. The error encoding indicates the types of messages that attempted to be queued while the FIFO was being emptied. The next DTM message in the queue is a data write/read w/ sync. message. |
| Periodic Data Trace Synchronization | A forced synchronization occurs periodically after 255 data trace messages have been queued. A data write/read w/ sync. message is queued. The periodic data trace message counter then resets. |
| Event In | If the nexus module is enabled, an $\overline{\text{EVTI}}$ assertion initiates a data trace write/read w/ sync. message upon the next data write/read (if data trace is enabled and the eic bits of the dc register have enabled this feature). |
| Attempted Access to Secure Memory | Any attempted read or write to secure memory locations temporarily disable data trace & cause the corresponding DTM to be lost. A subsequent read/write queues a data trace read/write with sync. message. |
| Collision Priority | All messages have the following priority: Error → WPM → DTM. A DTM message which attempts to enter the queue at the same time as an error message, or watchpoint message is lost. A subsequent read/write queues a data trace read/write with sync. message. |

31.17.5.4 DTM Operation

31.17.5.4.1 Enabling Data Trace Messaging

Data trace messaging can be enabled in one of two ways.

- Setting the DC1[TM] field to enable data trace
- Using the WT[DTS] field to enable data trace on watchpoint hits

31.17.5.4.2 DTM Queuing

NXDM and NXFR implements a programmable depth queue for queuing all messages. Messages that enter the queue are transmitted via the auxiliary pins in the order in which they are queued.

NOTE

If multiple trace messages must be queued at the same time, watchpoint messages have the highest priority (WPM → DTM).

31.17.5.4.3 Relative Addressing

The relative address feature is compliant with IEEE-ISTO 5001-2011 and is designed to reduce the number of bits transmitted for addresses of data trace messages. Relative addressing is the same as described for the NZ7C3 in [Section 31.14.2, Relative Addressing](#).

31.17.5.4.4 Data Trace Windowing

Data write/read messages are enabled via the RWT1(2) field in the data trace control register (DTC) for each DTM channel. Data trace windowing is achieved via the address range defined by the DTEA and DTSA registers and by the RC1(2) field in the DTC. All eDMA or FlexRay initiated read/write accesses that fall inside or outside these address ranges, as programmed, are candidates to be traced.

31.17.5.4.5 System Bus Cycle Special Cases

Table 31-50. System Bus Cycle Special Cases

| Special Case | Action |
|--|--------------------------------|
| System bus cycle aborted (DABORT asserted) | Cycle ignored |
| System bus cycle with data error | Data Trace Message discarded |
| System bus cycle completed without error | Cycle captured and transmitted |
| System bus cycle is an instruction fetch | Cycle ignored |

31.17.5.5 Data Trace Timing Diagrams (Eight MDO configuration)

Data trace timing for the NXDM and NXFR is the same as for the NZ7C3. Refer to [Section 31.14.6.4, Data Trace Timing Diagrams \(Eight MDO Configuration\)](#).

31.17.6 Watchpoint Support

The NXDM and NXFR module provides watchpoint messaging via the auxiliary pins, as defined by IEEE-ISTO 5001-2003.

Watchpoint messages can be generated using the NXDM and NXFR defined internal watchpoints.

31.17.6.1 Watchpoint Messaging

Enabling watchpoint messaging is accomplished by setting the watchpoint messaging enable bit, DC1[WEN]. Using the BWC1 and BWC2 registers, two independently controlled internal watchpoints can be initialized. When a DMA or FlexRay access address matches on BWA1 or BWA2, a watchpoint message is transmitted.

The Nexus module provides watchpoint messaging using the TCODE. When either of the two possible watchpoint sources asserts, a message is sent to the queue to be messaged out. This message indicates the watchpoint number.

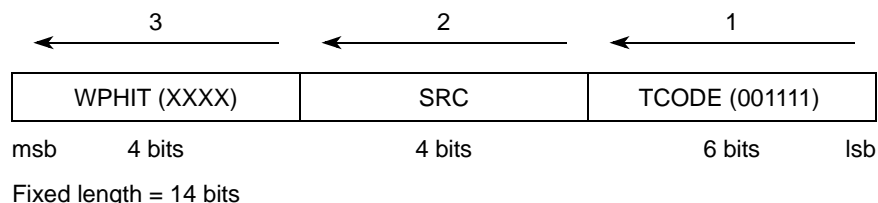

Figure 31-57. Watchpoint Message Format

Table 31-51. Watchpoint Source Description

| Watchpoint Source (4 bits) | Watchpoint Description |
|----------------------------|-------------------------------------|
| XXX1 | Invalid value |
| XX1X | Invalid value |
| X1XX | Internal Watchpoint #1 (BWA1 match) |
| 1XXX | Internal Watchpoint #2 (BWA2 match) |

31.17.6.2 Watchpoint Error Message

An error message occurs when a new message cannot be queued due to the message queue being full. The FIFO discards messages until it has completely emptied the queue. After it is emptied, an error message is queued. The error encoding indicates which types of messages attempted to be queued while the FIFO was being emptied.

If only a watchpoint message attempts to enter the queue while it is being emptied, the error message incorporates the watchpoint only error encoding (00110). If a data trace message also attempts to enter the queue while it is being emptied, the error message incorporates error encoding (01000).

Error information is messaged out in the following format (refer to Figure 31-58).

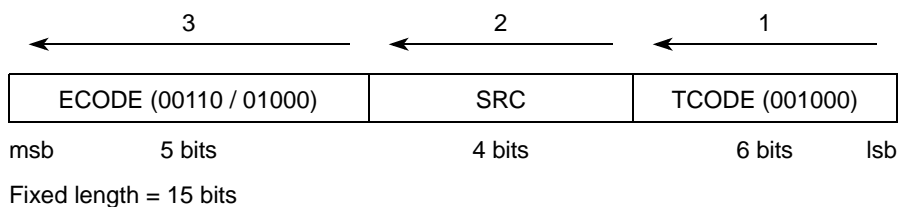

Figure 31-58. Error Message Format



Chapter 32

IEEE 1149.1 Test Access Port Controller (JTAGC)

32.1 Introduction

The JTAG port of the device consists of four inputs and one output. These pins include JTAG compliance select (JCOMP), test data input (TDI), test data output (TDO), test mode select (TMS), and test clock input (TCK). TDI, TDO, TMS, and TCK are compliant with the IEEE 1149.1-2001 standard and are shared with the NDI through the test access port (TAP) interface.

32.1.1 Block Diagram

Figure 32-1 is a block diagram of the JTAG Controller (JTAGC).

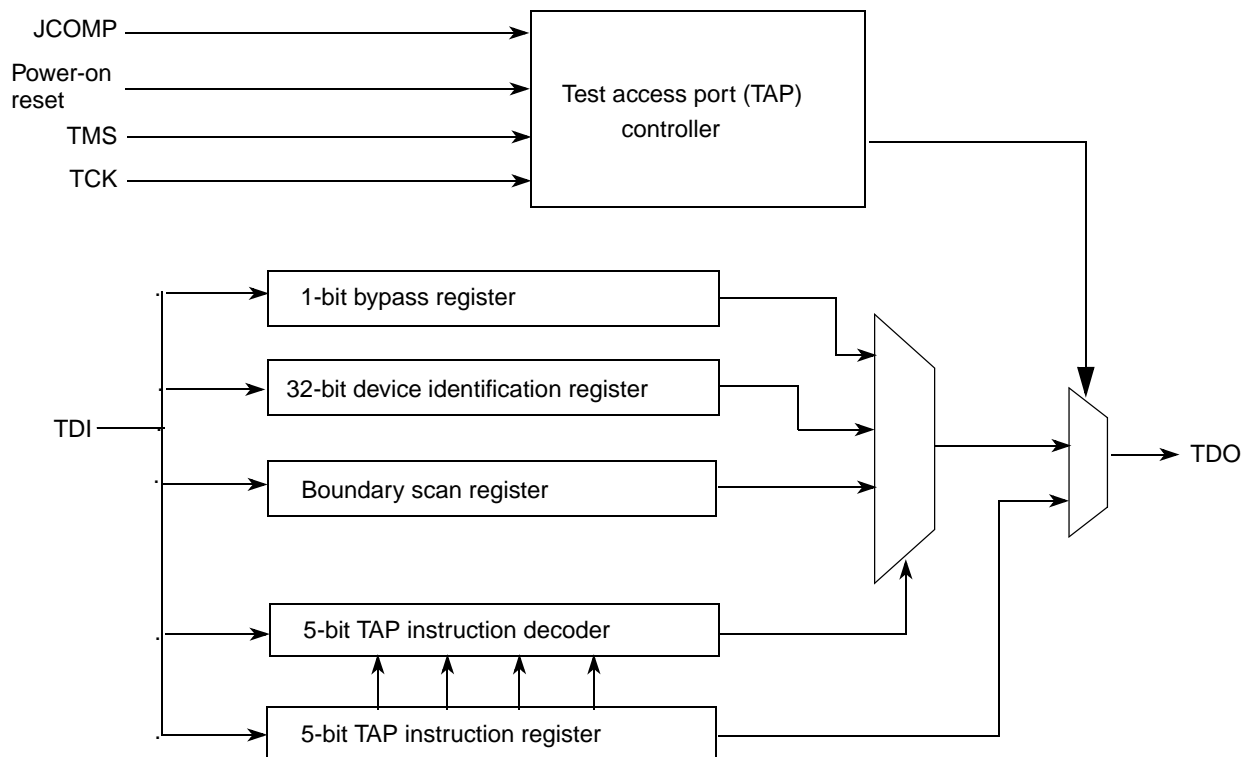

Figure 32-1. JTAG Controller Block Diagram

32.1.2 Overview

The JTAGC provides the means to test chip functionality and connectivity while remaining transparent to system logic when not in test mode. Testing is performed via a boundary scan technique, as defined in the IEEE 1149.1-2001 standard. In addition, instructions can be executed that allow the Test Access Port (TAP) to be shared with other modules on the MCU. All data input to and output from the JTAGC is communicated in serial format.

32.1.3 Features

The JTAGC is compliant with the IEEE 1149.1-2001 standard, and supports the following features:

- IEEE 1149.1-2001 Test Access Port (TAP) interface.
- 4 pins (TDI, TMS, TCK, and TDO), Refer to [Section 32.2, External Signal Description](#).
- A JCOMP input that provides the ability to share the TAP.
- A 5-bit instruction register that supports several IEEE 1149.1-2001 defined instructions, as well as several public and private MCU specific instructions.
- Four test data registers: a bypass register, a boundary scan register, and a device identification register. The size of the boundary scan register is 480 bits.
- A TAP controller state machine that controls the operation of the data registers, instruction register and associated circuitry.

32.1.4 Modes of Operation

The JTAGC uses JCOMP and a power-on reset indication as its primary reset signals. Several IEEE 1149.1-2001 defined test modes are supported, as well as a bypass mode.

32.1.4.1 Reset

The JTAGC is placed in reset when the TAP controller state machine is in the TEST-LOGIC-RESET state. The TEST-LOGIC-RESET state is entered upon the assertion of the power-on reset signal, negation of JCOMP, or through TAP controller state machine transitions controlled by TMS. Asserting power-on reset or negating JCOMP results in asynchronous entry into the reset state. While in reset, the following actions occur:

- The TAP controller is forced into the test-logic-reset state, thereby disabling the test logic and allowing normal operation of the on-chip system logic to continue unhindered.
- The instruction register is loaded with the IDCODE instruction.

In addition, execution of certain instructions can result in assertion of the internal system reset. These instructions include EXTEST, CLAMP, and HIGHZ.

32.1.4.2 IEEE 1149.1-2001 Defined Test Modes

The JTAGC supports several IEEE 1149.1-2001 defined test modes. The test mode is selected by loading the appropriate instruction into the instruction register while the JTAGC is enabled. Supported test instructions include EXTEST, HIGHZ, CLAMP, SAMPLE and SAMPLE/PRELOAD. Each instruction

defines the set of data registers that can operate and interact with the on-chip system logic while the instruction is current. Only one test data register path is enabled to shift data between TDI and TDO for each instruction.

The boundary scan register is enabled for serial access between TDI and TDO when the EXTEST, SAMPLE or SAMPLE/PRELOAD instructions are active. The single-bit bypass register shift stage is enabled for serial access between TDI and TDO when the HIGHZ, CLAMP or reserved instructions are active. The functionality of each test mode is explained in more detail in [Section 32.4.4, JTAGC Instructions](#).

32.1.4.3 Bypass Mode

When no test operation is required, the BYPASS instruction can be loaded to place the JTAGC into bypass mode. While in bypass mode, the single-bit bypass shift register is used to provide a minimum-length serial path to shift data between TDI and TDO.

32.1.4.4 TAP Sharing Mode

The selectable auxiliary TAP controllers that share the TAP with the JTAGC are:

- Nexus port controller (NPC)
- e200 OnCE
- eTPU Nexus
- eDMA A Nexus
- eDMA B Nexus
- FlexRay

The instructions required to grant ownership of the TAP to the auxiliary TAP controllers are:

- ACCESS_AUX_TAP_NPC
- ACCESS_AUX_TAP_ONCE
- ACCESS_AUX_TAP_eTPU
- ACCESS_AUX_TAP_DMA_A
- ACCESS_AUX_TAP_DMA_B
- ACCESS_AUX_TAP_NXFR

Instruction opcodes for each instruction are shown in [Table 32-3](#).

When the access instruction for an auxiliary TAP is loaded, control of the JTAG pins is transferred to the selected TAP controller. Any data input via TDI and TMS is passed to the selected TAP controller, and any TDO output from the selected TAP controller is sent back to the JTAGC to be output on the pins. The JTAGC regains control of the JTAG port during the UPDATE-DR state if the PAUSE-DR state was entered. Auxiliary TAP controllers are held in RUN-TEST/IDLE while they are inactive.

For more information on the TAP controllers refer to [Chapter 31, Nexus Development Interface \(NDI\)](#).

32.2 External Signal Description

The JTAGC consists of five signals that connect to off-chip development tools and allow access to test support functions. The JTAGC signals are outlined in the following table:

Table 32-1. JTAG Signal Properties

| Name | I/O | Function | Reset State | Pull ¹ |
|-------|-----|------------------|---------------------|-------------------|
| TCK | I | Test clock | — | Down |
| TDI | I | Test data in | — | Up |
| TDO | O | Test data out | High Z ² | Down ² |
| TMS | I | Test mode select | — | Up |
| JCOMP | I | JTAG compliancy | — | Down |

¹ The pull is not implemented in this module. Pullup/down devices are implemented in the pads.

² TDO output buffer enable is negated when JTAGC is not in the Shift-IR or Shift-DR states. A weak pulldown can be implemented on TDO.

32.3 Memory Map/Register Definition

This section provides a detailed description of the JTAGC registers accessible through the TAP interface, including data registers and the instruction register. Individual bit-level descriptions and reset states of each register are included. These registers are not memory-mapped and can only be accessed through the TAP.

32.3.1 Instruction Register

The JTAGC uses a 5-bit instruction register as shown in [Figure 32-2](#). The instruction register allows instructions to be loaded into the module to select the test to be performed or the test data register to be accessed or both. Instructions are shifted in through TDI while the TAP controller is in the Shift-IR state, and latched on the falling edge of TCK in the Update-IR state. The latched instruction value can only be changed in the update-IR and test-logic-reset TAP controller states. Synchronous entry into the test-logic-reset state results in the IDCODE instruction being loaded on the falling edge of TCK. Asynchronous entry into the test-logic-reset state results in asynchronous loading of the IDCODE instruction. During the capture-IR TAP controller state, the instruction shift register is loaded with the value 0b10101, making this value the register's read value when the TAP controller is sequenced into the Shift-IR state.

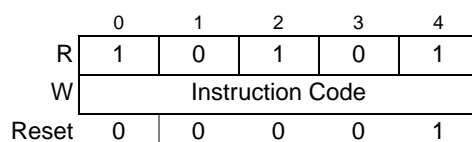

Figure 32-2. 5-Bit Instruction Register

32.3.2 Bypass Register

The bypass register is a single-bit shift register path selected for serial data transfer between TDI and TDO when the BYPASS, CLAMP, HIGHZ or reserve instructions are active. After entry into the capture-DR state, the single-bit shift register is set to a logic 0. Therefore, the first bit shifted out after selecting the bypass register is always a logic 0.

32.3.3 Device Identification Register

The device identification register, shown in Figure 32-3, allows the part revision number, design center, part identification number, and manufacturer identity code to be determined through the TAP. The device identification register is selected for serial data transfer between TDI and TDO when the IDCODE instruction is active. Entry into the capture-DR state while the device identification register is selected loads the IDCODE into the shift register to be shifted out on TDO in the Shift-DR state. No action occurs in the update-DR state.

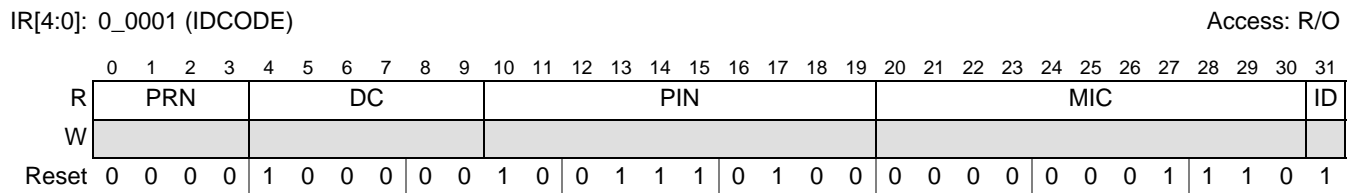

Figure 32-3. Device Identification Register

Table 32-2. Device Identification Register Field Descriptions

| Field | Description |
|--------------|--|
| 0–3 PRN | Part revision number. Contains the revision number of the device. This field changes with each revision of the device or module. |
| 4–9 DC | Design center. Indicates the Freescale design center. For the MPC5574 this value is 0x20. |
| 10–19 PIN | Part identification number. Contains the part number of the device. For the MPC5574, this value is 0x274. |
| 20–30 MIC | Manufacturer identity code. Contains the reduced Joint Electron Device Engineering Council (JEDEC) ID for Freescale, 0xE. |
| 31 ID | IDCODE register ID. Identifies this register as the device identification register and not the bypass register. Always set to 1. |

32.3.4 SENSOR_CTRL Register

The SENSOR_CTRL register is a 64-bit shift register path from TDI to TDO selected when the ENABLE_SENSOR_CTRL instruction is active. The default reset value of the SENSOR_CTRL register is 64'b0. The SENSOR_CTRL register transfers its value to a parallel hold register on the rising edge of TCK when the TAP controller state machine is in the Update-DR state. Once the ENABLE_SENSOR_CTRL instruction is executed, the register value will remain valid until a JTAG reset occurs.

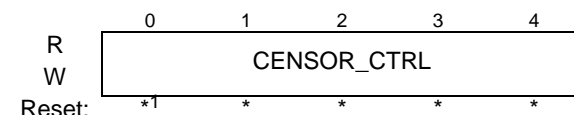

¹ The reset value of CENSOR_CTRL is 64'b0.

Figure 1. CENSOR_CTRL Register

CENSOR_CTRL - Censorship Control

The CENSOR_CTRL bits are used to control chip-top censorship functions.

32.3.5 Boundary Scan Register

The boundary scan register is connected between TDI and TDO when the EXTEST, SAMPLE or SAMPLE/PRELOAD instructions are active. It is used to capture input pin data, force fixed values on output pins, and select a logic value and direction for bidirectional pins. Each bit of the boundary scan register represents a separate boundary scan register cell, as described in the IEEE 1149.1-2001 standard and discussed in [Section 32.4.5, Boundary Scan](#).

32.4 Functional Description

32.4.1 JTAGC Reset Configuration

While in reset, the TAP controller is forced into the test-logic-reset state, thus disabling the test logic and allowing normal operation of the on-chip system logic. In addition, the instruction register is loaded with the IDCODE instruction.

32.4.2 IEEE 1149.1-2001 (JTAG) Test Access Port

The JTAGC uses the IEEE 1149.1-2001 TAP for accessing registers. This port can be shared with other TAP controllers on the MCU. Ownership of the port is determined by the value of the JCOMP signal and the currently loaded instruction. For more detail on TAP sharing via JTAGC instructions refer to [Section 32.4.4.2, ACCESS_AUX_TAP_x Instructions](#).

Data is shifted between TDI and TDO through the selected register starting with the least significant bit, as illustrated in [Figure 32-4](#). This applies for the instruction register, test data registers, and the bypass register.

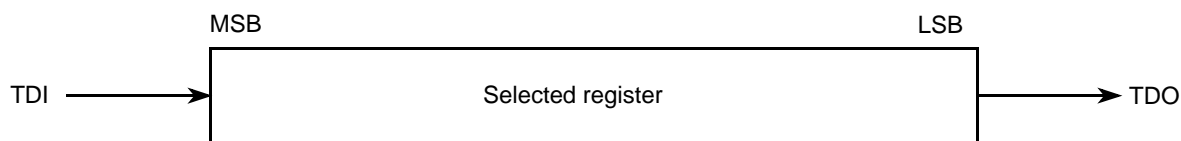
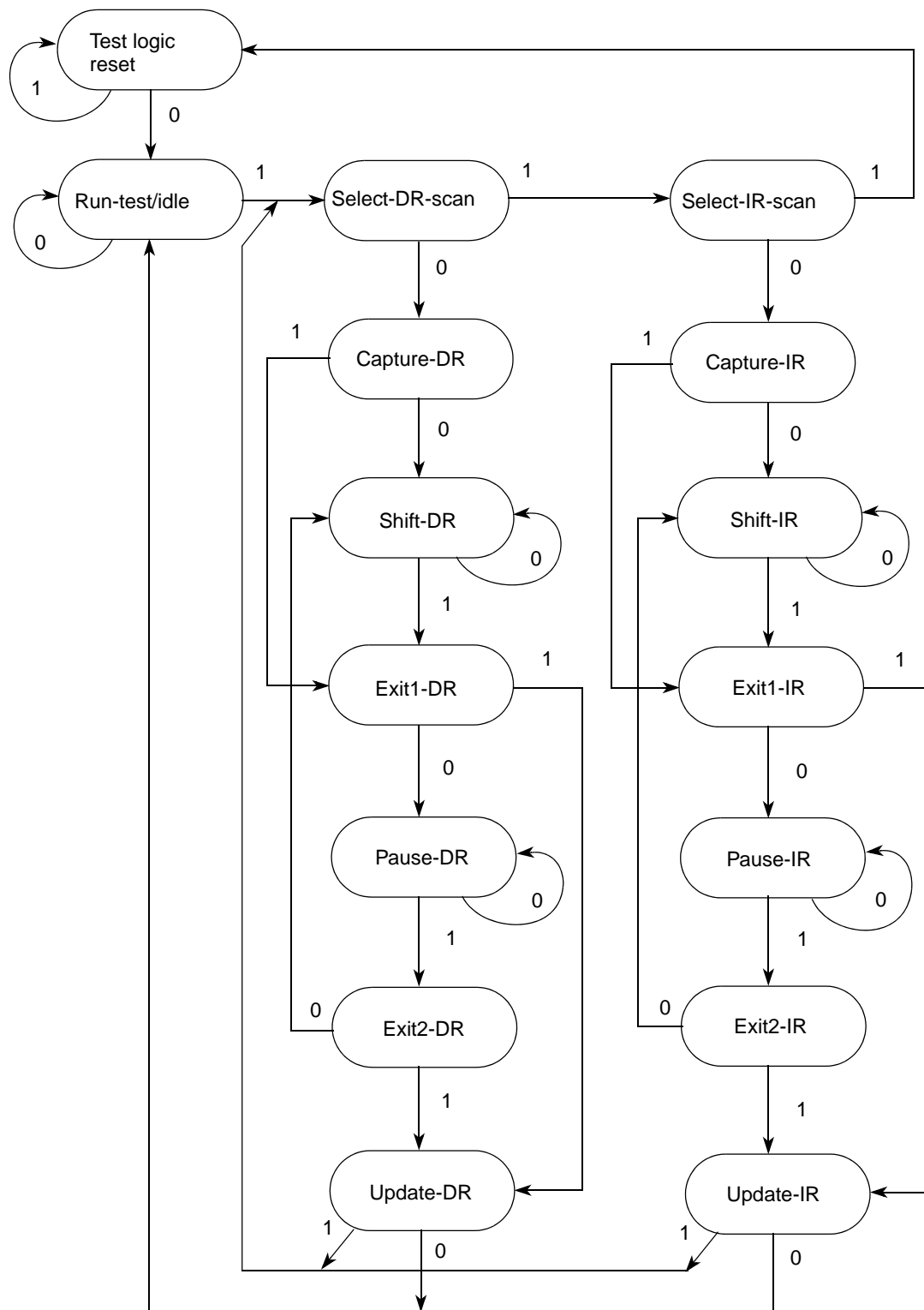

Figure 32-4. Shifting Data Through a Register

32.4.3 TAP Controller State Machine

The TAP controller is a synchronous state machine that interprets the sequence of logical values on the TMS pin. [Figure 32-5](#) shows the machine's states. The value shown next to each state is the value of the TMS signal sampled on the rising edge of the TCK signal.

As [Figure 32-5](#) shows, holding TMS at logic 1 while clocking TCK through a sufficient number of rising edges also causes the state machine to enter the test-logic-reset state.



NOTE: The value shown adjacent to each state transition in this figure represents the value of TMS at the time of a rising edge of TCK.

Figure 32-5. IEEE 1149.1-2001 TAP Controller Finite State Machine

32.4.3.1 Enabling the TAP Controller

The JTAGC TAP controller is enabled by setting JCOMP to a logic 1 value.

32.4.3.2 Selecting an IEEE 1149.1-2001 Register

Access to the JTAGC data registers is done by loading the instruction register with any of the JTAGC instructions while the JTAGC is enabled. Instructions are shifted in via the select-IR-scan path and loaded in the update-IR state. At this point, all data register access is performed via the select-DR-scan path.

The select-DR-scan path is used to read or write the register data by shifting in the data (LSB first) during the shift-DR state. When reading a register, the register value is loaded into the IEEE 1149.1-2001 shifter during the capture-DR state. When writing a register, the value is loaded from the IEEE 1149.1-2001 shifter to the register during the update-DR state. When reading a register, there is no requirement to shift out the entire register contents. Shifting can be terminated after fetching the required number of bits.

32.4.4 JTAGC Instructions

This section gives an overview of each instruction, refer to the IEEE 1149.1-2001 standard for more details.

The JTAGC implements the IEEE 1149.1-2001 defined instructions listed in [Table 32-3](#).

Table 32-3. JTAG Instructions

| Instruction | Code[4:0] | Instruction Summary |
|----------------------|-----------|---|
| IDCODE | 00001 | Selects device identification register for shift |
| SAMPLE/PRELOAD | 00010 | Selects boundary scan register for shifting, sampling, and preloading without disturbing functional operation |
| SAMPLE | 00011 | Selects boundary scan register for shifting and sampling without disturbing functional operation |
| EXTEST | 00100 | Selects boundary scan register while applying preloaded values to output pins and asserting functional reset |
| ENABLE_CENSOR_CTRL | 00111 | Selects CENSOR_CTRL register |
| HIGHZ | 01001 | Selects bypass register while three-stating all output pins and asserting functional reset |
| CLAMP | 01100 | Selects bypass register while applying preloaded values to output pins and asserting functional reset |
| ACCESS_AUX_TAP_NPC | 10000 | Grants the Nexus port controller (NPC) ownership of the TAP |
| ACCESS_AUX_TAP_ONCE | 10001 | Grants the Nexus e200z7 core interface (NZ7C3) ownership of the TAP |
| ACCESS_AUX_TAP_eTPU | 10010 | Grants the Nexus dual-eTPU development interface (NDEDI) ownership of the TAP |
| ACCESS_AUX_TAP_DMA_A | 10011 | Grants the Nexus crossbar DMA A interface (NXDM) ownership of the TAP |
| ACCESS_AUX_TAP_NXFR | 10100 | Enables access to the FlexRay Nexus TAP controller |
| ACCESS_AUX_TAP_DMA_B | 10111 | Grants the Nexus crossbar DMA B interface (NXDM) ownership of the TAP |

Table 32-3. JTAG Instructions (continued)

| Instruction | Code[4:0] | Instruction Summary |
|-------------------------------------|-------------------------|---|
| BYPASS | 11111 | Selects bypass register for data operations |
| Factory Debug Reserved ¹ | 00101 00110 01010 | Intended for factory debug only |
| Reserved ² | All Other Codes | Decoded to select bypass register |

¹ Intended for factory debug, and not customer use

² Freescale reserves the right to change the decoding of reserved instruction codes

32.4.4.1 BYPASS Instruction

BYPASS selects the bypass register, creating a single-bit shift register path between TDI and TDO. BYPASS enhances test efficiency by reducing the overall shift path when no test operation of the MCU is required. This allows more rapid movement of test data to and from other components on a board that are required to perform test functions. While the BYPASS instruction is active the system logic operates normally.

32.4.4.2 ACCESS_AUX_TAP_x Instructions

The ACCESS_AUX_TAP_x instructions allow the Nexus modules on the MCU to take control of the TAP. When this instruction is loaded, control of the TAP pins is transferred to the selected auxiliary TAP controller. Any data input via TDI and TMS is passed to the selected TAP controller, and any TDO output from the selected TAP controller is sent back to the JTAGC to be output on the pins. The JTAGC regains control of the JTAG port during the UPDATE-DR state if the PAUSE-DR state was entered. Auxiliary TAP controllers are held in RUN-TEST/IDLE while they are inactive.

32.4.4.3 CLAMP Instruction

CLAMP allows the state of signals driven from MCU pins to be determined from the boundary scan register while the bypass register is selected as the serial path between TDI and TDO. CLAMP enhances test efficiency by reducing the overall shift path to a single bit (the bypass register) while conducting an EXTEST type of instruction through the boundary scan register. CLAMP also asserts the internal system reset for the MCU to force a predictable internal state.

32.4.4.4 EXTEST — External Test Instruction

EXTEST selects the boundary scan register as the shift path between TDI and TDO. It allows testing of off-chip circuitry and board-level interconnections by driving preloaded data contained in the boundary scan register onto the system output pins. Typically, the preloaded data is loaded into the boundary scan register using the SAMPLE/PRELOAD instruction before the selection of EXTEST. EXTEST asserts the internal system reset for the MCU to force a predictable internal state while performing external boundary scan operations.

32.4.4.5 ENABLE_CENSOR_CTRL Instruction

The ENABLE_CENSOR_CTRL instruction selects the CENSOR_CTRL register for connection as the shift path between TDI and TDO.

32.4.4.6 HIGHZ Instruction

HIGHZ selects the bypass register as the shift path between TDI and TDO. While HIGHZ is active, all output drivers are placed in an inactive drive state (for example, high impedance). HIGHZ also asserts the internal system reset for the MCU to force a predictable internal state.

32.4.4.7 IDCODE Instruction

IDCODE selects the 32-bit device identification register as the shift path between TDI and TDO. This instruction allows interrogation of the MCU to determine its version number and other part identification data. IDCODE is the instruction placed into the instruction register when the JTAGC is reset.

32.4.4.8 SAMPLE Instruction

The SAMPLE instruction obtains a sample of the system data and control signals present at the MCU input pins and just before the boundary scan register cells at the output pins. This sampling occurs on the rising edge of TCK in the capture-DR state when the SAMPLE instruction is active. The sampled data is viewed by shifting it through the boundary scan register to the TDO output during the Shift-DR state. There is no defined action in the update-DR state. Both the data capture and the shift operation are transparent to system operation.

32.4.4.9 SAMPLE/PRELOAD Instruction

The SAMPLE/PRELOAD instruction has two functions:

- The SAMPLE part of the instruction samples the system data and control signals on the MCU input pins and just before the boundary scan register cells at the output pins. This sampling occurs on the rising-edge of TCK in the capture-DR state when the SAMPLE/PRELOAD instruction is active. The sampled data is viewed by shifting it through the boundary scan register to the TDO output during the shift-DR state. Both the data capture and the shift operation are transparent to system operation.
- The PRELOAD part of the instruction initializes the boundary scan register cells before selecting the EXTEST or CLAMP instructions to perform boundary scan tests. This is achieved by shifting in initialization data to the boundary scan register during the shift-DR state. The initialization data is transferred to the parallel outputs of the boundary scan register cells on the falling edge of TCK in the update-DR state. The data is applied to the external output pins by the EXTEST or CLAMP instruction. System operation is not affected.

32.4.5 Boundary Scan

The boundary scan technique allows signals at component boundaries to be controlled and observed through the shift-register stage associated with each pad. Each stage is part of a larger boundary scan register cell, and cells for each pad are interconnected serially to form a shift-register chain around the border of the design. The boundary scan register consists of this shift-register chain, and is connected between TDI and TDO when the EXTEST, SAMPLE, or SAMPLE/PRELOAD instructions are loaded. The shift-register chain contains a serial input and serial output, as well as clock and control signals.

32.5 Initialization/Application Information

The test logic is a static logic design, and TCK can be stopped in either a high or low state without loss of data. However, the system clock is not synchronized to TCK internally. Any mixed operation using both the test logic and the system functional logic requires external synchronization.

To initialize the JTAGC module and enable access to registers, the following sequence is required:

1. Set the JCOMP signal to logic 1, thereby enabling the JTAGC TAP controller.
2. Load the appropriate instruction for the test or action to be performed.

Chapter 33

Device Performance Optimization

33.1 Introduction

The PXR40 contains several features that can influence the overall level of performance provided by the device.

Some of these features may be initialized upon negation of reset either by a software program called the Boot Assist Module (BAM), by a hardware state machine or by appropriate default register settings. Although the device exits the reset state into a functional state it does not necessarily have the default optimum performance settings for any given application.

This chapter provides guidance for users to fully optimize their application to achieve the highest possible performance from the PXR40. It provides a description of the areas that should be focused on when optimizing an application for performance by describing the features and recommending settings to be applied. It focuses on hardware configurations although certain aspects of the application software such as compiler settings and optimizations will be discussed.

33.2 Features

The PXR40 has the following hardware features that can be configured to impact the overall performance of the device:

- Branch Prediction
 - Branch Target Buffer
 - Branch Prediction Control
- Frequency Modulated PLL
- Flash Bus Interface Unit
 - Flash access wait state and address pipelining control
 - Flash instruction prefetching
 - Flash data prefetching
- Crossbar switch
- System Cache
 - Instruction Cache
 - Data Cache
- Memory Management Unit

Further application level features can impact the application performance:

- Hardware Single Precision Floating point

- Signal Processing Extension (SPE-APU)
- Variable Length Encoding (VLE)
- Compiler optimizations

Further factors that impact the overall application performance are the use of the intelligent peripherals:

- Use of DMA rather than CPU to transfer data efficiently
- Use of DMA service requests rather than CPU interrupts to avoid software polling:
- Off-loading tasks from the CPU to the eTPU2 or eDMA
- Careful allocation of cache usage for code & data ranges, particularly when using with external memories.

Different items in this list will have different performance impacts in a real system. Features like the system cache, the FMPLL and the flash access times tend to provide the most significant performance impacts in terms of hardware settings.

The subsequent sections in this chapter will describe how to configure and use these features appropriately.

33.3 Configuring Hardware Features

33.3.1 Branch Target Buffer (BTB)

33.3.1.1 Description

To resolve branch instructions and improve the accuracy of branch predictions the e200z7 core implements a dynamic branch prediction mechanism using a branch target buffer (BTB), a fully associative address cache of branch target addresses. Its purpose is to accelerate the execution of software loops with some potential change of flow within the loop body. In addition, the BTB on the e200z7 has a subroutine call stack that speeds up indirect branches.

33.3.1.2 Recommended Configuration

By default, this BTB is disabled following negation of reset. It is controlled by the Branch Unit Control and Status Register (BUCSR). The BTB's contents should be flushed and invalidated by writing `BUCSR[BBFI]=1`, and it may be enabled by subsequently writing `BUCSR[BPEN]=1`.

Additional control is available in `BUCSR[BPRED]` and `BUCSR[BALLOC]` to control whether forward or backward branches (or both) are candidates for entry into the BTB, and thus for branch prediction. By default the `BUCSR[BPRED]` and `BUCSR[BALLOC]` fields are set to `0b00`, which enables forward and backward branch prediction. It is recommended to not disable branch prediction although for extremely fine tuning of a given application the optimum setting of `BUCSR[BPRED]` and `BUCSR[BALLOC]` should be assessed.

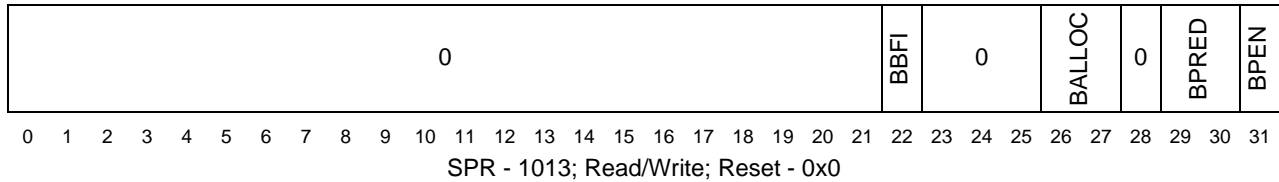
Figure 33-1. Branch Unit Control & Status Register (BUCSR)
Table 33-1. BUCSR Register Field Descriptions

| Field | Description |
|-----------------|---|
| 0–21 | Reserved |
| 22 BBFI | Branch target buffer flash invalidate. When set, BBFI flash clears the valid bit of all BTB entries; clearing occurs regardless of the value of the enable bit (BPEN). Note: BBFI is always read as 0. |
| 23–25 | Reserved |
| 26–27 BALLOC | Branch Target Buffer Allocation Control 00- Branch Target Buffer allocation for all branches is enabled. 01- Branch Target Buffer allocation is disabled for backward branches. 10- Branch Target Buffer allocation is disabled for forward branches. 11- Branch Target Buffer allocation is disabled for both branch directions. This field controls BTB allocation for branch acceleration when BPEN=1. Note that BTB hits are not affected by the settings of this field. Note that for branches with "AA'=1", the MSB of the displacement field is still used to indicate forward/backward, even though the branch is absolute. |
| 28 | Reserved |
| 29–30 BPRED | Branch Prediction Control (Static) 00- Branch predicted taken on BTB miss for all branches. 01- Branch predicted taken on BTB miss only for forward branches. 10- Branch predicted taken on BTB miss only for backward branches. 11- Branch predicted not taken on BTB miss for both branch directions. This field controls operation of static prediction mechanism on a BTB miss. Unless disabled, fetching of the predicted target location will be performed for branch acceleration. BPRED operates independently of BPEN, and with a BPEN setting of 0, will be used to perform static prediction of all unresolved branches. Note that BTB hits are not affected by the settings of this field. Note that for certain applications, setting BPRED to a non-default value may result in improved performance. |
| 31 BPEN | Branch target buffer (BTB) enable. 0 BTB prediction disabled. No hits are generated from the BTB and no new entries are allocated. Entries are not automatically invalidated when BPEN is cleared; BBFI controls entry invalidation. 1 BTB prediction enabled (enables BTB to predict branches). |

Further details of the BUCSR register can be found in the e200z7 Reference Manual.

33.3.2 Frequency Modulated PLL

33.3.2.1 Description

The Frequency Modulated Phase Locked Loop (FMPLL) allows the user to generate high speed system clocks from a crystal oscillator or external clock generator. Further, the FMPLL supports programmable frequency modulation of the system clock. This module is typically configured early in the initialization code to ensure satisfactory performance levels are achieved.

33.3.2.2 Recommended configuration

The default operating frequency of the PXR40 device is 2 to 3 times the crystal reference frequency depending on the state of the PLL configuration pins as reset negates. Typically, the system frequency is increased shortly after reset negates to provide acceptable performance. [Chapter 6, Frequency Modulated Phase-Locked Loop \(FMPLL\)](#), provides details on how the frequency modulated phase locked loop (FMPLL) should be initialized in an application. The maximum frequency of operation for this device is specified in the *PXR40 Microcontroller Data Sheet*.

System performance cannot be linearly extrapolated with system frequency, as is often the expectation. It is due to the insertion of additional Flash wait states as system frequency increases that system performance does not scale linearly. Take care to ensure that the correct internal and/or external Flash configuration is chosen for the selected system frequency. The specific flash access times to be applied are detailed in [Section 12.2.2.8, Flash Bus Interface Configuration Register \(FLASH_BIUCR\)](#).

33.3.3 Flash Bus Interface Unit

33.3.3.1 Description

The Flash Bus Interface Unit (FBIU) interfaces the system bus to the Flash memory array controller. The FBIU contains prefetch buffers and a prefetch controller which, if enabled, speculatively prefetches sequential lines of data from the Flash array into the buffer. Prefetch buffer hits allow zero-wait state responses.

The Flash Bus Interface Configuration Registers (BIUCRx) control access to the internal Flash array. Its settings define the number of cycles required to access the array, access times, and how the prefetch buffering scheme operates.

Following negation of reset and execution of the BAM, the instruction and data prefetching is disabled, and the number of cycles required to access the internal Flash array is set to its maximum value of fifteen additional wait states.

33.3.3.2 Recommended configuration

As the operating frequency of the device is set by configuring the FMPLL (see [Section 33.3.2, Frequency Modulated PLL](#)), the number of cycles required to access the internal array should be configured accordingly. Note that the Flash BIUCRx registers cannot be altered by code executing from the Flash

array. Code for configuring the Flash should be executed from a separate memory array i.e copied to and executed from system RAM.

[Section 12.2.2.8, Flash Bus Interface Configuration Register \(FLASH_BIUCR\)](#), contains the required Flash wait state settings for a given operating frequency. This also provides recommendations for the prefetch buffer settings. Note that the BIUCRx settings may vary between revisions of the PXR40.

33.3.4 Crossbar Switch

33.3.4.1 Description

The multi-port crossbar switch (XBAR) supports simultaneous connections between master ports and slave ports. The XBAR allows for concurrent transactions to occur from any master port to any slave port. If a slave port is simultaneously requested by more than one master port, arbitration logic selects the higher priority master and grants it ownership of the slave port. All other masters requesting that slave port are stalled until the higher priority master completes its transactions. By default, requesting masters are granted access based on a fixed priority. A round-robin priority mode also is available.

The main goal of the XBAR is to increase overall system performance by allowing multiple masters to communicate concurrently with multiple slaves. In order to maximize data throughput it is essential to keep arbitration delays to a minimum. The configuration of the crossbar can have implications for the performance of a system and particular care should be taken when assigning master priorities in a fixed priority application. Further, by correctly parking slaves on relevant masters the initial access times to the slaves can be minimized by negating any initial arbitration penalties.

33.3.4.2 Recommended Configuration

The specific settings for a given situation are application dependent and thus should be assessed by the user. However, some general guidelines are available.

Optimal XBAR settings are application dependent, but in e200z4/7 (Harvard configuration) based devices assigning the CPU data bus to have highest priority and parking the slave port associated with system RAM on this master generally provides the best overall performance.

To reconfigure the XBAR as described on the PXR40, write the following registers:

1. XBAR_SGPCR2 = 0x0000_0001. This parks the slave 2 (internal SRAM) on master port 1 (CPU data bus)
2. Write XBAR_MPR0 = 0x5432_0001. This sets slave port 0 (Flash) to give the master port 1 (CPU data bus) highest priority.

On the e200z4/z7 based devices it may also be beneficial to assign the eDMA to have highest priority for the Flash slave port depending upon the application.

More details of the XBAR register configuration can be found in [Chapter 14, AMBA Crossbar Switch \(XBAR\)](#).

33.3.5 Cache

33.3.5.1 Description

The PXR40 provides an 16kB Instruction and 16kB Data, 4-way set-associative, harvard cache design with a 32-byte line size. The cache is disabled by default when reset is negated.

The cache improves system performance by providing low-latency instructions and data to the e200z7 instruction and data pipelines, which decouples processor performance from system memory performance. There are several stages to enabling the cache. Not only does the cache itself have to be invalidated then enabled, but memory regions upon which it can operate must be configured in the MMU to permit cache access.

33.3.5.2 Recommended configuration

The exact usage of cache is application dependent but some general guidelines for using cache to improve performance in a typical application are listed below:

- Enable instruction cache for all internal & external memories that code is being executed from.
- Enable data cache for internal data memories that are not shared, unless the application can guarantee that coherency is maintained between multiple masters.
- Consider locking the stack within the data cache.
- Copyback mode in the cache generally uses fewer system resources. However, write through mode is better for coherency and to protect for future multi-core devices that require write-through mode be set for inter-core coherency.
- Consider locking critical performance routines in cache.
- Avoid caching memory mapped peripherals for coherency reasons.

The process of enabling the instruction cache involves first invalidating the cache (by setting L1CSR1[ICINV]) then when invalidation is completed (L1CSR1[ICINV, ICABT]=0) enabling the cache (by setting L1CSR1[ICE]). A similar process for the data cache using L1CSR0 is required.

The L1CSR1 and L1CSR0 special purpose registers are detailed below. For further details of cache configuration registers refer to the e200z7 core reference manual.

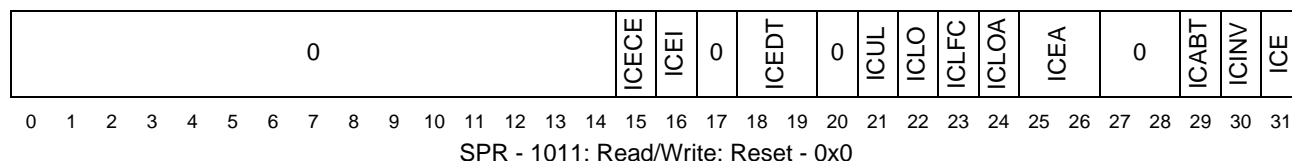

Figure 33-2. L1 Cache Control & status Register 1 (L1CSR1)

Table 33-2. L1CSR1 Register Field Descriptions

| Field | Description |
|-------------|---|
| 0–14 | Reserved |
| 15 ICECE | Instruction Cache Error Checking Enable |

Table 33-2. L1CSR1 Register Field Descriptions (continued)

| Field | Description |
|----------------|---|
| 16 ICEI | Instruction Cache Error Injection Enable |
| 17 | Reserved |
| 18–19 ICEDT | Instruction Cache Error Detection Type |
| 20 | Reserved |
| 21 ICUL | Instruction Cache Unable to Lock |
| 22 ICLO | Instruction Cache Lock Overflow |
| 23 ICLFC | Instruction Cache Lock Bits Flash Clear |
| 24 ICLOA | Instruction Cache Lock Overflow Allocate |
| 25–26 ICEA | Instruction Cache Error Action |
| 27–28 | Reserved |
| 29 ICABT | <p>Instruction Cache Operation Aborted</p> <p>Indicates a Cache Invalidate or a Cache Lock Bits Flash Clear operation was aborted prior to completion. This bit is set by hardware on an aborted condition, and will remain set until cleared by software writing 0 to this bit location.</p> |
| 30 ICINV | <p>Instruction Cache Invalidate</p> <p>0 - No cache invalidate</p> <p>1 - Cache invalidation operation</p> <p>When written to a '1', a cache invalidation operation is initiated by hardware. Once complete, this bit is reset to '0'. Writing a '1' while an invalidation operation is in progress will result in an undefined operation. Writing a '0' to this bit while an invalidation operation is in progress will be ignored. Cache invalidation operations require approximately 36 cycles to complete. Invalidation occurs regardless of the enable (ICE) value.</p> <p>During cache invalidations, the parity check bits are written with a value dependent on the ICEDT selection. ICEDT should be written with the desired value for subsequent cache operation when ICINV is set to '1' for proper operation of the cache.</p> |
| 31 ICE | <p>Instruction Cache Enable</p> <p>0 - Cache is disabled</p> <p>1 - Cache is enabled</p> <p>When disabled, cache lookups are not performed for instruction accesses. Other L1CSR0 cache control operations are still available.</p> |

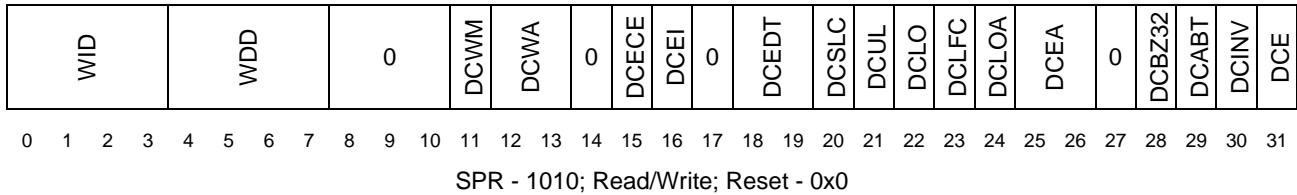
Figure 33-3. L1 Cache Control & status Register 0(L1CSR0)
Table 33-3. L1CSR0 Register Field Descriptions

| Field | Description |
|----------------|---|
| 0–3 WID | Way Instruction Disable |
| 4–7 WDD | Way Data Disables |
| 8–10 | Reserved |
| 11 DCWM | Data Cache Write Mode |
| 12–13 DCWA | Data Cache Write Allocation Policy |
| 14 | Reserved |
| 15 DCECE | Data Cache Error Checking Enable |
| 16 DCEI | Data Cache Error Injection |
| 17 | Reserved |
| 18–19 DCEDT | Data Cache Error Detection Type |
| 20 DCSLC | Data Cache Snoop Lock Clear |
| 21 DCUL | Data Cache Unable to Lock |
| 22 DCLO | Data Cache Lock Overflow |
| 23 DCLFC | Data Cache Lock Bits Flash Clear |
| 24 DCLOA | Data Cache Lock Overflow Allocate |
| 25–26 DCEA | Data Cache Error Action |
| 27 | Reserved |
| 28 DCBZ32 | Data Cache dcba , dcbz operation length |

Table 33-3. L1CSR0 Register Field Descriptions (continued)

| Field | Description |
|-------------|--|
| 29 DCABT | <p>Data Cache Operation Aborted</p> <p>Indicates a Cache Invalidate or a Cache Lock Bits Flash Clear operation was aborted prior to completion. This bit is set by hardware on an aborted condition, and will remain set until cleared by software writing 0 to this bit location.</p> |
| 30 DCINV | <p>Data Cache Invalidate</p> <p>0 - No cache invalidate 1 - Cache invalidation operation</p> <p>When written to a '1', a cache invalidation operation is initiated by hardware. Once complete, this bit is reset to '0'. Writing a '1' while an invalidation operation is in progress will result in an undefined operation. Writing a '0' to this bit while an invalidation operation is in progress will be ignored. Cache invalidation operations require approximately 134 cycles to complete. Invalidation occurs regardless of the enable (DCE) value.</p> <p>During cache invalidations, the parity check bits are written with a value dependent on the DCEDT selection. DCEDT should be written with the desired value for subsequent cache operation when DCINV is set to '1' for proper operation of the cache.</p> |
| 31 DCE | <p>Data Cache Enable</p> <p>0 - Cache is disabled 1 - Cache is enabled</p> <p>When disabled, cache lookups are not performed for normal load or store accesses, or for snoop requests. Other L1CSR0 cache control operations are still available. Also, operation of the store buffer is not affected by DCE.</p> |

Note that configuration of the cache has to be performed in conjunction with configuration of the Memory Management unit. Refer to section [Section 33.3.6, Memory Management Unit \(MMU\)](#).

33.3.6 Memory Management Unit (MMU)

33.3.6.1 Description

The Memory Management Unit is a 32-bit *PowerPC Book E* compliant implementation which provides functionality that includes address translation and application of access attributes to memory ranges defined in Translation Lookaside Buffer entries. Although the MMU does not directly impact performance, it is within the MMU that memory regions are configured to permit the use of system cache to improve performance and Variable Length Encoding (VLE) to enhance code density. Thus it is essential that the MMU is correctly configured to ensure optimal application performance is achieved.

33.3.6.1.1 Recommended configuration

The core uses MMU Assist Registers (MASx) which are special purpose registers to facilitate reading, writing & searching the Translation Lookaside Buffer (TLB) entries. These MAS registers are software

managed by **tlbre**, **tlbwe**, **tlbsx**, **tlbsync**, and **tlbivax** instructions. Refer to the core reference manual for full details of the MMU and its configurations.

There are several MMU Assist Register registers (MAS0-3) that require configuring. Details of these are provided in the e200z7 reference manual. Specifically, the MAS 2 register contains the fields to control whether a specified memory region described by the valid TLB Entry is cache inhibited or whether VLE encoding is valid.

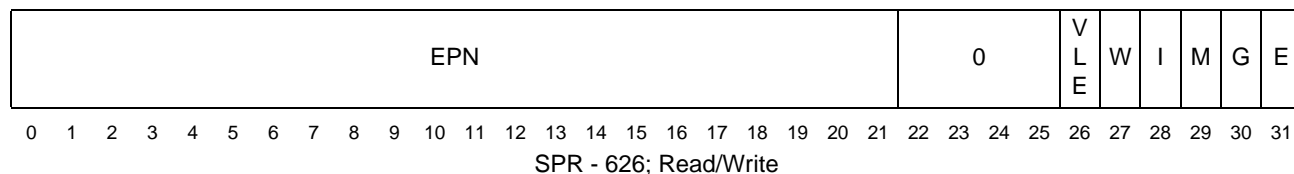

Figure 33-4. MMU Assist Register 2 (MAS2)

Table 33-4. MAS2 Register Field Descriptions

| Field | Description |
|-------------|---|
| 0–21 EPN | Effective page number [0:21] |
| 22–25 | Reserved |
| 26 VLE | PowerPC VLE 0 - This page is a standard BookE page 1 - This page is a PowerPC VLE page |
| 27 W | Write-through Required |
| 28 I | Cache Inhibited 0 - This page is considered cacheable 1 - This page is considered cache-inhibited |
| 29 M | Memory Coherence Required |
| 30 G | Memory Coherence Required |
| 31 E | Endianness |

Refer to the e200z7 core reference manual for further details of MMU configuration registers.

33.4 Application Software

33.4.1 Compiler Optimizations

The most significant opportunity for influencing the performance of a given application is by compiler and linker optimizations. Optimizing is a trade off between code size and performance. Typically higher

performance of the application comes at the expense of larger code size. Compilers use a host of features, such as loop unrolling, function inlining and application profile feedback to make the desired trade-offs between enhanced performance and minimized code size.

The data in Figure 33-5 shows the effects of compiler optimization on a simple application. In this case, the Dhrystone benchmark was run under three conditions:

- Optimized for small code size
- Optimized for high performance
- A Trade-off between code size and performance

Although this is an extreme example, it highlights how significant the role of the compiler and linker is in determining the overall performance of an application.

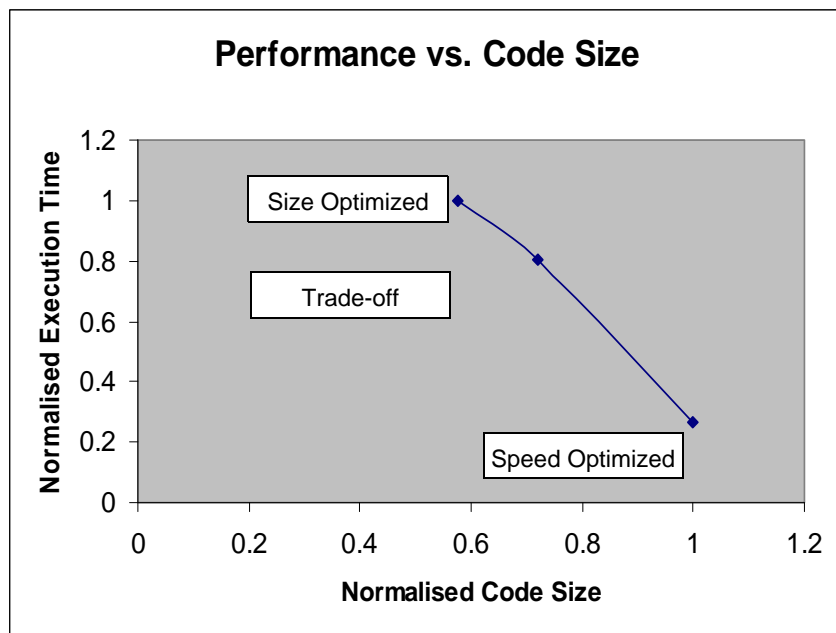

Figure 33-5. Influence of Compiler Settings on Application Performance and Code Size

NOTE

Data measured using Dhrystone version 2.1 run on a Power Architecture based Powertrain device using a standard commercial compiler.

The compiler optimizations do not necessarily have to be applied to the entire application. Analysis of an application can identify time critical functions that may subsequently be targeted for performance optimization, without incurring the impact of optimizing the entire application.

There are several other aspects of the compiler and linker that should be considered. In particular, the use of Small Data Areas (SDAs, sometimes referred to as Special Data Areas) can make a significant performance improvement. Refer to compiler documentation for usage guidelines on Small Data Areas.

Table 33-5. MSR Register Field Descriptions (continued)

| Field | Description |
|-----------|------------------------------|
| 23 FE | Floating-Point Available |
| 24–25 | Reserved |
| 26 IS | Instruction Address Space |
| 27 DS | Data Address Space |
| 28 | Reserved |
| 29 PMM | PMM Performance Monitor Mark |
| 30 RI | Recoverable Interrupt |
| 31 | Reserved |

33.4.3 Hardware Single Precision Floating Point

The SPE-APU also supports 32-bit IEEE®-754 single-precision floating-point formats, and supports vector and scalar single-precision floating-point operations. Most compiler vendors include libraries that can emulate floating point functionality. However, by specifying the correct compiler options, the single precision floating point instructions may be used.

To enable use of hardware floating point the MSR[SPE] field must be set. Refer to [Section 33.4.2, Signal Processing Extension](#), for register details.

33.4.4 Variable Length Encoding

In addition to the base Power Architecture Book E instruction set support, the e200z7 core also implement the VLE (variable-length encoding) APU, providing improved code density. The VLE-APU can be viewed as a supplement to the existing Power Architecture instruction set that can be conditionally applied to a portion of, or an entire application for which improved code density is desired.

Using it is straightforward:

1. Select the appropriate compiler target and option to generate VLE code.
2. Configure the Memory Management Unit (MMU) to specify VLE attributes for the relevant MMU pages. Refer to the register description in [Section 33.3.6, Memory Management Unit \(MMU\)](#).

VLE-enabled cores run both Book E and VLE instruction encodings on a page by page basis, with pages defined by the MMU. The reduction in code size is typically between 25% & 30%.

33.5 Peripherals and General Application Guidelines

Optimizing the device configuration and compiler setup is only one part of optimizing an entire application. Correct use of the peripherals can also dramatically improve overall system performance. In particular, use of the interrupt controller, the enhanced Direct Memory Access (eDMA), and intelligent peripherals such as the Enhanced Timer Processing unit (eTPU2), can off-load significant work from the CPU.

For example, the eDMAs may be used to shift data to avoid unnecessary CPU loading. Most peripheral modules can generate eDMA requests to trigger data transfers. An example of a typical application is to use the eDMA to pass conversion commands to the analog to digital converter (ADC) whilst maintaining circular buffers of the ADC results in the system RAM, with no core intervention.

The Performance Optimization Checklist in the next section provides several system level examples of how to optimize an application.

33.6 Performance Optimization Checklist

| 1. Hardware Configuration | | |
|---------------------------|--|--|
| Description | Register(s) | Details |
| Branch Target Buffer | Flush with BUCSR[BBFI] Enable with BUCSR[BPEN] | Flush and enable to improve accuracy of branch predictions. |
| Branch Prediction | BUCSR[BPRED] BUCSR[BALLOC] | Consider fine tuning of BTB operation for specific applications. |
| System Frequency | FMPLL_ESYNCR1 FMPLL_ESYNCR2 | Select desired frequency taking into account the performance impact of additional wait states. |
| Flash Wait States | BIUCR[APC, WW, RWSC] | Refer to Section 12.2.2.8, Flash Bus Interface Configuration Register (FLASH_BIUCR) , for BIUCR settings for FMPLL frequency ranges. |
| Flash Prefetching | BIUCR[DPFEN, IPFEN, PFLIM, BFEN] | Enable prefetching for instructions. Prefetching for data should be assessed for the specific application. |
| Flash Prefetch Algorithm | BIUCR2[LBCFG] | Allocate buffers to data and/or instructions. Fine tune for specific applications. |
| Crossbar Switch | Park slave SRAM on master port with XBAR_SGPCR2. Set Flash slave port to highest priority with XBAR_MPRO. | For e200z7 based devices reconfigure to optimize for Harvard architecture. |
| Cache | Invalidate Icache with L1CSR1[ICINV] Enable Icache with L1CSR1[ICE] Invalidate Dcache with L1CSR0[DCINV] Enable Dcache with L1CSR0[DCE] | Invalidate and the enable the cache for instructions. Assess in application best configuration for using cache with data. Make an application dependent decision on copyback operation and store/push buffer configuration. |
| Memory Management Unit | TLB_MAS2[VLE, I] | Configure relevant pages for cache and VLE by setting MMU TLB attributes. |

| 2. Software Configuration | | |
|--|----------------------------|---|
| Description | Registers | Details |
| Compiler optimization | N/A | Use the features of the compiler to select the optimum trade off between code size and performance improvements. |
| Hardware Single Precision Floating Point | Enable with MSR[SPE] | Set compiler switches to specify using hardware single precision floating point as opposed to software emulation. |
| Signal Processing Extensions | Enable with MSR[SPE] | Take advantage of the SPE-APU to encode time critical functions using SPE assembly code. |
| Variable Length Encoding | Enabled with TLB_MAS2[VLE] | Set compiler switches and configure the MMU to take advantage of the VLE-APU. |

| 3. Peripherals and General Application Guidelines |
|--|
| <ul style="list-style-type: none"> • Use the eDMAs rather than the core to move data where possible. Most peripherals can generate eDMA requests to shift data. <ul style="list-style-type: none"> — Use the eDMAs to control movement of commands and results from ADC and to maintain circular buffers in system memory. — Create circular buffers so that ADC results can be stored in RAM with no core overhead. |
| <ul style="list-style-type: none"> • Shift loading from the CPU to the eTPU2 whenever possible. <ul style="list-style-type: none"> — The eTPU2 can provide effective CPU off-loading for time & angle based operations. — The eTPU2 can trigger the ADC directly with no need for CPU interruption. |
| <ul style="list-style-type: none"> • Avoid software polling and allow peripherals to trigger interrupts or request eDMA servicing. <ul style="list-style-type: none"> — Use hardware instead of software vectored interrupts to reduce latency. — Trigger eDMA requests rather than interrupting the CPU to move data/results. |
| <ul style="list-style-type: none"> • Configure the external memory interface. <ul style="list-style-type: none"> — Enable bursting on the external bus. — Reduce external bus wait states from default maximum settings. — Place time critical functions in internal memory. — Small, but frequently executed routines can be considered as candidates to be locked in cache. |

Chapter 34

Temperature Sensor

34.1 Overview

PXR40 MCUs include an on-board temperature sensor that monitors device temperature and produces a voltage directly proportional to the internal junction temperature. Internal junction temperature must be calculated by software based on the sampled temperature sensor voltage, sampled bandgap voltage and calibration parameter values stored in internal flash memory.

34.2 Detailed Description

The temperature sensor generates a voltage that increases linearly with temperature. Since the voltage is an amplified version of a ΔV_{BE} voltage it is proportional to absolute temperature. This voltage, $V_{TSENS}(T)$, is read by software using the on-board eQADC module and used with the bandgap voltage and constants stored in flash memory during factory test to calculate device junction temperature.

Five calibration parameters are stored in flash memory during factory test:

- T_{LOW} is the low temperature factory calibration temperature value.
- T_{HIGH} is the hot factory calibration temperature value.
- $V_{BG_CODE}(T_{LOW})$ is the bandgap voltage at low calibration temperature (T_{LOW}) sampled by the eQADC and converted to a 14-bit value.
- $T_{TSENS_CODE}(T_{LOW})$ is the temperature sensor voltage at low calibration temperature (T_{LOW}) sampled by the eQADC and converted to a 14-bit value.
- $T_{TSENS_CODE}(T_{HIGH})$ is the temperature sensor voltage at high calibration temperature (T_{HIGH}) sampled by the eQADC and converted to a 14-bit value.

The calibration points are illustrated in [Figure 34-1](#).

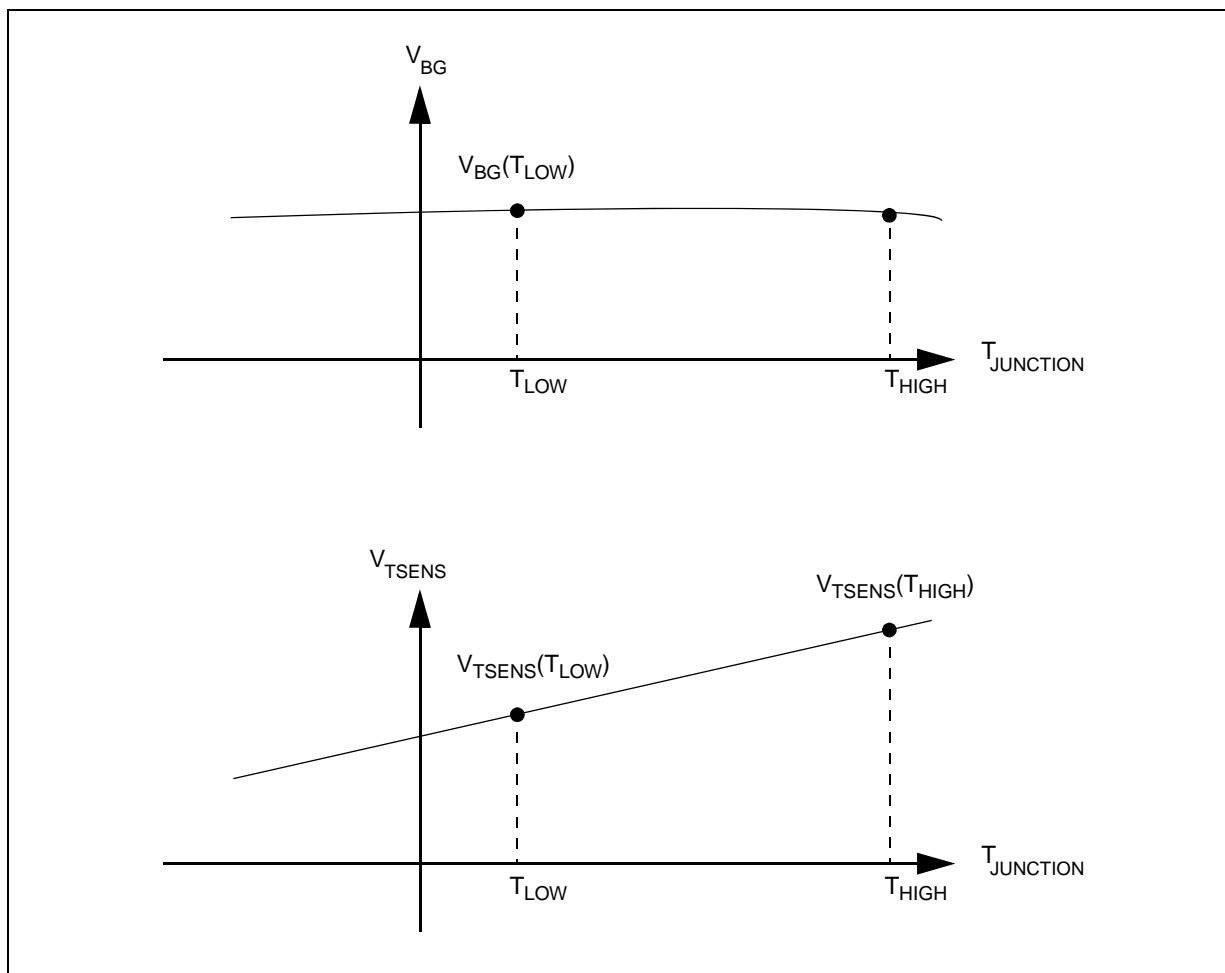

Figure 34-1. Calibration Points

34.3 Temperature formula

The temperature formula is shown in [Figure 34-2](#).

$$T = T_{\text{LOW}} + \frac{T_{\text{TSENS_CODE}}(T) \times \beta - T_{\text{TSENS_CODE}}(T_{\text{LOW}})}{T_{\text{TSENS_CODE}}(T_{\text{HIGH}}) - T_{\text{TSENS_CODE}}(T_{\text{LOW}})} \times (T_{\text{HIGH}} - T_{\text{LOW}})$$

where:

$$T_{\text{TSENS_CODE}}(T_{\text{LOW}}) = \frac{V_{\text{TSENS}}(T_{\text{LOW}})}{V_{\text{ref0}}} \times 2^{14} \quad (\text{Stored in device flash during factory calibration})$$

$$T_{\text{TSENS_CODE}}(T_{\text{HIGH}}) = \frac{V_{\text{TSENS}}(T_{\text{HIGH}})}{V_{\text{ref0}}} \times 2^{14} \quad (\text{Stored in device flash during factory calibration})$$

$$V_{\text{BG_CODE}}(T_{\text{LOW}}) = \frac{V_{\text{BG}}(T_{\text{LOW}})}{V_{\text{ref0}}} \times 2^{14} \quad (\text{Stored in device flash during factory calibration})$$

$$V_{\text{BG_CODE}}(T) = \frac{V_{\text{BG}}(T)}{V_{\text{ref}}} \times 2^{14}$$

$$T_{\text{TSENS_CODE}}(T) = \frac{V_{\text{TSENS}}(T)}{V_{\text{ref}}} \times 2^{14}$$

$$\beta = \frac{V_{\text{BG_CODE}}(T_{\text{LOW}})}{V_{\text{BG_CODE}}(T)}$$

Notes:

- $V_{\text{TSENS}}(T)$ is the temperature sensor output sampled by the ADC
- $V_{\text{BG}}(T)$ is the bandgap voltage sampled by the ADC
- V_{ref} is the ADC reference voltage
- V_{ref0} is the ADC reference voltage during factory calibration
- T_{LOW} is the low temperature factory calibration temperature (stored in device flash)
- T_{HIGH} is the hot factory calibration temperature (stored in device flash)

Figure 34-2. Temperature formula

The following sections detail the values required and where to get them.

34.3.1 T_{LOW} and T_{HIGH}

T_{LOW} is the factory low calibration temperature; T_{HIGH} is the hot factory calibration temperature. These values are stored in shadow flash memory during factory calibration. See [Section 34.3.6.1, Temperature Calculation Constants Register 0](#), for details.

34.3.2 $T_{\text{TSENS_CODE}}(T_{\text{LOW}})$ and $T_{\text{TSENS_CODE}}(T_{\text{HIGH}})$

$T_{\text{TSENS_CODE}}(T_{\text{LOW}})$ is the sampled output voltage of the temperature sensor during low temperature factory calibration. $T_{\text{TSENS_CODE}}(T_{\text{HIGH}})$ is the sampled output voltage of the temperature sensor during hot temperature factory calibration. These values are stored in shadow flash memory during factory calibration. See [Section 34.3.6.1, Temperature Calculation Constants Register 0](#), for details.

34.3.3 $V_{BG_CODE}(T_{LOW})$

$V_{BG_CODE}(T_{LOW})$ is the value of the bandgap voltage sampled during low temperature factory calibration. This value is stored in shadow flash memory during factory calibration. See [Section 34.3.6.2, Temperature Calculation Constants Register 1](#), for details.

34.3.4 Temperature sensor voltage ($V_{TENS}(T)$)

$V_{TENS}(T)$ is the output voltage of the device temperature sensor. Software must sample the voltage from eQADC_A channel 128 (ADC0 and ADC1).

34.3.5 Bandgap reference voltage ($V_{BG_CODE}(T)$)

V_{BG} is the bandgap reference voltage. Software must sample the voltage from eQADC_A channel 145 (ADC0).

34.3.6 Registers

The calibration constants described previously, i.e., T_{LOW} , T_{HIGH} , $T_{SENS_CODE}(T_{LOW})$, $T_{SENS_CODE}(T_{HIGH})$ and $V_{BG_CODE}(T_{LOW})$, are stored in device shadow flash memory during factory test. This section details the registers where the values reside.

34.3.6.1 Temperature Calculation Constants Register 0

This register contains the calibration temperatures and temperature sensor outputs measured during factory calibration:

- T_{HIGH}
- $T_{SENS_CODE}(T_{HIGH})$
- T_{LOW}
- $T_{SENS_CODE}(T_{LOW})$

Address: **0xFFFE_C000**

| | | | | | | | | | | | | | | | | |
|--------|-------|---|-------|---|---|---|---|---|---|---|----|----|----|----|----|----|
| | 0 | 1 | 2 | 3 | 4 | 5 | 6 | 7 | 8 | 9 | 10 | 11 | 12 | 13 | 14 | 15 |
| R | THIGH | | TSCV2 | | | | | | | | | | | | | |
| W | | | | | | | | | | | | | | | | |
| RESET: | x | x | x | x | x | x | x | x | x | x | x | x | x | x | x | x |

| | | | | | | | | | | | | | | | | |
|--------|------|----|-------|----|----|----|----|----|----|----|----|----|----|----|----|----|
| | 16 | 17 | 18 | 19 | 20 | 21 | 22 | 23 | 24 | 25 | 26 | 27 | 28 | 29 | 30 | 31 |
| R | TLOW | | TSCV1 | | | | | | | | | | | | | |
| W | | | | | | | | | | | | | | | | |
| RESET: | x | x | x | x | x | x | x | x | x | x | x | x | x | x | x | x |

= Unimplemented or Reserved

Figure 34-3. Temperature Calculation Constants Register 0

The bit fields are described in [Table 34-1](#)

Table 34-1. Temperature Calculation Constants Register 0 Field Descriptions

| Field | Description |
|----------------|---|
| 0–1 THIGH | The THIGH field contains a value indicating the hot factory calibration temperature (T_{HIGH}). The values are as follows: 00: T_{HIGH} = Reserved 01: T_{HIGH} = Reserved 10: T_{HIGH} = 145 °C 11: T_{HIGH} = 150 °C |
| 2–15 TSCV2 | Temperature sensor output at hot factory calibration temperature ($TSENS_CODE(T_{HIGH})$). TSCV2 is the temperature sensor voltage sampled and converted by the eQADC during factory test with device at hot temperature (T_{HIGH}). This is the $TSENS_CODE(T_{HIGH})$ parameter value referenced in the temperature calculation formula (see Figure 34-2). |
| 16–17 TLOW | The TLOW field contains a code indicating the low factory calibration temperature (T_{LOW}). The values are as follows: 00: T_{LOW} = 25 °C 01: T_{LOW} = 40 °C 10: T_{LOW} = Reserved 11: T_{LOW} = Reserved |
| 18–31 TSCV1 | Temperature sensor output at the low factory calibration temperature ($TSENS_CODE(T_{LOW})$). TSCV1 is the temperature sensor voltage sampled and converted by the eQADC during factory test with device at the low calibration temperature. This is the $TSENS_CODE(T_{LOW})$ parameter value referenced in the temperature calculation formula (see Figure 34-2). |

34.3.6.2 Temperature Calculation Constants Register 1

This register contains the $V_{BG_CODE}(T_{LOW})$ parameter value used in the temperature calculation.

Address: **0xFFFE_C004**

| | | | | | | | | | | | | | | | | |
|--------|----------|----|-------|----|----|----|----|----|----|----|----|----|----|----|----|----|
| | 0 | 1 | 2 | 3 | 4 | 5 | 6 | 7 | 8 | 9 | 10 | 11 | 12 | 13 | 14 | 15 |
| R | Reserved | | TSCV3 | | | | | | | | | | | | | |
| W | Reserved | | TSCV3 | | | | | | | | | | | | | |
| RESET: | 0 | 0 | x | x | x | x | x | x | x | x | x | x | x | x | x | x |
| | 16 | 17 | 18 | 19 | 20 | 21 | 22 | 23 | 24 | 25 | 26 | 27 | 28 | 29 | 30 | 31 |
| R | Reserved | | | | | | | | | | | | | | | |
| W | Reserved | | | | | | | | | | | | | | | |
| RESET: | 0 | 0 | 0 | 0 | 0 | 0 | 0 | 0 | 0 | 0 | 0 | 0 | 0 | 0 | 0 | 0 |

 = Unimplemented or Reserved

Figure 34-4. Temperature Calculation Constants Register 1

The bit fields are described in [Table 34-2](#)

Table 34-2. Temperature Calculation Constants Register 1 Field Descriptions

| Field | Description |
|---------------|---|
| 0–1 | Reserved |
| 2–15 TSCV3 | Bandgap voltage sampled and converted by ADC during factory test. This is the $V_{BG_CODE}(T_{LOW})$ parameter value referenced in the temperature calculation formula (see Figure 34-2). |
| 16–31 | Reserved |

Appendix A

Revision History of this Document

A.1 Revisions

This appendix describes corrections to the *PXR40 Microcontroller Reference Manual (PXR40RM)*. For convenience, the corrections are grouped by revision.

Since this is the first revision of this document, no changes are listed.

Table A-1. Revision history

| Date | Revision | Changes |
|--------------|----------|------------------|
| 30 June 2011 | 1 | Initial release. |