

# MOTOROLA EC603e™ MICROPROCESSOR

The Motorola EC603e microprocessor (Motorola order number MPE603e) is a PowerPC™ processor optimized for embedded applications. The EC603e microprocessor offers workstation-level performance packed into a low-power, low-cost design ideal for telecommunications systems, networking and communications infrastructure, and industrial controls. The EC603e microprocessor is functionally identical to the widely used PowerPC 603e™ microprocessor, except floating point operations are not hardware accelerated on the EC603e microprocessor. The EC603e microprocessor is software- and bus-compatible with the PowerPC 603e, PowerPC 604e™, PowerPC 740™ and PowerPC 750™ microprocessor families.

## Superscalar Microprocessor

The EC603e microprocessor is a superscalar design capable of issuing three instructions per clock cycle into four independent execution units, including:

- Integer unit
- System register unit
- Load/Store unit
- Branch processing unit

The ability to execute multiple instructions in parallel, to pipeline instructions, and the use of simple instructions with rapid execution times yields maximum efficiency and throughput for systems based on the EC603e microprocessor.

## Power Management

The EC603e microprocessor features a low-power 2.5-volt or 3.3-volt design with three power-saving modes—doze, nap and sleep. These user-programmable modes progressively reduce the power drawn by the processor. The EC603e microprocessor also uses dynamic power management to selectively activate functional units as they are needed by the executing instructions. Unused functional units enter a low-power state automatically without affecting performance, software execution, or external hardware.

## Cache and MMU Support

The EC603e microprocessor has separate 16-Kbyte, physically-addressed instruction and data caches. Both caches are four-way set-associative.

**EC603e Microprocessor Block Diagram**

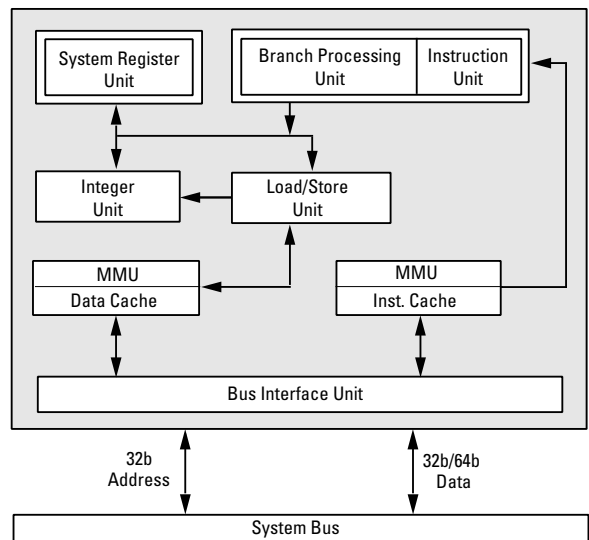

Freescale Semiconductor, Inc.

The EC603e microprocessor also contains separate memory management units (MMUs) for instructions and data. The MMUs support 4 Petabytes ( $2^{52}$ ) of virtual memory and 4 Gigabytes ( $2^{32}$ ) of physical memory. Access privileges and memory protection are controlled on block or page granularities. Large, 64-entry translation lookaside buffers (TLBs) provide efficient physical address translation and support for demand virtual-memory management on both page- and variable-sized blocks.

## Flexible Bus Interface

The EC603e microprocessor has a selectable 32- or 64-bit data bus and a 32-bit address bus. Support is included for burst, split and pipelined transactions. The interface provides snooping for data cache coherency. The EC603e microprocessor maintains MEI coherency protocol in hardware, allowing access to system memory for additional caching bus masters, such as DMA devices.

## EC603e CPU Summary

CPU	EC603e 100-133 MHz	EC603e 166-200 MHz	EC603e 166-300 MHz
CPU Speeds - Internal	100 and 133 MHz	166 and 200 MHz	166, 200, 233, 266 and 300 MHz
CPU Bus Dividers	x1.5, x2, x2.5, x3, x3.5, x4	x2, x2.5, x3, x3.5, x4, x4.5, x5, x5.5, x6	x2, x2.5, x3, x3.5, x4, x4.5, x5, x5.5, x6
Bus Interface	64-bit data & 32-bit address	64-bit data & 32-bit address	64-bit data & 32-bit address
Instructions per Clock	3 (2 + Branch)	3 (2 + Branch)	3 (2 + Branch)
L1 Cache	16-Kbyte instruction 16-Kbyte data	16-Kbyte instruction 16-Kbyte data	16-Kbyte instruction 16-Kbyte data
Typical/Maximum Power Dissipation	4.2W/5.3W @ 133 MHz	4.0W/5.0W @ 200 MHz	4.0W/6.0W @ 300 MHz
Package	240 CQFP, 255 CBGA	240 CQFP, 255 CBGA	255 CBGA
Process	0.5 $\mu$ 4LM CMOS	0.35 $\mu$ 5LM CMOS	0.29 $\mu$ 5LM CMOS
Transistors	2.6 million	2.6 million	2.6 million
Voltage	3.3V	3.3V i/o, 2.5V internal	3.3V i/o, 2.5V internal
SPECint95 (estimated)	3.9 @ 133 MHz	5.6 @ 200 MHz	7.4 @ 300 MHz
Other Performance	188 MIPS @ 133 MHz	283 MIPS @ 200 MHz	423 MIPS @ 300 MHz
Execution Units	Integer, Branch, Load/Store, System Register	Integer, Branch, Load/Store, System Register	Integer, Branch, Load/Store, System Register

For additional information:  
call 1-800-845-6686 or your local Motorola sales representative  
or visit <http://motorola.com/PowerPC/>