

# MPC8315E-RDB Reference Platform

## Overview

The MPC8315E-RDB reference platform is ideal for hardware and software development of the two-drive consumer network attached storage (NAS) and the digital media server. The cost-effective MPC8315E communications processor family meets the requirements of several small office/home office (SOHO), triple-play converged residential gateway and industrial control applications. It leverages Freescale's highly integrated MPC8315E processor, built on Power Architecture® technology, and leading-edge external components—2 x Gigabit Ethernet, 4 x USB, 2 x Serial ATA (SATA), dual Legerity SLIC, PCI Express®, mini Express Connector and an Ethernet connection to broadband powerline capability using DS2. The high level of integration in the MPC8315E helps to lower overall system costs, improve performance and simplify board design. The MPC8315E microprocessor supports dual 10/100/1000 Mbps Ethernet controllers, single 64-bit PCI controller, 2 x PCI Express, integrated security engine, USB 2.0 with PHY integrated, 4-channel direct memory access (DMA), dual universal asynchronous receiver/transmitter (DUART), serial peripherals, general-purpose I/O and system timers.

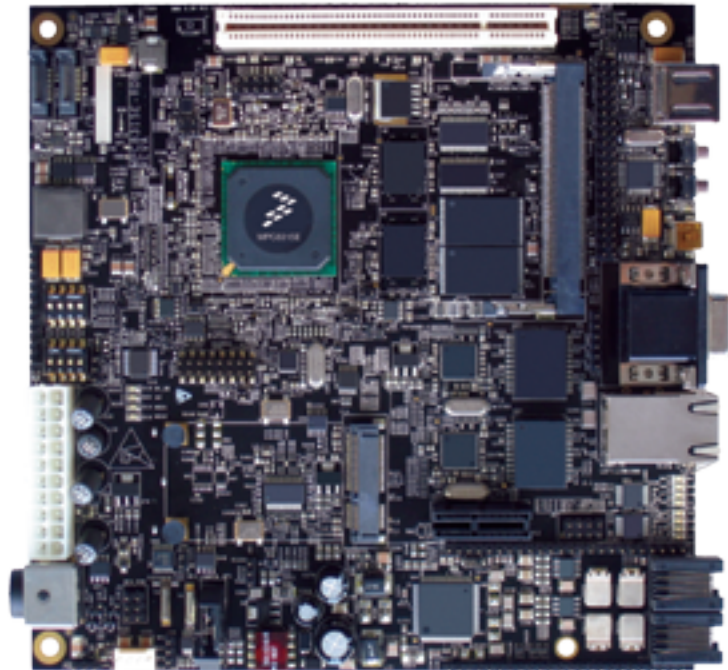

A board support package (BSP) is pre-installed on the MPC8315E-RDB. This BSP includes a bootloader (u-boot)—a generic Power Architecture technology system based on the Linux® kernel. The u-boot and Linux kernel reside in the on-board flash memory.

On powering up, the Linux system runs on the MPC8315E-RDB. The MPC8315E-RDB BSP generation takes advantage of the Linux Target Image Builder (LTIB)—a suite of tools that leverages existing open source configuration scripts and source code packages and bundles them all into a single BSP generation bundle. The source code packages include boot loaders and Linux kernel sources, as well as many user-space source code packages, to build a complete

BSP. The LTIB also provides compiler packages required to build the BSP. Freescale developers use the LTIB to create BSPs for a multitude of Freescale development markets. The LTIB leverages as many BSP elements as possible for all Freescale markets supported, while offering the flexibility necessary to customize components that require platform-specific modifications. Many third-party applications are available for the MPC8315E-RDB. They are typically built on top of the BSP delivered by Freescale and are installed on the hard disk. To see demonstrations or to acquire details of Freescale's third-party applications for this platform, please contact your local Freescale sales office.

## Features

- CPU: Freescale MPC8315E running at 400/266 MHz (CPU/DDR2)
- Ethernet
  - Two Gigabit RGMII connections directly to PHY
  - One Ethernet connection to broadband powerline capability using DS2
- PCI Express
  - PCI Express add-in connector
  - MiniPCI Express for WLAN
- SATA
  - Two standard SATA connectors
  - eSATA will be available through SATA-eSATA connectors
- SPI/TDM
  - Connected to dual Legerity SLIC/SLAC
- I<sup>2</sup>C
  - Connected to real-time clock
  - May be eliminated using the MCU
- Dual UART
  - Connectors for debug connectivity
  - Extra header (compliant to MPC832x RDB) for Bluetooth<sup>®</sup>/ZigBee<sup>®</sup> future connectivity
- Local bus
  - NAND flash/NOR flash memory
- High speed
  - Connector directly on board
  - 3-port USB hub
- PCI
  - One standard and one MiniPCI connector
- Memory
  - 32-bit DDR2 with population option for 16-bit

## MPC8315E-RDB Block Diagram

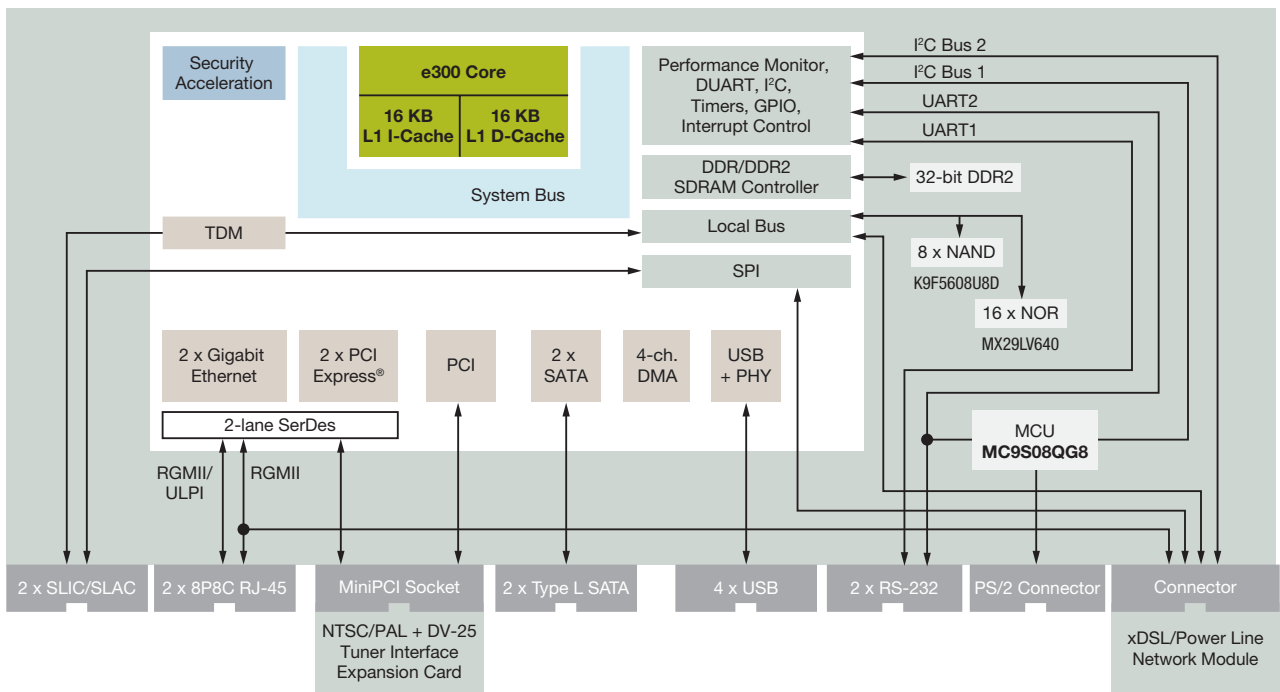

■ Core ■ Accelerators ■ I/O ■ Connector or Slot

**Learn More:** For current information about Freescale products and documentation, please visit [www.freescale.com/storage](http://www.freescale.com/storage).



Freescale and the Freescale logo are trademarks or registered trademarks of Freescale Semiconductor, Inc. in the U.S. and other countries. All other product or service names are the property of their respective owners. The Power Architecture and Power.org word marks and the Power and Power.org logos and related marks are trademarks and service marks licensed by Power.org. © Freescale Semiconductor, Inc. 2009.

Document Number: MPC8315ERDBFS  
REV 3 cc

