

# PCA85074A

## Tiny Real-Time Clock/Calendar with Alarm Function and I<sup>2</sup>C-Bus

Rev. 2.0 — 4 June 2026

Product data sheet



## 1 General description

---

The PCA85074A is a CMOS<sup>1</sup> Real-Time Clock (RTC) and calendar optimized for low power consumption and operating temperature up to 125 °C. An offset register allows fine-tuning of the clock. All addresses and data are transferred serially via the two-line bidirectional I<sup>2</sup>C-bus. The maximum data rate is 400 kbit/s. The register address is incremented automatically after each written or read data byte.

## 2 Features and benefits

---

- AEC-Q100 (Grade 1) compliant (PCA85074ADP/Q900)
- Provides year, month, day, weekday, hours, minutes, and seconds based on a 32.768 kHz quartz crystal
- Low current; typical 0.25 µA at V<sub>DD</sub> = 3.0 V and T<sub>amb</sub> = 25 °C
- Programmable clock output for peripheral devices (32.768 kHz, 16.384 kHz, 8.192 kHz, 4.096 kHz, 2.048 kHz, 1.024 kHz, and 1 Hz)
- Alarm function
- Minute and a half minute interrupt
- Internal Power-On Reset (POR)
- High temperature operation range: -40 °C to +125 °C
- Clock operating voltage: 0.9 V to 5.5 V
- 400 kHz two-line I<sup>2</sup>C-bus interface (at V<sub>DD</sub> = 1.8 V to 5.5 V)
- Selectable integrated oscillator load capacitors for C<sub>L</sub> = 7 pF or C<sub>L</sub> = 12.5 pF
- Countdown timer
- Oscillator stop detection function
- Programmable offset register for frequency adjustment
- Latch-up performance exceeds 100 mA per JESD 78, Class II
- ESD protection exceeds JESD 22
  - 4000 V Human-Body Model (A114-A)
  - 1000 V Charged-Device Model (C101)
- Package offered: TSSOP8

## 3 Applications

---

- Tracking time of the day
- Accurate timing

---

<sup>1</sup> The definition of the abbreviations and acronyms used in this data sheet can be found in [Section 20](#).



- Digital cluster
- Infotainment unit
- HVAC
- Center stack
- Telematics
- Body control and battery management

## 4 Ordering information

[Table 1](#) describes the ordering information for PCA85074A.

**Table 1. Ordering information**

Type number	Topside marking	Package		
		Name	Description	Version
PCA85074ADP	074A	TSSOP8	Plastic thin shrink small outline package; 8 leads; body width 3 mm	SOT505-1
PCA85074ADP/Q900	074Q	TSSOP8	Plastic thin shrink small outline package; 8 leads; body width 3 mm	SOT505-1

### 4.1 Ordering options

[Table 2](#) describes the ordering options for PCA85074A.

**Table 2. Ordering options**

Type number	Orderable part number	Package	Packing method	Minimum order quantity	Temperature
PCA85074ADP	PCA85074ADPZ	TSSOP8	REEL 13" Q1 NDP SSB <sup>[1]</sup>	2500	T <sub>amb</sub> = -40 °C to +125 °C
PCA85074ADP/Q900	PCA85074ADP/Q900Z	TSSOP8	REEL 13" Q1 NDP SSB <sup>[1]</sup>	2500	T <sub>amb</sub> = -40 °C to +125 °C

[1] This packing method uses a Static Shielding Bag (SSB) solution. Material is kept in a sealed bag between uses.

### 5 Block diagram

Figure 1 shows the labeled block diagram of PCA85074A.

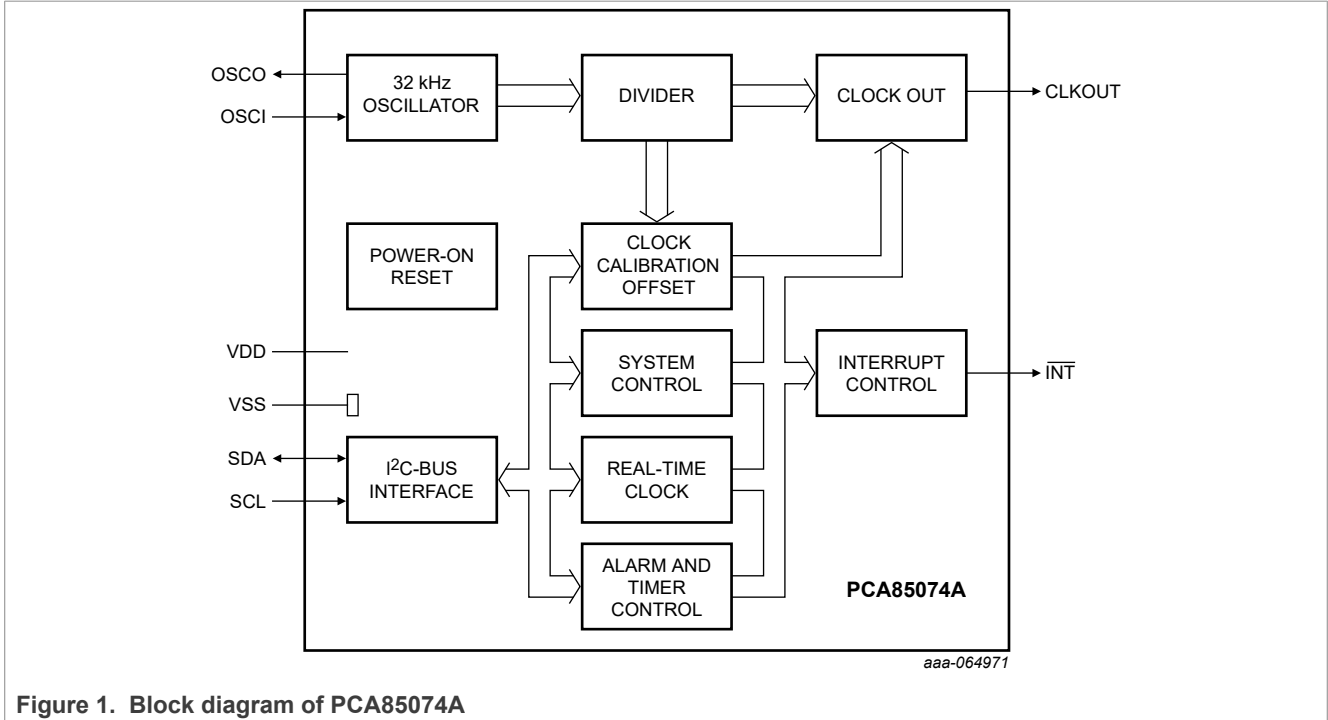

Figure 1. Block diagram of PCA85074A

### 6 Pinning information

This section provides the pin configuration and description of PCA85074A.

#### 6.1 Pinning

Figure 2 shows the pin configuration of PCA85074A.

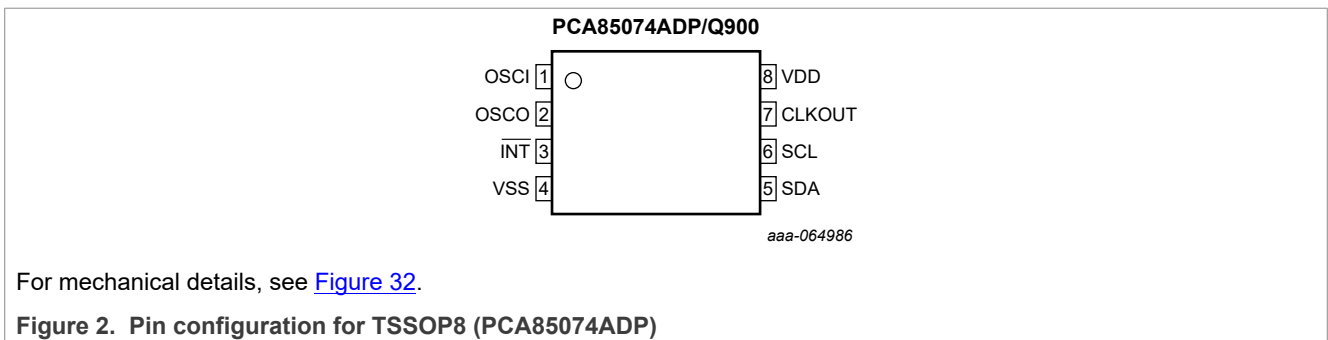

For mechanical details, see Figure 32.

Figure 2. Pin configuration for TSSOP8 (PCA85074ADP)

## 6.2 Pin description

Table 3 provides detailed description of various pins on PCA85074A.

Table 3. Pin description

Input or input/output pins must always be at a defined level ( $V_{SS}$  or  $V_{DD}$ ) unless otherwise specified.

Symbol	Pin	Type	Description
OSCI	1	Input	Oscillator input
OSCO	2	Output	Oscillator output
$\overline{\text{INT}}^{[1]}$	3	Output	Interrupt output (open-drain)
VSS	4	Supply	Ground supply voltage
SDA <sup>[1]</sup>	5	Input/output	Serial data line
SCL <sup>[1]</sup>	6	Input	Serial clock input
CLKOUT	7	Output	Clock output (push-pull)
VDD	8	Supply	Supply voltage

[1] NXP recommends tying the VDD of the device and VDD of all the external pullup resistors to the same power supply.

## 7 Functional description

The PCA85074A contains 18 8-bit registers with an auto-incrementing register address, an on-chip 32.768 kHz oscillator with integrated capacitors, a frequency divider, which provides the source clock for the RTC and calendar, and an I<sup>2</sup>C-bus interface with a maximum data rate of 400 kbit/s.

The built-in address register will increment automatically after each read or write of a data byte up to the register 11h. After register 11h, the auto-incrementing will wrap around to address 00h (see Figure 3).

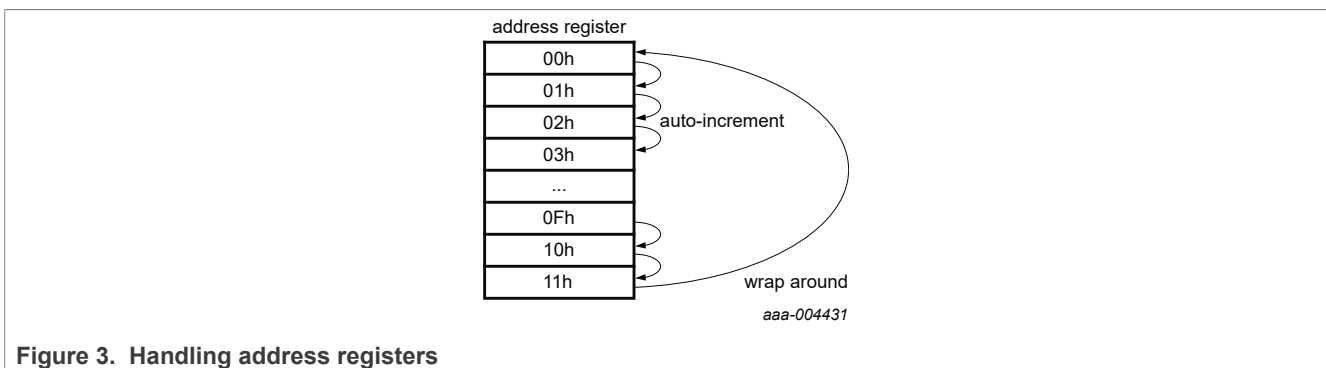

Figure 3. Handling address registers

All registers (see Table 4) are designed as addressable 8-bit parallel registers although not all bits are implemented. The first two registers (memory address 00h and 01h) are used as control and status register. The register at address 02h is an offset register allowing the fine-tuning of the clock; and at 03h is a free RAM byte. The addresses 04h through 0Ah are used as counters for the clock function (seconds up to years counters). Address locations 0Bh through 0Fh contain alarm registers, which define the conditions for an alarm. The registers at 10h and 11h are for the timer function.

The Seconds, Minutes, Hours, Days, Months, and Years and the corresponding alarm registers are all coded in Binary Coded Decimal (BCD) format. When one of the RTC registers is written or read, the contents of all-time counters are frozen. Therefore, faulty writing or reading of the clock and calendar during a carry condition be prevented. For details on maximum access time, see Section 7.4.

## 7.1 Registers organization

Table 4 lists all the registers used for PCA85074A.

**Table 4. Registers overview**

Bit positions labeled as - are not implemented. After reset, all registers are set according to Table 7.

Address	Register name	Bit								Reference	
		7	6	5	4	3	2	1	0		
<b>Control and status registers</b>											
00h	Control_1	EXT_TEST	-	STOP	SR	-	CIE	12_24	CAP_SEL	<a href="#">Section 7.2.1</a>	
01h	Control_2	AIE	AF	MI	HMI	TF	COF[2:0]			<a href="#">Section 7.2.2</a>	
02h	Offset	MODE	OFFSET[6:0]								<a href="#">Section 7.2.3</a>
03h	RAM_byte	B[7:0]								<a href="#">Section 7.2.4</a>	
<b>Time and date registers</b>											
04h	Seconds	OS	SECONDS (0 to 59)								<a href="#">Section 7.3.1</a>
05h	Minutes	-	MINUTES (0 to 59)								<a href="#">Section 7.3.2</a>
06h	Hours	-	-	AMPM	HOURS (1 to 12) in 12-hour mode					<a href="#">Section 7.3.3</a>	
				HOURS (0 to 23) in 24-hour mode							
07h	Days	-	-	DAYS (1 to 31)					<a href="#">Section 7.3.4</a>		
08h	Weekdays	-	-	-	-	-	WEEKDAYS (0 to 6)			<a href="#">Section 7.3.5</a>	
09h	Months	-	-	-	MONTHS (1 to 12)					<a href="#">Section 7.3.6</a>	
0Ah	Years	YEARS (0 to 99)								<a href="#">Section 7.3.7</a>	
<b>Alarm registers</b>											
0Bh	Second_alarm	AEN_S	SECOND_ALARM (0 to 59)								<a href="#">Section 7.5.1</a>
0Ch	Minute_alarm	AEN_M	MINUTE_ALARM (0 to 59)								<a href="#">Section 7.5.2</a>
0Dh	Hour_alarm	AEN_H	-	AMPM	HOUR_ALARM (1 to 12) in 12-hour mode					<a href="#">Section 7.5.3</a>	
				HOUR_ALARM (0 to 23) in 24-hour mode							
0Eh	Day_alarm	AEN_D	-	DAY_ALARM (1 to 31)							<a href="#">Section 7.5.4</a>
0Fh	Weekday_alarm	AEN_W	-	-	-	-	WEEKDAY_ALARM (0 to 6)			<a href="#">Section 7.5.5</a>	
<b>Timer registers</b>											
10h	Timer_value	T[7:0]									<a href="#">Section 7.6.1</a>
11h	Timer_mode	-	-	-	TCF[1:0]		TE	TIE	TI_TP	<a href="#">Section 7.6.2</a>	

## 7.2 Control registers

To ensure that all control registers are set to their default values, the V<sub>DD</sub> level must be at zero volts at initial power up. If this is not possible, a reset must be initiated with the software reset command when power is stable. Refer to [Section 7.2.1.2](#) for details.

### 7.2.1 Register Control\_1

Table 5 describes the bit configuration of the Control\_1 register.

**Table 5. Control\_1 - control and status register 1 (address 00h) bit description**

Bit	Symbol	Value	Description	Reference
7	-	0	Unused	-
6	-	0	Unused	-
5	STOP		<b>Stop bit</b>	<a href="#">Section 7.2.1.1</a>
		0 <sup>[1]</sup>	RTC clock runs	

Table 5. Control\_1 - control and status register 1 (address 00h) bit description...continued

Bit	Symbol	Value	Description	Reference
		1	The RTC clock is stopped; all RTC divider chain flip-flops are asynchronously set logic 0	
4	SR		<b>Software reset</b>	<a href="#">Section 7.2.1.2</a>
		0 <sup>[1]</sup>	No software reset	
		1	Initiate software reset <sup>[2]</sup> ; this bit always returns a 0 when read	
3	-	0	Unused	-
2	CIE		<b>Correction interrupt enable</b>	<a href="#">Section 7.2.3</a>
		0 <sup>[1]</sup>	No correction interrupt generated	
		1	Interrupt pulses are generated at every correction cycle	
1	12_24		<b>12 or 24-hour mode</b>	<a href="#">Section 7.3.3</a> <a href="#">Section 7.5.3</a>
		0 <sup>[1]</sup>	24-hour mode is selected	
		1	12-hour mode is selected	
0	CAP_SEL		<b>Internal oscillator capacitor selection</b> for quartz crystals with a corresponding load capacitance	-
		0 <sup>[1]</sup>	7 pF	
		1	12.5 pF	

[1] Default value.

[2] For a software reset, 0101 1000 (58h) must be sent to register Control\_1 (see [Section 7.2.1.2](#)).

7.2.1.1 STOP: Stop bit function

The function of the stop bit (see [Figure 4](#)) is to allow for accurate starting of the time circuits. The stop bit function causes the upper part of the prescaler (F<sub>2</sub> to F<sub>14</sub>) to be held in reset. Therefore, no 1 Hz ticks are generated. It also stops the output of clock frequencies below 8 kHz on pin CLKOUT.

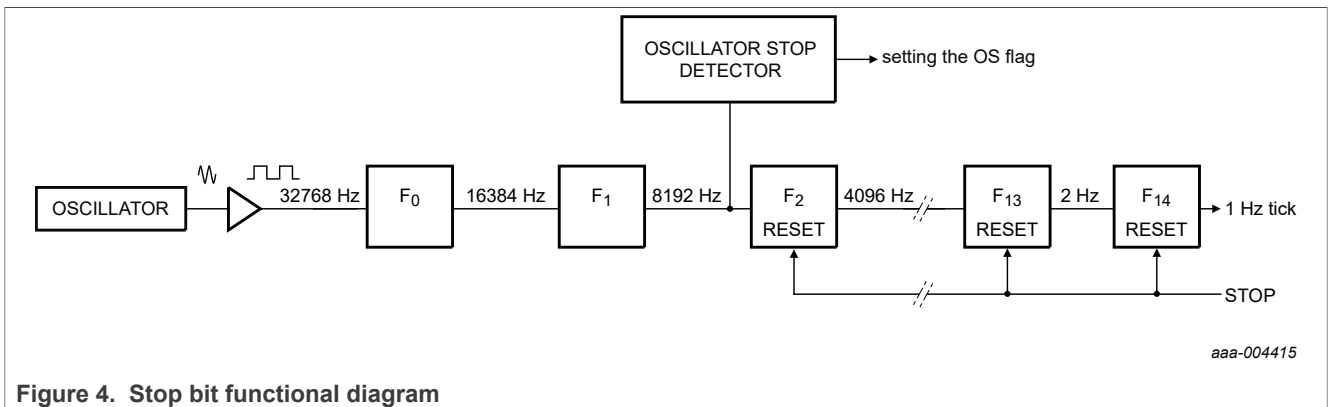

Figure 4. Stop bit functional diagram

The time circuits can then be set and do not increment until the stop bit is released (see [Figure 5](#) and [Table 6](#)).

Table 6. First increment of time circuits after stop bit release

Bit	Prescaler bits	[1]	1 Hz tick	Time	Comment
STOP	F <sub>0</sub> F <sub>1</sub> -F <sub>2</sub> to F <sub>14</sub>			hh:mm:ss	
<b>The clock is running normally</b>					
0	01-0 0001 1101 0100			12:45:12	Prescaler counting normally
<b>Stop bit is activated by the user. F<sub>0</sub>F<sub>1</sub> are not reset and values cannot be predicted externally</b>					
1	XX-0 0000 0000 0000			12:45:12	Prescaler is reset; time circuits are frozen
<b>A new time is set by the user</b>					
1	XX-0 0000 0000 0000			08:00:00	Prescaler is reset; time circuits are frozen
<b>Stop bit is released by the user</b>					
0	XX-0 0000 0000 0000		08:00:00	08:00:00	Prescaler is now running
	XX-1 0000 0000 0000		08:00:00	-	
	XX-0 1000 0000 0000		08:00:00	-	
	XX-1 1000 0000 0000		08:00:00	-	
	:		:	:	
	11-1 1111 1111 1110		08:00:00	-	
	00-0 0000 0000 0001		08:00:01	The 0 to 1 transition of F <sub>14</sub> increments the time circuits	
	10-0 0000 0000 0001		08:00:01	-	
	:		:	:	
	11-1 1111 1111 1111		08:00:01	-	
	00-0 0000 0000 0000		08:00:01	-	
	10-0 0000 0000 0000		08:00:01	-	
	:		:	:	
	11-1 1111 1111 1110		08:00:01	-	
00-0 0000 0000 0001	08:00:02	The 0 to 1 transition of F <sub>14</sub> increments the time circuits			

[1] F<sub>0</sub> is clocked at 32.768 kHz.

The lower two stages of the prescaler (F<sub>0</sub> and F<sub>1</sub>) are not reset. And because the I<sup>2</sup>C-bus is asynchronous to the crystal oscillator, the accuracy of restarting the time circuits is between zero and one 8.192 kHz cycle (see [Figure 5](#)).

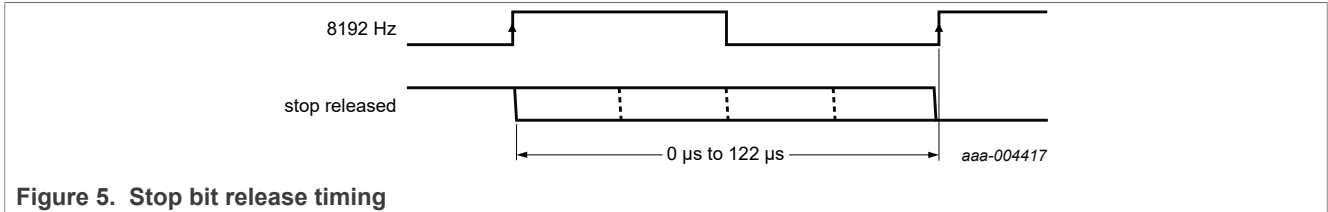
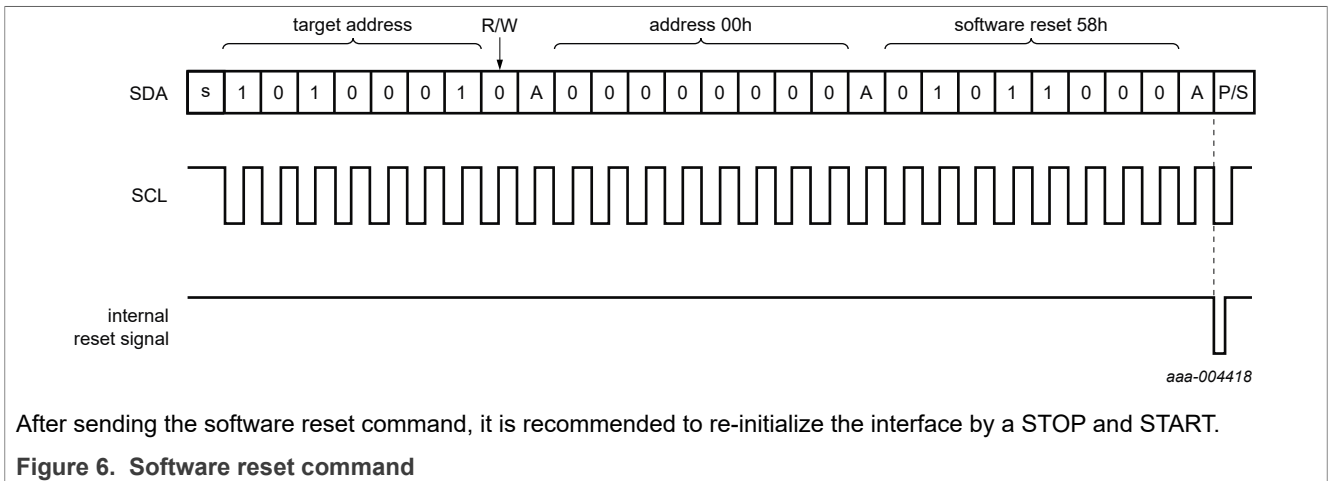

Figure 5. Stop bit release timing

The first increment of the time circuits is between 0.507 813 s and 0.507 935 s after stop bit is released. The uncertainty is caused by the prescaler bits F<sub>0</sub> and F<sub>1</sub> not being reset (see Table 6) and the unknown state of the 32 kHz clock.

7.2.1.2 Software reset

A reset is automatically generated at power on. A reset can also be initiated with the software reset command. Software reset command means setting bits 6, 4, and 3 in register Control\_1 (00h) logic 1 and all other bits logic 0 by sending the bit sequence 0101 1000 (58h), see Figure 6.



After sending the software reset command, it is recommended to re-initialize the interface by a STOP and START.

Figure 6. Software reset command

In reset state, all registers are set according to Table 7 and the address pointer returns to address 00h.

Table 7. Registers reset values

Address	Register name	Bit							
		7	6	5	4	3	2	1	0
00h	Control_1	0	0	0	0	0	0	0	0
01h	Control_2	0	0	0	0	0	0	0	0
02h	Offset	0	0	0	0	0	0	0	0
03h	RAM_byte	0	0	0	0	0	0	0	0
04h	Seconds	1	0	0	0	0	0	0	0
05h	Minutes	0	0	0	0	0	0	0	0
06h	Hours	0	0	0	0	0	0	0	0
07h	Days	0	0	0	0	0	0	0	1
08h	Weekdays	0	0	0	0	0	1	1	0
09h	Months	0	0	0	0	0	0	0	1
0Ah	Years	0	0	0	0	0	0	0	0

Table 7. Registers reset values...continued

Address	Register name	Bit							
		7	6	5	4	3	2	1	0
0Bh	Second_alarm	1	0	0	0	0	0	0	0
0Ch	Minute_alarm	1	0	0	0	0	0	0	0
0Dh	Hour_alarm	1	0	0	0	0	0	0	0
0Eh	Day_alarm	1	0	0	0	0	0	0	0
0Fh	Weekday_alarm	1	0	0	0	0	0	0	0
10h	Timer_value	0	0	0	0	0	0	0	0
11h	Timer_mode	0	0	0	1	1	0	0	0

The PCA85074A resets to:

**Time**

00:00:00

**Date**

20000101

**Weekday**

Saturday

**7.2.2 Register Control\_2**

[Table 8](#) describes the bit configuration of the Control\_2 register.

Table 8. Control\_2 - control and status register 2 (address 01h) bit description

Bit	Symbol	Value	Description	Reference
7	AIE		<b>Alarm interrupt</b>	<a href="#">Section 7.2.2.1</a> <a href="#">Section 7.5.6</a>
		0 <sup>[1]</sup>	Disabled	
		1	Enabled	
6	AF		<b>Alarm flag</b>	<a href="#">Section 7.2.2.1</a> <a href="#">Section 7.5.6</a>
		0 <sup>[1]</sup>	Read: alarm flag inactive	
			Write: alarm flag is cleared	
		1	Read: alarm flag active	
Write: alarm flag remains unchanged				
5	MI		<b>Minute interrupt</b>	<a href="#">Section 7.2.2.2</a> <a href="#">Section 7.2.2.3</a>
		0 <sup>[1]</sup>	Disabled	
		1	Enabled	
4	HMI		<b>Half minute interrupt</b>	<a href="#">Section 7.2.2.2</a> <a href="#">Section 7.2.2.3</a>
		0 <sup>[1]</sup>	Disabled	
		1	Enabled	

Table 8. Control\_2 - control and status register 2 (address 01h) bit description...continued

Bit	Symbol	Value	Description	Reference
3	TF		<b>Timer flag</b>	<a href="#">Section 7.2.2.1</a>
		0 <sup>[1]</sup>	No timer interrupt generated	<a href="#">Section 7.2.2.3</a>
		1	Flag set when timer interrupt generated	<a href="#">Section 7.6.3</a>
2 to 0	COF[2:0]	See <a href="#">Table 10</a>	<b>CLKOUT control</b>	<a href="#">Section 7.2.2.4</a>

[1] Default value.

7.2.2.1 Alarm interrupt

Figure 7 shows the interrupt scheme for PCA85074A.

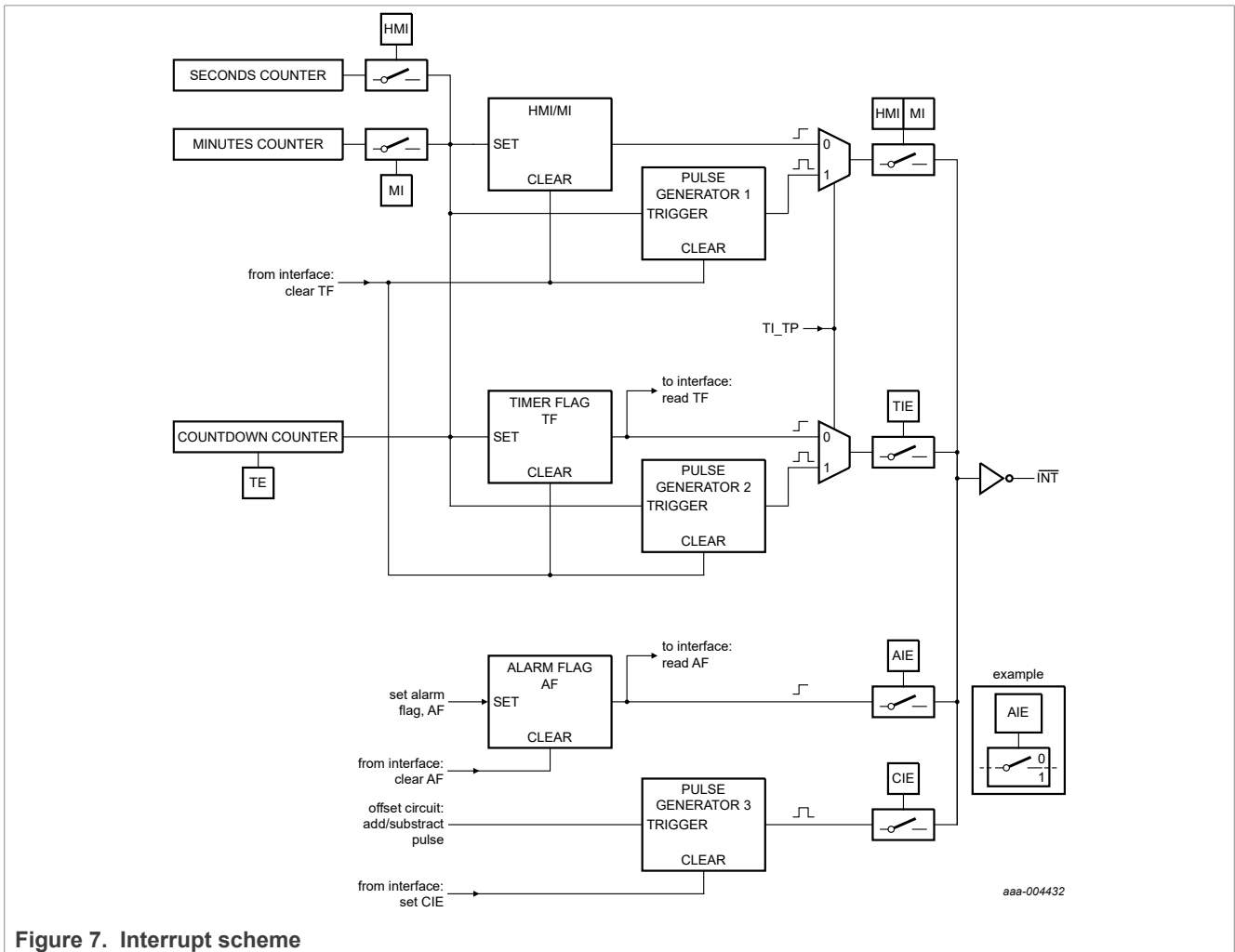

Figure 7. Interrupt scheme

AIE

This bit activates or deactivates the generation of an interrupt when AF is asserted, respectively.

**AF**

When an alarm occurs, AF is set to logic 1. This bit maintains its value until overwritten by a command. To prevent one flag being overwritten while clearing another, a logic AND is performed during a write access.

**7.2.2.2 MI and HMI: minute and a half minute interrupt**

The minute interrupt (bit MI) and half minute interrupt (bit HMI) are pre-defined timers for generating interrupt pulses on pin  $\overline{\text{INT}}$ ; see [Figure 8](#). The timers are running in sync with the seconds counter (see [Table 18](#)).

The minute and half minute interrupts must only be used when the frequency offset is set to normal mode (MODE = 0), see [Section 7.2.3](#). In normal mode, the interrupt pulses on pin  $\overline{\text{INT}}$  are  $\frac{1}{64}$  s wide.

When starting MI, the first interrupt will be generated after 1 second to 59 seconds. When starting HMI, the first interrupt will be generated after 1 second to 29 seconds. Subsequent periods do not have such a delay. The timers can be enabled independently from one another. However, a minute interrupt enabled on top of a half minute interrupt is not distinguishable.

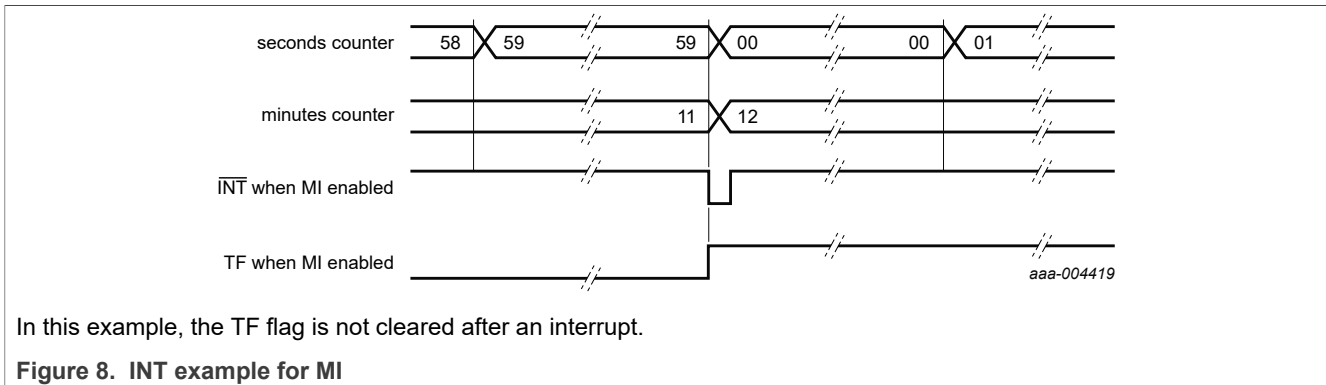

In this example, the TF flag is not cleared after an interrupt.

**Figure 8. INT example for MI**

**Table 9. Effect of bits MI and HMI on  $\overline{\text{INT}}$  generation**

Minute interrupt (bit MI)	Half minute interrupt (bit HMI)	Result
0	0	No interrupt generated
1	0	An interrupt every minute
0	1	An interrupt every 30 s
1	1	An interrupt every 30 s

The duration of the timer is affected by the register Offset (see [Section 7.2.3](#)). Only when OFFSET[6:0] has the value 00h the periods are consistent.

**7.2.2.3 TF: timer flag**

The timer flag (bit TF) is set logic 1 on the first trigger of MI, HMI, or the countdown timer. The purpose of the flag is to allow the controlling system to interrogate what caused the interrupt: timer or alarm. The flag can be read and cleared by command.

The status of the timer flag TF can affect the  $\overline{\text{INT}}$  pulse generation depending on the setting of TI\_TP (see [Section 7.6.2](#)):

- When TI\_TP is set logic 1
  - an  $\overline{\text{INT}}$  pulse is generated independent of the status of the timer flag TF
  - TF stays set until it is cleared
  - TF does not affect  $\overline{\text{INT}}$

- the countdown timer runs in a repetitive loop and keeps generating timed periods
- When TI\_TP is set logic 0
  - the  $\overline{\text{INT}}$  generation follows the TF flag
  - TF stays set until it is cleared
  - If TF is not cleared before the next coming interrupt, no  $\overline{\text{INT}}$  is generated
  - the countdown timer stops after the first countdown

**7.2.2.4 COF[2:0]: Clock output frequency**

A programmable square wave is available at pin CLKOUT. Operation is controlled by the COF[2:0] bits in the register Control\_2. Frequencies of 32.768 kHz (default) down to 1 Hz can be generated for use as a system clock, microcontroller clock, input to a charge pump, or for calibration of the oscillator.

Pin CLKOUT is a push-pull output and enabled at power on. CLKOUT can be disabled by setting COF[2:0] to 111. When disabled, the CLKOUT is LOW.

The duty cycle of the selected clock is not controlled. However, due to the nature of the clock generation, all clock frequencies except 32.768 kHz have a duty cycle of 50 : 50.

The stop bit function can also affect the CLKOUT signal, depending on the selected frequency. When the stop bit is set to logic 1, the CLKOUT pin generates a continuous LOW for those frequencies that can be stopped. For more details of the stop bit function, see [Section 7.2.1.1](#).

**Table 10. CLKOUT frequency selection**

COF[2:0]	CLKOUT frequency (Hz)	Typical duty cycle <sup>[1]</sup>	Effect of stop bit
000 <sup>[2]</sup>	32 768	60 : 40 to 40 : 60	No effect
001	16 384	50 : 50	No effect
010	8 192	50 : 50	No effect
011	4 096	50 : 50	CLKOUT = LOW
100	2 048	50 : 50	CLKOUT = LOW
101	1 024	50 : 50	CLKOUT = LOW
110	1 <sup>[3]</sup>	50 : 50	CLKOUT = LOW
111	CLKOUT = LOW	-	-

[1] Duty cycle definition: % HIGH-level time: % LOW-level time.

[2] Default value.

[3] 1 Hz clock pulses are affected by offset correction pulses.

**7.2.3 Register Offset**

The PCA85074A incorporates an offset register (address 02h) which can be used to implement several functions, such as:

- Accuracy tuning
- Aging adjustment
- Temperature compensation

**Table 11. Offset - offset register (address 02h) bit description**

Bit	Symbol	Value	Description
7	MODE		<b>Offset mode</b>
		0 <sup>[1]</sup>	Normal mode: offset is made once every two hours

Table 11. Offset - offset register (address 02h) bit description...continued

Bit	Symbol	Value	Description
		1	Course mode: offset is made every 4 minutes
6 to 0	OFFSET[6:0]	See Table 12	<b>Offset value</b>

[1] Default value.

For MODE = 0, each LSB introduces an offset of 4.34 ppm. For MODE = 1, each LSB introduces an offset of 4.069 ppm. The offset value is coded in two's complement giving a range of +63 LSB to -64 LSB.

Table 12. Offset values

OFFSET[6:0]	Offset value in decimal	Offset value in ppm	
		Normal mode MODE = 0	Fast mode MODE = 1
011 1111	+63	+273.420	+256.347
011 1110	+62	+269.080	+252.278
:	:	:	:
000 0010	+2	+8.680	+8.138
000 0001	+1	+4.340	+4.069
000 0000 <sup>[1]</sup>	0	0 <sup>[1]</sup>	0 <sup>[1]</sup>
111 1111	-1	-4.340	-4.069
111 1110	-2	-8.680	-8.138
:	:	:	:
100 0001	-63	-273.420	-256.347
100 0000	-64	-277.760	-260.416

[1] Default value.

The correction is made by adding or subtracting clock correction pulses, thereby changing the period of a single second but not by changing the oscillator frequency.

It is possible to monitor when correction pulses are applied. To enable correction interrupt generation, bit CIE (register Control\_1) has to be set to logic 1. At every correction cycle, a pulse is generated on pin  $\overline{\text{INT}}$ . The pulse width depends on the correction mode. If multiple correction pulses are applied, an interrupt pulse is generated for each correction pulse applied.

### 7.2.3.1 Correction when MODE = 0

The correction is triggered once every two hours and then correction pulses are applied once per minute until the programmed correction values have been implemented.

Table 13. Correction pulses for MODE = 0

Correction value	Update every n <sup>th</sup> hour	Minute	Correction pulses on $\overline{\text{INT}}$ per minute <sup>[1]</sup>
+1 or -1	2	00	1
+2 or -2	2	00 and 01	1
+3 or -3	2	00, 01, and 02	1

Table 13. Correction pulses for MODE = 0...continued

Correction value	Update every n <sup>th</sup> hour	Minute	Correction pulses on INT per minute <sup>[1]</sup>
:	:	:	:
+59 or -59	2	00 to 58	1
+60 or -60	2	00 to 59	1
+61 or -61	2	00 to 59	1
	2nd and next hour	00	1
+62 or -62	2	00 to 59	1
	2nd and next hour	00 and 01	1
+63 or -63	02	00 to 59	1
	2nd and next hour	00, 01, and 02	1
-64	02	00 to 59	1
	2nd and next hour	00, 01, 02, and 03	1

[1] The correction pulses on pin INT are 1/64 s wide.

In MODE = 0, any timer or clock output using a frequency below 64 Hz is affected by the clock correction (see Table 14).

Table 14. Effect of correction pulses on frequencies for MODE = 0

Frequency (Hz)	Effect of correction
<b>CLKOUT</b>	
32 768	No effect
16 384	No effect
8 192	No effect
4 096	No effect
2 048	No effect
1 024	No effect
1	Affected
<b>Timer source clock</b>	
4 096	No effect
64	No effect
1	Affected
1/60	Affected

### 7.2.3.2 Correction when MODE = 1

The correction is triggered once every four minutes and then correction pulses are applied once per second up to a maximum of 60 pulses. When correction values greater than 60 pulses are used, additional correction pulses are made in the 59<sup>th</sup> second.

Clock correction is made more frequently in MODE = 1; however, this can result in higher power consumption.

Table 15. Correction pulses for MODE = 1

Correction value	Update every n <sup>th</sup> minute	Second	Correction pulses on INT per second <sup>[1]</sup>
+1 or -1	4	00	1
+2 or -2	4	00 and 01	1
+3 or -3	4	00, 01, and 02	1
:	:	:	:
+59 or -59	4	00 to 58	1
+60 or -60	4	00 to 59	1
+61 or -61	4	00 to 58	1
	4	59	2
+62 or -62	4	00 to 58	1
	4	59	3
+63 or -63	4	00 to 58	1
	4	59	4
-64	4	00 to 58	1
	4	59	5

[1] The correction pulses on pin INT are 1/1024 s wide. For multiple pulses, they are repeated at an interval of 1/612 s.

In MODE = 1, any timer source clock using a frequency below 1.024 kHz is also affected by the clock correction (see Table 16).

Table 16. Effect of correction pulses on frequencies for MODE = 1

Frequency (Hz)	Effect of correction
<b>CLKOUT</b>	
32 768	No effect
16 384	No effect
8 192	No effect
4 096	No effect
2 048	No effect
1 024	No effect
1	Affected
<b>Timer source clock</b>	
4 096	No effect
64	Affected
1	Affected
1/60	Affected

### 7.2.3.3 Offset calibration workflow

The calibration offset has to be calculated based on the time. Figure 9 shows the workflow how the offset register values can be calculated:

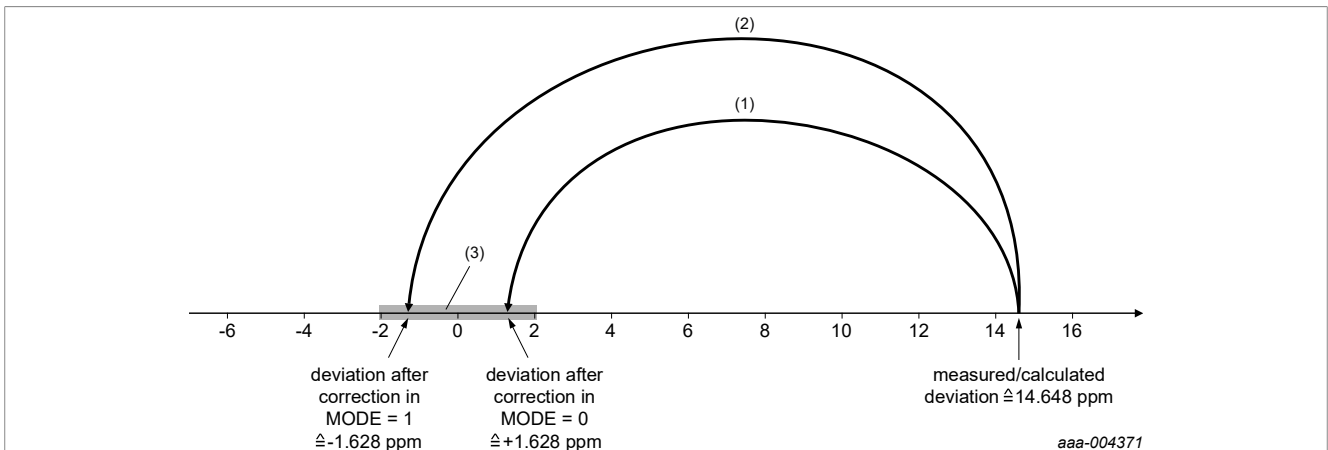
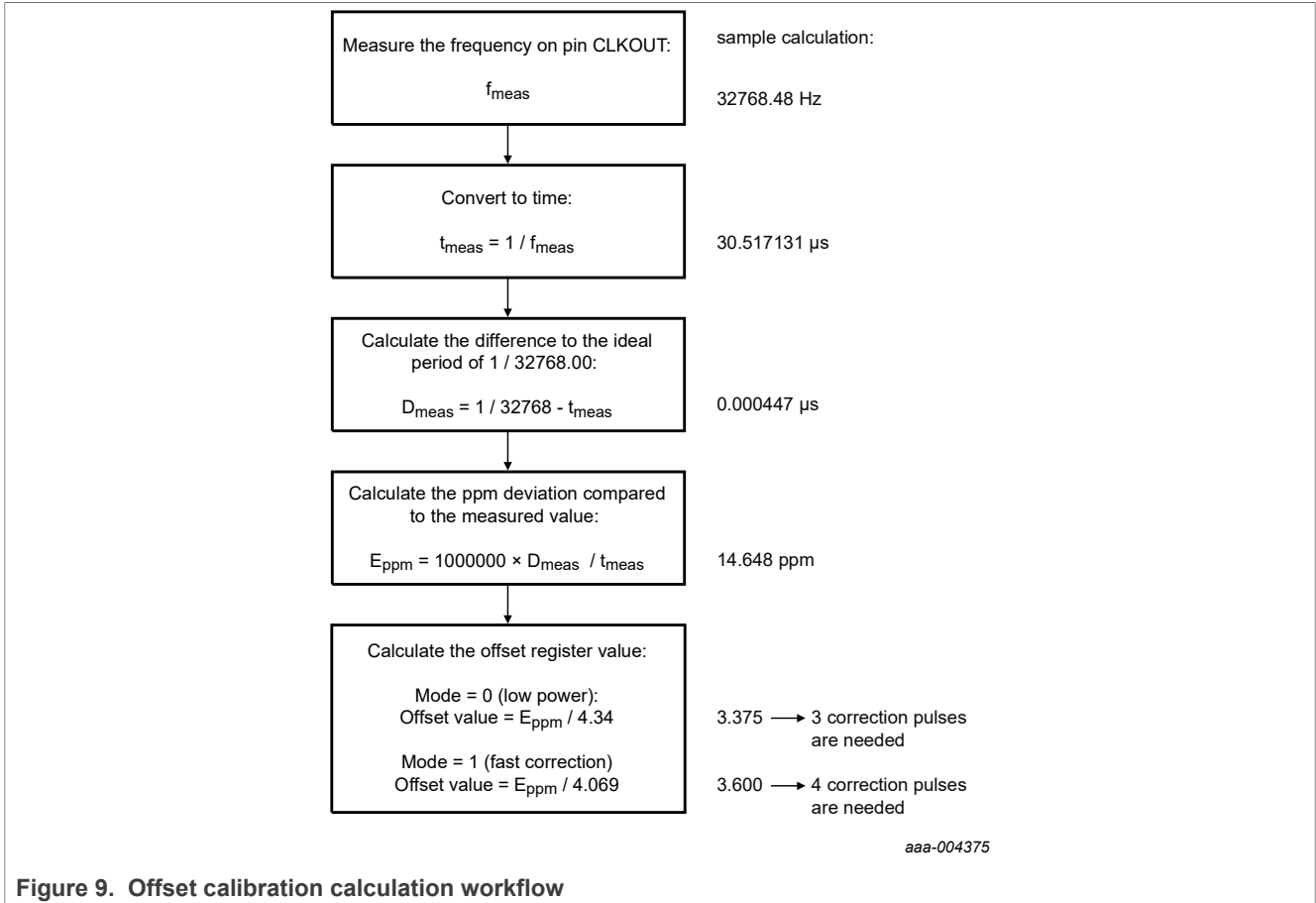

With the offset calibration an accuracy of ±2 ppm (0.5 × offset per LSB) can be reached (see Table 12).

±1 ppm corresponds to a time deviation of 0.0864 seconds per day.

1. 3 correction pulses in MODE = 0 correspond to -13.02 ppm.
2. 4 correction pulses in MODE = 1 correspond to -16.276 ppm.
3. Reachable accuracy zone.

**Figure 10. Result of offset calibration**

### 7.2.4 Register RAM\_byte

The PCA85074A provides a free RAM byte, which can be used for any purpose, for example, the status byte of the system.

Table 17. RAM\_byte - 8-bit RAM register (address 03h) bit description

Bit	Symbol	Value	Description
7 to 0	B[7:0]	0000 0000 <sup>[1]</sup> to 1111 1111	<b>RAM content</b>

[1] Default value.

### 7.3 Time and date registers

Most of the registers are coded in the BCD format to simplify application use.

#### 7.3.1 Register Seconds

[Table 18](#) and [Table 19](#) describe the bit configuration of the Seconds register and the representation of seconds coded in BCD format, respectively.

Table 18. Seconds - seconds register (address 04h) bit description

Bit	Symbol	Value	Place value	Description
7	OS			<b>Oscillator stop</b>
		0	-	Clock integrity is guaranteed
		1 <sup>[1]</sup>	-	Clock integrity is not guaranteed; the oscillator has stopped or has been interrupted
6 to 4	SECONDS	0 <sup>[1]</sup> to 5	Ten's place	<b>Actual seconds</b> coded in BCD format, see <a href="#">Table 19</a>
3 to 0		0 <sup>[1]</sup> to 9	Unit place	

[1] Default value.

Table 19. Seconds coded in BCD format

Seconds value in decimal	Upper-digit (ten's place)			Digit (unit place)			
	Bit 6	Bit 5	Bit 4	Bit 3	Bit 2	Bit 1	Bit 0
00 <sup>[1]</sup>	0	0	0	0	0	0	0
01	0	0	0	0	0	0	1
02	0	0	0	0	0	1	0
:	:	:	:	:	:	:	:
09	0	0	0	1	0	0	1
10	0	0	1	0	0	0	0
:	:	:	:	:	:	:	:
58	1	0	1	1	0	0	0
59	1	0	1	1	0	0	1

[1] Default value.

7.3.1.1 OS: Oscillator stop

When the oscillator of the PCA85074A is stopped, the OS flag is set. The oscillator can be stopped, for example, by connecting one of the oscillator pins OSC1 or OSC0 to the ground. The oscillator is considered to be stopped during the time between power on and stable crystal resonance. This time can be in the range of 200 ms to 2 s depending on crystal type, temperature, and supply voltage.

The flag remains set until cleared by command (see Figure 11). If the flag cannot be cleared, then the oscillator is not running. This method can be used to monitor the oscillator and to determine if the supply voltage has reduced to the point where oscillation fails.

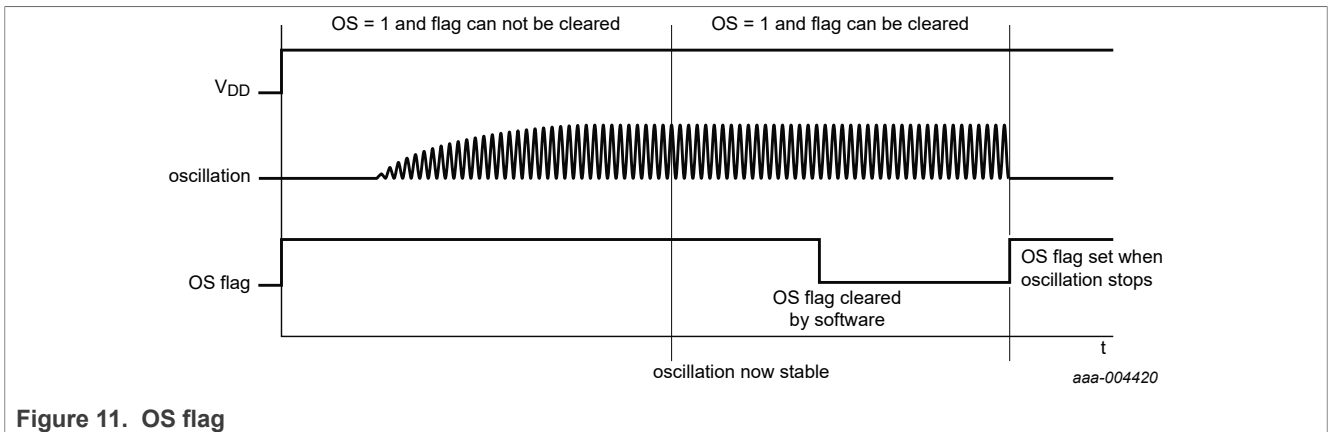

Figure 11. OS flag

7.3.2 Register Minutes

Table 20 describes the bit configuration of the Minutes register.

Table 20. Minutes - minutes register (address 05h) bit description

Bit	Symbol	Value	Place value	Description
7	-	0	-	Unused
6 to 4	MINUTES	0 <sup>[1]</sup> to 5	Tens place	<b>Actual minutes</b> coded in BCD format
3 to 0		0 <sup>[1]</sup> to 9	Unit place	

[1] Default value.

7.3.3 Register Hours

Table 21 describes the bit configuration of the Hours register.

Table 21. Hours - hours register (address 06h) bit description

Bit	Symbol	Value	Place value	Description
7 to 6	-	00	-	Unused
<b>12-hour mode<sup>[1]</sup></b>				
5	AMPM			<b>AM/PM indicator</b>
		0 <sup>[2]</sup>	-	AM
		1	-	PM
4	HOURS	0 <sup>[2]</sup> to 1	Tens place	<b>Actual hours in 12-hour mode</b> coded in BCD format
3 to 0		0 <sup>[2]</sup> to 9	Unit place	

Table 21. Hours - hours register (address 06h) bit description...continued

Bit	Symbol	Value	Place value	Description
<b>24-hour mode</b> <sup>[1]</sup>				
5 to 4	HOURS	0 <sup>[2]</sup> to 2	Tens place	<b>Actual hours in 24-hour mode</b> coded in BCD format
3 to 0		0 <sup>[2]</sup> to 9	Unit place	

[1] Hour mode is set by the 12\_24 bit in register Control\_1.

[2] Default value.

### 7.3.4 Register Days

Table 22 describes the bit configuration of the Days register.

Table 22. Days - days register (address 07h) bit description

Bit	Symbol	Value	Place value	Description
7 to 6	-	00	-	Unused
5 to 4	DAYS <sup>[1]</sup>	0 <sup>[2]</sup> to 3	Tens place	<b>Actual day</b> coded in BCD format
3 to 0		0 <sup>[3]</sup> to 9	Unit place	

[1] If the year counter contains a value, which is exactly divisible by 4 (including the year 00), the PCA85074A compensates for leap years by adding a 29th day to February.

[2] Default value.

[3] The default value is 1.

### 7.3.5 Register Weekdays

Table 23 describes the bit configuration of the Weekdays register and Table 24 shows the weekday assignments stored in the Weekdays register.

Table 23. Weekdays - weekdays register (address 08h) bit description

Bit	Symbol	Value	Description
7 to 3	-	0000 0	Unused
2 to 0	WEEKDAYS	0 to 6	<b>Actual weekday</b> values, see Table 24

Table 24. Weekday assignments

Day <sup>[1]</sup>	Bit		
	2	1	0
Sunday	0	0	0
Monday	0	0	1
Tuesday	0	1	0
Wednesday	0	1	1
Thursday	1	0	0
Friday	1	0	1
Saturday <sup>[2]</sup>	1	1	0

[1] The definition can be reassigned by the user.

[2] Default value.

### 7.3.6 Register Months

[Table 25](#) describes the bit configuration of the Months register and [Table 25](#) shows the month assignments stored in the Months register.

**Table 25. Months - months register (address 09h) bit description**

Bit	Symbol	Value	Place value	Description
7 to 5	-	000	-	Unused
4	MONTHS	0 to 1	Tens place	<b>Actual month</b> coded in BCD format, see <a href="#">Table 26</a> .
3 to 0		0 to 9	Unit place	

**Table 26. Month assignments in BCD format**

Month	Upper-digit (tens place)	Digit (unit place)			
	Bit 4	Bit 3	Bit 2	Bit 1	Bit 0
January <sup>[1]</sup>	0	0	0	0	1
February	0	0	0	1	0
March	0	0	0	1	1
April	0	0	1	0	0
May	0	0	1	0	1
June	0	0	1	1	0
July	0	0	1	1	1
August	0	1	0	0	0
September	0	1	0	0	1
October	1	0	0	0	0
November	1	0	0	0	1
December	1	0	0	1	0

[1] Default value.

### 7.3.7 Register Years

[Table 27](#) describes the bit configuration of the Years register.

**Table 27. Years - years register (0Ah) bit description**

Bit	Symbol	Value	Place value	Description
7 to 4	YEARS	0 <sup>[1]</sup> to 9	Tens place	<b>Actual year</b> coded in BCD format
3 to 0		0 <sup>[1]</sup> to 9	Unit place	

[1] Default value.

## 7.4 Setting and reading the time

[Figure 12](#) shows the data flow and data dependencies starting from the 1 Hz clock tick.

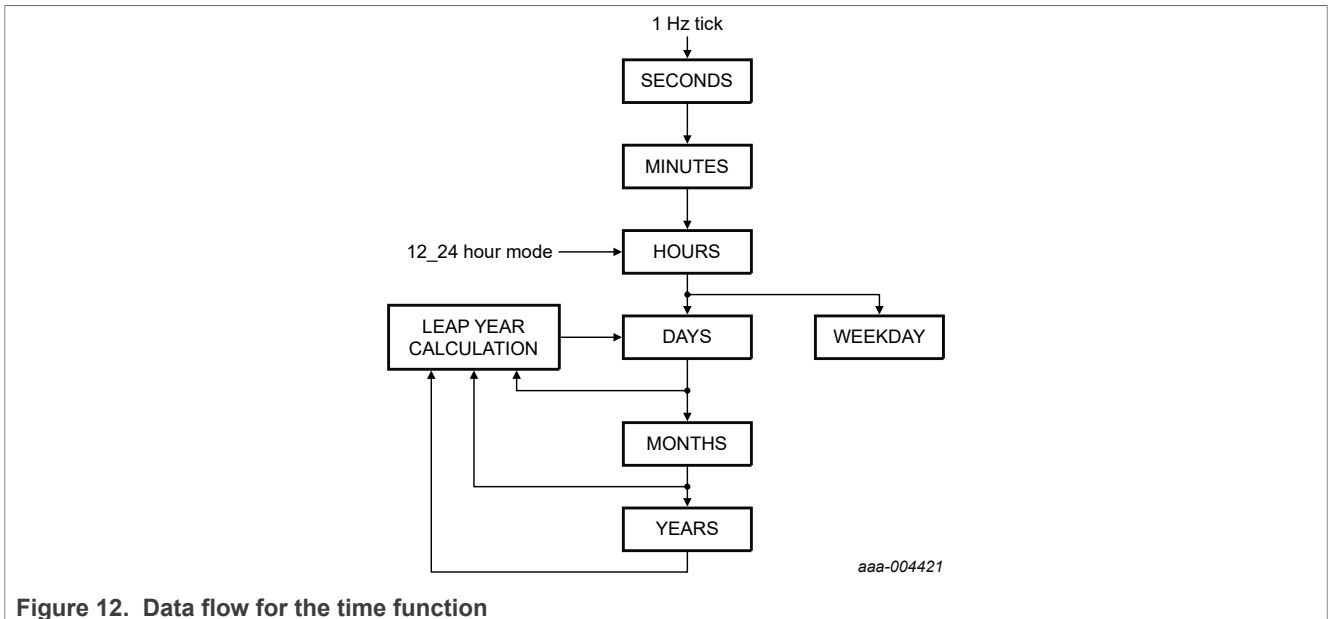

Figure 12. Data flow for the time function

During read/write operations, the time counting circuits (memory locations 04h through 0Ah) are blocked.

The blocking prevents

- Faulty reading of the clock and calendar during a carry condition
- Incrementing the time registers during the read cycle

After this read/write access is completed, the time circuit is released again and any pending request to increment the time counters that occurred during the read/write access is serviced. A maximum of one request can be stored; therefore, all accesses must be completed within 1 second (see Figure 13).

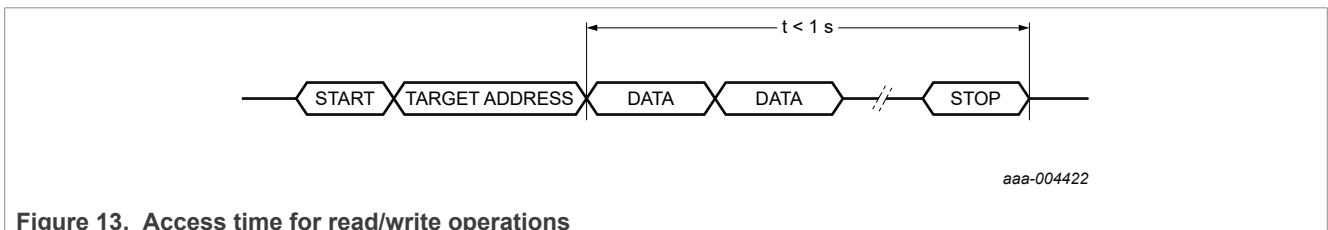

Figure 13. Access time for read/write operations

Due to this method, it is important to make a read or write access in one go, that is, setting or reading seconds through to years must be made in one single access. Failing to comply with this method could result in the time becoming corrupted.

As an example, if the time (seconds through to hours) is set in one access and then in a second access the date is set, it is possible that the time increments between the two accesses. A similar problem exists when reading. A roll-over can occur between reads, therefore giving the minutes from one moment and the hours from the next.

Recommended method for reading the time:

1. Send a START condition and the target address (see Table 38) for write (A2h)
2. Set the address pointer to 4 (Seconds) by sending 04h
3. Send a RESTART condition or STOP followed by START
4. Send the target address for read (A3h)
5. Read Seconds
6. Read Minutes

7. Read Hours
8. Read Days
9. Read Weekdays
10. Read Months
11. Read Years
12. Send a STOP condition

## 7.5 Alarm registers

This section covers the various alarm function and its registers.

### 7.5.1 Register Second\_alarm

[Table 28](#) describes the bit configuration of the Second\_alarm register.

**Table 28. Second\_alarm - second alarm register (address 0Bh) bit description**

Bit	Symbol	Value	Place value	Description
7	AEN_S			<b>Second alarm</b>
		0	-	Enabled
		1 <sup>[1]</sup>	-	Disabled
6 to 4	SECOND_ALARM	0 <sup>[1]</sup> to 5	Tens place	<b>Second alarm information</b> coded in BCD format
3 to 0		0 <sup>[1]</sup> to 9	Unit place	

[1] Default value.

### 7.5.2 Register Minute\_alarm

[Table 29](#) describes the bit configuration of the Minute\_alarm register.

**Table 29. Minute\_alarm - minute alarm register (address 0Ch) bit description**

Bit	Symbol	Value	Place value	Description
7	AEN_M			<b>Minute alarm</b>
		0	-	Enabled
		1 <sup>[1]</sup>	-	Disabled
6 to 4	MINUTE_ALARM	0 <sup>[1]</sup> to 5	Tens place	<b>Minute alarm information</b> coded in BCD format
3 to 0		0 <sup>[1]</sup> to 9	Unit place	

[1] Default value.

### 7.5.3 Register Hour\_alarm

[Table 30](#) describes the bit configuration of the Hour\_alarm register.

**Table 30. Hour\_alarm - hour alarm register (address 0Dh) bit description**

Bit	Symbol	Value	Place value	Description
7	AEN_H			<b>Hour alarm</b>
		0	-	Enabled
		1 <sup>[1]</sup>	-	Disabled

Table 30. Hour\_alarm - hour alarm register (address 0Dh) bit description...continued

Bit	Symbol	Value	Place value	Description
6	-	0	-	Unused
<b>12-hour mode</b> <sup>[2]</sup>				
5	AMPM			<b>AM/PM indicator</b>
		0 <sup>[1]</sup>	-	AM
		1	-	PM
4	HOUR_ALARM	0 <sup>[1]</sup> to 1	Tens place	<b>Hour alarm information in 12-hour mode</b> coded in BCD format
3 to 0		0 <sup>[1]</sup> to 9	Unit place	
<b>24-hour mode</b> <sup>[2]</sup>				
5 to 4	HOUR_ALARM	0 <sup>[1]</sup> to 2	Tens place	<b>Hour alarm information in 24-hour mode</b> coded in BCD format
3 to 0		0 <sup>[1]</sup> to 9	Unit place	

[1] Default value.

[2] Hour mode is set by the 12\_24 bit in register Control\_1.

### 7.5.4 Register Day\_alarm

[Table 31](#) describes the bit configuration of the Day\_alarm register.

Table 31. Day\_alarm - day alarm register (address 0Eh) bit description

Bit	Symbol	Value	Place value	Description
7	AEN_D			<b>Day alarm</b>
		0	-	Enabled
		1 <sup>[1]</sup>	-	Disabled
6	-	0	-	Unused
5 to 4	DAY_ALARM	0 <sup>[1]</sup> to 3	Tens place	<b>Day alarm information</b> coded in BCD format
3 to 0		0 <sup>[1]</sup> to 9	Unit place	

[1] Default value.

### 7.5.5 Register Weekday\_alarm

[Table 32](#) describes the bit configuration of the Weekday\_alarm register.

Table 32. Weekday\_alarm - weekday alarm register (address 0Fh) bit description

Bit	Symbol	Value	Description
7	AEN_W		<b>Weekday alarm</b>
		0	Enabled
		1 <sup>[1]</sup>	Disabled
6 to 3	-	0	Unused
2 to 0	WEEKDAY_ALARM	0 <sup>[1]</sup> to 6	<b>Weekday alarm information</b> coded in BCD format

[1] Default value.

7.5.6 Alarm function

By clearing the alarm enable bit (AEN\_x) of one or more of the alarm registers, the corresponding alarm condition(s) are active. When an alarm occurs, AF is set to logic 1. The asserted AF can be used to generate an interrupt ( $\overline{INT}$ ). The AF is cleared by command.

The registers at addresses 0Bh through 0Fh contain alarm information. When one or more of these registers is loaded with second, minute, hour, day or weekday, and its corresponding AEN\_x is logic 0, then that information is compared with the current second, minute, hour, day, and weekday. When all enabled comparisons first match, the alarm flag (AF in register Control\_2) is set to logic 1.

The generation of interrupts from the alarm function is controlled via bit AIE. If bit AIE is enabled, the  $\overline{INT}$  pin follows the condition of bit AF. AF remains set until cleared by command. Once AF is cleared, it is only set again when the time increments to match the alarm condition once more. Alarm registers, which have their AEN\_x bit at logic 1 are ignored.

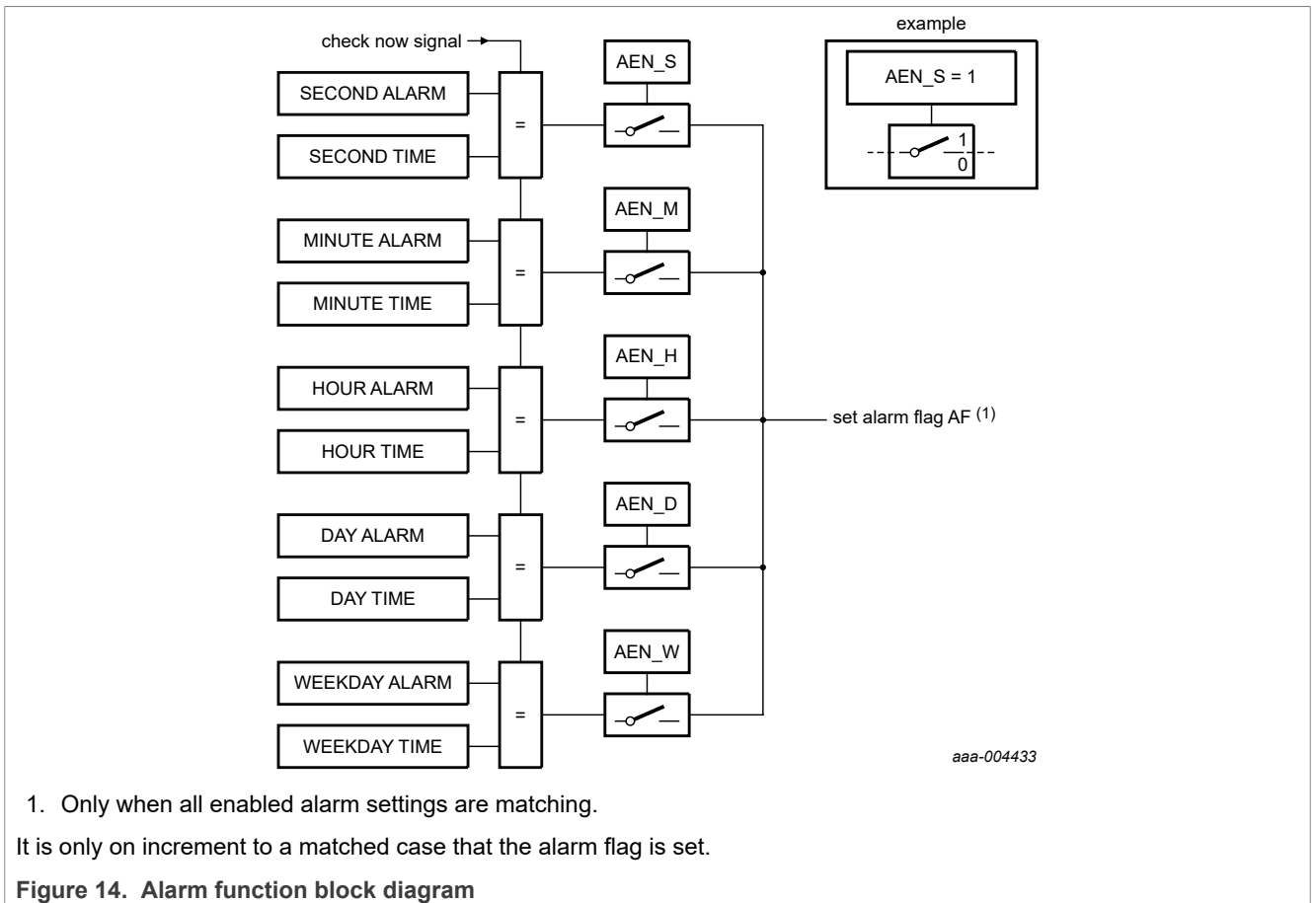

- 1. Only when all enabled alarm settings are matching. It is only on increment to a matched case that the alarm flag is set.

Figure 14. Alarm function block diagram

7.6 Timer registers

The register Timer\_mode at address 11h controls the 8-bit countdown timer at address 10h.

### 7.6.1 Register Timer\_value

[Table 33](#) describes the bit configuration of the Timer\_value register.

**Table 33. Timer\_value - timer value register (address 10h) bit description**

Bit	Symbol	Value	Description
7 to 0	T[7:0]	0h <sup>[1]</sup> to FFh	<b>Countdown timer value</b> <sup>[2]</sup>

[1] Default value.

[2] Countdown period in seconds:  $CountdownPeriod = \frac{T}{SourceClockFrequency}$  where T is the countdown value.

### 7.6.2 Register Timer\_mode

[Table 34](#) describes the bit configuration of the Timer\_mode register.

**Table 34. Timer\_mode - timer control register (address 11h) bit description**

Bit	Symbol	Value	Description
7 to 5	-	000	Unused
4 to 3	TCF[1:0]		<b>Timer clock frequency</b>
		00	4.096 kHz timer source clock
		01	64 Hz timer source clock
		10	1 Hz timer source clock
		11 <sup>[1]</sup>	$\frac{1}{60}$ Hz timer source clock
2	TE		<b>Timer enable</b>
		0 <sup>[1]</sup>	Timer is disabled
		1	Timer is enabled
1	TIE		<b>Timer interrupt enable</b>
		0 <sup>[1]</sup>	No interrupt generated from timer
		1	Interrupt generated from timer
0	TI_TP <sup>[2]</sup>		<b>Timer interrupt mode</b>
		0 <sup>[1]</sup>	Interrupt follows timer flag
		1	Interrupt generates a pulse

[1] Default value.

[2] How the setting of TI\_TP and the timer flag TF can affect the INT pulse generation is explained in [Section 7.2.2.3](#).

### 7.6.3 Timer functions

The timer has four selectable source clocks allowing for countdown periods in the range from 244 μs to 4 hours 15 min. For periods longer than 4 hours, the alarm function can be used.

Table 35. Timer clock frequency and timer durations

TCF[1:0]	Timer source clock frequency <sup>[1]</sup>	Delay	
		Minimum timer duration T = 1	Maximum timer duration T = 255
00	4.096 kHz	244 μs	62.256 ms
01	64 Hz	15.625 ms	3.984 s
10	1 Hz <sup>[2]</sup>	1 s	255 s
11	1/60 Hz <sup>[2]</sup>	60 s	4 hours 15 min

[1] When not in use, TCF[1:0] must be set to 1/60 Hz for Power-saving.  
 [2] Time periods can be affected by correction pulses.

**Remark:** Note that all timings, which are generated from the 32.768 kHz oscillator are based on the assumption that there is 0 ppm deviation. Deviation in oscillator frequency results in deviation in timings. This is not applicable to interface timing.

The timer counts down from a software-loaded 8-bit binary value, T[7:0], in register Timer\_value. Loading the counter with 0 stops the timer. Values from 1 to 255 are valid.

When the counter decrements from 1, the TF bit in Control\_2 is set. The counter then reloads automatically. It starts the next timer period.

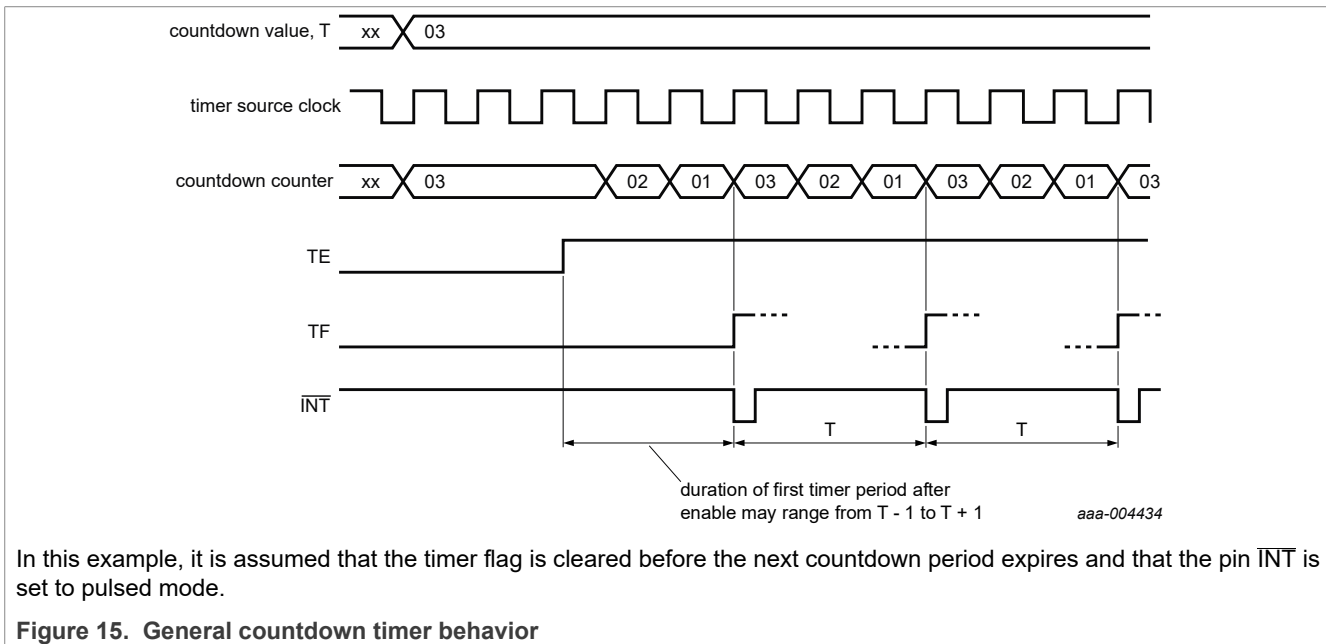

Figure 15. General countdown timer behavior

If a new value of T is written before the end of the current timer period, then this value takes immediate effect. NXP does not recommend changing T without first disabling the counter by setting bit TE logic 0. The update of T is asynchronous to the timer clock. Therefore, changing it without setting bit TE logic 0 may result in a corrupted value loaded into the countdown counter. This results in an undetermined countdown period for the first period. The countdown value T will, however, be correctly stored and correctly loaded on subsequent timer periods.

When the TIE flag is set, an interrupt signal on INT is generated if this mode is enabled. See Section 7.2.2 for details on how the interrupt can be controlled.

When starting the timer for the first time, the first period has an uncertainty. The uncertainty is a result of the enable instruction being generated from the interface clock, which is asynchronous from the timer source clock.

Subsequent timer periods do not have such delay. The amount of delay for the first timer period depends on the chosen source clock, see [Table 36](#).

Table 36. First period delay for timer counter value T

Timer source clock	Minimum timer period	Maximum timer period
4.096 kHz	T	T + 1
64 Hz	T	T + 1
1 Hz	$(T - 1) + \frac{1}{64\text{Hz}}$	$T + \frac{1}{64\text{Hz}}$
$\frac{1}{60}$ Hz	$(T - 1) + \frac{1}{64\text{Hz}}$	$T + \frac{1}{64\text{Hz}}$

At the end of every countdown, the timer sets the countdown timer flag (bit TF in register Control\_2). Bit TF can only be cleared by command. The asserted bit TF can be used to generate an interrupt at pin INT. The interrupt may be generated as a pulsed signal every countdown period or as a permanently active signal, which follows the condition of bit TF. Bit TI\_TP is used to control this mode selection and the interrupt output may be disabled with bit TIE, see [Table 34](#) and [Figure 15](#).

When reading the timer, the current countdown value is returned and **not** the initial value T. Since it is not possible to freeze the countdown timer counter during read back, it is recommended to read the register twice and check for consistent results.

Timer source clock frequency selection of 1 Hz and  $\frac{1}{60}$  Hz is affected by the Offset register. The duration of a program period varies according to when the offset is initiated. For example, if a 100 s timer is set using the 1 Hz clock as source, then some 100 s periods contain correction pulses and therefore be longer or shorter depending on the setting of the Offset register. See [Section 7.2.3](#) to understand the operation of the Offset register.

### 7.6.3.1 Countdown timer interrupts

The pulse generator for the countdown timer interrupt uses an internal clock and depends on the selected source clock for the countdown timer and on the countdown value T. As a consequence, the width of the interrupt pulse varies (see [Table 37](#)).

Table 37. INT operation

TF and INT become active simultaneously.

Source clock (Hz)	INT period (s)	
	T = 1 <sup>[1]</sup>	T > 1 <sup>[1]</sup>
4 096	$\frac{1}{8\ 192}$	$\frac{1}{4\ 096}$
64	$\frac{1}{128}$	$\frac{1}{64}$
1	$\frac{1}{64}$	$\frac{1}{64}$
$\frac{1}{60}$	$\frac{1}{64}$	$\frac{1}{64}$

[1] T = loaded countdown value. Timer stops when T = 0.

## 8 Characteristics of the I<sup>2</sup>C-bus interface

The I<sup>2</sup>C-bus is for bidirectional, two-line communication between different ICs or modules. The two lines are a Serial Data line (SDA) and a Serial Clock line (SCL). Both lines must be connected to a positive supply via a pullup resistor. Data transfer may be initiated only when the bus is not busy.

### 8.1 Bit transfer

One data bit is transferred during each clock pulse. The data on the SDA line must remain stable during the HIGH period of the clock pulse, as changes in the data line at this time are interpreted as a control signal (see [Figure 16](#)).

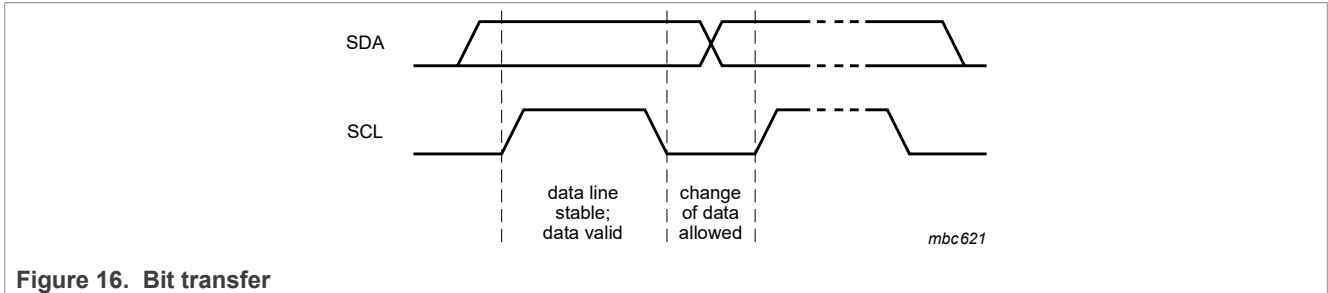

Figure 16. Bit transfer

### 8.2 START and STOP conditions

Both data and clock lines remain HIGH when the bus is not busy.

A HIGH-to-LOW transition of the data line while the clock is HIGH is defined as the START condition - S.

A LOW-to-HIGH transition of the data line while the clock is HIGH is defined as the STOP condition - P (see [Figure 17](#)).

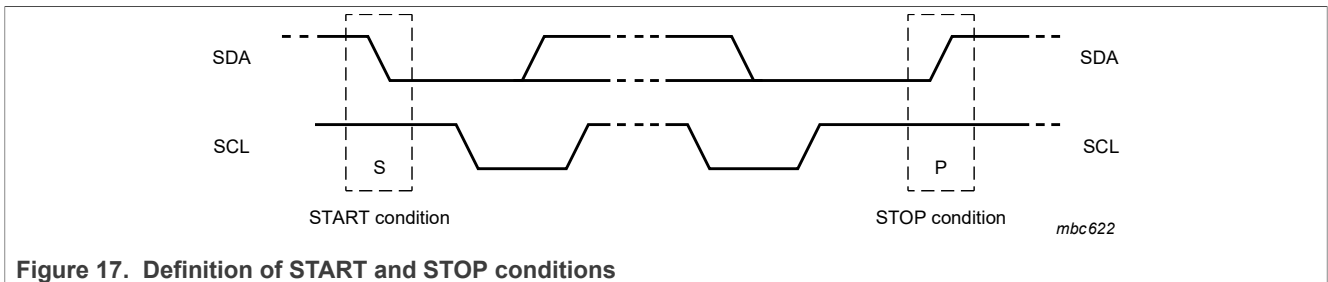

Figure 17. Definition of START and STOP conditions

### 8.3 System configuration

A device generating a message is a transmitter; a device receiving a message is a receiver. The device that controls the message is the controller; and the devices, which are controlled by the controller are the followers (see [Figure 18](#)).

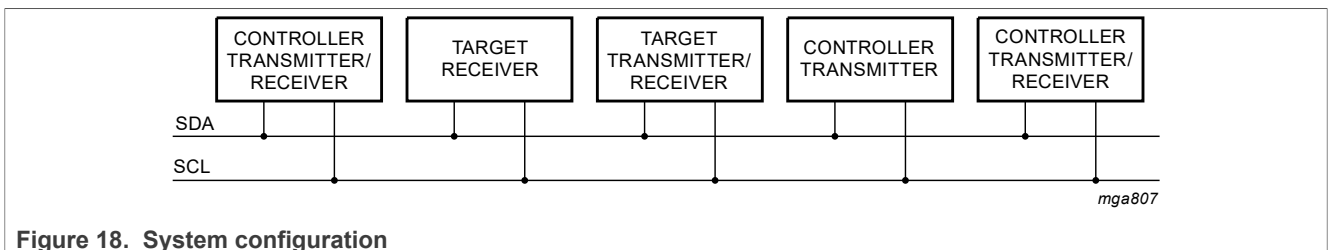

Figure 18. System configuration

### 8.4 Acknowledge

The number of data bytes transferred between the START and STOP conditions from transmitter to receiver is unlimited. Each byte of 8 bits is followed by an acknowledge cycle.

- A target receiver, which is addressed, must generate an acknowledge after the reception of each byte.

- Also, a controller receiver must generate an acknowledge after the reception of each byte that has been clocked out of the target transmitter.
- The device that acknowledges must pull down the SDA line during the acknowledge clock pulse. The SDA line must remain stable LOW during the HIGH period of the acknowledge-related clock pulse (set-up and hold times must be considered).
- A controller receiver must signal an end of data to the transmitter by not generating an acknowledge on the last byte that has been clocked out of the target. In this event, the transmitter must leave the data line HIGH to enable the controller to generate a STOP condition.

Acknowledgment on the I<sup>2</sup>C-bus is shown in [Figure 19](#).

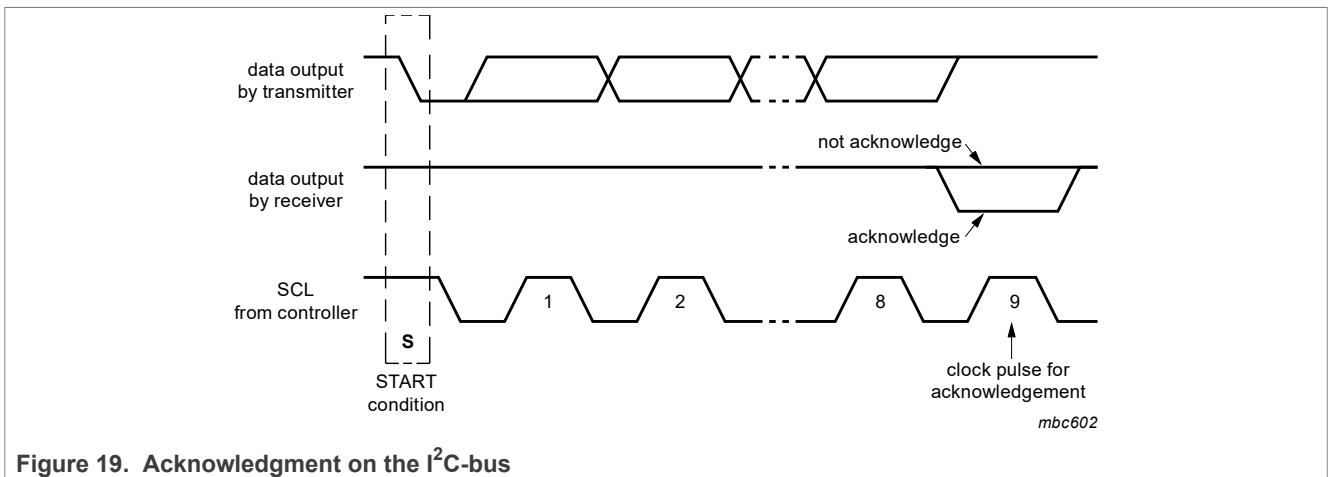

Figure 19. Acknowledgment on the I<sup>2</sup>C-bus

## 8.5 I<sup>2</sup>C-bus protocol

This section covers the following:

- Addressing
- Clock and calendar READ or WRITE cycles
- I<sup>2</sup>C-bus error recovery technique

### 8.5.1 Addressing

One I<sup>2</sup>C-bus target address (1010 001) is reserved for the PCA85074A. The entire I<sup>2</sup>C-bus target address byte is shown in [Table 38](#).

Table 38. I<sup>2</sup>C target address byte

Bit	Target address							0
	7	6	5	4	3	2	1	
	MSB							LSB
	1	0	1	0	0	0	1	R/W

After a START condition, the I<sup>2</sup>C target address has to be sent to the PCA85074A device.

The R/W bit defines the direction of the following single or multiple byte data transfers (R/W = 0 for writing, R/W = 1 for reading). For the format and the timing of the START condition (S), the STOP condition (P) and the acknowledge bit (A) refer to the I<sup>2</sup>C-bus characteristics (see [ref.\[2\]](#)). In the write mode, a data transfer is terminated by sending either the STOP condition or the START condition of the next data transfer.

8.5.2 Clock and calendar READ or WRITE cycles

The I<sup>2</sup>C-bus configuration for the different PCA85074A READ and WRITE cycles is shown in Figure 20 and Figure 21. The register address is a 5-bit value that defines which register is to be accessed next. The upper 3 bits of the register address are not used.

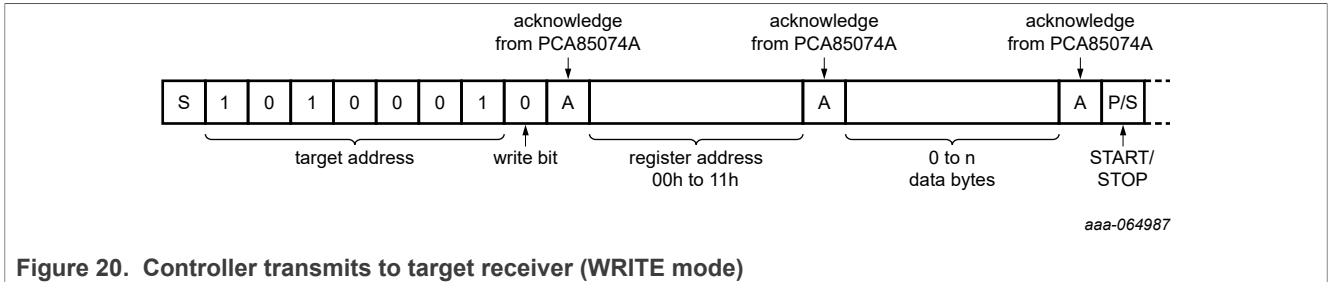
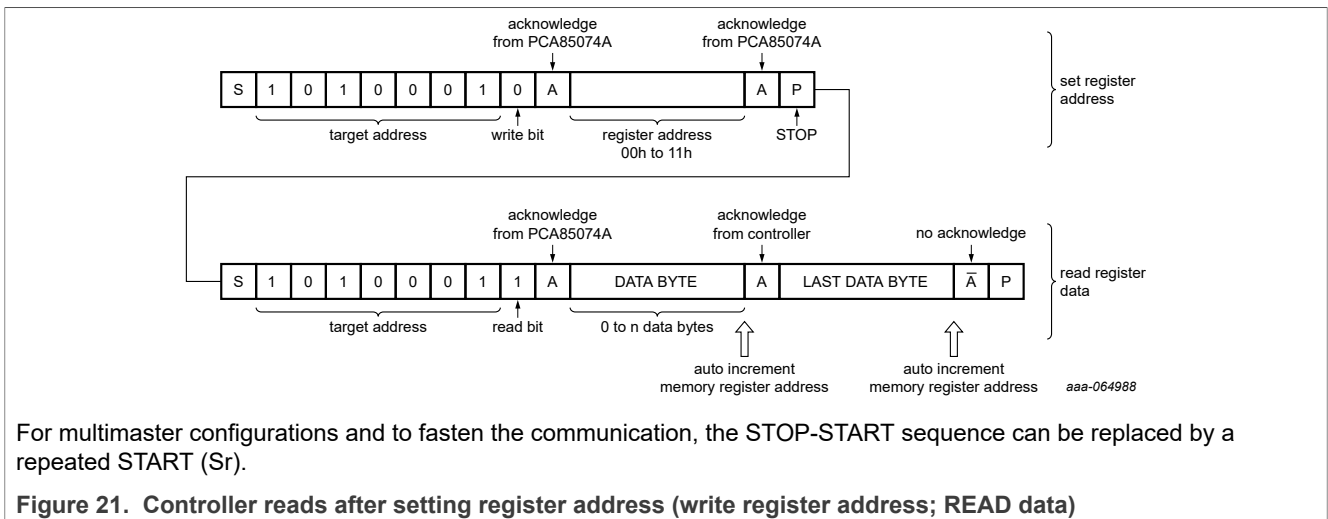

Figure 20. Controller transmits to target receiver (WRITE mode)



For multimaster configurations and to fasten the communication, the STOP-START sequence can be replaced by a repeated START (Sr).

Figure 21. Controller reads after setting register address (write register address; READ data)

8.5.3 I<sup>2</sup>C-bus error recovery technique

Target devices like the PCA85074A use a state machine to implement the I<sup>2</sup>C protocol and expect a certain sequence of events to occur to function properly. Unexpected events at the I<sup>2</sup>C controller can wreak havoc with the followers connected on the bus. However, it is possible to recover deterministically to a known bus state with careful protocol manipulation.

A deterministic method to clear this situation if SDA is stuck LOW (it effectively blocks any other I2C-bus transaction, once the controller recognizes a 'stuck bus' state), is for the controller to blindly transmit nine clocks on SCL. If the target was transmitting data or acknowledging, nine or more clocks ensure the target state machine returns to a known, idle state since the protocol calls for eight data bits and one ACK bit. It does not matter when the target state machine finishes its transmission; extra clocks are recognized as STOP conditions.

With careful design of the bus controller error recovery firmware, many I<sup>2</sup>C-bus protocol problems can be avoided.

S/W considerations: NXP recommends that customers allow for S/W reset capability to enable the bus error recovery technique. The 9-clock pulse method as described above involves a bus-controller capable of providing such a signal.

Further comments/additional information is available in [ref.\[3\]](#) and [ref.\[2\]](#).

## 9 Internal circuitry

This section shows the labeled device diode protection diagram of PCA85074A.

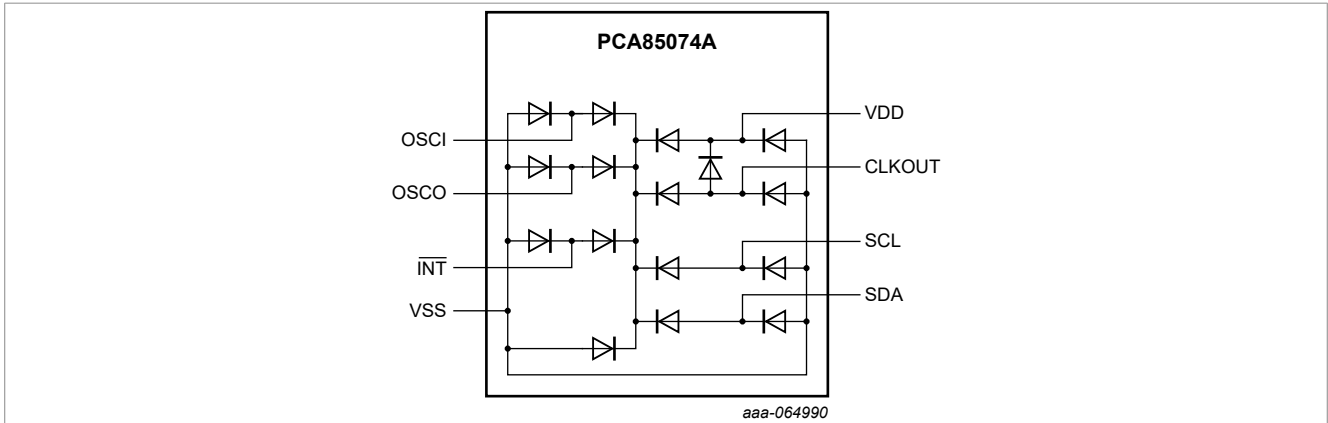

Figure 22. Device diode protection diagram of PCA85074A

## 10 Safety notes

### CAUTION



This device is sensitive to ElectroStatic Discharge (ESD). Observe precautions for handling electrostatic sensitive devices. Such precautions are described in the *ANSI/ESD S20.20*, *IEC/ST 61340-5*, *JESD625-A* or equivalent standards.

## 11 Limiting values

Table 39 describes the limiting values of PCA85074A.

Table 39. Limiting values<sup>[1]</sup>

In accordance with the Absolute Maximum Rating System (IEC 60134).

Symbol	Parameter	Conditions	Min	Max	Unit
V <sub>DD</sub>	Supply voltage		-0.5	+6.5	V
I <sub>DD</sub>	Supply current		-50	+50	mA
V <sub>I</sub>	Input voltage	On pins SCL, SDA, OSCI	-0.5	+6.5	V
V <sub>O</sub>	Output voltage		-0.5	+6.5	V
I <sub>I</sub>	Input current	At any input	-10	+10	mA
I <sub>O</sub>	Output current	At any output	-10	+10	mA
P <sub>tot</sub>	Total power dissipation		-	300	mW
T <sub>stg</sub>	Storage temperature		-65	+150	°C
T <sub>amb</sub>	Ambient temperature	Operating device	-40	+125	°C

[1] Remark: The PCA85074A part is not guaranteed (nor characterized) above the operating range as denoted in the data sheet. NXP recommends not to bias the PCA85074A device during reflow (for example, if utilizing a 'coin' type battery in the assembly). If the customer so chooses to continue to use this assembly method, there must be the allowance for a full 'Q0 V' level power supply 'Qreset' to re-enable the device. Without a proper POR, the device may remain in an indeterminate state.

## 12 Characteristics

[Table 40](#) and [Table 41](#) provides an overview of the characteristics.

**Table 40. Static characteristics**

$V_{DD} = 0.9\text{ V to }5.5\text{ V}$ ;  $V_{SS} = 0\text{ V}$ ;  $T_{amb} = -40\text{ °C to }+125\text{ °C}$ ;  $f_{osc} = 32.768\text{ kHz}$ ; quartz  $R_s = 60\text{ k}\Omega$ ;  $C_L = 7\text{ pF}$ ; unless otherwise specified.

Symbol	Parameter	Conditions	Note	Min	Typ	Max	Unit
<b>Supplies</b>							
$V_{DD}$	Supply voltage	Interface inactive; $f_{SCL} = 0\text{ Hz}$	[1]	0.9	-	5.5	V
		Interface active; $f_{SCL} = 400\text{ kHz}$	[1]	1.8	-	5.5	V
$I_{DD}$	Supply current	CLKOUT disabled; $V_{DD} = 5\text{ V}$	[2]				
		Interface inactive; $f_{SCL} = 0\text{ Hz}$					
		$T_{amb} = 25\text{ °C}$		-	250	450	nA
		$T_{amb} = 85\text{ °C}$		-	550	750	nA
		$T_{amb} = 105\text{ °C}$		-	900	1800	nA
		$T_{amb} = 125\text{ °C}$		-	2500	6000	nA
		Interface active; $f_{SCL} = 400\text{ kHz}$		-	35	50	$\mu\text{A}$
<b>Inputs</b> <sup>[3]</sup>							
$V_I$	Input voltage			$V_{SS}$	-	5.5	V
$V_{IL}$	LOW-level input voltage			$V_{SS}$	-	$0.3V_{DD}$	V
$V_{IH}$	HIGH-level input voltage			$0.7V_{DD}$	-	$V_{DD}$	V
$I_{LI}$	Input leakage current	$V_I = V_{SS}$ or $V_{DD}$		-1	0	+1	$\mu\text{A}$
		Post ESD event		-0.22	-	+0.22	$\mu\text{A}$
$C_i$	Input capacitance		[4]	-	-	7	pF
<b>Outputs</b>							
$V_{OH}$	HIGH-level output voltage	On pin CLKOUT		$0.8V_{DD}$	-	$V_{DD}$	V
$V_{OL}$	LOW-level output voltage	On pins SDA, INT, CLKOUT		$V_{SS}$	-	$0.2V_{DD}$	V

Table 40. Static characteristics...continued

V<sub>DD</sub> = 0.9 V to 5.5 V; V<sub>SS</sub> = 0 V; T<sub>amb</sub> = -40 °C to +125 °C; f<sub>osc</sub> = 32.768 kHz; quartz R<sub>s</sub> = 60 kΩ; C<sub>L</sub> = 7 pF; unless otherwise specified.

Symbol	Parameter	Conditions	Note	Min	Typ	Max	Unit
I <sub>OH</sub>	HIGH-level output current	Output source current; V <sub>OH</sub> = 4.6 V; V <sub>DD</sub> = 5 V; on pin CLKOUT		1	3	-	mA
I <sub>OL</sub>	LOW-level output current	Output sink current; V <sub>OL</sub> = 0.4 V; V <sub>DD</sub> = 5 V					
		on pin SDA		3	8.5	-	mA
		On pin INT		2	6	-	mA
		On pin CLKOUT		1	3	-	mA
<b>Oscillator</b>							
Δf <sub>osc</sub> /f <sub>osc</sub>	Relative oscillator frequency variation	ΔV <sub>DD</sub> = 200 mV; T <sub>amb</sub> = 25 °C		-	0.075	-	ppm
C <sub>L(itg)</sub>	Integrated load capacitance	On pins OSC0, OSC1	[5]				
		C <sub>L</sub> = 7 pF		4.2	7	9.8	pF
		C <sub>L</sub> = 12.5 pF		7.5	12.5	17.5	pF
R <sub>s</sub>	Series resistance			-	-	100	kΩ

[1] For reliable oscillator startup at power on use V<sub>DD</sub> greater than 1.2 V. If powered up at 0.9 V the oscillator starts but it might be a bit slow, especially if at high temperature. Normally the power supply is not 0.9 V at startup and only comes at the end of battery discharge. V<sub>DD</sub> min of 0.9 V is specified so that the customer can calculate how large a battery or capacitor they need for their application. V<sub>DD</sub> min of 1.2 V or greater is needed to ensure speedy oscillator startup time. For a restart condition, NXP recommends a full "0 V" V<sub>DD</sub> value upon re-biasing.

[2] Timer source clock = 1/60 Hz, level of pins SCL and SDA is V<sub>DD</sub> or V<sub>SS</sub>.

[3] The I<sup>2</sup>C-bus interface of the PCA85074A is 5 V tolerant.

[4] Implicit by design.

[5]

Integrated load capacitance, C<sub>L(itg)</sub>, is a calculation of C<sub>OSCI</sub> and C<sub>OSCO</sub> in series: 
$$C_{L(itg)} = \frac{C_{OSCI}C_{OSCO}}{C_{OSCI}+C_{OSCO}}$$

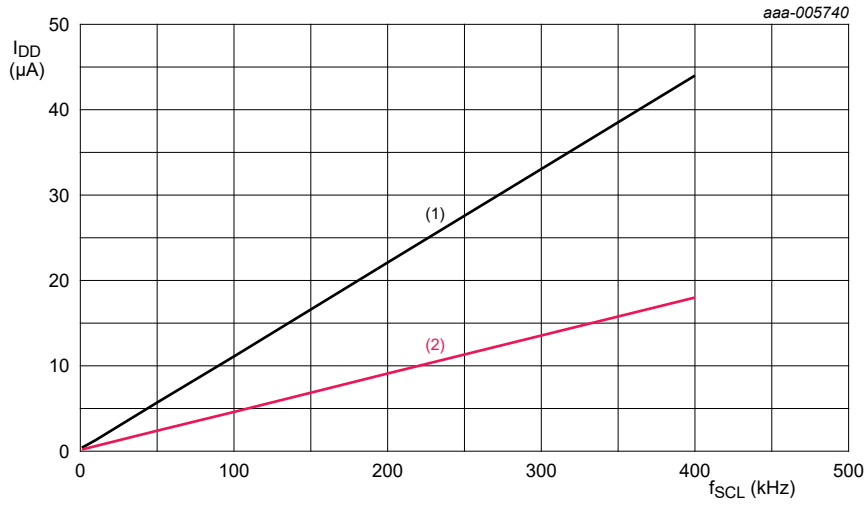

T<sub>amb</sub> = 25 °C; CLKOUT disabled.

1. V<sub>DD</sub> = 5.0 V.
2. V<sub>DD</sub> = 3.3 V.

Figure 23. Typical I<sub>DD</sub> with respect to f<sub>SCL</sub>

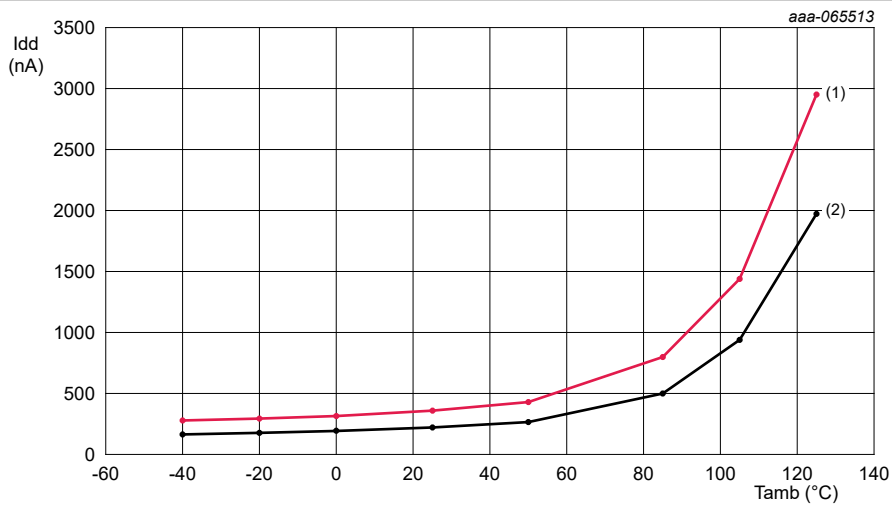

C<sub>L(itg)</sub> = 7 pF; CLKOUT disabled.

1. V<sub>DD</sub> = 5.5 V.
2. V<sub>DD</sub> = 3.3 V.

Figure 24. Typical I<sub>DD</sub> as a function of temperature when Control\_1.CAP\_SEL = 0b

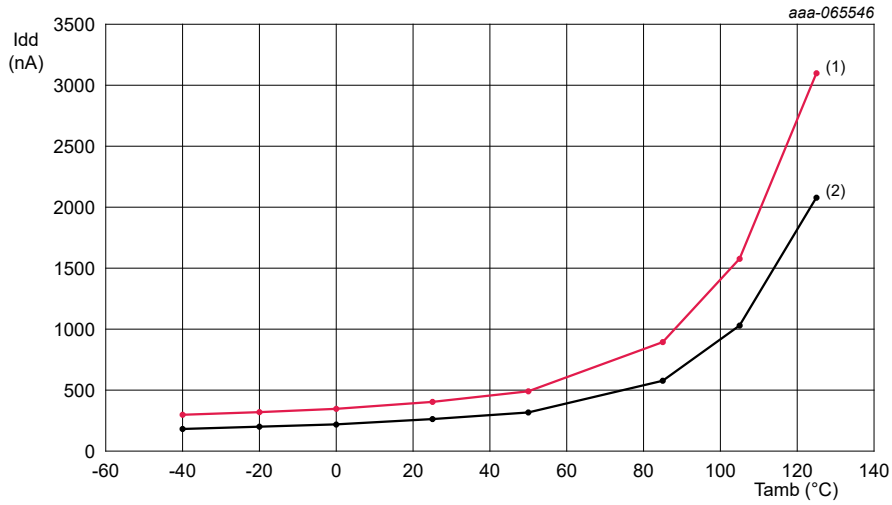

C<sub>L(itg)</sub> = 12.5 pF; CLKOUT disabled.

1. V<sub>DD</sub> = 5.5 V.
2. V<sub>DD</sub> = 3.3 V.

Figure 25. Typical I<sub>DD</sub> as a function of temperature when Control\_1.CAP\_SEL = 1b

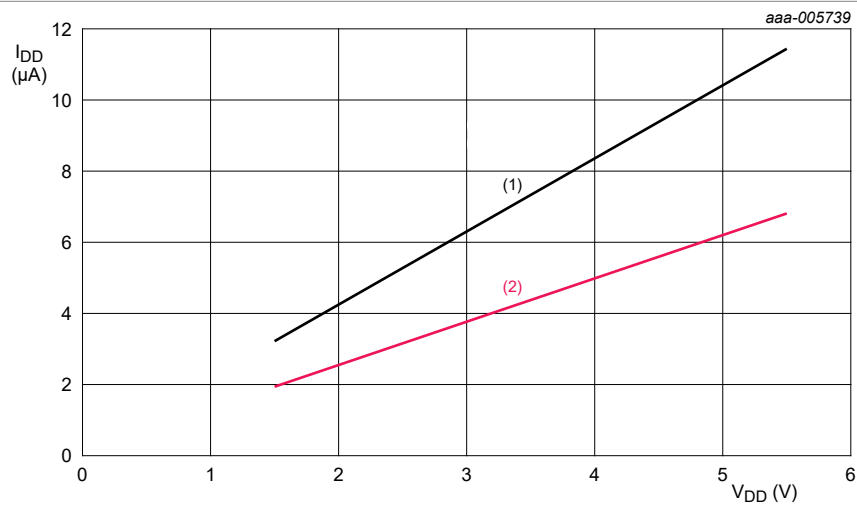

T<sub>amb</sub> = 25 °C; f<sub>CLKOUT</sub> = 32 768 Hz.

1. 47 pF CLKOUT load.
2. 22 pF CLKOUT load.

Figure 26. Typical I<sub>DD</sub> with respect to V<sub>DD</sub> when Control\_2.COF = 000b

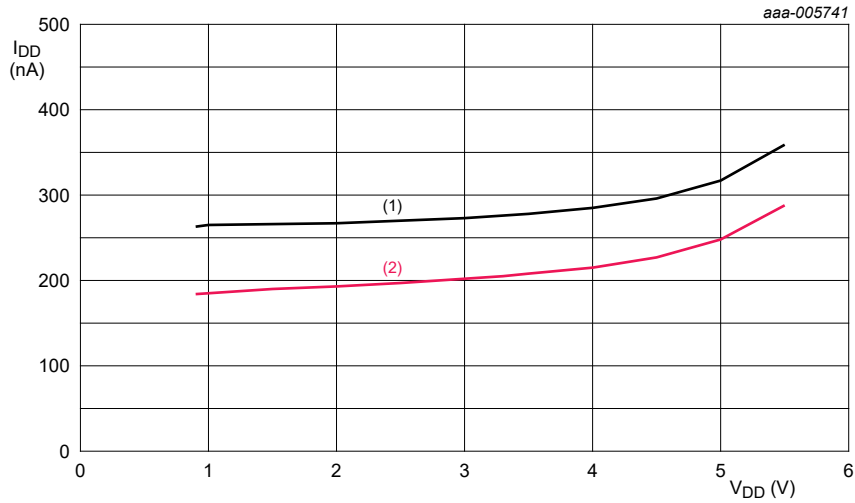

T<sub>amb</sub> = 25 °C; CLKOUT disabled.

1. C<sub>L(itg)</sub> = 12.5 pF.
2. C<sub>L(itg)</sub> = 7 pF.

Figure 27. Typical I<sub>DD</sub> with respect to V<sub>DD</sub> when Control\_2.COF = 111b

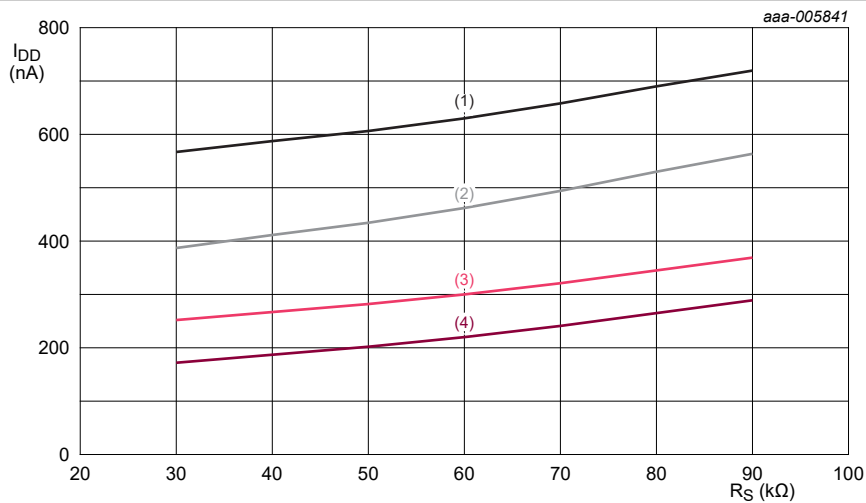

V<sub>DD</sub> = 5 V; CLKOUT disabled.

1. C<sub>L(itg)</sub> = 12.5 pF; 50 °C; maximum value.
2. C<sub>L(itg)</sub> = 7 pF; 50 °C; maximum value.
3. C<sub>L(itg)</sub> = 12.5 pF; 25 °C; typical value.
4. C<sub>L(itg)</sub> = 7 pF; 25 °C; typical value.

Figure 28. I<sub>DD</sub> with respect to quartz R<sub>S</sub>

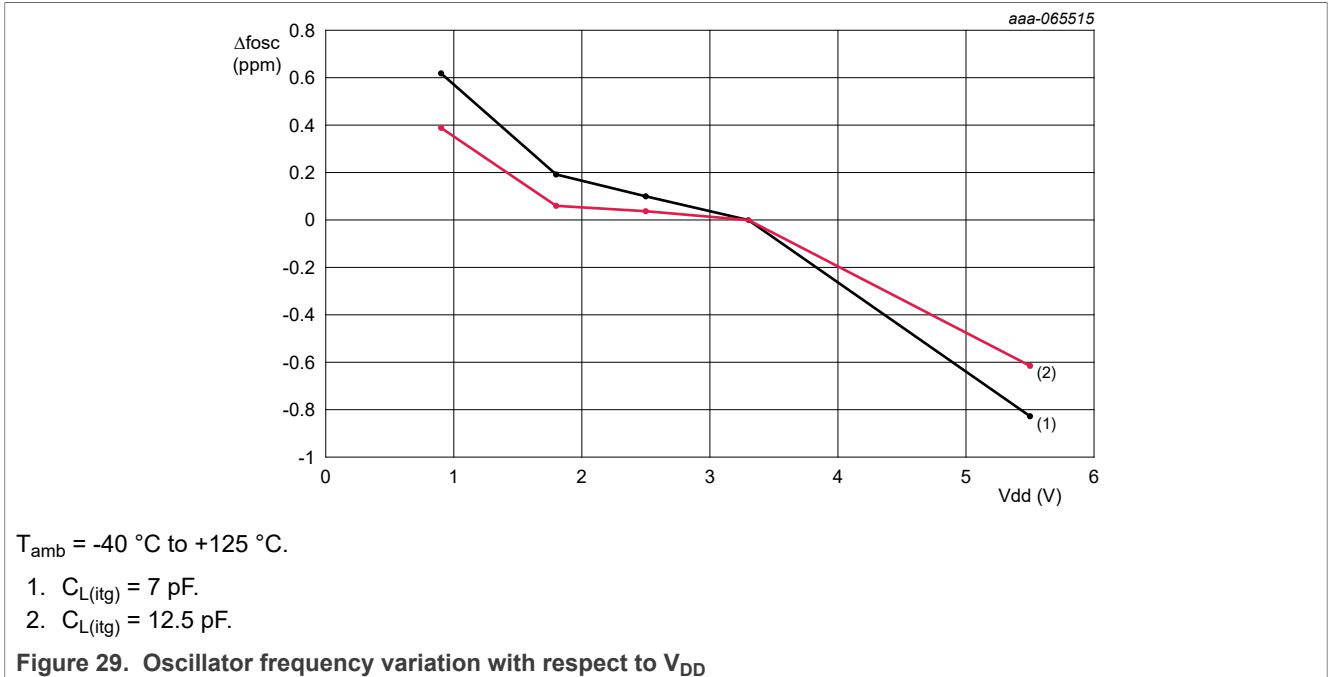

**Table 41. I<sup>2</sup>C-bus characteristics**

V<sub>DD</sub> = 1.8 V to 5.5 V; V<sub>SS</sub> = 0 V; T<sub>amb</sub> = -40 °C to +125 °C; f<sub>osc</sub> = 32.768 kHz; quartz R<sub>s</sub> = 60 kΩ; C<sub>L</sub> = 7 pF; unless otherwise specified. All timing values are valid within the operating supply voltage and temperature range and referenced to V<sub>IL</sub> and V<sub>IH</sub> with an input voltage swing of V<sub>SS</sub> to V<sub>DD</sub><sup>[1]</sup> up to 125 °C.

Symbol	Parameter	Conditions	Note	Min	Max	Unit
C <sub>b</sub>	Capacitive load for each bus line			-	400	pF
f <sub>SCL</sub>	SCL clock frequency		[2]	0	400	kHz
t <sub>HD;STA</sub>	Hold time (repeated) START condition			0.6	-	μs
t <sub>SU;STA</sub>	Set-up time for a repeated START condition			0.6	-	μs
t <sub>LOW</sub>	LOW period of the SCL clock			1.3	-	μs
t <sub>HIGH</sub>	HIGH period of the SCL clock			0.6	-	μs
t <sub>r</sub>	Rise time of both SDA and SCL signals			20	300	ns
t <sub>f</sub>	Fall time of both SDA and SCL signals		[3] [4]	20 × (V <sub>DD</sub> /5.5 V)	300	ns
t <sub>BUF</sub>	Bus free time between a STOP and START condition			1.3	-	μs
t <sub>SU;DAT</sub>	Data set-up time			100	-	ns
t <sub>HD;DAT</sub>	Data hold time			0	-	ns

Table 41. I<sup>2</sup>C-bus characteristics...continued

$V_{DD} = 1.8\text{ V to }5.5\text{ V}$ ;  $V_{SS} = 0\text{ V}$ ;  $T_{amb} = -40\text{ }^{\circ}\text{C to }+125\text{ }^{\circ}\text{C}$ ;  $f_{osc} = 32.768\text{ kHz}$ ; quartz  $R_s = 60\text{ k}\Omega$ ;  $C_L = 7\text{ pF}$ ; unless otherwise specified. All timing values are valid within the operating supply voltage and temperature range and referenced to  $V_{IL}$  and  $V_{IH}$  with an input voltage swing of  $V_{SS}$  to  $V_{DD}$ <sup>[1]</sup> up to 125 °C.

Symbol	Parameter	Conditions	Note	Min	Max	Unit
t <sub>SU;STO</sub>	Set-up time for STOP condition			0.6	-	μs
t <sub>VD;DAT</sub>	Data valid time			0	0.9	μs
t <sub>VD;ACK</sub>	Data valid acknowledge time			0	0.9	μs
t <sub>SP</sub>	Pulse width of spikes that must be suppressed by the input filter			0	50	ns

- [1] A detailed description of the I<sup>2</sup>C-bus specification is given in [ref.\[2\]](#).
- [2] I<sup>2</sup>C-bus access time between two STARTs or between a START and a STOP condition to this device must be less than one second.
- [3] A device must internally provide a hold time of at least 300 ns for the SDA signal (with respect to the  $V_{IH(min)}$  of the SCL signal) to bridge the undefined region of the falling edge of SCL.
- [4] The maximum t<sub>r</sub> for the SDA and SCL bus lines is specified at 300 ns. The maximum fall time for the SDA output stage t<sub>f</sub> is specified at 250 ns. This allows series protection resistors to be connected in between the SDA and the SCL pins and the SDA/SCL bus lines without exceeding the maximum specified t<sub>r</sub>.

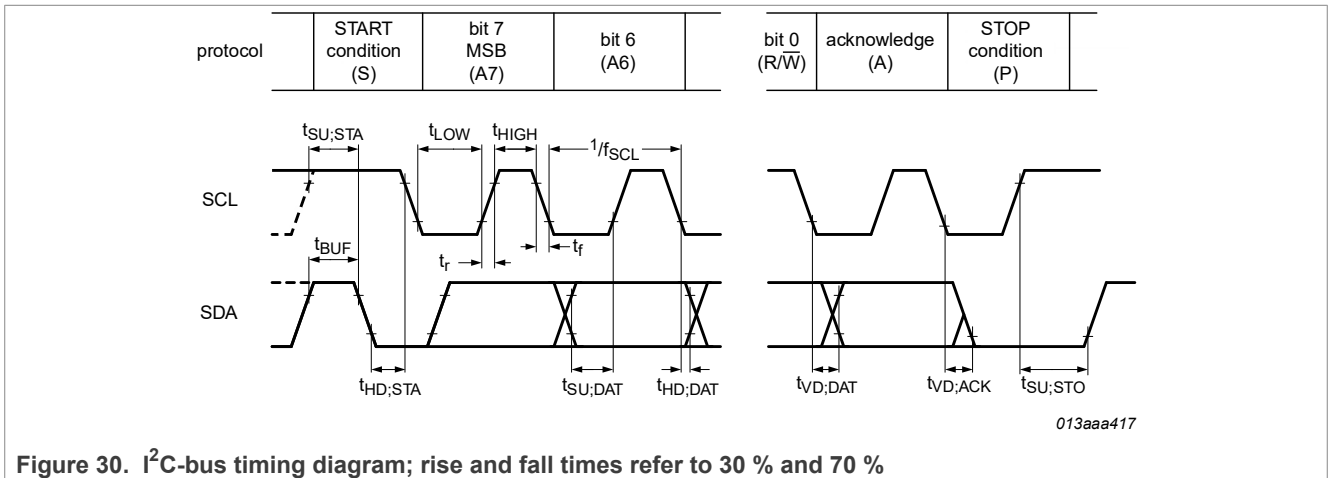
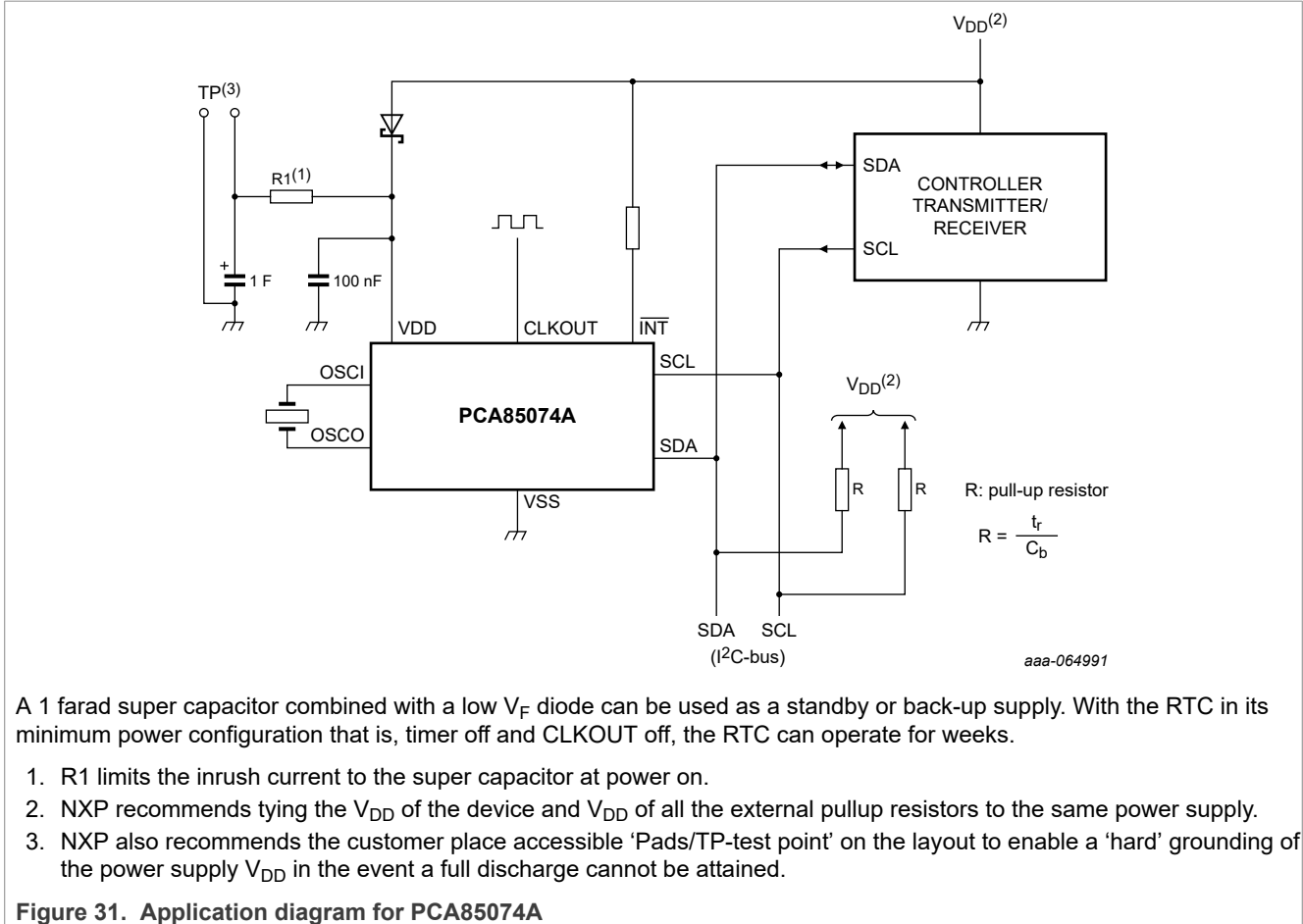

Figure 30. I<sup>2</sup>C-bus timing diagram; rise and fall times refer to 30 % and 70 %

### 13 Application information

This section shows the application diagram for PCA85074A.



A 1 farad super capacitor combined with a low  $V_F$  diode can be used as a standby or back-up supply. With the RTC in its minimum power configuration that is, timer off and CLKOUT off, the RTC can operate for weeks.

1. R1 limits the inrush current to the super capacitor at power on.
2. NXP recommends tying the  $V_{DD}$  of the device and  $V_{DD}$  of all the external pullup resistors to the same power supply.
3. NXP also recommends the customer place accessible 'Pads/TP-test point' on the layout to enable a 'hard' grounding of the power supply  $V_{DD}$  in the event a full discharge cannot be attained.

Figure 31. Application diagram for PCA85074A

## 14 Test information

This section covers the quality information of the PCA85074A.

### 14.1 Quality information

This product has been qualified in accordance with the Automotive Electronics Council (AEC) standard Q100 - *Failure mechanism based stress test qualification for integrated circuits*. It is suitable for use in automotive applications.

## 15 Package outline

This section shows the package outline for the PCA85074A.

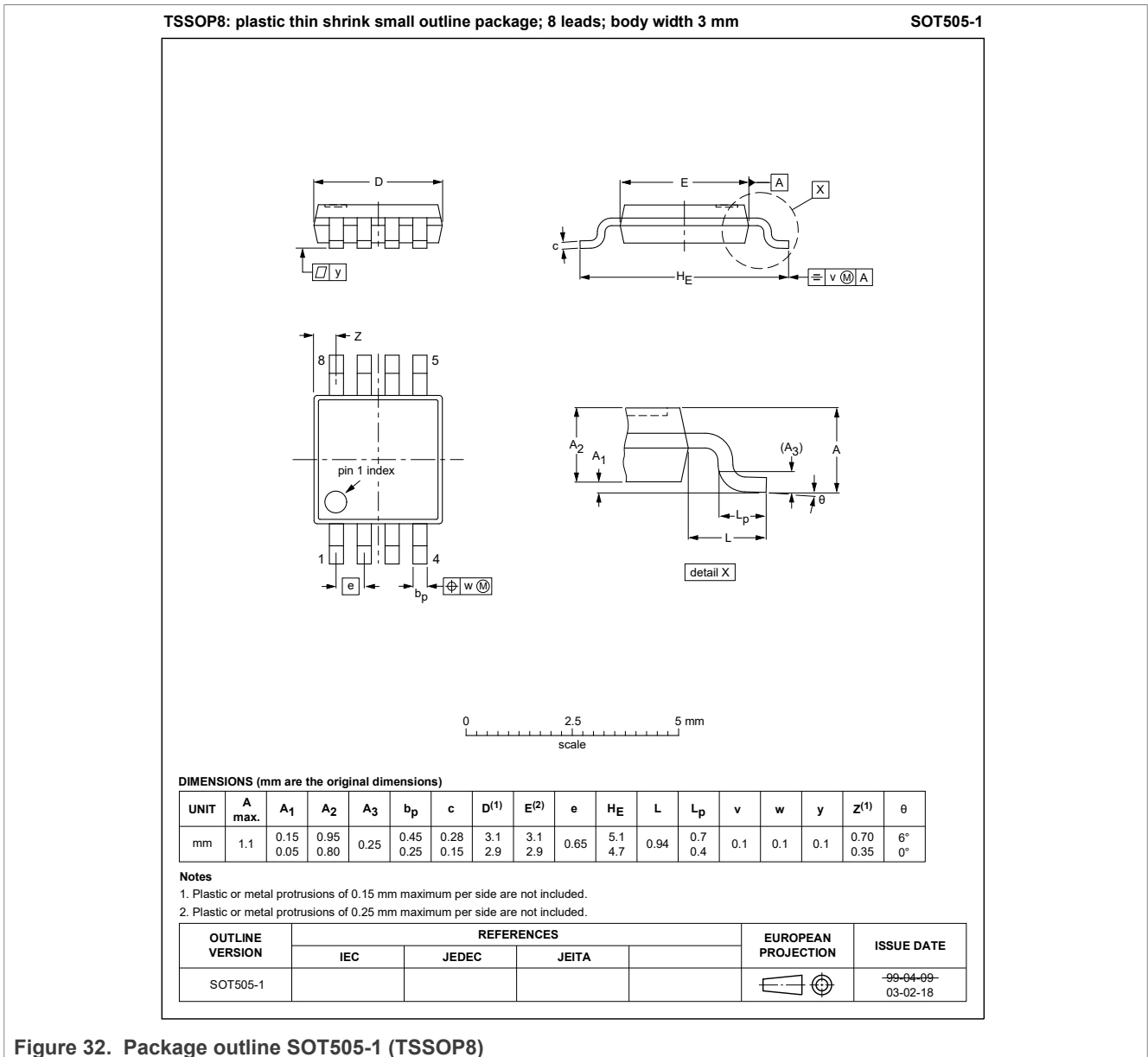

Figure 32. Package outline SOT505-1 (TSSOP8)

## 16 Handling information

---

All input and output pins are protected against ElectroStatic Discharge (ESD) under normal handling. When handling Metal-Oxide Semiconductor (MOS) devices ensure that all normal precautions are taken as described in *JESD625-A*, *IEC 61340-5* or equivalent standards.

## 17 Packing information

---

This section provides tape and reel information for the PCA85074A.

### 17.1 Tape and reel information

For tape and reel packing information, see [ref.\[1\]](#).

## 18 Soldering of SMD packages

---

This text provides a very brief insight into a complex technology. A more in-depth account of soldering ICs can be found in Application Note *AN10365 "Surface mount reflow soldering description"*.

### 18.1 Introduction to soldering

Soldering is one of the most common methods through which packages are attached to Printed Circuit Boards (PCBs), to form electrical circuits. The soldered joint provides both the mechanical and the electrical connection. There is no single soldering method that is ideal for all IC packages. Wave soldering is often preferred when through-hole and Surface Mount Devices (SMDs) are mixed on one printed wiring board; however, it is not suitable for fine pitch SMDs. Reflow soldering is ideal for the small pitches and high densities that come with increased miniaturization.

### 18.2 Wave and reflow soldering

Wave soldering is a joining technology in which the joints are made by solder coming from a standing wave of liquid solder. The wave soldering process is suitable for the following:

- Through-hole components
- Leaded or leadless SMDs, which are glued to the surface of the printed circuit board

Not all SMDs can be wave soldered. Packages with solder balls, and some leadless packages which have solder lands underneath the body, cannot be wave soldered. Also, leaded SMDs with leads having a pitch smaller than ~0.6 mm cannot be wave soldered, due to an increased probability of bridging.

The reflow soldering process involves applying solder paste to a board, followed by component placement and exposure to a temperature profile. Leaded packages, packages with solder balls, and leadless packages are all reflow solderable.

Key characteristics in both wave and reflow soldering are:

- Board specifications, including the board finish, solder masks and vias
- Package footprints, including solder thieves and orientation
- The moisture sensitivity level of the packages
- Package placement
- Inspection and repair
- Lead-free soldering versus SnPb soldering

### 18.3 Wave soldering

Key characteristics in wave soldering are:

- Process issues, such as application of adhesive and flux, clinching of leads, board transport, the solder wave parameters, and the time during which components are exposed to the wave
- Solder bath specifications, including temperature and impurities

### 18.4 Reflow soldering

Key characteristics in reflow soldering are:

- Lead-free versus SnPb soldering; note that a lead-free reflow process usually leads to higher minimum peak temperatures (see [Figure 33](#)) than a SnPb process, thus reducing the process window
- Solder paste printing issues including smearing, release, and adjusting the process window for a mix of large and small components on one board
- Reflow temperature profile; this profile includes preheat, reflow (in which the board is heated to the peak temperature) and cooling down. It is imperative that the peak temperature is high enough for the solder to make reliable solder joints (a solder paste characteristic). In addition, the peak temperature must be low enough that the packages and/or boards are not damaged. The peak temperature of the package depends on package thickness and volume and is classified in accordance with [Table 42](#) and [Table 43](#)

Table 42. SnPb eutectic process (from J-STD-020D)

Package thickness (mm)	Package reflow temperature (°C)	
	Volume (mm <sup>3</sup> )	
	< 350	≥ 350
< 2.5	235	220
≥ 2.5	220	220

Table 43. Lead-free process (from J-STD-020D)

Package thickness (mm)	Package reflow temperature (°C)		
	Volume (mm <sup>3</sup> )		
	< 350	350 to 2000	> 2000
< 1.6	260	260	260
1.6 to 2.5	260	250	245
> 2.5	250	245	245

Moisture sensitivity precautions, as indicated on the packing, must be respected at all times.

Studies have shown that small packages reach higher temperatures during reflow soldering, see [Figure 33](#).

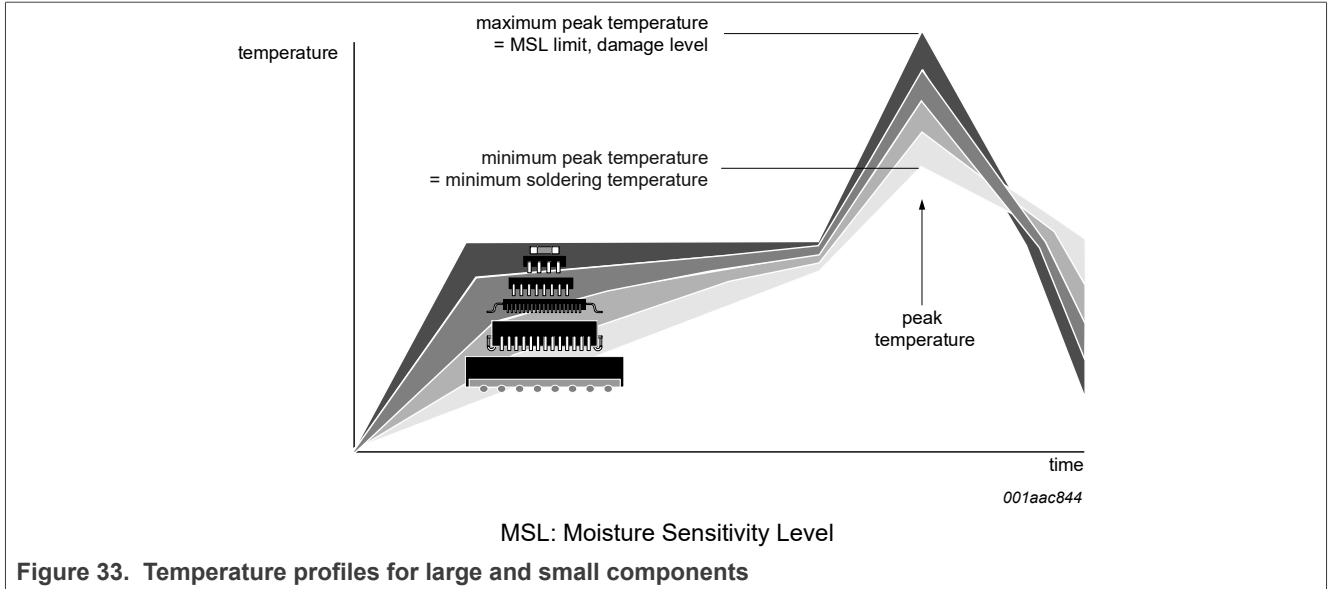

Figure 33. Temperature profiles for large and small components

For further information on temperature profiles, refer to Application Note AN10365 “Surface mount reflow soldering description”.

## 19 Footprint information

This section shows the footprint information for the PCA85074A.

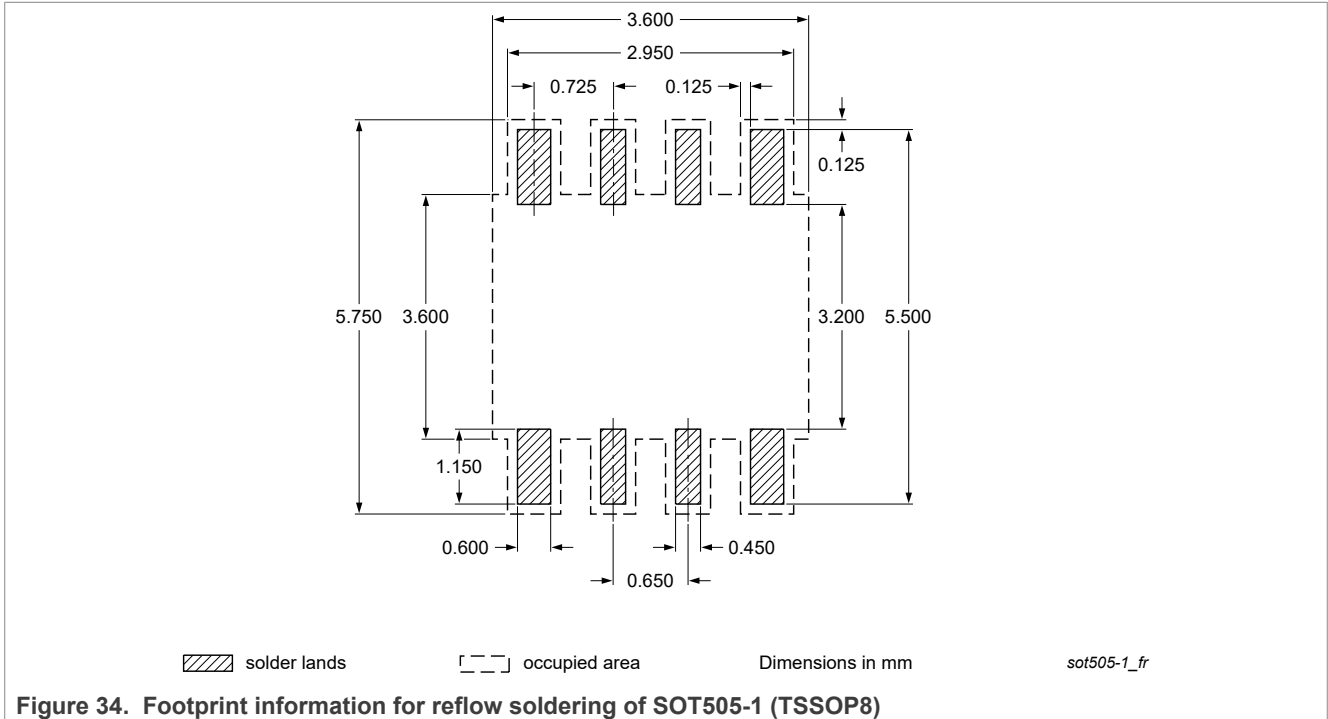

Figure 34. Footprint information for reflow soldering of SOT505-1 (TSSOP8)

## 20 Acronyms

This section lists the acronyms used in this document.

Table 44. Acronyms

Acronym	Description
AEC	Automotive Electronics Council
ANSI	American National Standards Institute
BCD	Binary Coded Decimal
CMOS	Complementary Metal Oxide Semiconductor
COF	Chip on Flex
ESD	ElectroStatic Discharge
HBM	Human Body Model
HMI	Human-Machine Interface
I <sup>2</sup> C	Inter-Integrated Circuit
IC	Integrated Circuit
LSB	Least Significant Bit
MOS	Metal-Oxide Semiconductor
MSB	Most Significant Bit
MSL	Moisture Sensitivity Level
PCB	Printed-Circuit Board
POR	Power-on Reset
RTC	Real-Time Clock
SCL	Serial Clock line
SDA	Serial Data line
SMD	Surface Mount Device
SSB	Static Shielding Bag

## 21 References

This section lists the references used to supplement this document.

- [1] **SOT505-1\_118** TSSOP8; Reel pack; SMD, 13", packing information
- [2] **UM10204** I<sup>2</sup>C-bus specification and user manual
- [3] **UM10301** User Manual for NXP Real Time Clocks PCF85x3, PCA8565 and PCF2123, PCA2125

## 22 Revision history

[Table 45](#) summarizes the revisions to this document.

**Table 45. Revision history**

Document ID	Release date	Description
PCA85074A v.2.0	04 June 2026	Initial public release
PCA85074A v.1.0	14 May 2026	Initial NDA Preliminary data sheet

## Legal information

### Data sheet status

Document status <sup>[1][2]</sup>	Product status <sup>[3]</sup>	Definition
Objective [short] data sheet	Development	This document contains data from the objective specification for product development.
Preliminary [short] data sheet	Qualification	This document contains data from the preliminary specification.
Product [short] data sheet	Production	This document contains the product specification.

[1] Please consult the most recently issued document before initiating or completing a design.

[2] The term 'short data sheet' is explained in section "Definitions".

[3] The product status of device(s) described in this document may have changed since this document was published and may differ in case of multiple devices. The latest product status information is available on the Internet at URL <https://www.nxp.com>.

### Definitions

**Draft** — A draft status on a document indicates that the content is still under internal review and subject to formal approval, which may result in modifications or additions. NXP Semiconductors does not give any representations or warranties as to the accuracy or completeness of information included in a draft version of a document and shall have no liability for the consequences of use of such information.

**Short data sheet** — A short data sheet is an extract from a full data sheet with the same product type number(s) and title. A short data sheet is intended for quick reference only and should not be relied upon to contain detailed and full information. For detailed and full information see the relevant full data sheet, which is available on request via the local NXP Semiconductors sales office. In case of any inconsistency or conflict with the short data sheet, the full data sheet shall prevail.

**Product specification** — The information and data provided in a Product data sheet shall define the specification of the product as agreed between NXP Semiconductors and its customer, unless NXP Semiconductors and customer have explicitly agreed otherwise in writing. In no event however, shall an agreement be valid in which the NXP Semiconductors product is deemed to offer functions and qualities beyond those described in the Product data sheet.

### Disclaimers

**Limited warranty and liability** — Information in this document is believed to be accurate and reliable. However, NXP Semiconductors does not give any representations or warranties, expressed or implied, as to the accuracy or completeness of such information and shall have no liability for the consequences of use of such information. NXP Semiconductors takes no responsibility for the content in this document if provided by an information source outside of NXP Semiconductors.

In no event shall NXP Semiconductors be liable for any indirect, incidental, punitive, special or consequential damages (including - without limitation - lost profits, lost savings, business interruption, costs related to the removal or replacement of any products or rework charges) whether or not such damages are based on tort (including negligence), warranty, breach of contract or any other legal theory.

Notwithstanding any damages that customer might incur for any reason whatsoever, NXP Semiconductors' aggregate and cumulative liability towards customer for the products described herein shall be limited in accordance with the Terms and conditions of commercial sale of NXP Semiconductors.

**Right to make changes** — NXP Semiconductors reserves the right to make changes to information published in this document, including without limitation specifications and product descriptions, at any time and without notice. This document supersedes and replaces all information supplied prior to the publication hereof.

**Suitability for use** — NXP Semiconductors products are not designed, authorized or warranted to be suitable for use in life support, life-critical or safety-critical systems or equipment, nor in applications where failure or malfunction of an NXP Semiconductors product can reasonably be expected to result in personal injury, death or severe property or environmental damage. NXP Semiconductors and its suppliers accept no liability for inclusion and/or use of NXP Semiconductors products in such equipment or applications and therefore such inclusion and/or use is at the customer's own risk.

**Applications** — Applications that are described herein for any of these products are for illustrative purposes only. NXP Semiconductors makes no representation or warranty that such applications will be suitable for the specified use without further testing or modification.

Customers are responsible for the design and operation of their applications and products using NXP Semiconductors products, and NXP Semiconductors accepts no liability for any assistance with applications or customer product design. It is customer's sole responsibility to determine whether the NXP Semiconductors product is suitable and fit for the customer's applications and products planned, as well as for the planned application and use of customer's third party customer(s). Customers should provide appropriate design and operating safeguards to minimize the risks associated with their applications and products.

NXP Semiconductors does not accept any liability related to any default, damage, costs or problem which is based on any weakness or default in the customer's applications or products, or the application or use by customer's third party customer(s). Customer is responsible for doing all necessary testing for the customer's applications and products using NXP Semiconductors products in order to avoid a default of the applications and the products or of the application or use by customer's third party customer(s). NXP does not accept any liability in this respect.

**Limiting values** — Stress above one or more limiting values (as defined in the Absolute Maximum Ratings System of IEC 60134) will cause permanent damage to the device. Limiting values are stress ratings only and (proper) operation of the device at these or any other conditions above those given in the Recommended operating conditions section (if present) or the Characteristics sections of this document is not warranted. Constant or repeated exposure to limiting values will permanently and irreversibly affect the quality and reliability of the device.

**Terms and conditions of commercial sale** — NXP Semiconductors products are sold subject to the general terms and conditions of commercial sale, as published at <https://www.nxp.com/profile/terms>, unless otherwise agreed in a valid written individual agreement. In case an individual agreement is concluded only the terms and conditions of the respective agreement shall apply. NXP Semiconductors hereby expressly objects to applying the customer's general terms and conditions with regard to the purchase of NXP Semiconductors products by customer.

**No offer to sell or license** — Nothing in this document may be interpreted or construed as an offer to sell products that is open for acceptance or the grant, conveyance or implication of any license under any copyrights, patents or other industrial or intellectual property rights.

**Quick reference data** — The Quick reference data is an extract of the product data given in the Limiting values and Characteristics sections of this document, and as such is not complete, exhaustive or legally binding.

**Export control** — This document as well as the item(s) described herein may be subject to export control regulations. Export might require a prior authorization from competent authorities.

**Suitability for use in non-automotive qualified products** — Unless this document expressly states that this specific NXP Semiconductors product is automotive qualified, the product is not suitable for automotive use. It is neither qualified nor tested in accordance with automotive testing or application requirements. NXP Semiconductors accepts no liability for inclusion and/or use of non-automotive qualified products in automotive equipment or applications.

In the event that customer uses the product for design-in and use in automotive applications to automotive specifications and standards, customer (a) shall use the product without NXP Semiconductors' warranty of the product for such automotive applications, use and specifications, and (b) whenever customer uses the product for automotive applications beyond NXP Semiconductors' specifications such use shall be solely at customer's own risk, and (c) customer fully indemnifies NXP Semiconductors for any liability, damages or failed product claims resulting from customer design and use of the product for automotive applications beyond NXP Semiconductors' standard warranty and NXP Semiconductors' product specifications.

**HTML publications** — An HTML version, if available, of this document is provided as a courtesy. Definitive information is contained in the applicable document in PDF format. If there is a discrepancy between the HTML document and the PDF document, the PDF document has priority.

**Translations** — A non-English (translated) version of a document, including the legal information in that document, is for reference only. The English version shall prevail in case of any discrepancy between the translated and English versions.

**Security** — Customer understands that all NXP products may be subject to unidentified vulnerabilities or may support established security standards or specifications with known limitations. Customer is responsible for the design and operation of its applications and products throughout their lifecycles to reduce the effect of these vulnerabilities on customer's applications and products. Customer's responsibility also extends to other open and/or proprietary technologies supported by NXP products for use in customer's applications. NXP accepts no liability for any vulnerability. Customer should regularly check security updates from NXP and follow up appropriately.

Customer shall select products with security features that best meet rules, regulations, and standards of the intended application and make the ultimate design decisions regarding its products and is solely responsible for compliance with all legal, regulatory, and security related requirements concerning its products, regardless of any information or support that may be provided by NXP.

NXP has a Product Security Incident Response Team (PSIRT) (reachable at [PSIRT@nxp.com](mailto:PSIRT@nxp.com)) that manages the investigation, reporting, and solution release to security vulnerabilities of NXP products.

**NXP B.V.** — NXP B.V. is not an operating company and it does not distribute or sell products.

## Trademarks

Notice: All referenced brands, product names, service names, and trademarks are the property of their respective owners.

**NXP** — wordmark and logo are trademarks of NXP B.V.

**I<sup>2</sup>C-bus** — logo is a trademark of NXP B.V.

Tables

Tab. 1.	Ordering information	2	Tab. 23.	Weekdays - weekdays register (address 08h) bit description	19
Tab. 2.	Ordering options	2	Tab. 24.	Weekday assignments	19
Tab. 3.	Pin description	4	Tab. 25.	Months - months register (address 09h) bit description	20
Tab. 4.	Registers overview	5	Tab. 26.	Month assignments in BCD format	20
Tab. 5.	Control_1 - control and status register 1 (address 00h) bit description	5	Tab. 27.	Years - years register (0Ah) bit description	20
Tab. 6.	First increment of time circuits after stop bit release	7	Tab. 28.	Second_alarm - second alarm register (address 0Bh) bit description	22
Tab. 7.	Registers reset values	8	Tab. 29.	Minute_alarm - minute alarm register (address 0Ch) bit description	22
Tab. 8.	Control_2 - control and status register 2 (address 01h) bit description	9	Tab. 30.	Hour_alarm - hour alarm register (address 0Dh) bit description	22
Tab. 9.	Effect of bits MI and HMI on INT generation	11	Tab. 31.	Day_alarm - day alarm register (address 0Eh) bit description	23
Tab. 10.	CLKOUT frequency selection	12	Tab. 32.	Weekday_alarm - weekday alarm register (address 0Fh) bit description	23
Tab. 11.	Offset - offset register (address 02h) bit description	12	Tab. 33.	Timer_value - timer value register (address 10h) bit description	25
Tab. 12.	Offset values	13	Tab. 34.	Timer_mode - timer control register (address 11h) bit description	25
Tab. 13.	Correction pulses for MODE = 0	13	Tab. 35.	Timer clock frequency and timer durations	26
Tab. 14.	Effect of correction pulses on frequencies for MODE = 0	14	Tab. 36.	First period delay for timer counter value T	27
Tab. 15.	Correction pulses for MODE = 1	15	Tab. 37.	INT operation	27
Tab. 16.	Effect of correction pulses on frequencies for MODE = 1	15	Tab. 38.	I2C target address byte	29
Tab. 17.	RAM_byte - 8-bit RAM register (address 03h) bit description	17	Tab. 39.	Limiting values	31
Tab. 18.	Seconds - seconds register (address 04h) bit description	17	Tab. 40.	Static characteristics	32
Tab. 19.	Seconds coded in BCD format	17	Tab. 41.	I2C-bus characteristics	37
Tab. 20.	Minutes - minutes register (address 05h) bit description	18	Tab. 42.	SnPb eutectic process (from J-STD-020D)	42
Tab. 21.	Hours - hours register (address 06h) bit description	18	Tab. 43.	Lead-free process (from J-STD-020D)	42
Tab. 22.	Days - days register (address 07h) bit description	19	Tab. 44.	Acronyms	44
			Tab. 45.	Revision history	45

Figures

Fig. 1.	Block diagram of PCA85074A	3	Fig. 19.	Acknowledgment on the I2C-bus	29
Fig. 2.	Pin configuration for TSSOP8 (PCA85074ADP)	3	Fig. 20.	Controller transmits to target receiver (WRITE mode)	30
Fig. 3.	Handling address registers	4	Fig. 21.	Controller reads after setting register address (write register address; READ data)	30
Fig. 4.	Stop bit functional diagram	6	Fig. 22.	Device diode protection diagram of PCA85074A	31
Fig. 5.	Stop bit release timing	8	Fig. 23.	Typical IDD with respect to fSCL	34
Fig. 6.	Software reset command	8	Fig. 24.	Typical IDD as a function of temperature when Control_1.CAP_SEL = 0b	34
Fig. 7.	Interrupt scheme	10	Fig. 25.	Typical IDD as a function of temperature when Control_1.CAP_SEL = 1b	35
Fig. 8.	INT example for MI	11	Fig. 26.	Typical IDD with respect to VDD when Control_2.COF = 000b	35
Fig. 9.	Offset calibration calculation workflow	16	Fig. 27.	Typical IDD with respect to VDD when Control_2.COF = 111b	36
Fig. 10.	Result of offset calibration	16	Fig. 28.	IDD with respect to quartz RS	36
Fig. 11.	OS flag	18			
Fig. 12.	Data flow for the time function	21			
Fig. 13.	Access time for read/write operations	21			
Fig. 14.	Alarm function block diagram	24			
Fig. 15.	General countdown timer behavior	26			
Fig. 16.	Bit transfer	28			
Fig. 17.	Definition of START and STOP conditions	28			
Fig. 18.	System configuration	28			

Fig. 29.	Oscillator frequency variation with respect to VDD .....	37	Fig. 32.	Package outline SOT505-1 (TSSOP8) .....	40
Fig. 30.	I2C-bus timing diagram; rise and fall times refer to 30 % and 70 % .....	38	Fig. 33.	Temperature profiles for large and small components .....	43
Fig. 31.	Application diagram for PCA85074A .....	39	Fig. 34.	Footprint information for reflow soldering of SOT505-1 (TSSOP8) .....	43

## Contents

<b>1</b>	<b>General description</b> .....	<b>1</b>	8.5	I2C-bus protocol .....	29
<b>2</b>	<b>Features and benefits</b> .....	<b>1</b>	8.5.1	Addressing .....	29
<b>3</b>	<b>Applications</b> .....	<b>1</b>	8.5.2	Clock and calendar READ or WRITE cycles ....	30
<b>4</b>	<b>Ordering information</b> .....	<b>2</b>	8.5.3	I2C-bus error recovery technique .....	30
4.1	Ordering options .....	2	<b>9</b>	<b>Internal circuitry</b> .....	<b>31</b>
<b>5</b>	<b>Block diagram</b> .....	<b>3</b>	<b>10</b>	<b>Safety notes</b> .....	<b>31</b>
<b>6</b>	<b>Pinning information</b> .....	<b>3</b>	<b>11</b>	<b>Limiting values</b> .....	<b>31</b>
6.1	Pinning .....	3	<b>12</b>	<b>Characteristics</b> .....	<b>32</b>
6.2	Pin description .....	4	<b>13</b>	<b>Application information</b> .....	<b>39</b>
<b>7</b>	<b>Functional description</b> .....	<b>4</b>	<b>14</b>	<b>Test information</b> .....	<b>40</b>
7.1	Registers organization .....	5	14.1	Quality information .....	40
7.2	Control registers .....	5	<b>15</b>	<b>Package outline</b> .....	<b>40</b>
7.2.1	Register Control_1 .....	5	<b>16</b>	<b>Handling information</b> .....	<b>41</b>
7.2.1.1	STOP: Stop bit function .....	6	<b>17</b>	<b>Packing information</b> .....	<b>41</b>
7.2.1.2	Software reset .....	8	17.1	Tape and reel information .....	41
7.2.2	Register Control_2 .....	9	<b>18</b>	<b>Soldering of SMD packages</b> .....	<b>41</b>
7.2.2.1	Alarm interrupt .....	10	18.1	Introduction to soldering .....	41
7.2.2.2	MI and HMI: minute and a half minute interrupt .....	11	18.2	Wave and reflow soldering .....	41
7.2.2.3	TF: timer flag .....	11	18.3	Wave soldering .....	42
7.2.2.4	COF[2:0]: Clock output frequency .....	12	18.4	Reflow soldering .....	42
7.2.3	Register Offset .....	12	<b>19</b>	<b>Footprint information</b> .....	<b>43</b>
7.2.3.1	Correction when MODE = 0 .....	13	<b>20</b>	<b>Acronyms</b> .....	<b>44</b>
7.2.3.2	Correction when MODE = 1 .....	14	<b>21</b>	<b>References</b> .....	<b>44</b>
7.2.3.3	Offset calibration workflow .....	15	<b>22</b>	<b>Revision history</b> .....	<b>45</b>
7.2.4	Register RAM_byte .....	17		<b>Legal information</b> .....	<b>46</b>
7.3	Time and date registers .....	17			
7.3.1	Register Seconds .....	17			
7.3.1.1	OS: Oscillator stop .....	18			
7.3.2	Register Minutes .....	18			
7.3.3	Register Hours .....	18			
7.3.4	Register Days .....	19			
7.3.5	Register Weekdays .....	19			
7.3.6	Register Months .....	20			
7.3.7	Register Years .....	20			
7.4	Setting and reading the time .....	20			
7.5	Alarm registers .....	22			
7.5.1	Register Second_alarm .....	22			
7.5.2	Register Minute_alarm .....	22			
7.5.3	Register Hour_alarm .....	22			
7.5.4	Register Day_alarm .....	23			
7.5.5	Register Weekday_alarm .....	23			
7.5.6	Alarm function .....	24			
7.6	Timer registers .....	24			
7.6.1	Register Timer_value .....	25			
7.6.2	Register Timer_mode .....	25			
7.6.3	Timer functions .....	25			
7.6.3.1	Countdown timer interrupts .....	27			
<b>8</b>	<b>Characteristics of the I2C-bus interface</b> .....	<b>27</b>			
8.1	Bit transfer .....	28			
8.2	START and STOP conditions .....	28			
8.3	System configuration .....	28			
8.4	Acknowledge .....	28			

Please be aware that important notices concerning this document and the product(s) described herein, have been included in section 'Legal information'.