

Errata to

MPC533RMAD/D  
Rev. 0, 9/2003

MPC533 Preliminary  
Reference Manual



**MOTOROLA**  
intelligence everywhere™

digital dna™

This errata describes corrections to the *MPC533 Preliminary Reference Manual*. These corrections also apply to the MPC534. For convenience, the section number and page number of the errata item in the reference manual are provided.

To locate any published updates for this document, refer to the world-wide web at <http://motorola.com/semiconductors>.

Section, Page No.	Changes
2.1, 2-2	In Figure 2-1, remove all references to TouCAN module C. This module is not implemented on the MPC533. Signals affected: C_CNrx0 and C_CNtX0 (in QSMCM and MIOs14 signal groupings).
2.2, 2-13/2-20	In Table 2-1, remove all references to: QADC64E module B, this module is not implemented on the MPC533. Signals affected: B_ANn / B_ANx/ B_PQBn TouCAN module C, this module is not implemented on the MPC533. Signals affected: C_CNrx0 and C_CNtX0
2.2, 2-19	In Table 2-1, IRAMSTBY delete the following text: “DPTRAM (8-Kbyte SRAM)”
2.2.1, 2-21	In Table 2-2, delete the first two rows of the table. TouCAN_C is not implemented on the MPC533; therefore, the C_CNrx0 and C_CNtX0 signals are not implemented.
2.4, 2-23	Updated section with previously omitted information pertaining to PDMCR2 field descriptions and TCNC functionality.
Chapter 16, 16-1	Replace the first paragraph with the following: The MPC533 contains one CAN 2.0B controller modules (TouCAN). The TouCAN is a communication controller that implements the Controller Area Network (CAN) protocol, an asynchronous communications protocol used in automotive and industrial control systems. It is a high speed (one Mbit/sec), short distance, priority based protocol that can run over a variety of mediums (for example, fiber optic cable or an unshielded twisted pair of wires). The TouCAN supports both the standard and extended identifier (ID) message formats specified in the CAN protocol specification, revision 2.0, part B.
16.2.1, 16-3	Delete this section. The MPC533 implements only one TouCAN module whose signals are not shared.
Chapter 18, Global	Remove all references to PPM short functionality.
18.3.1, 18-4	Replace Figure 18-2, “Block Diagram of the PPM Module” with the following:

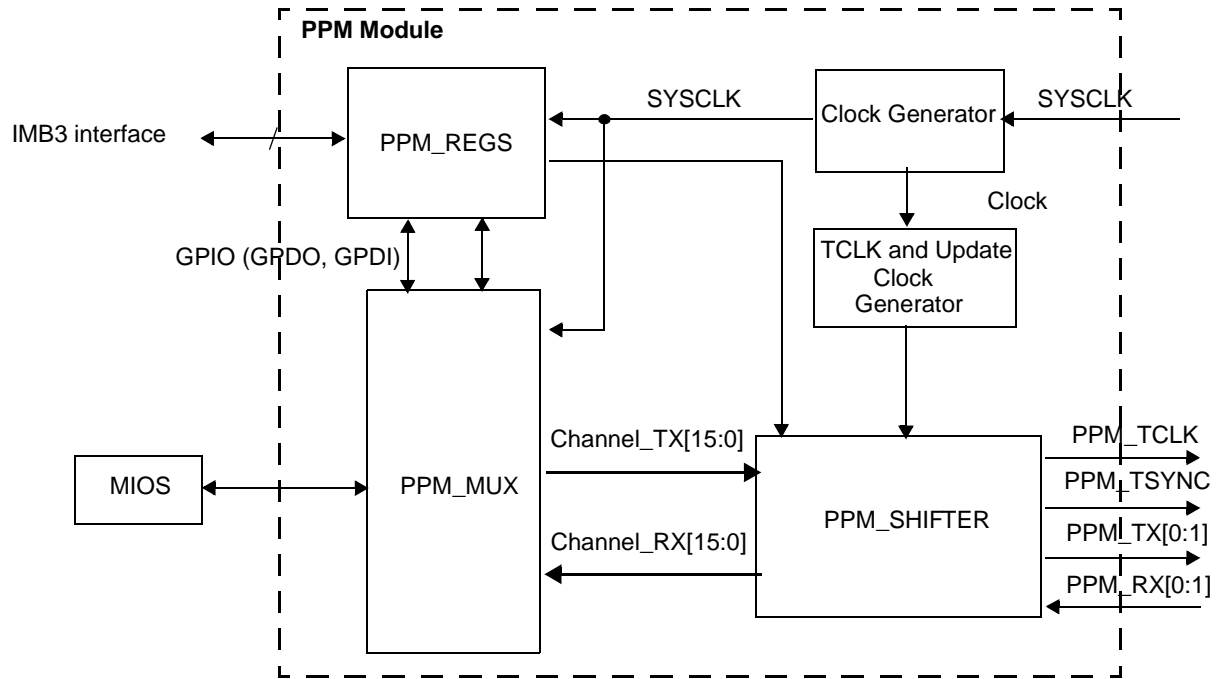

- 18.3.2, 18-9 Delete this section, including sub-sections. The MPC533 does not implement the PPM short functionality.
- 18.4.10, 18-18 Delete this section. The MPC533 does not implement the PPM short functionality.
- 18.4.11, 18-19 Delete this section. The MPC533 does not implement the PPM short functionality.
- Appendix H, Global Delete the following:  
 Table H-8. DLCMD2 (Data Link Controller Module)  
 All references to QSMCM B (Queued Serial Multi-Channel Module)  
 All references to CALRAM\_B
- Appendix K, K-75 In Figure K-63, delete C\_CNRX0 and C\_CNTX0 from pins K23 and K24. TouCAN module C is not implemented on the MPC533.

**HOW TO REACH US:****USA / EUROPE / Locations Not Listed:**

Motorola Literature Distribution  
P.O. Box 5405  
Denver, Colorado 80217  
1-800-521-6274 or 480-768-2130

**JAPAN:**

Motorola Japan Ltd.  
SPS, Technical Information Center  
3-20-1, Minami-Azabu Minato-ku  
Tokyo, 106-8573 Japan  
81-3-3440-3569

**ASIA/PACIFIC:**

Motorola Semiconductors H.K. Ltd.  
Silicon Harbour Centre  
2 Dai King Street  
Tai Po Industrial Estate  
Tai Po, N.T., Hong Kong  
852-26668334

**HOME PAGE:**

<http://motorola.com/semiconductors>



Information in this document is provided solely to enable system and software implementers to use Motorola products. There are no express or implied copyright licenses granted hereunder to design or fabricate any integrated circuits or integrated circuits based on the information in this document.

Motorola reserves the right to make changes without further notice to any products herein. Motorola makes no warranty, representation or guarantee regarding the suitability of its products for any particular purpose, nor does Motorola assume any liability arising out of the application or use of any product or circuit, and specifically disclaims any and all liability, including without limitation consequential or incidental damages. "Typical" parameters which may be provided in Motorola data sheets and/or specifications can and do vary in different applications and actual performance may vary over time. All operating parameters, including "Typicals" must be validated for each customer application by customer's technical experts. Motorola does not convey any license under its patent rights nor the rights of others. Motorola products are not designed, intended, or authorized for use as components in systems intended for surgical implant into the body, or other applications intended to support or sustain life, or for any other application in which the failure of the Motorola product could create a situation where personal injury or death may occur. Should Buyer purchase or use Motorola products for any such unintended or unauthorized application, Buyer shall indemnify and hold Motorola and its officers, employees, subsidiaries, affiliates, and distributors harmless against all claims, costs, damages, and expenses, and reasonable attorney fees arising out of, directly or indirectly, any claim of personal injury or death associated with such unintended or unauthorized use, even if such claim alleges that Motorola was negligent regarding the design or manufacture of the part.

MOTOROLA and the Stylized M Logo are registered in the U.S. Patent and Trademark Office. All other product or service names are the property of their respective owners. Motorola, Inc. is an Equal Opportunity/Affirmative Action Employer.

© Motorola, Inc. 2003

MPC533RMAD/D, Rev. 0, 9/2003

**For More Information On This Product,  
Go to: [www.freescale.com](http://www.freescale.com)**