

Technical Supplement

MC68C812A4 3.3V Electrical Characteristics

The MC68C812A4 is the low-voltage version of the standard MC68HC812A4 microcontroller unit (MCU), a 16-bit device composed of standard on-chip peripheral modules connected by an intermodule bus. Modules include a 16-bit central processing unit (CPU12), a Lite integration module (LIM), two asynchronous serial communications interfaces (SCI0 and SCI1), a serial peripheral interface (SPI), a timer and pulse accumulation module, an 8-bit analog-to-digital converter (ATD), 1-Kbyte RAM, 4-Kbyte EEPROM, and memory expansion logic with chip selects, key wakeup ports, and a phase-locked loop (PLL).

This supplement contains the most accurate electrical information for the MC68C812A4 microcontroller available at the time of publication. The information should be considered preliminary and is subject to change. The following characteristics are contained in this document:

Table 1 Maximum Ratings

Table 2 Thermal Characteristics

Table 3 DC Electrical Characteristics

Table 4 Supply Current

Table 5 ATD Maximum Ratings

Table 6 ATD DC Electrical Characteristics

Table 7 Analog Converter Characteristics (Operating)

Table 8 ATD AC Characteristics (Operating)

Table 9 EEPROM Characteristics

Table 10 Control Timing

Table 11 Peripheral Port Timing

Table 12 Non-Multiplexed Expansion Bus Timing

Table 13 SPI Timing



Table 1 Maximum Ratings¹

Rating	Symbol	Value	Unit
Supply voltage	V_{DD}, V_{DDA}, V_{DDX}	-0.3 to +6.5	V
Input voltage	V_{IN}	-0.3 to +6.5	V
Operating temperature range ² MC68C812A4PV5	T_A	T_L to T_H 0 to +70	°C
Storage temperature range	T_{stg}	-55 to +150	°C
Current drain per pin ³ Excluding V_{DD} and V_{SS}	I_{IN}	±25	mA
V_{DD} differential voltage	$V_{DD}-V_{DDX}$	6.5	V

NOTES:

1. Permanent damage can occur if maximum ratings are exceeded. Exposures to voltages or currents in excess of recommended values affects device reliability. Device modules may not operate normally while being exposed to electrical extremes.
2. Refer to MC68HC812A4TS/D Technical Summary for complete part numbers.
3. One pin at a time, observing maximum power dissipation limits. Internal circuitry protects the inputs against damage caused by high static voltages or electric fields; however, normal precautions are necessary to avoid application of any voltage higher than maximum-rated voltages to this high-impedance circuit. Extended operation at the maximum ratings can adversely affect device reliability. Tying unused inputs to an appropriate logic voltage level (either GND or V_{DD}) enhances reliability of operation.

Table 2 Thermal Characteristics

Characteristic	Symbol	Value	Unit
Average junction temperature	T_J	$T_A + (P_D \times \Theta_{JA})$	°C
Ambient temperature	T_A	User-determined	°C
Package thermal resistance (junction-to-ambient) 112-pin thin quad flat pack (TQFP)	Θ_{JA}	39	°C/W
Total power dissipation ¹	P_D	$\frac{P_{INT} + P_{I/O}}{K}$ $\bar{T}_J + 273^\circ\text{C}$	W
Device internal power dissipation	P_{INT}	$I_{DD} \times V_{DD}$	W
I/O pin power dissipation ²	$P_{I/O}$	User-determined	W
A constant ³	K	$P_D \times (T_A + 273^\circ\text{C}) + \Theta_{JA} \times P_D^2$	W · °C

NOTES:

1. This is an approximate value, neglecting $P_{I/O}$.
2. For most applications $P_{I/O} \ll P_{INT}$ and can be neglected.
3. K is a constant pertaining to the device. Solve for K with a known T_A and a measured P_D (at equilibrium). Use this value of K to solve for P_D and T_J iteratively for any value of T_A .

Table 3 DC Electrical Characteristics
 $V_{DD} = 3.3 \text{ Vdc} \pm 0.3\text{V}$, $V_{SS} = 0 \text{ Vdc}$, $T_A = T_L \text{ to } T_H$, unless otherwise noted

Characteristic	Symbol	Min	Max	Unit
Input high voltage, all inputs	V_{IH}	$0.7 \times V_{DD}$	$V_{DD} + 0.3$	V
Input low voltage, all inputs	V_{IL}	$V_{SS} - 0.3$	$0.2 \times V_{DD}$	V
Output high voltage All I/O and output pins Normal drive strength $I_{OH} = -10.0 \mu\text{A}$ $I_{OH} = -0.8 \text{ mA}$	V_{OH}	$V_{DD} - 0.2$	—	V
		$V_{DD} - 0.8$	—	V
Reduced drive strength $I_{OH} = -4.0 \mu\text{A}$ $I_{OH} = -0.3 \text{ mA}$		$V_{DD} - 0.2$	—	V
		$V_{DD} - 0.8$	—	V
Output low voltage, All I/O and output pins, normal drive strength $I_{OL} = 10.0 \mu\text{A}$ $I_{OL} = 1.6 \text{ mA}$	V_{OL}	—	$V_{SS} + 0.2$	V
		—	$V_{SS} + 0.4$	V
EXTAL, PAD[7:0], V_{RH} , V_{RL} , V_{FP} , \overline{XIRQ} , reduced drive strength $I_{OL} = 3.6 \mu\text{A}$ $I_{OL} = 0.6 \text{ mA}$		—	$V_{SS} + 0.2$	V
		—	$V_{SS} + 0.4$	V
Input leakage current ¹ all inputs except \overline{IRQ} , PAD7, and XFC $V_{in} = V_{DD}$ or V_{SS} \overline{IRQ} , PAD7, XFC	I_{in}	—	± 1	μA
		—	± 10	μA
Three-state leakage, I/O ports, BKGD, and \overline{RESET}	I_{OZ}	—	± 2.5	μA
Input capacitance All input pins and ATD pins (non-sampling) ATD pins (sampling) All I/O pins	C_{in}	—	10	pF
		—	15	pF
		—	20	pF
Output load capacitance All outputs except PS[7:4] PS[7:4]	C_L	—	90	pF
		—	130	pF
Active pull-up, pull-down current \overline{IRQ} , \overline{XIRQ} , ECLK, \overline{LSTRB} , R/W, BKGD, MODA, MODB, ARST Ports A, B, C, D, F, G, H, J, S, T	I_{APU}	50	500	μA
RAM standby voltage, power down	V_{SB}	2.0	—	V
RAM standby current	I_{SB}	—	1	mA

NOTES:

1. Specification is for parts in the 0 to +70°C range. Higher temperature ranges will result in increased current leakage.

Table 4 Supply Current
 $V_{DD} = 3.3 \text{ Vdc} \pm 0.3\text{V}$, $V_{SS} = 0 \text{ Vdc}$, $T_A = T_L$ to T_H , unless otherwise noted

Characteristic	Symbol	4 MHz	5 MHz	Unit	
Maximum total supply current	RUN:	Single-chip mode	15	17	mA
		Expanded mode	21	25	mA
	WAIT: (All peripheral functions shut down)	Single-chip mode	3	3.5	mA
		Expanded mode	3	3.5	mA
	STOP:				
	Single-chip mode, no clocks	S_{IDD}	250	250	μA
Maximum power dissipation ¹	Single-chip mode	54	62	mW	
	Expanded mode	76	90	mW	

NOTES:

 1. Includes I_{DD} and I_{DDA} .

 Note: I_{DD} is tested with a rail-to-rail square wave on EXTAL

Table 5 ATD Maximum Ratings

Characteristic	Symbol	Value	Units
ATD reference voltage	$V_{RH} \leq V_{DDA}$	-0.3 to +6.5	V
	$V_{RL} \geq V_{SSA}$	-0.3 to +6.5	V
V_{SS} differential voltage	$ V_{SS} - V_{SSA} $	0.1	V
V_{DD} differential voltage	$ V_{DD} - V_{DDA} $	6.5	V
	$V_{DD} - V_{DDX}$	6.5	V
V_{REF} differential voltage	$ V_{RH} - V_{RL} $	6.5	V
Reference to supply differential voltage	$ V_{RH} - V_{DDA} $	6.5	V
	$ V_{RL} - V_{SSA} $	6.5	V

Table 6 ATD DC Electrical Characteristics

$V_{DD} = 3.3 \text{ Vdc} \pm 0.3\text{V}$, $V_{SS} = 0 \text{ Vdc}$, $T_A = T_L$ to T_H , ATD Clock = 2 MHz, unless otherwise noted

Characteristic	Symbol	Min	Max	Unit
Analog supply voltage	V_{DDA}	3.0	3.6	V
Analog supply current Normal operation	I_{DDA}		1.0	mA
Reference voltage, low	V_{RL}	V_{SSA}	$V_{DDA}/2$	V
Reference voltage, high	V_{RH}	$V_{DDA}/2$	V_{DDA}	V
V_{REF} differential reference voltage ¹	$V_{RH}-V_{RL}$	3.0	3.6	V
Input voltage ²	V_{INDC}	V_{SSA}	V_{DDA}	V
Input current, off channel ³	I_{OFF}		100	nA
Reference supply current	I_{REF}		250	μA
Input capacitance	Not Sampling C_{INN} Sampling C_{INS}		10 15	pF pF

NOTES:

1. Accuracy is guaranteed at $V_{RH} - V_{RL} = 3.3 \text{ Vdc} \pm 0.3\text{V}$.
2. To obtain full-scale, full-range results, $V_{SSA} \leq V_{RL} \leq V_{INDC} \leq V_{RH} \leq V_{DDA}$.
3. Maximum leakage occurs at maximum operating temperature. Current decreases by approximately one-half for each 10°C decrease from maximum temperature.

Table 7 Analog Converter Characteristics (Operating)
 $V_{DD} = 3.3 \text{ Vdc} \pm 0.3\text{V}$, $V_{SS} = 0 \text{ Vdc}$, $T_A = T_L$ to T_H , ATD Clock = 2 MHz, unless otherwise noted

Characteristic	Symbol	Min	Typical	Max	Unit
8-bit resolution ¹	2 counts		24		mV
Differential non-linearity ²	DNL	-0.5		+0.5	count
Integral non-linearity ²	INL	-1		+1	count
Absolute error ^{2,3} 2, 4, 8, and 16 ATD sample clocks	AE	-2		+2	count
Maximum source impedance	R_S		20	See note ⁴	K Ω

NOTES:

- $V_{RH} - V_{RL} \geq 3.072\text{V}$
- At $V_{REF} = 3.072\text{V}$, one 8-bit count = 12 mV.
- Eight-bit absolute error of 2 counts (24 mV) includes 1/2 count (6 mV) inherent quantization error and 1 1/2 counts (18 mV) circuit (differential, integral, and offset) error.
- Maximum source impedance is application-dependent. Error resulting from pin leakage depends on junction leakage into the pin and on leakage due to charge-sharing with internal capacitance. Error from junction leakage is a function of external source impedance and input leakage current. Expected error in result value due to junction leakage is expressed in voltage (V_{ERRJ}):

$$V_{ERRJ} = R_S \times I_{OFF}$$

where I_{OFF} is a function of operating temperature. Charge-sharing effects with internal capacitors are a function of ATD clock speed, the number of channels being scanned, and source impedance. For 8-bit conversions, charge pump leakage is computed as follows:

$$V_{ERRJ} = .25\text{pF} \times V_{DDA} \times R_S \times \text{ATDCLK} / (8 \times \text{number of channels})$$

Table 8 ATD AC Characteristics (Operating)
 $V_{DD} = 3.3 \text{ Vdc} \pm 0.3\text{V}$, $V_{SS} = 0 \text{ Vdc}$, $T_A = T_L$ to T_H , ATD Clock = 2 MHz, unless otherwise noted

Characteristic	Symbol	Min	Max	Unit			
ATD operating clock frequency	f_{ATDCLK}	0.5	2.0	MHz			
Conversion time per channel $0.5 \text{ MHz} \leq f_{ATDCLK} \leq 2 \text{ MHz}$	t_{CONV}	9.0	32.0	μs			
18 ATD clocks					16.0	60.0	μs
32 ATD clocks							
Stop recovery time $V_{DDA} = 3.3\text{V}$	t_{SR}		50	μs			

Table 9 EEPROM Characteristics
 $V_{DD} = 3.3 \text{ Vdc} \pm 0.3\text{V}$, $V_{SS} = 0 \text{ Vdc}$, $T_A = T_L$ to T_H , unless otherwise noted

Characteristic	Symbol	Min	Typical	Max	Unit
Minimum programming clock frequency ¹	f_{PROG}	3.0			MHz
Programming time	t_{PROG}			20	ms
Clock recovery time following STOP, to continue programming	t_{CRSTOP}			$t_{\text{PROG}} + 1$	ms
Erase time	t_{ERASE}			20	ms
Write/erase endurance		10,000	30,000		cycles
Data retention		10			years

NOTES:

1. RC oscillator must be enabled if programming is desired and $f_{\text{SYS}} < f_{\text{PROG}}$.

Table 10 Control Timing

Characteristic	Symbol	5.0 MHz		Unit
		Min	Max	
Frequency of operation	f_o	dc	5.0	MHz
E-clock period	t_{cyc}	200	—	ns
Crystal frequency	f_{XTAL}	—	10.0	MHz
External oscillator frequency	$2f_o$	dc	10.0	MHz
Processor control setup time $t_{\text{PCSU}} = t_{\text{cyc}}/2 + 30$	t_{PCSU}	130	—	ns
Reset input pulse width To guarantee external reset vector Minimum input time (can be preempted by internal reset)	PW_{RSTL}	32 2	— —	t_{cyc} t_{cyc}
Mode programming setup time	t_{MPS}	4	—	t_{cyc}
Mode programming hold time	t_{MPH}	10	—	ns
Interrupt pulse width, $\overline{\text{IRQ}}$, edge-sensitive mode, KWU $PW_{\text{IRQ}} = 2t_{\text{cyc}} + 20$	PW_{IRQ}	420	—	ns
Wait recovery startup time	t_{WRS}	—	4	t_{cyc}
Timer pulse width, input capture pulse accumulator input $PW_{\text{TIM}} = 2t_{\text{cyc}} + 20$	PW_{TIM}	420	—	ns

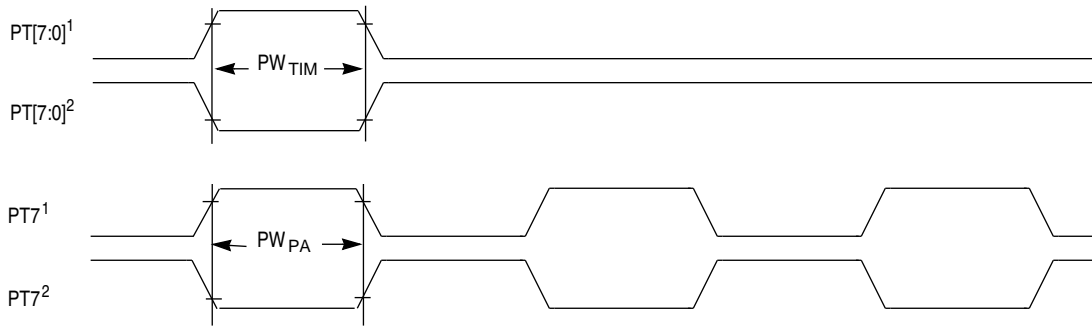

- NOTES :
1. Rising edge sensitive input
 2. Falling edge sensitive input

TIMER INPUT TIMING

Figure 1 Timer Inputs

Freescale Semiconductor, Inc.
PRELIMINARY

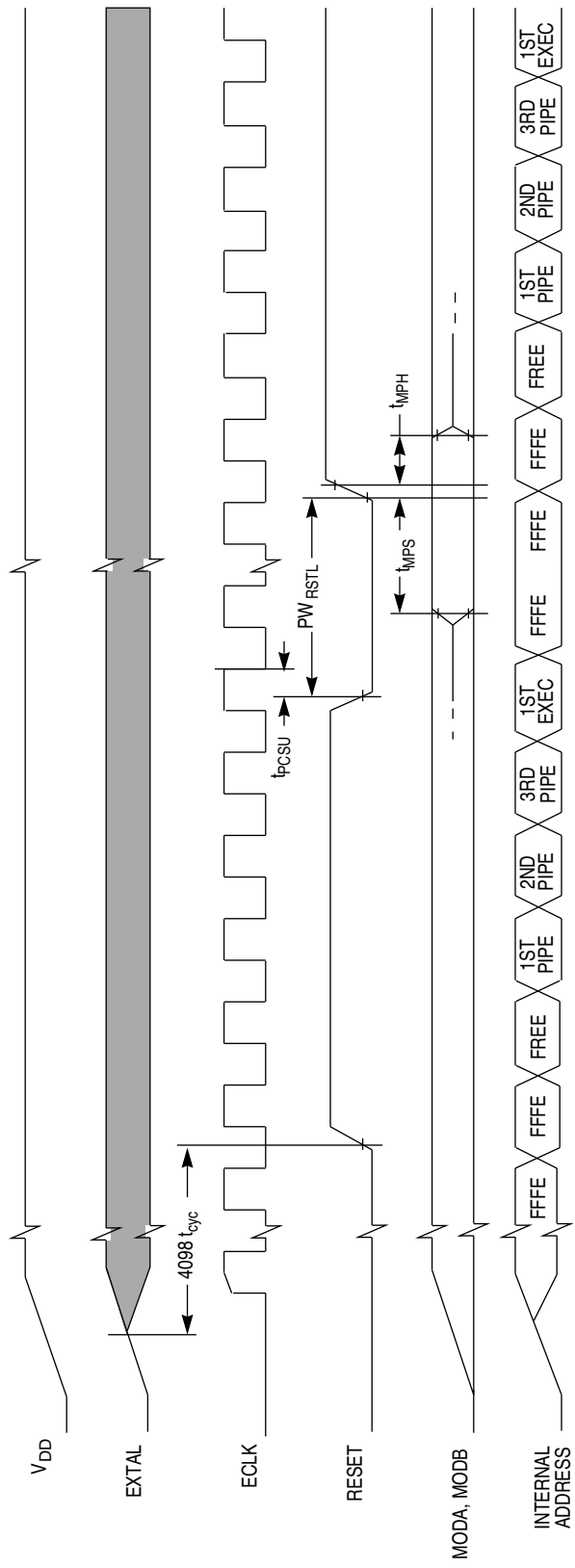

POR EXT RESET TIM

NOTE: Reset timing is subject to change.

Figure 2 POR and External Reset Timing Diagram

PRELIMINARY

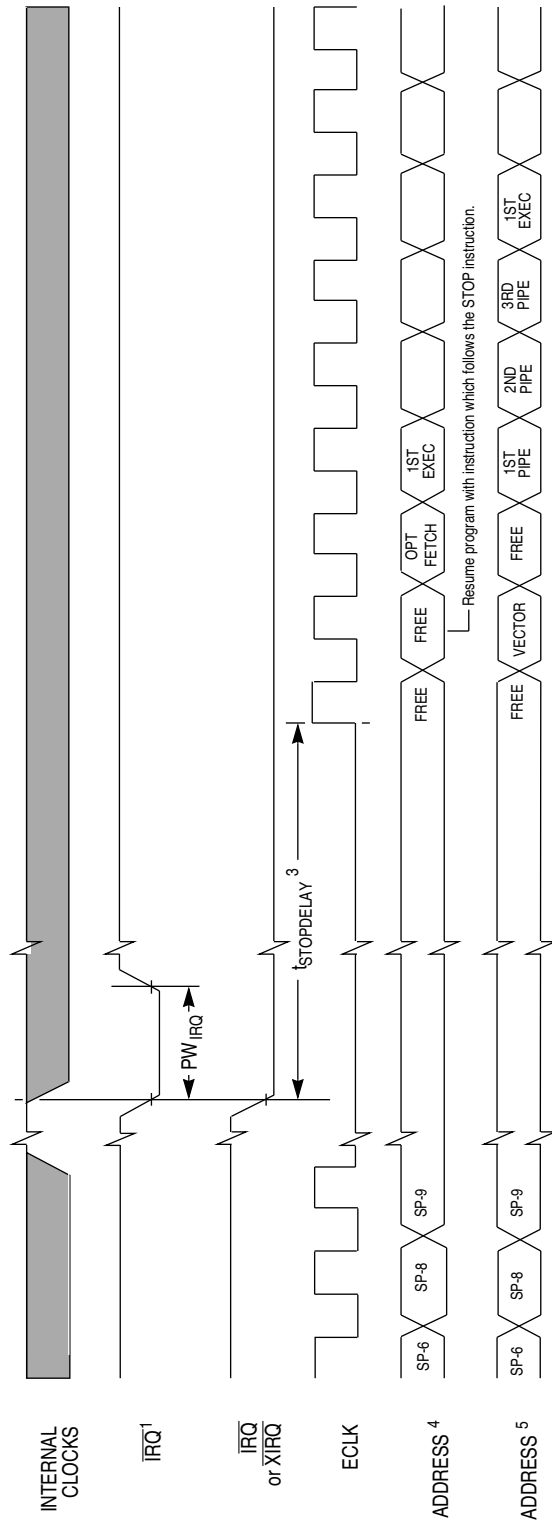

NOTES:

1. Edge Sensitive \overline{IRQ} pin (IRQE bit = 1)
2. Level sensitive \overline{IRQ} pin (IRQE bit = 0)
3. $t_{STOPDELAY} = 4098 t_{cyc}$ if DLY bit = 1 or $2 t_{cyc}$ if DLY = 0.
4. \overline{XIRQ} with X bit in CCR = 1.
5. \overline{IRQ} or \overline{XIRQ} with X bit in CCR = 0).

STOP RECOVERY TIM

Figure 3 STOP Recovery Timing Diagram

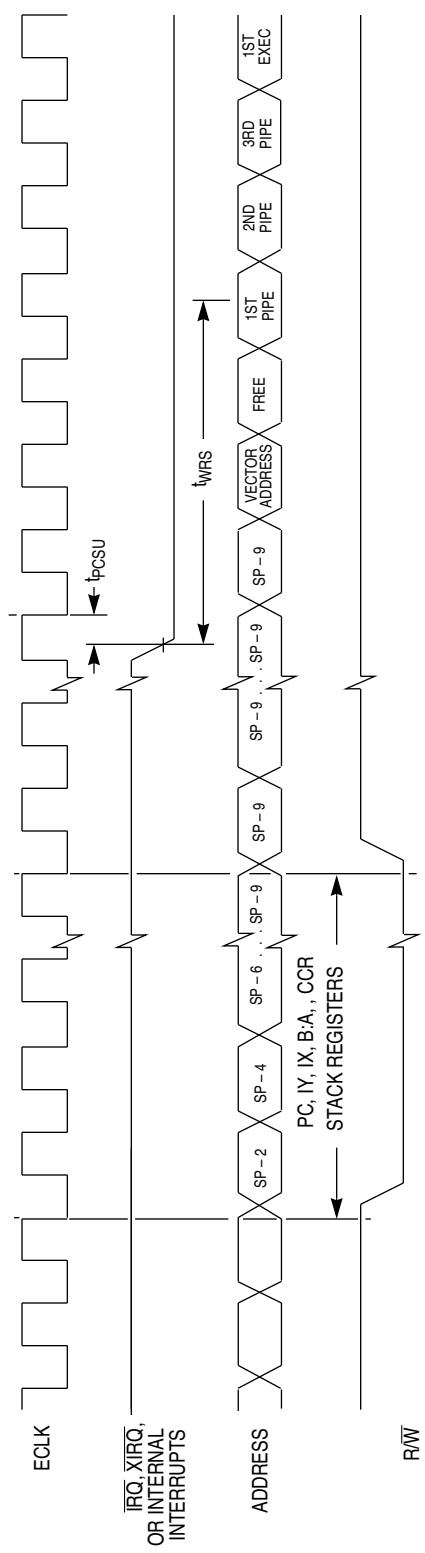

NOTE: RESET also causes recovery from WAIT.

WAIT RECOVERY TIM

Figure 4 WAIT Recovery Timing Diagram

PRELIMINARY

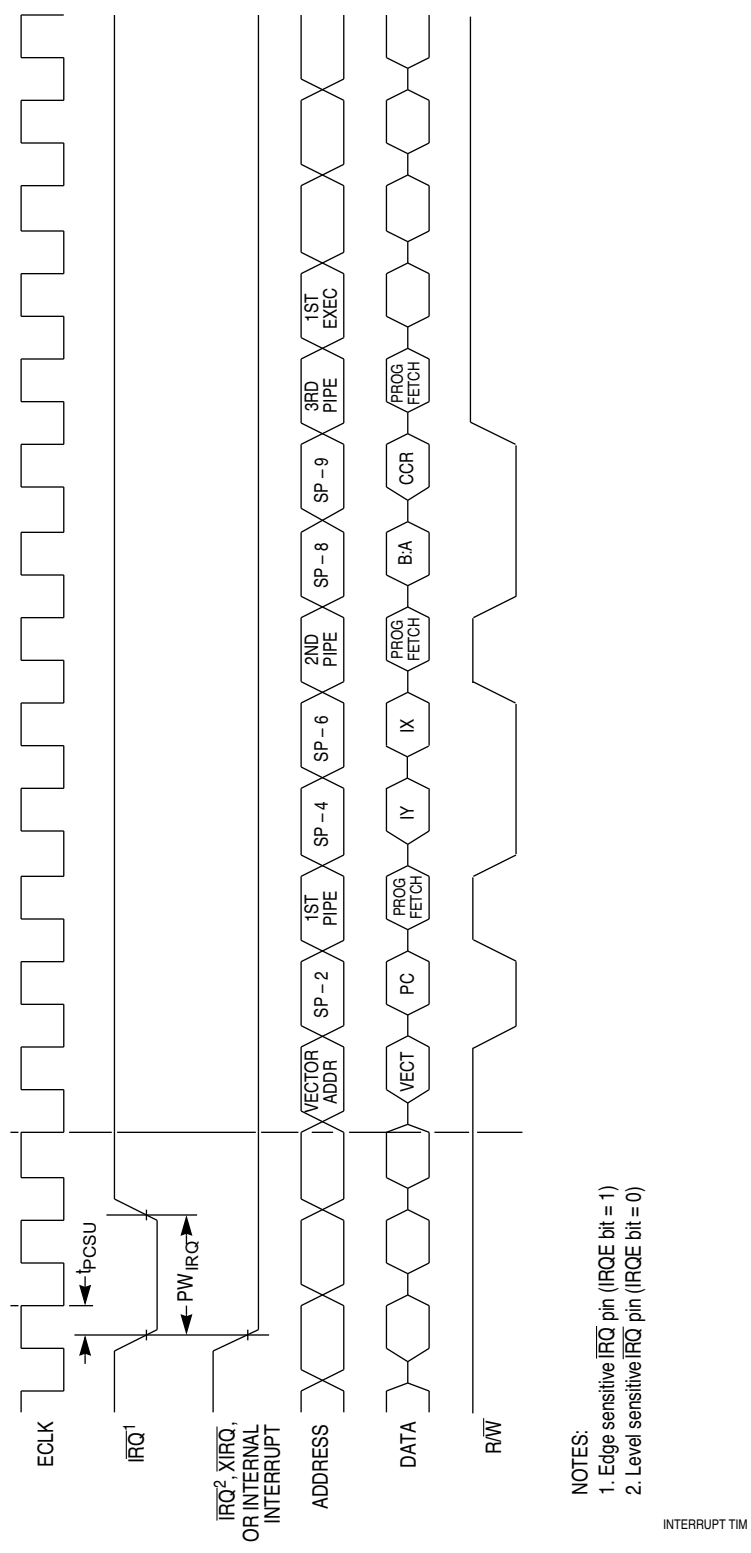

Figure 5 Interrupt Timing Diagram

Table 11 Peripheral Port Timing

Characteristic	Symbol	5.0 MHz		Unit
		Min	Max	
Frequency of operation (E-clock frequency)	f_o	dc	5.0	MHz
E-clock period	t_{cyc}	200	—	ns
Peripheral data setup time MCU read of ports $t_{PDSU} = t_{cyc}/2 + 30$	t_{PDSU}	130	—	ns
Peripheral data hold time MCU read of ports	t_{PDH}	0	—	ns
Delay time, peripheral data write MCU write to ports	t_{PWD}	—	40	ns

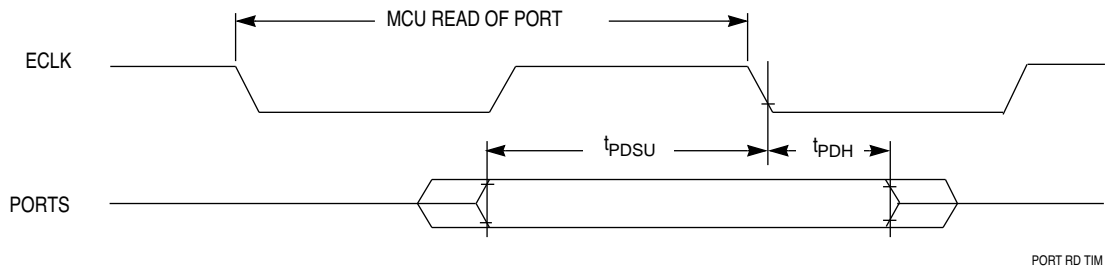

Figure 6 Port Read Timing Diagram

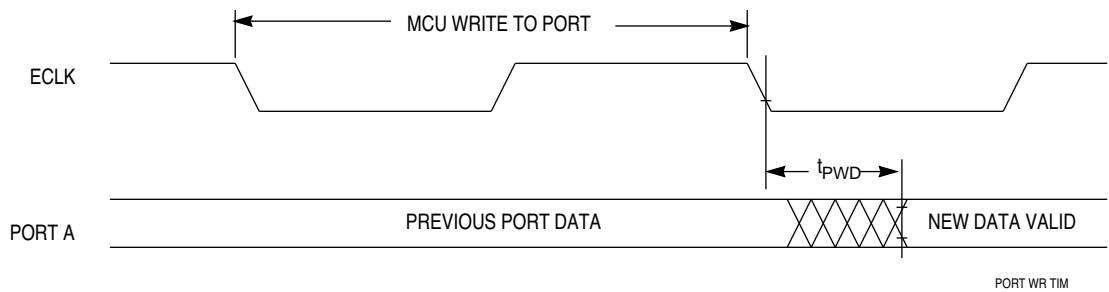

Figure 7 Port Write Timing Diagram

Table 12 Non-Multiplexed Expansion Bus Timing
 $V_{DD} = 3.3 \text{ Vdc} \pm 0.3\text{V}$, $V_{SS} = 0 \text{ Vdc}$, $T_A = T_L$ to T_H , unless otherwise noted

Num	Characteristic ¹	Delay	Symbol	5 MHz		Unit
				Min	Max	
	Frequency of operation (E-clock frequency)		f_o	dc	5.0	MHz
1	Cycle time $t_{cyc} = 1/f_o$		t_{cyc}	200	—	ns
2	Pulse width, E low $PW_{EL} = t_{cyc}/2 + \text{delay}$	-2	PW_{EL}	98	—	ns
3	Pulse width, E high ² $PW_{EH} = t_{cyc}/2 + \text{delay}$	-2	PW_{EH}	98	—	ns
5	Address delay time $t_{AD} = t_{cyc}/4 + \text{delay}$	29	t_{AD}	—	79	ns
6	Address hold time	—	t_{AH}	20	—	ns
7	Address valid time to E rise $t_{AV} = PW_{EL} - t_{AD}$	—	t_{AV}	28	—	ns
11	Read data setup time	—	t_{DSR}	30	—	ns
12	Read data hold time	—	t_{DHR}	0	—	ns
13	Write data delay time $t_{DDW} = t_{cyc}/4 + \text{delay}$	25	t_{DDW}	—	75	ns
14	Write data hold time	—	t_{DHW}	20	—	ns
15	Write data setup time ² $t_{DSW} = PW_{EH} - t_{DDW}$	—	t_{DSW}	23	—	ns
16	Read/write delay time $t_{RWD} = t_{cyc}/4 + \text{delay}$	20	t_{RWD}	—	70	ns
17	Read/write valid time to E rise $t_{RWV} = PW_{EL} - t_{RWD}$	—	t_{RWV}	28	—	ns
18	Read/write hold time	—	t_{RWH}	20	—	ns
19	Low strobe delay time $t_{LSD} = t_{cyc}/4 + \text{delay}$	20	t_{LSD}	—	70	ns
20	Low strobe valid time to E rise $t_{LSV} = PW_{EL} - t_{LSD}$	—	t_{LSV}	28	—	ns
21	Low strobe hold time	—	t_{LSH}	20	—	ns
22	Address access time ² $t_{ACCA} = t_{cyc} - t_{AD} - t_{DSR}$	—	t_{ACCA}	—	100	ns
23	Access time from E rise ² $t_{ACCE} = PW_{EH} - t_{DSR}$	—	t_{ACCE}	—	68	ns
26	Chip select delay time $t_{CSD} = t_{cyc}/4 + \text{delay}$	29	t_{CSD}	—	79	ns
27	Chip select access time ² $t_{ACCS} = t_{cyc} - t_{CSD} - t_{DSR}$	—	t_{ACCS}	—	100	ns
28	Chip select hold time	—	t_{CSH}	0	10	ns
29	Chip select negated time $t_{CSN} = t_{cyc}/4 + \text{delay}$	5	t_{CSN}	55	—	ns

NOTES:

1. All timings are calculated for normal port drives.
2. This characteristic is affected by clock stretch.
Add $N \times t_{cyc}$ where $N = 0, 1, 2, \text{ or } 3$, depending on the number of clock stretches.

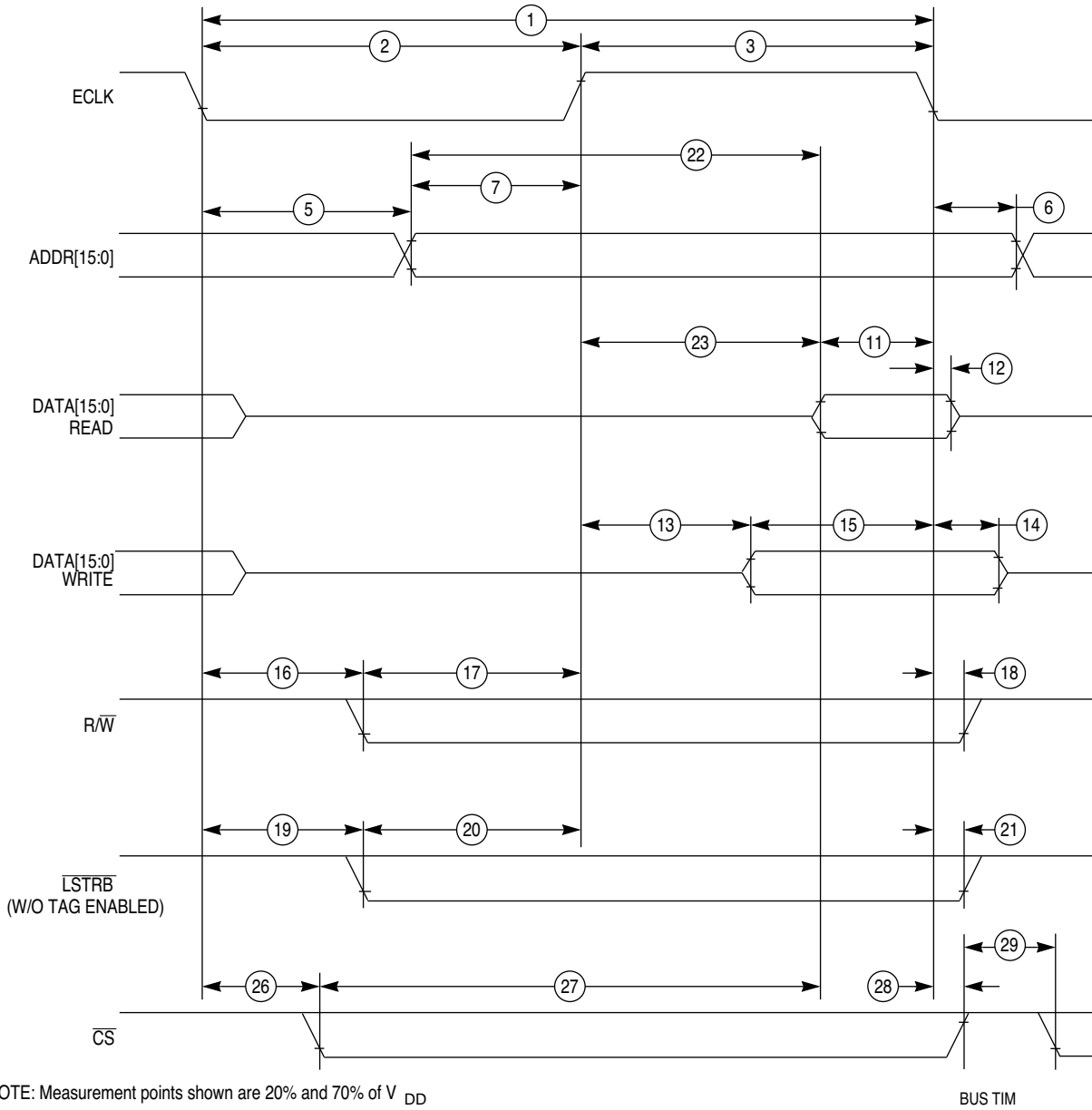

Figure 8 Non-Multiplexed Expansion Bus Timing Diagram

Table 13 SPI Timing
 $V_{DD} = 3.3 \text{ Vdc} \pm 0.3\text{V}$, $V_{SS} = 0 \text{ Vdc}$, $T_A = T_L \text{ to } T_H$, 130 pF load on all SPI pins¹

Num	Function	Symbol	Min	Max	Unit
	Operating Frequency Master Slave	f_{op}	DC DC	1/2 1/2	E-clock frequency
1	SCK Period Master Slave	t_{sck}	2 2	256 —	t_{cyc} t_{cyc}
2	Enable Lead Time Master Slave	t_{lead}	1/2 1	— —	t_{sck} t_{cyc}
3	Enable Lag Time Master Slave	t_{lag}	1/2 1	— —	t_{sck} t_{cyc}
4	Clock (SCK) High or Low Time Master Slave	t_{wsck}	$t_{cyc} - 60$ $t_{cyc} - 30$	$128 t_{cyc}$ —	ns ns
5	Sequential Transfer Delay Master Slave	t_{td}	1/2 1	— —	t_{sck} t_{cyc}
6	Data Setup Time (Inputs) Master Slave	t_{su}	30 30	— —	ns ns
7	Data Hold Time (Inputs) Master Slave	t_{hi}	0 30	— —	ns ns
8	Slave Access Time	t_a	—	1	t_{cyc}
9	Slave MISO Disable Time	t_{dis}	—	1	t_{cyc}
10	Data Valid (after SCK Edge) Master Slave	t_v	— —	50 50	ns ns
11	Data Hold Time (Outputs) Master Slave	t_{ho}	0 0	— —	ns ns
12	Rise Time Input Output	t_{ri} t_{ro}	— —	$t_{cyc} - 30$ 30	ns ns
13	Fall Time Input Output	t_{fi} t_{fo}	— —	$t_{cyc} - 30$ 30	ns ns

NOTES:

 1. All AC timing is shown with respect to 20% V_{DD} and 70% V_{DD} levels unless otherwise noted.

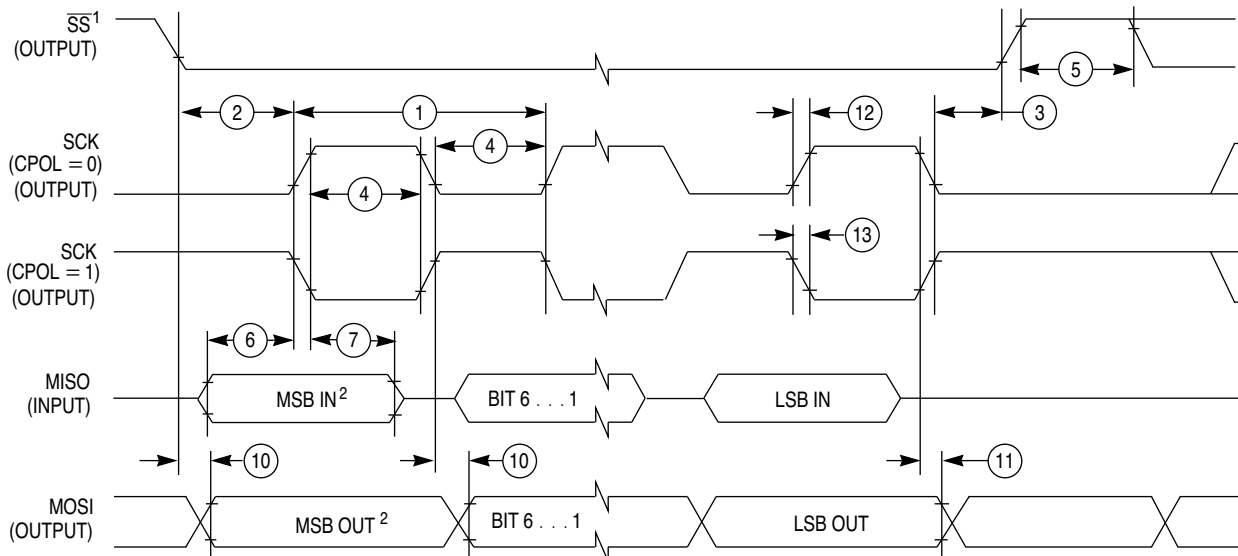

- 1. \overline{SS} output mode (DDS7 = 1, SSOE = 1).
- 2. LSBF = 0. For LSBF = 1, bit order is LSB, bit 1, ..., bit 6, MSB.

SPI MASTER CPHA0

A) SPI Master Timing (CPHA = 0)

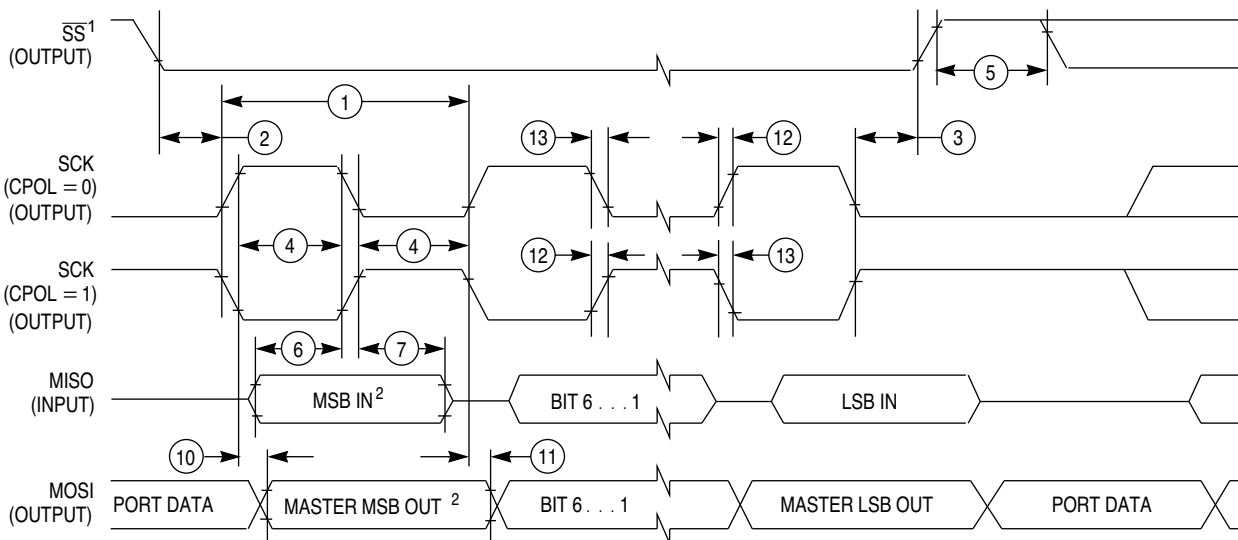

- 1. \overline{SS} output mode (DDS7 = 1, SSOE = 1).
- 2. LSBF = 0. For LSBF = 1, bit order is LSB, bit 1, ..., bit 6, MSB.

SPI MASTER CPHA1

B) SPI Master Timing (CPHA = 1)

Figure 9 SPI Timing Diagram (1 of 2)

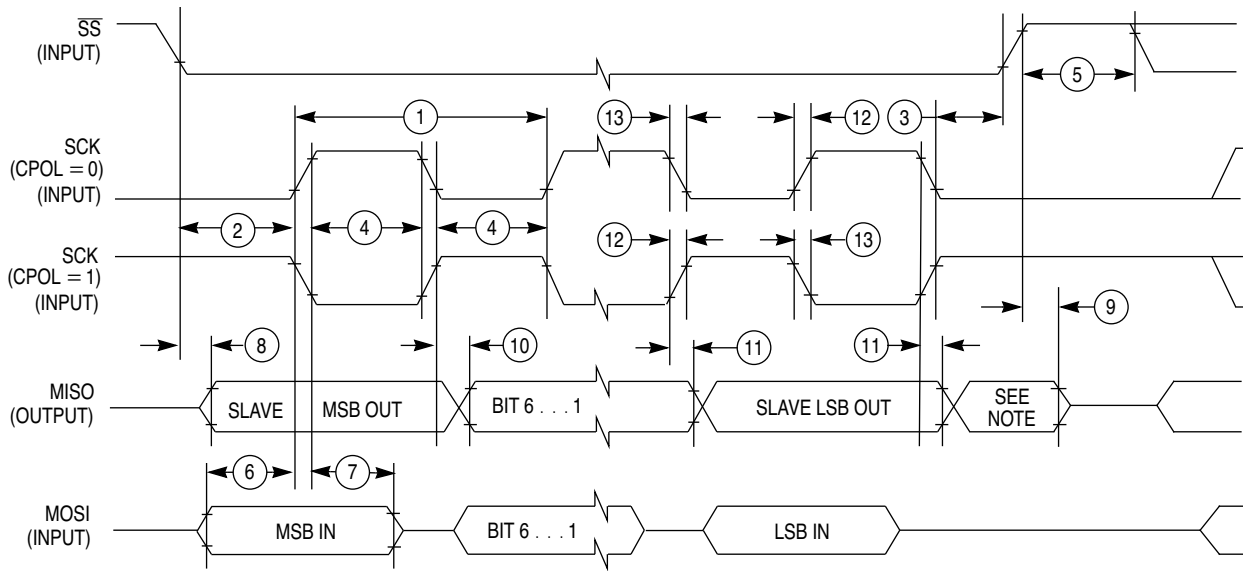

NOTE: Not defined but normally MSB of character just received.

SPI SLAVE CPHA0

A) SPI Slave Timing (CPHA = 0)

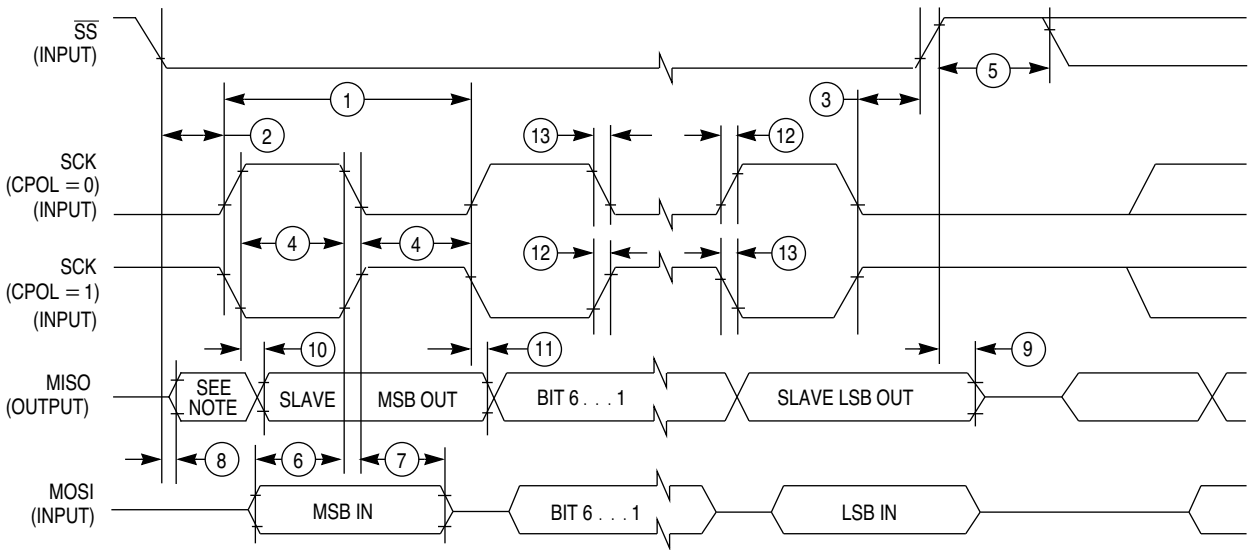

NOTE: Not defined but normally LSB of character just received.

SPI SLAVE CPHA1

B) SPI Slave Timing (CPHA = 1)

Figure 10 SPI Timing Diagram (2 of 2)

Information in this document is provided solely to enable system and software implementers to use Freescale Semiconductor products. There are no express or implied copyright licenses granted hereunder to design or fabricate any integrated circuits or integrated circuits based on the information in this document. Freescale Semiconductor reserves the right to make changes without further notice to any products herein. Freescale Semiconductor makes no warranty, representation or guarantee regarding the suitability of its products for any particular purpose, nor does Freescale Semiconductor assume any liability arising out of the application or use of any product or circuit, and specifically disclaims any and all liability, including without limitation consequential or incidental damages. "Typical" parameters which may be provided in Freescale Semiconductor data sheets and/or specifications can and do vary in different applications and actual performance may vary over time. All operating parameters, including "Typicals" must be validated for each customer application by customer's technical experts. Freescale Semiconductor does not convey any license under its patent rights nor the rights of others. Freescale Semiconductor products are not designed, intended, or authorized for use as components in systems intended for surgical implant into the body, or other applications intended to support or sustain life, or for any other application in which the failure of the Freescale Semiconductor product could create a situation where personal injury or death may occur. Should Buyer purchase or use Freescale Semiconductor products for any such unintended or unauthorized application, Buyer shall indemnify and hold Freescale Semiconductor and its officers, employees, subsidiaries, affiliates, and distributors harmless against all claims, costs, damages, and expenses, and reasonable attorney fees arising out of, directly or indirectly, any claim of personal injury or death associated with such unintended or unauthorized use, even if such claim alleges that Freescale Semiconductor was negligent regarding the design or manufacture of the part.

RoHS-compliant and/or Pb-free versions of Freescale products have the functionality and electrical characteristics of their non-RoHS-compliant and/or non-Pb-free counterparts. For further information, see <http://www.freescale.com> or contact your Freescale sales representative.

For information on Freescale's Environmental Products program, go to <http://www.freescale.com/epp>.

