

AN14956

Reliable ON/OFF Functionality for i.MX 94 and i.MX 95 Families

Rev. 1.0 — 6 May 2026

Application note

Document information

Information	Content
Keywords	AN14956, i.MX 94 and i.MX 95 family, ERR052780, ONOFF pin, emergency shutdown
Abstract	This application note describes the workaround for the erratum ERR052780 affecting the i.MX 94 and i.MX 95 chips.



1 Introduction

This application note describes the workaround for the erratum ERR052780 affecting the i.MX 94 and i.MX 95 chips.

2 Erratum summary

A pending Time Alarm Event (TA = 0b10) in the BBNSM_EVENTS register disables the power off function. The ONOFF pin does not power off the system when held low longer than the Button Press Timeout (BTN_TIMEOUT in the BBNSM_CTRL register). This rule applies in both smart Power Management IC (PMIC) mode and dumb PMIC mode.

If the system is in a software state where it no longer acknowledges or processes the Time Alarm Event, the ONOFF pin does not work as expected. The system does not power off when the ONOFF pin stays low for a long time.

To ensure a reliable ON/OFF functionality regardless of the software state and bugs, the following workaround is proposed.

3 Workaround description and implementation

The workaround uses an external reset timer IC to trigger a delayed system reset from the same signal connected to the ONOFF pin. This guarantees the SoC reset regardless of any internal state.

In this case, holding the ONOFF pin low for different durations triggers different behaviors:

- Brief pull to GND: Triggers a software interrupt to handle system suspend/resume actions.
- 5-second pull to GND: Triggers the system shutdown when (1) there is no RTC alarm enabled, or (2) if the RTC alarm is enabled, but not pending.
- 7.5 sec pull to GND (timer IC dependent): The external timer IC triggers the system reset regardless of the system state. After the system reset, due to the EMG_OFF bit (in the BBNSM_CTRL register) being set, the system shuts down. Briefly pulling the ONOFF pin to GND restarts the system.

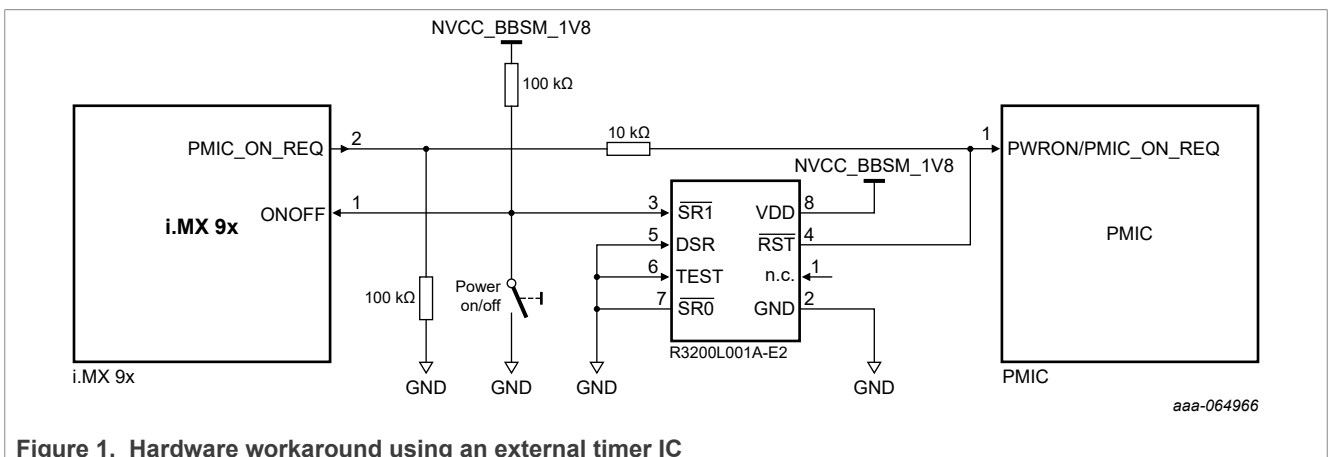

Note: For [Figure 1](#), i.MX 9x represent i.MX 94 and i.MX 95 family processors

4 Revision history

[Table 1](#) summarizes the revisions to this document.

Table 1. Revision history

Document ID	Release date	Description
AN14956 v.1.0	6 May 2026	Initial public release

Legal information

Definitions

Draft — A draft status on a document indicates that the content is still under internal review and subject to formal approval, which may result in modifications or additions. NXP Semiconductors does not give any representations or warranties as to the accuracy or completeness of information included in a draft version of a document and shall have no liability for the consequences of use of such information.

Disclaimers

Limited warranty and liability — Information in this document is believed to be accurate and reliable. However, NXP Semiconductors does not give any representations or warranties, expressed or implied, as to the accuracy or completeness of such information and shall have no liability for the consequences of use of such information. NXP Semiconductors takes no responsibility for the content in this document if provided by an information source outside of NXP Semiconductors.

In no event shall NXP Semiconductors be liable for any indirect, incidental, punitive, special or consequential damages (including - without limitation - lost profits, lost savings, business interruption, costs related to the removal or replacement of any products or rework charges) whether or not such damages are based on tort (including negligence), warranty, breach of contract or any other legal theory.

Notwithstanding any damages that customer might incur for any reason whatsoever, NXP Semiconductors' aggregate and cumulative liability towards customer for the products described herein shall be limited in accordance with the Terms and conditions of commercial sale of NXP Semiconductors.

Right to make changes — NXP Semiconductors reserves the right to make changes to information published in this document, including without limitation specifications and product descriptions, at any time and without notice. This document supersedes and replaces all information supplied prior to the publication hereof.

Suitability for use — NXP Semiconductors products are not designed, authorized or warranted to be suitable for use in life support, life-critical or safety-critical systems or equipment, nor in applications where failure or malfunction of an NXP Semiconductors product can reasonably be expected to result in personal injury, death or severe property or environmental damage. NXP Semiconductors and its suppliers accept no liability for inclusion and/or use of NXP Semiconductors products in such equipment or applications and therefore such inclusion and/or use is at the customer's own risk.

Applications — Applications that are described herein for any of these products are for illustrative purposes only. NXP Semiconductors makes no representation or warranty that such applications will be suitable for the specified use without further testing or modification.

Customers are responsible for the design and operation of their applications and products using NXP Semiconductors products, and NXP Semiconductors accepts no liability for any assistance with applications or customer product design. It is customer's sole responsibility to determine whether the NXP Semiconductors product is suitable and fit for the customer's applications and products planned, as well as for the planned application and use of customer's third party customer(s). Customers should provide appropriate design and operating safeguards to minimize the risks associated with their applications and products.

NXP Semiconductors does not accept any liability related to any default, damage, costs or problem which is based on any weakness or default in the customer's applications or products, or the application or use by customer's third party customer(s). Customer is responsible for doing all necessary testing for the customer's applications and products using NXP Semiconductors products in order to avoid a default of the applications and the products or of the application or use by customer's third party customer(s). NXP does not accept any liability in this respect.

Terms and conditions of commercial sale — NXP Semiconductors products are sold subject to the general terms and conditions of commercial sale, as published at <https://www.nxp.com/profile/terms>, unless otherwise agreed in a valid written individual agreement. In case an individual agreement is concluded only the terms and conditions of the respective agreement shall apply. NXP Semiconductors hereby expressly objects to applying the customer's general terms and conditions with regard to the purchase of NXP Semiconductors products by customer.

Export control — This document as well as the item(s) described herein may be subject to export control regulations. Export might require a prior authorization from competent authorities.

Suitability for use in non-automotive qualified products — Unless this document expressly states that this specific NXP Semiconductors product is automotive qualified, the product is not suitable for automotive use. It is neither qualified nor tested in accordance with automotive testing or application requirements. NXP Semiconductors accepts no liability for inclusion and/or use of non-automotive qualified products in automotive equipment or applications.

In the event that customer uses the product for design-in and use in automotive applications to automotive specifications and standards, customer (a) shall use the product without NXP Semiconductors' warranty of the product for such automotive applications, use and specifications, and (b) whenever customer uses the product for automotive applications beyond NXP Semiconductors' specifications such use shall be solely at customer's own risk, and (c) customer fully indemnifies NXP Semiconductors for any liability, damages or failed product claims resulting from customer design and use of the product for automotive applications beyond NXP Semiconductors' standard warranty and NXP Semiconductors' product specifications.

HTML publications — An HTML version, if available, of this document is provided as a courtesy. Definitive information is contained in the applicable document in PDF format. If there is a discrepancy between the HTML document and the PDF document, the PDF document has priority.

Translations — A non-English (translated) version of a document, including the legal information in that document, is for reference only. The English version shall prevail in case of any discrepancy between the translated and English versions.

Security — Customer understands that all NXP products may be subject to unidentified vulnerabilities or may support established security standards or specifications with known limitations. Customer is responsible for the design and operation of its applications and products throughout their lifecycles to reduce the effect of these vulnerabilities on customer's applications and products. Customer's responsibility also extends to other open and/or proprietary technologies supported by NXP products for use in customer's applications. NXP accepts no liability for any vulnerability. Customer should regularly check security updates from NXP and follow up appropriately. Customer shall select products with security features that best meet rules, regulations, and standards of the intended application and make the ultimate design decisions regarding its products and is solely responsible for compliance with all legal, regulatory, and security related requirements concerning its products, regardless of any information or support that may be provided by NXP.

NXP has a Product Security Incident Response Team (PSIRT) (reachable at PSIRT@nxp.com) that manages the investigation, reporting, and solution release to security vulnerabilities of NXP products.

NXP B.V. — NXP B.V. is not an operating company and it does not distribute or sell products.

Trademarks

Notice: All referenced brands, product names, service names, and trademarks are the property of their respective owners.

NXP — wordmark and logo are trademarks of NXP B.V.

Contents

1	Introduction	2
2	Erratum summary	2
3	Workaround description and implementation	2
4	Revision history	2
	Legal information	4

Please be aware that important notices concerning this document and the product(s) described herein, have been included in section 'Legal information'.

© 2026 NXP B.V.

For more information, please visit: <https://www.nxp.com>

All rights reserved.

[Document feedback](#)

Date of release: 6 May 2026
Document identifier: AN14956