



# SPI控制的12V外部工业照明开关

## MC12XSC

Last Updated: Apr 8, 2022

恩智浦MC12XSC eXtreme开关器件是SPI控制的智能高边开关，适用于工业应用，无需复杂的软件便可提供诊断，及全面的故障管理和负载控制功能。

- 该器件采用可编程多段闭锁过流关断保护，在过载情况下，可最大程度地减少器件内部的热压力，大大降低结温上升，并大幅提高可靠性。
- 该系列产品采用SOICW-EP封装
- 低导通电阻和大规模集成特性可降低模块大小、功耗和系统总成本。

## Dual Output Simplified Application Drawing Block Diagram

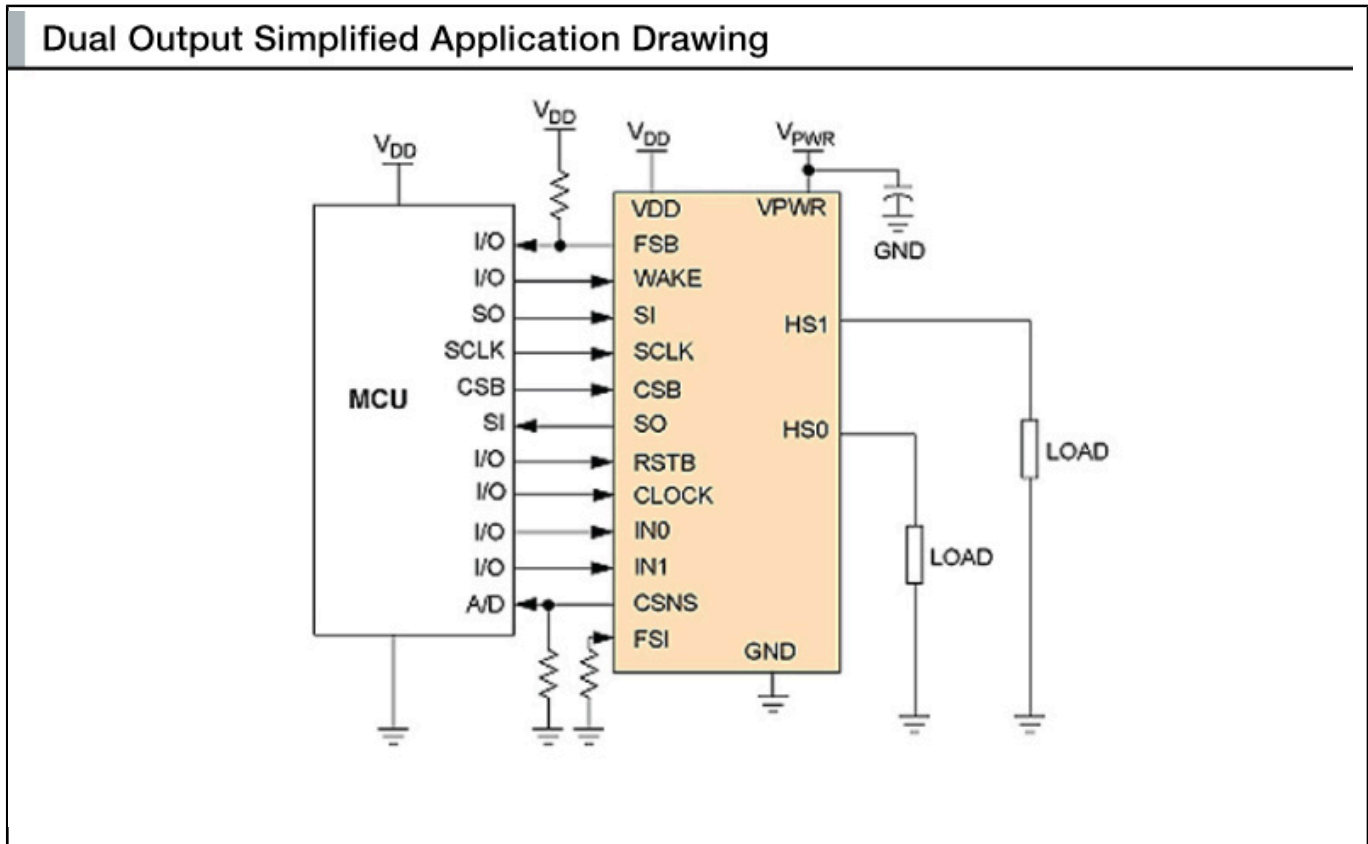

View additional information for [SPI控制的12V外部工业照明开关](#).

**Note:** The information on this document is subject to change without notice.

[www.nxp.com](http://www.nxp.com)

NXP and the NXP logo are trademarks of NXP B.V. All other product or service names are the property of their respective owners. The related technology may be protected by any or all of patents, copyrights, designs and trade secrets. All rights reserved. © 2023 NXP B.V.